

COMMUNICATIONS SITE LEASE

between

**CITY AND COUNTY OF SAN FRANCISCO,
as Landlord**

and

**T-MOBILE WEST LLC,
as Tenant**

For the lease of

**a Site at 1 South Van Ness Avenue
San Francisco, California**

February 28, 2017

TABLE OF CONTENTS

	<u>Page</u>
1. BASIC LEASE INFORMATION	1
2. CO-LOCATION OF TELECOMMUNICATIONS FACILITIES	3
2.1 Prohibition on Co-location Without Landlord's Consent	3
2.2 Required Co-location	3
3. PREMISES; AS IS LEASE	4
3.1 Lease Premises	4
3.2 As Is Lease	4
4. TERM	4
4.1 Term of Lease	4
4.2 Confirmation of Commencement Date and Expiration Date	5
4.3 Delay in Lease Commencement	5
5. RENT; ADDITIONAL CHARGES	5
5.1 Base Rent	5
5.2 Adjustments in Base Rent	5
5.3 Additional Charges	5
5.4 Late Charges	6
5.5 Default Interest	6
6. USE	6
6.1 Permitted Use	6
6.2 No Illegal Uses or Nuisances	6
7. INSTALLATION OF TENANT IMPROVEMENTS	6
7.1 Tenant Improvement Work	6
7.2 Air-conditioning and Fire Suppression	7
8. ALTERATIONS	7
8.1 Tenant's Alterations	7
8.2 Title to and Removal of Tenant's Equipment	8
8.3 Taxes on Tenant's Property	8
8.4 Local Hiring Requirements for Improvements and Alterations	8
8.5 Wages and Working Conditions	9
9. CITY'S ALTERATIONS OF THE BUILDING AND BUILDING SYSTEMS	9
10. REPAIRS AND MAINTENANCE	9

10.1	City's Repairs	9
10.2	Tenant's Repairs.....	10
11.	LIENS	10
12.	UTILITIES AND SERVICES	11
12.1	Utilities and Services	11
12.2	Mandatory or Voluntary Restrictions	11
12.3	Floor Load.....	11
13.	COMPLIANCE WITH LAWS AND RISK MANAGEMENT REQUIREMENTS	12
13.1	Compliance with Laws	12
13.2	Licenses and Approvals	12
13.3	Radiofrequency Radiation and Electromagnetic Fields.....	13
13.4	Compliance with City's Risk Management Requirements	13
14.	SUBORDINATION.....	13
15.	DAMAGE OR DESTRUCTION.....	13
16.	EMINENT DOMAIN	14
16.1	Eminent Domain	14
16.2	Temporary Takings.....	15
17.	ASSIGNMENT AND SUBLETTING	15
17.1	Restriction on Assignment and Subletting.....	15
17.2	Notice of Proposed Transfer	15
17.3	City's Response	15
17.4	Effect of Sublease or Assignment.....	16
17.5	Assumption by Transferee	16
17.6	Permitted Assignment.....	16
18.	DEFAULT	16
18.1	Events of Default	16
18.2	Remedies.....	17
19.	TENANT'S INDEMNITY	18
20.	INSURANCE.....	18
20.1	Tenant's Insurance.....	18
20.2	Tenant's Property	20
20.3	City's Self Insurance	20
20.4	Waiver of Subrogation.....	20
21.	LIMITATION OF CITY'S LIABILITY	20

21.1	Limitation on City's Liability.....	20
21.2	Consequential Damages.....	20
21.3	No Relocation Assistance	21
22.	ACCESS TO PREMISES	21
22.1	Tenant's Access to the Premises	21
22.2	City's Access to the Premises.....	22
22.3	Emergency Access	22
22.4	No Liability	22
22.5	No Abatement	22
22.6	Minimize Disruption.....	23
23.	ESTOPPEL CERTIFICATES	23
24.	RULES AND REGULATIONS	23
25.	SECURITY DEPOSIT.....	23
26.	SURRENDER OF PREMISES.....	24
27.	HAZARDOUS MATERIALS.....	24
27.1	Definitions.....	24
27.2	Hazardous Materials in Premises.....	25
27.3	Tenant's Environmental Indemnity	25
28.	SPECIAL PROVISIONS.....	25
28.1	Extension Options.....	25
28.2	Tenant's Right to Terminate.....	26
28.3	City's Right to Terminate Due to Finding by Board of Supervisors.....	26
28.4	City's Protection Against Interference	26
28.5	Tenant's Protection Against Interference	26
29.	GENERAL PROVISIONS	27
29.1	Notices	27
29.2	No Implied Waiver	27
29.3	Amendments	28
29.4	Authority	28
29.5	Interpretation of Lease	28
29.6	Successors and Assigns.....	28
29.7	Brokers.....	28
29.8	Severability	29
29.9	Governing Law	29

29.10	Entire Agreement	29
29.11	Attorneys' Fee	29
29.12	Holding Over	30
29.13	Time of Essence	30
29.14	Cumulative Remedies	30
29.15	Survival of Indemnities.....	30
29.16	Signs.....	30
29.17	Light and Air.....	30
29.18	Recording	30
29.19	Taxes, Assessments, Licenses, Permit Fees and Liens.....	31
29.20	Non-Liability of City Officials, Employees and Agents	31
29.21	Non-Discrimination in City Contracts and Benefits Ordinance	31
29.22	Requiring Health Benefits for Covered Employees.....	32
29.23	MacBride Principles - Northern Ireland	34
29.24	Drug-Free Workplace	34
29.25	Tropical Hardwood and Virgin Redwood Ban	34
29.26	Pesticide Prohibition	34
29.27	Prohibition of Tobacco Sales and Advertising	34
29.28	Prohibition of Alcoholic Beverage Advertising	35
29.29	Preservative-Treated Wood Containing Arsenic	35
29.30	Conflicts of Interest.....	35
29.31	Notification of Limitations on Contributions	35
29.32	Sunshine Ordinance	36
29.33	Sugar-Sweetened Beverage Prohibition	36
29.34	Counterparts.....	36
29.35	Effective Date	37
29.36	Cooperative Drafting	37

LIST OF EXHIBITS

- EXHIBIT A – Description of Premises
- EXHIBIT B – Notice of Commencement Date
- EXHIBIT C – Approved Tenant's Plans and Specifications
- EXHIBIT D – Conditional Use Permit

COMMUNICATIONS SITE LEASE

THIS COMMUNICATIONS SITE LEASE (this "Lease") dated for reference purposes only as of February 28, 2017, is made between the CITY AND COUNTY OF SAN FRANCISCO, a municipal corporation ("City" or "Landlord"), and T-MOBILE WEST LLC, a Delaware limited liability company ("Tenant").

City and Tenant hereby covenant and agree as follows:

1. BASIC LEASE INFORMATION

The following is a summary of basic lease information (the "Basic Lease Information"). Each item below shall be deemed to incorporate all of the terms set forth in this Lease pertaining to such item. In the event of any conflict between the information in this Section and any more specific provision of this Lease, the more specific provision shall control.

Lease Reference Date:	February 28, 2017
Landlord:	CITY AND COUNTY OF SAN FRANCISCO
Tenant:	T-MOBILE WEST LLC
Building (<u>Section 3.1</u>):	1 South Van Ness Avenue, San Francisco, California, 94103
Premises (<u>Section 3.1</u>):	The portions of the Building consisting of certain space located on the roof of the Building comprised of approximately two hundred (200) square feet of space on which nine (9) mobile/wireless antennas are to be mounted (as shown on <u>Exhibit A</u>). In connection with the lease of the Premises and for the term of the Lease, Tenant shall have a nonexclusive license for the placement and use of wiring and conduit as shown on the Approved Plans (as defined in <u>Section 7.1</u> below). The Building is under the jurisdiction of the City's Department of Real Estate.
Term (<u>Section 4.1</u>):	Estimated commencement date: June 1, 2017 Expiration date: May 31, 2027
Extension Options (<u>Section 28.1</u>):	Two (2) five-year options.
Initial Base Rent (<u>Section 5.1</u>):	Annual Base Rent: \$60,000.00 Monthly payments: \$5,000.00
Adjustment Dates (<u>Section 5.2</u>):	Each anniversary of the Commencement Date

Use (Section 6.1):

Tenant shall use the Premises for the transmission and reception of radio communication signals on various frequencies and the construction, maintenance and operation of related communications facilities as one of Tenant's communications sites (a "Communications Site"). Tenant shall not use the Premises for any other purposes without the written consent of Landlord.

Equipment (Section 7):

All equipment and improvements, if any, to be installed by Tenant at its sole cost, which shall consist of the following equipment and improvements (collectively, "Tenant's Equipment"): depicted in Exhibit C. Tenant may not modify Tenant's Equipment without City's prior written consent, which shall not be unreasonably withheld; provided, however, that Tenant may replace Tenant's Equipment with like-kind equipment after providing prior notice to City of such proposed replacement.

Utilities and Services (Section 12.1):

All utilities and services necessary for use of the Communications Site to be provided by Tenant at its sole cost; City has no responsibility for any utilities or services to the Premises or the common area unless (i) Tenant requires access to existing utilities for future equipment installations permitted under this Lease, in which case City agrees to provide such access, or (ii) City and Tenant determine that it is impractical for separate metering.

Security Deposit (Section 25):

Ten Thousand Dollars (\$10,000.00).

Notice Address of Landlord (Section 29.1):

Real Estate Division
City and County of San Francisco
25 Van Ness Avenue, Suite 400
San Francisco, CA 94102
Attn: John Updike
Director of Property
Re: T-Mobile Lease – 1SVN
Fax No.: (415) 552-9216

with a copy to:

Office of the City Attorney
City and County of San Francisco
City Hall, Room 234
1 Dr. Carlton B. Goodlett Place
San Francisco, CA 94102
Attn: Special Projects Team
Re: T-Mobile Lease – 1SVN
Fax No.: (415) 554-9807

Key Contact for Landlord: Gerald Sui, Facilities Manager

Telephone No.: (415) 554-4933

Notice Address for Tenant
(Section 29.1): T-Mobile USA, Inc.
12920 SE 38th Street
Bellevue, WA 98006
Attn: Lease Compliance
Site No. SF70359A

Key Contact for Tenant: T-Mobile Property Management

Telephone No.: (877) 373-0093

2. CO-LOCATION OF TELECOMMUNICATIONS FACILITIES

2.1 Prohibition on Co-location Without Landlord's Consent

Co-location of facilities is prohibited except with the express written approval of Landlord, which approval shall not be unreasonably withheld, delayed or conditioned. A "co-located telecommunication facility" means a telecommunication facility comprised of one or more antennas, dishes, or similar devices owned or used by more than one public or private entity that is not controlled by or under common control with Tenant. The meaning of "control" in the foregoing sentence shall be as set forth in Section 17.6.

2.2 Required Co-location

Notwithstanding the foregoing, Tenant is on notice that Landlord may require Tenant to co-locate its facilities on the Premises with other facilities or providers or require Tenant to permit other facilities or providers to co-locate on Tenant's facilities.

Tenant shall cooperate and use commercially reasonable efforts to facilitate co-location of future telecommunications facilities upon the premises; provided, however, that Tenant shall not be under any such obligation if a proposed co-location causes interference with Tenant's existing use of the Premises. If no such interference would occur upon installation of a co-locator's equipment as reasonably determined by Landlord, then the proposed co-locator in each instance shall, as a condition precedent to any proposed co-location: (i) execute and deliver a co-location agreement prepared in commercially reasonable form by the proposed co-locator; (ii) pay all costs arising from or related to the co-location, including but not limited to any and all costs incurred by Tenant to accommodate such co-location; and (iii) reimburse Tenant a commercially reasonable percentage of costs and expenses (including capital expenditures) incurred by Tenant in connection with the development, use, or occupancy of the Premises prior to the co-location.

3. PREMISES; AS IS LEASE

3.1 Lease Premises

Subject to the terms, covenants and conditions set forth in this Lease, City leases to Tenant and Tenant leases from City those premises specified in the Basic Lease Information and shown on the plans attached hereto as Exhibit A (the "Premises"). Tenant shall have access to the Premises and portions of the common areas of the Building as provided in Section 22.1 (Tenant's Access to Premises). In connection with its use of the Premises as a Communications Site and for the Term of this Lease, City grants Tenant a nonexclusive license for the placement and use of Tenant's equipment, utilities, and cabling across the areas shown on Exhibit C. Such license shall terminate upon any termination of this Lease. City, in its sole discretion, may relocate the license. As used herein, "Property" means the Premises, Building and real property upon which the Building is located and all other improvements and appurtenances to such land.

3.2 As Is Lease

TENANT EXPRESSLY ACKNOWLEDGES AND AGREES THAT THE PREMISES ARE BEING LEASED AND ACCEPTED IN THEIR "AS IS, WITH ALL FAULTS" CONDITION, WITHOUT REPRESENTATION OR WARRANTY OF ANY KIND, AND SUBJECT TO ALL APPLICABLE LAWS, RULES AND ORDINANCES, INCLUDING, WITHOUT LIMITATION, ZONING ORDINANCES AND REGULATIONS GOVERNING THE USE, OCCUPANCY OR POSSESSION OF THE PREMISES OR LICENSED AREAS. TENANT REPRESENTS AND WARRANTS TO LANDLORD THAT TENANT HAS CONDUCTED A REASONABLY DILIGENT INVESTIGATION, EITHER INDEPENDENTLY OR THROUGH AGENTS OF TENANT'S CHOOSING, OF THE CONDITION OF THE PREMISES AND OF THE SUITABILITY OF THE PREMISES FOR TENANT'S INTENDED USE, AND TENANT IS RELYING SOLELY ON ITS INDEPENDENT INVESTIGATION. TENANT FURTHER REPRESENTS AND WARRANTS THAT ITS INTENDED USE OF THE PREMISES IS THE USE DESCRIBED IN THE BASIC LEASE INFORMATION. TENANT AGREES THAT NEITHER CITY NOR ANY OF ITS AGENTS HAVE MADE, AND CITY DISCLAIMS, ANY REPRESENTATIONS OR WARRANTIES, EXPRESS OR IMPLIED, WITH RESPECT TO THE PHYSICAL, STRUCTURAL OR ENVIRONMENTAL CONDITION OF THE PREMISES OR THE PRESENT OR FUTURE SUITABILITY OF THE PREMISES OR LICENSED AREAS FOR THE CONDUCT OF TENANT'S BUSINESS, OR ANY OTHER MATTER WHATSOEVER RELATING TO THE PREMISES, INCLUDING, WITHOUT LIMITATION, ANY IMPLIED WARRANTIES OF MERCHANTABILITY OR FITNESS FOR A PARTICULAR PURPOSE. FOR PURPOSES OF CALIFORNIA CIVIL CODE SECTION 1938, TO THE EXTENT APPLICABLE TO THIS PERMIT, THE BUILDING HAS NOT BEEN INSPECTED BY A CERTIFIED ACCESS SPECIALIST.

4. TERM

4.1 Term of Lease

The Premises are leased for a term of ten (10) years (the "Initial Term"), commencing and terminating as set forth below. The Initial Term of this Lease shall end on the Expiration Date specified in the Basic Lease Information, or such earlier date on which this Lease terminates pursuant to the terms hereof. No delay in the commencement of this Lease beyond the Estimated Commencement Date specified in the Basic Lease Information shall serve to extend the Initial Term beyond the Expiration Date. Tenant shall have the right to extend the Initial Term for two (2) Extended Terms as provided in Section 28.1 (Options to Extend Term). As used below, the "Term" shall include the Initial Term and any of the Extended Terms if

Tenant duly exercises its Extension Options with respect to such Extended Term(s) pursuant to this Lease.

4.2 Confirmation of Commencement Date and Expiration Date

The Term of this Lease shall commence on City's Board of Supervisors and Mayor's approval and execution by the parties, and the earlier to occur of (i) the first day of the first month following Tenant's notice to Landlord in writing that Tenant has obtained all permits and approvals necessary for Tenant to be legally entitled to construct a facility for providing mobile/wireless communication services at the Premises, or (ii) the Estimated Commencement Date specified in the Basic Lease Information (the "Commencement Date"). The Term shall terminate on the Expiration Date unless earlier terminated pursuant to the terms hereof or extended as provided in Section 28.1. Promptly following the Commencement Date, if the Commencement Date occurs on a date other than the Estimated Commencement Date specified in the Basic Lease Information, Tenant shall deliver to City a notice in substantially the form attached hereto as Exhibit B identifying the Commencement Date determined in accordance with the provisions hereof, and City shall execute and return such notice to Tenant. However, the parties' failure to execute or deliver such notice shall not affect the commencement of the Term.

4.3 Delay in Lease Commencement

If Tenant does not obtain all necessary permits and approvals necessary for Tenant to be legally entitled to construct a facility for providing mobile/wireless communication services at the Premises within one hundred twenty (120) days from the Estimated Commencement Date, then either City or Tenant may terminate this Lease by written notice to the other party given within ten (10) days after such one hundred twenty (120)-day period, and neither party shall have any further rights or obligations hereunder.

5. RENT; ADDITIONAL CHARGES

5.1 Base Rent

Beginning on the Commencement Date, Tenant shall pay to City during the Term the annual Base Rent specified in the Basic Lease Information as the same may be increased pursuant to Section 5.2 (Adjustments in Base Rent) (the "Base Rent"). The Base Rent shall be payable in equal consecutive monthly payments on or before the first day of each month, in advance, by good check to the City and County of San Francisco at the address for the Director of Property specified in the Basic Lease Information, or such other place as City may designate in writing. Tenant shall pay the Base Rent without any prior demand and without any deduction or setoff. If the Commencement Date occurs on a day other than the first day of a calendar month, or the Expiration Date occurs on a day other than the last day of a calendar month, then the Base Rent for such fractional month shall be prorated based on a thirty (30)-day month.

5.2 Adjustments in Base Rent

On each date specified in the Basic Lease Information for the adjustment of Base Rent (an "Adjustment Date") during the Term, the Base Rent payable by Tenant under Section 5.1 (Base Rent) above shall be increased by three percent (3%) of the Base Rent payable for the immediately-preceding twelve (12) month period.

5.3 Additional Charges

Tenant shall promptly pay to City any and all Utility Charges under Section 12.1 (Utilities and Services), and other amounts, if any, required under any other provision of this Lease, as additional rent (herein called "Additional Charges"). Such Additional Charges shall be

payable to City at the same place and in the same manner as the Base Rent is payable. City shall have the same remedies for a default in the payment of any Additional Charges as for a default in the payment of Base Rent. As used in this Lease, the term "Rent" shall include the Base Rent and any Additional Charges.

5.4 Late Charges

If Tenant fails to pay any Rent within ten (10) days after delivery of notice that the same is due and payable, such unpaid amounts will be subject to a late payment charge equal to one hundred fifty percent (150%) of the unpaid amounts in each instance. The late payment charge has been agreed upon by City and Tenant, after negotiation, as a reasonable estimate of the additional administrative costs and detriment that will be incurred by City as a result of any such failure by Tenant, the actual costs thereof being extremely difficult if not impossible to determine. The late payment charge constitutes liquidated damages to compensate City for its damages resulting from such failure to pay and shall be paid to City together with such unpaid amounts.

5.5 Default Interest

Any Rent, if not paid within ten (10) days following the due date, shall bear interest from the due date until paid at the rate of six percent (6%) per year or, if a higher rate is legally permissible, at the highest rate an individual is permitted to charge under law. However, interest shall not be payable on late charges incurred by Tenant nor on any amounts on which late charges are paid by Tenant to the extent this interest would cause the total interest to be in excess of that which an individual is lawfully permitted to charge. Payment of interest and late charges shall not excuse or cure any default by Tenant.

6. USE

6.1 Permitted Use

Tenant shall use the Premises during the Term of this Lease solely for such uses as are specified in the Basic Lease Information and for no other use. Tenant shall not interfere with the use and operation of the Building.

6.2 No Illegal Uses or Nuisances

Without limiting the foregoing, Tenant shall not use or occupy any of the Premises, or permit the use or occupancy thereof, in any unlawful manner or for any illegal purpose, or permit to be carried on any offensive, immoral, noisy, or hazardous use. Tenant shall take all precautions to eliminate any nuisances or hazards in connection with its activities within the Premises. Tenant shall not advertise in any manner in areas outside the Premises or on or about the Building; provided, however that Tenant may place one identification plate on each piece of Tenant's equipment, which plate shall be no larger than nine inches (9") x nine inches (9") and shall be reasonably approved in advance by City, in order to identify Tenant's Equipment as belonging to Tenant.

7. INSTALLATION OF TENANT IMPROVEMENTS

7.1 Tenant Improvement Work

Following the Commencement Date, Tenant shall commence to install Tenant's Equipment and other improvements on the Premises in accordance with the plans and specifications dated August 24, 2016 prepared by Precision Design, Inc., Tenant's architect, which have been approved by City (such work is called the "Tenant Improvement Work" or

"Tenant Improvements" and such plans and specifications are called the "Approved Plans"). A copy of the Approved Plans is attached hereto as Exhibit C. The Approved Plans may be altered, subject to the prior written and reasonable approval of City, if required in order for Tenant to obtain any permits or approvals necessary for construction of the Tenant Improvements. Tenant shall be responsible, at its cost, for performing the Tenant Improvement Work in accordance with the Approved Plans and otherwise in compliance with the standards contained in Section 8.1 (Tenant's Alterations). Tenant shall further be responsible, at its cost, for obtaining all permits and licenses required in connection with the Tenant Improvements and satisfy any conditions or mitigation measures approved in connection therewith. No Tenant Improvement Work shall commence until Tenant has first obtained all necessary permits and approvals for Tenant to be legally entitled to construct the Tenant Improvements.

Tenant must obtain City's prior written approval under this Lease, which may be withheld or conditioned in City's sole discretion, to (i) modify the Tenant's Equipment in any way, and (ii) request City's Planning Department for any zoning, design and environmental approvals needed from City, in its regulatory capacity, for such proposed modifications ("Planning Department Approvals"). Tenant acknowledges that City's approval of any proposed modification requested by Tenant pursuant to this Lease may be conditioned on, among other requirements, changes to improve the design or reduce the impact of the proposed modifications to the surrounding environment, and shall be conditioned on written evidence that City's Planning Department has granted the Planning Department Approvals for such proposed modification.

Notwithstanding anything to the contrary in the foregoing paragraph, Tenant shall have the right to replace any of Tenant's Equipment with like-kind equipment after providing prior written notice to City of such proposed replacement. Any additional equipment that Tenant installs at the Premises with City's prior written approval, or any like-kind replacement equipment that Tenant installs at the Premises after providing prior written notice to City, at shall be deemed to be part of the Tenant's Equipment on installation.

7.2 Air-conditioning and Fire Suppression

Tenant shall have the right (but not the obligation) upon reasonable approval by City, to install and maintain at its own cost and expense a self-contained air-conditioning system and fire protection system on the Premises, as shown on the Approved Plans. Installation of such systems shall be in compliance with Section 7.1 (Tenant Improvement Work) and Section 8.1 (Tenant's Alterations).

8. ALTERATIONS

8.1 Tenant's Alterations

Tenant shall not make or permit any alterations ("Alterations") to the Building or any of the heating, ventilating, air conditioning, plumbing, electrical, fire protection, life safety, security and other mechanical, electrical, and communications systems of the Building (collectively, "Building Systems"), except with City's prior written consent in each instance which may be withheld in City's sole discretion. All Alterations shall be done at Tenant's sole expense in accordance with plans and specifications approved by City, only by duly licensed and bonded contractors or mechanics, and subject to all other conditions which City may reasonably impose. If the cost of any Alterations to the Building (excluding any shown on the Approved Plans) is in excess of Five Thousand Dollars (\$5,000), then Tenant shall pay City an administrative fee equal to ten percent (10%) of the total "hard" costs of the work. "Hard costs" shall include the cost of materials and installation, but shall exclude any costs associated with design, such as architectural fees.

8.2 Title to and Removal of Tenant's Equipment

Title to the Tenant's Equipment, Tenant Improvements, all permitted improvements or equipment installed at and affixed to the Premises by Tenant and all of Tenant's personal property (collectively, "Tenant's Property") shall remain the property of Tenant; provided, however, that any structural improvements to the Building made by Tenant shall become City's property and remain on the Premises. City hereby acknowledges that Tenant may grant to the vendor of the Tenant's Equipment to be installed at and affixed to the Premises a security interest in all equipment and fixtures owned by Tenant now or hereafter located at or on the Premises; provided no such security interest shall cover any portion of the Premises or the Building or City's property in, on or about the Building and further provided that any removal of such equipment or fixtures by the holder of any such security interest must be in compliance with the provisions of Section 26 (Surrender of Premises), and the holder of such security interest entering the Premises for such removal shall carry the insurance policies and amounts described in Section 20. Tenant may at any time, including any time it vacates the Premises (excluding the structural improvements referenced above), remove all of Tenant's Property from the Premises, subject to the provisions of Section 26 (Surrender of Premises). Notwithstanding anything to the contrary in this Lease, City can elect at any time prior to the Expiration Date or within thirty (30) days after termination of this Lease to require Tenant to remove on the Expiration Date or any earlier termination of this Lease in accordance with Section 26 (Surrender of Premises) at Tenant's sole expense, all or part of any structural improvements to the Premises or the common areas of the Building made by City or Tenant to provide sufficient support for Tenant's Equipment, including any antenna or tower supports, foundations, or base plates.

8.3 Taxes on Tenant's Property

At least ten (10) days prior to delinquency, Tenant shall pay all taxes levied or assessed upon Tenant's Property and shall deliver satisfactory evidence of such payment to City promptly upon request.

8.4 Local Hiring Requirements for Improvements and Alterations

Any undefined, initially-capitalized term used in this Section shall have the meaning given to such term in San Francisco Administrative Code Section 23.62 (the "Local Hiring Requirements"). Tenant Improvements and Alterations are subject to the Local Hiring Requirements unless the cost for such work is (i) estimated to be less than \$750,000 per building permit or (ii) meets any of the other exemptions in the Local Hiring Requirements. Tenant agrees that it shall comply with the Local Hiring Requirements to the extent applicable. Before starting any Tenant Improvement Work or any Alteration, Tenant shall contact City's Office of Economic Workforce and Development ("OEWD") to verify if the Local Hiring Requirements apply to the work (i.e., whether the work is a "Covered Project").

Tenant shall include, and shall require its subtenants to include, a requirement to comply with the Local Hiring Requirements in any contract for a Covered Project with specific reference to San Francisco Administrative Code Section 23.62. Each such contract shall name the City and County of San Francisco as a third party beneficiary for the limited purpose of enforcing the Local Hiring Requirements, including the right to file charges and seek penalties. Tenant shall cooperate, and require its subtenants to cooperate, with City in any action or proceeding against a contractor or subcontractor that fails to comply with the Local Hiring Requirements when required. Tenant's failure to comply with its obligations under this Section shall constitute a material breach of this Lease. A contractor's or subcontractor's failure to comply with this Section will enable City to seek the remedies specified in San Francisco Administrative Code Section 23.62 against the breaching party.

8.5 Wages and Working Conditions

Any undefined, initially-capitalized term used in this Section shall have the meaning given to such term in San Francisco Administrative Code Section 23.61. Tenant shall require its Contractors and Subcontractors performing (i) labor in connection with a "public work" as defined under California Labor Code Section 1720 *et seq.* (which includes certain construction, alteration, maintenance, demolition, installation, repair, carpet laying, or refuse hauling work if paid for in whole or part out of public funds) or (ii) Covered Construction, at the Premises to (1) pay workers performing such work not less than the Prevailing Rate of Wages, (2) provide the same hours, working conditions and benefits as in each case are provided for similar work performed in San Francisco County, and (3) employ Apprentices in accordance with San Francisco Administrative Code Section 23.61 (collectively, "Prevailing Wage Requirements"). Tenant agrees to cooperate with the City in any action or proceeding against a Contractor or Subcontractor that fails to comply with the Prevailing Wage Requirements.

Tenant shall include, and shall require its subtenants, and Contractors and Subcontractors (regardless of tier) to include, the Prevailing Wage Requirements and the agreement to cooperate in City enforcement actions in any Construction Contract with specific reference to San Francisco Administrative Code Section 23.61. Each such Construction Contract shall name the City and County of San Francisco, affected workers, and employee organizations formally representing affected workers as third party beneficiaries for the limited purpose of enforcing the Prevailing Wage Requirements, including the right to file charges and seek penalties against any Contractor or Subcontractor in accordance with San Francisco Administrative Code Section 23.61. Tenant's failure to comply with its obligations under this Section shall constitute a material breach of this Lease. A Contractor's or Subcontractor's failure to comply with this Section will enable the City to seek the remedies specified in San Francisco Administrative Code Section 23.61 against the breaching party. For the current Prevailing Rate of Wages, see www.sfgov.org/olse/prevailingwages or call the City's Office of Labor Standard Enforcement at 415-554-6235

9. CITY'S ALTERATIONS OF THE BUILDING AND BUILDING SYSTEMS

City reserves the right at any time to make alterations, additions, repairs, deletions or improvements to all or any part of the Building, the Building Systems or the common areas of the Building, for any purpose including compliance with mandatory or voluntary controls or guidelines, subject to the following terms and conditions. In performing any such work, City shall make good faith efforts to give Tenant prior notice of such work and shall make reasonable efforts not to disrupt Tenant's normal use of Tenant's Equipment in the Premises. The making of any such alterations, additions, repairs, deletions or improvements shall in no event entitle Tenant to any damages, relieve Tenant of the obligation to pay the full Base Rent and Additional Charges reserved hereunder or to perform each of its other covenants hereunder or constitute or be construed as a constructive or other eviction of Tenant, provided that Tenant can still operate the Premises as a Communications Site. During the period of any such alterations by City which materially impair Tenant's use of the Premises as a Communications Site, Tenant shall have the right, upon reasonable approval from City, at no additional charge to bring into the Building and operate a portable generator and mobile Communications Site and telescopic antennae or tower, in a mutually acceptable location and on the other terms and conditions provided with respect to such equipment in Section 14.1 (Damage and Destruction).

10. REPAIRS AND MAINTENANCE

10.1 City's Repairs

City shall not be responsible for any maintenance of any portion of the Building, except that City agrees (i) to correct any immediately life-threatening or hazardous condition that affects

any portion of the Building necessary for Tenant's use of the Premises as a Communications Site, so long as such condition is not the result of damage or destruction discussed in Section 15 (Destruction), the acts, omissions or negligence of Tenant or its Agents, such repair is not otherwise the responsibility of Tenant under Section 10.2 (Tenant's Repairs), and such condition is not disclosed to Tenant under any provision of this Lease or would not have otherwise been discovered by Tenant through a reasonably diligent inspection of the Premises prior to the reference date hereof, and (ii) to repair any condition caused by City or its tenants of the Building other than Tenant, which condition materially affects any portion of the Building necessary for Tenant's use of the Premises as a Communications Site and is not caused by damage or destruction discussed in Section 15 (Destruction). Upon becoming aware of any such condition, Tenant shall give the City written notice of the need for any repair for which the City is responsible under the preceding sentence; provided, however, that Tenant's agreement to provide written notice shall in no event be interpreted as an assumption of liability for such life-threatening or hazardous conditions unless Tenant would otherwise be responsible for such conditions hereunder. In the event that the costs of making the corrections or repairs described in Subsections (i) or (ii) above exceed Twenty-Five Thousand Dollars (\$25,000.00), City may elect to terminate this Lease within thirty (30) days of the condition requiring correction or repair in lieu of making such corrections or repairs, provided however, that Tenant may elect to pay the portion of such costs in excess of Twenty-Five Thousand Dollars (\$25,000.00) necessary in order to make such correction or repairs, in which case City will proceed with the correction or repair.

10.2 Tenant's Repairs

Tenant shall maintain all parts of its Premises at its sole expense, including without limitation, the floors, electrical wiring, fixtures and equipment, in good repair and working order and in a clean, safe and sanitary condition. Tenant shall repair all damage to the Building to the extent such damage results from any Tenant Alterations, Tenant's use of the Premises, or Tenant's entry on the Building pursuant to this Lease. Tenant shall make all repairs and replacements: (a) at Tenant's expense and at such time and, when required hereunder, in such manner as reasonably approved by City, (b) by duly licensed and bonded contractors or mechanics, (c) in a manner and using equipment and materials which will not interfere with or impair City's operations, use or occupation of the Building or the Building Systems, and (d) in accordance with any Building Rules and Regulations (as defined in Section 24 (Rules and Regulations)) and all applicable Laws (as defined in Section 13.1).

Tenant hereby waives any right it may have to make repairs at City's expense under Sections 1941 and 1942 of the California Civil Code (Lessor to make dwelling-house fit for its purpose, and Repairs by lessee, respectively) or under any similar law, statute or ordinance now or hereafter in effect.

11. LIENS

Tenant shall keep the Premises and the Building free from any liens arising out of any work performed, material furnished or obligations incurred by or for Tenant. In the event Tenant shall not, within thirty (30) days following the imposition of any such lien, cause the lien to be released of record by payment or posting of a proper bond, City shall have in addition to all other remedies provided herein and by law or equity the right, but not the obligation, to cause the same to be released by such means as it shall deem proper, including, but not limited to, payment of the claim giving rise to such lien. All such sums paid by City and all expenses incurred by it in connection therewith (including, without limitation, reasonable attorneys' fees) shall be payable to City by Tenant upon demand. City shall have the right at all times to post and keep posted on the Premises any notices permitted or required by law or that City shall deem proper for the protection of City, the Premises, and the Building, from mechanics' and material supplier's liens. Tenant shall give to City at least fifteen (15) days' prior written notice of commencement of any repair or construction on the Premises except for minor and routine repair and maintenance for

which Tenant is responsible hereunder. Tenant shall not create, permit or suffer any other encumbrances affecting any portion of the Premises or the Building except as expressly permitted under this Lease or without first obtaining the written consent of City, which City may give or withhold in its sole discretion.

12. UTILITIES AND SERVICES

12.1 Utilities and Services

Tenant shall furnish, at its cost, any and all utilities or services necessary or appropriate for Tenant's use and enjoyment of the Premises. Tenant shall install separate utility meters at the Premises and, when permitted by serving utilities, Tenant shall be responsible directly to the serving utilities for all utilities required for Tenant's use of the Premises. Tenant agrees to promptly pay for all such metered utilities. If the parties mutually determine it is impractical to have separate metering of Tenant's utilities at the Premises, Tenant shall pay City a monthly service charge (the "Monthly Utility Charge") of Three Hundred Dollars (\$300) for Tenant's use of the Building's utilities for the Tenant's Equipment. The Monthly Utility Charge shall be increased by three percent (3%) on each January 1 of the Term. Tenant shall not: (a) connect or use any electrical equipment that exceeds the capacity of the Building's electrical system; or (b) connect any apparatus, machine or device through electrical outlets, except in the manner for which such outlets are designed, or if such modifications are shown on the Approved Plans, and for any other such modifications at Tenant's sole cost as are reasonably approved in writing in advance by City.

12.2 Mandatory or Voluntary Restrictions

In the event City provides any utilities pursuant to Section 12.1 (Utilities and Services), and any governmental entity promulgates or revises any statute, ordinance or building, fire or other code or imposes mandatory or voluntary controls or guidelines on City or the Building or any part thereof, relating to the use or conservation of energy or electricity, or in the event City is required or elects to make alterations to any part of the Building in order to comply with such mandatory or voluntary controls or guidelines, such compliance and the making of such alterations shall in no event entitle Tenant to any damages, relieve Tenant of the obligation to pay the full Base Rent and Additional Charges reserved hereunder or to perform each of its other covenants hereunder or constitute or be construed as a constructive or other eviction of Tenant, provided that Tenant can still operate the Premises as a Communications Site.

12.3 Floor Load

Without the prior written consent of City, which City may give or refuse in City's sole discretion, Tenant shall not place or install in the Premises any machine, equipment, structure or other improvement the weight of which shall exceed the normal loadbearing capacity of the floors or roof of the Building, except as may be shown in the Approved Plans. If City consents to the placement or installation of any such machine or equipment in the Premises, Tenant at its sole expense shall reinforce the floor or roof of the Premises in the area of such placement or installation, pursuant to plans and specifications reasonably approved by City and otherwise in compliance with Section 8.1 (Tenant's Alterations), to the extent necessary to assure that no damage to the Premises or the Building or weakening of any structural supports will be occasioned thereby.

13. COMPLIANCE WITH LAWS AND RISK MANAGEMENT REQUIREMENTS

13.1 Compliance with Laws

Tenant, at Tenant's expense, shall promptly maintain the Premises, any Tenant Improvements and Tenant's Alterations and any other improvements and equipment permitted hereunder, and Tenant's use and operations thereon, in strict compliance with all present and future laws, orders and regulations of federal, state, county and municipal authorities (collectively, "Laws") relating to the Premises or the use or occupancy thereof, whether foreseen or unforeseen, ordinary as well as extraordinary. Such Laws shall include, without limitation, all Laws relating to health and safety and disabled accessibility including, without limitation, the Americans with Disabilities Act, 42 U.S.C. Section 12101 et seq. (insofar as such Act relates to Tenant's unique use) and Title 24 of the California Code of Regulations, all present and future Environmental Laws (as defined in Section 27.1 (Definitions)), and all present and future life safety, fire sprinkler, seismic retrofit and other building code requirements. Any work or installations made or performed by or on behalf of Tenant or any person or entity claiming through or under Tenant pursuant to the provisions of this Section shall be made in conformity with and subject to the provisions of Section 10.2 (Tenant's Repairs). In making any application to City's Planning Department for the Communications Site, Tenant agrees to act as both "Applicant" and "Project Sponsor." A copy of all conditional use permits authorizing use of the Premises are attached hereto as Exhibit D.

The parties acknowledge and agree that Tenant's obligation to comply with all Laws as provided herein is a material part of the bargained-for consideration under this Lease. Tenant's obligation under this Section shall include, without limitation, the responsibility of Tenant to make substantial or structural repairs and alterations to the Premises (including any of the Tenant Improvements or any of Tenant's Alterations), regardless of, among other factors, the relationship of the cost of curative action to the Rent under this Lease, the length of the then remaining Term hereof, the relative benefit of the repairs to Tenant or City, the degree to which the curative action may interfere with Tenant's use or enjoyment of the Premises, the likelihood that the parties contemplated the particular Law involved, and whether the Law involved is related to Tenant's particular use of the Premises. No occurrence or situation arising during the Term, nor any present or future Law, whether foreseen or unforeseen, and however extraordinary, shall relieve Tenant from its obligations hereunder, or shall give Tenant any right to terminate this Lease in whole or in part or to otherwise seek redress against City. Except as expressly provided herein, Tenant waives any rights now or hereafter conferred upon it by any existing or future Law to terminate this Lease, to receive any abatement, diminution, reduction or suspension of payment of Rent, or to compel City to make any repairs to comply with any such Laws, on account of any such occurrence or situation.

Tenant understands and agrees that City is entering into this Lease in its capacity as a property owner with a proprietary interest in the Premises and not as a regulatory agency with police powers. Nothing in this Lease shall limit in any way Tenant's obligation to obtain any required regulatory approvals from City departments, boards or commissions having jurisdiction over the Premises. By entering into this Lease, City is in no way modifying or limiting Tenant's obligation to cause the Premises to be used and occupied in accordance with all Laws as provided above.

13.2 Licenses and Approvals

Tenant represents and warrants that it has acquired all licenses, permits, and other approvals required under all federal, state, and local laws for the operation of Tenant's Equipment on the Premises. Tenant shall maintain all such licenses, permits or other approvals throughout the Term of this Lease.

13.3 Radiofrequency Radiation and Electromagnetic Fields

Without limiting Section 13.1 above, Tenant shall comply with all present and future laws, orders and regulations of federal, state, county and municipal authorities relating to allowable presence of or human exposure to Radiofrequency Radiation ("RFs") or Electromagnetic Fields ("EMFs") on or off the Premises, including without limitation, all applicable standards adopted by the Federal Communications Commission, whether such RF or EMF presence or exposure results from Tenant's Equipment alone or from the cumulative effect of Tenant's Equipment added to all other sources in the Building. City shall not agree to allow any third party entering into an occupancy or use agreement after the Commencement Date to cause an increase in RF or EMF levels in the Building such that the cumulative levels exceed allowable levels. If the cumulative effect of City's use of the Building taken together with Tenant's use hereunder and other tenant(s) whose use predated the Commencement Date exceeds such standards, Tenant shall have the right to terminate this Lease without penalty upon ninety (90) days' prior written notice to City. Without limiting the provisions of Tenant's indemnity contained in Section 19 (Indemnity), Tenant, on behalf of itself and its successors and assigns, shall indemnify the "Indemnified Parties" (as defined in Section 19 (Indemnity)), and each of them, from and against all "Claims" (as defined in Section 19 (Indemnity)), incurred in connection with or arising in whole or in part from the presence of or exposure to RFs or EMFs resulting from Tenant's use of the Premises.

13.4 Compliance with City's Risk Management Requirements

Tenant shall not do anything, or permit anything to be done, in or about the Premises which would create any unusual fire risk, and shall take commercially reasonable steps to protect City from any potential premises liability by reason of any business operation being conducted by Tenant in the Premises. Tenant, at Tenant's expense, shall comply with all reasonable rules, orders, regulations or requirements of City's Risk Manager.

14. SUBORDINATION

This Lease shall be subordinate to any reciprocal easement agreements, ground leases or underlying leases and the lien of any mortgage or deed of trust (collectively, "Encumbrance"), which may now exist or hereafter be executed affecting any of the Building, the real property upon which the Building is located or City's interest therein and all renewals, extensions, modifications, and replacements of such Encumbrance. Notwithstanding the foregoing, City shall have the right to subordinate any such Encumbrances to this Lease. If any ground lease or underlying lease terminates for any reason or any mortgage or deed of trust is foreclosed or a conveyance in lieu of foreclosure is made for any reason, Tenant shall attorn to the successor-in-interest to City, at the option of such successor-in-interest, provided that so long as Tenant is not in default hereunder, such successor-in-interest shall recognize this Lease and shall not disturb Tenant in its possession of the Premises for any reason other than one that would entitle City to terminate this Lease or otherwise dispossess Tenant of the Premises in accordance with the terms hereof. No further instrument shall be required to make the provisions hereof operative except that City shall give Tenant written notice of such subordination. Tenant agrees, however, to execute and deliver, upon demand by City and in the form requested by City, any additional documents evidencing the priority or subordination of this Lease provided such documents contain a non-disturbance and recognition agreement executed by the holder of such Encumbrance.

15. DAMAGE OR DESTRUCTION

The parties recognize that the Premises are a small portion of a building used as, among other things, a municipal office building. In the event of damage to the Premises or the Building by any cause, City shall have no obligation to rebuild or repair. If City, in City's sole and

absolute discretion, determines to repair or rebuild, City shall give Tenant written notice of its determination and its good faith estimate of the amount of time to repair or rebuild, within thirty (30) days of the date of such damage or destruction. If such repairs or rebuilding cannot be completed within two hundred ten (210) days after the date of such damage or destruction, or if City elects not to repair or rebuild as provided above, then Tenant shall have the right, at its election, to terminate this Lease upon sixty (60) days prior written notice to City.

During the period of any repair or rebuilding provided for hereunder, Tenant shall have the right, at its sole expense, to bring onto the Building in a location mutually acceptable to Tenant and City and to operate a portable generator and mobile Communications Site and telescopic antennae or tower in order to provide for continuous service to Tenant's customers during such period. Neither the placement nor use of such generator or equipment shall interfere with City's operations or business in the Building or, if City has elected to repair or rebuild the Premises or the Building as provided above, with such repair or reconstruction.

The parties hereto understand and agree that the provisions of this Section are intended to govern fully the rights and obligations of the parties in the event of damage or destruction, and Tenant and City each hereby waives and releases the provisions of Section 1932, subdivision 2, and Section 1933, subdivision 4, of the Civil Code of California (When hirer may terminate the hiring) or under any similar law, statute or ordinance now or hereafter in effect.

16. EMINENT DOMAIN

16.1 Eminent Domain

If all or any part of the Premises shall be taken as a result of the exercise of the power of eminent domain or any transfer in lieu thereof, this Lease shall terminate as to the part so taken as of the date of taking. In the case of a partial taking, Tenant shall have the right to terminate this Lease as to the balance of the Premises by written notice to City within thirty (30) days after such date; provided, however, that a condition to the exercise by Tenant of such right to terminate shall be that the portion of the Premises taken shall be of such extent and nature as to materially impair Tenant's use of the balance of the Premises as a Communications Site. In the event of a partial taking of the Premises which does not result in a termination of this Lease, the Base Rent and Additional Charges thereafter to be paid shall be equitably reduced.

If any material part of the Building shall be taken as a result of the exercise of the power of eminent domain or any transfer in lieu thereof, City shall have the right to terminate this Lease by written notice to Tenant within thirty (30) days of the date of the taking.

In the event of any taking, City shall be entitled to any award which may be paid or made in connection therewith. Tenant shall have no claim against City for the value of any unexpired term of this Lease or otherwise except that Tenant may claim any portion of the award that is specifically allocable to Tenant's relocation expenses or the interruption of or damage to Tenant's business or loss or damage to Tenant's Property.

The parties understand and agree that the foregoing provisions of this Section are intended to govern fully the rights and obligations of the parties in the event of a taking. Tenant and City each hereby waives and releases any right to terminate this Lease in whole or in part under Sections 1265.120 and 1265.130 of the California Code of Civil Procedure (partial termination of lease and Court order terminating lease, respectively) or under any similar law, statute or ordinance now or hereafter in effect.

16.2 Temporary Takings

Notwithstanding the foregoing, if a taking occurs with respect to all or any portion of the Premises for less than ninety (90) days, this Lease shall remain unaffected thereby, and Tenant shall continue to perform all of the terms, conditions and covenants of this Lease, except that Tenant shall be entitled to an abatement in Base Rent to the extent that its use of the Premises as a Communications Site is materially impaired. In the event of any such temporary taking, Tenant shall be entitled to receive that portion of any award which represents compensation for the use or occupancy of the Premises during the Term up to the total Base Rent and Additional Charges owing by Tenant for the period of the taking, and City shall be entitled to receive the balance of any award.

17. ASSIGNMENT AND SUBLETTING

17.1 Restriction on Assignment and Subletting

Tenant shall not directly or indirectly (including, without limitation, by merger, acquisition, or other transfer of any controlling interest in Tenant), voluntarily or by operation of law, sell, assign, encumber, pledge or otherwise transfer any part of its interest in or rights with respect to the Premises or its leasehold estate hereunder (collectively, "Assignment"), or permit any portion of the Premises to be occupied by anyone other than itself, or sublet any portion of the Premises (collectively, "Sublease"), without City's prior written consent. City's consent shall not be unreasonably withheld in each instance, as provided hereinbelow and subject to the exception for certain permitted transfers as provided in Section 17.6 (Permitted Assignment). Notwithstanding anything to the contrary contained in this Lease, in no event shall Tenant have the right to encumber by a mortgage, deed of trust, security agreement, or otherwise, any part of the Premises, the Building or City's interest therein.

17.2 Notice of Proposed Transfer

If Tenant desires to enter into an Assignment or a Sublease, then it shall give written notice (a "Notice of Proposed Transfer") to City of its intention to do so. The Notice of Proposed Transfer shall provide in detail the terms and conditions for such proposed Assignment or Sublease and complete information, including financial statements, business history, and references about the Assignee or Sublessee and such other information about the proposed assignee or subtenant (collectively, "Transferee") as is reasonably requested by City to make a fully informed decision about consent to Tenant's request.

17.3 City's Response

City shall make its election to approve or disapprove such Assignment or Sublease within twenty (20) business days after City's receipt of the Notice of Proposed Transfer (the "Response Period"). If City approves the proposed Sublease or Assignment in writing, then Tenant shall be entitled for a period of ninety (90) days following such date to enter into the proposed Assignment or Sublease. However, any Rent or other consideration realized by Tenant under any such Assignment or Sublease in excess of the Base Rent and Additional Charges payable hereunder (or the amount thereof proportionate to the portion of the Premises subject to such Sublease) shall be paid to City after Tenant has recovered any reasonable broker's commissions and the reasonable cost of any improvements that Tenant has actually incurred in connection with such Sublease or Assignment.

Notwithstanding anything to the contrary in this Section, if any monetary or other material event of default by Tenant is outstanding hereunder at the time of Tenant's Notice of Proposed Transfer (or if any event shall have occurred which with the giving of notice or the passage of time or both would constitute such a default), then City may elect by notice to Tenant

to refuse to consent to Tenant's proposed Transfer and pursue any of its right or remedies hereunder or at law or in equity.

17.4 Effect of Sublease or Assignment

No Sublease or Assignment by Tenant nor any consent by City thereto shall relieve Tenant of any obligation on its part under this Lease. Any Sublease or Assignment that is not in compliance with this Section shall be void and, at City's option, shall constitute a material default by Tenant under this Lease. The acceptance of any Base Rent or other payments by City from a proposed Transferee shall not constitute consent to such Sublease or Assignment by City or a recognition of any Transferee, or a waiver by City of any failure of Tenant or other transferor to comply with this Section.

17.5 Assumption by Transferee

Each Transferee shall assume all obligations of Tenant under this Lease and shall be and remain liable jointly and severally with Tenant for the payment of the Base Rent and Additional Charges, and for the performance of all of the terms, covenants, conditions and agreements herein contained on Tenant's part to be performed. No Assignment shall be binding on City unless Tenant or Transferee shall deliver to City evidence satisfactory to City that it has obtained all permits, licenses, or other approvals required to operate as a wireless telecommunications service provider on the Premises, a counterpart of the Assignment (or other document reasonably satisfactory to the City in the event of an assignment permitted under Section 17.6 (Permitted Assignment)) and an instrument in recordable form that contains a covenant of assumption by such Transferee satisfactory in substance and form to City, and consistent with the requirements of this Section. However, the failure or refusal of such Transferee to execute such instrument of assumption shall not release such Transferee from its liability as set forth above. Except for a permitted assignment to a general partner or affiliate of Tenant as provided in Section 17.6, Tenant shall reimburse City on demand for any reasonable costs that may be incurred by City in connection with any proposed Sublease or Assignment, including, without limitation, the costs of making investigations as to the acceptability of the proposed Transferee and legal costs incurred in connection with the granting of any requested consent.

17.6 Permitted Assignment

City agrees that Tenant shall be permitted to enter into an Assignment of this Lease or Sublease of the Premises, without City's prior consent but with notice to City as provided below, to any entity which directly or indirectly controls, is controlled by or is under the common control with, Tenant, and has a net worth of at least Ten Million Dollars (\$10,000,000.00), will use the Premises in the same manner as Tenant under this Lease and holds all licenses, permits, and other approvals necessary to lawfully operate a Communications Site on the Premises. As used above, the term "control" shall mean (a) as to a corporation, the ownership of stock having the right to exercise more than fifty percent (50%) of the total combined voting power of all classes of stock of the controlled corporation, issued and outstanding, and (b) as to partnerships and other forms of business associations, ownership of more than fifty percent (50%) of the beneficial interest and voting control of such association. Tenant shall use its best efforts to provide City with notice in advance of any such permitted Assignment and in any event shall provide City with written notice no later than ten (10) days after the effective date of such permitted Assignment.

18. DEFAULT

18.1 Events of Default

Any of the following shall constitute an event of default by Tenant hereunder:

(a) any failure to pay any Base Rent or Additional Charges as and when due, provided Tenant shall have a period of ten (10) days from the date of written notice from City within which to cure any default in the payment of Rent; provided, however, that City shall not be required to provide such notice regarding Tenant's failure to make such payments when due more than twice during any calendar year, and any such failure by Tenant after Tenant has received two such notices in any calendar year from City shall constitute a default by Tenant hereunder without any requirement on the part of City to give Tenant notice of such failure except for a three (3)-day notice to pay or quit as required by law;

(b) any failure to perform or comply with any other covenant, condition or representation made under this Lease, provided Tenant shall have a period of thirty (30) days from the date of written notice from City within which to cure such default under this Lease, or, if such default is not capable of cure within such thirty (30)-day period, Tenant shall have a reasonable period to complete such cure if Tenant promptly undertakes action to cure such default within such thirty (30)-day period and thereafter diligently prosecutes the same to completion and Tenant uses its best efforts to complete such cure within sixty (60) days after written notice of default from City;

(c) any vacation or abandonment of the Premises for more than fourteen (14) consecutive days such that the Premises are no longer being used for the purposes set forth in Section 6.1; City acknowledges that the Premises are to be used as an unoccupied transmission facility and, accordingly, lack of on-site personnel shall not, in and of itself, be deemed to indicate vacation or abandonment; and

(d) the appointment of a receiver due to Tenant's insolvency to take possession of all or substantially all of the assets of Tenant, or an assignment by Tenant for the benefit of creditors, or any action taken or suffered by Tenant under any insolvency, bankruptcy, reorganization, moratorium or other debtor relief act or statute, whether now existing or hereafter amended or enacted, if any such receiver, assignment or action is not released, discharged, dismissed or vacated within sixty (60) days.

18.2 Remedies

Upon the occurrence of an event of default by Tenant which is not cured by Tenant within the applicable grace period, if any, specified in Section 18.1 (Events of Default), City shall have the following rights and remedies in addition to all other rights and remedies available to City at law or in equity:

(a) the rights and remedies provided by California Civil Code Section 1951.2 (damages on termination for breach), including, but not limited to, the right to terminate Tenant's right to possession of the Premises and to recover the worth at the time of award of the amount by which the unpaid Base Rent and Additional Charges for the balance of the Term after the time of award exceeds the amount of rental loss for the same period that Tenant proves could be reasonably avoided, as computed pursuant to subsection (b) of such Section 1951.2.

(b) the rights and remedies provided by California Civil Code Section 1951.4 (continuation of lease after breach and abandonment), which allows City to continue this Lease in effect and to enforce all of its rights and remedies under this Lease, including the right to recover rent as it becomes due, for so long as City does not terminate Tenant's right to possession. Acts of maintenance or preservation, efforts to relet the Premises or the appointment of a receiver upon City's initiative to protect its interest under this Lease shall not constitute a termination of Tenant's right to possession. If City exercises its right under California Civil Code Section 1951.4, City may from time to time sublet the Premises or any part thereof for such term or terms (which may extend beyond the Term) and at such rent and upon such other terms as City in its sole discretion may deem advisable, with the right to make alterations and repairs to

the Premises. Upon each such subletting, Tenant shall be immediately liable for payment to City of, in addition to Base Rent and Additional Charges due hereunder, the cost of such subletting and such alterations and repairs incurred by City and the amount, if any, by which the Base Rent and Additional Charges owing hereunder for the period of such subletting (to the extent such period does not exceed the Term) exceeds the amount to be paid as Base Rent and Additional Charges for the Premises for such period pursuant to such subletting. No action taken by City pursuant to this Subsection shall be deemed a waiver of any default by Tenant and, notwithstanding any such subletting without termination, City may at any time thereafter elect to terminate this Lease for such previous default.

(c) the right to have a receiver appointed for Tenant upon application by City to take possession of the Premises and to apply any rental collected from the Premises and to exercise all other rights and remedies granted to City pursuant to this Lease.

19. TENANT'S INDEMNITY

Tenant, on behalf of itself and its successors and assigns, shall indemnify, defend and hold harmless ("Indemnify") City, its Agents and Invitees, and their respective heirs, legal representatives, successors and assigns (individually and collectively, the "Indemnified Parties"), and each of them, from and against any and all liabilities, losses, costs, claims, judgments, settlements, damages, liens, fines, penalties and expenses, including, without limitation, direct and vicarious liability of every kind (collectively, "Claims"), incurred in connection with or arising in whole or in part from: (a) injury to or death of a person, including, without limitation, employees of Tenant, or loss of or damage to property, occurring on or about the Premises or License Areas or arising in connection with the use of the Premises or License Areas under this Lease; (b) any default by Tenant in the observation or performance of any of the terms, covenants or conditions of this Lease to be observed or performed on Tenant's part; (c) the use or occupancy or manner of use or occupancy of the Premises by Tenant, its Agents or Invitees or any person or entity claiming through or under any of them; (d) the condition of the Premises or any occurrence on the Premises from any cause attributable to the events described in clauses (a), (b) or (c) of this Section; or (e) any acts, omissions or negligence of Tenant, its Agents or Invitees, in, on or about the Premises or the Building; all regardless of the negligence of, and regardless of whether liability without fault is imposed or sought to be imposed on, the Indemnified Parties, except to the extent that such Indemnity is void or otherwise unenforceable under applicable Law in effect on or validly retroactive to the date of this Lease and further except to the extent such Claim is caused by the willful misconduct or active negligence of the Indemnified Parties. The foregoing Indemnity shall include, without limitation, reasonable fees of attorneys, consultants and experts and related costs and City's costs of investigating any Claim. Tenant specifically acknowledges and agrees that it has an immediate and independent obligation to defend City and the other Indemnified Parties from any claim which actually or potentially falls within this indemnity provision even if such allegation is or may be groundless, fraudulent or false, which obligation arises at the time such claim is tendered to Tenant by City and continues at all times thereafter. Tenant's obligations under this Section shall survive the termination of the Lease.

20. INSURANCE

20.1 Tenant's Insurance

(a) Tenant shall procure and keep in effect at all times during the Term, at Tenant's cost, insurance in the following amounts and coverages:

(i) Commercial General Liability Insurance with limits not less than Two Million Dollars (\$2,000,000) each occurrence combined single limit for bodily injury and

property damage, including contractual liability, personal injury, products and completed operations.

(ii) Workers' Compensation Insurance with Employer's Liability Limits not less than One Million Dollars (\$1,000,000) each accident.

(iii) Commercial Automobile Liability Insurance with limit not less than One Million Dollars (\$1,000,000) each occurrence combined single limit for bodily injury and property damage, including owned and non-owned and hired vehicles.

(iv) Business Interruption Insurance insuring that the Rent will be paid to City for a period of at least one (1) year if Tenant is unable to operate its business at the Premises. Such insurance shall also cover business interruptions due to failures or interruptions in telecommunications services, strikes, employee lockouts, riots, or other civil commotion.

(b) Commercial General Liability, Commercial Automobile Liability Insurance and Business Interruption Insurance policies shall be endorsed to provide the following:

(i) Name as an additional insured the City and County of San Francisco, its officers, agents and employees.

(ii) That such policies are primary insurance to any other insurance available to the additional insureds, with respect to any claims arising out of the failure of Tenant or its Agents to comply with this Lease or for which Tenant is obligated to Indemnify the Indemnified Parties under Section 19 above, and that insurance applies separately to each insured against whom claim is made or suit is brought. Such policies shall also provide for severability of interests.

(c) All insurance policies required to be maintained by Tenant hereunder shall be endorsed to provide City with thirty (30) days' prior written notice of cancellation for any reason, non-renewal, or reduction in coverage below the limits required herein. Notice to City shall be mailed to the address(es) for City set forth in the Basic Lease Information.

(d) Should any of the required insurance be provided under a claims-made form, Tenant shall maintain such coverage continuously throughout the term hereof and, without lapse, for a period of three (3) years beyond the expiration or termination of this Lease, to the effect that, should occurrences during the Term give rise to claims made after expiration or termination of this Lease, such claims shall be covered by such claims-made policies.

(e) Should any of the required insurance be provided under a form of coverage that includes a general annual aggregate limit or provides that claims investigation or legal defense costs be included in such general annual aggregate limit, such general aggregate limit shall double the occurrence or claims limits specified above.

(f) Tenant shall deliver to City certificates of insurance and additional insured policy endorsements from insurers in a commercially reasonable form, evidencing the coverages required hereunder, on or before the Commencement Date, and Tenant shall provide City with certificates thereafter promptly upon City's request. In the event of a claim involving coverage dispute, Tenant shall provide the City with copies of the relevant policies through the parties' attorneys.

(g) Tenant's compliance with the provisions of this Section shall in no way relieve or decrease Tenant's liability under Section 19 (Indemnity), or any other provision of this Lease.

(h) Notwithstanding anything to the contrary in this Lease, City may elect, in City's sole and absolute discretion, to terminate this Lease if Tenant allows any required insurance coverage to lapse by: (1) providing Tenant written notice of such lapse; and (2) immediately providing written notice of termination if Tenant fails to reinstate the lapsed coverage within three (3) days of City's notice of such default.

20.2 Tenant's Property

Tenant shall be responsible, at its expense, for separately insuring Tenant's Property.

20.3 City's Self Insurance

Tenant acknowledges that City self-insures against casualty, property damage and public liability risks. City agrees to maintain an adequate program of self-insurance for public liability risks during the Term and shall not be required to carry any third party insurance with respect to the Building, the Premises or otherwise.

20.4 Waiver of Subrogation

Notwithstanding anything to the contrary contained herein, City and Tenant each hereby waives any right of recovery against the other party for any loss or damage sustained by such other party with respect to the Building or the Premises or any portion thereof or the contents of the same or any operation therein, whether or not such loss is caused by the fault or negligence of such other party, to the extent such loss or damage is covered by third party insurance to be obtained by the waiving party under this Lease or is actually covered by insurance obtained by the waiving party. Each waiving party agrees to cause its third party insurers to issue appropriate waiver of subrogation rights endorsements to all policies relating to the Building or the Premises; provided, the failure to obtain any such endorsement shall not affect the above waiver.

21. LIMITATION OF CITY'S LIABILITY

21.1 Limitation on City's Liability

City shall not be responsible for or liable to Tenant, and Tenant hereby waives all Claims against City and its Agents and releases City and its Agents from, all Claims for any injury, loss or damage to any person or property in or about the Premises or any License Area created under this Lease by or from any cause whatsoever (other than to the extent caused by the active negligence or willful misconduct of City and its Agents), including, without limitation, acts or omissions of persons occupying adjoining premises or any part of the Building adjacent to or connected with the Premises; theft; burst, stopped or leaking water, gas, sewer or steam pipes; or gas, fire, oil or electricity in, on or about the Premises or the Building.

21.2 Consequential Damages

Tenant expressly acknowledges and agrees that the Rent payable hereunder does not take into account any potential liability of City for any consequential or incidental damages including, but not limited to, lost profits arising from the disruption to Tenant Improvements. City would not be willing to enter into this Lease in the absence of a complete waiver of liability, to the fullest extent permitted by Law, for consequential or incidental damages due to the acts or omissions of City or its Agents, and Tenant expressly assumes the risk with respect thereto. Accordingly, without limiting any indemnification obligations of Tenant or other waivers contained in this Lease and as a material part of the consideration for this Lease, Tenant fully releases, waives and discharges forever any and all claims, demands, rights, and causes of action against City for consequential and incidental damages (including without limitation, lost profits) arising out of this Lease, including, without limitation, any interference with uses conducted by

Tenant pursuant to this Lease, regardless of the cause, and whether or not due to the active or passive negligence or willful misconduct of City or its Agents, and covenants not to sue for such damages City, its departments, commissions, officers, directors and employees, and all persons acting by, through or under each of them.

21.3 No Relocation Assistance

This Lease creates no right in Tenant to receive any relocation assistance or payment for any reason under the Relocation Assistance Act (California Government Code Section 7260 et seq.), the Uniform Relocation Assistance Act (42 U.S.C. Section 4602 et seq.) as such acts may be amended or revised or under any existing or future law upon any termination of tenancy except as provided in Section 16 (Eminent Domain) hereof.

Tenant fully waives, releases and relinquishes forever any and all claims, demands, rights and causes of action that it may have against the city under any existing or future laws, for any compensation from City not otherwise provided for herein, upon any termination of tenancy hereunder.

In connection with the releases under Sections 21.1 (Limitation on City's Liability), 21.2 (Consequential Damages), and 21.3 (No Relocation Assistance), Tenant acknowledges that it is familiar with Section 1542 of the California Civil Code, which reads:

A GENERAL RELEASE DOES NOT EXTEND TO CLAIMS WHICH
THE CREDITOR DOES NOT KNOW OR SUSPECT TO EXIST IN HIS
OR HER FAVOR AT THE TIME OF EXECUTING THE RELEASE,
WHICH IF KNOWN BY HIM OR HER MUST HAVE MATERIALLY
AFFECTED HIS OR HER SETTLEMENT WITH THE DEBTOR.

Tenant acknowledges that the releases contained herein include all known and unknown, disclosed and undisclosed, anticipated and unanticipated claims. Tenant realizes and acknowledges that it has agreed upon this Lease in light of this realization and, being fully aware of this situation, it nevertheless intends to waive the benefit of Civil Code Section 1542, or any statute or other similar law now or later in effect. The releases contained herein shall survive any termination of this Lease.

22. ACCESS TO PREMISES

22.1 Tenant's Access to the Premises

City hereby grants to Tenant during the Term of this Lease and for the limited purposes and subject to the terms and conditions set forth below, a nonexclusive license in and over the following common areas of the Building to the Premises: areas providing physical access by personnel and equipment including ramps, loading docks, walkways, staircases, and ladders; and the roof of the elevator room on which Tenant's Equipment is installed as shown on Exhibit C. Use of such areas shall be subject to City's rights under Section 9 (City's Alterations of Building and Building Systems). The license granted to Tenant hereunder is for the sole purpose of constructing, maintaining, restoring, replacing and operating Tenant's Equipment located within the Premises or the common areas of the Building, including any necessary electrical and telephone conduits, in accordance with the use permitted under this Lease. Such rights shall include the right of ingress and egress through the Building during non-business hours for access to or from the Premises or Tenant's Equipment, provided that Tenant shall notify Rob Reiter, or any other person designated by City, at least twenty-four (24) hours in advance of any access and shall comply with all reasonable requirements of such designated person with respect to Tenant's requested access. In the event of an emergency, Tenant shall have the right to enter the Premises provided it makes good faith efforts if possible to notify City, or City's designated person, in

advance of such entry. The foregoing license is irrevocable until this Lease expires or sooner terminates as provided herein.

22.2 City's Access to the Premises

City and its designated Agents shall the right to enter the Premises at all reasonable times upon not less than twenty-four (24) hours advance notice (except in the event of an emergency) for any of the following purposes:

- (a) To determine whether the Premises are in good condition and to inspect the Premises;
- (b) To determine whether Tenant is in compliance with its obligations hereunder and to cure or attempt to cure any default in accordance with the provisions of Section 18.2 (Remedies) hereof;
- (c) To serve, post or keep posted any notices required or allowed under any provisions of this Lease or required under any applicable Law;
- (d) To do any maintenance or repairs to the Premises that City has the right or the obligation, if any, to perform hereunder; and
- (e) To show the Premises to any prospective purchasers, brokers, encumbrancers or officials, or, during the last year of the Term of this Lease, to exhibit the Premises to prospective tenants or other occupants, and to post any "for sale" or "for lease" signs in connection therewith.

22.3 Emergency Access

In the event of any emergency, as determined by City, City may, at its sole option and without notice (provided that City shall make reasonable efforts to provide Tenant with notice when feasible in light of the exigent circumstances) enter the Premises and alter or remove Tenant's Property on or about the Premises. City shall have the right to use any and all means City considers appropriate to gain access to any portion of the Premises in an emergency. In such case, City shall not be responsible for any damage or injury to any such property, nor for the replacement of any such property and any such emergency entry shall not be deemed to be a forcible or unlawful entry onto or a detainer of, the Premises, or any eviction, actual or constructive, of Tenant from the Premises or any portion thereof.

22.4 No Liability

City shall not be liable in any manner, and Tenant hereby waives any claims, for any inconvenience, disturbance, loss of business, nuisance or other damage arising out of City's entry onto the Premises, except damage resulting directly and exclusively from the gross negligence or willful misconduct of City or its Agents and not contributed to by the acts, omissions or negligence of Tenant, its Agents or Invitees.

22.5 No Abatement

Tenant shall not be entitled to any abatement in Rent if City exercises any rights reserved in this Section 22.

22.6 Minimize Disruption

City shall use its reasonable good faith efforts to conduct any activities on the Premises allowed under this Section 22 in a manner that, to the extent practicable, will minimize any disruption to Tenant's use hereunder.

23. ESTOPPEL CERTIFICATES

Tenant, at any time and from time to time upon not less than ten (10) days' and after receipt of written notice from City, shall execute, acknowledge and deliver to City or to any party designated by City, a certificate of Tenant stating: (a) that Tenant has accepted the Premises (or, if Tenant has not done so, that Tenant has not accepted the Premises and specifying the reasons therefor), (b) the Commencement Date and Expiration Date of this Lease, (c) that this Lease is unmodified and in full force and effect (or, if there have been modifications, that the Lease is in full force and effect as modified and stating the modifications), (d) whether or not there are then existing any defenses against the enforcement of any of the obligations of Tenant under this Lease (and if so, specifying the same), (e) whether or not there are then existing obligations of City under this Lease (and if so specifying the same), (f) the dates, if any, to which the Base Rent and Additional Charges have been paid, and (g) any other information that may be required by any such persons.

24. RULES AND REGULATIONS

Tenant shall faithfully comply with any and all reasonable rules, regulations and instructions, written or oral which may be established during the Term by City with respect to use of any part of the Building.

25. SECURITY DEPOSIT

Upon execution of this Lease, Tenant shall deposit with City the sum specified as the security deposit in the Basic Lease Information (the "Security Deposit"), in cash, to secure Tenant's faithful performance of all terms, covenants and conditions of this Lease. Tenant agrees that City may (but shall not be required to) apply the Security Deposit in whole or in part to remedy any damage to the Premises caused by Tenant, its Agents or Invitees, or any failure of Tenant to perform any other terms, covenants or conditions contained herein (including, but not limited to, the payment of Rent or other sum due hereunder either before or after a default), without waiving any of City's other rights and remedies hereunder or at law or in equity and without any obligation. Tenant waives the provisions of Section 1950.7 of the California Civil Code or any similar law, statute or ordinance now or hereafter in effect and agrees that Landlord may retain any portion of Security Deposit reasonably necessary to compensate Landlord for any other foreseeable or unforeseeable loss or damage caused by the acts or omissions of Tenant, its Agents or Invitees. Without limiting the foregoing, Tenant understands and agrees that Landlord may apply some or all of the Security Deposit to the payment of future Rent following a Tenant default.

Should City use any portion of the Security Deposit to cure any default by Tenant hereunder, Tenant shall immediately replenish the Security Deposit to the original amount. If the Base Rent is increased pursuant to any of the provisions of this Lease, Tenant shall increase the amount of the Security Deposit accordingly. City's obligations with respect to the Security Deposit are solely that of debtor and not trustee. City shall not be required to keep the Security Deposit separate from its general funds, and Tenant shall not be entitled to interest on the Security Deposit. The amount of the Security Deposit shall in no way limit the liabilities of Tenant under any provision of this Lease.

26. SURRENDER OF PREMISES

Upon the Expiration Date or other termination of this Lease, Tenant shall peaceably quit and surrender to City the Premises in good order and condition, normal wear and tear excepted, free of debris and hazards, after having made the last necessary repair required by Tenant under this Section (and damage caused by casualty or condemnation excepted). The Premises shall be surrendered free and clear of all liens and encumbrances other than presently existing liens and encumbrances and any other encumbrances created by City. Tenant shall, immediately before the Expiration Date or other termination of this Lease, remove all of Tenant's Property as provided in Section 8.2 (Title to and Removal of Tenant Improvements), and repair any damage resulting from the removal. Tenant's obligations under this Section shall survive the Expiration Date or other termination of this Lease. Any items of Tenant's Property which shall remain in the Premises after the Expiration Date of this Lease may, at the option of City, be deemed abandoned and in such case may be disposed of by City in accordance with Civil Code Section 1980 et seq. or any other manner allowed by law.

Concurrently with the surrender of the Premises as provided above, Tenant agrees, if requested by City, to execute, acknowledge and deliver to City a quitclaim deed to the Premises and any other instrument reasonably requested by City to evidence or otherwise effect the termination of Tenant's leasehold estate hereunder and to effect such transfer or vesting of title to the Tenant Improvements or other improvements or equipment which are to remain part of the Premises as provided herein.

27. HAZARDOUS MATERIALS

27.1 Definitions

As used herein, the following terms shall have the meanings set forth below:

(a) "Environmental Laws" shall mean any federal, state, local or administrative law, rule, regulation, order or requirement relating to industrial hygiene, environmental conditions or Hazardous Materials, whether now in effect or hereafter adopted.

(b) "Hazardous Material" shall mean any material that, because of its quantity, concentration or physical or chemical characteristics, is at any time now or hereafter deemed by any federal, state or local governmental authority to pose a present or potential hazard to human health, welfare or safety or to the environment. Hazardous Material includes, without limitation, any material or substance defined as a "hazardous substance," or "pollutant" or "contaminant" pursuant to the Comprehensive Environmental Response, Compensation and Liability Act of 1980 ("CERCLA", also commonly known as the "Superfund" law), as amended, (42 U.S.C. Section 9601 et seq.) or pursuant to Section 25316 of the California Health & Safety Code; any "hazardous waste" listed pursuant to Section 25140 of the California Health & Safety Code; and petroleum, including crude oil or any fraction thereof, natural gas or natural gas liquids.

(c) "Investigate and Remediate" shall mean the undertaking of any activities to determine the nature and extent of Hazardous Material that may be located in, on, under or about the Property or that has been, is being or threatens to be Released into the environment, and to clean up, remove, contain, treat, stabilize, monitor or otherwise control such Hazardous Material.

(d) "Release" when used with respect to Hazardous Material shall include any actual or imminent spilling, leaking, pumping, pouring, emitting, emptying, discharging, injecting, escaping, leaching, dumping, or disposing into or inside the Building, or in, on, under or about the Property or the environment.

27.2 Hazardous Materials in Premises

Tenant covenants and agrees that neither Tenant nor any of its Agents or Invitees shall cause or permit any Hazardous Material to be brought upon, kept, used, stored, generated, disposed of or Released in, on or about the Premises or any other part of the Property, or transported to or from the Property in violation of Environmental Laws, except that Tenant may use small quantities of Hazardous Materials as needed for routine cleaning and maintenance of Tenant's Equipment which are customarily used for routine cleaning and maintenance of such equipment and so long as all such materials are handled and used in compliance with Environmental Laws. Tenant shall immediately notify Landlord if and when Tenant learns or has reason to believe there has been any Release of Hazardous Material on or about the Premises or the Property.

27.3 Tenant's Environmental Indemnity

If Tenant breaches any of its obligations contained in this Section, or if any act, omission or negligence of Tenant or any of its Agents or Invitees results in any contamination of the Premises or any other part of the Property or in a Release of Hazardous Material from, on, about, in, or beneath any part of the Premises or the Property or the violation of any Environmental Law, then in any such event Tenant, on behalf of itself and its successors and assigns, shall Indemnify City, its Agents and Invitees, and their respective successors and assigns, and each of them, from and against any and all Claims (including, without limitation, damages for decrease in value of the Premises or the Property, the loss or restriction of the use of rentable or usable space or of any amenity of the Premises or the Property and sums paid in settlement of claims, attorneys' fees, consultants' fees and experts' fees) arising during or after the Term of this Lease relating to such Release or violation of Environmental Laws; provided, however, Tenant shall not be liable for any Claims to the extent such Release was caused by the active negligence or willful misconduct of City or its Agents. The foregoing Indemnity includes, without limitation, costs incurred in connection with any activities required to Investigate and Remediate any Hazardous Material brought onto the Premises or the Property by Tenant or any of its Agents or Invitees and to restore the Property to its condition prior to Tenant's introduction of such Hazardous Material or the correction of any violation of Environmental Laws. Tenant specifically acknowledges and agrees that it has an immediate and independent obligation to defend City and the other Indemnified Parties from any claim which actually or potentially falls within this indemnity provision even if such allegation is or may be groundless, fraudulent or false, which obligation arises at the time such claim is tendered to Tenant by City and continues at all times thereafter. Without limiting the foregoing, if Tenant or any of its Agents or Invitees cause the Release of any Hazardous Material on , about, in, or beneath the Premises or Property, then in any such event Tenant shall, immediately, at no expense to City, take any and all necessary actions to return the Premises or the Property, as applicable, to the condition existing prior to the Release of any such Hazardous Materials on the Property or otherwise abate the Release in accordance with all Environmental Laws, except to the extent such Release was caused by the active negligence of City or its Agents. Tenant shall afford City a full opportunity to participate in any discussions with governmental regulatory agencies regarding any settlement agreement, cleanup or abatement agreement, consent decree, or other compromise or proceeding involving Hazardous Material.

28. SPECIAL PROVISIONS

28.1 Extension Options

(a) Options to Extend Term

Subject to City's rights under Sections 28.3 (City's Right to Terminate) and 28.4 (City's Protection Against Interference), City grants to Tenant two (2) options to extend the Term of this

Lease (each, an "Extension Option"), each for an additional five (5) years (each, an "Extended Term"). Any such notice by Tenant shall be irrevocable by Tenant except as provided in Section 28.1(b) (Base Rent and Other Terms). If any material event of default by Tenant is outstanding hereunder either on the date which is ninety (90) days prior to the expiration of the Initial Term or the first Extended Term, as applicable, at any time prior to the first day of the Extended Term (or if any event has occurred which with the giving of notice or the passage of time or both would constitute a material event of default and such event has not been cured prior to the earlier of expiration of any applicable cure period under this Lease or the expiration of the Initial Term or the first Extended Term, as applicable.), then City may elect by notice to Tenant to reject Tenant's exercise of the Extension Option, whereupon the Extension Option (and any subsequent Extension Option) shall be null and void.

(b) Base Rent and Other Terms

If Tenant elects to exercise any of the Extension Options, then the lease for the applicable Extended Term shall cover the entire Premises and shall be upon all of the terms, covenants and conditions of this Lease, and Base Rent hereunder shall be set at the greater of:

- i. The City's minimum base rent for telecom installations atop City-owned assets within major traffic corridors; or
- ii. An amount equal to one hundred three percent (103%) of the Base Rent payable immediately prior to the commencement of such Extended Term.

28.2 Tenant's Right to Terminate

In the event Tenant loses its permits necessary to operate the Communications Site due to reasons other than its failure to comply with the conditions of the permit and in spite of reasonable efforts by Tenant to maintain its permits, Tenant may terminate this Lease with ninety (90) days' prior written notice to City. The parties do not intend that Tenant's right to terminate be used to relocate to a better site.

28.3 City's Right to Terminate Due to Finding by Board of Supervisors

City shall have the right to terminate this Lease without penalty upon ninety (90) days' written notice to Tenant if, after notice and public hearing and a reasonable time (not to exceed sixty (60) days) for Tenant to effect a remedy, the San Francisco Board of Supervisors determines that Tenant's continued use of the Premises will adversely affect public health and safety.

28.4 City's Protection Against Interference

So long as Tenant is not in default hereunder, after the Commencement Date City shall not grant a lease for the Building if such use would materially adversely interfere with Tenant's normal operation of the Communications Site. Any such future lease of the Building to a third party that permits the installation of communication equipment shall be conditioned upon such third party not causing measurable interference which materially impairs Tenant's ability to utilize the Premises for its intended purpose.

28.5 Tenant's Protection Against Interference

Tenant will not permit its equipment or use of the Premises as a Communications Site to cause interference with or impairment of City's 911 Public Communications Safety System or Citywide 800 MHz Radio System or other communication or computer equipment used by City or any of its Agents or tenants on the Property. Tenant will not use the Premises or Tenant's

Equipment in any way which interferes with any existing use of the Building prior to this Lease or any future use of the Building by City or its successors except as specifically set forth in Section 28.4 (City's Protection Against Interference) (including, without limitation, City's use of the Building as a municipal office Building or other building tenants' use as a commercial banking, with related radio, telephone and other communications transmission and reception), and such interference shall be deemed a material breach of this Lease by Tenant, which shall, upon notice from City, be responsible for terminating such interference. In the event any such interference does not cease promptly, the parties acknowledge that continuing interference may cause irreparable injury and, therefore, City shall have the right to bring action to enjoin such interference or to terminate this Lease immediately upon notice, at City's election. If any change in the nature of City's use of the Building during the Term results in measurable interference which materially impairs Tenant's normal operation of its equipment located on the Premises and, as a result of such interference, it is necessary to alter the Tenant Improvements or Tenant's other equipment located on the Premises, Tenant shall notify City of such interference, which notice shall include a detailed description of the necessary Alterations and a cost estimate therefor. Upon receipt of such notice, City shall have the right to terminate this Lease upon thirty (30) days' prior written notice to Tenant. If City elects not to terminate this Lease, Tenant may, at its election, either (i) make the Alterations described in such notice, in compliance with Section 8.1 (Tenant's Alterations) of this Lease, or (ii) terminate this Lease upon thirty (30) days' prior written notice to City. If Tenant elects to make such Alterations, Tenant shall offset the actual, documented cost incurred by Tenant to complete such Alterations against Base Rent as it comes due, up to a maximum amount equal to the lesser of (a) the cost estimate contained in Tenant's notice to City described above or (b) Ten Thousand Dollars (\$10,000.00).

29. GENERAL PROVISIONS

29.1 Notices

Any notice given under this Lease shall be effective only if in writing and given by delivering the notice in person, by sending it first class mail or certified mail with a return receipt requested or overnight mail, return receipt requested, with postage prepaid, to: (a) Tenant at Tenant's address set forth in the Basic Lease Information, or at any place where Tenant or any agent, officer or employee of Tenant may be personally served if sent subsequent to Tenant's vacating, deserting, abandoning or surrendering the Premises; or (b) Landlord at City's address set forth in the Basic Lease Information; or (c) to such other address as either City or Tenant may designate as its new address for such purpose by notice given to the other in accordance with the provisions of this Section. All notices hereunder shall be deemed to have been given or received two (2) days after the date when it shall have been mailed if sent by first class, certified or overnight mail, or upon the date personal delivery is made. Neither party may give official or binding notice by facsimile.

29.2 No Implied Waiver

No failure by either party to insist upon the strict performance of any obligation of the other under this Lease or to exercise any right, power or remedy arising out of a breach thereof, irrespective of the length of time for which such failure continues, shall constitute a waiver of such breach. No acceptance by any Agent of City of full or partial Base Rent or Additional Charges during the continuance of any such breach, and no acceptance of the keys to or possession of the Premises prior to the expiration of the Term by any Agent of City, shall constitute a waiver of such breach or of City's right to demand strict compliance with such term, covenant or condition or operate as a surrender of this Lease. No express written waiver by either party of any default or the performance of any provision hereof shall affect any other default or performance, or cover any other period of time, other than the default, performance or period of time specified in such express waiver. One or more written waivers of a default or the performance of any provision hereof by either party shall not be deemed to be a waiver of a

subsequent default or performance. The consent of City given in any instance under the terms of this Lease shall not relieve Tenant of any obligation to secure the consent of City in any other or future instance under the terms of this Lease.

29.3 Amendments

Neither this Lease nor any term or provisions hereof may be changed, waived, discharged or terminated orally, and no breach thereof shall be waived, altered or modified, except by a written instrument signed by both parties hereto.

29.4 Authority

If Tenant signs as a corporation or a partnership, each of the persons executing this Lease on behalf of Tenant does hereby covenant and warrant that Tenant is a duly authorized and existing entity, that Tenant is qualified to do business in California, that Tenant has full right and authority to enter into this Lease, and that each and all of the persons signing on behalf of Tenant are authorized to do so. Upon City's request, Tenant shall provide City with evidence reasonably satisfactory to City confirming the foregoing covenants and warranties.

29.5 Interpretation of Lease

The words "City" or "Landlord" and "Tenant" as used herein shall include the plural as well as the singular. If there is more than one Tenant, the obligations and liabilities under this Lease imposed on Tenant shall be joint and several. As used herein, the term "Agents" when used with respect to either party shall include the agents, employees, officers, contractors, subcontractors and representatives of such party, and the term "Invitees" when used with respect to either party shall include the clients, customers, invitees, guests, licensees, assignees or subtenants of such party. The captions preceding the articles and sections of this Lease and in the table of contents have been inserted for convenience of reference and such captions in no way define or limit the scope or intent of any provision of this Lease. This Lease has been negotiated at arm's length and between persons sophisticated and knowledgeable in the matters dealt with herein. Provisions in this Lease relating to number of days shall be calendar days, unless otherwise specified, provided that if the last day of any period to give notice, reply to a notice or to undertake any other action occurs on a Saturday, Sunday or a bank or City holiday, then the last day for undertaking the action or giving or replying to the notice shall be the next succeeding business day. All approvals, consents or other determinations permitted or required by City hereunder shall be made by or through City's Director of Property or his or her designee unless otherwise provided in this Lease, by City's Charter or City Ordinance.

29.6 Successors and Assigns

The terms, covenants and conditions contained in this Lease shall bind and inure to the benefit of City and Tenant and, except as otherwise provided herein, their personal representatives and successors and assigns; provided, however, that upon the sale, assignment or transfer by City named herein (or by any subsequent landlord) of its interest in the Building as owner or lessee, including any transfer by operation of law, City (or any subsequent landlord) shall be relieved from all subsequent obligations and liabilities arising under this Lease subsequent to such sale, assignment or transfer.

29.7 Brokers

Neither party has had any contact or dealings regarding the leasing of the Premises, or any communication in connection therewith, through any licensed real estate broker or other person who could claim a right to a commission or finder's fee in connection with this Lease except as identified in the Basic Lease Information whose commission, if any is due, shall be

paid pursuant to a separate written agreement between such broker and the party through which such broker contracted. In the event that any broker or finder perfects a claim for a commission or finder's fee based upon any such contact, dealings or communication, the party through whom the broker or finder makes his claim shall be responsible for such commission or fee and shall indemnify and hold harmless the other party from all claims, costs, and expenses (including, without limitation, reasonable attorneys' fees and disbursements) incurred by the indemnified party in defending against the same. The provisions of this Section shall survive any termination of this Lease.

29.8 Severability

If any provision of this Lease or the application thereof to any person, entity or circumstance shall be invalid or unenforceable, the remainder of this Lease, or the application of such provision to persons, entities or circumstances other than those as to which it is invalid or unenforceable, shall not be affected thereby, and to each provision of this Lease shall be valid and be enforced to the full extent permitted by law, except to the extent that enforcement of this Lease without the invalidated provision would be unreasonable or inequitable under all the circumstances or would frustrate a fundamental purpose of this Lease.

29.9 Governing Law

This Lease shall be construed and enforced in accordance with the laws of the State of California and City's Charter.

29.10 Entire Agreement

This instrument, including the exhibits hereto, which are made a part of this Lease, contains the entire agreement between the parties and all prior written or oral negotiations, understandings and agreements are merged herein. The parties further intend that this Lease shall constitute the complete and exclusive statement of its terms and that no extrinsic evidence whatsoever (including prior drafts hereof and changes therefrom) may be introduced in any judicial, administrative or other legal proceeding involving this Lease. Tenant hereby acknowledges that neither City nor City's Agents have made any representations or warranties with respect to the Premises, the Building or this Lease except as expressly set forth herein, and no rights, easements or licenses are or shall be acquired by Tenant by implication or otherwise unless expressly set forth herein.

29.11 Attorneys' Fee

In the event that either City or Tenant fails to perform any of its obligations under this Lease or in the event a dispute arises concerning the meaning or interpretation of any provision of this Lease, the defaulting party or the non-prevailing party in such dispute, as the case may be, shall pay the prevailing party reasonable attorneys' and experts' fees and costs, and all court costs and other costs of action incurred by the prevailing party in connection with the prosecution or defense of such action and enforcing or establishing its rights hereunder (whether or not such action is prosecuted to a judgment). For purposes of this Lease, reasonable attorneys' fees of the City's Office of the City Attorney shall be based on the fees regularly charged by private attorneys with the equivalent number of years of experience in the subject matter area of the law for which the City Attorney's services were rendered who practice in the City of San Francisco in law firms with approximately the same number of attorneys as employed by the Office of the City Attorney. The term "attorneys' fees" shall also include, without limitation, all such fees incurred with respect to appeals, mediations, arbitrations, and bankruptcy proceedings, and whether or not any action is brought with respect to the matter for which such fees were incurred. The term "costs" shall mean the costs and expenses of counsel to the parties, which may include printing, duplicating and other expenses, air freight charges, hiring of experts, and fees billed for

law clerks, paralegals, and others not admitted to the bar but performing services under the supervision of an attorney.

29.12 Holding Over

Any holding over after the expiration of the Term with the express consent of City shall be construed to automatically extend the Term of this Lease on a month to month basis at a Base Rent equal to one hundred fifty percent (150%) of the latest Base Rent payable by Tenant hereunder prior to such expiration, and shall otherwise be on the terms and conditions herein specified so far as applicable (except for those pertaining to the Term and any Extension Options). Any holding over without City's consent shall constitute a default by Tenant and entitle City to exercise any or all of its remedies as provided herein, notwithstanding that City may elect to accept one or more payments of Base Rent and Additional Charges from Tenant.

29.13 Time of Essence

Time is of the essence with respect to all provisions of this Lease in which a definite time for performance is specified.

29.14 Cumulative Remedies

All rights and remedies of either party hereto set forth in this Lease shall be cumulative, except as may otherwise be provided herein.

29.15 Survival of Indemnities

Termination of this Lease shall not affect the right of either party to enforce any and all indemnities and representations and warranties given or made to the other party under this Lease, nor shall it affect any provision of this Lease that expressly states it shall survive termination hereof.

29.16 Signs

Tenant agrees that it will not erect or maintain, or permit to be erected or maintained, any signs, notices or graphics upon or about the Premises which are visible in or from public corridors or other portions of any common areas of the Building or from the exterior of the Premises, without obtaining the prior written consent and approval of City, which City may withhold or grant in its sole discretion.

29.17 Light and Air

Tenant covenants and agrees that no diminution of light, air or view by any structure that may hereafter be erected (whether or not by City) shall entitle Tenant to any reduction of the Base Rent or Additional Charges under this Lease, result in any liability of City to Tenant, or in any other way affect this Lease or Tenant's obligations hereunder, except as described in Section 28.4 (City's Protection Against Interference).

29.18 Recording

Tenant agrees that it shall not record this Lease nor any memorandum or short form hereof in the Official Records of the City and County of San Francisco.

29.19 Taxes, Assessments, Licenses, Permit Fees and Liens

(a) Tenant recognizes and understands that this Lease may create a possessory interest subject to property taxation and that Tenant may be subject to the payment of property taxes levied on such interest. Tenant further recognizes and understands that any sublease or assignment permitted under this Lease and any exercise of any option to renew or extend this Lease may constitute a change in ownership for purposes of property taxation and therefore may result in a revaluation of any possessory interest created hereunder.

(b) Tenant agrees to pay taxes of any kind, including possessory interest taxes, that may be lawfully assessed on the leasehold interest hereby created and to pay all other taxes, excises, licenses, permit charges and assessments based on Tenant's usage of the Premises that may be imposed upon Tenant by law, all of which shall be paid when the same become due and payable and before delinquency. Tenant agrees not to allow or suffer a lien for any such taxes to be imposed upon the Premises or upon any equipment or property located thereon without promptly discharging the same, provided that Tenant, if so desiring, may have reasonable opportunity to contest the validity of the same.

(c) San Francisco Administrative Code Sections 23.38 and 23.39 require that the City and County of San Francisco report certain information relating to this Lease, and any renewals thereof, to the County Assessor within sixty (60) days after any such transaction; and that Tenant report certain information relating to any assignment of or sublease under this lease to the County Assessor within sixty (60) days after such assignment or sublease transaction. Tenant agrees to provide such information as may be requested by the City to enable the City to comply with this requirement.

29.20 Non-Liability of City Officials, Employees and Agents

No elective or appointive board, commission, member, officer, employee or agent of City shall be personally liable to Tenant, its successors and assigns, in the event of any default or breach by City or for any amount which may become due to Tenant, its successors and assigns, or for any obligation of City under this Lease.

29.21 Non-Discrimination in City Contracts and Benefits Ordinance

(a) Covenant Not to Discriminate

In the performance of this Lease, Tenant agrees not to discriminate against any employee, any City employee working with Tenant, or applicant for employment with Tenant, or against any person seeking accommodations, advantages, facilities, privileges, services, or membership in all business, social, or other establishments or organizations, on the basis of the fact or perception of a person's race, color, creed, religion, national origin, ancestry, age, height, weight, sex, sexual orientation, gender identity, domestic partner status, marital status, disability or Acquired Immune Deficiency Syndrome or HIV status (AIDS/HIV status), or association with members of such protected classes, or in retaliation for opposition to discrimination against such classes.

Tenant further acknowledges that the Americans with Disabilities Act requires that programs, services and other activities provided by a public entity to the public, whether directly or through a contractor, must be accessible to the disabled public. Subject to Section 11.1 (Compliance with Laws) hereof, Tenant acknowledges its obligation to comply with such Act and any other federal, state or local disability rights legislation. Tenant warrants that it will fulfill that obligation. Tenant also warrants that it will not discriminate against disabled persons in the provision of services, benefits or activities.

(b) Subleases and Other Subcontracts

Tenant shall include in all Subleases and other subcontracts relating to the Premises a non-discrimination clause applicable to such Subtenant or other subcontractor in substantially the form of subsection (a) above. In addition, Tenant shall incorporate by reference in all subleases and other subcontracts the provisions of Sections 12B.2(a), 12B.2(c)-(k), and 12C.3 of the San Francisco Administrative Code and shall require all subtenants and other subcontractors to comply with such provisions. Tenant's failure to comply with the obligations in this subsection shall constitute a material breach of this Lease.

(c) Non-Discrimination in Benefits

Tenant does not as of the date of this Lease and will not during the term of this Lease, in any of its operations in San Francisco, on real property owned by City, or where the work is being performed for the City or elsewhere within the United States, discriminate in the provision of bereavement leave, family medical leave, health benefits, membership or membership discounts, moving expenses, pension and retirement benefits or travel benefits, as well as any benefits other than the benefits specified above, between employees with domestic partners and employees with spouses, and/or between the domestic partners and spouses of such employees, where the domestic partnership has been registered with a governmental entity pursuant to state or local law authorizing such registration, subject to the conditions set forth in Section 12B.2(b) of the San Francisco Administrative Code.

(d) CMD Form

As a condition to this Lease, Tenant shall execute the "Chapter 12B Declaration: Nondiscrimination in Contracts and Benefits" form (Form CMD-12B-101) with supporting documentation and secure the approval of the form by the San Francisco Contract Monitoring Division. Tenant hereby represents that prior to execution of this Lease, (i) Tenant executed and submitted to the CMD Form CMD-12B-101 with supporting documentation, and (ii) the CMD approved such form.

(e) Incorporation of Administrative Code Provisions by Reference

The provisions of Chapters 12B and 12C of the San Francisco Administrative Code relating to non-discrimination by parties contracting for the lease of City property are incorporated in this Section by reference and made a part of this Lease as though fully set forth herein. Tenant shall comply fully with and be bound by all of the provisions that apply to this Lease under such Chapters of the Administrative Code, including but not limited to the remedies provided in such Chapters. Without limiting the foregoing, Tenant understands that pursuant to Section 12B.2(h) of the San Francisco Administrative Code, a penalty of Fifty Dollars (\$50) for each person for each calendar day during which such person was discriminated against in violation of the provisions of this Lease may be assessed against Tenant and/or deducted from any payments due Tenant.

29.22 Requiring Health Benefits for Covered Employees

Unless exempt, Tenant agrees to comply fully with and be bound by all of the provisions of the Health Care Accountability Ordinance (HCAO), as set forth in San Francisco Administrative Code Chapter 12Q, including the remedies provided, and implementing regulations, as the same may be amended from time to time. The provisions of Chapter 12Q are incorporated herein by reference and made a part of this Lease as though fully set forth. The text of the HCAO is available on the web at <http://www.sfgov.org/olse/hcao>. Capitalized terms used in this Section and not defined in this Lease shall have the meanings assigned to such terms in Chapter 12Q.

(a) For each Covered Employee, Tenant shall provide the appropriate health benefit set forth in Section 12Q.3 of the HCAO. If Tenant chooses to offer the health plan option, such health plan shall meet the minimum standards set forth by the San Francisco Health Commission.

(b) Notwithstanding the above, if the Tenant is a small business as defined in Section 12Q.3(d) of the HCAO, it shall have no obligation to comply with Subsection (a) above.

(c) Tenant's failure to comply with the HCAO shall constitute a material breach of this Lease. City shall notify Tenant if such a breach has occurred. If, within thirty (30) days after receiving City's written notice of a breach of this Lease for violating the HCAO, Tenant fails to cure such breach or, if such breach cannot reasonably be cured within such period of thirty (30) days, Tenant fails to commence efforts to cure within such period, or thereafter fails diligently to pursue such cure to completion, City shall have the right to pursue the remedies set forth in Section 12Q.5(f)(1-5). Each of these remedies shall be exercisable individually or in combination with any other rights or remedies available to City.

(d) Any Subcontract entered into by Tenant shall require the Subcontractor to comply with the requirements of the HCAO and shall contain contractual obligations substantially the same as those set forth in this Section. Tenant shall notify City's Purchasing Department when it enters into such a Subcontract and shall certify to the Purchasing Department that it has notified the Subcontractor of the obligations under the HCAO and has imposed the requirements of the HCAO on Subcontractor through the Subcontract. Each Tenant shall be responsible for its Subcontractors' compliance with this Chapter. If a Subcontractor fails to comply, the City may pursue the remedies set forth in this Section against Tenant based on the Subcontractor's failure to comply, provided that City has first provided Tenant with notice and an opportunity to obtain a cure of the violation.

(e) Tenant shall not discharge, reduce in compensation, or otherwise discriminate against any employee for notifying City with regard to Tenant's compliance or anticipated compliance with the requirements of the HCAO, for opposing any practice proscribed by the HCAO, for participating in proceedings related to the HCAO, or for seeking to assert or enforce any rights under the HCAO by any lawful means.

(f) Tenant represents and warrants that it is not an entity that was set up, or is being used, for the purpose of evading the intent of the HCAO.

(g) Tenant shall keep itself informed of the current requirements of the HCAO.

(h) Tenant shall provide reports to the City in accordance with any reporting standards promulgated by the City under the HCAO, including reports on Subcontractors and Subtenants, as applicable.

(i) Tenant shall provide City with access to records pertaining to compliance with HCAO after receiving a written request from City to do so and being provided at least five (5) business days to respond.

(j) City may conduct random audits of Tenant to ascertain its compliance with HCAO. Tenant agrees to cooperate with City when it conducts such audits.

(k) If Tenant is exempt from the HCAO when this Lease is executed because its amount is less than Twenty-Five Thousand Dollars (\$25,000) [Fifty Thousand Dollars (\$50,000) for nonprofits], but Tenant later enters into an agreement or agreements that cause Tenant's aggregate amount of all agreements with City to reach Seventy-Five Thousand Dollars

(\$75,000), all the agreements shall be thereafter subject to the HCAO. This obligation arises on the effective date of the agreement that causes the cumulative amount of agreements between Tenant and the Contracting Department to be equal to or greater than Seventy-Five Thousand Dollars (\$75,000) in the fiscal year.

29.23 MacBride Principles - Northern Ireland

The City and County of San Francisco urges companies doing business in Northern Ireland to move toward resolving employment inequities and encourages them to abide by the MacBride Principles as expressed in San Francisco Administrative Code Section 12F.1 et seq. The City and County of San Francisco also urges San Francisco companies to do business with corporations that abide by the MacBride Principles. Tenant acknowledges that it has read and understands the above statement of the City and County of San Francisco concerning doing business in Northern Ireland.

29.24 Drug-Free Workplace

Tenant acknowledges that pursuant to the Federal Drug-Free Workplace Act of 1989, the unlawful manufacture, distribution, possession or use of a controlled substance is prohibited on City premises. Tenant agrees that any violation of this prohibition by Tenant, its employees, agents or assigns shall be deemed a material breach of this Lease.

29.25 Tropical Hardwood and Virgin Redwood Ban

The City and County of San Francisco urges companies not to import, purchase, obtain or use for any purpose, any tropical hardwood or tropical hardwood wood product, virgin redwood or virgin redwood wood product except as expressly provided by the application of Sections 802(b) and 803(b) of the San Francisco Environment Code.

29.26 Pesticide Prohibition

Chapter 3 of the San Francisco Environment Code (the Integrated Pest Management Program Ordinance or "IPM Ordinance") describes an integrated pest management ("IPM") policy to be implemented by all City departments. Tenant shall not use or apply or allow the use or application of any pesticides on the Premises or contract with any party to provide pest abatement or control services to the Premises without first receiving City's written approval of an IPM plan that (i) lists, to the extent reasonably possible, the types and estimated quantities of pesticides that Tenant may need to apply to the Premises during the term of this Lease, (ii) describes the steps Tenant will take to meet the City's IPM Policy described in Section 300 of the IPM Ordinance and (iii) identifies, by name, title, address and telephone number, an individual to act as the Tenant's primary IPM contact person with the City. Tenant shall comply, and shall require all of Tenant's contractors to comply, with the IPM plan approved by the City and shall comply with the requirements of Sections 300(d), 302, 304, 305(f), 305(g), and 306 of the IPM Ordinance, as if Tenant were a City department. Among other matters, such provisions of the IPM Ordinance: (a) provide for the use of pesticides only as a last resort, (b) prohibit the use or application of pesticides on property owned by the City, except for pesticides granted an exemption under Section 303 of the IPM Ordinance (including pesticides included on the most current Reduced Risk Pesticide List compiled by City's Department of the Environment), (c) impose certain notice requirements, and (d) require Tenant to keep certain records and to report to City all pesticide use at the Premises by Tenant's staff or contractors.

29.27 Prohibition of Tobacco Sales and Advertising

Tenant acknowledges and agrees that no advertising or sale of cigarettes or tobacco products is allowed on the Premises. This advertising prohibition includes the placement of the

name of a company producing cigarettes or tobacco products or the name of any cigarette or tobacco product in any promotion of any event or product.

29.28 Prohibition of Alcoholic Beverage Advertising

Tenant acknowledges and agrees that no advertising of alcoholic beverages is allowed on the Premises. For purposes of this section, "alcoholic beverage" shall be defined as set forth in California Business and Professions Code Section 23004, and shall not include cleaning solutions, medical supplies and other products and substances not intended for drinking. This advertising prohibition includes the placement of the name of a company producing alcoholic beverages or the name of any alcoholic beverage in any promotion of any event or product

29.29 Preservative-Treated Wood Containing Arsenic

Tenant may not purchase preservative-treated wood products containing arsenic in the performance of this Lease unless an exemption from the requirements of Environment Code Chapter 13 is obtained from the Department of Environment under Section 1304 of the Environment Code. The term "preservative-treated wood containing arsenic" shall mean wood treated with a preservative that contains arsenic, elemental arsenic, or an arsenic copper combination, including, but not limited to, chromated copper arsenate preservative, ammoniac copper zinc arsenate preservative, or ammoniacal copper arsenate preservative. Tenant may purchase preservative-treated wood products on the list of environmentally preferable alternatives prepared and adopted by the Department of Environment. This provision does not preclude Tenant from purchasing preservative-treated wood containing arsenic for saltwater immersion. The term "saltwater immersion" shall mean a pressure-treated wood that is used for construction purposes or facilities that are partially or totally immersed in saltwater.

29.30 Conflicts of Interest

Through its execution of this Lease, Tenant acknowledges that it is familiar with the provisions of Section 15.103 of the San Francisco Charter, Article III, Chapter 2 of City's Campaign and Governmental Conduct Code, and Section 87100 et seq. and Section 1090 et seq. of the Government Code of the State of California, and certifies that it does not know of any facts which would constitute a violation of said provisions, and agrees that if Tenant becomes aware of any such fact during the term of this Lease, Tenant shall immediately notify the City.

29.31 Notification of Limitations on Contributions

Through its execution of this Lease, Tenant acknowledges that it is familiar with Section 1.126 of the San Francisco Campaign and Governmental Conduct Code, which prohibits any person who contracts with the City for the selling or leasing of any land or building to or from the City whenever such transaction would require approval by a City elective officer or the board on which that City elective officer serves, from making any campaign contribution to (1) an individual holding a City elective office if the contract must be approved by the individual, a board on which that individual serves, or a board on which an appointee of that individual serves, (2) a candidate for the office held by such individual, or (3) a committee controlled by such individual, at any time from the commencement of negotiations for the contract until the later of either the termination of negotiations for such contract or six months after the date the contract is approved. Tenant acknowledges that the foregoing restriction applies only if the contract or a combination or series of contracts approved by the same individual or board in a fiscal year have a total anticipated or actual value of \$50,000 or more. Tenant further acknowledges that the prohibition on contributions applies to each prospective party to the contract; each member of Tenant's board of directors, chairperson, chief executive officer, chief financial officer and chief operating officer; any person with an ownership interest of more than 20 percent in Tenant; any subcontractor listed in the contract; and any committee

that is sponsored or controlled by Tenant. Additionally, Tenant acknowledges that Tenant must inform each of the persons described in the preceding sentence of the prohibitions contained in Section 1.126. Tenant further agrees to provide to City the names of each person, entity or committee described above.

29.32 Sunshine Ordinance

In accordance with Section 67.24(e) of the San Francisco Administrative Code, contracts, contractors' bids, leases, agreements, responses to Requests for Proposals, and all other records of communications between City and persons or firms seeking contracts will be open to inspection immediately after a contract has been awarded. Nothing in this provision requires the disclosure of a private person's or organization's net worth or other proprietary financial data submitted for qualification for a contract, lease, agreement or other benefit until and unless that person or organization is awarded the contract, lease, agreement or benefit. Information provided which is covered by this Section will be made available to the public upon request.

29.33 Sugar-Sweetened Beverage Prohibition

Tenant agrees that it will not sell, provide, or otherwise distribute Sugar-Sweetened Beverages, as defined by San Francisco Administrative Code Chapter 101, as part of its performance of this Agreement.

28.52 Vending Machines; Nutritional Standards

Tenant shall not install or permit any vending machine on the Premises without the prior written consent of the Director of Property. Any permitted vending machine must comply with the food nutritional and calorie labeling requirements set forth in San Francisco Administrative Code Section 4.9-1(c), as may be amended from time to time (the "Nutritional Standards Requirements"). Tenant agrees to incorporate the Nutritional Standards Requirements into any contract for the installation of a vending machine on the Premises or for the supply of food and beverages to that vending machine. Failure to comply with the Nutritional Standards Requirements or to otherwise comply with this Section shall be deemed a material breach of this Lease. Without limiting Landlord's other rights and remedies under this Lease, Landlord shall have the right to require the immediate removal of any vending machine on the Premises that is not permitted or that violates the Nutritional Standards Requirements.

28.53 All-Gender Toilet Facilities

If applicable, Tenant shall comply with San Francisco Administrative Code Section 4.1-3 requiring at least one all-gender toilet facility on each floor of any new building on City-owned land and within existing buildings leased by the City where extensive renovations are made. An "all-gender toilet facility" means a toilet that is not restricted to use by persons of a specific sex or gender identity by means of signage, design, or the installation of fixtures, and "extensive renovations" means any renovation where the construction cost exceeds 50% of the cost of providing the toilet facilities required by this section. If Tenant has any question about applicability or compliance, Tenant should contact the Director of Property for guidance.

29.34 Counterparts

This Lease may be executed in two or more counterparts, each of which shall be deemed an original, but all of which taken together shall constitute one and the same instrument.

29.35 Effective Date

This Lease shall become effective on the date upon which each of the following has occurred: (i) the City's Board of Supervisors and the Mayor have adopted a resolution approving this Lease and (ii) the parties hereto have duly executed this Lease.

29.36 Cooperative Drafting

This Lease has been drafted through a cooperative effort of both parties, and both parties have had an opportunity to have the Lease reviewed and revised by legal counsel. No party shall be considered the drafter of this Lease, and no presumption or rule that an ambiguity shall be construed against the party drafting the clause shall apply to the interpretation or enforcement of this Lease.

NOTWITHSTANDING ANYTHING TO THE CONTRARY CONTAINED IN THIS LEASE, THE PARTIES ACKNOWLEDGE THAT NO OFFICER OR EMPLOYEE OF CITY HAS AUTHORITY TO COMMIT CITY TO THIS LEASE UNLESS AND UNTIL A RESOLUTION OF CITY SHALL HAVE BEEN DULY ADOPTED APPROVING THIS LEASE, AND AUTHORIZING APPROPRIATE CITY OFFICERS TO CARRY OUT THE TRANSACTIONS CONTEMPLATED HEREBY. THEREFORE, ANY OBLIGATIONS OR LIABILITIES OF CITY HEREUNDER ARE CONTINGENT UPON, AND SUBJECT TO, DUE ADOPTION OF SUCH A RESOLUTION, AND THIS LEASE SHALL BE NULL AND VOID IF SUCH RESOLUTION IS NOT ADOPTED BY THE BOARD OF SUPERVISORS AND APPROVED BY THE MAYOR, IN THEIR RESPECTIVE SOLE AND ABSOLUTE DISCRETION, AND IN ACCORDANCE WITH CITY'S CHARTER AND ALL OTHER APPLICABLE LAWS. APPROVAL OF THE TRANSACTIONS CONTEMPLATED BY THIS LEASE BY ANY DEPARTMENT, COMMISSION OR AGENCY OF CITY SHALL NOT BE DEEMED TO IMPLY THAT SUCH RESOLUTION WILL BE ADOPTED NOR WILL ANY SUCH APPROVAL CREATE ANY BINDING OBLIGATIONS ON CITY.

[REMAINDER OF PAGE INTENTIONALLY BLANK]

City and Tenant have executed this Lease as of the date first written above.

TENANT:

T-MOBILE WEST LLC,
a Delaware limited liability company

By:  _____

Its: David Gallacher
VP, West Region Engineering 

By: _____

Its: _____

CITY:

CITY AND COUNTY OF SAN FRANCISCO,
a municipal corporation

By: _____
JOHN UPDIKE
Director of Property

APPROVED AS TO FORM:

DENNIS J. HERRERA
City Attorney

By: _____
Carol Wong
Deputy City Attorney

City's Condition of Signature

City's Director of Property will only execute this lease at such time as tenant has provided written confirmation that it will either a). use municipal power provided by the San Francisco Public Utilities Commission; or b). the San Francisco Public Utilities Commission determines that providing power to this site is not practical or feasible.

EXHIBIT A
PLANS

Schedule of Access Areas Not Depicted in The Site Plans

Listed below are areas of the subject property that Tenant's equipment, cabling, utilities, and/or areas that Tenant will require access to during construction and operation.

1. The roof
2. The freight elevator
3. The North Electrical Penthouse on the roof for our electrical
4. The North Mechanical Penthouse, where our equipment will be located
5. Parking spots in parking garage
6. Crane pick off of side street—location and time of use to be mutually agreed on as need dictates—

T-Mobile

WEST REGION
1855 GATEWAY BLVD, SUITE 900
CONCORD, CA 94520

SF70359A - BANK OF AMERICA

NSB PROJECT
1525 MARKET ST
SAN FRANCISCO, CA 94103



1855 GATEWAY BLVD, SUITE 900
CONCORD, CA 94520

PRECISION DESIGN
Drafting, INC.
Phone: (925) 232-2666
11788 Avenida del Sur, Suite 20, Dublin, CA 94568



BANK OF AMERICA

SF70359A
1525 MARKET ST
SAN FRANCISCO, CA 94103

ISSUE STATUS

DATE	DESCRIPTION
04/19/13	20 100%
05/29/13	20 100%
07/29/13	CD 100%
07/11/13	CD 100%
08/14/13	CD 100%
08/24/13	CD 100%

DRAWN BY: F. CASTILLO
CHECKED BY: B. McCOMB
APPROVED BY: B. McCOMB
DATE: 08/01/13

TITLE SHEET

SHEET NUMBER

T-1

PROJECT DESCRIPTION

A 99 UNIMOUNTED TELECOMMUNICATION FACILITY CONSISTING OF A 99 LOCK AREA, 19 99 EQUIPMENT & A 99 STRUCTURE TO MOUNT ANTENNAS BY 99 ANTENNAS.

- INSTALL 09 99 ANTENNAS
- INSTALL 09 99 99 99 CHASIS
- INSTALL 09 99 99 99 99 99 99 99
- INSTALL 09 99 99 99 99 99 99 99
- INSTALL 09 99 99 99 99 99 99 99
- INSTALL 09 99 99 99 99 99 99 99
- INSTALL 09 99 99 99 99 99 99 99
- INSTALL 09 99 99 99 99 99 99 99
- INSTALL 09 99 99 99 99 99 99 99
- INSTALL 09 99 99 99 99 99 99 99
- INSTALL 09 99 99 99 99 99 99 99
- INSTALL 09 99 99 99 99 99 99 99

PROJECT INFORMATION

SITE NAME:	BANK OF AMERICA	SITE #:	SF70359A
SITE TYPE:	NSB	JURISDICTION:	CITY & COUNTY OF SAN FRANCISCO
COUNTY:	SAN FRANCISCO	FORMER:	PG&E
APN:	350C-001	TELEPHONE:	ACT
SITE ADDRESS:	1525 MARKET ST SAN FRANCISCO, CA 94103		
CURRENT ZONING:	C-5A		
CONSTRUCTION TYPE:	-		
OCCUPANCY TYPE:	-		
PROPERTY OWNER:	CITY AND COUNTY OF SAN FRANCISCO REAL ESTATE DIVISION 25 VAN NESS AVE., SUITE 400 SAN FRANCISCO, CA 94102 JOSHUA.KENNEDY@SFONLINE.ORG (415) 554-8889		
APPLICANT:	T-MOBILE 1855 GATEWAY BLVD., SUITE 900 CONCORD, CA 94520		
LEASING CONTACT:	AT&T MOBILE SERVICE MCCLOSKEY INC. 8025 3602-8920		
ZONING CONTACT:	AT&T MOBILE SERVICE MCCLOSKEY INC. 4008 219-5442 TMOBILE@MCCLOSKEY-CORP.COM		
CONSTRUCTION CONTACT:	AT&T MOBILE SERVICE MCCLOSKEY INC. 8025 3602-8920		
LOCATION:	37°42'57" N 122°29'07" W		
COORDINATES:	122°29'07" W @ 122.410889 W @ 83		
ANGL:	±51°		

VICINITY MAP



DRIVING DIRECTIONS

FROM: 1855 GATEWAY BLVD, SUITE 900, CONCORD, CA 94520
TO: 1525 MARKET ST, SAN FRANCISCO, CA 94103

- WENT SOUTHBOUND ON GATEWAY BLVD 177 FT
- TURN RIGHT ONTO CLAYTON RD 0.2 MI
- TAKE THE RAMP ONTO CA-242 S 0.3 MI
- MERGE ONTO CA-242 S 0.9 MI
- MERGE ONTO I-680 S 3.3 MI
- TAKE EXIT 46 FOR CALIFORNIA 24 TOWARD LAFFETTES/REDLAND 1.2 MI
- COMBINE ONTO CA-24 W 5.8 MI
- KEEP LEFT TO STAY ON CA-24 W 2.3 MI
- KEEP LEFT AT THE FORK TO STAY ON CA-24 W 4.3 MI
- TAKE EXIT 20 FOR INTERSTATE 500 W 1.0 MI
- MERGE ONTO I-580 W 0.6 MI
- TAKE EXIT 134 ON THE LEFT TO MERGE ONTO I-580 W TOWARD SAN FRANCISCO 0.3 MI
- TAKE EXIT 10 TO MERGE ONTO US-101 N TOWARD GOLDEN GATE BRIDGE 0.7 MI
- TAKE EXIT 484A FOR U.S. 101 N TOWARD SPRECKELSBOURGE AVENUE TOWARD G & BRIDGE 0.2 MI
- SUSPECT RIGHT TOWARD MESSON ST (EXIT FOR US-101 N TOWARD MESSON 39 VAN NESS AVENUE & BRIDGE) 210 FT
- COMBINE ONTO MESSON ST 0.1 MI
- SUSPECT LEFT ONTO 5 VAN NESS AVE 0.2 MI
- TURN RIGHT AT THE 1ST CROSS STREET ONTO MARKET ST 55 FT

END AT: 1525 MARKET ST, SAN FRANCISCO, CA 94103
ESTIMATED TRAVEL TIME: 30 MIN ESTIMATED DISTANCE: 23.4 MI

CODE COMPLIANCE

ALL WORK & MATERIALS SHALL BE PERFORMED & INSTALLED IN ACCORDANCE WITH THE CURRENT EDITIONS OF THE FOLLOWING CODES AS ADOPTED BY THE LOCAL GOVERNING AUTHORITIES. NOTHING IN THESE PLANS IS TO BE CONSTRUED TO PERMIT WORK NOT CONFORMING TO THESE CODES.

- 2013 CALIFORNIA ADMINISTRATIVE CODE (MCL, TITLES 24 & 25)
- 2013 CALIFORNIA BUILDING CODE
- 2013 CALIFORNIA ELECTRICAL CODE
- 2013 CALIFORNIA MECHANICAL CODE
- 2013 CALIFORNIA PLUMBING CODE
- 2013 CALIFORNIA FIRE CODE
- LOCAL BUILDING CODES
- CITY/COUNTY ORDINANCES
- AMSDA-TA-222-G

ALONG WITH ANY OTHER APPLICABLE LOCAL & STATE LAWS AND REGULATIONS

HANDICAP REQUIREMENTS

THIS FACILITY IS UNIMOUNTED & NOT FOR PLANNING INFRASTRUCTURE. HANDICAPPED ACCESS & REQUIREMENTS ARE NOT REQUIRED IN ACCORDANCE WITH CALIFORNIA STATE ADMINISTRATIVE CODE, TITLE 24 PART 2, SECTION 11050.5.4.2, DECEPTION 1

SHEET INDEX

SHEET	DESCRIPTION	REV
T-1	TITLE SHEET	-
T-2	FIRE DEPARTMENT CHECKLIST	-
T-3	RF EXPOSURE	-
T-4	RF SIGNAGE	-
A-1	OVERALL SITE PLAN	-
A-2	SITE PLAN	-
A-3	EQUIPMENT PLAN	-
A-4	ANTENNA PLANS & DETAILS	-
A-5	ELEVATIONS	-
A-6	ELEVATIONS	-
A-7	ELEVATIONS	-
A-8	ELEVATIONS	-
A-9	DETAILS	-
A-10	DETAILS	-
P-1	PHOTO SIMULATION	-
S-1	FRP SCREEN PLAN	-
S-2	FRP SCREEN DETAILS	-
E-1	ELECTRICAL PLAN	-
E-2	GROUNDING PLAN	-
E-3	GROUNDING DETAILS	-

APPROVAL

RF

LEASING

CONSTRUCTION

T-MOBILE

PG&E

FIRE DEPARTMENT CHECKLIST

2.06 Submittal Requirements for Cellular Antenna Sites

REFERENCE: 2013 SMC, 2013 SMC, 2013 SMC and FCC OET Bulletin 65 (97-01)

1. Provide a description of work on the plan.

2. Plans shall include floor plans and elevations showing all equipment locations and cable runs.

3. Plans shall include antenna cut-sheets and equipment list on a drawing sheet.

4. Include a copy of the report and example RF report on a drawing sheet as a reference to identify the antenna area required to prevent occupational exposures in excess of the FCC guidelines (47CFR 1.1310 and FCC OET Bulletin 65 edition 97-01).

5. The RF report shall indicate whether or not the site under review is a part of a multiple transmitter site and shall show compliance with FCC 47CFR 1.1307(b)(2), as amended - if transmitters shall not exceed 5% of the power density exposure limit.

6. Drawings shall reflect the step-downs areas for workers per the above RF Report with a minimum radius of 1 foot.

7. Plans shall include a questionnaire three-dimensional map of the RF levels from each antenna located near an exposed point (e.g. posthole stem, fire escape, roof walking paths, skylights, etc.).

8. "Notice to Workers" warning signage, as applicable per the above RF Report, shall be permanently mounted at the standard site of the roof-access door (NFPA 704 C95.2.1.5B2 guidance [D] - yellow or more drastic color for outdoor ladders).

9. Caricatured antennas shall have a clear signage permanently mounted to the exterior of the RF screen as provided below. The sign shall be weatherproof with contrasting background color and shall contain the yellow triangle around the antenna symbol (NFPA 704 C95.2.1.5B2 Guidance [D] - yellow or more drastic color for outdoor ladders). Signage background and detail of the sign shall be included on the plan.

10. Color-coding shall not be allowed in one enclosure, single-point towers, elevator shafts, or in front of dry standpipes, 2013 CFC 1022.4 and 509.2

11. Antennas shall not be mounted closer than the antenna zone plus 4 feet for walkways near fire escapes, stair postholes doors, outdoor skylights, skylights, or other fire department operators consideration.

12. There is no guarantee that the fire department will not shut down the power to the site in an emergency situation although in order to reduce the site operator's possible loss of service the following information may be provided at the equipment from entrance:

• Provide emergency shutdown procedures signage. The sign shall include the following:

- 1. Emergency 24 hour/7 day a week NOC/field technician telephone number for RF site-down
 - 2. Call site identification number
 - 3. Map to location of electrical room - electrical room shall be clearly identified with a permanent red label and white lettering.
 - 4. Map to location of battery cabinets and breakers - cabinets and breakers shall be clearly identified with a permanent red label and white lettering.
 - 5. Any other relevant information or procedures as required for the individual cellular site.
- The sign shall be clearly labeled in a periodic label with a white background and black lettering. The label shall be a red background and 1" high white lettering. Multiple signs may need to be installed based upon the cellular site configuration. A copy of the signage shall be included on a drawing sheet. See attached sample.

PROVIDED, SEE SHEET 14

PROVIDED, SEE SHEET 14

PROVIDED, SEE SHEET 14

PROVIDED, SEE SHEET 14

PROVIDED, SEE SHEET 14

PROVIDED, SEE SHEET 14

PROVIDED, SEE SHEET 14

PROVIDED, SEE SHEET 14

PROVIDED, SEE SHEET 14

PROVIDED, SEE SHEET 14



PRECISION DESIGN
Drafting, INC.
 Phone: (530) 823-8548
 11788 Alwood Rd Suite 20 Auburn, CA 95603

T-Mobile
 WEST REGION
 1855 GATEWAY BLVD, SUITE 800
 CONCORD, CA 94520

BANK OF AMERICA

57703554
 1825 WALTER ST
 SAN FRANCISCO, CA 94109

SCALE STATUS

DATE	DESCRIPTION
08/17/13	20 50%
08/28/13	80 100%
09/03/13	80 100%
09/03/13	80 100%
09/03/13	80 100%
09/03/13	80 100%

DESIGNED BY: J. JOHNSON
 CHECKED BY: B. MCDONALD
 APPROVED BY: B. MCDONALD
 DATE: 08/28/13
 SHEET NO: 14
 SHEET TOTAL: 14

FIRE DEPARTMENT CHECKLIST

T-2

PROJECT GENERAL NOTES

1. THE PROJECT IS AN UNCORRECTED SURVEY SUBSTANTIATION PROJECT.
2. THIS PLAN IS TO BE USED FOR THE PURPOSES OF THE PROJECT AND IS NOT TO BE USED FOR ANY OTHER PURPOSES.
3. THE OWNER SHALL MAINTAIN NEIGHBORING LOT/LANDS, EASEMENTS, AND RIGHTS RESERVED TO COMPLETE ALL REQUIREMENTS OF THE PROJECT.
4. THE CONTRACTOR SHALL VERIFY THE EXISTING CONDITIONS AND RECORD THEM TO THE PROJECT RECORD DRAWINGS. THE CONTRACTOR SHALL VERIFY THE EXISTING CONDITIONS AND RECORD THEM TO THE PROJECT RECORD DRAWINGS. THE CONTRACTOR SHALL VERIFY THE EXISTING CONDITIONS AND RECORD THEM TO THE PROJECT RECORD DRAWINGS.
5. IF THE CONTRACTOR OF THE PROJECT IS NOT THE RECORD DRAWING CONTRACTOR, THE CONTRACTOR SHALL VERIFY THE EXISTING CONDITIONS AND RECORD THEM TO THE PROJECT RECORD DRAWINGS.
6. THE CONTRACTOR SHALL VERIFY THE EXISTING CONDITIONS AND RECORD THEM TO THE PROJECT RECORD DRAWINGS.
7. THE CONTRACTOR SHALL VERIFY THE EXISTING CONDITIONS AND RECORD THEM TO THE PROJECT RECORD DRAWINGS.
8. THE CONTRACTOR SHALL VERIFY THE EXISTING CONDITIONS AND RECORD THEM TO THE PROJECT RECORD DRAWINGS.
9. THE CONTRACTOR SHALL VERIFY THE EXISTING CONDITIONS AND RECORD THEM TO THE PROJECT RECORD DRAWINGS.
10. THE CONTRACTOR SHALL VERIFY THE EXISTING CONDITIONS AND RECORD THEM TO THE PROJECT RECORD DRAWINGS.
11. THE CONTRACTOR SHALL VERIFY THE EXISTING CONDITIONS AND RECORD THEM TO THE PROJECT RECORD DRAWINGS.
12. THE CONTRACTOR SHALL VERIFY THE EXISTING CONDITIONS AND RECORD THEM TO THE PROJECT RECORD DRAWINGS.
13. THE CONTRACTOR SHALL VERIFY THE EXISTING CONDITIONS AND RECORD THEM TO THE PROJECT RECORD DRAWINGS.
14. THE CONTRACTOR SHALL VERIFY THE EXISTING CONDITIONS AND RECORD THEM TO THE PROJECT RECORD DRAWINGS.
15. THE CONTRACTOR SHALL VERIFY THE EXISTING CONDITIONS AND RECORD THEM TO THE PROJECT RECORD DRAWINGS.
16. THE CONTRACTOR SHALL VERIFY THE EXISTING CONDITIONS AND RECORD THEM TO THE PROJECT RECORD DRAWINGS.
17. THE CONTRACTOR SHALL VERIFY THE EXISTING CONDITIONS AND RECORD THEM TO THE PROJECT RECORD DRAWINGS.

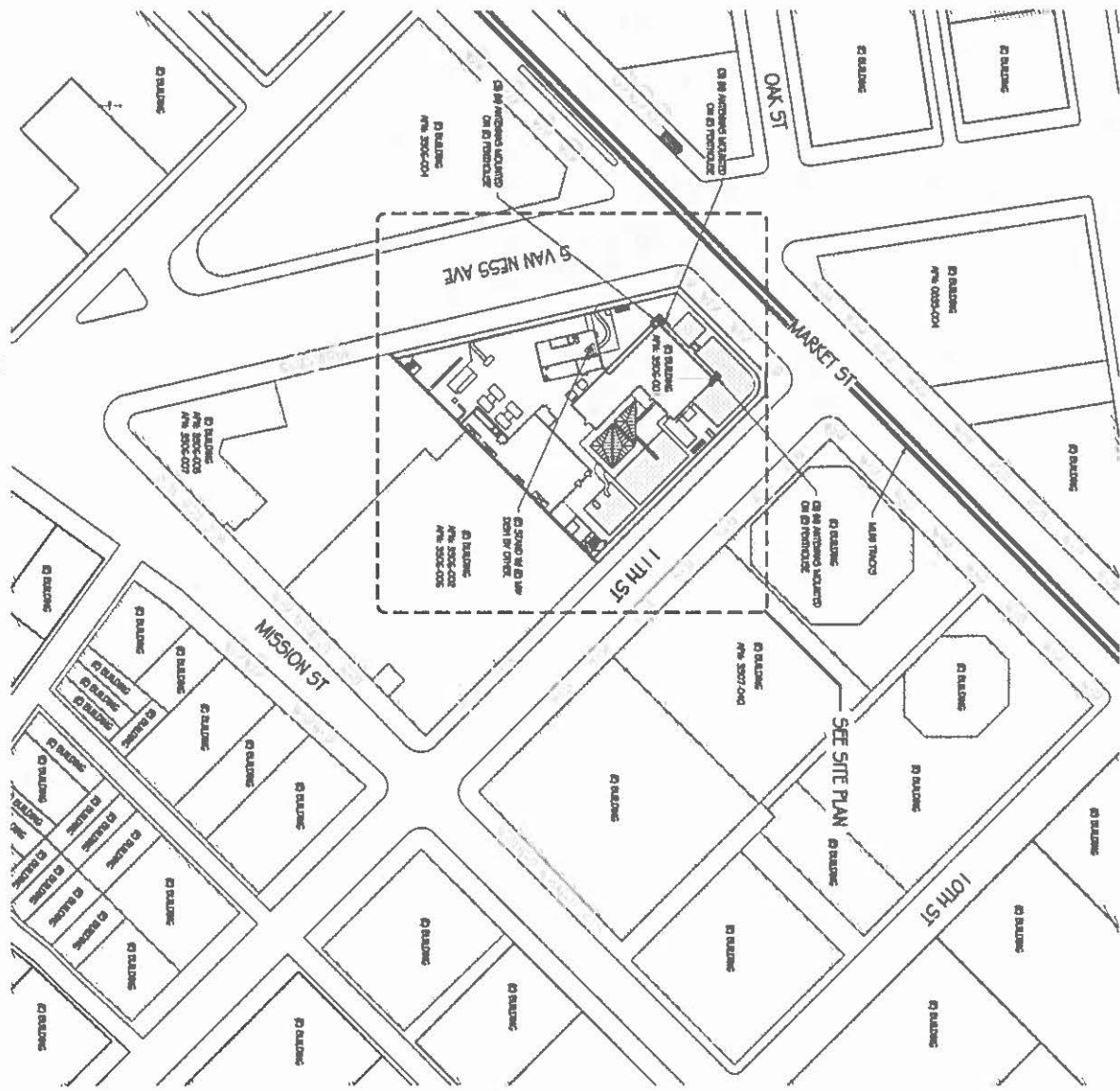

OVERALL SITE PLAN

T-Mobile
 WEST REGION
 1855 GATWAY BLVD, SUITE 900
 CONCORD, CA 94530

PRECISION DESIGN
Drafting, Inc.
 Phone: (925) 823-8548
 11786 Alwood Rd., Suite 20 Albany, CA 95013



BANK OF AMERICA
 97703594
 1525 MARKET ST
 SAN FRANCISCO, CA 94103

SHEET STATUS	
DATE	DESCRIPTION
08/11/15	01 50%
08/27/15	02 100%
09/01/15	03 100%
09/01/15	04 100%
09/01/15	05 100%
09/01/15	06 100%
09/01/15	07 100%
09/01/15	08 100%
09/01/15	09 100%
09/01/15	10 100%
09/01/15	11 100%
09/01/15	12 100%
09/01/15	13 100%
09/01/15	14 100%
09/01/15	15 100%
09/01/15	16 100%
09/01/15	17 100%
09/01/15	18 100%
09/01/15	19 100%
09/01/15	20 100%
09/01/15	21 100%
09/01/15	22 100%
09/01/15	23 100%
09/01/15	24 100%
09/01/15	25 100%
09/01/15	26 100%
09/01/15	27 100%
09/01/15	28 100%
09/01/15	29 100%
09/01/15	30 100%
09/01/15	31 100%
09/01/15	32 100%
09/01/15	33 100%
09/01/15	34 100%
09/01/15	35 100%
09/01/15	36 100%
09/01/15	37 100%
09/01/15	38 100%
09/01/15	39 100%
09/01/15	40 100%
09/01/15	41 100%
09/01/15	42 100%
09/01/15	43 100%
09/01/15	44 100%
09/01/15	45 100%
09/01/15	46 100%
09/01/15	47 100%
09/01/15	48 100%
09/01/15	49 100%
09/01/15	50 100%
09/01/15	51 100%
09/01/15	52 100%
09/01/15	53 100%
09/01/15	54 100%
09/01/15	55 100%
09/01/15	56 100%
09/01/15	57 100%
09/01/15	58 100%
09/01/15	59 100%
09/01/15	60 100%
09/01/15	61 100%
09/01/15	62 100%
09/01/15	63 100%
09/01/15	64 100%
09/01/15	65 100%
09/01/15	66 100%
09/01/15	67 100%
09/01/15	68 100%
09/01/15	69 100%
09/01/15	70 100%
09/01/15	71 100%
09/01/15	72 100%
09/01/15	73 100%
09/01/15	74 100%
09/01/15	75 100%
09/01/15	76 100%
09/01/15	77 100%
09/01/15	78 100%
09/01/15	79 100%
09/01/15	80 100%
09/01/15	81 100%
09/01/15	82 100%
09/01/15	83 100%
09/01/15	84 100%
09/01/15	85 100%
09/01/15	86 100%
09/01/15	87 100%
09/01/15	88 100%
09/01/15	89 100%
09/01/15	90 100%
09/01/15	91 100%
09/01/15	92 100%
09/01/15	93 100%
09/01/15	94 100%
09/01/15	95 100%
09/01/15	96 100%
09/01/15	97 100%
09/01/15	98 100%
09/01/15	99 100%
09/01/15	100 100%

OVERALL SITE PLAN
 SHEET STATUS
A-1

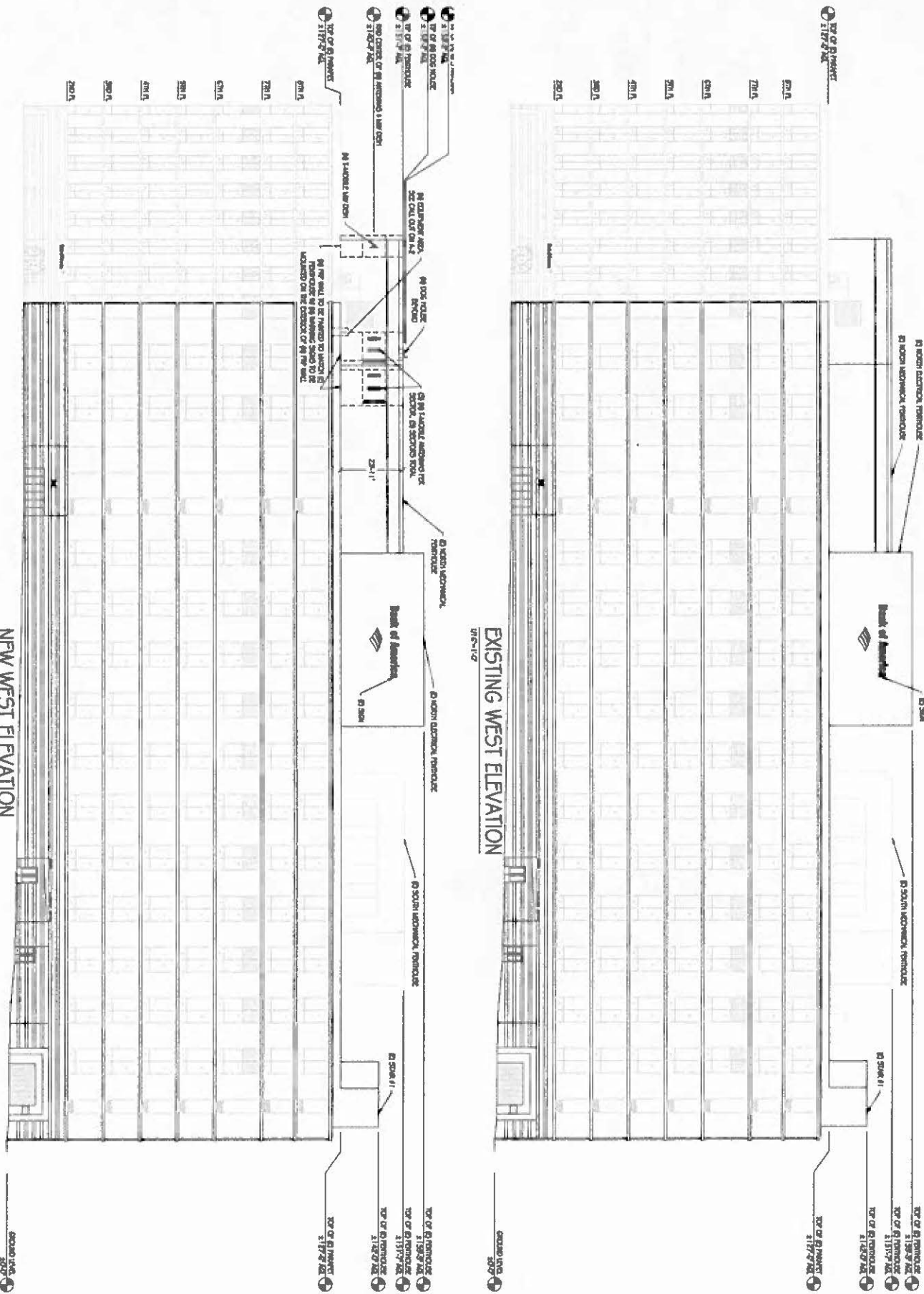

EXISTING WEST ELEVATION
1/25-1/27

NEW WEST ELEVATION
1/25-1/27

08/20/2006
2007

PRECISION DESIGN
Drafting, Inc.
Phone: (530) 823-8546
11788 Alwood Rd, Suite 20 Auburn, CA 95603



BANK OF AMERICA
5770359A
1325 MARKET ST
SAN FRANCISCO, CA 94103

ISSUE STATUS

DATE	DESCRIPTION
08/20/06	ISSUED FOR PERMIT
08/20/06	ISSUED FOR PERMIT
08/20/06	ISSUED FOR PERMIT
08/20/06	ISSUED FOR PERMIT
08/20/06	ISSUED FOR PERMIT
08/20/06	ISSUED FOR PERMIT
08/20/06	ISSUED FOR PERMIT
08/20/06	ISSUED FOR PERMIT
08/20/06	ISSUED FOR PERMIT
08/20/06	ISSUED FOR PERMIT

APPROVED BY: S. M. M. M. M.
DATE: 08/20/06
SHEET TITLE: ELEVATIONS
PROJECT NUMBER: A-5

T-Mobile
WEST REGION
1823 GATEWAY BLVD, SUITE 900
CONCORD, CA 94520

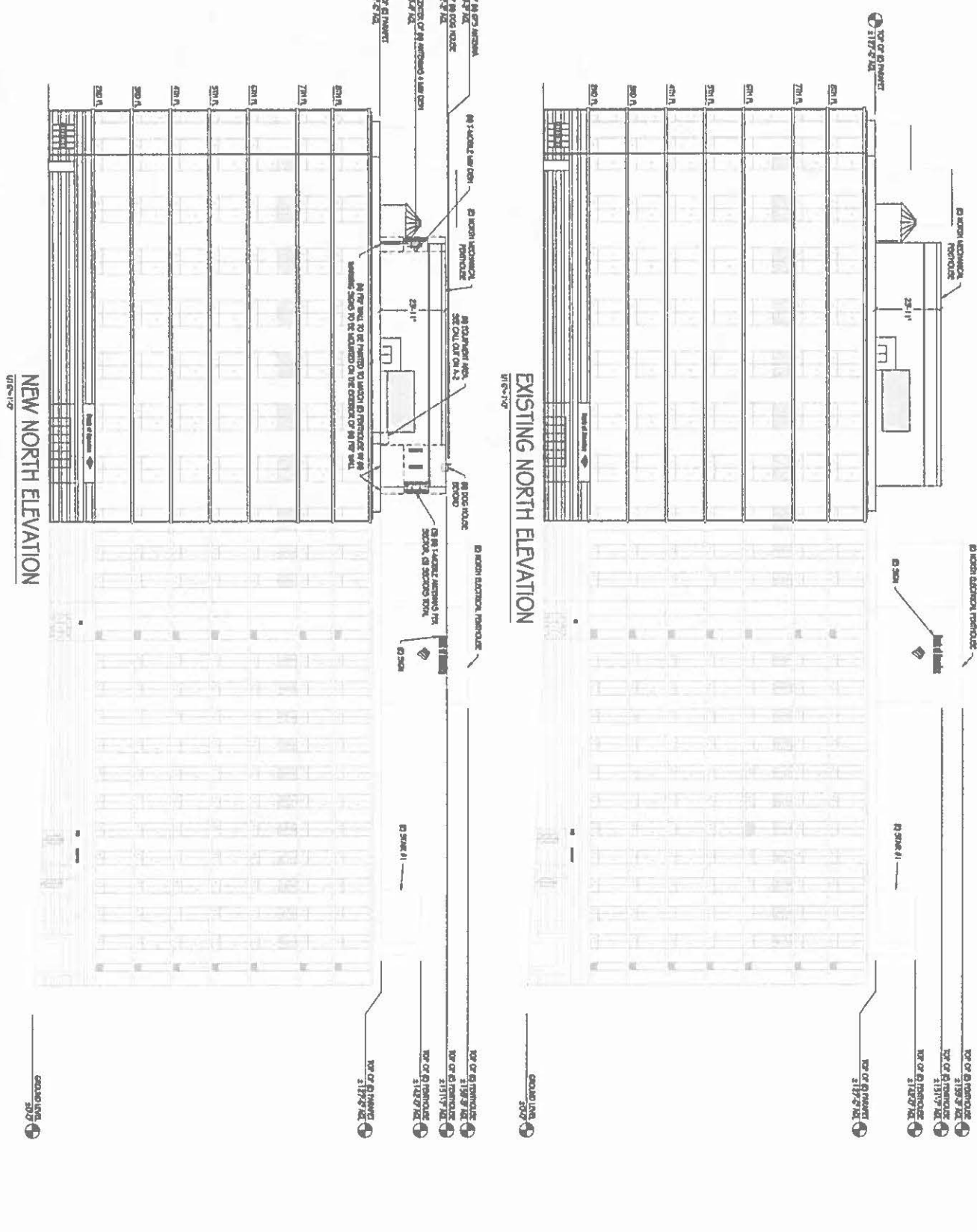

NEW NORTH ELEVATION
1/18/17

EXISTING NORTH ELEVATION
1/18/17

<p>PRECISION DESIGN <i>Drafting, Inc.</i> Phone: (530) 823-8548 11788 Alwood Rd, Suite 20 Auburn, CA 95603</p>		<p>T-Mobile WEST REGION 1828 DARTMOUTH BLVD, SUITE 200 CONCORD, CA 94520</p>																	
<p>BANK OF AMERICA 57703594 1525 MARKET ST SAN FRANCISCO, CA 94103</p>																			
<p>1594.E STATUS</p> <table border="1"> <thead> <tr> <th>DATE</th> <th>DESCRIPTION</th> </tr> </thead> <tbody> <tr> <td>01/17/17</td> <td>01 100% CD 100%</td> </tr> <tr> <td>01/17/17</td> <td>01 100% CD 100%</td> </tr> <tr> <td>07/20/15</td> <td>01 100% CD 100%</td> </tr> <tr> <td>07/20/15</td> <td>01 100% CD 100%</td> </tr> <tr> <td>05/03/15</td> <td>01 100% CD 100%</td> </tr> <tr> <td>05/03/15</td> <td>01 100% CD 100%</td> </tr> <tr> <td>01/17/17</td> <td>01 100% CD 100%</td> </tr> </tbody> </table> <p>Drawn by: F. Orosz Checked by: B. McQuinn Approved by: B. McQuinn Date: 02/04/17 Sheet Title: ELEVATIONS</p>				DATE	DESCRIPTION	01/17/17	01 100% CD 100%	01/17/17	01 100% CD 100%	07/20/15	01 100% CD 100%	07/20/15	01 100% CD 100%	05/03/15	01 100% CD 100%	05/03/15	01 100% CD 100%	01/17/17	01 100% CD 100%
DATE	DESCRIPTION																		
01/17/17	01 100% CD 100%																		
01/17/17	01 100% CD 100%																		
07/20/15	01 100% CD 100%																		
07/20/15	01 100% CD 100%																		
05/03/15	01 100% CD 100%																		
05/03/15	01 100% CD 100%																		
01/17/17	01 100% CD 100%																		
<p>A-6</p>																			

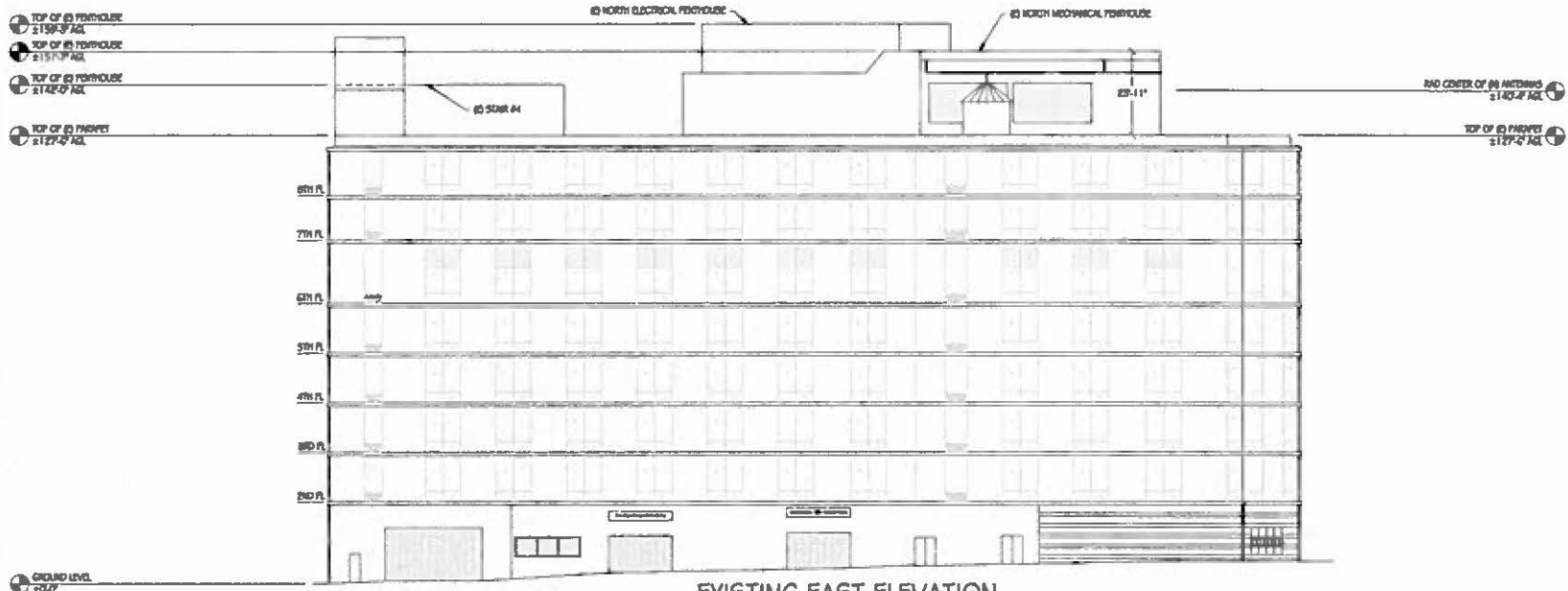

EXISTING EAST ELEVATION
1/16" = 1'-0"

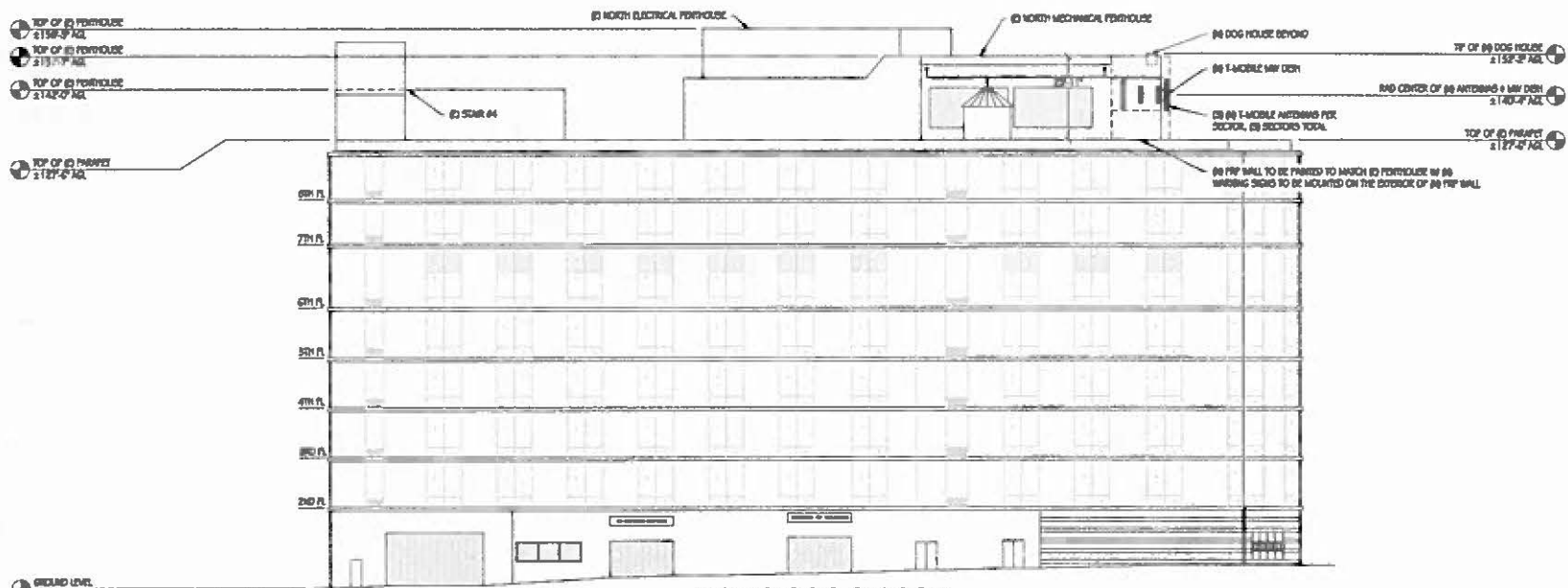

NEW EAST ELEVATION
1/16" = 1'-0"

T-Mobile
 1845 GATEWAY BLVD., SUITE 800
 COMMERCE, CA 91702

PRECISION DESIGN
Drafting, Inc.
 Phone (832) 637-0444
 11788 Alameda Rd., Suite 22, Auburn, CA 95603



BANK OF AMERICA
 SF70359A
 1525 MARKET ST
 SAN FRANCISCO, CA 94108

ISSUE STATUS

DATE	DESCRIPTION
04/19/15	2D 50%
06/23/15	2D 100%
07/08/15	CD 30%
07/28/15	CD 100%
08/17/16	CD 100%
08/24/16	CD 100%

DRAWN BY: T. CHESTAD
 CHECKED BY: B. MACDON
 APPROVED BY: B. MACDON
 DATE: 08/24/16

SHEET TITLE:
 ELEVATIONS
 SHEET NUMBER:
A-7

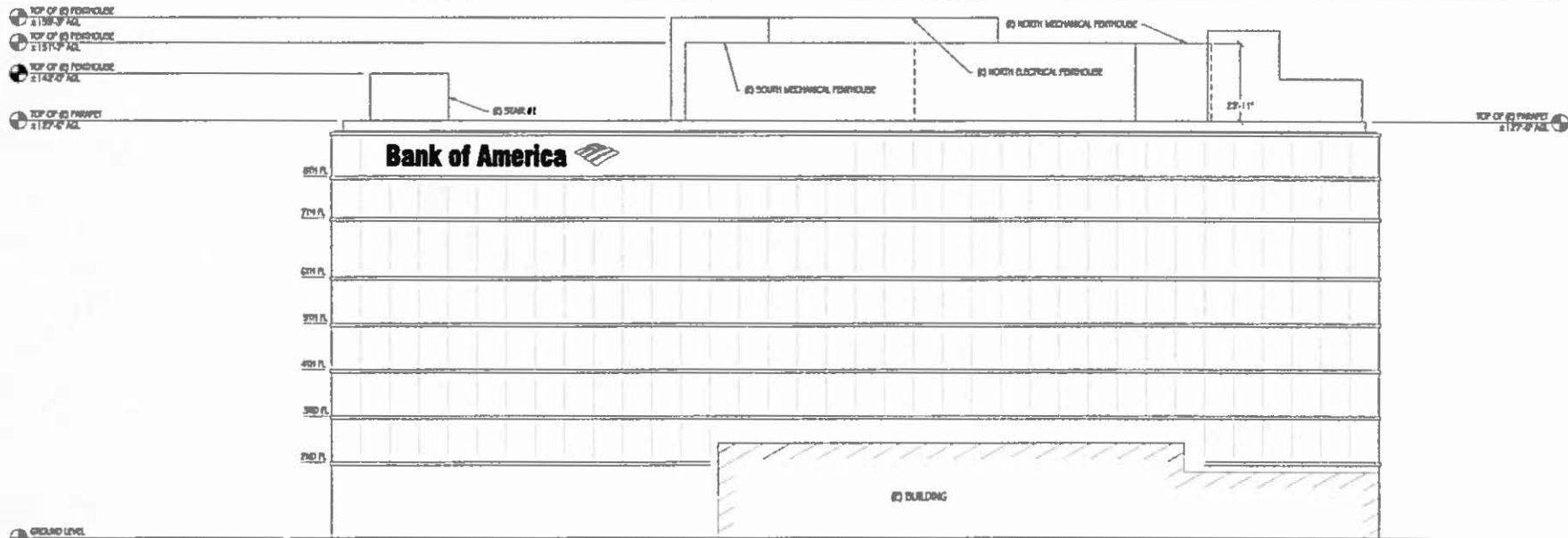

EXISTING SOUTH ELEVATION
1/16"=1'-0"

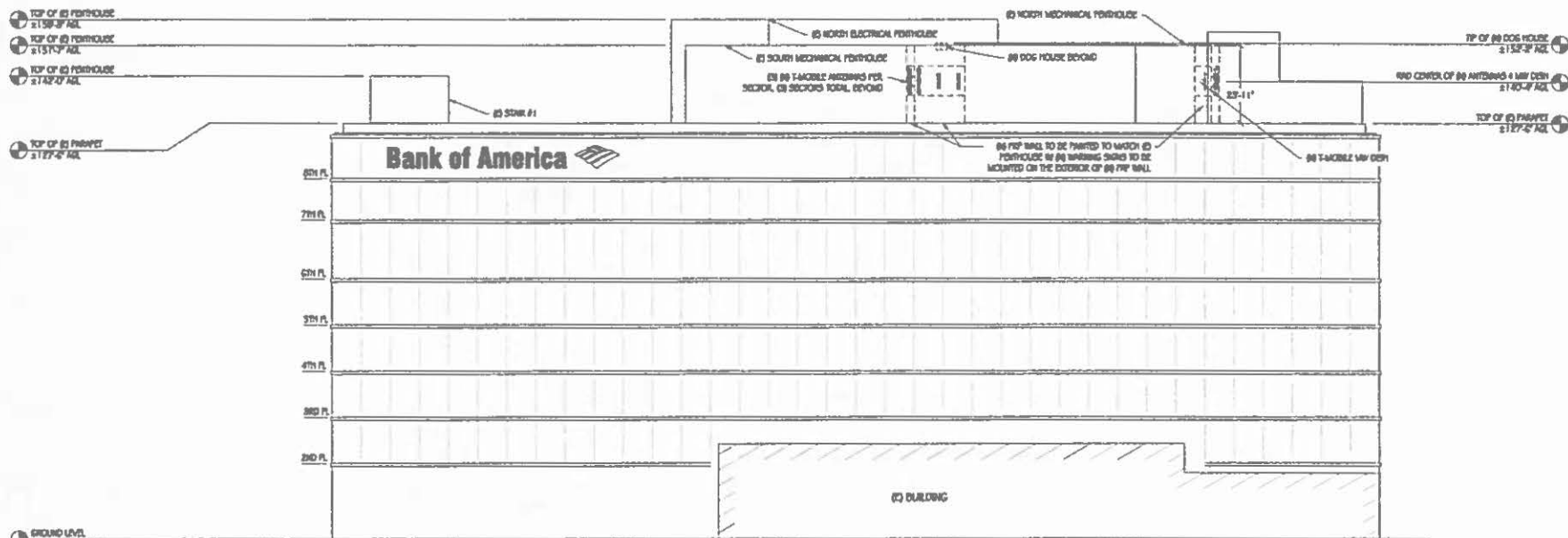

NEW SOUTH ELEVATION
1/16"=1'-0"



PRECISION DESIGN
Drafting, Inc.
Phone (320) 823-8848
11764 Avenida Pk, Suite 20 Auburn, CA 95603



BANK OF AMERICA
SF70359A
1525 MARKET ST
SAN FRANCISCO, CA 94108

ISSUE STATUS

DATE	DESCRIPTION
04/15/15	3D 50%
06/29/15	3D 100%
07/08/15	CD 50%
07/28/15	CD 100%
08/01/16	CD 100% CL
08/24/16	CD 100% CL

DESIGN BY: F. CASTELLA
CHECKED BY: S. MCCOMB
APPROVED BY: S. MCCOMB
DATE: 08/24/16
SHEET FILE:

ELEVATIONS
SHEET NUMBER
A-8

PROJECT GENERAL NOTES

1. THIS FACILITY IS AN UNOCCUPIED WIRELESS TELECOMMUNICATION FACILITY.
2. PLANS ARE NOT TO BE SCALED AND ARE INTENDED TO BE A DIMENSIONAL GUIDE ONLY UNLESS NOTED OTHERWISE.
3. THE SCOPE OF WORK SHALL INCLUDE FURNISHING MATERIALS, EQUIPMENT, APPLIANCES AND LABOR NECESSARY TO COMPLETE ALL INSTALLATIONS AS SPECIFIED ON THE DRAWINGS.
4. PRIOR TO THE SUBMISSION OF BIDS, THE CONTRACTORS SHALL VISIT THE JOB SITE AND BE RESPONSIBLE FOR ALL CONTRACT DOCUMENTS, FIELD CONDITIONS AND DIMENSIONS, AND CONFIRM THAT THE WORK MAY BE ACCOMPLISHED AS SHOWN PRIOR TO PROCEEDING WITH CONSTRUCTION. ANY DISCREPANCIES ARE TO BE BROUGHT TO THE ATTENTION OF THE CONSTRUCTION MANAGER AND ENGINEER PRIOR TO PROCEEDING WITH THE WORK.
5. IT IS THE RESPONSIBILITY OF THE CONTRACTOR TO PAY FOR PERMIT FEES AND TO OBTAIN SAID PERMITS AND TO COORDINATE REVISIONS.
6. THE CONTRACTOR SHALL RECEIVE, IN WRITING, AUTHORIZATION TO PROCEED BEFORE STARTING WORK ON ANY ITEM NOT CLEARLY DEFINED OR DESCRIBED BY THE CONTRACT DOCUMENTS.
7. ALL WORK PERFORMED AND MATERIALS INSTALLED SHALL BE IN STRICT ACCORDANCE WITH ALL APPLICABLE CODES, REGULATIONS, AND ORDINANCES. CONTRACTOR SHALL GIVE ALL NOTICES AND COMPLY WITH ALL LAWS, ORDINANCES, RULES, REGULATIONS AND LEGAL ORDERS OF ANY PUBLIC AGENCY REGARDING THE PERFORMANCE OF THE WORK.
8. THE GENERAL CONTRACTOR SHALL SUPERVISE AND DIRECT THE WORK USING THE BEST SKILLS AND ATTENTION. THE CONTRACTOR SHALL BE SOLELY RESPONSIBLE FOR ALL CONSTRUCTION MEANS, METHODS, TECHNIQUES, SEQUENCES AND PROCEDURES. CONTRACTOR SHALL ALSO COORDINATE ALL PORTIONS OF THE WORK UNDER THE CONTRACT, INCLUDING CONTACT AND COORDINATION WITH THE CONSTRUCTION MANAGER AND WITH THE LANDLORD'S AUTHORIZED REPRESENTATIVE.
9. THE CONTRACTOR SHALL MAKE NECESSARY PROVISIONS TO PREVENT EXISTING IMPROVEMENTS, FINISH, CURBS, GALVANIZED SURFACES, ETC., AND UPON COMPLETION OF WORK, REPAIR ANY DAMAGE THAT OCCURRED DURING CONSTRUCTION TO THE SATISFACTION OF THE PROJECT MANAGER.
10. KEEP GENERAL AREA CLEAN, TRIMED, FREE, AND REMOVE ALL DIRT, DEBRIS, RUBBISH AND REMOVE EQUIPMENT NOT SPECIFIED AS REMAINING ON THE PROPERTY, LEAVE PREMISES IN CLEAN CONDITION AND FREE FROM PAINT SPILLS, OILS, OR SUBSTANCES OF ANY NATURE.
11. DETAILS ARE INTENDED TO SHOW END RESULT OF DESIGN. MINOR MODIFICATIONS MAY BE REQUIRED TO SUIT JOB DIMENSIONS OR CONDITIONS, AND SUCH MODIFICATIONS SHALL BE INCLUDED AS PART OF THE WORK.
12. CONTRACTOR TO VERIFY THE LARGESOURCEMENT BY DESIGN.

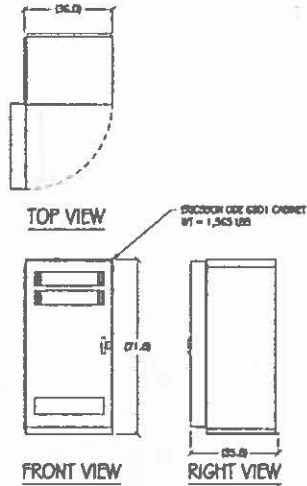

1 ODE 6201 CABINET DETAIL
1/2" = 1'

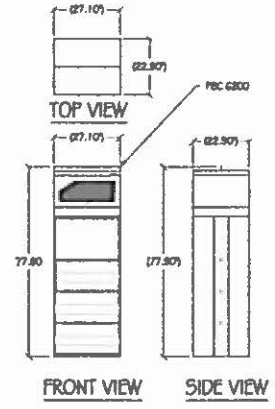

2 PBC 6200 DETAIL
1/2" = 1'

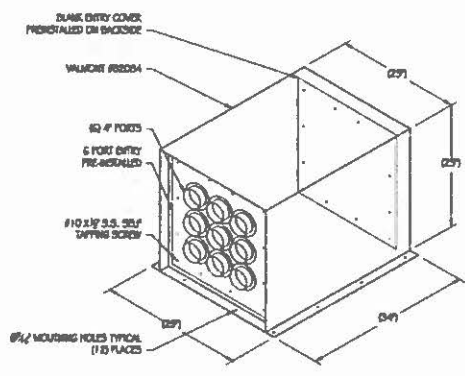

3 DOGHOUSE DETAIL
1" = 1'

ERICSSON RRUS11 B12

COLOR: WHITE
FORM BODY: 44-50 LB (INCLUDING FRAMING)
DIMENSIONS: 19.2" TALL X 17" WIDE X 7.2" DEEP (INCLUDING SURSHIELD)

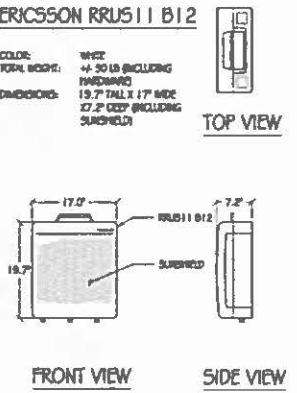

4 ERICSSON RRUS11 B12 DETAIL
1" = 1'

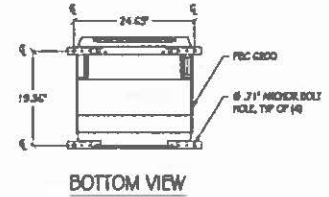

5 PBC 6200 BOLT LAYOUT
1" = 1'

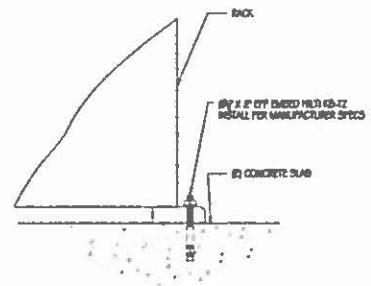

6 PBC 6200 RACK ANCHORING DETAIL
1" = 1'

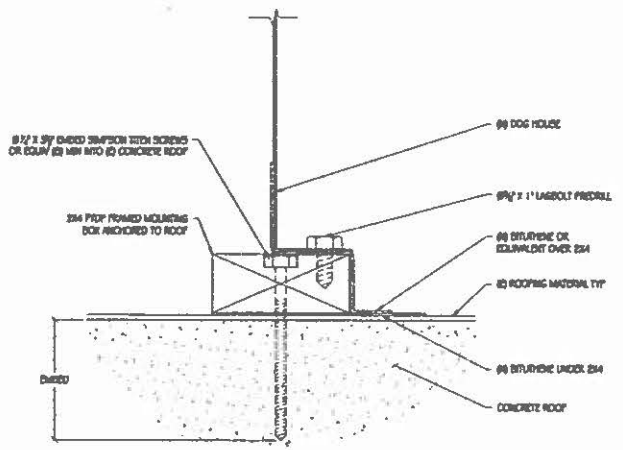

7 DOGHOUSE MOUNTING DETAIL
1/2" = 1'

NOTE: DO NOT DRILL INTO OR CUT PRESTRESSING CABLES, 3-80V AT THE POINT OF PENETRATION TO DETERMINE EXACT LOCATION OF PRESTRESSING CABLES IF APPLICABLE

T-Mobile
1845 SATEWAY BLVD, SUITE 800
CONCORD, CA 94520

PRECISION DESIGN
Drafting, Inc.
Phone (925) 633-8888
11784 Alameda Rd. Suite 20 Auburn, CA 95603



BANK OF AMERICA
5F70359A
1325 MARKET ST
SAN FRANCISCO, CA 94108

ISSUE STATUS

DATE	DESCRIPTION
04/19/15	3D PDF
06/23/15	3D IFC
07/08/15	CD 100%
07/28/15	CD 100%
08/03/16	CD 100%
08/24/16	CD 100%

DRAWN BY: F. CHELLO
CHECKED BY: B. McCOMB
APPROVED BY: B. McCOMB
DWG: 082416
SHEET TITLE:

DETAILS
SHEET NUMBER
A-9

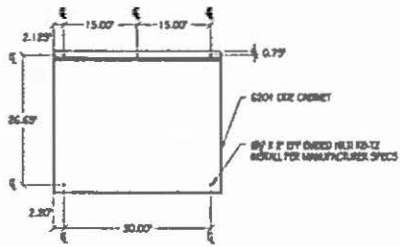

TOP VIEW

1 ODE 6201 CABINET BOLT LAYOUT
1/4" = 1'

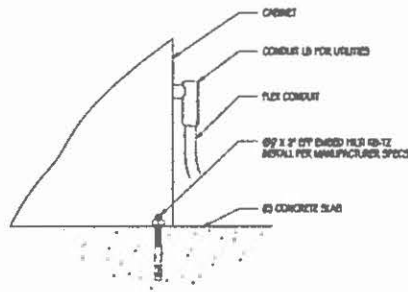

2 ODE 6201 CABINET ANCHORING DETAIL
1/4" = 1'

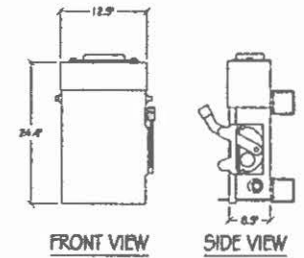

FRONT VIEW

SIDE VIEW

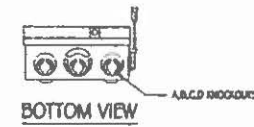

BOTTOM VIEW

3 SERVICE DISCONNECT
3/8" = 1'

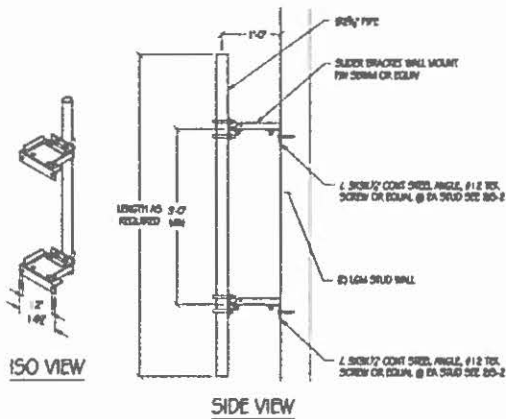

ISO VIEW

SIDE VIEW

4 ANTENNA MOUNT DETAIL
1/4" = 1'

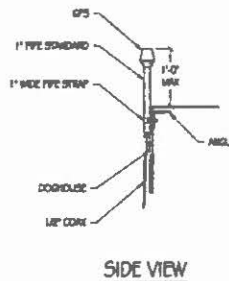

SIDE VIEW

5 GPS ANTENNA DETAIL
1/4" = 1'

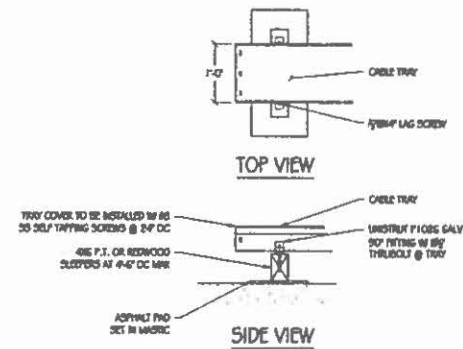

TOP VIEW

SIDE VIEW

6 CABLE TRAY MOUNT DETAIL
1/4" = 1'

NOTE:
CABLE TRAYS SHALL BE FREE OF STUMP OBJECTS
AND BURRS WHICH COULD DAMAGE CABLES.



ISSUE STATUS

DATE	DESCRIPTION
04/13/15	JD 2015
06/22/15	JD 100%
07/09/15	CD 80%
09/11/15	CD 100%
09/11/15	CD 100%
09/24/15	CD 100%

DESIGN BY: F. CHERRILO
CHECKED BY: B. McCUMB
APPROVED BY: B. McCUMB
DATE: 08/24/15
SHEET TITLE:

DETAILS

SHEET NUMBER

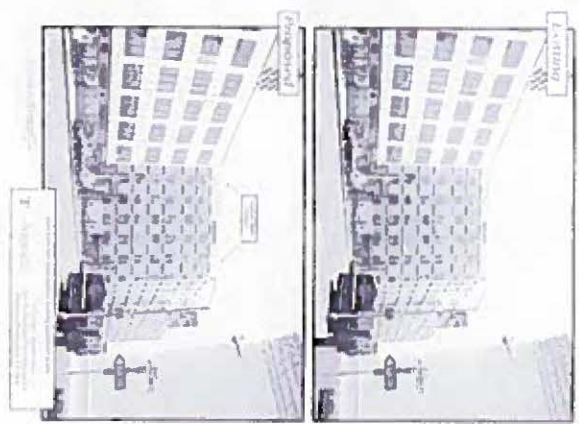
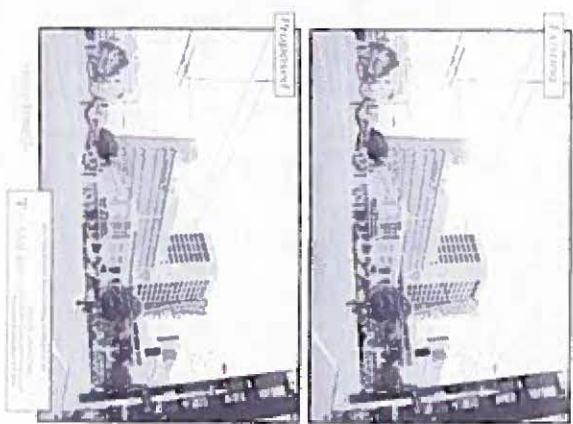

PHOTO SIMULATION

SHEET TITLE

DATE

DESIGNED BY: S. MCKENZIE

DRAWN BY: S. MCKENZIE

CHECKED BY: S. MCKENZIE

APPROVED BY: S. MCKENZIE

SCALE STATUS

DATE	DESCRIPTION
04/17/13	20' 0"
07/29/13	20' 0"
07/29/13	20' 0"
08/14/13	20' 0"
08/29/13	20' 0"

PROJECT NO. 13000000

DATE: 08/29/13

BY: S. MCKENZIE

BANK OF AMERICA

5770359A

1300 MARKET ST

SAN FRANCISCO, CA 94103



PRECISION DESIGN

Drafting, INC.

Phone (930) 822-8048

11788 Alwood Rd., Suite 20 Auburn, CA 95603

T-Mobile

WEST REGION

1850 GATEWAY BLVD, SUITE 800

CONCORD, CA 94530

STRUCTURAL STEEL NOTES

1. ALL STEEL CONSTRUCTION INCLUDING FABRICATION, ERECTION AND MATERIALS SHALL COMPLY WITH ALL REQUIREMENTS OF THE AISC SPECIFICATION FOR THE DESIGN, FABRICATION, AND ERECTION OF STRUCTURAL STEEL FOR BUILDINGS AND THE AISI C308.
2. ALL STRUCTURAL STEEL SHALL BE ASTM A572 GRADE 50 UNLESS NOTED OTHERWISE. ALL WIP SHAPES PLATE & WT (ZED) SHAPES TO BE ASTM A992 (F_y=50,000 PSI) UNLESS NOTED OTHERWISE. ALL STRUCTURAL TUBING (20 OR 120) SHALL BE ASTM A500 GRADE B (F_y=45,000 PSI). ALL STEEL PIPE SHALL BE ASTM A53 (TYPE E OR X, GRADE B) (F_y=35,000 PSI) SCHEDULE 40 WITH OUTSIDE DIMENSIONS UNLESS OTHERWISE NOTED.
3. ALL WELDING SHALL BE PERFORMED USING E70XX ELECTRODES AND SHALL CONFORM TO AISC 4 AND D1.1, WHERE FILLER WELD SIZES ARE NOT SHOWN PROVIDE THE MINIMUM SIZE PER TABLE 4.4 IN THE AISC SPECIFICATION. PAINTED SURFACES SHALL BE TOUCHED UP.
4. ALL WELDING SHALL BE PERFORMED BY QUALIFIED, CERTIFIED WELDERS.
5. BOLTS SHALL BE GALVANNEED ASTM A508 MINIMUM. BOLTED CONNECTIONS SHALL BE WELDING TYPE. SEE PLANS FOR LOCATION, NUMBER, & SIZE OF BOLTS. SPECIAL INSPECTION NOT REQUIRED B.U.O.B.
6. THREADED RODS SHALL BE ASTM F593 OF 304316 STABILIZED STEEL. BOLTED CONNECTIONS SHALL BE WELDING TYPE. SEE PLANS FOR LOCATION, NUMBER, & SIZE OF BOLTS.
7. ALL HOLES FOR BOLTED CONNECTIONS SHALL BE 1/8" C" LARGER THAN THE NOMINAL BOLT DIAMETER. USE STANDARD AISC GAGE AND PITCH FOR BOLTS EXCEPT AS NOTED OTHERWISE. HOLES FOR ANCHOR BOLTS IN SHEAR PLATES MAY BE AISC "OVERSIZE" HOLES WHERE ACCOMPANIED BY OVERSIZED WEDGED ROD WADERS.
8. ALL SHIP FABRICATED STEEL STRUCTURAL MEMBERS FOR EXTERIOR USE SHALL BE HOT DIP GALVANNEED FOR ASTM A123 AFTER FABRICATION & PAINTED PER CUSTOMER SPECIFICATIONS AS REQUIRED. STEEL FOR INTERIOR USE SHALL BE SHIP COAT OR GALVANNEED & PAINTED PER PLAN.
9. ALL FIELD FABRICATED GALVANNEED STEEL THAT IS CUT, GROUND, DRILLED, WELDED OR DAMAGED SHALL BE TREATED WITH ZINC RICH COOL GALVANNEED SPRAY OR COATING. NO RAW STEEL SHALL BE EXPOSED.
10. AT ALL WEB STIFFENER PLATES LEAVE 1/8" FOR K, WHEREVER IS LARGER HOLE @ REINFORCE INSPECTION UNLESS NOTED OTHERWISE.

ROOFING & WATERPROOFING NOTES:

1. CONTRACTOR SHALL JOINTLY GUARANTEE THE FINISHED INSTALLATION AS WEATHER TIGHT AND FREE DRAINING ON COMPLETION DIRECTLY TO THE BUILDING OWNER & TO THE WARRANTIES CARREER FOR ALL WORK SHOWN HEREIN.
2. ALL WORK SHALL BE PERFORMED IN SUB-AREA SUCH THAT CUT OPEN WATERPROOFING SYSTEMS ARE REPAIRED PERMANENTLY OR TEMPORARILY IN OUTSIDE OF ANY INCIDENT WHETHER AS MAY OCCUR DURING CONSTRUCTION.
3. WHEREVER PROFESSIONAL WATERPROOFING SYSTEMS, THE CONTRACTOR SHALL EMPLOY SUBCONTRACTORS APPROVED FOR APPLICATION OF S/S/S SYSTEM AND WITH MINIMUM OF 5 YEARS EXPERIENCE WITH THE APPLICABLE PRODUCTS AND SYSTEMS APPLICATION (e.g., DRY-FIL, GARD-A-LEAK DOCKING FOR ROOFING, SINGLE-PLY ROOFING SYSTEMS, PARROQUEL, ETC.).
4. WHERE APPLICABLE THE CONTRACTOR SHALL EMPLOY THE BUILDING OWNER'S ROOFING CONTRACTOR FOR ALL PATCHWORK.
5. CONTRACTOR IS RESPONSIBLE TO INVESTIGATE ALL WATERPROOFING REQUIREMENTS FOR THE ROOF SYSTEM FROM FROM TO SIGHTING A SEA, AND SHALL NOTIFY THE PROJECT ENGINEER OF ANY DISCREPANCIES IN DETAILS SHOWN THAT MAY RESULT IN SUBSTANDARD WATERPROOFING IN THE FINISHED ASSEMBLY.

EXPANSION & EPOXY ANCHORS

1. EXPANSION AND EPOXY ANCHORS SHALL BE IN CONFORMANCE WITH ALL REQUIREMENTS OF THE 2013 CALIFORNIA BUILDING CODE (CBC).
2. ALL ANCHORS INSTALLED SHALL BE INCLUDED IN EVALUATION REPORTS OF THE INTERACTION CODE COURSE (ICC), AND SHALL BE EVALUATED FOR 2012 ICC MINIMUM REQUIREMENTS, IN THE ICC REPORT.
3. CONCRETE EXPANSION ANCHORS SHALL BE EMB-BOLT 12 BY HILTI, INC., TULSA, OKLAHOMA AS PER ICC REPORT NO. E28-1317 OR APPROVED EQUIVALENTS.
4. ONLY EXPANSION ANCHORS SHALL BE EMB-BOLT 8 BY HILTI, INC., TULSA, OKLAHOMA AS PER ICC REPORT NO. E28-1368 OR APPROVED EQUIVALENTS. ANCHORS SHALL BE INSTALLED A MINIMUM OF 1 1/2" FROM ANY VERTICAL REINFORCING BARS. ANCHORS TO BE SPACED 8" ON-CENTER OR GREATER MINIMUM AND LIMITED TO ONE ANCHOR PER CELL.
5. CONCRETE & GREAT FILLER ONLY REINFORCING EPOXY ANCHORS SHALL BE SET RE-30202 BY HILTI, INC., TULSA, OKLAHOMA AS PER ICC REPORT NO. E28-1352 OR APPROVED EQUIVALENTS.
6. INSTALL EXPANSION AND EPOXY ANCHORS WITH SPECIAL INSPECTION IN ACCORDANCE WITH THE 2010 CBC, CHAPTER 17, AND ALL REQUIREMENTS OF THE MANUFACTURER, THE MANUFACTURER'S ICC APPROVAL AND THESE DRAWINGS.
7. EXPANSION ANCHORS SHALL BE 304316 STABILIZED STEEL (S.S.S.). EPOXY ANCHOR WEDGED ROD SHALL BE ASTM F593 OF 304316 STABILIZED STEEL (S.S.S.).
8. LOCKE AND AVOID REINFORCEMENT AND OTHER EMBEDDED ITEMS WHEN INSTALLING ANCHORS. TYPICAL SEE CONCRETE CORE DRILLING NOTES FOR ADDITIONAL INFORMATION.
9. THE SPECIAL INSPECTOR SHALL MAKE PERIODIC INSPECTIONS DURING ANCHOR INSTALLATION TO VERIFY ANCHOR TYPE AND DIMENSIONS, CONCRETE MEMBER THICKNESS, ANCHOR SPACING, EDGE DISTANCES, REINFORCING JOINTS, HOLE DIAMETER, DEPTH AND CLEARANCES, ANCHOR EMBEDMENT AND ADHERENCE TO MANUFACTURER'S INSTALLATION INSTRUCTIONS. SEE NOTE 10 BELOW FOR FREQUENCY OF INSPECTIONS.
10. 50% OF ALL ANCHORS, INCLUDING ALTERNATE BOLTS IN A GROUP OF ANCHORS, SHALL BE REPEATED PER NOTE 9 ABOVE AND TORQUE TESTED FOR THE ICC REPORT TEST VALUES.

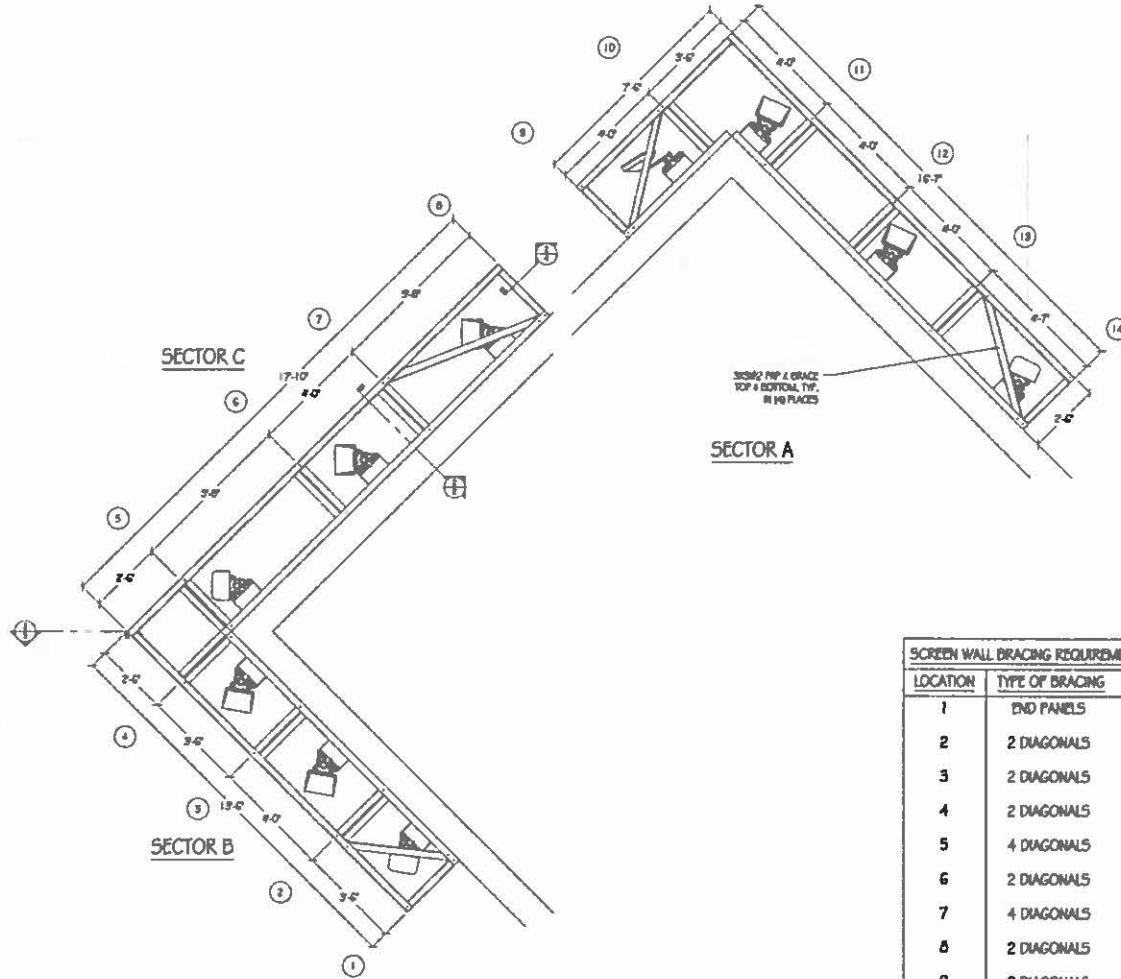

1 FRP SCREEN PLANS
1/2"=1'

SCREEN WALL BRACING REQUIREMENTS	
LOCATION	TYPE OF BRACING
1	END PANELS
2	2 DIAGONALS
3	2 DIAGONALS
4	2 DIAGONALS
5	4 DIAGONALS
6	2 DIAGONALS
7	4 DIAGONALS
8	2 DIAGONALS
9	2 DIAGONALS
10	4 DIAGONALS
11	4 DIAGONALS
12	2 DIAGONALS
13	4 DIAGONALS
14	2 DIAGONALS



PRECISION DESIGN
Drafting, Inc.
Phone (925) 633-6598
11788 Alameda Rd., Suite 20 Alhambra, CA 91803



BANK OF AMERICA
5770359A
1525 MARKET ST
SAN FRANCISCO, CA 94108

ISSUE STATUS

DATE	DESCRIPTION
04/15/15	3D 100%
05/25/15	3D 100%
07/08/15	CD 80%
07/29/15	CD 100%
08/17/16	CD 100% CL
08/24/16	CD 100% CL

DRAWN BY: F. CHRISTELLO
CHECKED BY: B. MACOMB
APPROVED BY: B. MACOMB
DATE: 08/24/16
SHEET TITLE:

FRP SCREEN PLAN
SHEET NUMBER
5-1

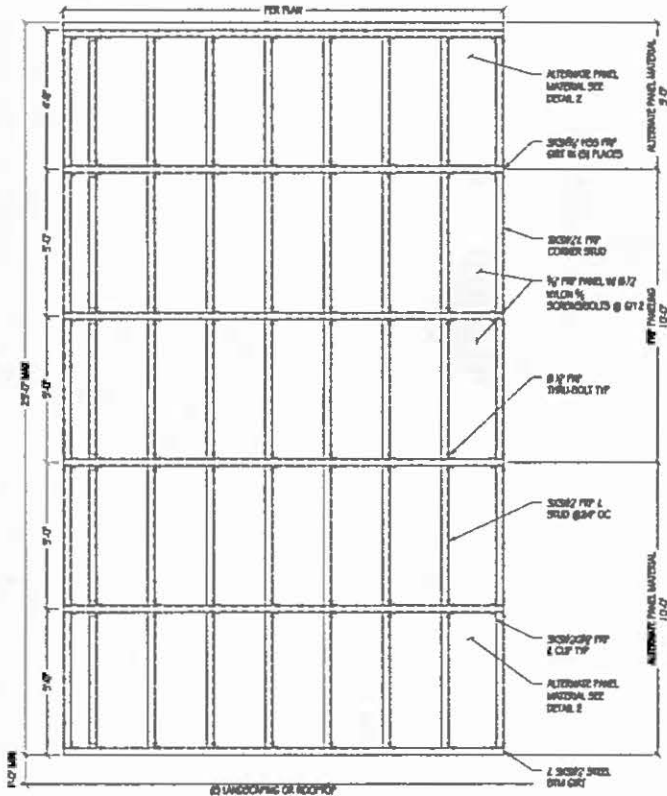

1 FRP SHROUD ELEVATION TYP
 1/8" = 1'

NOTE: BRACING NOT SHOWN FOR CLARITY

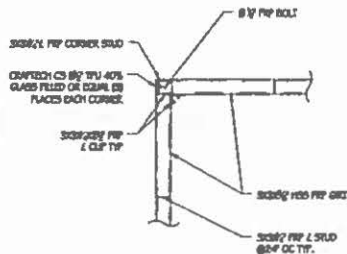

3 CORNER CONNECTION DETAIL
 1/4" = 1'

FRP NOTES

- FRP PANELS ARE TO HAVE THE FOLLOWING MINIMUM DESIGN SPECIFICATIONS:
 A. LONGITUDINAL FLEXURAL STIFFNESS W/ F.S. = 3.0
 B. MODULUS OF ELASTICITY 10 KSI
 C. TENSILE STRENGTH 2800 KSI
- FRP PANELS ARE TO HAVE THE FOLLOWING MINIMUM SPECIFICATIONS:
 A. LONGITUDINAL FLEXURAL STIFFNESS W/ F.S. = 3.0
 B. MODULUS OF ELASTICITY 10 KSI
 C. TENSILE STRENGTH 2800 KSI
- FRP BOLTING MINIMUM SINGLE SHEAR ALLOWABLE VALUES:
 A. 3/8" NYLON BOLT, V=679 PS=3.0
 B. 3/8" NYLON BOLT, V=679 PS=3.0
 C. 3/8" NYLON BOLT, V=679 PS=3.0
 D. 3/8" NYLON BOLT, V=679 PS=3.0
- FRP BOLTING MINIMUM SINGLE SHEAR ALLOWABLE VALUES:
 A. 3/8" NYLON BOLT, V=679 PS=3.0
 B. 3/8" NYLON BOLT, V=679 PS=3.0
 C. 3/8" NYLON BOLT, V=679 PS=3.0
 D. 3/8" NYLON BOLT, V=679 PS=3.0
- FRP BOLTING MINIMUM SINGLE SHEAR ALLOWABLE VALUES:
 A. 3/8" NYLON BOLT, V=679 PS=3.0
 B. 3/8" NYLON BOLT, V=679 PS=3.0
 C. 3/8" NYLON BOLT, V=679 PS=3.0
 D. 3/8" NYLON BOLT, V=679 PS=3.0
- FRP BOLTING MINIMUM SINGLE SHEAR ALLOWABLE VALUES:
 A. 3/8" NYLON BOLT, V=679 PS=3.0
 B. 3/8" NYLON BOLT, V=679 PS=3.0
 C. 3/8" NYLON BOLT, V=679 PS=3.0
 D. 3/8" NYLON BOLT, V=679 PS=3.0
- FRP BOLTING MINIMUM SINGLE SHEAR ALLOWABLE VALUES:
 A. 3/8" NYLON BOLT, V=679 PS=3.0
 B. 3/8" NYLON BOLT, V=679 PS=3.0
 C. 3/8" NYLON BOLT, V=679 PS=3.0
 D. 3/8" NYLON BOLT, V=679 PS=3.0
- FRP BOLTING MINIMUM SINGLE SHEAR ALLOWABLE VALUES:
 A. 3/8" NYLON BOLT, V=679 PS=3.0
 B. 3/8" NYLON BOLT, V=679 PS=3.0
 C. 3/8" NYLON BOLT, V=679 PS=3.0
 D. 3/8" NYLON BOLT, V=679 PS=3.0
- FRP BOLTING MINIMUM SINGLE SHEAR ALLOWABLE VALUES:
 A. 3/8" NYLON BOLT, V=679 PS=3.0
 B. 3/8" NYLON BOLT, V=679 PS=3.0
 C. 3/8" NYLON BOLT, V=679 PS=3.0
 D. 3/8" NYLON BOLT, V=679 PS=3.0
- FRP BOLTING MINIMUM SINGLE SHEAR ALLOWABLE VALUES:
 A. 3/8" NYLON BOLT, V=679 PS=3.0
 B. 3/8" NYLON BOLT, V=679 PS=3.0
 C. 3/8" NYLON BOLT, V=679 PS=3.0
 D. 3/8" NYLON BOLT, V=679 PS=3.0

HARDIPANEL NOTES

- INSTALL PER CSR-1844 AND HARDIPANEL, E-10 INSTALLATION SPECS BY HARDIPANEL PER PLAN.
- APPLY DRYVIT 405 BRACE COAT AND FIBERGLASS MESH FOR DRYVIT SPEC OSB413, OSB413, FINISH TO LAP GAP TO FRP SCREEN.
- APPLY DRYVIT DPF, FIBERGLASS COAT FOR DRYVIT SPEC OSB416, TEXTURE TO MATCH (2) BUILDING.
- PAINT WITH ACRYLIC LATEX PAINT-COLOR TO MATCH (2) BUILDING.

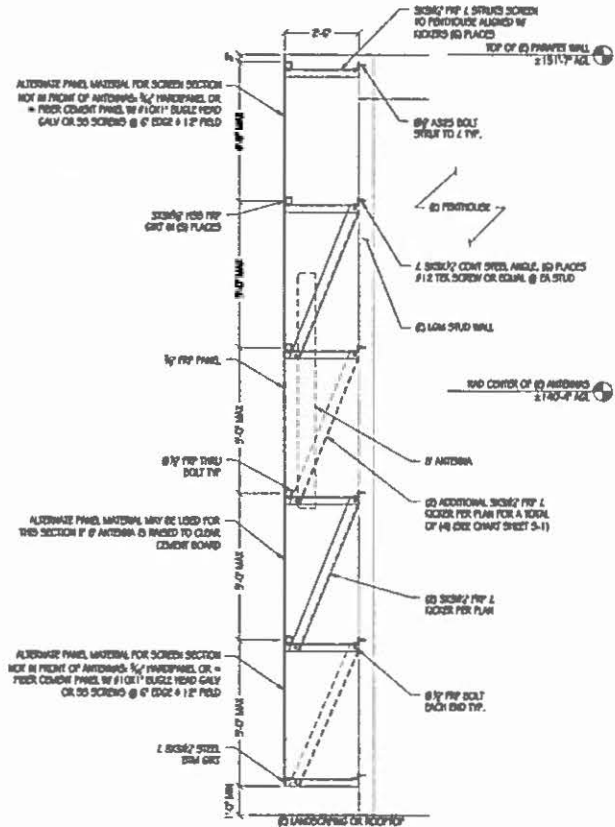

2 FRP SHROUD SECTION VIEW @ BRACING
 1/8" = 1'



4 END PANEL STUD DETAIL
 1/4" = 1'



ISSUE STATUS

DATE	DESCRIPTION
08/13/15	ISS 30%
08/28/15	ISS 100%
09/08/15	CD 30%
09/14/15	CD 100%
09/17/16	CD 100% C
09/24/16	CD 100% C

DESIGN BY: J. CASILLO
 CHECKED BY: E. MACOMB
 APPROVED BY: E. MACOMB
 DATE: 08/24/16
 SHEET TITLE:

ELECTRICAL NOTES

1. ALL ELECTRICAL WORK SHALL CONFORM TO THE NEC AS WELL AS ALL APPLICABLE STATE AND LOCAL CODES.
2. CONTRACTOR SHALL FURNISH AND INSTALL ALL CONDUIT, CONDUCTORS, PULL BOXES, TRANSFORMER PADS, POLE HOISTS, AND PERFORM ALL TRENCHING AND BACKFILLING REQUIRED IN THE FIELD.
3. ALL ELECTRICAL WIRING SHALL BE U.L. APPROVED OR LISTED AND PROTECTED FOR FIELD SPECIFICATIONS.
4. ALL CIRCUIT BREAKERS, FUSES, AND ELECTRICAL EQUIPMENT SHALL HAVE AN INTERRUPTER RATING NOT LESS THAN THE MINIMUM SHORT CIRCUIT CURRENT TO WHICH THEY MAY BE SUBJECT TO WITH A MINIMUM OF 10,000 A.I.C. OR AS REQUIRED.
5. THE ENTIRE ELECTRICAL INSTALLATION SHALL BE GROUNDING AS REQUIRED BY ALL APPLICABLE CODES.
6. ELECTRICAL WIRING SHALL BE COPPER #12 MIN WITH TYPE 90/10, THHN, OR OTHER INSULATION.
7. ALL OUTDOOR EQUIPMENT SHALL HAVE NEMA 3R ENCLOSURE.
8. ALL BARE WIRE SHALL RUN THROUGH SCHEDULE 40 PVC CONDUIT UNLESS OTHERWISE NOTED.
9. A GROUND WIRE IS TO BE PULLED IN ALL CONDUITS.
10. WHERE ELECTRICAL WIRING OCCURS OUTSIDE A STRUCTURE AND HAS THE POTENTIAL FOR EXPOSURE TO WEATHER, WIRING SHALL BE IN SCHEDULE 40 GALVANIZED RIGID STEEL OR FLEXIBLE CONDUIT.

ELECTRIC LEGEND

- (M) MISC.
- (CB) CIRCUIT BREAKER
- (G) SERVICE GROUND
- (W) WIRE CONNECTION
- (T) TANK SWITCH, WATERPROOF
- (L) RECTOR LIGHT
- (G) GFI OUTLET, WATERPROOF
- (S) SMOKE DETECTOR

120/240V PANELBOARD

WHP/PHASE		FED-1		SC LEVEL		10MVC		VOLTS		120/240V, 1Ø, 3Ø	
LOCATION				CELLULAR EQUIPMENT SITE				BUS RMP/		200A	
MOUNTING				EQUIPMENT RACK				MINS. CU.		200A	
LOAD NO.	LOAD VA	LOAD KW	LOAD PF	LOAD DESCRIPTION	BR. AMP/ POLE	CIRCUIT NO.	BR. AMP/ POLE	LOAD DESCRIPTION	LOAD VA	LOAD KW	
1,200	1,200	-	-	(Ø) PFC 6000	25/1	01	02	100CB	5,000	5,000	
2,700	2,700	-	-	(Ø) PFC 6000	25/1	03	04	ØØ 6001 GFI CABINET	5,000	5,000	
2,700	2,700	-	-	(Ø) PFC 6000	25/1	05	06	ØØ RECEPTACLE	100	100	
100	2,700	-	-	(Ø) PFC 6000	07	08	09	SPACE	-	-	
-	-	-	-	(Ø) INDOOR LIGHT	09	10	11	SPACE	-	-	
-	-	-	-	SPACE	11	12	13	SPACE	-	-	
-	-	-	-	SPACE	13	14	15	SPACE	-	-	
-	-	-	-	SPACE	15	16	17	SPACE	-	-	
-	-	-	-	SPACE	17	18	19	SPACE	-	-	
-	-	-	-	SPACE	19	20	21	SPACE	-	-	
-	-	-	-	SPACE	21	22	23	SPACE	-	-	
3,300	8,400	-	-	PHASE TOTALS	25	24	25	PHASE TOTALS	5,100	5,000	
TOTAL VA = 11,000				TOTAL RMP = 109.36A							

NOTE: EXISTING LOADS HAVE NOT BEEN FIELD VERIFIED. THEY ARE APPROXIMATE BASED ON EXISTING CU SIZES. CONTACT THE ENGINEER IF THE LOADS DIFFER FROM THAT WHICH IS SHOWN ON THE PLAN.

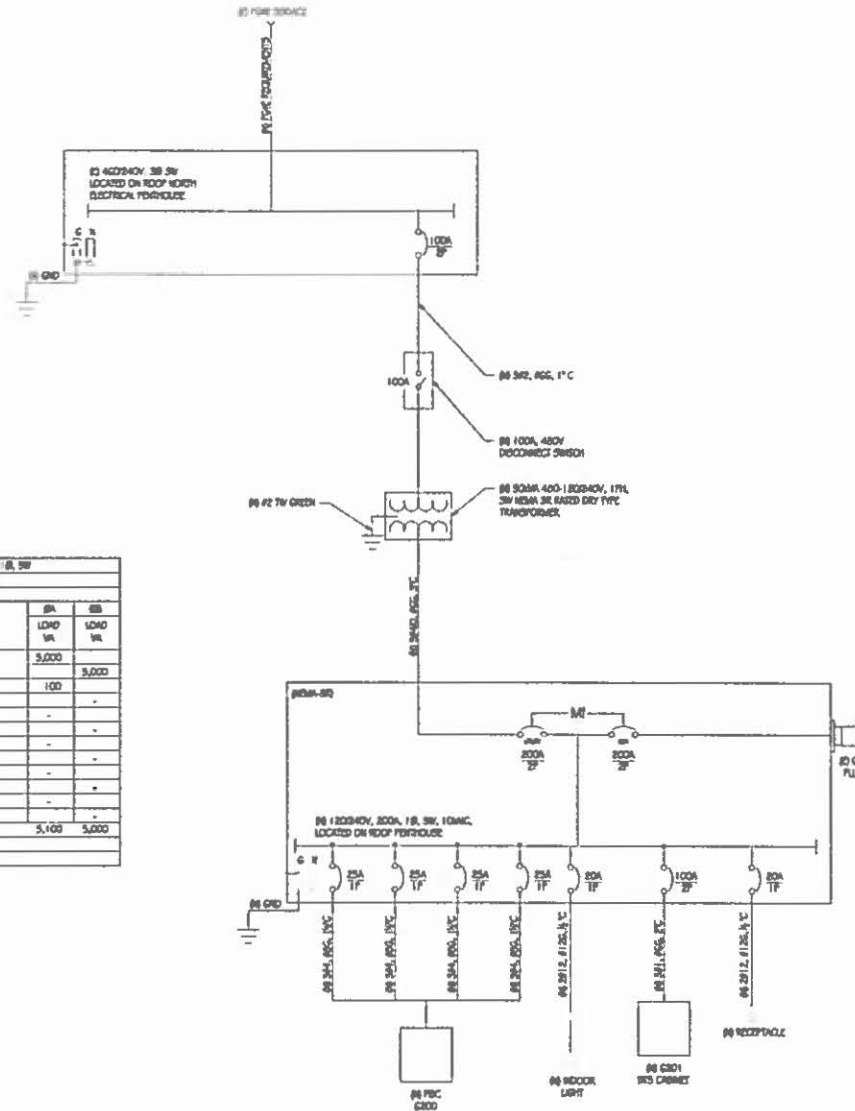

SINGLE LINE DIAGRAM

T-Mobile
 1833 GAITHERY STREET, SUITE 100
 CONCORD, CA 94530

PRECISION DESIGN
Drafting, Inc.
 Phone (925) 827-8548
 11788 Alvarado Pk., Suite 22, Auburn, CA 95603



BANK OF AMERICA
 SF70359A
 1325 MARKET ST
 SAN FRANCISCO, CA 94108

ISSUE STATUS

DATE	DESCRIPTION
04/13/13	2Ø 3Ø/Ø
05/29/15	2Ø 100Ø
07/28/15	ØØ 8ØØ
07/28/15	ØØ 100Ø
08/17/16	ØØ 100Ø CL
08/24/16	ØØ 100Ø CL

OWNER BY: T. CASARDO
 CHECKED BY: S. MACCOMB
 APPROVED BY: S. MACCOMB
 DATE: 08/24/16
 SHEET FIELD:

ELECTRICAL PLAN
 SHEET NUMBER
E-1

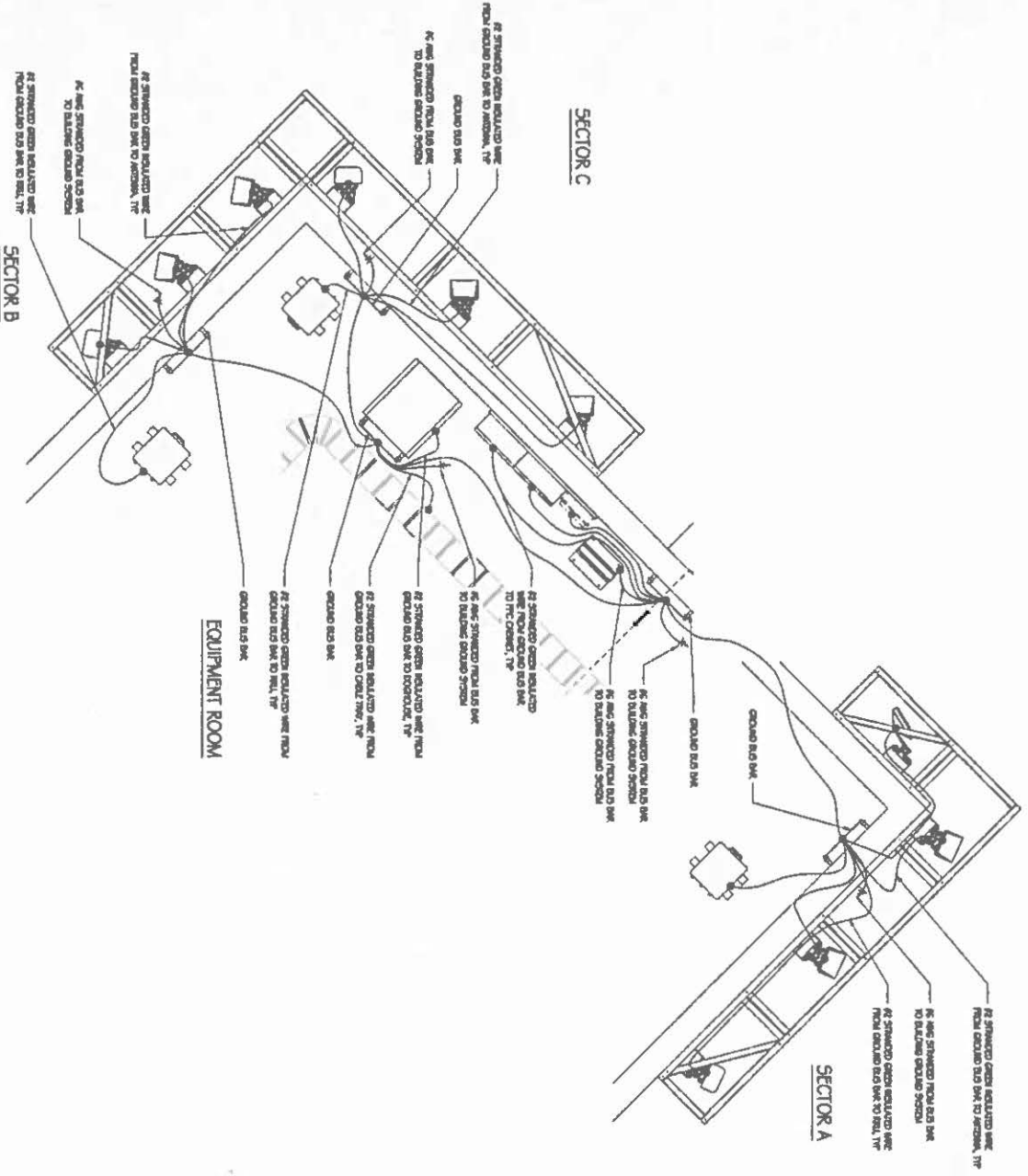

GROUNDING PLAN

GROUND LEGEND

- METALLIC CONDUCTOR
- ▲ POTENTIAL CONDUCT
- ③ 1/2" COPPER BENTONITE HILL
- ④ 1/2" DIA. X 10' LONG COPPER CLAMP GROUND ROD @ 10' O.C.
- ⑤ 1/2" DIA. X 10' LONG COPPER CLAMP GROUND ROD @ 10' O.C. WITH 1/2" DIA. COPPER RINGS
- ⑥ 1/2" DIA. COPPER CLAMP GROUND ROD @ 10' O.C. WITH 1/2" DIA. COPPER RINGS
- ⑦ 1/2" DIA. COPPER CLAMP GROUND ROD @ 10' O.C. WITH 1/2" DIA. COPPER RINGS
- ⑧ 1/2" DIA. COPPER CLAMP GROUND ROD @ 10' O.C. WITH 1/2" DIA. COPPER RINGS
- ⑨ 1/2" DIA. COPPER CLAMP GROUND ROD @ 10' O.C. WITH 1/2" DIA. COPPER RINGS
- ⑩ 1/2" DIA. COPPER CLAMP GROUND ROD @ 10' O.C. WITH 1/2" DIA. COPPER RINGS
- ⑪ 1/2" DIA. COPPER CLAMP GROUND ROD @ 10' O.C. WITH 1/2" DIA. COPPER RINGS
- ⑫ 1/2" DIA. COPPER CLAMP GROUND ROD @ 10' O.C. WITH 1/2" DIA. COPPER RINGS
- ⑬ 1/2" DIA. COPPER CLAMP GROUND ROD @ 10' O.C. WITH 1/2" DIA. COPPER RINGS
- ⑭ 1/2" DIA. COPPER CLAMP GROUND ROD @ 10' O.C. WITH 1/2" DIA. COPPER RINGS
- ⑮ 1/2" DIA. COPPER CLAMP GROUND ROD @ 10' O.C. WITH 1/2" DIA. COPPER RINGS
- ⑯ 1/2" DIA. COPPER CLAMP GROUND ROD @ 10' O.C. WITH 1/2" DIA. COPPER RINGS
- ⑰ 1/2" DIA. COPPER CLAMP GROUND ROD @ 10' O.C. WITH 1/2" DIA. COPPER RINGS
- ⑱ 1/2" DIA. COPPER CLAMP GROUND ROD @ 10' O.C. WITH 1/2" DIA. COPPER RINGS
- ⑲ 1/2" DIA. COPPER CLAMP GROUND ROD @ 10' O.C. WITH 1/2" DIA. COPPER RINGS
- ⑳ 1/2" DIA. COPPER CLAMP GROUND ROD @ 10' O.C. WITH 1/2" DIA. COPPER RINGS
- ㉑ 1/2" DIA. COPPER CLAMP GROUND ROD @ 10' O.C. WITH 1/2" DIA. COPPER RINGS
- ㉒ 1/2" DIA. COPPER CLAMP GROUND ROD @ 10' O.C. WITH 1/2" DIA. COPPER RINGS
- ㉓ 1/2" DIA. COPPER CLAMP GROUND ROD @ 10' O.C. WITH 1/2" DIA. COPPER RINGS
- ㉔ 1/2" DIA. COPPER CLAMP GROUND ROD @ 10' O.C. WITH 1/2" DIA. COPPER RINGS
- ㉕ 1/2" DIA. COPPER CLAMP GROUND ROD @ 10' O.C. WITH 1/2" DIA. COPPER RINGS
- ㉖ 1/2" DIA. COPPER CLAMP GROUND ROD @ 10' O.C. WITH 1/2" DIA. COPPER RINGS
- ㉗ 1/2" DIA. COPPER CLAMP GROUND ROD @ 10' O.C. WITH 1/2" DIA. COPPER RINGS
- ㉘ 1/2" DIA. COPPER CLAMP GROUND ROD @ 10' O.C. WITH 1/2" DIA. COPPER RINGS
- ㉙ 1/2" DIA. COPPER CLAMP GROUND ROD @ 10' O.C. WITH 1/2" DIA. COPPER RINGS
- ㉚ 1/2" DIA. COPPER CLAMP GROUND ROD @ 10' O.C. WITH 1/2" DIA. COPPER RINGS
- ㉛ 1/2" DIA. COPPER CLAMP GROUND ROD @ 10' O.C. WITH 1/2" DIA. COPPER RINGS
- ㉜ 1/2" DIA. COPPER CLAMP GROUND ROD @ 10' O.C. WITH 1/2" DIA. COPPER RINGS
- ㉝ 1/2" DIA. COPPER CLAMP GROUND ROD @ 10' O.C. WITH 1/2" DIA. COPPER RINGS
- ㉞ 1/2" DIA. COPPER CLAMP GROUND ROD @ 10' O.C. WITH 1/2" DIA. COPPER RINGS
- ㉟ 1/2" DIA. COPPER CLAMP GROUND ROD @ 10' O.C. WITH 1/2" DIA. COPPER RINGS
- ㊱ 1/2" DIA. COPPER CLAMP GROUND ROD @ 10' O.C. WITH 1/2" DIA. COPPER RINGS
- ㊲ 1/2" DIA. COPPER CLAMP GROUND ROD @ 10' O.C. WITH 1/2" DIA. COPPER RINGS
- ㊳ 1/2" DIA. COPPER CLAMP GROUND ROD @ 10' O.C. WITH 1/2" DIA. COPPER RINGS
- ㊴ 1/2" DIA. COPPER CLAMP GROUND ROD @ 10' O.C. WITH 1/2" DIA. COPPER RINGS
- ㊵ 1/2" DIA. COPPER CLAMP GROUND ROD @ 10' O.C. WITH 1/2" DIA. COPPER RINGS
- ㊶ 1/2" DIA. COPPER CLAMP GROUND ROD @ 10' O.C. WITH 1/2" DIA. COPPER RINGS
- ㊷ 1/2" DIA. COPPER CLAMP GROUND ROD @ 10' O.C. WITH 1/2" DIA. COPPER RINGS
- ㊸ 1/2" DIA. COPPER CLAMP GROUND ROD @ 10' O.C. WITH 1/2" DIA. COPPER RINGS
- ㊹ 1/2" DIA. COPPER CLAMP GROUND ROD @ 10' O.C. WITH 1/2" DIA. COPPER RINGS
- ㊺ 1/2" DIA. COPPER CLAMP GROUND ROD @ 10' O.C. WITH 1/2" DIA. COPPER RINGS
- ㊻ 1/2" DIA. COPPER CLAMP GROUND ROD @ 10' O.C. WITH 1/2" DIA. COPPER RINGS
- ㊼ 1/2" DIA. COPPER CLAMP GROUND ROD @ 10' O.C. WITH 1/2" DIA. COPPER RINGS
- ㊽ 1/2" DIA. COPPER CLAMP GROUND ROD @ 10' O.C. WITH 1/2" DIA. COPPER RINGS
- ㊾ 1/2" DIA. COPPER CLAMP GROUND ROD @ 10' O.C. WITH 1/2" DIA. COPPER RINGS
- ㊿ 1/2" DIA. COPPER CLAMP GROUND ROD @ 10' O.C. WITH 1/2" DIA. COPPER RINGS

GROUNDING NOTES

1. ALL SYSTEMS ARE SHOWN IN CONFORM WITH ALL APPLICABLE REGULATIONS AND CODES. ALL SYSTEMS SHALL BE INSTALLED IN ACCORDANCE WITH THE NATIONAL ELECTRICAL CODE (NEC) AND ALL APPLICABLE REGULATIONS AND CODES.
2. ALL SYSTEMS SHALL BE INSTALLED IN ACCORDANCE WITH THE NATIONAL ELECTRICAL CODE (NEC) AND ALL APPLICABLE REGULATIONS AND CODES.
3. ALL SYSTEMS SHALL BE INSTALLED IN ACCORDANCE WITH THE NATIONAL ELECTRICAL CODE (NEC) AND ALL APPLICABLE REGULATIONS AND CODES.
4. ALL SYSTEMS SHALL BE INSTALLED IN ACCORDANCE WITH THE NATIONAL ELECTRICAL CODE (NEC) AND ALL APPLICABLE REGULATIONS AND CODES.
5. ALL SYSTEMS SHALL BE INSTALLED IN ACCORDANCE WITH THE NATIONAL ELECTRICAL CODE (NEC) AND ALL APPLICABLE REGULATIONS AND CODES.
6. ALL SYSTEMS SHALL BE INSTALLED IN ACCORDANCE WITH THE NATIONAL ELECTRICAL CODE (NEC) AND ALL APPLICABLE REGULATIONS AND CODES.
7. ALL SYSTEMS SHALL BE INSTALLED IN ACCORDANCE WITH THE NATIONAL ELECTRICAL CODE (NEC) AND ALL APPLICABLE REGULATIONS AND CODES.
8. ALL SYSTEMS SHALL BE INSTALLED IN ACCORDANCE WITH THE NATIONAL ELECTRICAL CODE (NEC) AND ALL APPLICABLE REGULATIONS AND CODES.
9. ALL SYSTEMS SHALL BE INSTALLED IN ACCORDANCE WITH THE NATIONAL ELECTRICAL CODE (NEC) AND ALL APPLICABLE REGULATIONS AND CODES.
10. ALL SYSTEMS SHALL BE INSTALLED IN ACCORDANCE WITH THE NATIONAL ELECTRICAL CODE (NEC) AND ALL APPLICABLE REGULATIONS AND CODES.
11. ALL SYSTEMS SHALL BE INSTALLED IN ACCORDANCE WITH THE NATIONAL ELECTRICAL CODE (NEC) AND ALL APPLICABLE REGULATIONS AND CODES.
12. ALL SYSTEMS SHALL BE INSTALLED IN ACCORDANCE WITH THE NATIONAL ELECTRICAL CODE (NEC) AND ALL APPLICABLE REGULATIONS AND CODES.
13. ALL SYSTEMS SHALL BE INSTALLED IN ACCORDANCE WITH THE NATIONAL ELECTRICAL CODE (NEC) AND ALL APPLICABLE REGULATIONS AND CODES.
14. ALL SYSTEMS SHALL BE INSTALLED IN ACCORDANCE WITH THE NATIONAL ELECTRICAL CODE (NEC) AND ALL APPLICABLE REGULATIONS AND CODES.
15. ALL SYSTEMS SHALL BE INSTALLED IN ACCORDANCE WITH THE NATIONAL ELECTRICAL CODE (NEC) AND ALL APPLICABLE REGULATIONS AND CODES.

<p>PRECISION DESIGN <i>Drafting, Inc.</i></p> <p>Phone: (530) 423-6868 11788 Alwood Rd. Suite 20 Auburn, CA 95603</p>	<p>T-Mobile</p> <p>WEST REGION 1855 BATTERY BLVD, SUITE 800 CONCORD, CA 94530</p>	<p>BANK OF AMERICA</p> <p>SFT0359A 1343 MARKET ST SAN FRANCISCO, CA 94103</p>	<p>ISOLE STATUS</p> <table border="1" style="width: 100%; border-collapse: collapse;"> <tr> <th>NO.</th> <th>DESCRIPTION</th> </tr> <tr> <td>01</td> <td>01/17/13</td> </tr> <tr> <td>02</td> <td>02/27/13</td> </tr> <tr> <td>03</td> <td>03/07/13</td> </tr> <tr> <td>04</td> <td>04/17/13</td> </tr> <tr> <td>05</td> <td>05/17/13</td> </tr> <tr> <td>06</td> <td>06/17/13</td> </tr> <tr> <td>07</td> <td>07/17/13</td> </tr> <tr> <td>08</td> <td>08/17/13</td> </tr> <tr> <td>09</td> <td>09/17/13</td> </tr> <tr> <td>10</td> <td>10/17/13</td> </tr> <tr> <td>11</td> <td>11/17/13</td> </tr> <tr> <td>12</td> <td>12/17/13</td> </tr> <tr> <td>13</td> <td>01/17/14</td> </tr> <tr> <td>14</td> <td>02/17/14</td> </tr> <tr> <td>15</td> <td>03/17/14</td> </tr> <tr> <td>16</td> <td>04/17/14</td> </tr> <tr> <td>17</td> <td>05/17/14</td> </tr> <tr> <td>18</td> <td>06/17/14</td> </tr> <tr> <td>19</td> <td>07/17/14</td> </tr> <tr> <td>20</td> <td>08/17/14</td> </tr> <tr> <td>21</td> <td>09/17/14</td> </tr> <tr> <td>22</td> <td>10/17/14</td> </tr> <tr> <td>23</td> <td>11/17/14</td> </tr> <tr> <td>24</td> <td>12/17/14</td> </tr> <tr> <td>25</td> <td>01/17/15</td> </tr> <tr> <td>26</td> <td>02/17/15</td> </tr> <tr> <td>27</td> <td>03/17/15</td> </tr> <tr> <td>28</td> <td>04/17/15</td> </tr> <tr> <td>29</td> <td>05/17/15</td> </tr> <tr> <td>30</td> <td>06/17/15</td> </tr> <tr> <td>31</td> <td>07/17/15</td> </tr> <tr> <td>32</td> <td>08/17/15</td> </tr> <tr> <td>33</td> <td>09/17/15</td> </tr> <tr> <td>34</td> <td>10/17/15</td> </tr> <tr> <td>35</td> <td>11/17/15</td> </tr> <tr> <td>36</td> <td>12/17/15</td> </tr> <tr> <td>37</td> <td>01/17/16</td> </tr> <tr> <td>38</td> <td>02/17/16</td> </tr> <tr> <td>39</td> <td>03/17/16</td> </tr> <tr> <td>40</td> <td>04/17/16</td> </tr> <tr> <td>41</td> <td>05/17/16</td> </tr> <tr> <td>42</td> <td>06/17/16</td> </tr> <tr> <td>43</td> <td>07/17/16</td> </tr> <tr> <td>44</td> <td>08/17/16</td> </tr> <tr> <td>45</td> <td>09/17/16</td> </tr> <tr> <td>46</td> <td>10/17/16</td> </tr> <tr> <td>47</td> <td>11/17/16</td> </tr> <tr> <td>48</td> <td>12/17/16</td> </tr> <tr> <td>49</td> <td>01/17/17</td> </tr> <tr> <td>50</td> <td>02/17/17</td> </tr> <tr> <td>51</td> <td>03/17/17</td> </tr> <tr> <td>52</td> <td>04/17/17</td> </tr> <tr> <td>53</td> <td>05/17/17</td> </tr> <tr> <td>54</td> <td>06/17/17</td> </tr> <tr> <td>55</td> <td>07/17/17</td> </tr> <tr> <td>56</td> <td>08/17/17</td> </tr> <tr> <td>57</td> <td>09/17/17</td> </tr> <tr> <td>58</td> <td>10/17/17</td> </tr> <tr> <td>59</td> <td>11/17/17</td> </tr> <tr> <td>60</td> <td>12/17/17</td> </tr> <tr> <td>61</td> <td>01/17/18</td> </tr> <tr> <td>62</td> <td>02/17/18</td> </tr> <tr> <td>63</td> <td>03/17/18</td> </tr> <tr> <td>64</td> <td>04/17/18</td> </tr> <tr> <td>65</td> <td>05/17/18</td> </tr> <tr> <td>66</td> <td>06/17/18</td> </tr> <tr> <td>67</td> <td>07/17/18</td> </tr> <tr> <td>68</td> <td>08/17/18</td> </tr> <tr> <td>69</td> <td>09/17/18</td> </tr> <tr> <td>70</td> <td>10/17/18</td> </tr> <tr> <td>71</td> <td>11/17/18</td> </tr> <tr> <td>72</td> <td>12/17/18</td> </tr> <tr> <td>73</td> <td>01/17/19</td> </tr> <tr> <td>74</td> <td>02/17/19</td> </tr> <tr> <td>75</td> <td>03/17/19</td> </tr> <tr> <td>76</td> <td>04/17/19</td> </tr> <tr> <td>77</td> <td>05/17/19</td> </tr> <tr> <td>78</td> <td>06/17/19</td> </tr> <tr> <td>79</td> <td>07/17/19</td> </tr> <tr> <td>80</td> <td>08/17/19</td> </tr> <tr> <td>81</td> <td>09/17/19</td> </tr> <tr> <td>82</td> <td>10/17/19</td> </tr> <tr> <td>83</td> <td>11/17/19</td> </tr> <tr> <td>84</td> <td>12/17/19</td> </tr> <tr> <td>85</td> <td>01/17/20</td> </tr> <tr> <td>86</td> <td>02/17/20</td> </tr> <tr> <td>87</td> <td>03/17/20</td> </tr> <tr> <td>88</td> <td>04/17/20</td> </tr> <tr> <td>89</td> <td>05/17/20</td> </tr> <tr> <td>90</td> <td>06/17/20</td> </tr> <tr> <td>91</td> <td>07/17/20</td> </tr> <tr> <td>92</td> <td>08/17/20</td> </tr> <tr> <td>93</td> <td>09/17/20</td> </tr> <tr> <td>94</td> <td>10/17/20</td> </tr> <tr> <td>95</td> <td>11/17/20</td> </tr> <tr> <td>96</td> <td>12/17/20</td> </tr> <tr> <td>97</td> <td>01/17/21</td> </tr> <tr> <td>98</td> <td>02/17/21</td> </tr> <tr> <td>99</td> <td>03/17/21</td> </tr> <tr> <td>100</td> <td>04/17/21</td> </tr> </table>	NO.	DESCRIPTION	01	01/17/13	02	02/27/13	03	03/07/13	04	04/17/13	05	05/17/13	06	06/17/13	07	07/17/13	08	08/17/13	09	09/17/13	10	10/17/13	11	11/17/13	12	12/17/13	13	01/17/14	14	02/17/14	15	03/17/14	16	04/17/14	17	05/17/14	18	06/17/14	19	07/17/14	20	08/17/14	21	09/17/14	22	10/17/14	23	11/17/14	24	12/17/14	25	01/17/15	26	02/17/15	27	03/17/15	28	04/17/15	29	05/17/15	30	06/17/15	31	07/17/15	32	08/17/15	33	09/17/15	34	10/17/15	35	11/17/15	36	12/17/15	37	01/17/16	38	02/17/16	39	03/17/16	40	04/17/16	41	05/17/16	42	06/17/16	43	07/17/16	44	08/17/16	45	09/17/16	46	10/17/16	47	11/17/16	48	12/17/16	49	01/17/17	50	02/17/17	51	03/17/17	52	04/17/17	53	05/17/17	54	06/17/17	55	07/17/17	56	08/17/17	57	09/17/17	58	10/17/17	59	11/17/17	60	12/17/17	61	01/17/18	62	02/17/18	63	03/17/18	64	04/17/18	65	05/17/18	66	06/17/18	67	07/17/18	68	08/17/18	69	09/17/18	70	10/17/18	71	11/17/18	72	12/17/18	73	01/17/19	74	02/17/19	75	03/17/19	76	04/17/19	77	05/17/19	78	06/17/19	79	07/17/19	80	08/17/19	81	09/17/19	82	10/17/19	83	11/17/19	84	12/17/19	85	01/17/20	86	02/17/20	87	03/17/20	88	04/17/20	89	05/17/20	90	06/17/20	91	07/17/20	92	08/17/20	93	09/17/20	94	10/17/20	95	11/17/20	96	12/17/20	97	01/17/21	98	02/17/21	99	03/17/21	100	04/17/21	<p>GROUNDING PLAN</p> <p>SHEET NUMBER: E-2</p>
NO.	DESCRIPTION																																																																																																																																																																																																													
01	01/17/13																																																																																																																																																																																																													
02	02/27/13																																																																																																																																																																																																													
03	03/07/13																																																																																																																																																																																																													
04	04/17/13																																																																																																																																																																																																													
05	05/17/13																																																																																																																																																																																																													
06	06/17/13																																																																																																																																																																																																													
07	07/17/13																																																																																																																																																																																																													
08	08/17/13																																																																																																																																																																																																													
09	09/17/13																																																																																																																																																																																																													
10	10/17/13																																																																																																																																																																																																													
11	11/17/13																																																																																																																																																																																																													
12	12/17/13																																																																																																																																																																																																													
13	01/17/14																																																																																																																																																																																																													
14	02/17/14																																																																																																																																																																																																													
15	03/17/14																																																																																																																																																																																																													
16	04/17/14																																																																																																																																																																																																													
17	05/17/14																																																																																																																																																																																																													
18	06/17/14																																																																																																																																																																																																													
19	07/17/14																																																																																																																																																																																																													
20	08/17/14																																																																																																																																																																																																													
21	09/17/14																																																																																																																																																																																																													
22	10/17/14																																																																																																																																																																																																													
23	11/17/14																																																																																																																																																																																																													
24	12/17/14																																																																																																																																																																																																													
25	01/17/15																																																																																																																																																																																																													
26	02/17/15																																																																																																																																																																																																													
27	03/17/15																																																																																																																																																																																																													
28	04/17/15																																																																																																																																																																																																													
29	05/17/15																																																																																																																																																																																																													
30	06/17/15																																																																																																																																																																																																													
31	07/17/15																																																																																																																																																																																																													
32	08/17/15																																																																																																																																																																																																													
33	09/17/15																																																																																																																																																																																																													
34	10/17/15																																																																																																																																																																																																													
35	11/17/15																																																																																																																																																																																																													
36	12/17/15																																																																																																																																																																																																													
37	01/17/16																																																																																																																																																																																																													
38	02/17/16																																																																																																																																																																																																													
39	03/17/16																																																																																																																																																																																																													
40	04/17/16																																																																																																																																																																																																													
41	05/17/16																																																																																																																																																																																																													
42	06/17/16																																																																																																																																																																																																													
43	07/17/16																																																																																																																																																																																																													
44	08/17/16																																																																																																																																																																																																													
45	09/17/16																																																																																																																																																																																																													
46	10/17/16																																																																																																																																																																																																													
47	11/17/16																																																																																																																																																																																																													
48	12/17/16																																																																																																																																																																																																													
49	01/17/17																																																																																																																																																																																																													
50	02/17/17																																																																																																																																																																																																													
51	03/17/17																																																																																																																																																																																																													
52	04/17/17																																																																																																																																																																																																													
53	05/17/17																																																																																																																																																																																																													
54	06/17/17																																																																																																																																																																																																													
55	07/17/17																																																																																																																																																																																																													
56	08/17/17																																																																																																																																																																																																													
57	09/17/17																																																																																																																																																																																																													
58	10/17/17																																																																																																																																																																																																													
59	11/17/17																																																																																																																																																																																																													
60	12/17/17																																																																																																																																																																																																													
61	01/17/18																																																																																																																																																																																																													
62	02/17/18																																																																																																																																																																																																													
63	03/17/18																																																																																																																																																																																																													
64	04/17/18																																																																																																																																																																																																													
65	05/17/18																																																																																																																																																																																																													
66	06/17/18																																																																																																																																																																																																													
67	07/17/18																																																																																																																																																																																																													
68	08/17/18																																																																																																																																																																																																													
69	09/17/18																																																																																																																																																																																																													
70	10/17/18																																																																																																																																																																																																													
71	11/17/18																																																																																																																																																																																																													
72	12/17/18																																																																																																																																																																																																													
73	01/17/19																																																																																																																																																																																																													
74	02/17/19																																																																																																																																																																																																													
75	03/17/19																																																																																																																																																																																																													
76	04/17/19																																																																																																																																																																																																													
77	05/17/19																																																																																																																																																																																																													
78	06/17/19																																																																																																																																																																																																													
79	07/17/19																																																																																																																																																																																																													
80	08/17/19																																																																																																																																																																																																													
81	09/17/19																																																																																																																																																																																																													
82	10/17/19																																																																																																																																																																																																													
83	11/17/19																																																																																																																																																																																																													
84	12/17/19																																																																																																																																																																																																													
85	01/17/20																																																																																																																																																																																																													
86	02/17/20																																																																																																																																																																																																													
87	03/17/20																																																																																																																																																																																																													
88	04/17/20																																																																																																																																																																																																													
89	05/17/20																																																																																																																																																																																																													
90	06/17/20																																																																																																																																																																																																													
91	07/17/20																																																																																																																																																																																																													
92	08/17/20																																																																																																																																																																																																													
93	09/17/20																																																																																																																																																																																																													
94	10/17/20																																																																																																																																																																																																													
95	11/17/20																																																																																																																																																																																																													
96	12/17/20																																																																																																																																																																																																													
97	01/17/21																																																																																																																																																																																																													
98	02/17/21																																																																																																																																																																																																													
99	03/17/21																																																																																																																																																																																																													
100	04/17/21																																																																																																																																																																																																													

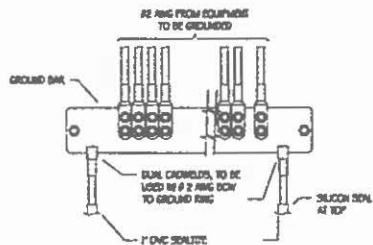

- NOTE:
1. CONTRACTOR TO USESE APPROVED (ZINCS & BITES) ON ALL LUG CONNECTIONS OR APPROVED EQUAL.
 2. ALL LUGS TO BE DUAL HOLE LONG SHAPED AND CRIMPED TRICE WITH W/PCS RECOMMENDED TOOL.

1 GROUNDING BAR CONNECTION DETAIL



2 CADWELD CONNECTIONS

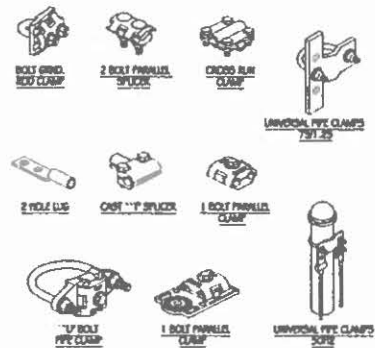

3 MECHANICAL CONNECTIONS

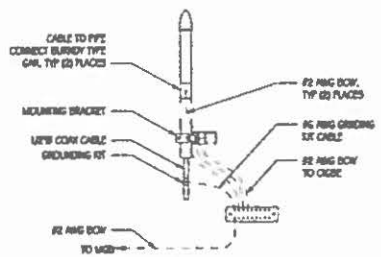

4 GPS ANTENNA GROUNDING

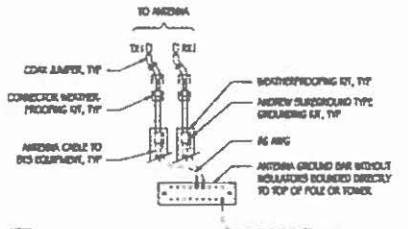

- NOTE:
1. DO NOT INSTALL CABLE GROUND KIT AT A BOND AND ALWAYS DIRECT GROUND WIRE DOWN TO ANTENNA GROUND BAR.
 2. WEATHER PROOFING SHALL BE ANTIWEAR TWO-PART TAPE KIT. COLD SHRINK SHALL NOT BE USED

5 GRND CONNECTION TO GRND BAR

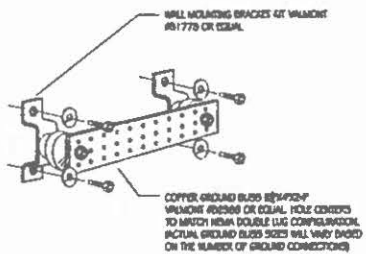

6 GROUND BUS DETAIL

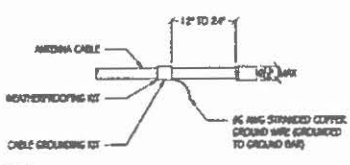

- NOTE:
1. DO NOT INSTALL CABLE GROUND KIT AT A BOND AND ALWAYS DIRECT WIRE DOWN TO GROUND BAR.
 2. GROUNDING KIT SHALL BE TYPE AND PART NUMBER AS SUPPLIED OR RECOMMENDED BY CABLE MANUFACTURER.

7 GRND KIT TO ANTENNA CABLE

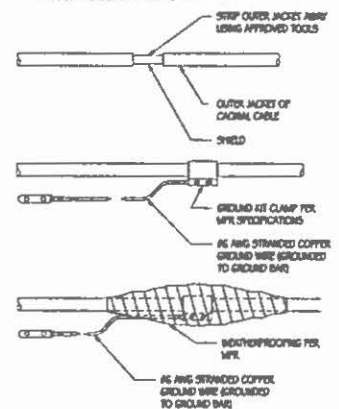

8 GROUND KIT

T-Mobile
 INVENTORY ROOM
 1843 GARDEN BLVD. SUITE 800
 COVINGTON, CA 94020

PRECISION DESIGN Drafting, Inc.
 Phone (415) 833-8888
 11788 Alameda Rd. Suite 207 Alameda, CA 94601



BANK OF AMERICA
 SF70359A
 1525 MARKET ST
 SAN FRANCISCO, CA 94108

ISSUE STATUS

DATE	DESCRIPTION
04/19/13	2D 20%
06/28/13	2D 100%
07/08/13	CD 80%
07/28/13	CD 100%
08/05/13	CD 100%
08/29/13	CD 100%

Drawn By: F. CHERRILO
 Created By: S. McCOMB
 Attached By: S. McCOMB
 Date: 08/29/13
 Sheet Title: GROUNDING DETAILS

EXHIBIT B

Mr. John Updike
Director of Property
Real Estate Division
City and County of San Francisco
25 Van Ness Avenue, Suite 400
San Francisco, CA 94102

RE: Acknowledgment of Commencement Date and Expiration Date, Lease Between
T-Mobile West LLC (Tenant), and the CITY AND COUNTY OF SAN
FRANCISCO (Landlord), for Communications Site premises located at
1 South Van Ness Avenue, San Francisco

Dear Mr. Updike:

This letter will confirm that for all purposes of the Lease, the Commencement Date (as defined in Section 4.2 of the Lease) is _____, 20__.

Please acknowledge your acceptance of this letter by signing and returning a copy of this letter.

Very truly yours,

By: _____

Title: _____

Accepted and Agreed:

By: _____
JOHN UPDIKE
Director of Property

Dated: _____

EXHIBIT C

APPROVED TENANT'S PLANS AND SPECIFICATIONS

PROJECT GENERAL NOTES

1. THE PROJECT IS A LIQUIDATED SUCCESSOR CORPORATION PROJECT.
2. THIS SET OF DRAWINGS IS TO BE USED FOR THE DESIGN AND CONSTRUCTION OF THE PROJECT.
3. THE OWNER SHALL BE RESPONSIBLE FOR OBTAINING ALL NECESSARY PERMITS, APPROVALS AND LICENSES NECESSARY TO CONDUCT THE PROJECT IN ACCORDANCE WITH ALL APPLICABLE LAWS AND REGULATIONS.
4. THE CONTRACTOR SHALL BE RESPONSIBLE FOR OBTAINING ALL NECESSARY PERMITS, APPROVALS AND LICENSES NECESSARY TO CONDUCT THE PROJECT IN ACCORDANCE WITH ALL APPLICABLE LAWS AND REGULATIONS.
5. THE CONTRACTOR SHALL BE RESPONSIBLE FOR OBTAINING ALL NECESSARY PERMITS, APPROVALS AND LICENSES NECESSARY TO CONDUCT THE PROJECT IN ACCORDANCE WITH ALL APPLICABLE LAWS AND REGULATIONS.
6. THE CONTRACTOR SHALL BE RESPONSIBLE FOR OBTAINING ALL NECESSARY PERMITS, APPROVALS AND LICENSES NECESSARY TO CONDUCT THE PROJECT IN ACCORDANCE WITH ALL APPLICABLE LAWS AND REGULATIONS.
7. THE CONTRACTOR SHALL BE RESPONSIBLE FOR OBTAINING ALL NECESSARY PERMITS, APPROVALS AND LICENSES NECESSARY TO CONDUCT THE PROJECT IN ACCORDANCE WITH ALL APPLICABLE LAWS AND REGULATIONS.
8. THE CONTRACTOR SHALL BE RESPONSIBLE FOR OBTAINING ALL NECESSARY PERMITS, APPROVALS AND LICENSES NECESSARY TO CONDUCT THE PROJECT IN ACCORDANCE WITH ALL APPLICABLE LAWS AND REGULATIONS.
9. THE CONTRACTOR SHALL BE RESPONSIBLE FOR OBTAINING ALL NECESSARY PERMITS, APPROVALS AND LICENSES NECESSARY TO CONDUCT THE PROJECT IN ACCORDANCE WITH ALL APPLICABLE LAWS AND REGULATIONS.
10. THE CONTRACTOR SHALL BE RESPONSIBLE FOR OBTAINING ALL NECESSARY PERMITS, APPROVALS AND LICENSES NECESSARY TO CONDUCT THE PROJECT IN ACCORDANCE WITH ALL APPLICABLE LAWS AND REGULATIONS.
11. THE CONTRACTOR SHALL BE RESPONSIBLE FOR OBTAINING ALL NECESSARY PERMITS, APPROVALS AND LICENSES NECESSARY TO CONDUCT THE PROJECT IN ACCORDANCE WITH ALL APPLICABLE LAWS AND REGULATIONS.
12. THE CONTRACTOR SHALL BE RESPONSIBLE FOR OBTAINING ALL NECESSARY PERMITS, APPROVALS AND LICENSES NECESSARY TO CONDUCT THE PROJECT IN ACCORDANCE WITH ALL APPLICABLE LAWS AND REGULATIONS.
13. THE CONTRACTOR SHALL BE RESPONSIBLE FOR OBTAINING ALL NECESSARY PERMITS, APPROVALS AND LICENSES NECESSARY TO CONDUCT THE PROJECT IN ACCORDANCE WITH ALL APPLICABLE LAWS AND REGULATIONS.
14. THE CONTRACTOR SHALL BE RESPONSIBLE FOR OBTAINING ALL NECESSARY PERMITS, APPROVALS AND LICENSES NECESSARY TO CONDUCT THE PROJECT IN ACCORDANCE WITH ALL APPLICABLE LAWS AND REGULATIONS.
15. THE CONTRACTOR SHALL BE RESPONSIBLE FOR OBTAINING ALL NECESSARY PERMITS, APPROVALS AND LICENSES NECESSARY TO CONDUCT THE PROJECT IN ACCORDANCE WITH ALL APPLICABLE LAWS AND REGULATIONS.
16. THE CONTRACTOR SHALL BE RESPONSIBLE FOR OBTAINING ALL NECESSARY PERMITS, APPROVALS AND LICENSES NECESSARY TO CONDUCT THE PROJECT IN ACCORDANCE WITH ALL APPLICABLE LAWS AND REGULATIONS.
17. THE CONTRACTOR SHALL BE RESPONSIBLE FOR OBTAINING ALL NECESSARY PERMITS, APPROVALS AND LICENSES NECESSARY TO CONDUCT THE PROJECT IN ACCORDANCE WITH ALL APPLICABLE LAWS AND REGULATIONS.

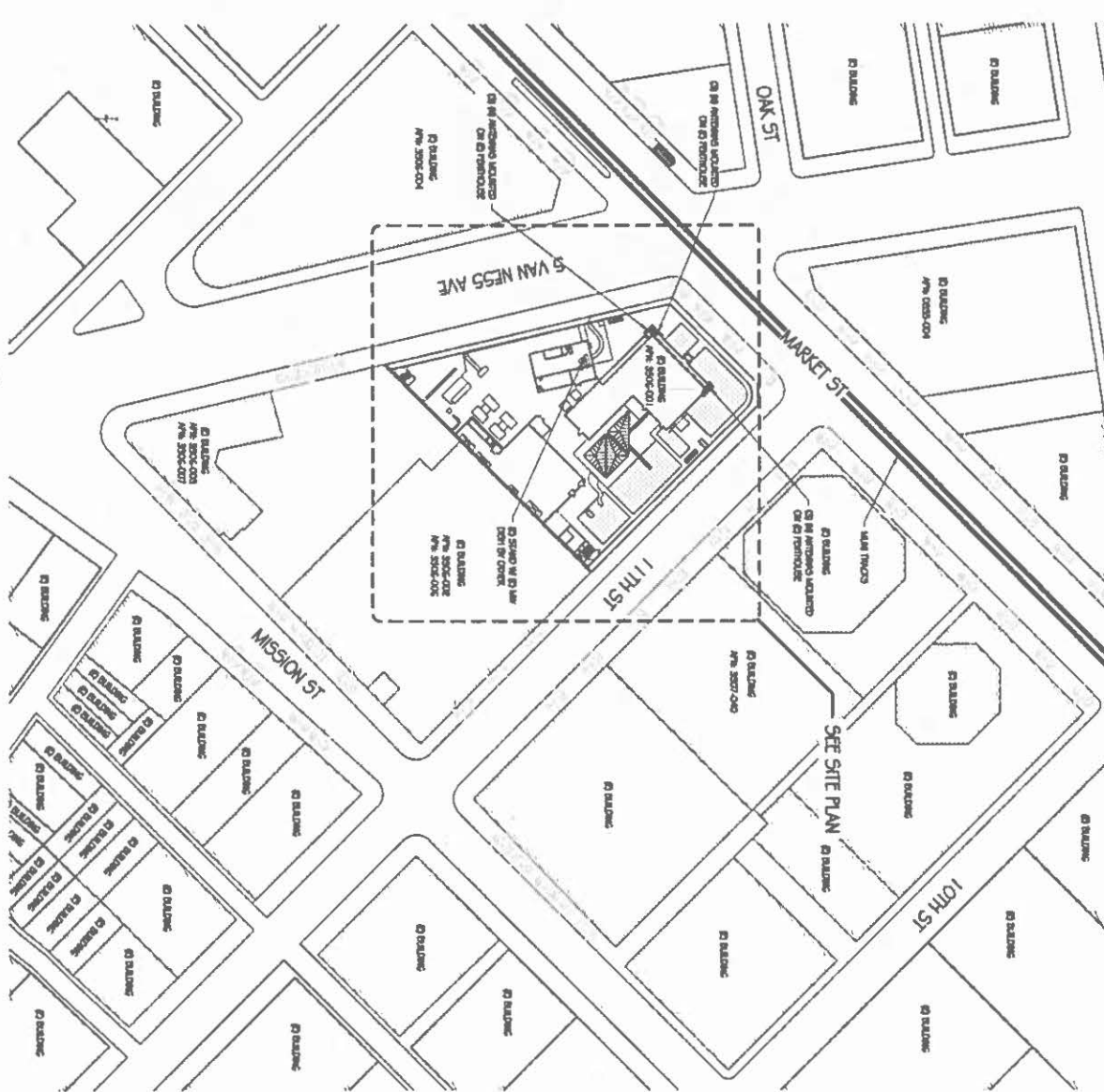

OVERALL SITE PLAN

Scale: 1" = 100'

North Arrow

<p>PRECISION DESIGN <i>Drafting, Inc.</i></p> <p>Phone: (530) 627-6546 11788 Alwood Rd. Suite 20 Auburn, CA 95603</p>	<p>T-Mobile</p> <p>WEST REGION 1823 GATWAY BLVD, SUITE 900 CONCORD, CA 94520</p>		<p>BANK OF AMERICA</p> <p>5770359A 1543 MARKET ST SAN FRANCISCO, CA 94109</p>																		
<p>ISSUE STATUS</p> <table border="1" style="width: 100%; border-collapse: collapse;"> <thead> <tr> <th>NO.</th> <th>DATE</th> <th>DESCRIPTION</th> </tr> </thead> <tbody> <tr> <td>1</td> <td>08/20/15</td> <td>01 10/15</td> </tr> <tr> <td>2</td> <td>07/20/15</td> <td>02 10/15</td> </tr> <tr> <td>3</td> <td>05/21/15</td> <td>03 10/15</td> </tr> <tr> <td>4</td> <td>03/24/15</td> <td>04 10/15</td> </tr> <tr> <td>5</td> <td>02/09/15</td> <td>05 10/15</td> </tr> </tbody> </table> <p>DESIGNED BY: S. NICHOLS APPROVED BY: S. NICHOLS DATE: 02/09/15 SHEET TITLE: OVERALL SITE PLAN</p>				NO.	DATE	DESCRIPTION	1	08/20/15	01 10/15	2	07/20/15	02 10/15	3	05/21/15	03 10/15	4	03/24/15	04 10/15	5	02/09/15	05 10/15
NO.	DATE	DESCRIPTION																			
1	08/20/15	01 10/15																			
2	07/20/15	02 10/15																			
3	05/21/15	03 10/15																			
4	03/24/15	04 10/15																			
5	02/09/15	05 10/15																			
<p>OVERALL SITE PLAN</p> <p>SHEET NUMBER: A-1</p>																					

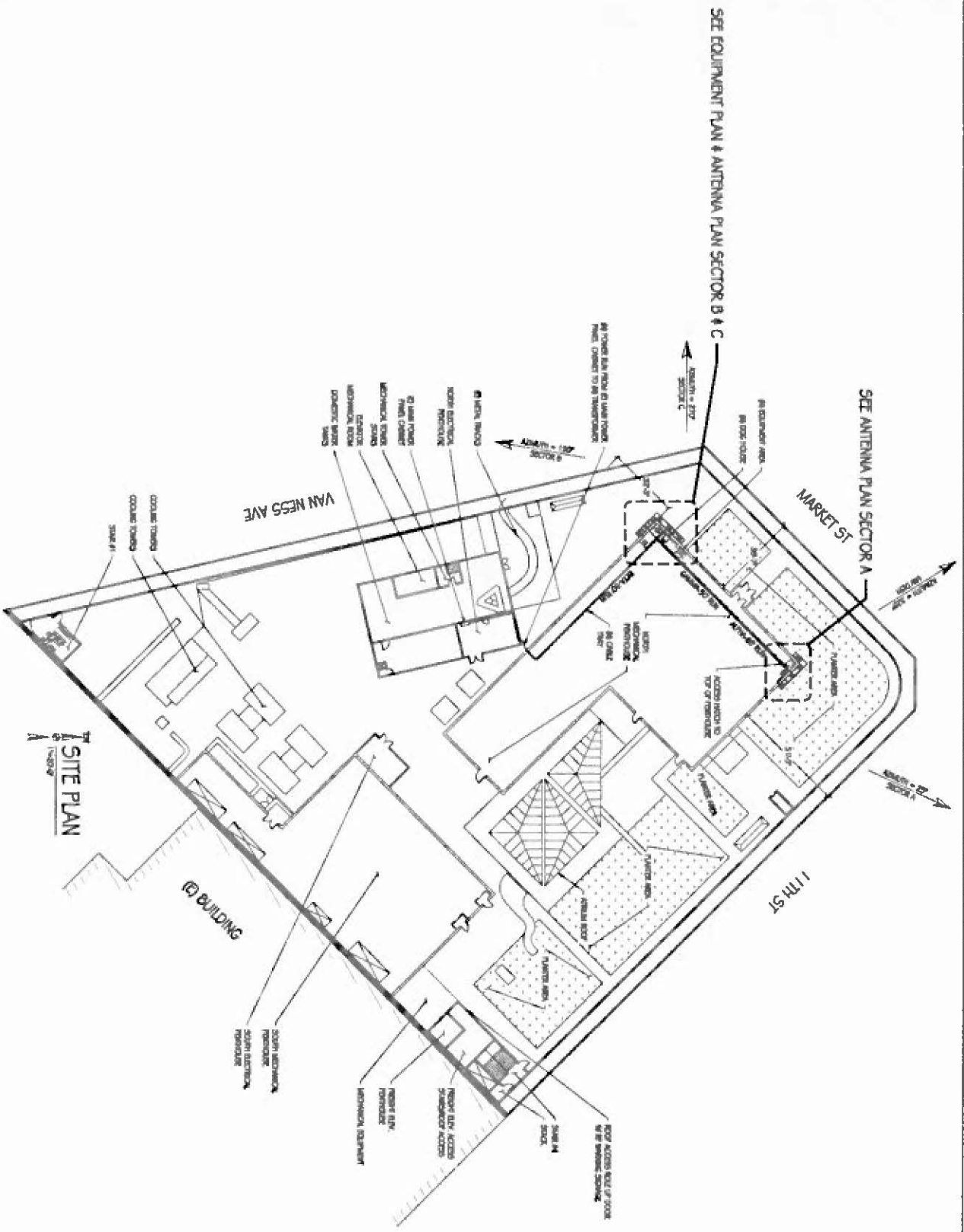

T SITE PLAN
A

ISSUE STATUS	
DATE	DESCRIPTION
07/11/15	BY [Signature]
07/11/15	BY [Signature]
07/08/15	BY [Signature]
07/07/15	BY [Signature]
07/06/15	BY [Signature]
07/05/15	BY [Signature]
07/04/15	BY [Signature]
07/03/15	BY [Signature]
07/02/15	BY [Signature]
07/01/15	BY [Signature]

CHECKED BY: S. WILSON
 APPROVED BY: S. WILSON
 DATE: 08/04/15
 SHEET TITLE: SITE PLAN
 SHEET NUMBER: A-2

BANK OF AMERICA
 9770359A
 1525 MARKET ST
 SAN FRANCISCO, CA 94103



PRECISION DESIGN
Drafting, INC.
 Phone: (505) 823-6548
 11788 Alameda Rd. Suite 20 Auburn, CA 95603

T-Mobile
 WEST REGION
 1853 GATEWAY BLVD, SUITE 900
 CONCORD, CA 94520



BANK OF AMERICA
 5770359A
 1345 MARKET ST
 SAN FRANCISCO, CA 94108

DATE	DESCRIPTION
04/11/13	01 50%
05/28/13	02 100%
07/05/13	03 100%
08/14/13	04 100%
09/24/13	05 100%
10/24/13	06 100%
11/27/13	07 100%
12/17/13	08 100%
01/14/14	09 100%
02/11/14	10 100%
03/11/14	11 100%
04/08/14	12 100%

DESIGNED BY: F. OPREA
 APPROVED BY: B. MCDONNELL
 DATE: 08/21/13
 SHEET NO.: 20/27

ELEVATIONS
 SHEET NUMBER: 20/27

A-6

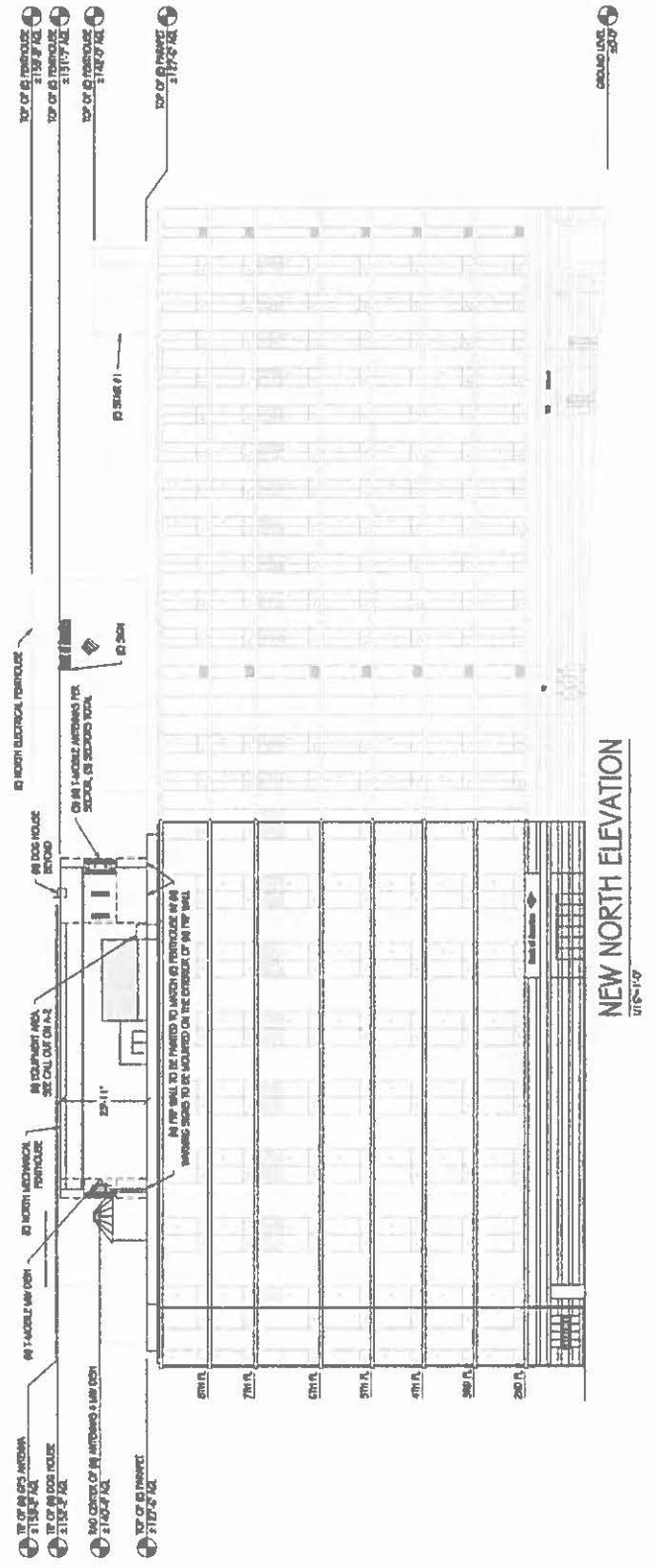
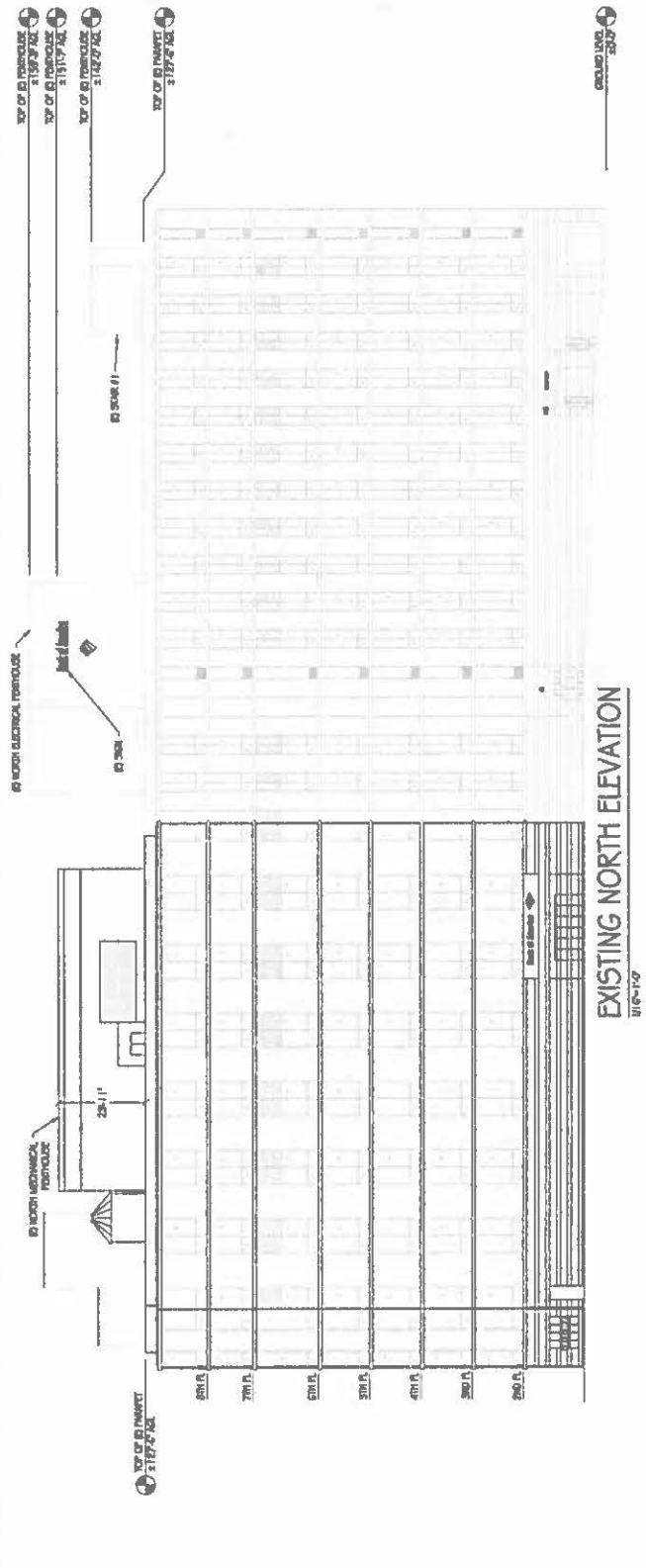

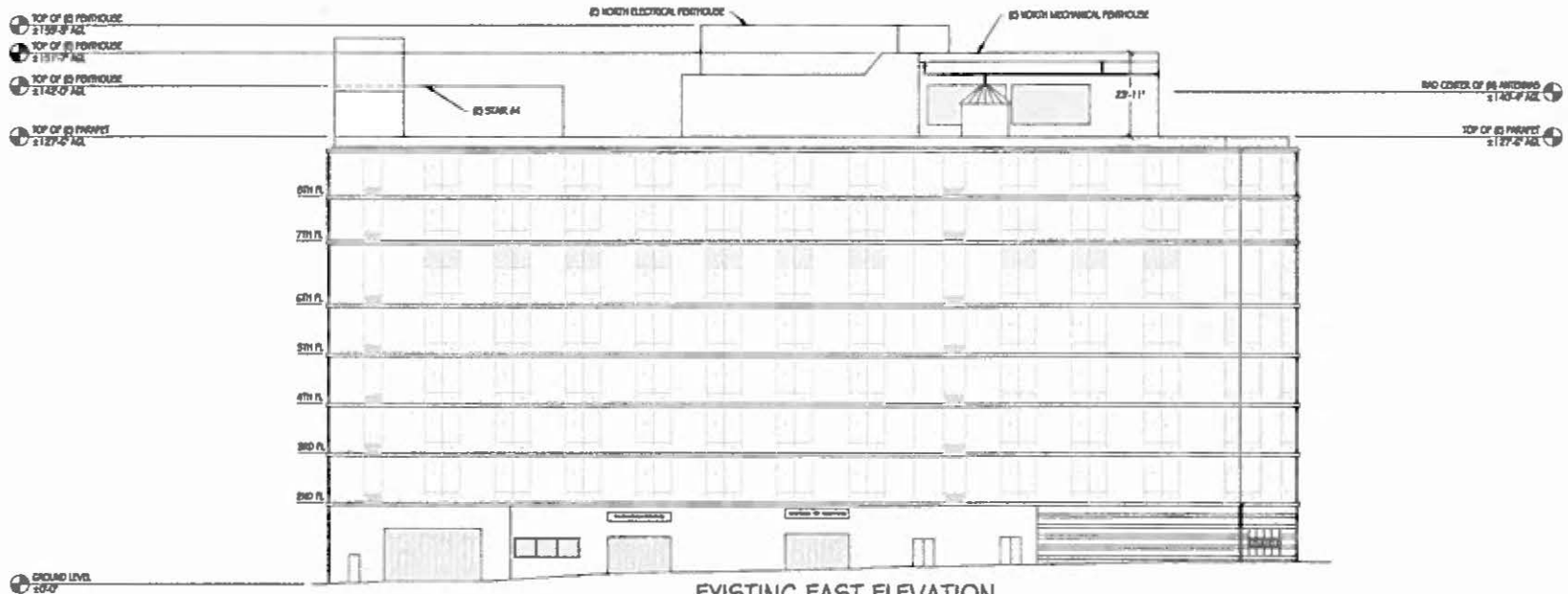

EXISTING EAST ELEVATION
1/16"=1'-0"

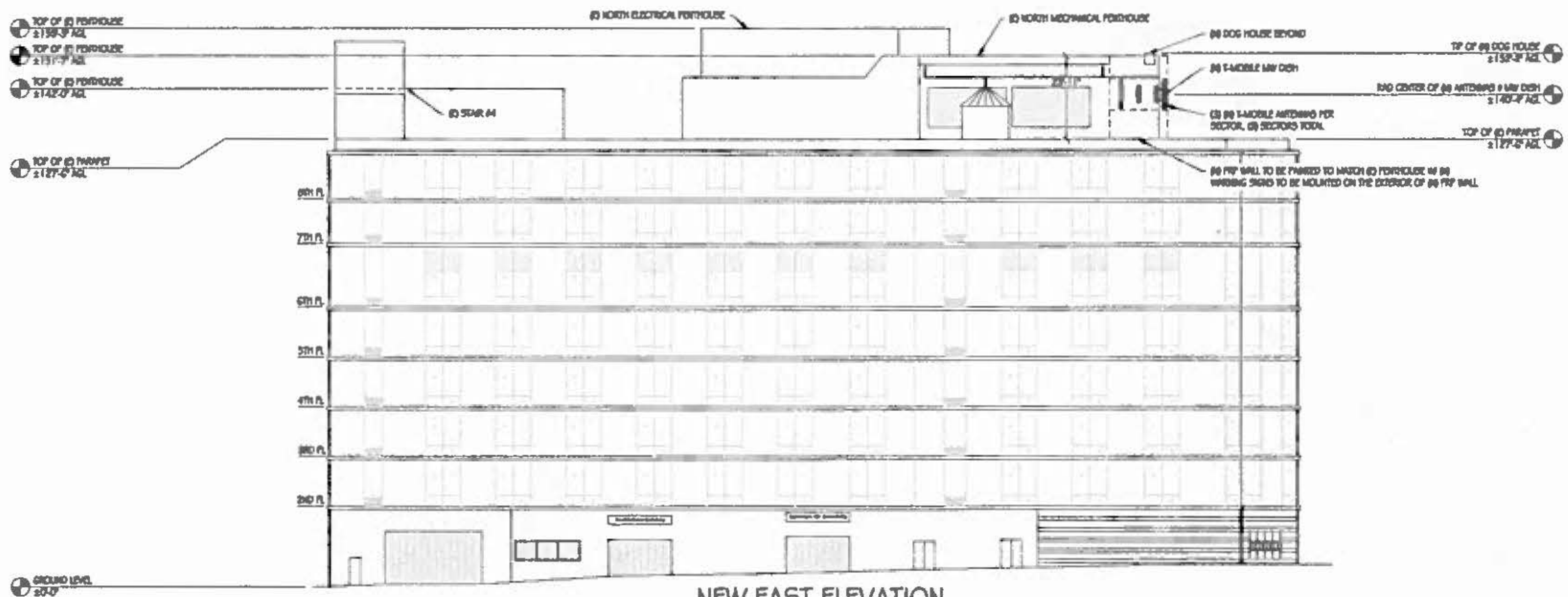

NEW EAST ELEVATION
1/16"=1'-0"

T-Mobile
WEST REGION
1883 SALTWATER BLVD., SUITE 900
CONCORD, CA 94503

PRECISION DESIGN
Shaffling, Inc.
Phone (925) 873-4648
11784 Avenida Rd. Suite 20 Auburn, CA 95603



BANK OF AMERICA
SF70358A
1525 MARKET ST
SAN FRANCISCO, CA 94108

ISSUE STATUS	
DATE	DESCRIPTION
04/13/15	CD 90%
05/29/15	CD 100%
07/02/15	CD 90%
07/28/15	CD 100%
08/17/16	CD 100% G
08/24/16	CD 100% G

DRAWN BY: P. CASIELLO
CHECKED BY: B. MCCOMB
APPROVED BY: B. MCCOMB
DATE: 08/24/16
SHEET TITLE: ELEVATIONS
SHEET NUMBER: A-7

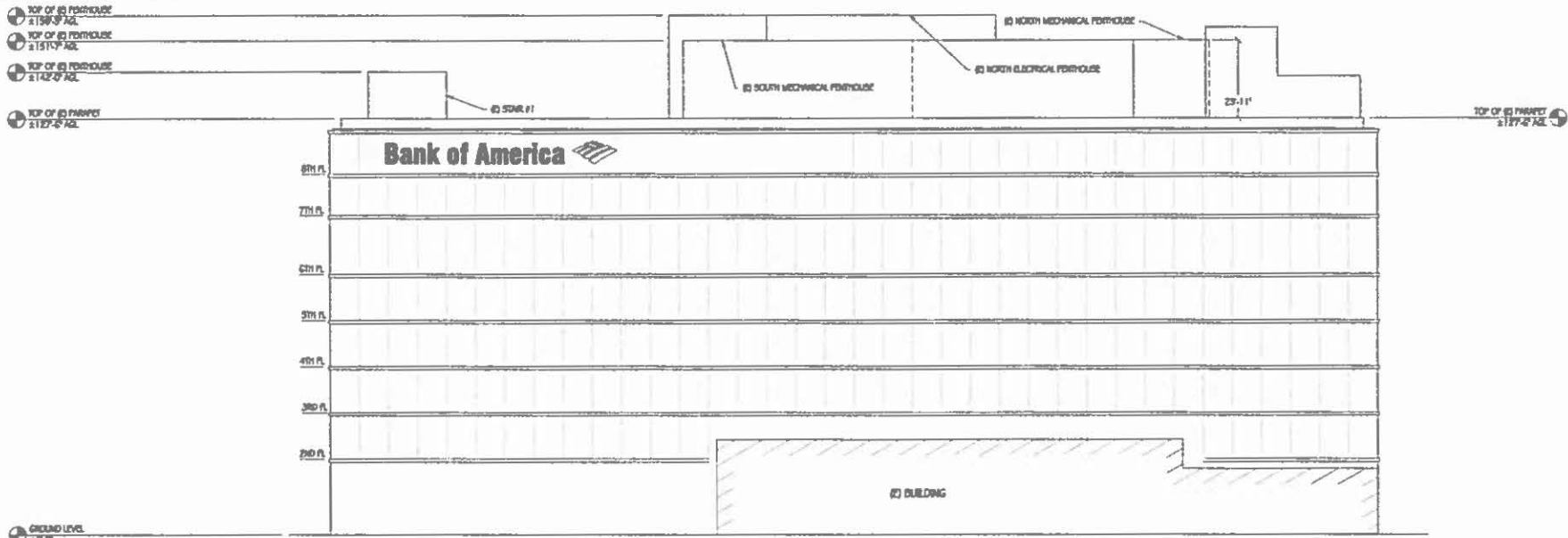

EXISTING SOUTH ELEVATION
1/16" = 1'-0"

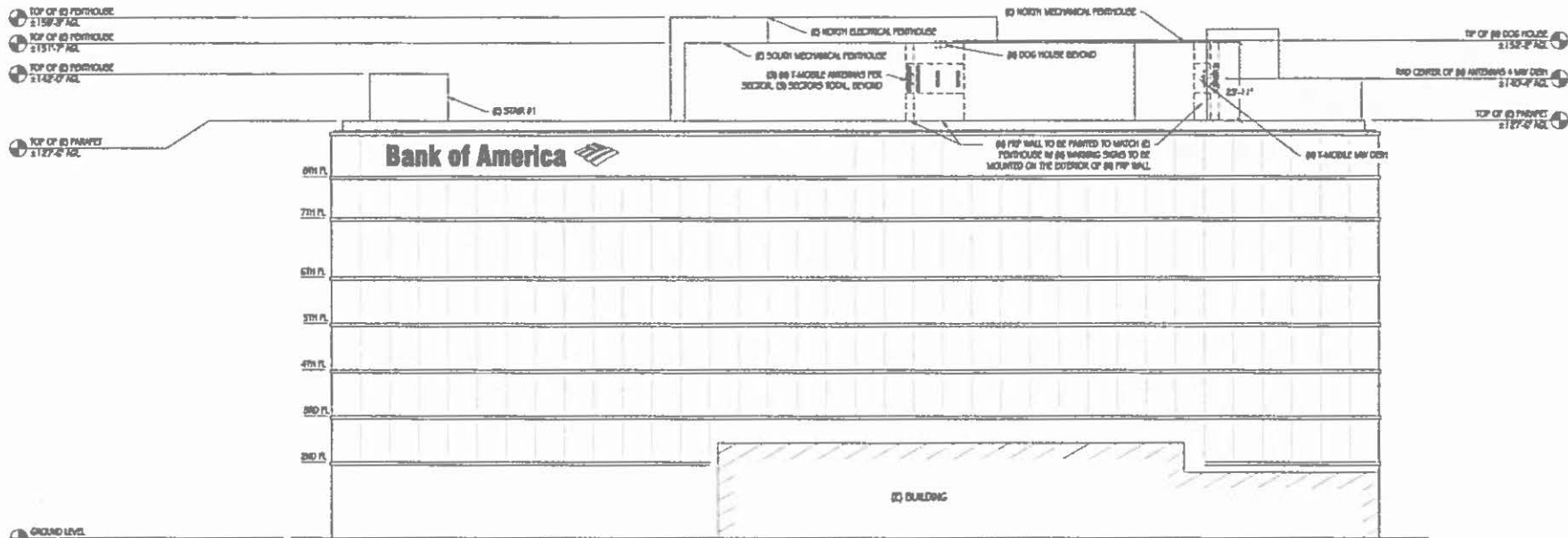

NEW SOUTH ELEVATION
1/16" = 1'-0"

T-Mobile
WEST REGION
1835 OUTWALK BLVD, SUITE 100
CHANDLER, CA 94501

PRECISION DESIGN
Drafting, Inc.
Phone (925) 823-8544
11780 Alameda Pk. Suite 20 Auburn, CA 95603



BANK OF AMERICA
SF70359A
1525 MARKET ST
SAN FRANCISCO, CA 94108

ISSUE STATUS

DATE	DESCRIPTION
DWT 3/15	2D 50%
06/29/15	2D 100%
07/29/15	CD 50%
07/29/15	CD 100%
08/04/16	CD 100% CL
08/04/16	CD 100% CL

DRAWN BY: P. CASALEG
 CHECKED BY: B. MCCOMB
 APPROVED BY: B. MCCOMB
 DATE: 08/04/16
 SHEET TITLE:
ELEVATIONS
 SHEET NUMBER:
A-8

PROJECT GENERAL NOTES

1. THIS FACILITY IS AN UNOCCUPIED WIRELESS TELECOMMUNICATION FACILITY.
2. PLANS ARE NOT TO BE SCALED AND ARE PROVIDED TO BE A DIAGNOSTIC OUTLINE ONLY UNLESS NOTED OTHERWISE.
3. THE SCOPE OF WORK SHALL INCLUDE FURNISHING MATERIALS, EQUIPMENT, APPROXIMATIONS AND LABOR NECESSARY TO COMPLETE ALL INSTALLATIONS AS INDICATED ON THE DRAWINGS.
4. PRIOR TO THE SUBMISSION OF BIDS, THE CONTRACTORS SHALL VISIT THE JOB SITE AND BE RESPONSIBLE FOR ALL CONTRACT DOCUMENTS, FIELD CONDITIONS AND DIMENSIONS, AND CONFIRM THAT THE WORK MAY BE ACCOMPLISHED AS SHOWN PRIOR TO PROCEEDING WITH CONSTRUCTION. ANY DISCREPANCIES ARE TO BE BRUGHT TO THE ATTENTION OF THE CONSTRUCTION MANAGER AND DESIGNER PRIOR TO PROCEEDING WITH THE WORK.
5. IT IS THE RESPONSIBILITY OF THE CONTRACTOR TO PAY FOR PERMIT FEES AND TO OBTAIN SAID PERMITS AND TO COORDINATE INSPECTIONS.
6. THE CONTRACTOR SHALL RECEIVE, IN WRITING, AUTHORIZATION TO PROCEED BEFORE SOMEONE WORK ON ANY ERM NOT CLEARLY DEFINED OR IDENTIFIED BY THE CONTRACT DOCUMENTS.
7. ALL WORK PERFORMED AND MATERIALS INSTALLED SHALL BE IN STRICT ACCORDANCE WITH ALL APPLICABLE CODES, REGULATIONS AND ORDINANCES. CONTRACTOR SHALL GIVE ALL NOTICES AND COMPLY WITH ALL LAWS, ORDINANCES, RULES, REGULATIONS AND LAWFUL ORDERS OF ANY PUBLIC AUTHORITY REGARDING THE PERFORMANCE OF THE WORK.
8. THE GENERAL CONTRACTOR SHALL SUPERVISE AND DIRECT THE WORK USING THE BEST SKILLS AND ATTENTION. THE CONTRACTOR SHALL BE SOLELY RESPONSIBLE FOR ALL CONSTRUCTION METHODS, METHODS, TECHNIQUES, SEQUENCES AND PROCEDURES. CONTRACTOR SHALL ALSO COORDINATE ALL PORTIONS OF THE WORK UNDER THE CONTRACT, INCLUDING CONTACT AND COORDINATION WITH THE CONSTRUCTION MANAGER AND WITH THE UNOCCUPIED AUTHORIZED REPRESENTATIVE.
9. THE CONTRACTOR SHALL MAKE NECESSARY PROVISIONS TO PROTECT EXISTING IMPROVEMENTS, FIRMING, CURBS, GALVANIZED SURFACES, ETC., AND UPON COMPLETION OF WORK, REPAIR ANY DAMAGE THAT OCCURRED DURING CONSTRUCTION TO THE SATISFACTION OF THE PROJECT MANAGER.
10. KEEP GENERAL AREA CLEAN, MAINTAIN FEE, AND REMOVE OF ALL DEBRIS, RUBBISH AND REMOVE EQUIPMENT NOT SPECIFIED AS REMAINING ON THE PROPERTY, LEAVE PREMISES IN CLEAN CONDITION AND FREE FROM PAINT SPOTS, DIRT, OR SOILS OF ANY NATURE.
11. DETAILS ARE PROVIDED TO SHOW END RESULT OF DESIGN. MINOR MODIFICATIONS MAY BE REQUIRED TO SUIT JOB DIMENSIONS OR CONDITIONS, AND SUCH MODIFICATIONS SHALL BE INCLUDED AS PART OF THE WORK.
12. CONTRACTOR TO VERIFY THE LATER REQUIREMENT BY DESIGN.

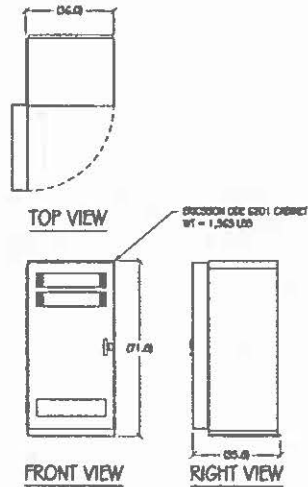

1 ODE 6201 CABINET DETAIL
1/4" = 1'

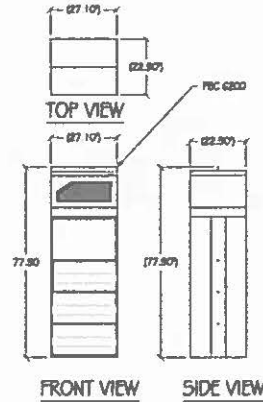

2 PBC 6200 DETAIL
1/4" = 1'

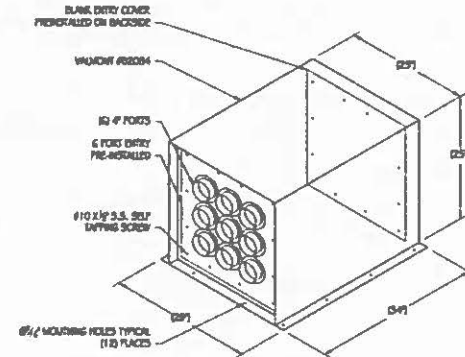

3 DOGHOUSE DETAIL
1/4" = 1'

ERICSSON RRJ11 B12

COLOR: WHITE
TOTAL WEIGHT: 44.50 LB (INCLUDING HARDWARE)
DIMENSIONS: 19.7" TALL X 17" WIDE X 7.2" DEEP (INCLUDING SLUSHIELD)

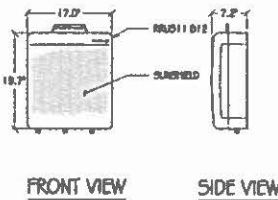

4 ERICSSON RRJ11 B12 DETAIL
1/4" = 1'

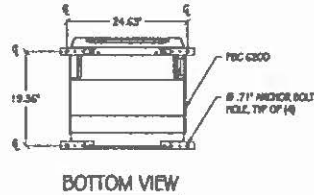

5 PBC 6200 BOLT LAYOUT
1/4" = 1'

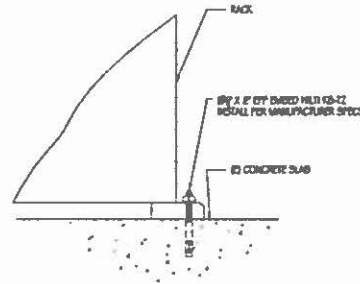

6 PBC 6200 RACK ANCHORING DETAIL
1/4" = 1'

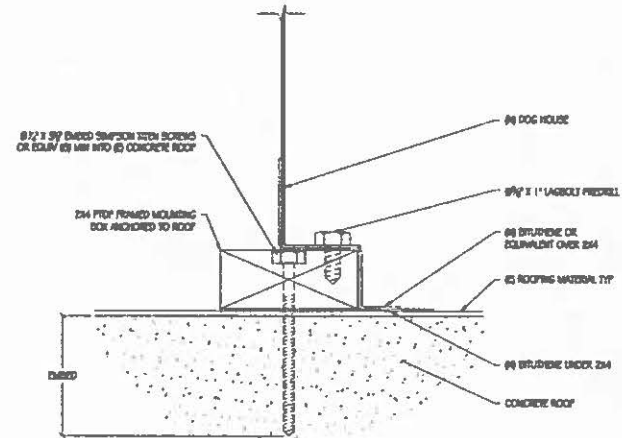

7 DOGHOUSE MOUNTING DETAIL
1/4" = 1'

NOTE: DO NOT DRILL INTO OR CUT PRESTRESSING CABLES. VERIFY AT THE TIME OF PERFORATION TO DETERMINE EXACT LOCATION OF PRESTRESSING CABLES IF APPLICABLE.

T-Mobile
WEST REGION
1831 GAITHERY BLVD., SUITE 100
CORONADO, CA 92009

PRECISION DESIGN
Shreffling, Inc.
Phone (951) 524-4848
11716 Avenida Pk. Suite 20 Auburn, CA 95603



BANK OF AMERICA

SF70359A
1525 MARKET ST
SAN FRANCISCO, CA 94108

ISSUE STATUS

DATE	DESCRIPTION	
04/19/15	2D 30% 06/25/15	3D 100%
07/02/15	CD 80%	
07/28/15	CD 100%	
08/21/16	CD 100% CL	
08/24/16	CD 100% CL	

DRAWN BY: T. CHIFFOLO
CHECKED BY: S. WILCOX
APPROVED BY: S. WILCOX
DATE: 08/24/16

SHEET TITLE: SHEET NUMBER

DETAILS

SHEET NUMBER

A-9

EXHIBIT D
CONDITIONAL USE PERMIT

**No Conditional Use Permit was required by the
City of San Francisco**