

**TREASURE ISLAND / YERBA BUENA ISLAND
REDEVELOPMENT PROJECT
Volume 2 – Chapters IV.I-VIII**



**CITY AND COUNTY OF SAN FRANCISCO
PLANNING DEPARTMENT
CASE NO. 2007.0903E**

STATE CLEARINGHOUSE NO. 2008012105

DRAFT EIR PUBLICATION DATE: JULY 12, 2010

DRAFT EIR PUBLIC HEARING DATE: AUGUST 12, 2010

**DRAFT EIR PUBLIC COMMENT PERIOD: JULY 12, 2010 - AUGUST 26, 2010
(EXTENDED TO SEPTEMBER 10, 2010)**

COMMENTS AND RESPONSES PUBLICATION DATE: MARCH 10, 2011

FINAL EIR CERTIFICATION DATE: APRIL 21, 2011

TREASURE ISLAND / YERBA BUENA ISLAND
REDEVELOPMENT PROJECT
**Final Environmental Impact Report
Volume 2 – Chapters IV.I-VIII**

**CITY AND COUNTY OF SAN FRANCISCO
PLANNING DEPARTMENT
CASE NO. 2007.0903E**

STATE CLEARINGHOUSE NO. 2008012105

DRAFT EIR PUBLICATION DATE: JULY 12, 2010

DRAFT EIR PUBLIC HEARING DATE: AUGUST 12, 2010

**DRAFT EIR PUBLIC COMMENT PERIOD: JULY 12, 2010 - AUGUST 26, 2010
(EXTENDED TO SEPTEMBER 10, 2010)**

COMMENTS AND RESPONSES PUBLICATION DATE: MARCH 10, 2011

FINAL EIR CERTIFICATION DATE: APRIL 21, 2011

Changes from the Draft EIR are indicated by a dot (●) in the left margin.

**TREASURE ISLAND / YERBA BUENA ISLAND
REDEVELOPMENT PROJECT FINAL EIR**

TABLE OF CONTENTS

Volumes 1 – 6

VOLUME 1

SUMMARY

I.	INTRODUCTION	I.1
II.	PROJECT DESCRIPTION	II.1
III.	PLANS AND POLICIES	III.1
IV.	ENVIRONMENTAL SETTING AND IMPACTS	
	A. Land Use and Land Use Planning	IV.A.1
	B. Aesthetics	IV.B.1
	C. Population and Housing	IV.C.1
	D. Cultural and Paleontological Resources.....	IV.D.1
	E. Transportation	IV.E.1
	F. Noise.....	IV.F.1
	G. Air Quality.....	IV.G.1
	H. Greenhouse Gas Emissions	IV.H.1

VOLUME 2

IV.	ENVIRONMENTAL SETTING AND IMPACTS (continued)	
	I. Wind and Shadow	IV.I.1
	J. Recreation.....	IV.J.1
	K. Utilities and Service Systems	IV.K.1
	L. Public Services	IV.L.1
	M. Biological Resources	IV.M.1
	N. Geology and Soils	IV.N.1
	O. Hydrology and Water Quality	IV.O.1
	P. Hazards and Hazardous Materials	IV.P.1
	Q. Mineral and Energy Resources.....	IV.Q.1
	R. Agricultural Resources and Forest Land	IV.R.1
V.	OTHER CEQA ISSUES	V.1
VI.	PROJECT VARIANTS	VI.1
VII.	ALTERNATIVES TO THE PROPOSED PROJECT	VII.1
VIII.	AUTHORS AND PERSONS CONSULTED	VIII.1

VOLUME 3

● **IX. COMMENTS AND RESPONSES**

VOLUME 4

APPENDICES

- A. Notice of Preparation
- B. Public Scoping Report
- C. Transportation Impact Study

VOLUME 5

APPENDICES (continued)

- D. Noise Calculations
- E. Air Quality Health Risk Assessment
- F. Approach to Greenhouse Gas Emissions
- G. Treasure Island Wind Conditions Technical Memorandum
- H. Flora of Yerba Buena Island, San Francisco County
- I. Final Water Supply Assessment

VOLUME 6

● **APPENDICES (continued) – COMMENTS AND RESPONSES**

- J. DEIR Comment Letters
- K. Transcript of Draft EIR Public Hearing

TREASURE ISLAND / YERBA BUENA ISLAND REDEVELOPMENT PROJECT FINAL EIR

TABLE OF CONTENTS Volume 2

IV.	ENVIRONMENTAL SETTING AND IMPACTS (Continued from Volume 1)	
I.	Wind and Shadow	IV.I.1
J.	Recreation.....	IV.J.1
K.	Utilities and Service Systems	IV.K.1
L.	Public Services	IV.L.1
M.	Biological Resources.....	IV.M.1
N.	Geology and Soils	IV.N.1
O.	Hydrology and Water Quality	IV.O.1
P.	Hazards and Hazardous Materials.....	IV.P.1
Q.	Mineral and Energy Resources.....	IV.Q.1
R.	Agricultural Resources and Forest Land	IV.R.1
V.	OTHER CEQA ISSUES	V.1
A.	Growth-Inducing Impacts.....	V.1
B.	Significant Unavoidable Impacts	V.3
C.	Significant Irreversible Environmental Changes Which Would be Caused by the Proposed Project Should it be Implemented.....	V.8
D.	Areas of Known Controversy and Issues to Be Resolved.....	V.9
VI.	PROJECT VARIANTS	VI.1
VII.	ALTERNATIVES TO THE PROPOSED PROJECT	VII.1
VIII.	AUTHORS AND PERSONS CONSULTED	VIII.1

LIST OF FIGURES

●	Figure IV.I.1: Shadows on March 21 at 9 AM.....	IV.I.7
	Figure IV.I.2: Shadows on March 21 at Noon	IV.I.8
●	Figure IV.I.3: Shadows on March 21 at 3 PM	IV.I.9
●	Figure IV.I.4: Shadows on June 21 at 9 AM.....	IV.I.10
	Figure IV.I.5: Shadows on June 21 at Noon	IV.I.11
●	Figure IV.I.6: Shadows on June 21 at 3 PM.....	IV.I.12
●	Figure IV.I.7: Shadows on September 21 at 9 AM	IV.I.13
	Figure IV.I.8: Shadows on September 21 at Noon.....	IV.I.14
●	Figure IV.I.9: Shadows on September 21 at 3 PM.....	IV.I.15
●	Figure IV.I.10: Shadows on December 21 at 9 AM.....	IV.I.16
	Figure IV.I.11: Shadows on December 21 at Noon	IV.I.17
●	Figure IV.I.12: Shadows on December 21 at 3 PM	IV.I.18
	Figure IV.I.13a Test Point Locations – Proposed Project North Portion Detail	IV.I.39
	Figure IV.I.13b Test Point Locations – Proposed Project South Portion Detail	IV.I.41
	Figure IV.I.14 Wind Hazard Locations and Hours Durations for Representative Massing of Proposed Project	IV.I.46

- Figure IV.J.1: Proposed Open Space..... IV.J.15
- Figure IV.K.1: Proposed Wastewater Treatment System IV.K.11
- Figure IV.K.2: Existing Stormdrain System..... IV.K.22
- Figure IV.K.3: Storm Drain Outfall – Plan View IV.K.30
- Figure IV.K.4: Storm Drain Outfall – Section..... IV.K.31
- Figure IV.K.5: Proposed Stormwater Treatment Wetland..... IV.K.32
- Figure IV.K.6: Treasure Island Stormwater Treatment Areas IV.K.36
- Figure IV.K.7: Proposed Off-Site Electrical System..... IV.K.77
- Figure IV.L.1: Police and Fire Stations, Schools, Hospitals, and Libraries in Northeast San Francisco IV.L.2
- Figure IV.M.1: Vegetation Communities on Yerba Buena Island IV.M.5
- Figure IV.M.2: Critical Habitat and EFH for Chinook and Coho ESUs IV.M.26
- Figure IV.M.3: Critical Habitat for Steelhead ESUs IV.M.29
- Figure IV.N.1: Regional Fault Map IV.N.4
- Figure IV.N.2: Areas of Proposed Geotechnical Improvements IV.N.26
- Figure IV.O.1: Proposed FEMA Flood Zone IV.O.8
- Figure IV.P.1: Installation Restoration Site Inventory IV.P.10
- Figure VI.1: Potential Locations for Ground-Mounted Solar Panels..... VI.3
- Figure VI.2: Potential Design Configurations for Solar Panels VI.6
- Figure VI.3: Ferry Terminal Breakwater Variant B1..... VI.21
- Figure VI.4: Ferry Terminal Breakwater Variant B2..... VI.22
- Figure VI.5: Ferry Terminal Breakwater Variant B3..... VI.23
- Figure VII.1: Reduced Development Alternative VII.16
- Figure VII.2: No Ferry Service Alternative VII.49

LIST OF TABLES

- Table IV.I.1: Wind Speeds Exceeded 10 Percent of the Time – Existing and Proposed Project..... IV.I.38
- Table IV.I.2: Wind Hazards – Existing and Proposed Project..... IV.I.43
- Table IV.J.1: Proposed Parks and Open Space IV.J.13
- Table IV.K.1: SFPUC Estimated Retail Water Supplies, 2010 – 2030 with Normal Rainfall IV.K.45
- Table IV.K.2: SFPUC Estimated Average Annual Retail Water Demand..... IV.K.46
- Table IV.K.3: Estimated Water Demand for Treasure Island and Yerba Buena Island (2030) IV.K.57
- Table IV.K.4: Comparison of Projected Water Supply and Demand for Normal, Single Dry, and Multiple Dry Years..... IV.K.59
- Table IV.L.1: Public School Enrollment at Project Buildout Compared to SFSUD Capacity..... IV.L.27
- Table IV.L.2: Library Branches Near the Islands IV.L.34
- Table IV.M.1: Benthic Fish Community Composition and Abundance Indices for Combined Shallow and Deep Water Sites Near Treasure Island, Based on Otter Trawl Data, 2000–2008..... IV.M.12
- Table IV.M.2: Pelagic Fish Community Composition and Abundance Indices for Combined Shallow and Deep Water Sites near Treasure Island, Based on Midwater Trawl Data, 2000 – 2008 IV.M.16
- Table IV.M.3: Special-Status Fish Species that May Occur Within the Project Vicinity.. IV.M.24
- Table IV.M.4: Summary of Surveyed Trees IV.M.32
- Table IV.N.1: Modified Mercalli Intensity Scale IV.N.6

Table IV.N.2:	Active Faults in the Project Area Vicinity	IV.N.8
Table IV.O.1:	Treatment Plant Effluent Water Quality, 2006-2009	IV.O.10
Table IV.O.2:	NPDES Permit Effluent Limitations, 2010–2015	IV.O.10
● Table IV.P.1:	Treasure Island Installation Restoration Site Inventory	IV.P.12
● Table VII.1:	Comparison of Alternatives to the Proposed Project	VII.3
● Table VII.2:	Key Land Use Differences - Proposed Project and Reduced Development Alternative	VII.15
Table VII.3:	Person-Trip Generation by Mode – Proposed Project and Reduced Development Alternative	VII.21
Table VII.4:	Ramp Junction Analysis – Existing, Existing plus Proposed Project, and Existing plus Reduced Development Alternative.....	VII.23
Table VII.5:	Maximum On-Ramp Queues and Average Delays – Existing plus Project and Existing plus Reduced Development Alternative Conditions	VII.24
Table VII.6:	Intersection Levels of Service – Existing and 2030 Cumulative Conditions	VII.25
Table VII.7:	Transit Ridership and Capacity Utilization – Existing plus Project and Existing plus Reduced Development Alternative.....	VII.28
Table VII.8:	Muni Downtown Screenlines – Existing and 2030 Cumulative Conditions	VII.29
● Table VII.9:	Pedestrian Crosswalk Levels of Service – Existing plus Project and Existing plus Reduced Development Alternative	VII.30
Table VII.10:	Modeled Reduced Development Alternative Traffic L_{dn} Noise Levels	VII.34
Table VII.11:	Modeled Cumulative Reduced Development Alternative Traffic L_{dn} Noise Levels	VII.35
Table VII.12:	Estimated Daily Emissions - Proposed Project and Reduced Development Alternative	VII.37
Table VII.13:	Estimated Daily Emissions - Proposed Project and Reduced Development Alternative with Expanded Transit Service Mitigation Measure	VII.38
Table VII.14:	Emissions of GHG - Proposed Project and Reduced Development Alternative	VII.41
Table VII.15:	Emissions of GHGs - Proposed Project and Reduced Development Alternative with Expanded Transit Service Mitigation Measure	VII.42
● Table VII.16:	Key Land Use Differences - Proposed Project and No Ferry Service Alternative	VII.50
Table VII.17:	Estimated Daily Emissions for the Proposed Project and the No Ferry Service Alternative	VII.64
Table VII.18:	Emissions of GHG from the Proposed Project and No Ferry Service Alternative	VII.66
● Table VII.19:	Proposed Parking Supply Ratios and Supply by Land Use.....	VII.72b
● Table VII.20:	San Francisco Off-Street Parking Permitted as Accessory for Select Districts.....	VII.72c
● Table VII.21:	Person-Trip Generation by Mode – Proposed Project and Reduced Parking Alternative	VII.72l
● Table VII.22:	Person-Trip Generation by Mode – Proposed Project and Reduced Parking Alternative (With Implementation of Mitigation Measure M-TR-2)	VII.72m
● Table VII.23:	Person-Trip Generation by Mode – Reduced Development Alternative and Reduced Parking Alternative (Without Implementation of M-TR-2)	VII.72o

- Table VII.24: Transit Ridership and Capacity Utilization – Existing plus Project and Existing plus Reduced Parking Alternative (Prior to Implementation of M-TR-2) VII.72r
- Table VII.25: Pedestrian Crosswalk Levels of Service – Existing plus Project and Existing plus Reduced Parking Alternative..... VII.72v

LIST OF ACRONYMS AND ABBREVIATIONS

AB	Assembly Bill
ABAG	Association of Bay Area Governments
ACCMA	Alameda County Congestion Management Agency
ACM	asbestos-containing material
ADA	Americans with Disabilities Act
ADRP	Archaeological Data Recovery Plan
AEP	Association of Environmental Professionals
afy	acre-feet per year
AGO	California Attorney General's Office
AMI	area median income
AMP	Archaeological Monitoring Program
amsl	above mean sea level
ARB	Air Resources Board
ARDTP	Archaeological Research Design and Treatment Plan
APS	alternative planning strategy
ASCE	American Society of Civil Engineers
AST	above ground storage tank
ATP	Archaeological Testing Plan
AWCS	automated waste collection system
BAAQMD	Bay Area Air Quality Management District
BART	Bay Area Rapid Transit
BATA	Bay Area Toll Authority
BAU	Business as Usual
Bay Bridge	San Francisco-Oakland Bay Bridge
BCDC	San Francisco Bay Conservation and Development Commission
BRAC	Base Realignment and Closure Act
BGM	BAAQMD GHG Model
bgs	below ground surface
BLIP	Branch Library Improvement Program
BMP	Best Management Practice
BOD ₅	Biochemical Oxygen Demand
Btu	British thermal unit
Btu/hr	British Thermal Units per hour
CAB	(Treasure Island and Yerba Buena Island) Citizens Advisory Board
CalARP	California Accidental Release Prevention Program
Cal EPA	California Environmental Protection Agency
Cal OSHA	California Occupational Safety and Health Administration
Caltrans	California Department of Transportation
CAP	Clean Air Plan
CAPCOA	California Air Pollution Control Officers Association
CARB	California Air Resources Board
CAT	California Climate Action Team
CBC	California Building Code
CCAR	California Climate Action Registry
CCR	California Code of Regulations

List of Acronyms and Abbreviations

Cd	Cadmium
CDFG	California Department of Fish and Game
CDPH	California Department of Health
CEC	California Energy Commission
CEQA	California Environmental Quality Act
CERCLA	Comprehensive Environmental Response, Compensation, and Liability Act
CESA	California Endangered Species Act
CFC	chlorofluorocarbon
CGS	California Geological Survey
CH ₄	methane
CHAPIS	Community Health Air Pollution Information System
CHP	California Highway Patrol
CIWMA	California Integrated Waste Management
CIWMB	California Integrated Waste Management Board
CLOMR	Conditional Letter of Map Revision
CMA	county congestion management agency
CMP	Congestion Management Plan
CMTMP	construction traffic management plan
CNG	compressed natural gas
CNPS	California Native Plant Society
CNRA	California Natural Resources Agency
CO	carbon monoxide
CO ₂	Carbon dioxide
CO ₂ e	CO ₂ equivalents
COG	Council of Governments
COPC	Contaminants of Potential Concern
CPMC	California Pacific Medical Center
CPSC	Consumer Product Safety Commission
CPUC	California Public Utilities Commission
CRC	Citizen's Reuse Committee
CRHR	California Register of Historical Resources
CRL	Community Redevelopment Law
CTCDC	California Traffic Control Device Committee
CTMP	Construction Traffic Management Plan
CWA	Clean Water Act
CZMA	Coastal Zone Management Act
dB	decibel
dBA	A-weighted decibel
DBI	San Francisco Department of Building Inspection
DDA	Disposition and Development Agreement
DD-60	Caltrans Deputy Directive 60
DDC	deep dynamic compaction
DEM	digital elevation models
DMMO	Dredged Material Management Office
DoD	(U.S.) Department of Defense
DOE	(U.S.) Department of Energy
DOT	(U.S.) Department of Transportation
DPH	(San Francisco) Department of Public Health
DPM	diesel particulate matter

List of Acronyms and Abbreviations

DPT	(Municipal Transportation Agency) Department of Parking and Traffic
DPW	Department of Public Works
DTSC	Department of Toxic Substances Control
DWR	California Department of Water Resources
EBMUD	East Bay Municipal Utilities District
EBRPD	East Bay Regional Park District
EBS	environmental baseline survey
EFH	Essential Fish Habitat
EIR	Environmental Impact Report
EIS	Environmental Impact Statement
ENA	Exclusive Negotiating Agreement
EOC	Emergency Operations Center
EPA	U.S. Environmental Protection Agency
ERO	Environmental Review Officer
ESL	Environmental Screening Levels
ESU	Evolutionarily Significant UUnit
FAA	Federal Aviation Administration
FARR	Final Archaeological Resources Report
FEMA	Federal Emergency Management Agency
FESA	Federal Endangered Species Act
FHWA	Federal Highway Administration
FICON	Federal Interagency Committee on Noise
FIRM	Flood Insurance Rate Maps
FMP	Fishery Management Plan
FOSL	Finding of Suitability to Lease
FOSET	Finding of Suitability for Early Transfer
FOST	Finding of Suitability to Transfer
FS	Feasibility Study
g	gravity
g/day	grams per day
GGBHTD	Golden Gate Bridge, Highway, and Transportation District
GGIE	Golden Gate International Exposition
GHG	greenhouse gas
gpm	gallons per minute
gsf	gross square feet
GWP	global warming potential
HABS	Historic American Building Survey
HAER	Historic American Engineering Record
HCM	Highway Capacity Manual
HDPE	high-density polyethylene
HEPA	High Efficiency Particulate Air Filter
HFC	hydrofluorocarbon
HHRA	Human Health Risk Assessment
HGL	hydraulic grade line
HMP	Habitat Management Plan
HOV	High Occupancy Vehicle
HRA	Historical Radiological Assessment
HRE	Historic Resource Evaluation (Report)
HRER	Historic Resource Evaluation Response

List of Acronyms and Abbreviations

HRSA	Health Risk Screening Analysis
HUD	(U.S. Department of) Housing and Urban Development
I-80	Interstate 80
I-580	Interstate 580
I-880	Interstate 880
IBC	International Building Code
IOP	(Ferry) Implementation and Operations Plan
IPCC	Intergovernmental Panel on Climate Change
IR	Installation Restoration
ISCOTT	Interdepartmental Staff Committee on Traffic and Transportation
ITE	Institute of Transportation Engineers
km	kilometer
kV	kilovolt
kWh	kilowatt hour
L	liter
lbs	pounds
LCFS	Low Carbon Fuel Standard
L_{dn}	day-night noise level
LEED	Leadership in Energy and Environmental Design
L_{eq}	noise over a specified period of time
LID	low impact design
LIFOC	Lease in Furtherance of Conveyance
L_{max}	maximum instantaneous noise level
LOMR	Letter of Map Revision
LOP	local oversight program
LOS	level of service
● LRA	local redevelopment authority
LTMS	long-term management strategy
M	Richter magnitude
MBTA	Migratory Bird Treaty Act
MEI	Maximally Exposed Individual
MEIR	Maximally Exposed Individual Resident
MEIW	Maximally Exposed Individual Worker
mg/L	milligrams per liter
mgd	million gallons per day
MHHW	Mean Higher High Water
MLD	Most Likely Descendent
MLLW	mean lower low water level
MM	Modified Mercalli (earthquake intensity scale)
mm/yr	millimeters per year
MMPA	Marine Mammal Protection Act
MMT	million metric tons
MMT CO ₂ e	million metric MT of CO ₂ -equivalent
MOA	Memorandum of Agreement
mph	miles per hour
MPO	Metropolitan Planning Organization
MPSA	Merritt-Posey-San Antonio sand and clays
MRSA	methicillin-resistant <i>staphylococcus aureas</i>
MS4	Municipal Separate Stormwater Systems

List of Acronyms and Abbreviations

MSGP	multi-sector general permit
MT	metric tons
MTC	Metropolitan Transportation Commission
MTS	Metropolitan Transportation System
Muni	San Francisco Municipal Railway
MUTCP	Manual on Uniform Traffic Control Devices
MVA	megavolt ampere
MW	megawatt
Mw	Moment Magnitude
MWh	megawatt hour
NAHC	Native American Heritage Commission
NAVD88	North American Vertical Datum of 1988
NEPA	National Environmental Policy Act
NFIP	National Flood Insurance Program
NHL	National Historic Landmarks
NHPA	National Historic Preservation Act
NMFS	National Marine Fisheries Service
NO ₂	nitrogen dioxide
N ₂ O	nitrous oxide
NOP	Notice of Preparation
NO _x	nitrogen oxides
NPDES	National Pollutant Discharge Elimination System
NPL	National Priorities List
NRHP	National Register of Historic Places
NPRA	National Park and Recreation Association
NSTI	Naval Station Treasure Island
NWIC	Northwest Information Center
OEHHA	Office of Environmental Health Hazard Assessment
OES	State Office of Emergency Services
OHP	California Office of Historic Preservation
OHWM	ordinary high water mark
OPR	California Office of Planning and Research
PAH	polycyclic aromatic hydrocarbon
PCB	polychlorinated biphenyls
PCE	tetrachloroethene
PDA	Priority Development Area
PEA	Preliminary Endangerment Assessment
PEIR	Programmatic Environmental Impact Statement
PFC	perfluorocarbon
PG&E	Pacific Gas & Electric
PGA	peak ground acceleration
PM	particulate matter
PM ₁₀	particulate matter less than 10 microns in diameter
PM _{2.5}	particulate matter less than 2.5 microns in diameter
ppb	parts per billion
pphm	parts per hundred million
ppm	part per million
PPV	peak particle velocity
PRG	Preliminary Remediation Goals

List of Acronyms and Abbreviations

PRMMP	Paleontological Resources Monitoring and Management Plan
psi	pound per square inch
PV	photovoltaic
PVC	polyvinyl chloride
R&D	research and development
RAB	Restoration Advisory Board
RAP	Remedial Action Plan
RCFZ	Rodgers Creek Fault Zone
RCRA	Resource Conservation and Recovery Act
REB	Resource Efficient Building
REL	reference exposure level
RHA	Rivers and Harbors Act of 1899
RHNA	Regional Housing Needs Assessment
RI	Remedial Investigation work plan
RO	reverse osmosis
ROD	Record of Decision
ROG	reactive organic gases
RPS	Renewable Portfolio Standard
RWQCB	Regional Water Quality Control Board
SAP	Sampling and Analysis Plan
SARA	Superfund Amendments and Reauthorization Act
SAV	submerged aquatic vegetation
SB 1016	Senate Bill 1016
SBR	styrene butadiene rubber
SCBA	self-contained breathing apparatus
SDC	Seismic Design Category
SEL	single event noise level
SF ₆	sulfur hexafluoride
SFBC	San Francisco Building Code
SFCAP	San Francisco Climate Action Plan
SF CHAMP	San Francisco Chained Activity Modeling Process
SFCTA	San Francisco County Transportation Authority
SFDPH	San Francisco Department of Public Health
SFDPT	San Francisco Department of Parking & Traffic
SFDPW	San Francisco Department of Public Works
SFFD	San Francisco Fire Department
SFMTA	San Francisco Municipal Transportation Agency
SFOBB	San Francisco-Oakland Bay Bridge
SFPD	San Francisco Police Department
SFPL	San Francisco Public Library
SFPUC	San Francisco Public Utilities Commission
SFRPD	San Francisco Recreation and Parks Department
SFUSD	San Francisco Unified School District
SGMP	Site and Groundwater Management Plan
SLR	Sea Level Rise
SO ₂	sulfur dioxide
SOMA	South of Market
sq. ft.	square feet
SSO	sanitary sewer overflow

● SUD	Special Use District
SVOC	semi-volatile organic compounds
SVP	Society for Vertebrate Paleontology
SWPPP	Storm Water Pollution Prevention Plan
SWRCB	State Water Resources Control Board
TAC	toxic air contaminants
TASC	Transportation Advisory Committee
TCE	trichloroethene
TCM	Transportation Control Measures
TCDP	Transit Center District Plan
TDM	transportation demand management
Te	tellurium
TEP	Transit Effectiveness Project
TF/SC	Trickling Filter / Solids Contact
TI	Treasure Island
TICD	Treasure Island Community Development, LLC
TIDA	Treasure Island Development Authority
TIHDI	Treasure Island Homeless Development Initiative
TITMA	Treasure Island Transportation Management Agency
TMDL	Total Maximum Daily Loads
TMP	Transportation Management Plan
TRB	Transportation Research Board
TRP	traffic related pollutants
TSCA	Toxic Substances Control Act
ULI	Urban Land Institute
USACE	U.S. Army Corps of Engineers
U.S. EPA	United States Environmental Protection Agency
USFWS	U.S. Fish and Wildlife Service
UCSF	University of California, San Francisco
USGS	U.S. Geological Survey
UST	underground storage tank
UV	ultraviolet light
UWMP	Urban Water Management Plan
VCA	Voluntary Clean-Up Agreement
VdB	vibration decibels
VMT	vehicle miles traveled
VOC	volatile organic compound
VTS	Vessel Traffic Service program
WAPA	Western Area Power Authority
WDR	Waste Discharge Requirements
WETA	Water Emergency Transit Authority
WHO	World Health Organization
WSA	water supply assessment
WSIP	Water System Improvement Program
WTP	water treatment plant
WWTP	waste water treatment plant
µg/L	micrograms per liter
µg/m ³	micrograms per cubic meter

I. WIND AND SHADOW

This section describes the potential wind and shadow effects of the Proposed Project. The potential shadow effects were determined by digital modeling of a representative massing of the Proposed Project, projecting the shadows that would occur at selected times, and evaluating the resulting shadows. The potential ground-level wind effects were characterized, based upon wind tunnel testing of the same representative model of the Proposed Project and evaluation of the wind testing results.

I.1 SHADOW

This section describes the shadows that would result from the development proposed by the Proposed Project on publicly accessible areas, including proposed public parks, and on other open spaces and recreation areas.

SETTING

Treasure Island and Yerba Buena Island are located in the middle of the Bay, between San Francisco and Oakland. The northern part of Treasure Island currently contains almost exclusively two-story buildings, the central part contains buildings up to three or four stories in height, and the south end of the island contains five-story buildings and hangars that are the tallest structures on the island. Since these buildings are typically widely separated over the island, the shadows cast by these buildings are also widely separated. In contrast, the steep topography and the mature tree cover of Yerba Buena Island substantially shade the existing structures and small open areas of the island.

In addition to the open spaces and parks that would be developed as a part of the Proposed Project, the existing open spaces and recreation areas on Treasure Island associated with the existing elementary school and with the Job Corps campus would remain. The elementary school's two paved playground areas are divided by the two school buildings and by 13th Street. One paved playground is north of the school's north building, and one is south of the south building. Both contain basketball courts as well as courts marked for other games. The recreation areas within the Job Corps campus lie in the general area between 5th Street, 9th Street, Avenue D, and Avenue H (see Figure II.4: Conceptual Land Use Plan, in Chapter II, Project Description, p. II.17). On the Job Corps campus, just south of 9th Street, between Avenue D and Avenue H, are a baseball diamond and open grass fields. Closer to 5th Street, near Avenue D, are two basketball courts, while another basketball court is located west of Avenue D, near its intersection with 9th Street.

The only flat grassy open space on Yerba Buena Island is located on the Yerba Buena Road loop, near the peak of the island, the site of the proposed Hilltop Park.

Regulatory Framework

San Francisco General Plan

The Recreation and Open Space Element of the *San Francisco General Plan* includes the following policy applicable to potential solar access or shading impacts of the Proposed Project:

Policy 2.3 Solar access to public open space should be protected.

The policy promotes solar access and avoiding shade to maintain the usability of public open space and states that the requirements of Planning Code Section 295 apply to the review of projects that could shade property under the jurisdiction of the San Francisco Recreation and Park Commission (Section 295 is discussed further below). Policy 2.3 further states that:

A number of other open spaces designated in this Element or elsewhere in the General Plan are under the jurisdiction of other public agencies, or are privately owned and therefore not protected by the Planning Code amendments. These spaces should be given other forms of protection to assure that they are not shaded during the hours of their most intensive use. Any new shading should be remedied to the extent feasible by expanding opportunities for public assembly and recreation in indoor and outdoor settings.

Sunlight Ordinance and Other Planning Code Regulations

San Francisco Planning Code Section 295, the Sunlight Ordinance, was adopted through voter approval of Proposition K in November 1984 to protect certain public open spaces from shadowing by new structures. Section 295 prohibits the issuance of building permits for structures or additions to structures greater than 40 feet in height that would shade property under the jurisdiction of or designated to be acquired by the Recreation and Park Commission, during the period from one hour after sunrise to one hour before sunset, unless the Planning Commission, following review and comment by the general manager of the Recreation and Park Department in consultation with the Recreation and Park Commission, determines that such shade would have an insignificant impact on the use of such property. There are no properties that are subject to Section 295 on Treasure Island or Yerba Buena Island. Furthermore, under the Proposed Project, there would be no new properties subject to Section 295 because all proposed parks, open spaces, and recreation areas in the Project Area would be owned and maintained by the Treasure Island Development Authority (“TIDA”) and not under the jurisdiction of, or designated to be acquired by, the Recreation and Park Commission.

There are no other Planning Code sections related to shadow that apply to the Project Area. Other Planning Code sections related to shadow, such as Sections 146 and 147, apply to certain zoning districts, with the intent to maintain direct sunlight on public sidewalks in certain downtown areas during critical periods of use and to minimize shadow on

public plazas or other publicly accessible open spaces other than those protected by Section 295. Treasure Island and Yerba Buena Island are not in zoning districts that are subject to the provisions of Planning Code Sections 146 and 147.

IMPACTS

Significance Criteria

The City and County of San Francisco has not formally adopted significance thresholds for impacts related to shadow. The Planning Department's Initial Study Checklist form provides a framework of topics to be considered in evaluating a project's impacts under CEQA.

Implementation of a proposed project would have a significant shadow impact if it were to create new shadow in a manner that would:

- Affect, in an adverse manner, the use of any park or open space under the jurisdiction of the Recreation and Park Commission;
- Substantially affect the usability of other existing publicly accessible open space or outdoor recreation facilities or other public areas.

These two criteria are used to assess the potential impact of the Proposed Project.

Approach to Analysis

Shadow on Property Under the Jurisdiction of the Recreation and Park Commission

Shadows from the Proposed Project would not affect, in an adverse manner, the use of any park or open space under the jurisdiction of the Recreation and Park Commission — the first impact significance criterion, above. All of the Proposed Project development and open space would be located in a redevelopment area on the Islands and all of the proposed open space in the Project Area would be owned and maintained by TIDA, rather than being under the jurisdiction of the Recreation and Park Commission. For these reasons, and because the shadow from the Proposed Project would not extend across San Francisco Bay to the San Francisco waterfront, the Project could not cast shadow on any open space under the jurisdiction of, or designated to be acquired by, the Recreation and Park Commission. Therefore, the Project could not have adverse impacts related to shadowing under the provisions of Planning Code Section 295. Furthermore, Treasure Island and Yerba Buena Island are not in zoning districts subject to the provisions of Planning Code Sections 146 and 147.

Shadow on Other Public Open Space, Outdoor Recreation Facilities, or Other Public Areas

The analysis that follows focuses on the second impact significance criterion, above: whether implementation of the Proposed Project would have a significant impact by creating new shadow

that would substantially affect the usability of other existing publicly accessible open space or outdoor recreation facilities or other public areas.

Methodology and Assumptions

Because no specific building designs or park designs are available at this time, this analysis employs a proposed representative height and massing design to explore the range of effects that the entire development would have on the shadow conditions in the identified existing recreation areas. In addition, the analysis also considers how the entire development affects shadow conditions on the proposed locations of planned parks and open spaces. As described in Section IV.B, Aesthetics, p. IV.B.19, the *Design for Development* associated with the originally proposed Redevelopment Plan envisions construction of a dense cluster of approximately 19 high-rise towers on Treasure Island. The proposed construction program allows for some limited flexibility in the siting of tower volumes (see Figure IV.B.10: Proposed Representative Massing Diagram, p. IV.B.20). In this figure, the “wireframe” boxes above the representative building volumes do not represent maximum height and bulk. Rather, they represent the spatial limits within which the tower volumes may shift when the development program is implemented and specific building designs are proposed. Based on this proposed representative height and massing design, the shadows presented in this analysis are reasonably representative of the shadows that would be cast by the proposed towers once their specific locations and architectural designs have been finalized.

A digital three-dimensional proposed representative height and massing model was used with a computer program to calculate and project sunlight and the resulting shadows from the proposed building masses onto a digital topographic model of Treasure Island. Sunlight and shadow conditions were cast for each of the specific times and dates of interest. The resulting shadow images are shown in the analysis that follows. The shadow locations are superimposed on the outlines of the existing recreation areas, as well as the planned parks and open spaces, to determine the effect of shadowing on the usability of the publicly accessible open spaces, outdoor recreation facilities, and other public areas. All shadows are shown as “new,” including the shadows cast by existing buildings that would be retained as part of the Proposed Project. The shadows from the existing buildings on the Job Corps campus are also shown as “new,” because the intent is to depict the resultant shadows from the Proposed Project and any existing buildings that would remain on Treasure Island. This analysis does not include a comparison between existing shadows and new shadows, because the proposed physical changes to Treasure Island would be so extensive that such a comparison would not produce information that would be useful.

The model did not include Yerba Buena Island. As explained later in this section, the existing shadow patterns on Yerba Buena Island are due to the island’s topography and existing trees. With one exception, the buildings being proposed on Yerba Buena Island would generally be in

the same locations and would generally be the same height as the existing buildings. For these reasons, the shadow patterns on Yerba Buena Island would change very little with implementation of the Proposed Project. Therefore, it was not necessary to model the shadow impacts on Yerba Buena Island.

The shadow diagrams show the shadowing throughout Treasure Island at three times of day¹ (9 AM, noon, and 3 PM) on the winter solstice, the vernal equinox, the summer solstice, and the autumnal equinox – the first day of each season. The shadow diagrams for these dates show the full extent and movement of shadow that would occur between 9 AM and 3 PM throughout the year due to the development under the Proposed Project, based on the specific placement, heights, and bulks of the buildings in the representative height and massing design.

The use of a representative height and massing model cannot precisely show the shadow that would be cast on each of the existing and proposed parks and open spaces. However, the shadows cast using the representative height and massing, which occupies the approximate bounds of the building envelopes (not the actual building designs), provides insight into the range and the extent of the shadowing that can be expected from the Proposed Project.

Project Impacts

Impact WS-1: Shadows from the Proposed Project would reach both existing and proposed parks, open spaces, and recreation areas on the Islands and could substantially affect their usability. (*Less than Significant*)

A series of new parks, open spaces, and recreation areas would be constructed on Treasure Island and Yerba Buena Island as part of the Proposed Project. In addition, some existing open spaces and recreation areas outside of the Project Area, such as the open spaces and recreation areas at the Job Corps campus, would remain. The new parks, open spaces, and recreation areas are shown conceptually on Figure II.7: Proposed Open Space, in Chapter II, Project Description, p. II.30. One of the 15 named and numbered parks and open spaces on Treasure Island, the Cityside Neighborhood Park (#14 on Figure II.7), would be distributed among seven separate locations along the western side of the island. As a part of the Area Plan/SUD, the existing school property would be modified and would become the School Open Space (#15 on Figure II.7). The existing recreation and open space areas now located on the Job Corps campus would remain unchanged by the Proposed Project (the Job Corps recreation areas are not identified on Figure II.7). In addition to the Treasure Island parks and open spaces, four parks and open spaces would be developed on Yerba Buena Island. One of these, Hilltop Park (#17 on Figure II.7), would incorporate the existing grassy open space located on the Yerba Buena Road loop, near the peak of Yerba Buena Island.

¹ Pacific Standard Time (PST) on December 21st, and Pacific Daylight Time (PDT) on the other three dates.

IV. Environmental Setting and Impacts

I. Wind and Shadow

Figures IV.I.1 (Shadows on March 21 at 9 AM) through IV.I.12 (Shadows on December 21 at 3 PM) show shadow from the representative height and massing model for three representative times of day during each of the four seasons. On the winter solstice (December 21), the noontime sun is at its lowest point in the sky, and noontime shadows are at their longest. On the summer solstice (June 21), the noontime sun is at its highest point in the sky, and noontime shadows are at their shortest. Noontime shadows on any other day of the year would fall within the range of shadows presented in Figures IV.I.2, IV.I.5, IV.I.8, and IV.I.11. Shadows are also shown on March 21, near the spring (vernal) equinox (Figures IV.I.2) and on September 21, near the fall (autumnal) equinox (Figure IV.I.8), when day and night are of equal length.

As shown on Figures IV.I.1 through IV.I.12, implementation of the proposed Area Plan/SUD would result in shadowing of the new and existing parks and open spaces on the Islands. Although the high-rise towers would cast the longest shadows, the more abundant low- and mid-rise buildings would, when considered together, cast the largest areas of shadow for the greatest time on Treasure Island parks.

The shadow from the proposed 80-foot-tall building on Block 4Y on Yerba Buena Island is not shown in the figures, but it is generally discussed. See Figure II.6b: Yerba Buena Island Maximum Height Limit Plan, in Chapter II, Project Description, p. II.27, for the location of this building.



SOURCE: ESA, TICD, Turnstone Consulting

TREASURE ISLAND AND YERBA BUENA ISLAND REDEVELOPMENT PROJECT EIR

● **FIGURE IV.I.1: SHADOWS ON MARCH 21 AT 9AM**



SOURCE: ESA, TICD, Turnstone Consulting

TREASURE ISLAND AND YERBA BUENA ISLAND REDEVELOPMENT PROJECT EIR

FIGURE IV.I.2: SHADOWS ON MARCH 21 AT NOON



SOURCE: ESA, TICD, Turnstone Consulting

TREASURE ISLAND AND YERBA BUENA ISLAND REDEVELOPMENT PROJECT EIR

● **FIGURE IV.I.3: SHADOWS ON MARCH 21 AT 3PM**



SOURCE: ESA, TICD, Turnstone Consulting

TREASURE ISLAND AND YERBA BUENA ISLAND REDEVELOPMENT PROJECT EIR

● **FIGURE IV.I.4: SHADOWS ON JUNE 21 AT 9AM**



SOURCE: ESA, TICD, Turnstone Consulting

TREASURE ISLAND AND YERBA BUENA ISLAND REDEVELOPMENT PROJECT EIR

FIGURE IV.I.5: SHADOWS ON JUNE 21 AT NOON



SOURCE: ESA, TICD, Turnstone Consulting

TREASURE ISLAND AND YERBA BUENA ISLAND REDEVELOPMENT PROJECT EIR

● **FIGURE IV.I.6: SHADOWS ON JUNE 21 AT 3PM**



SOURCE: ESA, TICD, Turnstone Consulting

TREASURE ISLAND AND YERBA BUENA ISLAND REDEVELOPMENT PROJECT EIR

● FIGURE IV.I.7: SHADOWS ON SEPTEMBER 21 AT 9AM



SOURCE: ESA, TICD, Turnstone Consulting

TREASURE ISLAND AND TERBA BUENA ISLAND REDEVELOPMENT PROJECT EIR

FIGURE IV.I.8: SHADOWS ON SEPTEMBER 21 AT NOON



SOURCE: ESA, TICD, Turnstone Consulting

TREASURE ISLAND AND YERBA BUENA ISLAND REDEVELOPMENT PROJECT EIR

● FIGURE IV.I.9: SHADOWS ON SEPTEMBER 21 AT 3PM



SOURCE: ESA, TICD, Turnstone Consulting

TREASURE ISLAND AND YERBA BUENA ISLAND REDEVELOPMENT PROJECT EIR

● **FIGURE IV.I.10: SHADOWS ON DECEMBER 21 AT 9AM**



SOURCE: ESA, TICD, Turnstone Consulting

TREASURE ISLAND AND TERBA BUENA ISLAND REDEVELOPMENT PROJECT EIR

FIGURE IV.I.11: SHADOWS ON DECEMBER 21 AT NOON



SOURCE: ESA, TICD, Turnstone Consulting

TREASURE ISLAND AND YERBA BUENA ISLAND REDEVELOPMENT PROJECT EIR

● **FIGURE IV.I.12: SHADOWS ON DECEMBER 21 AT 3PM**

Shadowing of Parks and Open Spaces

Shadowing of Existing Open Spaces and Recreation Areas

Shadow from the Proposed Project would reach into existing open spaces and recreation areas on Treasure Island and Yerba Buena Island. As noted previously, those existing areas are not under the jurisdiction of, or designated to be acquired by, the Recreation and Park Commission and are not subject to Section 295 of the Planning Code. This analysis examines shadow from the Proposed Project in order to determine whether that shadow would substantially affect the usability of those existing open spaces and recreation areas on the Islands.

The existing elementary school's playground areas would be modified and would become the School Open Space (#15 on Figure II.7). Whereas the existing playgrounds are not now shadowed by other buildings for most of the day throughout the year, the Proposed Project would result in shadowing that would reach into the area as early as 1 PM on the winter solstice and as early as 3 PM on the equinoxes. Thus, the playground areas would be in sunshine for most of the school day, throughout the school year, with new shadow reaching into the area during the afternoon. Shadow would reach into the area after 5 PM on the summer solstice, during summer vacation. Because the school playground areas would remain sunlit during their primary hours of use – during the school day during the autumn, winter, and spring and throughout the day during the summer – the shadows cast by the Proposed Project would not substantially affect their usability.

While the open grass fields and two basketball courts on the Job Corps campus that are located closer to 5th Street, near Avenue D, are in sunlight most of the time under existing conditions, shadow from some of the new high-rise towers of the Proposed Project would begin to reach into these southerly areas by 2 PM on the winter solstice. This tower shadow would not reach the grass area and baseball diamond adjacent to 9th Street. Between March and September, shadow from the Proposed Project would not reach the Job Corps campus recreation spaces until 6 PM or later. Job Corps campus recreation facilities would remain generally clear of Project shadow, except for the field and basketball courts closer to 5th Street. The presence of new mid-afternoon shadow during the winter is not likely to affect the usability of the basketball courts. However, even these facilities would be sunlit throughout the day during the spring, summer, and autumn, the seasons during which they are likely to be used the most. During the summer, neither the extent of shadow coverage nor the timing of the new shadow from the Proposed Project would substantially affect the usability of any of the existing open spaces and recreation areas on the Job Corps campus.

The only flat grassy open space on Yerba Buena Island is located on the Yerba Buena Road loop, near the peak of the island. Sunlight access to this open space is limited primarily by the topography of the island and the trees that surround the open space. Given that it is high on the

island and generally unobstructed to the east, west, and south, this open space can receive sunlight for much of the day, throughout the year. Proposed development surrounding the proposed Hilltop Park would be limited to 35 feet in height, with the exception of an 80-foot height limit to the east of the open space. These structures would not add substantial new shadow to Hilltop Park, since the 35-foot-tall structures are of heights similar to the existing trees that surround the present park area, and the 80-foot-tall building would be located east of Hilltop Park at a distance that would limit direct shadowing of Hilltop Park by that structure. Therefore, the shadow from the Proposed Project would not substantially affect the usability of Hilltop Park.

Shadowing of Parks and Open Spaces Proposed as Part of the Proposed Project

The Proposed Project would result in some shadowing on each of the planned parks and open spaces. The general sunlight and shadow conditions at each park and open space proposed in the Project Area are summarized in this section. Each park and open space noted in Figure II.7 is discussed below. In the following summaries, shadow or sunlight coverage descriptions are generalized and the times given are approximations, rounded to the nearest hour:

1 – Northern Shoreline Park

Except for the westernmost corner of this park, which would be partially shadowed until noon during the autumn and winter, the location of this proposed park and its separation from proposed buildings ensures that the Northern Shoreline Park would remain in sunlight all day, throughout the year.

2 – The Wilds

The northern half of this proposed area would be in sunlight most of the day throughout the year. The southern half of The Wilds would be shadowed beginning at 3 PM on the winter solstice and after 6 PM in March and September.

3 – Sports Park

The north side of this proposed park would have more sunlight than the south side, due to the buildings that form the southern boundary of this park. In March and September, the Sports Park would be in sunlight from about 9 AM until 6 PM. On the winter solstice, the southern half of the park would be in shadow until 10 AM, but would be in full sun until nearly 5 PM.

4 – Cityside Waterfront Park

Sunlight would cover most of the west-facing Cityside Waterfront Park from mid-morning until evening throughout most of the year. The buildings in the Cityside District would shadow this space in the early morning. As the sun rises, shadow from the buildings would retreat from the park, with most of the district's building shadow leaving the park about an hour before the shadows from the Cityside towers leave the park. The Cityside Waterfront Park would be clear of shadow by 11 AM every day.

5 – Eastern Shoreline Park and Pier 1

Sunlight would cover most of the east-facing Eastern Shoreline Park from sunrise until late afternoon throughout the year. On the winter solstice, shadow from the buildings in the Eastside District would begin to cover the southern part of this park after 11 AM, cover half

the park by 1 PM, and cover nearly the entire park by about 3 PM. On the spring and autumn equinoxes, shadow would begin to cover the southern part of this park after 3 PM. On the summer solstice, shadow would begin to cover this area after 7 PM.

6 – Urban Agricultural Park

The northern half of the proposed Urban Agricultural Park would be in sunlight from 9 AM until 2 PM on the winter solstice and from morning until nearly 5 PM on the equinoxes. Shadowing of this area would be due to adjacent Proposed Project buildings to the west.

The southern half of the proposed Urban Agricultural Park would be in sunlight most of the day throughout the year. Shadows from towers to the south and east would retreat by 10 AM on the winter solstice and on the equinoxes.

7 – Wetlands

The Wetlands would be located in the northern half of the proposed Wilds. As such, it would be in sunlight most of the day throughout the year.

8 – Eastside Commons

The north side of this proposed park would be in sunlight all day, year round. The south side of this area of the park would be in shadow during much of the day, throughout the year, due to the buildings that form the southern boundary of this linear open space. Most of the park would receive sunlight at some time every afternoon. By season, the most sunlight would reach into the Eastside Commons from 3 PM until 4 PM on the winter solstice, from noon until 4 PM on the equinoxes, and from 11 AM until 4 PM on the summer solstice.

9 – Cultural Park

Shadow would cover much of the west-facing Cultural Park during the early-morning hours. The park would be mostly in sunlight from mid-morning until late afternoon throughout the year. Most of the park area would be in sunlight from 9 AM until 3 PM on the winter solstice, from 9 AM until 5 PM on the equinoxes, and from 10 AM until 6 PM on the summer solstice. Shadows from various Proposed Project towers would reach portions of the Cultural Park at other times.

10 – Waterfront Plaza

This plaza would be open to the west and to the south. Two new buildings would be located to the east, and the existing Building 1 lies farther to the east of this linear plaza. With the Proposed Project in place, shadow on the south end of the Waterfront Plaza area would remain much as it is today, while morning shadowing would occur at the north end of the plaza. Otherwise, this west-facing open space would remain in sunlight for most of the day throughout the year.

11 – Building 1 Plaza

Building 1 Plaza would be open to the west and to the south. The existing Building 1 lies to the east of the plaza. Since the only project additions in this area would be small structures at the west end of the plaza, shadow with the Proposed Project would remain much as it is today. Except for the eastern portion of the plaza, which would be nearest to and shadowed by Building 1, this west-facing open space in front of Building 1 would remain in sunlight for most of the day throughout the year.

12 – Clipper Cove Promenade

Sunlight would cover this entire proposed south-facing park from early morning until late afternoon throughout the year. Shading would occur in the late afternoon during late spring and summer, when the days are longer. Shadowing of the Clipper Cove Promenade would not begin until after 5 PM on the summer solstice.

13 – Marina Plaza

The south side of this proposed plaza would be in sunlight and the north side of this plaza would be in shadow for much of the day during the autumn and winter due to the buildings to the east and the west. The south side of this area would be in sunlight substantially more, and for longer, than would the north side. Considered by season, the most sunlight would reach Marina Plaza from 10 AM until 2 PM on the winter solstice, from 11 AM until 5 PM on the equinoxes, and from 10 AM until 7 PM on the summer solstice.

14 – Cityside Neighborhood Park

Seven individual neighborhood parks would comprise Cityside Neighborhood Park. Nearby buildings that would front each of the seven individual neighborhood parks on the east, the north, and the west would shade much of the area of each park during most of the morning and from the mid-afternoon until sunset, throughout the year. Because the neighborhood parks open onto streets on the south, each park would receive the most sunlight at mid-day. Therefore, most of each park would receive sunlight at some time every day. The most sunlight would reach the park from noon until 1 PM on the winter solstice, from before noon until after 1 PM on the equinoxes, and from noon until 2 PM on the summer solstice.

15 – School Open Space

See description under “Shadowing of Existing Open Spaces and Recreation Areas,” p. IV.I.19.

16 – Habitat Management Plan Areas

Habitat Management Plan Areas would occupy the northern slope of Yerba Buena Island. Shadowing of these areas is due to the topography of the island and the existing groves of trees. The shadowing of these areas under the Proposed Project would be essentially the same as under the existing conditions.

17 – Hilltop Park

Hilltop Park would be an enlarged and reconfigured space on the site of the existing grassy area. The shadowing of this park would be essentially the same as shadowing of the existing grassy area, as described under “Shadowing of Existing Open Spaces and Recreation Areas,” p. IV.I.19.

18 – Senior Officers’ Quarters Historic District

The Senior Officers’ Quarters Historic District occupies a portion of the northeastern slope of Yerba Buena Island. Shadowing in these areas is currently due to the island’s topography and the existing trees. The shadowing of these areas under the Proposed Project would be essentially the same as under the existing conditions.

19 – Beach Park

Like the Habitat Management Plan Areas to the south, the proposed Beach Park would occupy the causeway and northern slope of Yerba Buena Island. Shadowing of this area is primarily due to the topography of the island and the existing groves of trees. The shadowing of Beach Park under the Proposed Project would be essentially the same as under the existing conditions.

Shadow Effects on the Usability of Proposed Parks and Open Spaces

Under the second significance criterion, an impact can result if a project shadow would substantially affect the usability of open space, outdoor recreation facilities, or other public areas. The effects of the above-described shadow conditions on the usability of each park, open space, and recreation area are evaluated as follows:

- The proposed Eastside Commons, Marina Plaza, and the seven sites of the Cityside Neighborhood Park would be urban parks, interspersed with nearby buildings and serving the residents and occupants. These parks gain their utility primarily from their proximity to users. Because the purpose of these parks is to provide small amounts of open space within an urban setting, they would be sited near buildings, where they would be partially or fully shadowed at various times of day. They would, however, receive the most sunlight exposure from late morning until early to mid-afternoon, times when use is expected to be highest. In small parks within urban settings, a mixture of sunlight and shadowing is to be expected; the anticipated extent of shadowing would not reduce the usability of these parks. Moving a park farther away from buildings might increase its sunlight exposure, but this would be expected to reduce its value, because it would be less accessible to users.
- The proposed Northern Shoreline Park, the Cityside Waterfront Park, the Eastern Shoreline Park and Pier 1, and the Clipper Cove Promenade would be perimeter parks and open spaces that would all have relatively small or essentially no shadowed areas at different times of day throughout the year. Taken together, they provide very large, open, sunlit areas that would be available any day of the year. Shadow on these areas by proposed buildings would be minimal and would not affect the usability of these perimeter parks and open spaces.
- The Building 1 Plaza, Waterfront Plaza, and the Cultural Park would serve varied public uses, but provide substantial areas of sunlit spaces, primarily from mid-morning through the rest of the day. Shadowing of these areas would occur in the mornings and would be relatively small. Shadow would not affect the usability of these plazas and this park.
- The School Open Space would be in sunlight during most of the school day throughout the year. Shadow would not affect its usability.
- The Urban Agricultural Park would be mostly in sunlight throughout the day during the spring and summer. During the autumn and winter, shadowing by adjacent Proposed Project buildings would occur in two different areas at two different times of day. Shadows from buildings to the west would reach the northern half of the park after mid-to late afternoon. Shadows from towers to the south and east would reach the southern half of the park in the early morning but would retreat by mid-morning. The additional

shadowing by the Project buildings during the autumn and the winter would not limit the ability to grow a wide range of agricultural crops in the Urban Agricultural Park.

- The Wetlands and the northern half of The Wilds would be in sunlight most of the day throughout the year. Portions of the southern half of The Wilds would be shadowed in the late afternoon during the autumn and winter by adjacent Project buildings to the south. However, both of these areas would receive essentially the same amount of sunlight that they receive under existing conditions. The additional shadowing by the Project buildings during the autumn and the winter would be relatively small and would not affect the health of the ecosystems of these areas.
- Habitat Management Plan Areas and Beach Park would occupy the northern slope of Yerba Buena Island. Shadowing of these areas is due primarily to the topography of the island and the existing groves of trees. The shadowing of these areas under the Proposed Project would be essentially the same as under the existing conditions and would not affect their usability.
- Hilltop Park and the Senior Officers' Quarters Historic District are local recreational areas that would receive a range of sunlight exposures throughout the day. The amount of sunlight that reaches the ground varies greatly across these areas, primarily due to existing trees. Both of these areas would receive essentially the same amount of sunlight as they receive under existing conditions.

As detailed above, the usability of each of the existing and proposed parks, open spaces, and recreation areas, including the proposed small urban parks that would be entirely in shadow at various times of the day, would not be substantially adversely affected by Proposed Project shadow. Thus, the impact of the Proposed Project under the second shadow impact significance criterion would be less than significant.

Summary

In summary, the Proposed Project would cast shadow on existing parks and open spaces, as well as on the parks and open spaces that are planned to be added as a part of the Proposed Project. The impact of these shadow effects is determined on the basis of the two significance criteria.

Under the first significance criterion, an impact can result from project shadow on existing parks or open spaces under the jurisdiction of, or designated to be acquired by, the Recreation and Park Commission. As discussed previously, all proposed open space in the Project Area would be owned and maintained by TIDA, and therefore the Proposed Project could not have adverse impacts related to shadowing under Planning Code Section 295.

Under the second significance criterion, an impact can result if a project shadow would substantially affect the usability of open space, outdoor recreation facilities, or other public areas. The effects of the Project shadow conditions on the usability of each were evaluated. As described in the "Shadowing of Parks and Open Spaces" section above, the usability of the existing and proposed parks, open spaces, and recreation areas would not be substantially affected

by shadow from the development of the Proposed Project. Thus, the impact of the Proposed Project under the second shadow impact significance criterion would be less than significant.

Based on evaluation against both shadow impact significance criteria, the shadowing by the Proposed Project would have a less-than-significant impact, and no mitigation measures would be required.

Cumulative Impacts

Impact WS-2: The Proposed Project, when combined with other cumulative projects, would not adversely affect the use of any park or open space under the jurisdiction of the Recreation and Park Commission or substantially affect the usability of other existing publicly accessible open space or outdoor recreation facilities or other public areas. (*Less than Significant*)

The cumulative development projects that could relate to the Proposed Project are (1) the construction and operation of a 400-berth marina in Clipper Cove (“Marina Project”), which was considered at a project level in the *Transfer and Reuse of Naval Station Treasure Island Final Environmental Impact Report* certified in 2005,² but has not yet been approved or constructed; and (2) the replacement of the existing on- and off-ramps from the Bay Bridge to the east side of Yerba Buena Island and the ongoing construction of the new east span of the Bay Bridge.

The marina’s landside improvements would be part of the Proposed Project. These landside improvements would shadow portions of the southern shoreline of Treasure Island. The cumulative shadow from the Proposed Project and the Marina Project, including the Marina Project’s waterside improvements that would cast almost no shadow, would be almost entirely due to the Proposed Project. The cumulative shadow from the Marina Project and the Proposed Project would be essentially the same as the shadow from the Proposed Project. As discussed above, the Proposed Project would have less-than-significant shadow impacts on existing and proposed parks, open spaces, and recreation areas.

The Yerba Buena Transition Structures and replacement on- and off-ramps for the new east span of the Bay Bridge would cast shadow on the nearby Senior Officers’ Quarters Historic District daily throughout the year. However, the only new shadow from the Proposed Project that would reach this area would be the shadow cast by components of the Proposed Project located within the Senior Officers’ Quarters Historic District. As a result, the Proposed Project’s contribution to cumulative shadow in this location, or in other locations on the east side of Yerba Buena Island, would be very small.

² *Transfer and Reuse of Naval Station Treasure Island Final Environmental Impact Report*, Planning Department Case No. 94.448, State Clearinghouse No. 1996092073, May 5, 2005. A copy of this document is available for public review at the San Francisco Planning Department, 1650 Mission Street, Suite 400, in Case File No. 2007.0903E.

IV. Environmental Setting and Impacts

I. Wind and Shadow

The new east span of the Bay Bridge includes a single 525-foot-tall suspension tower. Shadow from the tower will reach the southeast shoreline of Treasure Island, as far as the Eastside Commons, at 9 AM on the winter solstice. During the autumn and winter, the tower shadow will reach Treasure Island in the very early morning but recede by mid-morning and never substantially affect the usability of the existing and proposed parks, open spaces, and recreation areas. Shadow from the suspension tower could reach as far south as the Senior Officers' Quarters Historic District on Yerba Buena Island but only in the very early morning around the summer solstice. The shadow will recede before mid-morning and will not substantially affect the usability of this open space, thus resulting in a less-than-significant impact.

For these reasons, the Proposed Project would not combine with the other cumulative projects to create cumulatively considerable shadow impacts on existing or proposed parks, open spaces, and recreation areas. Therefore, mitigation measures would not be required.

I.2 WIND

This section describes the ground-level wind currents that would result from the construction of the Proposed Project. The potential ground-level wind effects were characterized based upon wind tunnel testing of a representative model of the Proposed Project and evaluation of the wind testing results. The report summarizing the wind testing results is attached as Appendix G to this EIR.

SETTING

Introduction

Winds result from the movement of air masses from a region of higher atmospheric pressure to a region of lower atmospheric pressure. The direction and speed of wind currents at the surface of the ground can be altered by natural features of the land or by buildings and structures.

The location of Treasure Island and Yerba Buena Island in the middle of the San Francisco Bay, between San Francisco and Oakland, fully exposes them to typical westerly winds and to strong storm winds from every direction. The speed and the turbulence of the wind that reaches the Islands are affected by the topography of the lands and the Bay that lies in its path. As winds move over the land, they encounter surface roughness and take on differing characteristics due to differing topography, vegetation, and structures that all act to slow the wind and to create turbulence. However, when winds reach large areas of smooth, flat surfaces, such as open land or the waters of the San Francisco Bay, the speed of the wind near that smooth surface will increase, and the level of turbulence in the wind will decrease.

At Treasure Island, approaching winds first encounter the dikes, ground surfaces, and low-rise development that now occupy much of the island; these features slow the winds that are closest to the ground, but have less effect on winds higher above the surface. Thus, winds on the shores of Treasure Island can be characterized as being similar to the winds over the surface of the Bay.

At Yerba Buena Island, wind approaching from any direction strikes only a fraction of the island's curved shoreline and rounded hillsides head-on; most of the approaching wind flow strikes the shoreline and hillsides at oblique angles and is diverted around the island. Stands of mature trees substantially shelter most existing developed areas. Although the higher elevations of Yerba Buena Island are exposed to winds of higher speed than occur at the surface of the Bay, the ground-level winds experienced by residents and visitors are highly localized and their magnitudes are determined by wind direction and the sheltering provided by the local topography and the many trees.

Effects of Tall Buildings on Wind

Tall buildings and large structures can strongly affect the wind environment for pedestrians. In cities, groups of structures tend to slow the winds near ground level, due to the friction and drag of the structures themselves. In general, the more densely spaced buildings in a downtown area will slow the winds near the ground.

However, a building that is much taller than the surrounding buildings, or that stands alone, can intercept and redirect winds that might otherwise flow overhead, and bring them down the vertical faces of the building to ground level, where they create ground-level wind and turbulence. These redirected winds can be relatively strong and relatively turbulent, and can be incompatible with the intended residential or commercial uses of nearby ground-level spaces. Moreover, high-rise structure designs that present tall flat surfaces that intercept strong winds can create ground-level winds that can be hazardous to pedestrians in the vicinity.

Thus, on one hand, clustered buildings in a downtown area can improve wind conditions at street level; on the other hand, taller buildings can cause wind problems for pedestrians. The condition that will prevail depends upon the details of the situation.

For development at Treasure Island, most of the proposed buildings would be more closely spaced, taller, and much larger than the existing, scattered low buildings they would replace. The Proposed Project would add clustered low-rise, mid-rise, and high-rise development to the island in the middle of the Bay. To confront the strong prevailing west wind, development along the avenues in the street grid would present barriers to the west wind, and the crossing streets are angled to prevent buildings from forming corridors aligned with the west wind.

Among the new buildings would be approximately 19 proposed high-rise towers. Any one of these towers would be large enough to cause ground-level wind problems for pedestrians, if it were to stand alone. Because the Proposed Project would include towers and because winds on Treasure Island are known to be strong, it is expected that the Proposed Project would result in substantial changes in street-level wind conditions over the developed area of the island.

Wind Speed and Pedestrian Comfort³

The comfort of pedestrians varies under different conditions of sun exposure, temperature, clothing, and wind speed. Winds up to 4 miles per hour (mph) have no noticeable effect on pedestrian comfort. With velocity from 4 to 8 mph, wind is felt on the face. Winds from 8 to 13 mph will disturb hair, cause clothing to flap, and extend a light flag mounted on a pole, while

³ Lawson, T.V. and A.D. Penwarden, "The Effects of Wind on People in the Vicinity of Buildings," Proceedings of the Fourth International Conference on Wind Effects on Buildings and Structures, London, 1975, Cambridge University Press, Cambridge, U.K., 605-622 1976.

winds from 13 to 19 mph will raise loose paper, dust, and dry soil, and will disarrange hair. For wind velocities from 19 to 26 mph, the force of the wind will be felt on the body. At wind speeds of 26 to 34 mph, umbrellas are used with difficulty, hair is blown straight, there is difficulty in walking steadily, and wind noise is unpleasant. Winds over 34 mph increase difficulty with balance, and gusts can blow people over.

Existing Wind Environment

Treasure Island and Yerba Buena Island are fully exposed to strong storm winds from every direction, and their direct exposure to the Golden Gate, approximately 6 miles to the west, also places them in the path of the strong regular afternoon winds generated by the combination of the large-scale climatic, meteorological, and topographic conditions in the Bay Area. The following descriptions of Bay Area climate and wind, Bay Area topography and winds, and Bay Area wind flows, which both paraphrase and directly quote from the Bay Area Air Quality Management District's *Climate, Physiography, and Air Pollution Potential – Bay Area and Its Subregions*,⁴ focus on the factors that materially affect the regular, strong winds that occur at Treasure Island and Yerba Buena Island, and help the reader understand why and how those winds differ from those winds that occur in downtown San Francisco or at the San Francisco International Airport.

Bay Area Climate and Wind

During the summer, the California coastal climate is dominated by the Pacific High, a semi-permanent high-pressure cell over the northeastern Pacific Ocean. This high, together with a thermal low over the Sonoran-Mojave Desert, causes northwest airflow along the coast and onshore winds over the San Francisco Bay Area during much of the summer. Marine air approaching the coast, already cool from its travel over the ocean, is further cooled as it crosses the very cold ocean waters that lie near the coast. This cold, dense marine layer of air is the major source of the stronger local summer winds in the Bay Area. During the winter, the Pacific High weakens and shifts southward, and winter storms become frequent, with occasional strong winds as storm fronts pass through the region. During winter rainy periods, winds are often moderate. When the Pacific High becomes dominant during the winter, temperature inversions⁵ become strong and often are surface-based; winds are light.

The Bay Area experiences stable atmospheric conditions. The inversion layer is typically about 1,500 feet above sea level and is usually created by subsidence, the heating of downward-moving air in the Pacific High. The marine inversion often moves lower in the afternoon during the

⁴ BAAQMD, *Climate, Physiography, and Air Pollution Potential - Bay Area and Its Subregions*, www.baaqmd.gov/dst/papers/bay_area_climate.pdf, accessed May 2009.

⁵ A temperature inversion occurs in the atmosphere when a layer of air is warmer than the layer of air that lies below it. Under normal atmospheric conditions, the air is heated from the ground up and the temperature of air decreases regularly as altitude increases.

summer; in July and August, it is frequently at 500 to 1,000 feet in the afternoon, but at 1,000 to 1,500 feet in the morning.

Bay Area Topography and Wind

San Francisco Bay Area terrain is complex. In the Bay Area, the northwest-southeast trending Coast Range is divided into western and eastern ranges, with the Bay between them. The Bay Area contains a sea-level pass through the Coast Range; the Golden Gate is the sea-level gap in the western range, and the Carquinez Strait is the sea-level gap in the eastern range. These two sea-level gaps allow air to flow relatively freely between the coast and the Central Valley, generally following a sinuous path over the intervening Bay and low lands that lie between the two gaps.

Ridges at elevations of 1,500 feet and higher in the eastern and western ranges of the Coast Range are high enough to distort surface wind flows through the Bay Area. The distortion is greatest when low-level inversions are present and the surface air flows independently from the air above the inversion. This is very common during the summer, when the surface air mass of the marine layer turns into the sea breeze.

Along the west side of the Bay are the Marin peninsula north of the Golden Gate and the San Francisco peninsula on the south. The mass of the Marin peninsula near the Golden Gate contains no significant gap. To the south, San Francisco is mostly below 200 feet, while the Santa Cruz Mountains extend up the center of the peninsula, with elevations of about 500 feet in South San Francisco and increasing to more than 2,000 feet at the south end. The marine layer can easily pass over much of low-lying San Francisco, as well as through the Golden Gate, resulting in high winds on the Bay and in San Francisco. Farther south, there are two important low-lying gaps along the Peninsula. The first is the San Bruno Gap, which extends from Fort Funston to the San Francisco International Airport. With ground elevations of less than 200 feet, this gap is oriented in the same direction as the prevailing northwest winds. The second is the Crystal Springs Gap, along State Route 92 between Half Moon Bay and San Mateo. The high point there is at 900 feet, compared with ridge elevations of 1,500 feet to the north and south. These two important low-lying gaps commonly allow the marine layer to pass across the Peninsula, resulting in high winds in certain areas on the east side of the Peninsula.

Along the east side of the Bay from Richmond through Oakland lie the Oakland-Berkeley Hills. With no gap and an approximate ridgeline height of 1,500 feet, these hills are a significant barrier to the flow of marine air.

Bay Wind Flows

Responding to the Bay Area climate and its topography, flows of marine air through the Golden Gate, across San Francisco, and through the San Bruno Gap are a dominant weather factor throughout the year. The Oakland-Berkeley Hills cause a split in the westerly flow in the vicinity of Oakland, with the air flow north of the Golden Gate moving northward and the air flow south of the Golden Gate moving southward. This divergence of the wind field results in diminished speed on the east side of the Bay, with a higher frequency of near-calm conditions than areas west of this split in the flow.

At the edge of the Bay, the US Naval Air Station, Alameda (NAS Alameda) is on the northern end of Alameda Island, some 2 miles southeast of the Bay Bridge. Due to its proximity to the Golden Gate, it represents the most marine zone of this East Bay climate sub-region. The wind regime at Oakland Airport, 10 miles southeast of the Bay Bridge, is very similar to Alameda's.

Wind Data Reference for Treasure Island

No useful long-term surface-level wind data appear to be available from a qualified meteorological station on Treasure Island. In the absence of a good wind record, data from a suitable substitute station can be used. From the above discussion, the speed and the direction of winds at Treasure Island are expected to differ from the speed and direction of winds in downtown San Francisco, Fort Funston and the San Francisco International Airport, all stations with qualified meteorological data.

Given the proximity to Treasure Island and the similar exposure to the Bay, the long-term wind record from NAS Alameda is considered to be a reasonable substitute for the unavailable Treasure Island wind record. However, it also appears that the winds at Treasure Island have a higher velocity than those measured at NAS Alameda, due to a combination of the longer fetch (the distance over which a wind blows) of open waters of the Bay to the west and a shorter fetch over flat land to the west. Each of these two factors tends to reduce the speed of the west winds that reach the NAS Alameda meteorological tower. However, the use of the NAS Alameda data, as adjusted to compensate for the speed differences, should provide a reasonable estimate of existing wind speeds on the island.

The directional shift in west winds as the airflow diverges in the East Bay is likely to mean that winds that occur at Treasure Island are rotated more to the north, compared to the direction of winds recorded at NAS Alameda. From an online review of historic wind direction data from the San Francisco Bay Wind Archives,⁶ the magnitude of this shift appears to vary with wind

⁶ SF Bay Wind Archives, <http://sfports.wr.usgs.gov/cgi-bin/wind/windarchive.cgi>, accessed September 2009.

direction, but appears to range from approximately 0 degrees to 10 degrees. For this analysis, which focuses on higher-speed winds, this directional shift appears too small to affect the results.

EXISTING DEVELOPMENT AND WIND CONDITIONS

Because there is existing development and vegetation on Treasure Island, street-level wind conditions on the island vary substantially by location, according to the amount of wind sheltering that is provided by the various types and densities of buildings and vegetation that now exist. As shown by the numerical results of the wind testing, the west is the dominant wind direction; therefore, the narrative bullets below describe existing development and wind exposures over major sections of the island – the northwest quadrant, the northeast quadrant, the central and the southern portions – but focus on the development along the western (upwind) edge of the island that would most affect these winds as they travel downstream:

- In the northwest quadrant of the Island, from the north end to 9th Street and from Perimeter Road to approximately 500 yards inland, development consists primarily of two-story buildings – most are multi-family residential buildings. Those closest to the Bay are generally grouped and aligned to face the Bay, placing the long side parallel to the shoreline. This exposes the Bay side to the prevailing winds and provides wind sheltering on the island side of the building. The pattern of development provides street-width openings for winds from the Bay. Because these buildings are 1) grouped together in six and eight residential units each, 2) oriented long side to the shore, 3) all of similar height, and 4) have few straight-through streets, they likely provide reasonable wind sheltering in the area. There is less sheltering on the leeward side of this residential area; wind speeds increase as they pass over vacant inland areas.
- In the northeast quadrant of the Island, scattered industrial buildings up to three stories in height occupy locations within the street grid, north of 9th Street between Avenue E and the eastern shore. These buildings appear to provide sheltering similar to that in the residential area to the west.
- In the central portion of the Island, between 9th Street and 4th Street, the area west of Avenue B is open space, while the area between Avenue B and Avenue D is occupied by large three- and four-story buildings, including the two four-story star-shaped structures west of the Job Corps, as well as the major Job Corps buildings. These buildings are interspersed with trees with canopies that reach above the buildings. These buildings and trees should provide good wind sheltering within the central part of this area. However, along 9th Street and 4th Street, the frontages are open parking lots that provide a 50-yard-wide opening for winds off the Bay, which can flow freely along these street corridors.
- In the central portion of the Island, the wind speed can increase as it passes over the baseball fields east of Avenue D.
- In the central portion of the Island, scattered industrial buildings up to three stories are located between 5th and 4th streets between Avenue D and the eastern shore. These appear to provide wind sheltering similar to the industrial area to the north.
- South of 4th Street, the southern portion of the Island is occupied by scattered large buildings up to five stories in height, substantial plantings of mature trees, as well as

Building 1 and the two more massive structures, Buildings 2 and 3, all of which are approximately 80 feet high. Together, these buildings and trees provide nearby wind sheltering; however, there are open areas that are sufficiently large enough to allow wind speeds to recover and increase.

- Due to topography and dense vegetative cover, any wind will affect primarily the windward side of Yerba Buena Island, but the primary effect is localized by the local topography and substantial sheltering provided by the stands of mature trees.

As a result, the speed of the incident wind from the Bay is materially reduced at street level by the two-story multi-family residential development as the wind reaches into the developed areas at the north end of Treasure Island. More substantial wind speed reductions occur in the more protected areas in the central and southern parts of the island. The diminished winds then increase again as they pass over vacant or open areas on the island. Once winds reach the east shore of the island and move over the water, wind speeds further increase, until they reach the east shore of the Bay. Regardless, the wind resistance (the surface roughness) of the existing development and vegetation on the island still reduces the speed of the surface wind to less than its speed over the vacant areas of the island, and to less than its speed over the open Bay.

The topography and dense vegetative cover of Yerba Buena Island determine ground level wind conditions in response to winds; any given wind primarily affects the windward side of the island, but the major effect at pedestrian level is highly localized and its magnitude determined by the sheltering provided by the local topography and stands of mature trees. Due to the structure of the winds in the atmosphere, the higher elevations on Yerba Buena Island are exposed to higher-speed winds than are lower elevations.

REGULATORY FRAMEWORK

In order to provide a comfortable wind environment for people in San Francisco, the City has established comfort and hazard criteria for use in evaluating proposed buildings. Section 148 of the Planning Code specifically outlines these criteria for the Downtown Commercial (C3) Districts; additional Planning Code sections apply the same criteria to the Rincon Hill, Van Ness Avenue, and South of Market areas. These Planning Code sections do not apply to properties on Treasure Island and Yerba Buena Island, and development there would not be subject to these sections of the Planning Code.

However, as stated on p. IV.I.35, the wind hazard criterion that is defined in Section 148 is used by the Planning Department as a significance threshold in the CEQA environmental review process to assess the environmental impact of projects throughout San Francisco and is therefore the basis of the analysis in this EIR. The following describes some details about Section 148 and the basis for this criterion:

IV. Environmental Setting and Impacts
I. Wind and Shadow

Planning Code Section 148 criteria are based on pedestrian-level wind speeds that include the effects of wind turbulence; these are referred to as “equivalent wind speeds” (defined in the Planning Code as “an hourly mean wind speed adjusted to incorporate the effects of gustiness or turbulence on pedestrians”).

Section 148 establishes equivalent wind speeds of 7 mph as the comfort criterion for seating areas and 11 mph as the comfort criterion for areas of substantial pedestrian use, and states that new buildings and additions to buildings may not cause ground-level winds to exceed these levels more than 10 percent of the time year round between 7:00 AM and 6:00 PM. Section 148 also establishes a hazard criterion, a 26 mph equivalent wind speed for a single full hour of the year.

Under Section 148, new buildings and additions (within specific areas of San Francisco) may not cause wind speeds that meet or exceed this hazard criterion,⁷ and no exception may be granted to construct buildings that result in winds that exceed the hazard criterion. As Section 148 does not apply to Treasure Island or Yerba Buena Island and therefore does not apply to the Proposed Project, the CEQA impact analysis significance threshold is based on the hazard criterion defined in Section 148 and is therefore the basis of the analysis in this Section. The measured equivalent wind speeds that were exceeded 10 percent of the time year round between 7:00 AM and 6:00 PM are provided here for informational purposes; this information relates to the Section 148 pedestrian comfort criterion and is commonly reported in San Francisco EIRs; however, the Section 148 comfort criterion is not used to evaluate the significance of wind impacts.

The Section 148 comfort criteria are based on wind speeds measured and averaged over one minute, the same averaging time as the weather bureau wind data. In contrast, the hazard criterion is defined by a wind speed that is measured and averaged over one hour; when stated on the same time-basis as the comfort criteria wind speeds, the hazard criterion wind speed (26 mph for a full hour) is a 1 minute average wind speed of 36 mph.^{8,9}

⁷ Because the Section 148 hazard criterion is stated in terms of 1 hour of exceedance, it is most appropriate to report exceedances of this hazard criterion in terms of the number of hours per year that the excess occurs, rather than the accompanying wind speeds. Note that the hazard criterion applies to any speed of 26 mph or greater, and does not distinguish between a one hour exceedance with a speed of 27 mph and a one hour exceedance with a speed of 28 mph. Thus, for each wind analysis, the number of locations and the total sum of the durations of exceedances of the hazard criterion are the important measures of impact. This differs from reporting of Section 148 comfort criteria, for which wind speeds exceeded 10 percent of the time are examined and presented, but statistics other than the number of exceedances may not be detailed.

⁸ Arens, E; Ballanti, D; Bennett, C.; Guldman, S.; White, B., “Developing the San Francisco Wind Ordinance and its Guidelines for Compliance,” Building and Environment, Vol. 24, No. 4, p. 297-303, 1989.

⁹ The speed of the wind normally varies substantially over an hour. Gusts add to the average speed and lulls reduce it. The measured wind speed depends upon the averaging time over which the measurement is made. In general, the longer the averaging time, the lower the speed measured. The Section 148 wind

If wind testing of proposed buildings is necessary, it is performed according to test protocols agreed to by the Planning Department.¹⁰ The protocols include, among other things, defining the extent and content of the wind test model, the elements to be included in each wind test scenario, the test point locations, and the use of the wind speed profiles¹¹ that apply to the test site, so that the scaling of the wind tunnel test results will be correct.

IMPACTS

SIGNIFICANCE CRITERIA

The City and County of San Francisco has not formally adopted significance thresholds¹² for impacts related to wind. Rather, the Planning Department's Initial Study Checklist form provides a framework of topics to be considered in evaluating potential impacts under CEQA. The checklist directs the City to consider whether the project would "[a]lter wind in a manner that substantially affects public areas." The City analyzes this by determining whether the project could have a potentially significant impact related to wind, which would occur if it were to:

- Increase the number of hours that the Section 148 wind hazard criterion is exceeded or increase the area subjected to wind hazards.

To assess whether a project would result in a significant impact under this criterion, the City uses the Planning Code's hazard criterion; that is, it determines whether a project would cause equivalent wind speeds to reach or exceed the wind hazard level of 26 mph for a single hour of the year. If a project would cause a wind hazard or add to an existing wind hazard in a public

hazard criterion was based on research that identified a 3-second gust of wind at 44 mph (20 m s⁻¹) as being strong enough to destabilize pedestrians. Starting with this value and using an appropriate wind speed distribution, the following wind speeds characterize the "same" hazardous wind, as it can be characterized for each of three averaging times. Each interval could contain the hazardous wind event:

<u>Averaging time</u>	<u>Speed</u>	<u>Note</u>
1 hour	26 mph	one-hour average wind speed
1 minute	36 mph	Weather Bureau one-minute average wind data
3 seconds	44 mph	mean velocity of highest 3-second gust

Exceeding the wind hazard criterion requires more than one full hour of wind averaging 26 mph. For convenience and consistency in reporting and comparing tested wind speeds, the 1-minute average speeds are used here: 1) to compare with the 36 mph value for the hazard criterion; and, 2) to report wind speeds exceeded 10 percent of the time. They are more appropriate for discussions of general wind conditions.

¹⁰ Section 148(c). Procedures and Methodologies for implementing this section shall be specified by the Office of Environmental Review of the Department of City Planning. (Added by Ord. 414-85, App. 9/17/85)

¹¹ The wind speed profile measures velocity as a function of height above the surface of the ground (or water). The speed of the wind increases more rapidly with height above smooth surfaces and more slowly above very rough surfaces, such as a city. The smoother the surface, the more quickly the wind speed increases with height above that surface. Each location in the City has a wind speed profile that describes the characteristics of the wind there.

¹² Under *CEQA Guidelines* Section 15064.7, a lead agency may, but is not required to, formally adopt thresholds of significance for general use.

area, it would thereby result in a significant impact, because the project would result in hazardous wind conditions for pedestrians.¹³ The City requires mitigation measures to avoid the wind hazard or the increase in wind hazard.

If a project were to cause winds that would exceed Section 148 comfort criteria, but would not cause a wind hazard or add to a wind hazard, the project's impact would not be considered significant, because such winds would not result in hazardous conditions for pedestrians.

WIND TEST ANALYSIS

Wind tunnel testing was conducted for the Proposed Project. Tests were performed for the existing setting condition and for the Project scenario. Although the Proposed Project would include development on both Treasure Island and Yerba Buena Island, the changes in pedestrian level wind conditions on Yerba Buena Island due to the Proposed Project are generally expected to be both relatively small in magnitude and highly localized to individual building sites, compared to the larger scale and larger magnitude changes anticipated to occur on the more extensive development on Treasure Island. The testing therefore focused on Treasure Island and the pedestrian wind environment that would exist within the proposed development there.

For the wind testing, the existing setting consisted generally of the existing buildings on and in the vicinity of the Development Plan Area that would remain after site redevelopment. These included the existing elementary school in the north, the Job Corps buildings in the center, and Buildings 1, 2 and 3 in the south of the island. In addition, the two existing four-story star-shaped structures west of the Job Corps site were also considered as part of the existing setting.

The Project scenario that was tested consisted of a representative massing for the Proposed Project added to the existing buildings that would remain after site redevelopment on Treasure Island. The Proposed Project would involve construction of many separate building clusters with buildings ranging in height from approximately 35 to 650 feet. The Proposed Project would include construction of up to 19 high-rise towers, among a substantial base of low- and mid-rise buildings, on Treasure Island.

Five wind directions were tested for each scenario: north-northwest, northwest, west-northwest, west, and south-southeast. Twenty-nine (29) test points were measured to characterize the existing setting. Given the relatively uniform level of development on the island, a relatively uniform wind field exists over most of the surface area of the Island. Therefore, these 29 points were judged to be sufficient to characterize that existing wind environment. For the Project scenario, wind speeds were measured at 200 locations within the Project and vicinity; the larger

¹³ Note that Section 148 criteria normally apply to public areas that are open and accessible to the public, such as sidewalks, streets, as well as public parks and open spaces. However Section 148 criteria are not applied to private open spaces, service areas, and non-public areas on project sites.

number of test points was needed to show wind conditions on sidewalks, streets, parks, and open spaces throughout Proposed Project at a sufficient level of detail. The test points on the premises of the Proposed Project site are scattered among all of the buildings and building clusters, with several points located on the perimeter of the island (see Figure IV.I.13a: Test Point Locations – Proposed Project North Portion Detail, and Figure IV.I.13b: Test Point Locations – Proposed Project South Portion Detail). Of the 29 Existing Setting test points, six points (#1 – #6) were sited around buildings that would be demolished, so they were not measured under the Project scenario; the remaining 23 Existing Setting test points (#7 – #29) were measured for the Project scenario, to provide a basis for comparison.¹⁴

Special attention was paid in locating the test points to provide information about wind conditions in identified parks and open spaces, as well as along streets and pedestrian thoroughfares. For narrative purposes in identifying test point locations, Figures IV.I.13a and IV.I.13b, pp.IV.I.39 and IV.I.41, respectively, show arbitrary street names¹⁵ for the Proposed Project. In the narratives, some of the test points are considered more than once, since this provides useful information about wind flows along streets.

The test points were selected because they are located in areas where measurable effects caused by the Proposed Project would reasonably be anticipated. Some points are located at building corners and on roadways and pathways that run between the buildings. Care was taken to trace turbulent winds that could originate from the 19 high-rise towers that are a part of the Proposed Project.

Table IV.I.1: Wind Speeds Exceeded 10 Percent of the Time – Existing and Proposed Project, presents the analysis results for the measured equivalent wind speeds that were exceeded 10 percent of the time for each test location and test scenario and the percentage of time that the wind speed would exceed the pedestrian comfort criterion.¹⁶ Table IV.I.2: Wind Hazards – Existing and Proposed Project, presents the wind hazard analysis results, the equivalent wind speed, and the number of hours per year that the hazard criterion would be exceeded for each test location and test scenario.

The following narrative makes comparisons between the existing and Project wind conditions, based on the measured winds at these 23 locations and presented in Tables IV.I.1 and IV.I.2.

¹⁴ The measurement points in Figures IV.I.13a and IV.I.13b are color-keyed as follows: 1) points #1 through #6 are in green numerals on rectangular white fields; 2) points #7 – 29 are in white numerals on rectangular green fields; and, 3) points #30 – 206 are in black numerals on rectangular white fields.

¹⁵ Some names are taken from the draft *Design for Development*, while others were arbitrarily assigned for convenience in the narrative; all names are subject to change.

¹⁶ Although neither the Section 148 pedestrian comfort criterion or the seating comfort criterion are used as a CEQA significance threshold, the analysis and discussion of winds exceeded 10 percent of the time provides the reader with a basis for comparison with these familiar wind hazard and wind comfort criteria.

IV. Environmental Setting and Impacts
I. Wind and Shadow

Table IV.I.1: Wind Speeds Exceeded 10 Percent of the Time – Existing and Proposed Project¹

References		Existing			Proposed Project			
Test Location Number	Wind Comfort Criterion Speed, miles/hour	Equivalent Wind Speed Exceeded 10%	Percent of Time Wind Speed Exceeds	SOURCE (by type)	Equivalent Wind Speed Exceeded 10 Percent of Time, miles/hour	Percent of Time Wind Speed Exceeds Criterion	Speed Change Relative to Existing, miles/hour	SOURCE (by type)
		Percent of Time, miles/hour						
1	11	18	35	e				
2	11	16	26	e				
3	11	19	29	e				
4	11	16	24	e				
5	11	12	14	e				
6	11	16	27	e				
7	11	19	35	e	15	24	-4	e
8	11	16	27	e	10	8	-5	-
9	11	18	30	e	14	19	-4	e
10	11	19	34	e	15	24	-4	e
11	11	18	33	e	10	6	-8	-
12	11	16	29	e	19	32	4	e
13	11	20	32	e	9	6	-10	-
14	11	17	26	e	12	16	-4	e
15	11	16	24	e	9	3	-7	-
16	11	16	30	e	10	8	-6	-
17	11	14	21	e	8	2	-6	-
18	11	15	24	e	15	27		e
19	11	17	32	e	13	16	-4	e
20	11	11	9		10	7		
21	11	19	36	e	11	11	-8	-
22	11	14	21	e	10	7	-5	-
23	11	16	25	e	11	9	-6	-
24	11	17	33	e	15	28	-2	e
25	11	18	33	e	16	27	-3	e
26	11	16	27	e	14	23	-2	e
27	11	17	33	e	12	12	-6	e
28	11	15	28	e	12	13	-3	e
29	11	10	6		13	16	3	p
Ave. of 10%	Percent:	16.2 mph	27%		12.3 mph	15%	-3.9 mph	
Total Exceedances:		Total	27		Total	13		
<i>Subtotals by type:</i>		<i>Existing</i>	27	e²	<i>Existing</i>	12	e²	
					<i>New, due to Proposed Project</i>	1	p³	
					<i>New, at new location</i>	0	n⁴	
					<i>Eliminated by Proposed Project</i>	9	-⁵	

Note:

¹ Tabular Values are rounded to the nearest integer. What may appear to be discrepancies in the tabular results, such as in the column sums or the differences between values for project and existing conditions, are simply due to the rounding of results.

² “e” = an existing comfort exceedance

³ “p” = a new comfort exceedance that is due to an increase in the equivalent wind speed and/or an increase in the percentage of time that the comfort criterion is exceeded

⁴ “n” = a new comfort exceedance in a location that did not previously have a comfort exceedance

⁵ “-” = an existing comfort exceedance that would be eliminated by the Proposed Project

Source: Environmental Science Associates



SOURCE: ESA

TREASURE ISLAND AND TERDA PUENA ISLAND REDEVELOPMENT PROJECT EIR

FIGURE IV.I.13a: TEST POINT LOCATIONS - PROPOSED PROJECT NORTH PORTION DETAIL



SOURCE: ESA

TREASURE ISLAND AND YERBA BUENA ISLAND REDEVELOPMENT PROJECT EIR

FIGURE IV.I.13b: TEST POINT LOCATIONS - PROPOSED PROJECT SOUTH PORTION DETAIL

IV. Environmental Setting and Impacts
I. Wind and Shadow

Table IV.I.2: Wind Hazards – Existing and Proposed Project¹

References		Existing			Proposed Project			
Test Location Number	Wind Hazard Criterion Speed, miles/hour	1-hour/year Equivalent Wind Speed, miles/hour	Wind Hazard Criterion Exceeded, hours/year	SOURCE (by type)	1-hour/year Equivalent Wind Speed, miles/hour	Wind Hazard Criterion Exceeded, hours/year	Hazard Hours Change Relative to Existing	SOURCE (by type)
1	36	40	5	e				
2	36	41	7	e				
3	36	44	11	e				
4	36	37	1	e				
5	36	27						
6	36	41	8	e				
7	36	41	6	e	34		-6	-
8	36	41	4	e	23		-4	-
9	36	42	7	e	32		-7	-
10	36	42	7	e	34		-7	-
11	36	39	3	e	22		-3	-
12	36	34			45	15	15	p
13	36	44	12	e	33		-12	-
14	36	38	3	e	28		-3	-
15	36	37	1	e	19		-1	-
16	36	42	9	e	29		-9	-
17	36	38	3	e	17		-3	-
18	36	43	12	e	41	7	-5	e
19	36	37	1	e	29		-1	-
20	36	24			23			
21	36	41	10	e	25		-10	-
22	36	37	2	e	22		-2	-
23	36	37	8	e	23		-8	-
24	36	37	2	e	36		-2	-
25	36	41	7	e	35		-7	-
26	36	34			30			
27	36	38	2	e	28		-2	-
28	36	33			26			
29	36	35			28			
Ave. 1-hr:	Total hrs:	38 mph	131 hr		29 mph	22 hr	-77 hr	
Total Exceedances:		Total	23		Total		2	
<i>Subtotals by type:</i>		<i>Existing</i>	23	e	<i>Existing</i>		1	e²
					<i>New or increased time</i>		1	p³
					<i>New, at new location</i>		0	n⁴
					<i>Eliminated by Proposed Project</i>		17	-⁵

Note:

¹Tabular Values are rounded to the nearest integer. What may appear to be discrepancies in the tabular results, such as in the column sums or the differences between values for project and existing conditions, are simply due to the rounding of results.

²“e” = an existing hazard exceedance

³“p” = a new hazard exceedance that is due to an increase in the equivalent wind speed and/or an increase in the number of hours that the hazard criterion is exceeded

⁴“n” = a new hazard exceedance in a location that did not previously have a hazard exceedance

⁵“-” = an existing hazard exceedance that would be eliminated by the Proposed Project

Source: Environmental Science Associates

Existing Setting Wind Speeds and Hazards

The average of the existing wind speeds that would be exceeded only 10 percent of the time calculated from measurements at the 29 existing test points is over 16 mph; measured wind speeds range from 10 to 20 mph. The highest existing wind speed measured in the test (20 mph) occurs at the south end of the southernmost Job Corps building. Two (2) of the 29 points meet the pedestrian-comfort criterion of 11 mph under existing conditions; one of these (#20) is located at the north entrance to Building 3 and one (#29) in the yard of the existing school.

The wind hazard criterion of Planning Code Section 148 is currently exceeded at 23 of the 29 test locations under existing conditions. In addition, given the uniformity of the wind field over the island, it is reasonable to assume that the wind hazard criterion is currently exceeded at a very large number of other locations on the island.

Proposed Project Wind Speeds and Hazards Compared to Existing Conditions

With the Proposed Project, wind conditions at the outer edges of the built areas would remain very windy, while wind speeds at sidewalk, street, park and open space locations within the interior of the development would generally decrease. The average of the measured wind speeds that would be exceeded 10 percent of the time for the 23 common test points would be less than 12 mph, a decrease of nearly 5 mph compared to the existing condition. Wind speeds at the common test points would range from 8 to 19 mph, with 13 of the 23 points meeting the Planning Code's pedestrian-comfort criterion. Nine existing exceedances of the pedestrian-comfort criterion would be eliminated, one new exceedance would be created, and 12 existing exceedances would remain, while one point that meets the pedestrian-comfort criterion under existing conditions would continue to do so with the Proposed Project.

With the Proposed Project, as compared to existing conditions, wind speeds would increase at two locations; remain unchanged at two locations; and decrease at 19 of the 23 locations. Wind speed increases would range up to 4 mph; wind speed decreases would range up to 10 mph. The highest wind speed that would be exceeded 10 percent of the time (19 mph) would occur at Test Point 12, located at the south end of an existing Job Corps building that fronts on Avenue C.

With the Proposed Project, the Planning Code's wind hazard criterion would be exceeded at 2 of the 23 common test locations; this would be a substantial reduction compared to the 19 existing hazards at those 23 common locations. However, as is the case for existing wind conditions, it is reasonable to assume that the wind hazard criterion would continue to be exceeded at many other exposed open area locations on the island.

Review of Project Test Results

The analysis of all 200 test point locations yields basic information about the general wind conditions that would occur on Treasure Island following the construction of the Proposed Project.

While the general wind conditions and trends discussed here result partly from the overall configuration and massing of development, the specific wind speed and/or hazard that would occur at any test location is strongly influenced by the nearby structures as part of that overall development. The details of these results come from wind testing a specific model design - the representative massing model of the Proposed Project. Thus, the wind test produced results that are specific to that design. However, the Proposed Project would allow for some flexibility in the shape and precise location of the towers; tower volumes may change as specific building designs are proposed. Although different building configurations will result in different ground-level wind effects, some changes in building configurations would produce minor differences in wind conditions while others could produce major differences in wind conditions.

Of the 200 Project locations that were tested in the wind tunnel, wind hazard conditions were detected at 49 locations, as shown in Figure IV.I.14: Wind Hazard Locations and Hours Durations for Representative Massing of Proposed Project. The image shows the overall distribution of the wind hazards around and within the Development Plan Area. This overall perspective is helpful in understanding the street-by-street and open space discussions that follow.

In general, the incidence of wind hazards would be higher along the Proposed Project's outer edges, and the relative frequency of wind hazards generally would diminish in the interior of the Proposed Project. Notable exceptions would occur in those interior areas that are: open and directly exposed to winds from the Bay, exposed to the effects of tall buildings, or exposed to strong incident winds channeling between building masses and along the streets.

Review of Street-by-Street and Open Space Effects

The following summarizes the wind conditions that would exist within the Proposed Project, given that the study used a proposed representative height and massing design to represent the Proposed Project in the wind-tunnel. That bulk model was tested to evaluate likely effects that the Proposed Project would have on the street-level wind conditions on streets and within pedestrian areas of the development, in existing recreation areas, and in the proposed locations of planned parks and open spaces. It is not necessary to discuss all of the test points in order to understand the overall wind performance of the representative design.



SOURCE: ESA

Review of Project Wind Conditions – Street by Street

A street-by-street summary of Project wind conditions¹⁷ on public sidewalks, streets, parks and open spaces starts with the westernmost street, Cityside Avenue, and moves eastward along the parallel avenues and alleys to Eastside Avenue, as follows:

- **Cityside Avenue** – (16 test points: # 78, 79, 88, 89, 90, 98, 99, 108, 109, 117, 118, 119, 127, 128, 129, 139) Cityside Avenue is located at the western edge of the Proposed Project and is directly exposed to winds from the Bay. Along Cityside Avenue, wind speeds would range from 11 to 19 mph. Winds at only one (#127) of the 16 locations would meet the pedestrian comfort criterion. Winds at five of the 16 locations (#78, 79, 98, 99, 118) would exceed the wind hazard criterion. Their hazard durations would range from 1 to 10 hours per year.
- **Cityside Alley** – (18 test points: 76, 77, 80, 81, 86, 87, 91, 92, 96, 97, 100, 101, 105, 106, 107, 110, 111, 112, 115, 116, 120, 130, 131, 135, 136, 137, 138) Along Cityside Alley, wind speeds would range from 8 to 17 mph, with wind speeds lower in mid-block sections. Wind speeds would be highest at 10th Street, near the north end of the development. The Cityside Neighborhood Park sites at 5th Street (#115, 116), at 6th Street (#105, 106) and at 7th Street (#96, 97) would have 10 percent exceeded speeds ranging from 10 to 12 mph. Wind speeds would be 13 mph at the Cityside Neighborhood Park site at 9th Street (#76, 77). Wind hazards would occur at four of the 18 locations along Cityside Alley (#80, 81, 135, 137); two wind hazards would occur at 10th Street, with durations of 2 and 15 hours per year, and two would occur at the east side of Cultural Park, with durations of 1 and 10 hours per year.
- **Avenue C** – (38 test points: #7, 8, 10-12, 14, 18, 45, 46, 55-57, 65, 66, 72, 74, 75, 82-85, 93-95, 102-104, 113, 114, 121-124, 132-134, 145-147) Along Avenue C, wind speeds would range from 8 to 19 mph. Winds at 11 of the 38 locations (#8, 11, 45, 65, 83, 95, 122, 123, 124, 132, 133) would meet the pedestrian comfort criterion. Wind speeds would be higher at 10th Street, at the north end of the development, and in the central area, near California Avenue. Wind speeds would remain higher in the Job Corps area, where existing wind speeds are already higher. Wind hazards would occur at 12 of the 38 test points (#12, 18, 46, 82, 93, 102, 123, 132, 133, 134, 145, 147) along Avenue C. These wind hazards would occur with individual durations ranging from 1 to 56 hours per year.
- **Avenue C Alley** – (10 test points: #44, 47, 53, 54, 58, 63, 64, 67, 68, 69) Along Avenue C Alley, wind speeds would range from 7 to 14 mph. Winds at six of the 10 locations (#53, 58, 63, 64, 67, 68) would meet the pedestrian comfort criterion. The two Cityside Neighborhood Parks located along this alley, one at 7th Street (#63, 64) and one at 8th Street (#53, 54) would have 10 percent exceeded speeds ranging from 8 to 12 mph. A single wind hazard, with a duration of 1 hour per year, would occur at 10th Street (#47).
- **Avenue D** – (23 test points: #18, 32, 33, 34, 40, 41, 43, 49, 50, 51, 52, 60, 61, 62, 70, 142, 143, 144, 149, 153, 154, 200, 203) Along Avenue D, wind speeds would range from 8 to 20 mph. Wind speeds would vary along this roadway, with the highest wind speeds occurring at the south end, between 1st and 3rd streets, and relatively lower wind speeds occurring between 3rd and 9th Streets. Winds at 10 locations (#32, 33, 40, 41, 43, 50, 51, 61, 62, 70) would meet the pedestrian comfort criterion. Wind hazards would occur at

¹⁷ See Figures IV.I.13a and IV.I.13b for the locations of the test points.

eight of 23 test points along Avenue D. One wind hazard, with a duration of 1 hour per year, would occur at 8th Street (#52). The other seven, with individual durations ranging from 2 to 50 hours per year, would occur between 1st Street and 4th Street (#18, 142, 149, 153, 154, 200, 203).

- **Avenue D Alley** – (four test points: #35, 36, 39, 42) Along Avenue D Alley, wind speeds would range from 5 to 10 mph, so all locations would meet the pedestrian comfort criterion. No wind hazard would occur.
- **Avenue E** – (13 test points: #19, 30, 31, 37, 38, 150, 151, 156, 157, 158, 160, 161, 201) Along Avenue E, wind speeds would range from 8 to 18 mph. Winds at four of the 13 test point locations (#31, 37, 38, 150) would meet the pedestrian comfort criterion. Wind hazards would occur at two locations, one at 8th Street (#30) and one between 3rd and 4th streets (#157), with individual durations of 6 and 2 hours per year, respectively.
- **Avenue H** – (eight test points: #20, 155, 159, 165, 166, 167, 170, 171) Along Avenue H, wind speeds would range from 10 to 15 mph. Winds at a total of three locations (#20, 167, 170) would meet the pedestrian comfort criterion. Wind hazards would occur at two of the eight test point locations on Avenue H, at 3rd Street, with individual durations of one hour per year (#165) and 17 hours per year (#171).
- **Avenue I** – (11 test points: #21, 22, 163, 164, 168, 169, 174, 175, 178, 179, 199) Along Avenue I, wind speeds would range from 10 to 17 mph. Winds at seven of these locations (#21, 22, 164, 169, 174, 178, 199) would meet the pedestrian comfort criterion. A wind hazard, with a duration of 2 hours per year, would occur at Avenue I and 4th Street (#163).
- **Avenue J** – (seven test points: #172, 173, 176, 177, 183, 184, 186, 187) Along Avenue J, wind speeds would range from 9 to 15 mph. Winds at four of the locations (#173, 176, 177, 186) would meet the pedestrian comfort criterion. A wind hazard, with a duration of one hour per year, would occur on Avenue J between 3rd and 4th streets (#184).
- **Avenue K** – (eight test points: #180, 181, 182, 185, 192, 196, 197, 198) Along Avenue K, wind speeds would range from 9 to 18 mph. Winds at three of the locations (#181, 185, 196) would meet the pedestrian comfort criterion. Wind hazards would occur at five of the test point locations (180, 182, 192, 196, 198) along Avenue K between 2nd and 4th streets, with individual durations of 1 to 6 hours per year.
- **Eastside Avenue** – (six test points: #189, 190, 191, 193, 194, 195) Along Eastside Avenue, which is at the eastern edge of the Proposed Project and is directly exposed to winds from the north and south, wind speeds would range from 10 to 18 mph. Winds at three locations (#190, 191, 193) would meet the pedestrian comfort criterion. Wind hazards would occur at the other three test point locations along Eastside Avenue, at both the north and south ends of the street, with individual durations of 1, 4, and 4 hours per year.

Review of Project Wind Conditions – Parks and Open Spaces, Job Corps

Strong existing winds and their accompanying higher incidence of wind hazards now occur and would continue to occur in the exposed shoreline parks and open spaces; the Proposed Project would not affect these wind conditions. Only those parks and open spaces that are within the interior of the Development Plan Area show any wind effect that can be attributed to the

Proposed Project. The following summarizes wind conditions in some of the public Parks and Open Spaces, as well as in the Job Corps area, with Project development:¹⁸

- **Building 1 Plaza** – (three test points: #26, 27, 141) The wind speeds exceeded 10 percent of the time at the three test points would range from 14 to 16 mph. No wind hazard would occur at these locations.
- **Building 2** – (three test points: #18, 19, 203) Wind speeds at these three test points would range from 13 to 15 mph. Wind hazards would occur at two of the three locations, with individual durations of 7 hours per year (#18) and 50 hours per year (#203).
- **Building 3** – (four test points: #20, 21, 22, 23) Wind speeds at these four locations would range from 10 to 11 mph; winds at all of these locations would meet the pedestrian comfort criterion. No wind hazards would occur.
- **Cityside Neighborhood Park** – (12 test points: # 53, 54, 63, 64, 76, 77, 96, 97, 105, 106, 115, 116) Wind speeds at these 12 test points would range from 8 to 13 mph. Winds at five of the 12 locations (#53, 63, 64, 97, 105) would meet the pedestrian comfort criterion. No wind hazards would occur.
- **Cultural Park** – (four test points: # 135, 136, 137, 138) Wind speeds at these four test points would range from 13 to 17 mph. Wind hazards would occur at two of the four locations, with durations of 1 hour per year (#135) and 10 hours per year (#137).
- **Cityside Waterfront Park** – (two test points: #205, 206) The wind speeds exceeded 10 percent of the time would range from 16 to 17 mph. Winds at both locations would exceed the wind hazard criterion. The durations of the individual hazards would be 3 hours per year and 4 hours per year, at locations #206 and 205, respectively.
- **Clipper Cove Promenade** – (two test points: #202, 204) Wind speeds would range from 11 to 15 mph. Wind at one of the two locations (#202) would meet the pedestrian comfort criterion. No wind hazard would occur.
- **Eastside Commons** – (21 test points: #151-153, 156, 161, 162, 164-166, 168, 171, 173, 174, 176, 182, 183, 187, 191, 193, 198, 201) Wind speeds would range from 10 to 20 mph. Winds at six of the 21 locations would meet the pedestrian comfort criterion (164, 173, 174, 176, 191, 193). Wind speeds would vary by block along the Eastside Commons – winds would be higher between Avenue D and Avenue H, lower between Avenues I and J, higher at Avenue K, and lower at Eastside Avenue.

Winds at five of the 21 test points (#153, 165, 171, 182, 198) in the Eastside Commons would exceed the wind hazard criterion. Hazards would occur: at two locations at Avenue H and 3rd Street for durations of 1 hour per year (#165) and 17 hours per year (#171); at two locations at Avenue K and 3rd Street (#182, 198) for durations of 2 hours per year each; and, at one location at 3rd Street, California Avenue, and Avenue D (#153) for a duration of 14 hours per year.
- **Marina Plaza** – (two test points: #24, 25) Wind speeds would range from 15 to 16 mph. No wind hazard would occur.
- **School Open Space** – (one test point: #29) Wind speed would be 13 mph. No wind hazard would occur.

¹⁸ See Figures IV.I.13a and IV.I.13b for the locations of the test points.

- **Waterfront Plaza** – (three test points: #125, 126, 140) Wind speeds in this exposed waterfront location would range from 13 to 19 mph. Winds at all three test points would exceed the wind hazard criterion. The hazard durations would range from 1 to 10 hours per year.
- **Pier 1** – (one test point: #188) Near the pier, wind speed would be 11 mph, meeting the pedestrian comfort criterion. No wind hazard would occur.
- **Job Corps** – (11 test points: #8, 9, 10, 11, 12, 13, 14, 15, 16, 17, 28) Wind speeds would range from 7 to 19 mph; wind speeds at six of the 11 test points (#8, 11, 13, 15, 16, 17) would meet the pedestrian comfort criterion. One wind hazard, with a duration of 15 hours per year, would occur (#12) on the east side of Avenue C.

Compared to existing conditions, with the Project, 10 percent exceeded wind speeds would be: reduced by 4 to 8 mph at the four test points (#8 – 11) at the two northernmost Job Corps buildings; increased by 4 mph at one test point (#12) at the south end of the Job Corps building, at 5th Street and Avenue C; decreased by 4 to 10 mph at the five test points (#13 - 17) at the two southernmost Job Corps buildings; and, decreased by 3 mph at the one test point (#28) at the easternmost Job Corps building. Overall, wind speeds would decrease by 3 to 10 mph at 10 of those 11 test points, and would increase by 4 mph at the one remaining test point.

The Project would eliminate nine existing wind hazards, with a total duration of 49 hours per year, and create one new hazard, with a duration of 15 hours per year, at Job Corps test points. The Project would: eliminate existing wind hazards at the four test points (#8 – 11) at the two northernmost Job Corps buildings; create a new hazard at one test point (#12) at the south end of the Job Corps building at 5th Street and Avenue C; and eliminate existing hazards at the five test points (#13 - 17) at the two southernmost Job Corps buildings. An existing wind hazard does not occur at the easternmost Job Corps building (Test Point 28), and the Proposed Project would not create a new wind hazard at this location.

PROJECT IMPACTS

Impact WS-3: The phased development of the Proposed Project could temporarily result in the creation of a Section 148 wind hazard, an increase in the number of hours that the wind hazard criterion is exceeded or an increase in the area that is subjected to wind hazards. (*Significant and Unavoidable*)

As described in Chapter II, Project Description, Section K, buildout of the proposed Development Program would be phased and would occur over 15 to 20 years. The wind testing performed for this EIR provides direct information about the wind conditions on sidewalks, streets, parks, and open spaces within and in the vicinity of the Proposed Project only in its example configuration, namely, when the Proposed Project is complete. While the wind test cannot provide numerical results about wind conditions during interim stages of development, it is reasonable to infer from the wind test results that during interim stages of development, wind hazards would occur at public locations that were not identified in the Project wind test scenario and/or previously identified wind hazards would be increased in severity or extent.

Following the completion of the first building or the first cluster of buildings of the Proposed Project in this windy site, there could be one or more wind hazards similar to those identified at the perimeter of the completed development. Those wind hazards would be temporary, but they would be likely to exist until adjacent buildings were completed and provide shelter from the unabated force of the wind from the Bay. Since the duration of the buildout is expected to be a number of years, temporary mitigation measures, such as a combination of fences, shrubs and trees, and street furniture to offer wind protection and/or to limit access to the hazard area, would be necessary to prevent exposure of pedestrians, residents or occupants to hazardous winds in pedestrian areas during that temporary interval.

Once the surrounding buildings have been completed and provide effective wind shelter, these temporary impacts would cease. However, depending upon the circumstances of the construction, these temporary impacts could continue until the Proposed Project is completed in 15 to 20 years. Because such impacts are anticipated to occur, they are considered to be potentially significant and unavoidable impacts.

Because potential wind hazards could result from a very large number of possible combinations of different possible project building designs, and permutations of project building construction sequences during the buildout of the Proposed Project, predicting the occurrence of all such hazards is not possible. Instead, the potential presence of hazards should be assumed in the immediate vicinity of new or under-construction buildings exposed to winds from the Bay.

Mitigation Measure M-WS-3: Identification of Interim Hazardous Wind Impacts

1. To identify nearby locations where potentially hazardous winds might occur as a result of the new construction during the phased buildout of the Development Program, the project sponsors shall contract with a qualified wind consultant. At least once a year, throughout construction of the Proposed Project, the wind consultant shall visit the project site, shall carefully review and consider the designs of all buildings that are approved or under construction using plans that shall be provided by the project sponsors and TIDA, shall carefully review the status of site development and building construction to date, and shall identify locations where potentially hazardous winds are likely to occur in pedestrian areas (including temporary and permanent sidewalks, streets and construction roads, and public open spaces) as a result of the new construction that would occur as part of the Proposed Project. The qualified wind consultant shall work with the project sponsors to identify structural measures and precautions to be taken to reduce exposure of persons to potentially hazardous winds in publicly accessible areas. The structural measures and precautions identified by the wind consultant could include, but not be limited to, measures such as: warning pedestrians and bicyclists of hazardous winds by placing weighted warning signs; identifying alternative pedestrian and bicycle routes that avoid areas likely to be exposed to hazardous winds; installing semi-permanent

windscreens or temporary landscaping features (such as shrubs in large planters) that provide some wind sheltering and also direct pedestrian and bicycle traffic around hazardous areas.

2. For the active construction areas, the wind consultant may identify those construction sites that would be especially exposed to strong winds and may recommend construction site safety precautions for those times when very strong winds occur on-site or when they may be expected, such as when high-wind watches or warnings are announced by the National Weather Service of the National Oceanic and Atmospheric Administration. The objective of construction site safety precautions shall be to minimize risks and prevent injuries to workers and to members of the public from stacked materials, such as shingles and sheets of plywood, that can be picked up and carried by very strong winds, as well as from temporary signage, siding or roofing, or light structures that could be detached and carried by wind. As part of construction site safety planning, the project sponsors shall require, as a condition of the contract, that contractors shall consider all such wind-related risks to the public that could result from their construction activities and shall develop a safety plan to address and control all such risks related to their work.
- 3. TIDA shall ensure, by conditions of approval for horizontal work activity, and the Planning Department shall ensure by conditions of approval for building permits and site permits, that the project sponsors and the subsequent building developer(s) cooperate to implement and maintain all structural measures and precautions identified by the wind consultant.
- 4. TIDA shall document undertaking the actions described in this mitigation measure, including copies of all reports furnished for vertical development by the Planning Department. TIDA shall maintain records that include, among others: the technical memorandum from the EIR; all written recommendations and memoranda, including any reports of wind testing results, prepared by the wind consultant(s) in the conduct of the reviews and evaluations described in this mitigation measure; and memoranda or other written proof that all constructed buildings incorporate the requisite design mitigations that were specified by the wind consultant(s).

Implementation of the precautions required by Mitigation Measure M-WS-3 would reduce the exposure of pedestrians to the effects of hazardous winds during the buildout of the Development Program. With implementation of Mitigation Measure M-WS-3, the potential impact would be reduced as much as practicable. However, because not every wind hazard may be identified by a wind consultant's review, wind hazards can still occur. It should not be expected that all of the wind hazards identified in prior wind testing would be eliminated. Therefore, these wind hazards must be considered to be potentially significant and unavoidable impacts.

Impact WS-4: Section 148 wind hazards would occur at publicly accessible locations in the Development Plan Area. These wind hazards would represent a general reduction in the number of existing wind hazards and the overall duration of the wind hazards. Changes in building design, height, location, and orientation, as well as changes in the overall configuration of the Project, could result in wind hazards that differ from those found for the representative design Project. The wind hazards could occur in different locations, could increase the number of hours that any wind hazard would occur, and/or could increase the area that would be subjected to wind hazards. (*Significant and Unavoidable with Mitigation*)

Project General Wind Conditions

Comparative wind tests show that the representative design of the Proposed Project would reduce wind speeds and the occurrence of wind hazards throughout most of the built area of the Proposed Project. The study also shows that the Proposed Project would have no adverse effect on winds in the open spaces outside of the built area.

Wind speeds would vary widely across the Development Plan Area. As should be expected, wind speeds would remain high in the shoreline parks and open spaces, which are fully exposed to the winds approaching Treasure Island over the Bay. Since the Project abuts the shoreline area, in general, wind speeds would be higher along the Project's outer edges – west, north and south – while winds generally would diminish in the interior of the developed neighborhoods of the Project. Although the wind speeds that would be exceeded 10 percent of the time would be 12 mph or more at nearly two-thirds of the 200 Project test locations, wind speeds at 74 test point locations would be at or less than the 11 mph pedestrian comfort criterion of the Planning Code.

The wind speeds that would occur 10 percent of the time within the interior of the Project would be similar to those found in some of San Francisco's windier areas, such as Mission Bay.

The strong existing winds and their accompanying higher incidence of wind hazards would still occur in the exposed shoreline parks and open spaces. Existing wind hazards would continue to occur in the new Project open spaces, including a number of locations along the Cityside Waterfront Park, Cultural Park and Waterfront Plaza. These strong winds and accompanying wind hazards in Project open spaces would not be caused by or altered by the Project, but simply reflect the overall wind environment of Treasure Island.

Project Wind Hazards

Of all 200 locations in the Development Plan Area that were tested in the wind tunnel, wind hazard conditions were found at 49 of these locations. In general, the relative incidence of wind hazards within the Project would be higher along the Project's outer edges and wind speeds and the incidence of wind hazards generally would diminish in the interior of the Project.

Examples of locations where higher wind speeds and a higher incidence of wind hazards would occur primarily because they are located at an outer edge of the developed area include:

- west: along Cityside Avenue and the north end of the Waterfront Plaza;
- north: along 10th Street;
- east: along 4th Street, Eastside Avenue and the east end of 2nd Street; and,
- south: along the west end of 1st Street.

Within the interior of the developed area of the Proposed Project, the wind hazards could be caused by local wind effects of the nearby individual high-rise towers and/or by strong incident winds that channel along street canyons, between the building masses. Examples of such locations include:

- the north end of Cityside Alley;
- along Avenue C, from 10th Street to 4th Street; and,
- along 3rd Street, between Eastside Avenue and Avenue D.

The relatively high local incidence of wind hazards that would occur within the Project's central area, generally bounded by the Cultural Park, 4th Street, Avenue D, and California Avenue, may be due to several contributing causes. First, that area is open to the predominant winds from the west, which can enter through the Waterfront and Cultural Parks. Second, the Project buildings there are generally more widely spaced, thus offering less mass to block ground-level winds. Third, this area would have several high-rise buildings, including the tallest two towers in the Proposed Project, so adverse local wind effects caused by those high-rise towers would be expected to occur.

Comparison of Project and Existing Wind Hazards

Evaluation of the Project's changes to existing wind conditions at the 23 comparable existing / Project locations shows that the Project would reduce wind speeds or the occurrence of wind hazards at all but one location, a Job Corps building on Avenue C. Based on this information and further evaluation of the basic wind data, for all of the above examples, the overall incidence and the durations of the wind hazards that would result from the Project would be similar to, or less than, those wind hazards that now occur on Treasure Island. The longer duration Project hazards, such as the approximately half-dozen hazards of 10 hours per year or more, that would occur on Avenues C and D in the central area, are representative of the wind hazards that clearly can be attributed to the Proposed Project, while the rest of the wind hazards identified for the Project may be considered to be equivalent to, or less than, the existing wind hazards on Treasure Island.

Potential to Mitigate Wind Hazards

Whatever the causes of the individual wind hazards, efforts should be made to reduce the wind hazards that would occur, or to limit the exposure to those hazards by residents and visitors, in the developed areas of the Proposed Project.

Wind hazards might be substantially reduced, but not totally eliminated, by design measures adopted during development. Most of the short-duration wind hazards that would occur in mid-block locations could be effectively eliminated by simple design measures that change the shape of the building or height of its street wall, and/or a combination of street furniture and landscaping that would protect pedestrian walkways and building entrances.

Addressing the hazards at the large intersections and in open areas within the Project interior would be much more difficult; given the open nature of these spaces, there may be no practical way to eliminate all wind hazards in these open areas without changing their basic character. However, it should be possible to substantially reduce or possibly eliminate individual wind hazards that would be caused by individual buildings.

Wind hazards that occur at the developed outer edges of the Project would also be difficult to mitigate, since the Project must have edges where the buildings adjoin open space and are exposed to the full force of the existing winds from the Bay. Considerable effort may be necessary to develop combinations of measures that would prove effective in reducing the occurrence of those particular hazards, which may prove intractable. Some may be reduced or eliminated by simple design measures that do one or more of the following: 1) introduce some topographic variation and landscaping into the adjoining, upwind open space, 2) change the shape of the building or height of its street wall, 3) add a combination of street furniture and landscaping that would protect pedestrian walkways and building entrances.

Finally, while some topographic variation and the addition of landscaping and street furniture can reduce wind speeds and eliminate wind hazards in specific locations of the open spaces, there appears to be no practical way to eliminate all wind hazards in Project open spaces without changing the basic character of these open spaces.

Mitigating Effects of Landscaping

Wind testing of the representative massing model of the Proposed Project was performed without including models for potential landscaping. Well designed and executed landscaping, including public art, fences, trellises and arbors, as well as shrubs and trees can substantially reduce wind speeds in pedestrian areas. Reductions of 1 to 3 mph in the wind speeds exceeded 10 percent of the time typically can be achieved; greater reductions in wind speeds can be achieved in certain situations. However, the choice of the materials and plantings must recognize the strong wind environment of Treasure Island and provide plants that can tolerate the high wind speeds and salt

air. Failure to select plants with the inherent structural strength to stand up to the winds will result in little or no wind protection for pedestrians.

Sequence of Development and TIDA Approvals

TIDA would consider various developments in the general sequence in which they are proposed over the 15- to 20-year construction period; some effects of this are discussed under Impact WS-4 above. Due to this sequence, the fact that TIDA would have the discretion to approve the construction of buildings that differ in design, location, and height from the representative design, and because the design differences could result in different wind effects, the number, duration and areas affected by those wind hazards may differ from the results presented here. Because such changes are likely to occur, and because they could result in an increase in wind hazard impacts, they are considered to be potentially significant and unavoidable impacts.

The two Mitigation Measures presented here can reduce the magnitude of these adverse impacts, but it cannot be assured that they would reduce the impacts to less-than-significant levels.

Implementation of Mitigation Measures M-WS-3 (which would require structural and precautionary measures such as placing warning signs around or restricting access to areas with potential wind hazards) and M-WS-4 (which would require wind impact review for buildings prior to design approval and would require that design changes be made to certain buildings on an as-needed basis) would reduce the magnitude of wind impacts.

Effects of Design Detail and Design Changes during Development Plan Buildout

Wind tests of a representative design of the Proposed Project were used to identify Project wind impacts. That testing demonstrates that the Project can be developed without unacceptable levels of wind hazards. However, it is anticipated that the designs of the individual Project buildings would change as the Development Plan is built out; those design changes would result in changes in on-site wind conditions. Ongoing review of the development process is required to assure that the general level of wind hazards present in the overall Project as it is being built continues to meet or exceed the performance of the representative model design as demonstrated in the wind tunnel. Mitigation Measure M-WS-4 describes an ongoing review and mitigation process. Qualified expert review and evaluation should be sufficient for most of this effort; wind tunnel testing shall not be required for any building unless, through the following-described process, it is determined that such testing is necessary.

Mitigation Measure M-WS-4: Ongoing Review and Mitigation of Hazardous Wind Impacts

1. Prior to schematic design approval of the building(s) on any parcel within the Project, the Planning Department shall require that a qualified wind consultant shall review and compare the exposure, massing, and orientation of the proposed building(s) on the subject parcel to

the building(s) on the same parcel in the representative massing model of the Proposed Project tested in the wind tunnel as part of this EIR and in any subsequent wind testing. The wind consultant shall identify and compare the potential impacts of the proposed building(s) relative to those described in this EIR.

The wind consultant's analysis and evaluation shall consider the proposed building(s) in the context of the "Current Project," which, at any given time during construction of the Project, shall be defined as the building masses used in the representative massing model of the Proposed Project, as described in this EIR, except as modified to replace appropriate building massing models with the corresponding as-built designs of all previously-completed structures and the then-current designs of approved but yet unbuilt structures. Finally, the proposed building(s) shall be compared to its equivalent current setting (the Current Project scenario).

- a. If the qualified wind consultant concludes that the building design(s) would not create a new wind hazard and would not contribute to a wind hazard identified by prior¹⁹ wind testing, no further review would be required.
- b. If the qualified wind consultant concludes that the building design(s) could create a new wind hazard or could contribute to a wind hazard identified by prior²⁰ wind testing, but in the consultant's professional judgment can be modified to prevent it from doing so, the consultant shall propose changes or supplements to the design of the proposed building(s) to achieve this result. The consultant may consider measures that include, but are not limited to, changes in design, building orientation, and/or the addition of street furniture, as well as consideration of the proposed landscaping.

The wind consultant shall work with the project sponsors and/or architect to identify specific feasible changes to be incorporated into the Project. To the extent the consultant's findings depend on particular building or landscaping features, the consultant shall specifically identify those essential features. The project sponsors shall incorporate those features into the building's/buildings' design and landscaping plans. If the wind consultant can then conclude that the modified building's/buildings' design and landscaping would not create a new

¹⁹ The term "prior wind testing" as used here in Mitigation Measures M-WS-3 and M-WS-4 shall include wind testing already conducted as part of the EIR together with other supplemental wind testing conducted subsequently and documented in conformance with these mitigation measures.

²⁰ The term "prior wind testing" as used here in Mitigation Measures M-WS-3 and M-WS-4 shall include wind testing already conducted as part of the EIR together with other supplemental wind testing conducted subsequently and documented in conformance with these mitigation measures.

wind hazard or contribute to a wind hazard identified in prior²¹ wind testing, no further review would be required.

Although a goal of this effort is to limit the wind effects of the building(s) to (1) cause the same or fewer number of hours of wind hazard in the immediate vicinity compared to the building(s) on that parcel as identified by prior wind testing, and (2) subject no more area to hazardous winds than was identified by prior wind testing, it should not be expected that all of the wind hazard(s) identified in prior wind testing would be eliminated by this measure.

- c. If, at this point in the analysis, the consultant concludes that the building(s) would cause a new wind hazard or increase a wind hazard identified in prior wind testing, and if the consultant concludes that the new or additional wind hazard is not likely to be eliminated by measures such as those described above, the consultant may determine that additional wind tunnel testing would be required. Wind tunnel testing would also be required if the consultant, due to complexity of the design or the building context, is unable to determine whether likely wind hazards would be greater or lesser than those identified in prior wind testing.

In the event the building's design would appear to increase the hours of wind hazard or extent of area subject to hazard winds, the wind consultant shall identify design alterations that could reduce the hours or extent of hazard. The wind consultant shall work with the developer and/or architect to identify specific alterations to be incorporated into the project. It is not expected that in all cases that the wind hazard(s) identified in this EIR would be completely eliminated. To the extent the wind consultant's findings depend on particular building design features or landscaping features in order to meet this standard, the consultant shall identify such features, and such features shall be incorporated into the design and landscaping.

2. If wind testing of an individual or group of buildings is required, the building(s) shall be wind tested in the context of a model (subject to the neighborhood group geographic extent described below) that represents the Current Project, as described in Item 1, above. Wind testing shall be performed for the building's/buildings' "Neighborhood" group, i.e. the surrounding blocks (at least three blocks wide and several blocks deep) within which the wind consultant determines wind hazards caused by or affected by the building(s) could occur. The testing shall include all the test points in the vicinity of a proposed

²¹ The term "prior wind testing" as used here in mitigation measures M-WS-3 and M-WS-4 is defined to include wind testing already conducted as part of the EIR together with all other supplemental wind testing conducted subsequently and documented in conformance with these mitigation measures.

building or group of buildings that were tested in this EIR, as well as all additional points deemed appropriate by the consultant to determine the building's/buildings' wind performance. The wind testing shall test the proposed building design in the Current Project scenario, as well as test the existing Current Project scenario, in order to clearly identify those differences that would be due to the proposed new building.

In the event that wind testing shows that the building's design would cause an increase in the hours of or extent of area subject to hazard winds in excess of that identified in prior wind testing, the wind consultant shall work with the project sponsors, architect and/or landscape architect to identify specific feasible alterations to be incorporated into the building(s). To the extent that avoiding an increase in wind hazard relies on particular building design or landscaping features, these building design or landscaping features shall be incorporated into the design by the project sponsors. The ability of the design alterations to reduce the wind hazard shall be demonstrated by wind tunnel testing of the modified design.

Although a goal of this effort should be to limit the building's/buildings' wind effect to (1) cause the same or fewer number of hours of wind hazard in the immediate vicinity compared to the building(s) on that parcel as identified by prior wind testing, and (2) subject no more area to hazardous winds than was identified by prior wind testing, it should not be expected that all of the wind hazard(s) identified in the prior wind testing or in the current wind testing under this mitigation measure would be eliminated.

- 3. TIDA shall document undertaking the actions described in this mitigation measure, including copies of all reports furnished for vertical development by the Planning Department. TIDA shall maintain records that include, among others: the technical memorandum from the EIR; all written recommendations and memoranda, including any reports of wind testing results, prepared by the wind consultant(s) in the conduct of the reviews and evaluations described in this mitigation measure; and memoranda or other written proofs that all constructed buildings incorporate the requisite design mitigations that were specified by the wind consultant(s).

It is anticipated, based on the wind testing results, that the total number and total duration of wind hazards for the whole of the Proposed Project would be equal to or less than those found in the wind tunnel testing of the representative model for this EIR. Implementation of the design changes required by Mitigation Measure M-WS-4 would likely reduce or possibly eliminate some of the identified wind hazards to pedestrians. However, because wind impacts depend in part on the design of each building and its surroundings, because design details or building forms that are permitted by the draft *Design for Development* may differ from those of the representative project, and because actual building designs and site plans have not yet been prepared, it is not possible to determine whether or not the proposed building designs or changes proposed through implementation of Mitigation Measure M-WS-4 would (i) cause the same or a smaller number of total hours of wind hazard; or (ii) subject no more area to hazardous winds than was found in the

wind testing described in this EIR. Therefore, even with the implementation of Mitigation Measure M-WS-4, the impacts from wind hazards would remain potentially significant and unavoidable.

Cumulative Impacts

Impact WS-5: The Proposed Project, when combined with other cumulative projects, could result in wind hazards that differ from those found for the representative design Project, either in the location of the hazard, in an increase in the number of hours that Section 148 wind hazards would occur, or in an increase in the area that is subjected to wind hazards. (*Significant and Unavoidable*)

The cumulative development projects that would occur nearby and could add to the effects of the Proposed Project are: 1) the proposed replacement of the on/off ramps from the Bay Bridge to the east side of Yerba Buena Island; and 2) the construction and operation of a 400-berth marina in Clipper Cove, which was considered at a project level in the *Transfer and Reuse of Naval Station Treasure Island Final Environmental Impact Report* certified in 2005²² but has not yet been approved or constructed. The marina's landside improvements would be part of the Proposed Project. The cumulative wind effects of the Proposed Project and the Marina Project, including the very small wind reductions due to the Marina Project's waterside improvements, would be almost entirely due to the Proposed Project. Because the Proposed Project's direct impact would be significant and unavoidable, as discussed in Impact WS-4, this cumulative impact would also be considered significant and unavoidable.

The overall effect of the Proposed Project would be to reduce wind speeds in those local areas immediately downwind of the developed area. Wind testing shows that existing Buildings 1, 2, and 3 currently shelter the harbor shoreline from winds from the north and northwest, but provide little sheltering for west and west-northwest winds. Although the Project would result in further reduction in wind speed in the Marina for north and northwest winds, it would not affect the dominant west and west-northwest winds. Wind speeds at the shoreline would be at 11 mph or more for 10 percent of the time; wind speeds would then increase with distance from the shoreline. Therefore, the wind speed would appear sufficient for the boats to enter, exit or maneuver in the harbor. Conversely, the presence of boats in the harbor would not materially slow wind speeds at the shoreline or within the Proposed Project.

The Bay Bridge on/off ramps project would not be affected by winds from the Proposed Project, nor would the Project winds be affected by the on/off ramps project.

²² *Transfer and Reuse of Naval Station Treasure Island Final Environmental Impact Report*, Planning Department Case No. 94.448, State Clearinghouse No. 1996092073, May 5, 2005. A copy of this document is available for public review at the San Francisco Planning Department, 1650 Mission Street, Suite 400, in Case File No. 2007.0903E.

IV. Environmental Setting and Impacts
I. Wind and Shadow

Cumulative wind effects would be highly localized and limited to a small area on the southern shore of Treasure Island, where there would be a significant and unavoidable impact; however, only the Proposed Project would make a considerable contribution to that cumulative wind effect.

J. RECREATION

This section analyzes the potential for both project-level and cumulative environmental impacts of the Proposed Project related to recreation. The Setting discussion describes the existing recreational resources in the Development Plan Area. The Impacts analysis identifies significance criteria for impacts related to recreation and discusses the changes in demand for recreational facilities that would increase the use of existing recreational facilities, require construction or expansion of recreation facilities, or physically degrade existing recreational resources. Finally, cumulative effects of the Proposed Project are discussed in a regional context. Data used in this section include information obtained from the draft *Design for Development for Treasure and Yerba Buena Islands*,¹ reports from the San Francisco Recreation and Park Department (“SFRPD”), and the Recreation and Open Space Element (Recreation Element) of the *San Francisco General Plan*.

SETTING

RECREATIONAL AND PARK RESOURCES

Regional and Citywide Resources

The SFRPD owns and maintains more than 230 parks, playgrounds, and open spaces throughout the City. In addition to City-owned facilities, San Franciscans also benefit from the Bay Area regional open space system. Within the region, the National Park Service operates the Golden Gate National Recreation Area in Marin, San Francisco, and San Mateo Counties and includes attractions such as Muir Woods National Monument, the Marin Headlands, the Presidio, Fort Point National Historic Site, Alcatraz Island, the San Francisco Maritime National Historical Park, Ocean Beach, and Fort Funston. Other Federal lands include the Point Reyes National Seashore in Marin County. State park and recreation areas that benefit San Francisco residents include attractions such as Mount Tamalpais State Park, Angel Island State Park, Eastshore State Park (a State seashore operated by the East Bay Regional Park District [“EBRPD”]), the Candlestick Point State Recreation Area, and San Bruno Mountain State Park. Other regional resources include the EBRPD-owned public open spaces in Alameda and Contra Costa Counties,² the Midpeninsula Regional Open Space District-owned public open spaces in San Mateo and Santa Clara Counties,³ and other county and city park and recreation areas throughout the larger

¹ Treasure Island Development Authority, *Design for Development for Treasure and Yerba Buena Islands*, public review draft, March 5, 2010.

² The East Bay Regional Park District is the largest regional park district in the nation and includes 65 parks and over 1,100 miles of trails on more than 98,000 acres.

³ The Midpeninsula Regional Open Space District has 26 open space preserves (24 of which are open to the public) and has permanently preserved over 57,000 acres of open space.

Bay Area. In addition, thousands of acres of watershed and agricultural lands are preserved as open spaces by water and utility districts, such as portions of the San Francisco Public Utilities Commission Peninsula watershed lands in San Mateo County and Alameda Creek watershed lands in eastern Alameda County.

In 2009, SFRPD owned and operated approximately 3,370 acres of permanently dedicated, publicly accessible recreational areas and open space.⁴ Many of the City's open space sites are under the jurisdiction of public agencies other than the SFRPD, including the Port of San Francisco ("the Port"), the San Francisco Public Utilities Commission, the San Francisco Redevelopment Agency, and the Department of Public Works. These spaces include shoreline access; reservoirs; grounds of public institutions; and streets, alleys, and undeveloped street rights-of-way. These non-SFRPD sites are often intended for public uses other than recreation, so the site's role as open space is secondary to the prime use. Their role as open space is important, as they supplement playgrounds and parks and provide visual resources.

Combined with the approximately 3,010 acres of parks and open space owned and operated by other City agencies, state agencies, and federal agencies, San Francisco residents have access to about 6,380 acres of parkland and open space, including a variety of parks, walkways, landscaped areas, recreational facilities, playing fields, and unmaintained open areas.⁵ The City also owns and operates Sharp Park in the City of Pacifica and Camp Mather in Tuolumne County near Yosemite National Park, both of which are outside of the City limits. Among the SFRPD's responsibilities are the management of 15 recreation centers; 9 swimming pools; 6 golf courses; and hundreds of tennis courts, baseball diamonds, athletic fields, and basketball courts. Most of these properties have one or more buildings and/or recreational facilities as well as paving, signage, irrigation, electrical, water, and sewer systems. The SFRPD also manages many of the City's signature facilities which attract visitors throughout the region, such as the Palace of Fine Arts, Golden Gate Park, Coit Tower, the Marina Yacht Harbor, AT&T Park (S.F. Giants ballpark), and Candlestick Park (the San Francisco 49ers football stadium).

The City's downtown area includes a variety of privately owned open spaces that are accessible to the public. Many of these open space areas were developed as a result of the 1985 *Downtown Area Plan* of the *General Plan*, while others were built prior to 1985. Currently, there are approximately 68 privately owned, publicly accessible open spaces in the city's downtown area.⁶ These spaces range from outdoor parks, plazas, urban gardens, and pedestrian walkways to

⁴ San Francisco Department of Public Health, *Healthy Development Measurement Tool*. <http://www.thehdm.org/indicators/view/8>, accessed April 6, 2010.

⁵ *Ibid.*

⁶ San Francisco Planning and Urban Research Association, *A Guide to San Francisco's Privately-Owned Public Open Spaces — Secrets of San Francisco*, November 19, 2008. http://www.spur.org/publications/library/report/secretsofsanfrancisco_010109, accessed April 6, 2010.

interior spaces such as atriums, terraces, and rooftop gardens. Among the privately owned, publicly accessible outdoor open spaces in the downtown area are the 2-acre Sydney Walton Park at Front and Jackson Streets, the 4-acre Levi's Plaza Park at Battery and Filbert Streets, and the 0.5-acre Redwood Park at Washington Street between Montgomery and Sansome Streets.

The approximately 170 acres of existing recreational facilities and open space, e.g., athletic fields, ball courts, and open spaces, on Treasure Island and Yerba Buena Island are not included in the City's system of parks and open space, as they are under Federal jurisdiction. Consequently, existing recreational facilities and open space on Treasure Island and Yerba Buena Island are not owned or operated by the SFRPD.

Nearby and Adjacent Recreational Facilities

The waters of San Francisco Bay surround the Islands. Alameda County is about 2.5 miles to the east and San Francisco is about 2 miles southwest.⁷ Thus, nearby recreational facilities such as the Embarcadero Promenade and the Ferry Building Plaza in San Francisco and Middle Harbor Shoreline Park and Berkeley Aquatic Park in the East Bay are accessible by transit and automobiles, but not by foot. Segments of the 290-mile-long San Francisco Bay Trail ("Bay Trail")⁸ in San Francisco and in the East Bay are also accessible by transit and automobiles. The nearest segment of the Bay Trail in San Francisco is located along the City's eastern shoreline from Mission Bay to the Golden Gate Bridge. This segment is continuous and consists of on-street (bike lanes and sidewalks), off-street (shared-use paved or gravel paths), and unimproved on-street portions (no bike lanes and/or sidewalks). The closest segment in the East Bay includes the off-street path at Middle Harbor Shoreline Park in Oakland, a mix of on-street and off-street bike lanes and sidewalks along 7th Street and Mandela Parkway in Oakland, and the off-street path at the Emeryville City Marina north to Aquatic Park in Berkeley and beyond.

Recreational Facilities on Treasure Island and Yerba Buena Island

Treasure Island

Treasure Island is an approximately 404-acre island in the middle of San Francisco Bay. There are approximately 90 acres of existing open space on Treasure Island, about 22 percent of its total land area. Open space and recreational facilities include water-related recreation and boating facilities, indoor and outdoor recreation facilities, and a variety of parks, multi-use paths, picnic

⁷ All distances from the Proposed Project are measured from the existing horseshoe-shaped Administration Building in the southwest corner of Treasure Island.

⁸ The San Francisco Bay Trail is a multi-purpose recreational trail that, when complete, will encircle San Francisco and San Pablo Bays with a continuous 500-mile network of bicycling and hiking trails connecting the shoreline of all nine Bay Area counties, linking 47 cities, and crossing the major bridges in the region.

areas, and open space. The Clipper Cove Marina currently accommodates about 100 slips.⁹ There are boat ramps (Piers 11 and 12) at the northeastern end of Clipper Cove on the south side of Treasure Island and a fishing pier (Pier 23) on the City side of Treasure Island. Sailboarders and other water-oriented recreationalists use the boat ramp at the north end of Treasure Island to launch water craft into the Bay. The Treasure Island Sailing Center, located near Pier 1, provides instruction and facilities for sailors of all skill levels and includes year-round racing and adaptive sailing programs for youth and adults.

On the east side of Treasure Island there is a fitness center, a gymnasium, a skating rink, a 1,000-seat theater, and a 12-lane bowling alley. The Treasure Island Homeless Development Initiative (“TIHDI”) occupies the fitness center and gymnasium. The skating rink, bowling alley, and theater were housed in a set of three adjacent buildings that are now considered to be unsafe because of hazardous conditions such as mold. In addition, none of these buildings have transformers; thus, they lack electricity and could not be reoccupied even if the buildings were safe.¹⁰ Regional-serving outdoor recreation facilities are concentrated in the interior of the island, north and east of the U.S. Department of Labor Job Corps campus. Regional recreation facilities on Treasure Island include baseball diamonds,¹¹ a pitching green, a soccer pitch¹², rugby fields,^{13,14} multi-use fields, two tennis courts, basketball courts,¹⁵ a miniature golf course, and two playgrounds.

Open spaces include four parks and picnic areas, walking and bicycling trails, and a jogging trail on the perimeter berm. The 3.7-acre Great Lawn on the western shore of Treasure Island is the location for many of the special events hosted on Treasure Island such as the two-day Treasure Island Music Festival.

Recreational facilities are also located on the Job Corps campus and include multi-use fields, one baseball diamond on the northern portion of the campus, and an indoor gymnasium. These

⁹ Environmental review of the expansion of Clipper Cove to a 400-slip marina was completed as part of the *Final Environmental Impact Report for the Transfer and Reuse of Naval Station Treasure Island* (June 2006) and is not part of the Proposed Project.

¹⁰ Treasure Island Development Authority, Treasure Island Property Inventory, October 24, 2007.

¹¹ The San Francisco Little League uses three Treasure Island baseball fields located at Avenue M and 4th Street (Teppar Field), at Avenue M and 8th (Ketcham Field), and at Avenue H and 6th (TI #3).

¹² The soccer pitch located at the southwest corner of Avenue H and 9th Street is one of 28 regional soccer fields in the City used by District 1 of the California Soccer Youth Association.

¹³ The San Francisco Gaelic Athletic Association (SFGAA) has developed approximately 13 acres of rugby fields on Treasure Island, including a home field, Páirc na nGael, located at Avenue E between 11th and 13th Streets; a practice field (Field C), at Avenue H between 11th and 13th Streets; and a youth home field, Páirc na nOg, at Avenue F and California Avenue. The SFGAA also has a clubhouse at 410 13th Street.

¹⁴ The San Francisco Golden Gate Rugby Club dedicated a new home field, Rocca Field, at Avenue H and California Avenue, and shares Field C at Avenue H between 11th and 13th Streets with the SFGAA.

¹⁵ The San Francisco Stars Netball Club home court is located between Avenue M and H and California Avenue and 3rd Street.

facilities are for the exclusive use of Job Corps students; however, the multi-use field at the southeast corner of Avenue D and 9th Street is currently used as the home field for the San Francisco Fog Rugby Football Club.

Yerba Buena Island

- Yerba Buena Island is an approximately 160-acre island in the middle of San Francisco Bay.¹⁶ There are approximately 80 acres of existing parks and open space on Yerba Buena Island, about 50 percent of the total land area. There are beach areas and picnic grounds at the foot of Clipper Cove, and an oval multi-purpose field located near the peak of Yerba Buena Island that is used by local residents. Approximately 74 acres is in open space that generally extends to the water on the steep north and west sides of Yerba Buena Island and contains both valuable habitat for native vegetation communities and degraded habitat comprised of non-native and invasive vegetation.

Existing Recreation Demand

Existing residents and workers on Treasure Island and Yerba Buena Island generate local demand for parks and open space. The existing residential population within the Project Area is about 1,820 persons. Existing employment within the Project Area is about 320 persons. As stated above, there are a total of approximately 170 acres of existing recreation areas and open space in the Development Plan Area. Therefore, based on an estimate of 170 acres, the existing ratio of residents to acres of recreation areas and open space is approximately 94 acres per 1,000 residents, which is greater than both the current Citywide ratio of about 8 acres of recreation areas and open space per 1,000 residents¹⁷ and the ratio of 10 acres per 1,000 residents suggested by the National Park and Recreation Association (“NPRA”). The existing ratio of residents and employees (i.e., daytime population) to acres of recreation areas and open space is approximately 80 acres per 1,000 residents/employees.

¹⁶ The Caltrans right-of-way for the Bay Bridge takes up about 18 acres of land area. The U.S. Coast Guard owns and operates a 48-acre facility south of the Bay Bridge. The Coast Guard Property is not included in the Project Area.

¹⁷ According to the Association of Bay Area Governments’ (“ABAG”) *Projections 2009*, the population of San Francisco as of January 1, 2010, was estimated to be about 808,700, yielding a ratio of approximately 8 acres of parks and open space per 1,000 San Francisco residents based on a total of 6,380 acres of City, State, and Federal property permanently dedicated to parks and open space.

PARK AND RECREATION NEEDS

The City has not established a Citywide target ratio of public open space to residents¹⁸ because of San Francisco's population density, small land area, and other development constraints.

However, under Policy 2.1 of the Recreation Element of the *General Plan*, the City identified the need to increase the per capita supply of public open space to a level closer to the NPRA-suggested ratio of 10 acres per 1,000 residents. As part of this effort, City residents voted in favor of the 2008 Clean and Safe Neighborhood Parks Bond, which is expected to augment the number of City parks (primarily in the eastern part of the City) and fund renovations and repairs to parks, playgrounds, and athletic fields throughout the City.¹⁹

Within San Francisco, the "neighborhood service areas" concept is used to distribute SFRPD facilities and services throughout the City's neighborhoods. The service area concept is based on the distance most users are willing to walk to reach an open space or recreation facility, and varies based on the size and type of open space and the nature of the surrounding topography. The commonly accepted distance for pedestrian access to community services or facilities is generally a 1/2 mile (a 10-minute walk) for the general population and a 1/4 mile (a 5-minute walk) for families with children.

The City's open spaces and recreational facilities are categorized as city-serving, district-serving, neighborhood-serving or sub-neighborhood serving, depending on their size and the facilities offered.²⁰ City-serving open spaces vary in size from small areas with unique features to large parks and have a service area of a 1/2-mile radius around the park. Several large park and open space areas, including Golden Gate Park, the Lake Merced Complex, Glen Canyon Park, and John McLaren Park, amount to about one-half of the total SFRPD-owned acreage. In addition, smaller areas with unique attributes, such as water features or hilltop vista points, attract residents from the entire City and function as City-serving open spaces even though they are smaller in size. Unlike neighborhood facilities, City-serving parks and open spaces provide programs, activities, or recreation opportunities that serve the City as a whole. District-serving open spaces are generally larger than 10 acres and have a service area of a 3/8-mile radius around the park, while neighborhood-serving parks are generally 1 to 10 acres and have a service area of a 1/4-mile radius around the park. Sub-neighborhood-serving open spaces, often referred to as

¹⁸ Although the National Park and Recreation Association formerly called for 10 acres of open space per 1,000 city residents, the association no longer recommends a single absolute "average" of park acreage per population, in recognition of the fact that it is more relevant that each area plan and program facilities be based upon community need. More important than total acreage is accessibility (location, walking distance) and whether the facility provides needed services to the population in question.

¹⁹ San Francisco Recreation and Park Department, *2008 Clean and Safe Neighborhood Parks Bond — Planning Report*, October 2007, pp. 11-12.

²⁰ San Francisco Planning Department, *General Plan Recreation and Open Space Element*, see Policy 2.1 and Figure 2: Public Open Space Service Areas.

mini parks, are less than an acre and are too small to accommodate athletic facilities. The service area for sub-neighborhood parks is a 1/8-mile radius around the park.

The General Plan Recreation and Open Space Element notes that “while the number of neighborhood parks and facilities is impressive, they are not well distributed throughout the City...The [unequal distribution] merits correction where neighborhoods lacking parks and recreation facilities also have relatively high needs for such facilities.” The Recreation Element defines “high need areas” as areas with high population density or high percentages of children, seniors, or low-income households relative to the City as a whole, and “deficient” areas as areas that are not served by public open space, areas with population that exceeds the capacity of the open spaces that serve them, or areas with facilities that do not correspond well to neighborhood needs.

High-need areas and deficient areas are identified in the Recreation Element based on information from the 1980 U.S. Census.²¹ The Downtown, South of Market, and Mission neighborhoods, as well as the neighborhoods along the eastern waterfront of the City, have both the highest concentration of needs, based on demographic data such as residential density, number of children, number of seniors, and average household income, and are the least-served areas of the City. However, Treasure Island and Yerba Buena Island were not considered when the Recreation Element was initially developed in 1986; therefore, the existing parks and open space on the Islands are not included in the City’s *General Plan*. The Planning Department is revising the Recreation Element and has identified Treasure Island as an opportunity area for additional regional-serving open space.²²

In 1998, the City initiated the “Great Parks for a Great City Assessment Project” to determine the condition of the park system as well as to determine future needs. In August 2004, the SFRPD published a *Recreation Assessment Report* (“*Recreation Assessment*”) that evaluated the recreation needs of San Francisco residents.²³ Nine service area maps were developed for the *Recreation Assessment* and were intended to assist SFRPD staff in assessing where services are offered, how equitable the service delivery is across the City, and how effective the service is as it applies to participating levels overlaid against the demographics of where the service is provided.

The maps define service areas by the capacity of the facility as designed and, in some cases, as actually being used, not by distance. Maps are provided for ball fields, pools, outdoor basketball

²¹ San Francisco Planning Department, *General Plan Recreation and Open Space Element*, Figure 3 through Figure 8 and Map 9.

²² San Francisco Planning Department, *Draft Recreation and Open Space Element*, May 2009, Map 2: Existing and Proposed Open Space, pp. 21-23. http://openspace.sfplanning.org/docs/Recreation_and_Open_Space_Element.pdf, accessed April 6, 2010.

²³ San Francisco Recreation and Park Department, *Recreation Assessment Report*, August 2004.

courts, multi-use/soccer fields, recreation centers and tennis courts. The existing sports fields on Treasure Island were not considered in the assessment; therefore, they were not included in the analysis. The *Recreation Assessment* concluded that, to meet standard player-to-playfield ratios, and to meet existing demand, San Francisco would need to add 35 soccer fields and 30 baseball/softball fields. Since the completion of the assessment the City has partnered with the City Fields Foundation to address the shortfall in athletic fields in the City. The *Recreation Assessment* provides suggestions and recommendations that are intended to serve as a road map for the Mayor, Board of Supervisors, Recreation and Park Commission, and key leadership staff within the SFRPD to follow to improve the delivery of recreation programs, facilities, and services.

REGULATORY FRAMEWORK

Regional

San Francisco Bay Plan

The *San Francisco Bay Plan (Bay Plan)* contains policies pertaining to the development of parks and recreational facilities in and near the Bay and public access to the Bay. The *Bay Plan* includes specific policies related to Treasure Island and Yerba Buena Island as well as general policies related to Recreation and Public Access. The Proposed Project would not include development that would be inconsistent with *Bay Plan* recreation and public access policies (see Chapter III, Plans and Policies, p. III.10).

The *Bay Plan* identifies priority use(s) for the Bay shoreline, an area defined as 100 feet inland from the mean high water line.²⁴ These priority uses are identified on the *Bay Plan Maps* and are defined as Ports, Water-related Industry, Water-oriented Recreation, Airports, or Wildlife Refuges. According to *Bay Plan Map No. 4 (Central Bay North)*, Treasure Island is not identified as a priority use area; however, the entirety of Yerba Buena Island is identified as a waterfront park, beach priority use area. The *Bay Plan Map No. 4 Policy 22* states that when Treasure Island is transferred out of Federal ownership, continuous public access to the Bay in a manner protective of sensitive wildlife should be provided, as well as parking and water access for users of non-motorized small boats, including at the north end of Treasure Island. This policy also encourages the development of a system of linked open spaces, including a large open space at the northern end of the island. In addition, *Bay Plan Map No. 4 Policy 23* encourages redevelopment of the portion of Yerba Buena Island south of the San Francisco-Oakland Bay Bridge (“Bay Bridge”) for recreational use when it is no longer owned or controlled by the U.S. Coast Guard. *Policies 24 and 25*, for the portion of Yerba Buena Island north of the Bay Bridge

²⁴ The San Francisco Bay Conservation and Development Commission (“BCDC”) is authorized to grant or deny permits for development within the priority boundary areas of the 100-foot shoreline band.

and for Clipper Cove, respectively, encourage the development of a large public open space at the center of Yerba Buena Island; a large public open space on the plateau on the eastern peninsula, adjacent to and beneath the east span of the Bay Bridge; a linked system of trails near the shoreline and at the upper elevations that connect vista points (views of the Bay Bridge, San Francisco skyline, and other important Central Bay features) and open spaces; expansion of the Clipper Cove marina and other water-oriented recreation uses; the provision of water access for small watercraft, such as kayaks, and for swimming; and preservation of beaches and eelgrass beds. The remainder of the island outside of the 100-foot-wide BCDC shoreline band may be developed for other uses consistent with the *Bay Plan Public Access* policies.

General recreation and public access policies of the *Bay Plan, Part IV, Development of the Bay and Shoreline; Findings and Policies: Recreation and Public Access*, that are relevant to the development of the Proposed Project are summarized below.

Recreation Policy IV.1 encourages the provision of diverse and accessible water-oriented recreational facilities, such as marinas, launch ramps, beaches, and fishing piers wherever possible. These facilities should be provided to meet the needs of a growing and diversifying population, and should be well distributed around the Bay and improved to accommodate a broad range of water-oriented recreational activities for people of all races, cultures, ages and income levels.

Recreation Policy IV.2 encourages preserving waterfront land for parks and beaches to meet future needs and that recreational facilities need not be built all at once. Interim use of a waterfront park priority use area prior to its development as a park should be permitted, unless the use would prevent the site from being converted to park use or would involve investment in improvements that would preclude the future use of the site as a park.

Recreation Policy IV.3 encourages the development of a variety of recreational facilities, such as waterfront parks, trails, marinas, live-aboard boats, nonmotorized small boat access, fishing piers, launching lanes, and beaches. These recreational facilities should be located, improved and managed consistent with detailed standards for the different type of recreational facilities, e.g., general recreation facilities should be as close to major population centers as is feasible and marina facilities should include viewing areas, restrooms, and non-motorized small boat launching facilities.

Recreation Policy IV.4 encourages the provision of a wide variety of recreational opportunities as a strategy for optimizing the use of the Bay for recreation. Recreational facilities within waterfront parks should include trails that can be used as components of the San Francisco Bay Trail; bus stops, kiosks and other facilities to accommodate public transit; and public launching facilities for a variety of boats and other water-oriented recreational craft, such as kayaks, canoes and sailboards. Waterfront parks should include hiking, bicycling, picnic facilities, swimming, environmental, historical and cultural education and interpretation, viewpoints, beaches, and/or fishing facilities. Recreational facilities that do not need a waterfront location, e.g., golf courses and playing fields, should generally be placed inland. Limited commercial recreation facilities, such as small restaurants, should be permitted within waterfront parks provided they are clearly incidental to the park use, are in keeping with the basic character of the park, and do not obstruct public access to and enjoyment of the Bay. In addition, historic buildings in waterfront parks should be developed

and managed for recreation uses to the maximum practicable extent consistent with the Bay Plan Map policies and other standards such as provision of public access to the exterior and the interior of the historic structure, where appropriate.

Recreation Policy IV.5 encourages the development of interpretive signs for bay resources in waterfront parks, and, where feasible and appropriate, diverse environmental education programs, facilities and community service opportunities, such as classrooms and interpretive and volunteer programs.

Recreation Policy IV.6 encourages careful design and landscape treatment for flood control projects to enhance the appearance of shoreline areas and to permit maximum public use of the shores and waters of the Bay.

Recreation Policy IV.8 encourages the comprehensive distribution of signs and other information regarding shipping lanes, ferry routes, U.S. Coast Guard rules for navigation, such as U.S. Coast Guard Rule 9, weather, tide, current and wind hazards, the location of habitat and wildlife areas that should be avoided, and safety guidelines for smaller recreational craft, via marinas, boat ramps, launch areas, personal watercraft and recreational vessel rental establishments, and other recreational watercraft use areas.

Recreation Policy IV.9 allows for the development of ferry terminals in waterfront park priority use areas and marinas and near fishing piers and launching lanes, provided the development and operations of the ferry facilities do not interfere with current or future park and recreational uses, and navigational safety can be assured. In addition, terminal configuration and operation should not disrupt continuous shoreline access and facilities provided for park and marina patrons, such as parking, should not be usurped by ferry patrons. Shared parking arrangements should be provided to minimize the amount of shoreline area needed for parking.

Public Access Policy IV.2 assures public access to the Bay via waterfront parks, beaches, marinas, and fishing piers and encourages, to the maximum extent feasible, the provision of public access to and along the waterfront through every new development in the Bay or on the shoreline, whether it be for housing, industry, port, airport, public facility, wildlife area, or other use.

Public Access Policy IV.3 encourages public access to some natural areas for study and enjoyment with the understanding that some wildlife are sensitive to human intrusion.

Public Access Policy IV.8 encourages access to and along the waterfront by walkways, trails, or other appropriate means as well as connections to the nearest public thoroughfare where convenient parking or public transportation may be available.

Public Access Policy IV.10 encourages coordination between Federal, State, regional, and local jurisdictions, special districts, and the Commission to provide appropriately sited, designed and managed public access, especially to link the entire series of shoreline parks, regional trail systems (such as the San Francisco Bay Trail) and existing public access areas to the extent feasible without additional Bay filling and without significant adverse effects on Bay natural resources. State, regional, and local agencies that approve projects should assure that provisions for public access to and along the shoreline are included as conditions of approval and that the access is consistent with the Commission's requirements and guidelines.

Local

San Francisco General Plan

The Recreation and Open Space Element of the *San Francisco General Plan* contains objectives and policies pertaining to the development of parks and recreational facilities. Although there are no objectives and policies specific to Treasure Island or Yerba Buena Island, the following general objectives and policies are relevant to the Proposed Project:

- Objective 1: Preserve large areas of open space sufficient to meet the long-range needs of the Bay region.
 - Policy 1.1: Protect the natural character of regional open spaces and place high priority on acquiring open spaces noted for unique natural qualities.
- Objective 2: Develop and maintain a diversified and balanced citywide system of high-quality open space.
 - Policy 2.13: Preserve and protect significant natural resource areas.
- Objective 3: Provide continuous public open space along the shoreline unless public access clearly conflicts with maritime uses or other uses requiring a waterfront location.
 - Policy 3.1: Assure that new development adjacent to the shoreline capitalizes on its unique waterfront location, considers shoreline land use provisions, improves visual and physical access to the water, and conforms with urban design policies.
 - Policy 3.2: Maintain and improve the quality of existing shoreline open space.
 - Policy 3.3: Create the bay and coastal trails around the perimeter of the city which links open space along the shoreline and provides for maximum waterfront access.
 - Policy 3.5: Provide new public open spaces along the shoreline.

IMPACTS

SIGNIFICANCE CRITERIA

The City and County of San Francisco has not formally adopted significance thresholds for impacts related to recreation. The Planning Department Initial Study Checklist form provides a framework of topics to be considered in evaluating potential impacts under CEQA.

Implementation of a project could have a potentially significant impact related to recreation if it were to:

- Increase the use of existing neighborhood and regional parks or other recreational facilities such that substantial physical deterioration of the facilities would occur or be accelerated;

- Include recreational facilities or require the construction or expansion of recreational facilities that might have an adverse physical effect on the environment; or
- Physically degrade existing recreational resources.

APPROACH TO ANALYSIS

For purposes of this analysis, parks are generally defined as areas of land set aside for various recreational opportunities for the public. Recreational facilities are those structures and/or improvements that are built at parks (e.g., benches, picnic tables, tennis courts, dog runs, gardens, etc.). Open space is generally defined as an undeveloped park area that may have a planted area not actively maintained by the SFRPD or other City agency and is neither an actively used park land nor a designated natural area, such as right-of-way patches or unimproved lots.²⁵ Therefore, parks and recreational facilities are typically used interchangeably, whereas open space refers to areas where the land is either being kept in its natural state or managed in order to return it to its natural state.

In determining whether a project would have a significant adverse impact on recreational facilities, this analysis considers the surrounding recreational facilities, the existing capacity of those facilities, and the expected recreational improvements that would be included as part of a project. This analysis assumes that if there are a variety of recreational facilities within the service distance of a project with sufficient capacity, there would not be a significant adverse effect on the recreational facilities. This analysis does not assume that a lack of capacity for each type of recreational activity in and of itself would be significant adverse impact. This analysis also considers the cumulative effects of a project's parks and open space improvements on the City's overall parks and open space network.

Proposed Parks and Open Space

The Proposed Project includes the construction of approximately 300 acres of new parks, recreational facilities, and open space, including approximately 216 acres²⁶ on Treasure Island and approximately 84 acres on Yerba Buena Island, as listed in Table IV.J.1.²⁷ The acreage of the Wilds, the Sports Park, and the Wetlands may vary within the ranges noted in Table IV.J.1, but together the total amount of acreage available for those uses would not exceed 94 acres. At buildout, the Development Program would include neighborhood- and region-wide serving parks

²⁵ San Francisco Recreation and Park Department, *San Francisco Park Maintenance Standards: The Manual and Evaluation Form*, May 2005, p. 17.

²⁶ This excludes the 8 acres of open space associated with the proposed school.

²⁷ A precise amount of open space cannot be calculated this early in the planning and entitlement process. The approximately 300-acre count discussed in this section is based on separate estimates of land area for each of the proposed open spaces on the Islands, some of which have a range of potential sizes, as shown in Table IV.J.1 (e.g., the Sports Park could be 25 to 40 acres).

● **Table IV.J.1: Proposed Parks and Open Space**

Parks and Open Space	Description of Use	Acres (approximate)^a
<i>Treasure Island</i>		
1. Northern Shoreline Park ^b	Passive open space; sailboat and small-craft launch sites with parking and loading areas; includes development pad for an approximately 10,000 square foot environmental education center. The Northern Shoreline Park, the Wilds (No. 2, below), and the Wetlands (No. 7, below) are contiguous and together create the Great Park.	56
2. The Wilds ^b	Habitat development with limited passive recreation	39–59 ^c
3. Sports Park	Contains up to six soccer pitches and/or rugby fields, four baseball fields, six softball fields, six volleyball courts, and eight outdoor batting cages	25–40 ^c
4. Cityside Waterfront Park	Continuous waterfront promenade; limited water access for all uses; space for temporary art installations; sculpted landform topography; seating and gathering areas	20
5. Eastern Shoreline Park and Pier 1	Multi-use active public space linked to Pier 1; landscaped areas linked to other nearby neighborhood parks; approximately 35,000 sq. ft. of community space for recreational activities and/or an interpretive center and other visitor-serving facilities	7
6. Urban Agriculture Park	Organic farm and composting facility	20
7. Wetlands ^b	Publicly accessible stormwater wetlands (paths, walkways, low fences); provides habitat	10–15 ^c
8. Eastside Commons	Linear park connecting the Island Center District and Eastside District to the Eastside Shoreline Park	3
9. Cultural Park	Plaza designed to connect the Cityside District with the Transit Hub and Clipper Cove; includes potential site for a museum or other cultural institution and the existing chapel, which would be retained	3
10. Waterfront Plaza	Promenade is the primary arrival point to Treasure Island for all travel modes; coordinated linear design with Ferry Terminal Building and Building 1 Plaza	2
11. Building 1 Plaza	Gateway plaza with three distinct levels and varied formal seating opportunities; oriented to provide City views	3
12. Clipper Cove Promenade	40-foot-wide pedestrian promenade adjacent to the Clipper Cove marina with various seating areas	4
13. Marina Plaza	Plaza located and designed to connect the Cityside and Eastside Districts with the retail core, the Ferry Terminal complex, and Clipper Cove	1.5
14. Cityside District Parks	Approximately seven neighborhood parks/plazas and playgrounds ranging from about 7,500 to 30,000 sq. ft. each in the Cityside District, some of which include community gardens	2

IV. Environmental Setting and Impacts
J. Recreation

Parks and Open Space	Description of Use	Acres (approximate) ^a
<i>Treasure Island (continued)</i>		
15. School Open Space ^d	Existing open space associated with the former elementary school that will be improved or rebuilt as part of the Proposed Project	8

Parks and Open Space	Description of Use	Acres (approximate) ^a
<i>Yerba Buena Island</i>		
16. Hilltop Park	Public open space with new trails connecting to the shore, Treasure Island, and the bicycle/pedestrian path on the east span of the Bay Bridge	6
17. Natural Areas	Areas to be managed under the Habitat Management Plan	74
18. Great Whites, Historic Gardens, Torpedo Assembly Building	Public access to the historic Nimitz House and eight other Senior Officers' Quarters (collectively, the "Great Whites"), the Torpedo Assembly Building, and improved gardens adjacent to the historic Nimitz House: the Nimitz Gardens	2.75
19. Beach Park	Protected beach location with a picnic area for use by residents and visitors	0.5
Total		<i>300 acres^{c,d}</i>

Notes:

^a Discrepancies are a result of rounding.

^b The Northern Shoreline Park, the Wilds, and the Wetlands are contiguous and together create the Great Park.

^c The size of the Wilds, the Sports Park, and the Wetlands may vary within the range of acres provided but together would not exceed the amount of acreage dedicated for those uses, a total of 94 acres.

^d The school open space is not included in the 300 acre total for parks and open space.

Source: CMG and Treasure Island Development Authority, draft *Design for Development for Treasure and Yerba Buena Islands*, March 5, 2010.

and ecological, recreational, neighborhood, and cultural areas to serve existing users and future users, including residents and visitors to the Islands. The park and open space system is intended to provide an array of recreational facilities and outdoor opportunities for all ages of residents, employees, and visitors. The approximately 300 acres of open space would include a variety of programmed and natural habitat elements, including playgrounds, open spaces, recreation areas, and shoreline trails with access improvements. This park and open space system would occupy approximately 65 percent of the Development Plan Area on Treasure Island and about 90 percent of the Development Plan Area on Yerba Buena Island. Figure IV.J.1: Proposed Open Space shows this proposed park and open space system. Table IV.J.1 lists the different elements of the park and open space program, followed by a detailed description of each of the open space areas. The numbering system in the table corresponds to the legend on Figure IV.J.1.

Two continuous north-south pedestrian-priority Mews²⁸ would be constructed in the Cityside District and would include seven neighborhood parks with features such as tot lots, raised bed gardens, and picnic tables. A continuous east-west linear park would be constructed in the Eastside District and would include features such as playgrounds, lawns, and plazas. New and/or

²⁸ The Mews are proposed as a new street typology in San Francisco called Shared Public Ways. For more information on the design of Shared Public Ways see Chapter II, Project Description, pp. II.43-II.44.

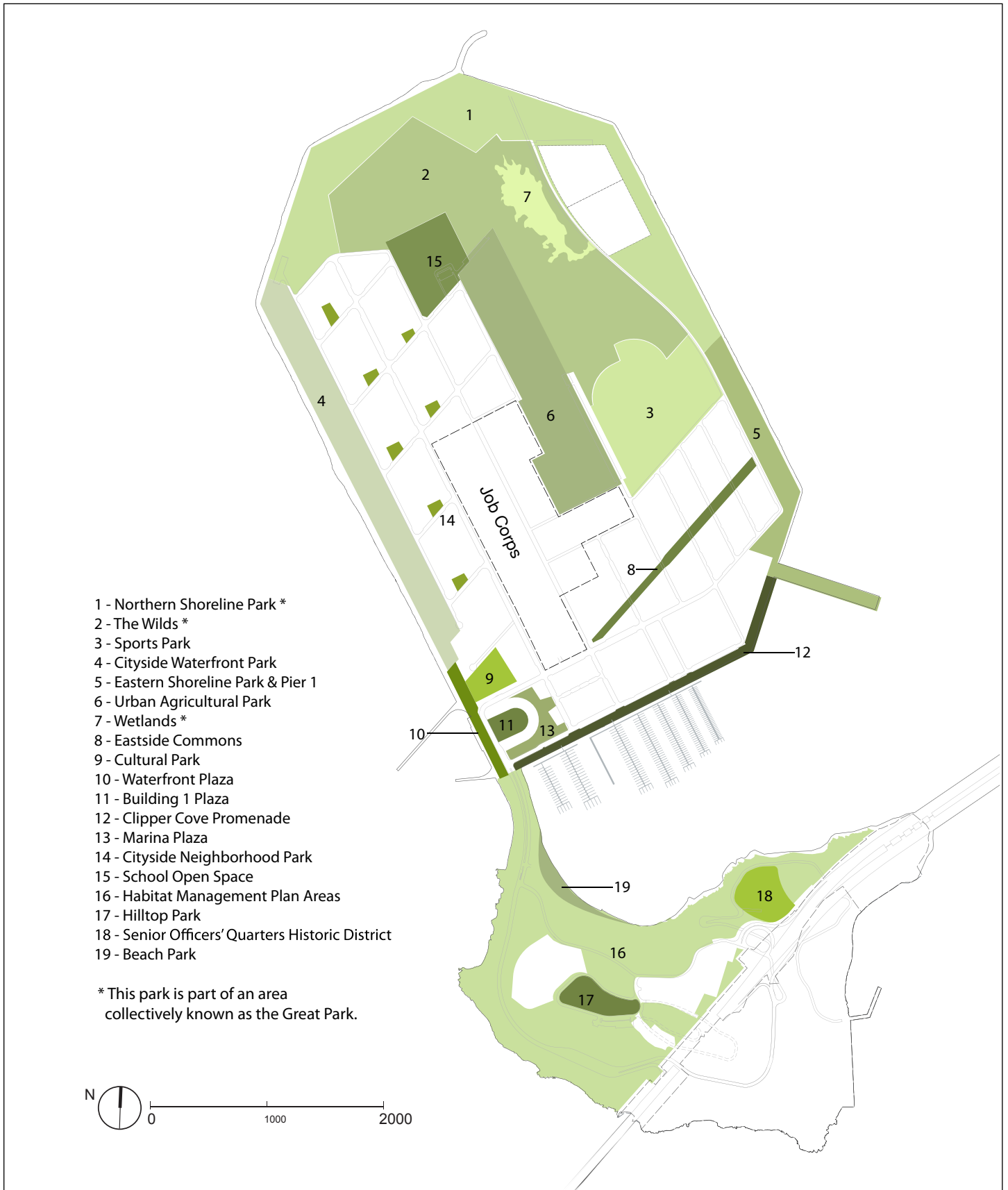

SOURCE: CMG, TICD

upgraded regional-serving facilities would include the Great Whites and Historic Gardens and the Hilltop Park on Yerba Buena Island, and the Great Park, Sports Park, and Urban Agricultural Park on Treasure Island. An approximately 3.0-mile-long multi-use path would be developed around the perimeter of Treasure Island, consisting of a 30-foot-wide, 4,522-foot-long segment within the proposed Cityside Waterfront Park and a 40-foot-wide, 2,210-foot-long segment within the Clipper Cove Promenade. This perimeter path is planned to be an extension of the San Francisco Bay Trail; however, it has not been designated as such. Pedestrian and bicycle facilities would continue on Yerba Buena Island to connect to the new pedestrian and bicycle path on the new east span of the Bay Bridge. The proposed alignment would not preclude future connections between the Yerba Buena Island pedestrian and bicycle facilities and any future pedestrian and/or bicycle path added to the west span of the Bay Bridge. The shoreline path and regional Yerba Buena Island facilities would be part of a network of bicycle and pedestrian trails connecting the various land uses that would serve as a recreational exercise system.²⁹ The recreational facilities, parks, and open space uses would be owned by the Treasure Island Development Authority (“TIDA”), and would be maintained by, or on behalf of, TIDA.

PROJECT IMPACTS

Construction Impacts

Impact RE-1: Construction of about 300 acres of parks, recreation facilities, and open space proposed by the Proposed Project would result in temporary physical effects on the environment. (*Less than Significant*)

Development of the parks and recreational facilities would require construction activities, which could vary depending on the location and type of work. Existing structures on identified park sites would require demolition, except for the existing chapel on the site of the proposed Cultural Park. The chapel would be retained in its current location. Sites would be cleared and graded, and utilities (electrical, water, sanitary sewer, and storm drainage), hardscape (e.g., concrete, asphalt, stone, walls, sport-court and play area surfacing, decking/boardwalks), and site furnishings (e.g., benches, picnic tables, drinking fountains, play equipment, fencing, artwork, lighting) would be installed. New structures (e.g., restrooms, picnic/shade shelters, kiosks, pavilions, overlooks, piers) would be

²⁹ There would be one primary bicycle route from the new east span of the Bay Bridge to Treasure Island, on Macalla Road. There would be two primary routes from Treasure Island to the new east span of the Bay Bridge. Macalla Road would be the most direct (although steeper) route to the Bay Bridge from Treasure Island. Bicyclists who opt for a longer but less steep route from Treasure Island to the Bay Bridge would use the one-way Class II bicycle lane on Treasure Island Boulevard Road and Hillcrest Road. At the intersection of Hillcrest Road and South Gate Road, bicyclists would be able to enter the Bay Bridge bicycle/pedestrian path providing access to the East Bay. If Mitigation Measure M-TR-24 (see Section IV.E, Transportation, p. IV.E.100) were to be implemented in the future, the proposed bike lane on Treasure Island Road between 1st Street and the western transit-only westbound on-ramp on Yerba Buena Island would be removed to accommodate a transit-only lane. Cyclists would continue to have Class II facilities connecting between Treasure Island and the Bay Bridge, via Macalla Road.

constructed or existing structures would be renovated. If sites are proposed to include cultural or educational institutions or other buildings, such as a museum or an environmental education center, developable pads would be constructed. Site planting would include installation of irrigation systems and would focus on re-vegetation and restoration of native plant communities, where possible. The natural open space on Yerba Buena Island would be managed under a Habitat Management Plan (“HMP”), and construction activities in these areas would generally be limited to those for revegetation, creation of trails, removal of invasive species, and other low-impact activities.

The 90 acres of existing recreational areas and open space on Treasure Island – the existing lawn area, multi-use paths, recreational fields and courts, and other open spaces – would be removed in stages as part of the development of the Development Plan Area. The 80 acres of existing parks and open space on Yerba Buena Island – the existing Historic District and Gardens, the Clipper Cove beach/picnic areas, and the open space on the north and west slopes – would be improved in place with minimal construction. At completion, there would be a net increase of 130 acres of parks and open space, including neighborhood parks and playgrounds, athletic fields, pathways, and other recreational facilities and open space. In the long term, the Proposed Project would increase the amount of publicly accessible recreational areas and open space. In the short term, existing recreational areas and open space would be removed, replaced, and/or improved, thereby temporarily decreasing the recreational areas and open space on the Islands. Although the decrease in recreational areas and open space may result in the increased use of recreational areas and open spaces at other locations on and off the Islands, this demand would not result in the physical degradation of these recreational resources, as the temporary increase in use would be dispersed among, and accommodated by, a variety of recreational areas and open spaces on the Islands, in the City, and in the Bay Area.

The existing multi-use fields, including the baseball, Gaelic football, and rugby fields, are recreational facilities that attract users from throughout the Bay Area. The baseball, Gaelic football, and rugby fields on Treasure Island, identified as home fields for several Gaelic football, rugby, and baseball organizations, would be removed as part of the Proposed Project. In the long term, the Proposed Project would increase the number of multi-use fields and hard courts in the Development Plan Area. In the short term, the phased removal of the existing rugby, Gaelic football, and baseball fields on Treasure Island would result in a reduction of recreational facilities and uses on Treasure Island. This decrease would likely result in the increased use of existing multi-use fields at other locations in the City and throughout the Bay Area. Although the removal of the Treasure Island fields would result in a temporary increase in demand for sports fields in the City and throughout the Bay Area, there are a sufficient number of fields in the Bay Area to absorb this increase. The increase in the use of City and Bay Area fields would not be expected to be intense enough, or last long enough, to have a significant effect on the playing field surfaces.

Construction of the proposed parks and recreational facilities in the Development Plan Area would be phased over a 20-year construction period; construction-related impacts in any single location would be temporary. A discussion of project-related construction impacts, which includes construction of the various park and recreation facilities, is provided in the applicable sections of this EIR: Section IV.E, Transportation; Section IV.F, Noise; Section IV.G, Air Quality; and Section IV.P, Hazards and Hazardous Materials. Since the effects related to construction of the proposed parks, recreational facilities, and open space in the Development Plan Area would be addressed as part of the analysis of construction impacts for the Proposed Project as a whole, construction of the various parks and recreational facilities would not, by itself, result in significant impacts; thus, the impact would be considered less than significant, and no mitigation is required.

Operational Impacts

Impact RE-2: The Proposed Project would result in an increase in on-site population that could result in the deterioration of existing recreational facilities. (*Less than Significant*)

Implementation of the Proposed Project would result in a residential population of about 18,640 residents and about 2,920 employees over the next 20 years (to 2030).³⁰ The increase in population and employment and its concentration in one area would result in an increased demand for and use of the City's parks, recreational facilities, and open space, as well as increased demand and use of regional, State, and Federal recreation facilities.

As part of the site preparation activities in the Development Plan Area, the existing parks and recreational facilities on Treasure Island would be removed.³¹ The majority of open space on Yerba Buena Island would be retained, and most of it is proposed to be managed as natural habitat and passive open space under the proposed HMP. The HMP has been developed to provide a management framework for the approximately 74 acres of natural areas on Yerba Buena Island; the remaining approximately 10 acres would include the historic/cultural park at the Senior Officers' Quarters, Hilltop Park, and Clipper Cove Beach Park, and would be designed to be compatible with the HMP but are not within the areas proposed for restoration and active habitat management.

The existing open space and recreational facilities in the Development Plan Area are not easily accessed from surrounding land uses because of their location in the middle of the Bay. One of the goals of the Proposed Project is to improve access from and to the Islands so that the proposed parks, open space, and recreational facilities are accessible to all City and Bay Area residents.

³⁰ See Section IV.C, Population and Housing, for assumptions about the number of new residents and employees in San Francisco that would result with the Proposed Project.

³¹ The Proposed Project does not include any changes to the existing recreational facilities on the Job Corps site and any open space related to the existing Coast Guard facility.

New Citywide and regional recreational resources are proposed, such as the 40-acre Sports Park, the approximately 100-acre Great Park, and the approximately 6-acre Hilltop Park. See Figure IV.J.1, p. IV.J.15, for the location of the different parks and open spaces. The Proposed Project also envisions the creation of a system of neighborhood parks, playgrounds, and open spaces with public plazas, courtyards, and greenways, as well as walking and biking paths.

The proposed on-site system of sub-neighborhood-, neighborhood-, City-, and region-serving parks, playground, recreational facilities, and open spaces would provide approximately 300 acres of parks and open space, which would result in a ratio of about 16 acres of parks and open space per 1,000 residents within the Development Plan Area. This ratio is double the current Citywide ratio of about 8 acres of parks and open space per 1,000 residents. As mentioned, the Proposed Project would also provide approximately 2,920 jobs, which could result in a daytime population of up to approximately 21,560 (adding the residential population of about 18,640 and assuming all residents worked on the Islands, which is unlikely). Counting the entire daytime population as a part of the population served by the parks and open space in the Development Plan Area, the parks and open space-to-population ratio would be about 14 acres per 1,000 employees and residents. In addition, the provision of soccer pitches, baseball diamonds, and other athletic fields (as part of the 25 – 40 acre Sports Park) would assist the City in meeting the existing unmet demand for 35 additional soccer fields and 30 additional baseball/softball fields identified in the *Recreation Assessment*.

Thus, given the proposed development of TIDA-owned recreational facilities and open space in the Development Plan Area and the relatively limited accessibility to City-owned and operated parks and open space, the anticipated on-site population would not increase the use of existing public facilities such that a significant adverse effect on public parks or recreational facilities would occur. Because of this, implementation of the Proposed Project would not increase the use of recreational resources such that substantial physical deterioration or degradation of existing facilities would occur, nor would it result in the need for new or expanded facilities beyond those that would be provided as part of the Proposed Project. Therefore, the impact would not be significant and no mitigation is required.

Impact RE-3: The Proposed Project may include synthetic turf fields which could have an adverse physical effect on the environment. (*Less than Significant*)

The athletic fields planned as part of the approximately 25 – 40 acre Sports Park, north and east of the existing 37-acre Job Corps campus, may be designed and constructed as synthetic turf fields. Synthetic turf fields have become popular because they provide a consistent year-round, all-weather playing surface built to withstand extended use without downtime during periods of poor weather. In addition, synthetic turf fields do not require mowing, watering, fertilizing,

seeding, aerating, pesticides, or expensive maintenance equipment. In California, used tires are the primary source for synthetic turf materials.³²

Synthetic turf fields are installed as a layered system with a drainage layer, a backing system, and “grass blades” that are infilled to resemble natural turf. Currently, synthetic grass blades are manufactured using nylon, polypropylene, or polyethylene, and are connected to a backing material. The base material, also called infill, consists of one or more granular materials that are worked in between the fibers during the installation process. This base material provides the playing field with the necessary stability, uniformity, and resiliency. Commonly used base materials are flexible plastic pellets, sand, rubber-coated sand, and granulated rubber crumb (usually from recycled tires). In San Francisco, the installation of synthetic turf fields follows City criteria which recommend the use of rubber crumb as infill.

Recycled tire material is used in many building applications, including as a component for indoor auditoriums and playground and track installations. Rubber crumb is produced by grinding used tires.³³ Steel and fiber tire components are removed during the process, and the rubber pellets are sorted by size. Pellet sizes ranging from about 1/16 to 1/4 inch in diameter are used as the infill for synthetic turf fields. Crumb rubber is typically applied at a rate of 2 to 3 pounds per square foot of field surface. Other recreation-related uses for recycled tires include ground cover (chips) under playground equipment, landscaping mulch (chips), and running track material (granular or molded). Other commercial applications for recycled tires include road construction, sidewalks, and automobile parts.

Tire rubber is a complex material that contains many naturally occurring and man-made chemicals. Crumb rubber from tires inherently contains many potentially harmful constituents that are released when the tires are worn by everyday driving. Some of these constituents remain after the tire is no longer usable and can be present when they are processed for recycling and re-used in products. Arsenic, cadmium, chromium, zinc, and iron are often found in varying quantities in used tires; however, advances in the recycling process have led to the removal of heavy metals from the recycled product, i.e. rubber crumb. Rubber crumb has also been shown to release volatile and semi-volatile organic compounds. The public has raised concerns regarding potential human health and environmental risks associated with the presence of and potential exposure to rubber crumb constituents in athletic fields, especially with regard to children’s exposure. As described in Section IV.G, Air Quality, pp. IV.G.2-IV.G.10, health effects, including increased cancer risk, are associated with long-term exposure to certain criteria

³² The California Tire Recycling Act (Public Resources Code 42870 *et seq.*) requires the California Integrated Waste Management Board to develop new markets for recycled tires.

³³ Tires are a mixture of vulcanized or cross-linked polymers, carbon black, dispersing oil, sulfur, synthetic fibers, pigments, processing chemicals, and steel or fiberglass. Tire manufacturers use a variety of formulation recipes.

pollutants and toxic air contaminants, while short-term exposure can cause or aggravate chronic respiratory disease such as asthma, bronchitis, and emphysema. Persons engaged in exercise, including users of recreational facilities, have increased sensitivity to poor air quality. Children are generally considered to be more sensitive than the general public. These populations would therefore be considered sensitive receptors. Sensitive receptors in or adjacent to the Development Plan Area include the existing population at the Job Corps site, students at nearby educational institutions, and athletes who use the recreation fields, especially youth.

In response to public health concerns, numerous government- and industry-sponsored studies have been undertaken. These studies have addressed issues such as the ingestion of rubber crumb; dermal absorption of rubber crumb; inhalation of polycyclic aromatic hydrocarbons (“PAHs”),³⁴ volatile organic compounds (“VOCs”), and particulate matter (“PM”); water quality contaminants from field stormwater runoff/leachate; and turf burns resulting in methicillin-resistant *staphylococcus aureus* (“MRSA”) infections. In 2008, Governor Arnold Schwarzenegger signed Senate Bill 1277, which required the California Integrated Waste Management Board, in concert with the Office of Environmental Health Hazard Assessment and the California Department of Public Health, to finalize a study comparing the effects of synthetic turf and natural turf on the environment by September 2010.

In January 2007, prior to the passage of the SB 1277, the Office of Environmental Health Hazard Assessment published *Evaluation of Health Effects of Recycled Waste Tires in Playground and Track Products* (“2007 Recycled Tires Report”). In February 2008, the San Francisco Department of Public Health (“SFDPH”) reviewed published documents relevant to assessing the potential for health risk associated with artificial turf.³⁵ The *2007 Recycled Tires Report* was among the documents reviewed. The SFDPH concluded that there was no bias found in the methodology, findings, or conclusions of this report. The SFDPH agreed with the conclusion that health risks associated with rubberized play surfaces are likely to be minimal and recommended the *2007 Recycled Tires Report* as a primary basis for decision-making.³⁶ Thus, current research indicates that the use of rubber crumb as a base material in the design of synthetic turf fields is not likely to pose an increased health and environmental risk via acute contact such as ingestion and dermal absorption. Neither a literature review nor any experimental analysis of inhalation routes for PAHs, VOCs, or PM was part of the scope of the *2007 Recycled Tires Report*. The SFDPH memorandum indicated, however, that air quality monitoring should be conducted on and

³⁴ PAHs are a group of chemicals that are formed during the incomplete burning of coal, oil, gas, wood, garbage, or other organic substances, such as tobacco and charbroiled meat. Human exposure to PAHs is typically to a mixture of PAH chemicals, not to individual PAH chemicals.

³⁵ City and County of San Francisco Department of Public Health, Memorandum re: Artificial Turf Fields, from June M. Weintraub and Richard Lee to Dawn Kamalanathan, Planning Director, Recreation and Park Department, February 6, 2008.

³⁶ *Ibid.*

around synthetic turf fields to better assess potential health risks associated with exposure to airborne PAHs, VOCs, and PM.

In July 2009 the Office of Environmental Health Hazard Assessment published a report on synthetic turf as a risk factor for MRSA and the air quality effects of synthetic turf fields.³⁷ The *OEHHA 2009 Report* was based on a review of existing literature and limited experimental analysis. The *OEHHA 2009 Report* did not find conclusive evidence regarding a higher incidence of turf burns on synthetic fields as opposed to natural turf fields but did identify athletes as an at-risk group for MRSA due in part to the frequent physical contact that occurs during play, as well as the propensity of athletes to have skin cuts and abrasions. In general, the major mode of bacterial infection results from player-to-player contact rather than player contact with a contaminated playing surface; however, MRSA bacteria can survive on and be transferred by inanimate objects in the environment, i.e., towels, garments, athletic equipment, and polyethylene (a plastic used in synthetic turf fibers). Public health officials believe that athletes can be protected from most bacterial infections, including MRSA, by practicing good hygiene (e.g., keeping hands clean by washing with soap and water; covering open skin area such as abrasions or cuts with a clean dry bandage; avoiding sharing personal items such as towels or razors; using a barrier between skin and shared equipment such as a towel; and wiping surfaces of equipment before and after use).

The *OEHHA 2009 Report* also concluded that existing outdoor and indoor synthetic turf fields do not generate adverse health risks for persons using the facilities due to inhalation of PAHs, VOCs, and PM from rubber crumb.^{38,39} The report also showed that, even when using the most conservative scenario (a complete data set for indoor stadiums⁴⁰), a model developed by the Office of Environmental Health Hazard Assessment to estimate the risk from inhalation showed only a minimal risk, with the caveat that “using indoor data to calculate health risks from outdoor play overestimates the outdoor risks.”⁴¹ Thus, much like the SFDPH, the *OEHHA 2009 Report*

³⁷ California Environmental Protection Agency, Office of Environmental Health Hazard Assessment, *Chemicals and particulates in the air above the new generation of artificial turf playing fields, and artificial turf as a risk factor for infection by methicillin-resistant Staphylococcus aureus (MRSA) Literature review and data gap identification*, July 2009 (hereafter “*OEHHA 2009 Report*”).

³⁸ *OEHHA 2009 Report*, p. 5.

³⁹ The *OEHHA 2009 Report* review indicated that two outdoor artificial turf fields were evaluated in the May 2009 New York State Department of Environmental Conservation and Department of Health study, and that the same two fields were studied in the 2009 TRC study, prepared for New York City Department of Health and Mental Hygiene, and that testing additional outdoor fields for the release of chemicals and particulate matter is warranted.

⁴⁰ The Dye (indoor artificial turf field) study measured VOCs, PAHs in the gas phase and associated with PM₁₀, phthalates in the gas phase, and PM_{2.5} and PM₁₀ over three fields with two containing rubber infill and the third being underlain with a thermoplastic elastomer. Thirty-eight PAHs were assayed with three PAHs occurring at the highest concentrations over both fields: naphthalene, 2-methylnaphthalene, acenaphthylene.

⁴¹ *OEHHA 2009 Report*, p. 5.

concluded that more air quality monitoring on and around synthetic turf fields should be conducted to further assess the potential health and environmental risks. The report also indicated that a more rigorous methodology and data collection system should be employed, which would include measurements from both above the fields and in the vicinity of the fields, with details regarding climactic conditions as well as rates of field use and field age and their effect on particulate release, among other data.

In November 2009, the U.S. Environmental Protection Agency (“U.S. EPA”) conducted a limited scoping study to evaluate a protocol and methodology for generating consistently collected U.S. environmental data for select tire crumb constituents.⁴² This U.S. EPA scoping report, along with results from other studies conducted by federal, state, and local organizations, such as the Consumer Product Safety Commission; the Agency for Toxic Substances and Disease Registry; the States of New Jersey, Connecticut, California, and New York; and New York City, are intended to inform the U.S. EPA’s decision-making process as to the next steps needed to comprehensively address questions from the public regarding the health and environmental risks of rubber crumb infill in athletic fields and playgrounds.

The SFRPD has collaborated with the San Francisco Department of the Environment and the City Fields Foundation to develop standards for synthetic turf purchases for SFRPD athletic fields being renovated with synthetic turf.⁴³ These efforts are part of the general purchasing requirements previously established by the Board of Supervisors as part of the larger Citywide effort to meet the 75 percent landfill diversion goal by 2010 and the zero waste goal for 2020.⁴⁴ The Citywide goals were set by Resolution 679-02 (adopted September 30, 2002). Similar goals were set for each City department under Resolution 530-04 (adopted August 17, 2004).⁴⁵

The synthetic turf standards fall into three general categories: end-of-life recycling plans, post-consumer recycled content; and heavy metal (primarily lead, chromium, and zinc) and material content.⁴⁶ San Francisco is the first known municipality in the nation to require end-of-life

⁴² U.S. EPA, *A Scoping-Level Field Monitoring Study of Synthetic Turf Fields and Playgrounds*, EPA/600/R-09/135, November 2009.

⁴³ City and County of San Francisco Recreation and Park Department, Memorandum from Dan Mauer, Capital Division, to Recreation and Park Commission re: Synthetic Turf Standards – Information Only, July 8, 2009.

⁴⁴ Purchasing requirements codified throughout the Environment Code include specifications for the purchase of paper products; numerous office, construction, park, and recreational products; and batteries.

⁴⁵ Purchasing standards are defined in part by Chapter 2: Environmentally Preferable Purchasing Ordinance of the Environment Code (adopted September 20, 2005), the Extended Producer Responsibility Resolution (adopted February 14, 2006), and Chapter 6.4 of the Administrative Code (adopted March 13, 2007) which requires recycled content materials to be used in public projects to the maximum extent feasible.

⁴⁶ These purchasing standards are in effect for the Kimbell Playground athletic field renovation in the Fillmore District of San Francisco.

recyclability as well as recycled content in synthetic turf purchases. Prospective vendors would be required to provide information showing how the standards would be met. The San Francisco Department of the Environment supports use of styrene butadiene rubber (“SBR”) in local synthetic turf fields because it has a high amount of recycled content, implementing the post-consumer recycled content standard. In general, lead and chromium are the primary heavy metal concerns; however, with the support for use of SBR rubber crumb infill, zinc content is also of concern. Zinc is found in the SBR infill and, while not a major human health hazard, it can be an aquatic toxicity hazard if tires or tire constituents sit in water for a long time or if the field drains improperly, creating standing water. In 2008, the City’s Synthetic Playfields Task Force reviewed the existing scientific literature and evaluated the potential for aquatic toxicity that may result from use of SBR rubber crumb in the installation of synthetic turf fields.⁴⁷ The task force determined that there is no imminent risk of aquatic toxicity but, as a precautionary measure, the San Francisco Public Utilities Commission staff was tasked with testing runoff levels at representative fields.⁴⁸ Testing the leachate from these fields is ongoing and results have not been published.

The Office of Environmental Hazard Health Assessment is currently performing a study to fill the data gaps identified in the *OEHHA 2009 Report*. This office has proposed a methodology, based on its review of existing studies, that would include air sampling in the vicinity of and above the new generation of artificial turf fields in outdoor settings; collection of climatic conditions to assess the effect of temperature on the infill materials; measuring concentrations of potentially hazardous chemicals and particulates; surveying of coaches to determine how much time athletes spend on these fields; rates of skin abrasion on artificial and natural turf; and bacterial analysis of soil and grass from natural turf among other things. Using these new data, California EPA staff will determine whether the new generation of artificial turf playing fields releases chemicals or particulates into the air that pose an inhalation risk to persons using the fields. OEHHA will also determine whether artificial turf fields increase the risk of infection by dangerous bacteria such as MRSA.⁴⁹

Commercial improvements to rubber crumb infill and/or other alternate infill materials⁵⁰ for synthetic turf fields are expected to occur as government- and industry-sponsored studies are

⁴⁷ The task force is made up of City residents, park advocates, and City staff from Department of Public Health, Department of the Environment, San Francisco Public Utilities Commission as well as technical experts from the University of California, San Francisco, and the Office of Environmental Health Hazard Assessment.

⁴⁸ San Francisco Recreation and Park Department, e-mail communication with Dan Mauer of the Capital Improvements Division, January 21, 2010.

⁴⁹ *OEHHA 2009 Report*, p. 19.

⁵⁰ Existing alternate infill materials such as ethylene propylene diene Monomer [M-class] rubber or thermoplastic elastomer granules have different properties than the rubber crumb derived from SBR, i.e. better flame resistance and end-of-life recyclability, less ecotoxicity.

completed over the Proposed Project's 20-year development period. Improvements to the design and installation of synthetic turf fields are also expected to occur over the 20-year development period. The project sponsors would adhere to the City's purchasing criteria for the materials needed to install synthetic turf fields and playgrounds, likely resulting in the use of materials that minimize the potential for adverse public health risks. The site selection process would also likely minimize potential risks associated with leaching to the ground water. City-approved materials and advanced design/installation techniques would be expected to be used for athletic field and playground installations throughout all phases of development. Based on the state of current research, the development of synthetic turf fields that use rubber crumb as infill material would be considered to have a less-than-significant impact on the environment, and mitigation is not required.

In light of public health concerns, the project sponsors would be encouraged to work with the SFRPD to ensure that development of artificial turf fields and other recreational facilities adhere to the latest criteria for design and development (see Improvement Measure I-RE-3a, below). The project sponsors are also encouraged to work with the SFDPH to develop an education and signage program that highlights proper hygiene practices for before and after field use as well as proper wound care for turf burns (see Improvement Measure I-RE-3b). As a final improvement measure, the project sponsors are encouraged to work with the SFDPH to develop an air quality monitoring program that would use the most rigorous methodology (i.e., from the California Office of Environmental Health Hazard Assessment or from the U.S. EPA) to better assess the potential air quality impacts of the newest generation of synthetic turf fields (see Improvement Measure I-RE-3c).

Improvement Measures

The following improvement measures are recommended to address the less-than-significant impacts related to use of rubber crumb from recycled tires in park and recreation facilities and to address public health concerns.

Improvement Measure I-RE-3a

- Where artificial turf is proposed, the project sponsors are encouraged to work with the City Fields Foundation and City Recreation and Park Department staff to design and build artificial turf fields using the latest SFRPD criteria at the time of implementation, including the City's purchasing criteria.

Improvement Measure I-RE-3b

The project sponsors are encouraged to work with the City Fields Foundation and Department of Public Health staff to develop signage that educates athletes and their families about the importance of washing hands before and after use of synthetic turf fields and the importance of proper wound care for turf-related injuries.

Improvement Measure I-RE-3c

The project sponsors are encouraged to work with the City Fields Foundation and Department of Public Health staff to develop an air quality monitoring program for the proposed synthetic turf fields that would follow a methodology developed by the Office of Environmental Health Hazard Assessment or the U.S. EPA. The methodology would include, but is not limited to, capturing air quality samples at an outdoor field and upwind of the field; identifying the heights above the field where samples are captured; and recording weather data such as ambient and field temperatures, wind speed/direction, and humidity.⁵¹

CUMULATIVE IMPACTS

Impact RE-4: Construction of the Proposed Project would not significantly contribute to cumulative impacts on the recreational use of existing parks, recreation facilities, and open space. (*Less than Significant*)

The Proposed Project's potential contribution to cumulative recreation impacts is evaluated in the context of existing, proposed, and reasonably foreseeable future development expected in the City. Development projections estimate an increase in 68,320 households, 124,800 persons, and 179,370 jobs from 2010 to 2030.⁵² Buildout of the Development Plan Area is estimated to increase the City's population by about 18,640 persons by 2030. At full buildout, the Proposed Project would provide approximately 300 acres of parks, recreational facilities, and open space to accommodate increased demand resulting from the new residents, and to serve existing City and Bay Area residents by providing improved access to the Islands by transit and by ferry. In addition, park and open space acreage in the Downtown, and South of Market areas, and along the northeastern and eastern waterfronts is proposed to be augmented as development projects such as Mission Bay, the proposed Transbay Redevelopment Plan, the Eastern Neighborhoods Community Plan, and the proposed Candlestick Park-Hunters Point project move toward completion. These projects will also result in an increase in the City's population and employment, which has been accounted for in ABAG's *Projections 2009*. Anticipated growth in the Citywide network of parks and open space will also occur as a result of the passage of the 2008 Clean and Safe Neighborhood Parks Bond,⁵³ which focuses on the development of new parks in the eastern portions of the City. In addition to this general obligation bond, the 2010–2019 Capital Plan proposes another \$175 million for the SFRPD over the second half of the Capital Plan planning period (2014–2019). These funds are expected to come from a \$25 million

⁵¹ The U.S. EPA's November 2009 *Field Monitoring Study*, pp. 13 and 18, includes a review of the methods used for air quality monitoring.

⁵² ABAG *Projections 2009*, p. 92.

⁵³ San Francisco Recreation and Park Department, *2008 Clean and Safe Neighborhood Parks Bond — Planning Report*, October 2007, pp. 11-12.

revenue bond and a \$150 million general obligation bond scheduled for 2013.⁵⁴ The provision of parks and open space acreage as a result of the implementation of reasonably foreseeable future projects including the Proposed Project would continue the City's efforts to improve the delivery of recreation programs, facilities, and services to a growing population. Therefore, the Proposed Project would not contribute to any cumulative adverse impacts on recreation, and no mitigation is required.

⁵⁴ City and County of San Francisco, *2010–2019 Capital Plan*, April 2009, p. 119.

K. UTILITIES AND SERVICE SYSTEMS

This section evaluates the Proposed Project's effects on utilities and service systems, which include wastewater collection and treatment, wastewater recycling and reuse, stormwater collection and treatment, water supply (for potable and fire-fighting water), solid waste disposal, electricity and gas infrastructure, and telecommunications. This section identifies both Project-level and cumulative environmental impacts, as well as feasible mitigation measures. Impacts related to electricity and natural gas demand are discussed in Section IV.Q, Mineral and Energy Resources.

K.1 WASTEWATER COLLECTION AND TREATMENT

SETTING

Existing Wastewater Collection System

The San Francisco Public Utilities Commission ("SFPUC") maintains and operates the existing Navy-owned wastewater collection and treatment system on Treasure Island and Yerba Buena Island. Unlike most of San Francisco, Treasure Island has separate wastewater and stormwater collection systems. Stormwater collection and treatment is discussed in Section K.3, below.

The existing wastewater collection system consists of 4- to 12-inch-diameter gravity sewer pipes, approximately 27 sewage pump/lift stations,¹ and force mains ranging from 6 to 16 inches in diameter. Pipes are made of polyvinyl chloride ("PVC"), asbestos cement, cast iron, steel, and vitrified clay. The pump/lift stations are a mix of dry-well and wet-well systems.

Treasure Island has 11 main drainage areas. In general, each has a combination lift and pump station. The lift station pushes flow up to a pump station. The pump stations feed the main trunk line that carries sewage to the wastewater treatment plant in the northeast corner of Treasure Island. The main trunk line begins at the southwest corner of Treasure Island, follows California Avenue to the east, and then goes along Avenue M to the north to connect to the treatment plant.

On Yerba Buena Island, there are two wastewater collection systems. The eastern side of the island, including the Coast Guard Station and Sector Facility, has a gravity sewer system that drains to a pump station under the Bay Bridge at the eastern tip of Yerba Buena Island. The pump station sends the flow through a 6-inch-diameter, submarine force main to the southern shore of Treasure Island. The western side of Yerba Buena Island has a gravity sewer system that flows to, and across, the causeway. It connects to the Treasure Island sewer system near the road's entrance to Treasure Island.

¹ Lift stations lift the wastewater up to a level where it can flow by gravity. Pump stations put the wastewater in the pipes under pressure; such pipes are called force mains.

Existing Wastewater Treatment

The existing Treasure Island Wastewater Treatment Plant, at the northeast corner of Treasure Island, serves both Treasure Island and Yerba Buena Island. Primary treatment facilities were built in 1961. Primary (physical) treatment typically consists of several steps to remove solid material from the wastewater flows. A common first step is to remove large objects and debris, such as rags, paper, and plastics, with bar screens. Another frequently used step is to remove grit (sand and other inorganic particles). A key step is primary clarification, in which solids are settled out and floating matter is skimmed off.

Secondary treatment facilities were added at Treasure Island in 1969. During secondary (biological) treatment, microorganisms metabolize biological matter. Following secondary treatment, the flow is chlorinated to kill pathogens, then dechlorinated.² After dechlorination, the effluent is discharged to the Bay via an outfall. The plant was upgraded in 1989 to expand

- treatment capacity to 2.0 million gallons per day (“mgd”).

The solids resulting from primary and secondary treatment are processed by anaerobic³ digestion, in which microorganisms break down organic matter. The resulting solids are dewatered by centrifuge⁴ and then trucked to the land application site in Solano County used by the City and County of San Francisco to dispose of much of its wastewater treatment solids.

- By about May 2011, the SFPUC plans to replace the anaerobic digestion process for solids with a stabilization process using lime (i.e., calcium carbonate).⁵ The lime will be added as a slurry (i.e., lime and water mixture). Typically, lime is added to untreated biosolids to raise the pH to 12 or higher, with the dosage dependent on type and concentration. The lime stops or reduces the microbial reactions that can lead to odor production. Lime can also inactivate pathogens, and may be less expensive than traditional anaerobic digestion. The lime slurry will discharge into and out of a double-walled, high-density, polyethylene, chemical tank with a capacity of approximately 5,000 gallons. Transport off site would be by truck, similar to existing solids transport off the Islands.

The quality and quantity of discharged effluent from the treatment plant is governed by a National Pollutant Discharge Elimination System (“NPDES”) permit, as described in

-
- ² Sodium hypochlorite and sodium bisulfite are used for disinfection. In fiscal year 2009-2010, the total annual usage was 21,000 dry pounds of sodium hypochlorite and 50,000 dry pounds of sodium bisulfite.
 - ³ “Anaerobic” digestion takes place in the absence of oxygen.
 - ⁴ Polymer is used in the dewatering process. In fiscal year 2006-2007, the total annual usage was 150 dry pounds.
 - ⁵ Email between Michael Marten, SFPUC, and Michael Tymoff, Mayor’s Office of Economic and Workforce Development, forwarded to Turnstone Consulting on November 30, 2010.

Section IV.O, Hydrology and Water Quality, p. IV.O.9. The regulatory agency, the San Francisco Bay Regional Water Quality Control Board (“RWQCB”), issued the NPDES permit to the Navy.⁶ The discharge limits in the current permit are described in Section IV.O, pp. IV.O.9-IV.O.11, and in Table IV.O.2 on p.IV.O.10.

Regulatory Framework

Federal and State laws and local policies govern water quality protection, as explained in Section IV.O, Hydrology and Water Quality, “Regulatory Framework,” p. IV.O.11. Water quality requirements determine the type of wastewater collection and treatment facilities needed to manage pollution. Highlights of the applicable requirements are summarized below.

⁶ The RWQCB renewed the Navy’s permit in January 2010. See Final Order R2-2010-0001, http://www.waterboards.ca.gov/rwqcb2/board_decisions/adopted_orders/2010/R2-2010-0001.pdf, accessed April 13, 2010.

Federal

The federal Clean Water Act amendments of 1972 prohibit the discharge of pollutants to navigable waters of the United States from a point source, unless the discharger has an NPDES permit. The U.S. Environmental Protection Agency (“EPA”) has delegated certain authority to the State of California.

State

The Porter-Cologne Water Quality Control Act authorizes the State Water Resources Control Board (“SWRCB”), which, in turn, delegated certain authority to the several Regional Water Quality Control Boards (“Regional Boards”) to issue and enforce NPDES permits. In addition, the SWRCB develops water quality standards and performs other functions to protect California’s waters. The Regional Boards carry out the SWRCB regulations and standards, and the Regional Boards issue and enforce permits.

The RWQCB has authority to issue and enforce the NPDES permit related to discharge of wastewater effluent from Treasure Island/Yerba Buena Island. The RWQCB also implements the Water Quality Control Plan for the San Francisco Bay Basin (“Basin Plan”), as described on pp. IV.O.14 – IV.O.15.

The SWRCB has a Sanitary Sewer Overflow Reduction Program. “A sanitary sewer overflow (“SSO”) is any overflow, spill, release, discharge or diversion of untreated or partially treated wastewater from a sanitary sewer system.”⁷ Untreated overflows frequently contain high levels of suspended solids, pathogenic organisms, nutrients, toxic chemicals, oil, grease, and other pollutants. The SWRCB adopted Water Quality Order No. 2006-0003 (“Sanitary Sewer Order”), which requires public agencies that own or operate sanitary sewer systems to develop and implement sewer system management plans to reduce SSOs. In addition, they must report all SSOs to the SWRCB’s online SSO database.

Local

San Francisco Public Utilities Commission Water Pollution Prevention Program

As discussed further in Section IV.O, Hydrology and Water Quality, “Regulatory Framework,” the City has a Water Pollution Prevention Program (“Program”) to avoid and minimize pollutants entering the City’s sewer system and storm drains, thereby reducing pollutant loading to San Francisco Bay and the Pacific Ocean.⁸ The Program includes education components for

⁷ SWRCB web site, http://www.waterboards.ca.gov/water_issues/programs/sso/index.shtml, accessed April 13, 2010.

⁸ SFPUC, “Water Pollution Prevention” web page, http://www.sfwater.org/msc_main.cfm/MC_ID/14/MS_C_ID/118, accessed on June 12, 2010.

businesses, residents, and city employees. The Program also includes several initiatives that are meant to reduce water pollution, including initiatives meant to reduce toxic chemicals used for landscaping, reduce dental mercury, reduce fats/oils/greases, minimize construction-related water pollution, minimize stormwater pollution, minimize pet waste-related water pollution, properly dispose of medications, and support green design and operation measures for businesses and households. Articles 4, 4.1, and 4.2 of the San Francisco Public Works Code contain many components of the Program.⁹

One component focuses on industrial wastewater. Industrial customers must pre-treat their wastewater effluent prior to discharge into the City's sewer system in order to reduce the pollutant demands placed upon the City's system, and to remove toxic or other types of pollutants that may not be captured by the City's wastewater treatment plants or that would interfere with the City's treatment processes.¹⁰ The City has also been working for many years to reduce fats, oil, and grease in the wastewater stream from commercial and residential kitchens, especially from restaurants.¹¹ These materials clog pipes and treatment processes. The City has recently proposed a new fats, oil, and grease ordinance, which would strengthen Article 4.1.¹² Another component of the Program is the Stormwater Management Program, which is discussed further in Section IV.O, Hydrology and Water Quality, "Regulatory Framework."¹³

San Francisco General Plan

The Environmental Protection Element and Community Facilities Element of the *San Francisco General Plan* contain the following policies relating to wastewater facilities:

Environmental Protection Element

Objective 3: Maintain and improve the quality of the Bay, ocean and shoreline areas.

Policy 3.1: Cooperate with and otherwise support regulatory programs of existing regional, State, and Federal agencies dealing with the Bay, Ocean, and Shorelines.

Policy 3.3: Implement plans to improve sewage treatment and halt pollution of the Bay and Ocean.

⁹ Relevant portions of the Public Works Code are available through the table of contents page, <http://library.municode.com/HTML/14142/book.html>, accessed June 12, 2010.

¹⁰ Article 4.1 of the SF Public Works Code governs industrial dischargers. See <http://library.municode.com/HTML/14142/level1/A4.1.html>, accessed June 13, 2010. Industries must register (section 126), apply for permits (section 125), pre-treat (section 123), and monitor and report on their discharges (section 127).

¹¹ SFPUC web site, "Fats, Oils & Grease (FOG) Program," http://sfwater.org/mto_main.cfm/MC_ID/14/MSC_ID/118/MTO_ID/229, accessed June 13, 2010.

¹² See <http://sfwater.org/Files/Other/FOGOrdinanceSFPUC022510post.pdf>, accessed June 13, 2010.

¹³ See SF Public Works Code, Article 4.2, <http://library.municode.com/HTML/14142/level1/A4.2.html>, accessed June 13, 2010.

Community Facilities Element

Objective 10: Locate wastewater facilities in a manner that will enhance the effective and efficient treatment of storm and wastewater.

Policy 10.1: Provide facilities for treatment of storm and wastewater prior to discharge into the Bay or ocean. Locate such facilities according to the Wastewater and Solid Waste Facilities Plan.¹⁴

IMPACTS

Significance Criteria

The City and County of San Francisco has not formally adopted significance thresholds for impacts related to wastewater collection and treatment. The Planning Department's Initial Study Checklist provides a framework of topics to be considered in evaluating potential impacts under the California Environmental Quality Act ("CEQA"). Implementation of a project could have significant impacts related to wastewater treatment facilities if it were to:

- Exceed wastewater treatment requirements of the applicable Regional Water Quality Control Board.
- Require or result in the construction of new water or wastewater treatment facilities or expansion of existing facilities, the construction of which could cause significant environmental effects.
- Result in a determination by the wastewater treatment provider that would serve the project that it has inadequate capacity to serve the project's projected demand in addition to the provider's existing commitments.

Issues with No Impacts

Based on the features included in the Proposed Project, there would be no impacts related to the following issues using the significance criteria listed above, and as such, no detailed analyses are necessary.

Wastewater Treatment Requirements

The Proposed Project would include an upgraded or new wastewater treatment plant, replacing the existing plant on Treasure Island. The proposed wastewater treatment plant would be required to meet the provisions of the new NPDES permit issued by the RWQCB in 2010 (see "Existing Wastewater Treatment," p. IV.K.2) or an updated permit if required. (Under the Proposed Project, the SFPUC would continue to operate and maintain the wastewater treatment plant. TIDA would be the permit holder until such time as the

¹⁴ The Wastewater and Solid Waste Facilities Plan noted here in Policy 10.1 is a map that covers only mainland San Francisco. It does not include Treasure Island and Yerba Buena Island; therefore, the map provides no direction related to the Project Area.

wastewater treatment plant and wastewater collection system are accepted into SFPUC's system.

Table IV.O.2: NPDES Permit Effluent Limitations for 2010 through 2015, in Section IV.O, Hydrology and Water Quality, p. IV.O.9, summarizes key effluent limitations in the NPDES permit. The basic purposes of primary and secondary treatment include removing inorganic and organic solids, thereby meeting the NPDES permit's effluent limitations for Total Dissolved Solids and Biochemical Oxygen Demand ("BOD₅"). Under primary treatment, the headworks remove floating solids, grit, and floating oil and grease. A primary sedimentation tank removes settleable solids. This technology has been used successfully for decades. However, to remove suspended solids, including organic solids that would otherwise decompose, and dissolved oxygen from the receiving water, secondary treatment would be used. (It is important to limit the uptake of dissolved oxygen from the receiving water, because fish and other living things in the receiving water depend upon dissolved oxygen.) The proposed secondary treatment includes Trickling Filter/Solids Contact ("TF/SC"). TF/SC has been successfully used since 1979 in the United States, and advancements over the years have improved its effectiveness.¹⁵ TF/SC can typically achieve less than 20 mg/L BOD₅.¹⁶ The NPDES limit is 30 mg/L BOD₅ monthly average and 45 mg/L BOD₅ weekly average; therefore, the TF/SC technology would meet these limits. The closest TF/SC plants to the Proposed Project are located in Hayward and Vallejo, and both are considerably larger than the existing and proposed plants at Treasure Island. Regarding other NPDES permit limits, coliform bacteria would be killed through ultraviolet light, a disinfection method that has become commonly used instead of chlorine, or by chlorination, which is the current disinfection method. Effluent pH (how acidic or how caustic the effluent is) would be addressed through common methods of adding chemicals. In sum, the treatment processes have been well tested in many other locations and are expected to meet the NPDES permit limitations.

Similarly, the proposed wastewater treatment plant and management of the wastewater system would be designed to meet other limitations in the NPDES permit. For example, source control (working to prevent pollutants from entering the wastewater stream) and pretreatment may be effective at reducing copper and cyanide from the wastewater treatment plant effluent. Therefore, the NPDES permit requires a Copper Action Plan and a Cyanide Action Plan, and the SFPUC would implement measures to reduce these pollutants.

¹⁵ Parker, D.S., P.E. Member, and J.R. Bratby, "Review of Two Decades of Experience with TF/SC Process," *Journal of Environmental Engineering*, Vol. 127, No. 5, May 2001, pp. 380-387. A copy of this document is available for public review at the San Francisco Planning Department, 1650 Mission Street, Suite 400, in Case File No. 2007.0903E.

¹⁶ Water Environment Federation and the American Society of Civil Engineers, Environmental and Water Resources Institute, *Water Environment Federation Manual of Practice for the Design of Municipal Wastewater Treatment Plants*, Chapter 15, Integrated Biological Treatment (2010), p. 15-15. A copy of this document is available for public review at the San Francisco Planning Department, 1650 Mission Street, Suite 400, in Case File No. 2007.0903E.

Therefore, the Proposed Project would comply with the wastewater treatment requirements of the RWQCB, and there would be no impact related to this significance criterion.

Wastewater Collection System Facilities

Although the existing wastewater collection system would be inadequate to serve the complete buildout of the Development Program, an entirely new collection system would be part of the Proposed Project, which would meet the requirements of the Proposed Project at full build-out. The proposed wastewater collection system would provide environmental benefits. New and better pipes would reduce infiltration and inflow of groundwater and stormwater into the system and reduce the risk of leaks and breaks. The conceptual design for the new collection system, shown in Figure II.15: Proposed Wastewater Collection System, in Chapter II, Project Description, p. II.57, would have sufficient capacity to accommodate anticipated flows from the Proposed Project. Therefore, there would be no impact regarding adequate capacity of wastewater collection facilities.

Wastewater Treatment Facilities

The Proposed Project would generate about 1.3 mgd of wastewater.¹⁷ By land use, residential uses would generate about 0.9 mgd; retail, commercial, and hotel uses, about 0.2 mgd; and all other uses, about 0.2 mgd. Although the existing wastewater treatment plant does not have the capacity to serve the complete buildout of the Development Program, a new or upgraded wastewater treatment plant is included as part of the Proposed Project. The new or upgraded wastewater treatment plant would have the capacity to treat both the estimated dry weather wastewater flow of 1.3 mgd and the estimated peak wet weather wastewater flow of about 2.9 mgd. Therefore, there would be no impact regarding adequate capacity of wastewater treatment facilities.

Approach to Analysis and Project Features

Typically, EIRs compare the additional flows from the project to the capacity of the existing wastewater infrastructure. In this case, the Proposed Project includes an entirely new or upgraded wastewater system. Pipelines, pump stations, and treatment processes would be specifically designed to provide sufficient capacity to handle anticipated flows.

For the Proposed Project, wastewater generation estimates are based on estimated water demand. Average wastewater flows are based on about 90 to 100 percent of potable water usage,

¹⁷ BKF Engineers, *Treasure Island Infrastructure Update*, (hereinafter “*Infrastructure Update*”), Chapter 8, Addendum, Oct. 7, 2009, Section 8.4.

depending on source.¹⁸ Stormwater runoff from open spaces and streets is not included, because it would be handled by the separate stormwater system. For further information regarding stormwater, see Section K.3, p. IV.K.20.

Proposed Project Facilities

The Proposed Project would treat wastewater on site.¹⁹ As discussed in “G. Proposed Utilities” in Chapter II, Project Description, p. II.56, a Master Wastewater System Plan will be prepared in coordination with the SFPUC. Design criteria for the new or upgraded wastewater treatment facility will be coordinated with the SFPUC. The components of the wastewater system are described below. Further details regarding these components will be set forth in the Master Wastewater System Plan developed in coordination with the SFPUC.

Proposed Wastewater Collection System

The Proposed Project includes a complete replacement (in phases) of the existing wastewater collection system, in part due to its age and condition.²⁰ The conceptual system with estimated pipe sizes is shown on Figure II.15, p. II.57. The existing wastewater collection gravity lines, force mains,²¹ and lift/pump stations would be completely replaced (in phases) with a new collection system. The proposed system would be connected to the existing U.S. Coast Guard and Job Corps systems at their respective property lines.

The proposed collection system would include a series of 8- and 18-inch gravity sewer pipelines and 4-, 8-, 10-, and 15-inch force mains located under the new or rebuilt (in the case of Yerba Buena Island) streets. The existing pipes would be replaced with new pipes meeting City-standard pipe materials for the gravity mains (i.e., vitrified clay pipe) and ductile iron pipe with cathodic protection²² for the force mains, or alternative pipe materials such as High Density Polyethylene (“HDPE”) or PVC if approved by the SFPUC and SFDPW.²³

For Treasure Island, gravity mains would serve the buildings and deliver wastewater to pump stations spaced around the island. The pump stations would use two major force mains to deliver

¹⁸ *Infrastructure Update*, Chapter 8, Section 8.4, July 2010.

¹⁹ TICD, *A Sustainable Future for Treasure Island* (Exhibit K: Sustainability Plan, Oct. 2006) (“2006 TI Sustainability Plan”), p. 59.

²⁰ The Navy installed the wastewater collection system as needed. The system is generally in poor condition, does not comply with the current City and County of San Francisco standards, and needs to be replaced.

²¹ In a force main materials are pumped through the pipeline rather than travelling by gravity.

²² Cathodic protection helps to keep metal pipes from corroding when soil or groundwater in which they are buried contains high levels of salts.

²³ *Infrastructure Update*, Chapter 8, Section 8.3 (July 2010).

wastewater to the treatment plant. One force main would begin in the southwestern portion of the island and flow in a counter-clockwise direction along the western, southern, and eastern edges of the island to the treatment plant. The other force main would begin in the northwest and flow clockwise to the treatment plant.

- Utility service to the Job Corps campus and buildings would be maintained throughout the phased buildout of the Proposed Project. Wastewater service to the Job Corps campus would be more robust under the Proposed Project. Certain modifications for connections of the wastewater pipes would be necessary at the perimeter of the Job Corps site. Details would be worked out during the design process for each major phase.
- The eastern side of Yerba Buena Island would be served by gravity flow to the east, to an existing pump station under the east span of the Bay Bridge. The existing pump station would be repaired or replaced as necessary. This pump station would pump wastewater over to the Treasure Island wastewater collection system through one of two routes: 1) the pump station would deliver wastewater back up to the top of Yerba Buena Island, from which point it would flow by gravity to the Treasure Island system; or 2) the pump station would deliver wastewater to the existing submarine force main that currently serves the eastern side of Yerba Buena Island and connects to the Treasure Island system.²⁴
- Utility service to the Coast Guard Station and Sector Facility would be maintained throughout buildout of the Proposed Project. Certain modifications to the piping connecting to the proposed replacement pump station could be necessary. Details would be worked out during the design process.

The western side of Yerba Buena Island would be served by gravity pipelines that carry flow down from the residences. They would connect to the gravity main from the eastern side, and wastewater would flow down to the pump station at the south end of the causeway, and then to Treasure Island.

On Treasure Island, existing pump stations and lift stations would also be replaced. The conceptual system also includes approximately 10 to 12 pump/lift stations, a reduction from the 27 existing stations. The number of pump/lift stations would depend upon final grading plans, feasible depth of utility trenching, and the geotechnical improvements. Each station would include redundant pumps, emergency warning systems to alert staff of needed repairs, and an emergency generator in case of power outages.

The existing wastewater collection system would be retained to the extent feasible while the new or upgraded system is under construction. Repairs and upgrades to the existing system would be performed as necessary by the SFPUC to keep the system operational until it is replaced.

²⁴ *Infrastructure Update*, Chapter 8, Section 8.3 (December 1, 2008).

Proposed Wastewater Treatment System²⁵

The proposed wastewater treatment system consists of: 1) primary treatment using headworks and primary sedimentation, 2) secondary treatment using trickling filter and solids contact, 3) tertiary treatment with microfiltration and reverse osmosis for a portion of the flow to be used as recycled water (discussed in Section K.2, below), and 4) disinfection either by ultraviolet light or chlorination. Figure IV.K.1: Proposed Wastewater Treatment System, shows the “baseline system.”

The primary treatment process would start with the headworks, consisting of a flow measuring device and self-cleaning fine screens. Next, a primary sedimentation tank would remove settleable solids. Odor control for the plant headworks and primary treatment areas would use up to about 50 gallons per day of sodium hypochlorite solution and up to about 12 gallons per day of caustic (sodium hydroxide) solution to neutralize the hypochlorite.

The secondary treatment process would begin with trickling filters. This process consists of a fixed-film media, where primary effluent is fed to the top of the filter tank. As the flow descends, the biofilm on the filter oxidizes organic material. After the filter, the wastewater would go to a solids contact tank to remove suspended solids. In these tanks, the solids that slough off the trickling filter media are removed (by flocculation). The solids contact tank would typically have one day of solids retention time. The solids would go to a secondary clarifier to settle out and then be returned to the solids contact tank.

The waste solids from the primary and secondary treatment processes would be subjected to anaerobic digestion, in which microorganisms break down organic matter. The resulting solids would be dewatered and then land-applied in Solano County, or disposed of through similar, appropriate reuse means. Odor control for the solids handling facility would use up to about 25 gallons per day of sulfuric acid and up to about 5 gallons per day of caustic solution.

Odor control could be carried out using bioscrubbers instead of chemicals. A bioscrubber is an engineered bed of compost and/or wood chips over perforated pipes. Bacteria grow in the bed of compost and break down odorous chemicals in the air. The bioscrubber beds would take up more space in the treatment plant than would the chemical odor control equipment.

The primary and secondary processes described above would be applied to the entire sanitary sewage flow. Then approximately 0.42 mgd of the treated effluent would be treated further and used as recycled water (see Section K.2, Wastewater Recycling Plant, Storage, and Distribution, p. IV.K.14, for more information about recycled water and additional treatment).

²⁵ As part of the project, TICD would provide a developable pad for a new wastewater treatment plant, to be constructed near the existing plant. The new wastewater treatment plant and recycled water plant would be financed, built, owned, and operated by the SFPUC.

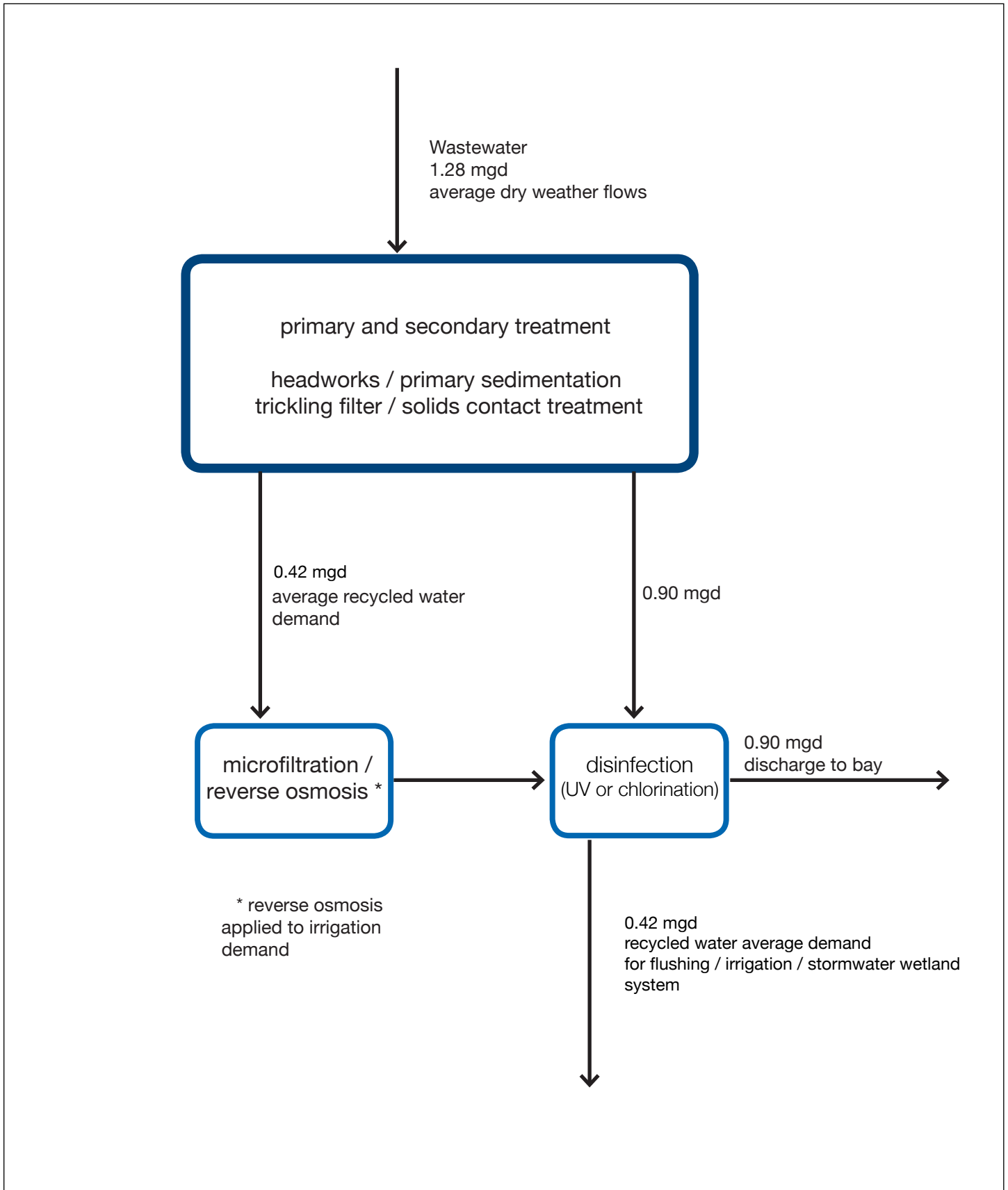

SOURCE: Brown & Caldwell

- The remaining effluent would be disinfected with ultraviolet light or by chlorination and discharged through the existing outfall to the Bay. If chlorination were selected, the treatment plant would use sodium hypochlorite to disinfect, and then sodium bisulfite to dechlorinate the effluent.²⁶

Potential impacts of the wastewater treatment operation are discussed in other sections of the EIR, as appropriate. For example, energy use of wastewater treatment is taken into account in Section IV.Q, Mineral and Energy Resources; see “Proposed Project’s Electricity and Natural Gas Demand,” on p. IV.Q.13. Noise from treatment plant operations is discussed under Impact NO-6, in Section IV.N, Noise, p. IV.N.28.

Two variants of the wastewater treatment system would use wetlands as a step in the treatment process. These wastewater wetlands variants are discussed in more detail in Chapter VI, Project Variants, in “D, Wastewater Wetlands Variants.”

The new or upgraded treatment plant would have the capacity to treat both the estimated project buildout flow of 1.3 mgd (the estimated dry-weather flow), and estimated project peak wet-weather flow of 2.9 mgd.

The existing treatment plant would remain in operation as long as feasible during the first phases of new construction. Portions of the new or upgraded treatment plant would be constructed as needed and as feasible during each phase to meet the flow requirements of the project.

As discussed in “Proposed Wastewater Treatment,” in Chapter II, Project Description, p. II.58, the new or upgraded wastewater treatment facility could include testing and possible use of a variety of new technologies for processing effluent or biosolids as they are developed. The SFPUC would assess the effectiveness of these additions at a demonstration project level.

In addition to constructing and operating the new or upgraded wastewater treatment plant, the SFPUC would have use of an additional 4 to 6 acres near the treatment plant on Treasure Island. The SFPUC would use this property for a range of uses that may include infrastructure improvements furthering the objectives in the proposed *Sustainability Plan*.

- ²⁶ To treat the estimated 1.3 mgd of dry weather flow, about 70,000 dry pounds of sodium hypochlorite and 166,000 dry pounds of sodium bisulfite would be used annually.

Project Impacts

Construction

Impact UT-1: Construction activities associated with wastewater infrastructure for the Proposed Project could result in air quality, noise, water quality, transportation, hazardous materials, and biological impacts, as further evaluated under construction subsections in those EIR topics. (See *significance determinations in other topics.*)

The second significance criterion listed above indicates that the Proposed Project would have a significant adverse effect if it would require, or result in, the construction of new or upgraded

wastewater collection or treatment facilities, where the construction would cause significant environmental effects. Demolition, land clearing, grading, and other ground-disturbing construction activities would temporarily affect local air quality during each phase of construction of the wastewater facilities, causing temporary and intermittent increases in particulate dust and other pollutants. Operation of construction trucks and heavy equipment would create fugitive dust and emit nitrogen oxides, carbon monoxide, reactive organic gases or hydrocarbons, and particulate matter, as a result of diesel fuel combustion. Use of hazardous materials in new construction could result in emissions of toxic air contaminants. Construction activities and heavy equipment would also cause temporary and intermittent increases in noise during each construction phase. Excavation may result in release of volatile contaminants in the ground or groundwater, and excavated soils could contain hazardous materials. Construction activities could pollute run-off from construction areas. Construction trucks and other vehicles could cause transportation impacts on local roads and/or the Bay Bridge. Construction activities could adversely affect biological resources.

These potential impacts of construction, including construction of wastewater infrastructure, are discussed in Section IV.E, Transportation, pp. IV.E.67 – IV.E.71 (Impact TR-1); Section IV.F, Noise, pp. IV.F.14 – IV.F.20 (Impacts NO-1 and NO-2); Section IV.G, Air Quality, pp. IV.G.24-IV.G.38 (Impacts AQ-1 – AQ-4); Section IV.M, Biological Resources, pp. IV.M.41-IV.M.63 (Impacts BI-1 – BI-6); Section IV.O, Hydrology and Water Quality, pp. IV.O.35 – IV.O.41 (Impacts HY-1 – HY-7); and Section IV.P, Hazards and Hazardous Materials, pp. IV.P.39 – IV.P.51 (Impacts HZ-1 – HZ-9).

Operation

Impact UT-2: Wastewater collection system blockages or lift/pump station failures could result in sanitary sewer overflows. (*Less than Significant*)

Sanitary sewer overflows may occur when a lift/pump station fails, if sewer lines become plugged, or if the volume of flows is high enough to overwhelm the system. The current collection system has this risk. Under the Proposed Project, to prevent potential Sanitary Sewer Overflows, the proposed lift/pump stations would include redundant pumps, alarm systems, and emergency back-up power generators. Assuming normal maintenance and monitoring, the pump stations would operate with a very low probability of failure. In addition, replacing the collection system would reduce inflow and infiltration, which in turn would reduce flows during wet weather. Also, the system would be operated in compliance with SWRCB Water Quality Order No. 2006-0003 (Sanitary Sewer Order) which requires public agencies that own or operate sanitary sewer systems to develop and implement sewer system management plans to reduce and eliminate sanitary sewer overflows.

Because of these risk reduction features, the Proposed Project would be expected to have a less-than-significant effect regarding Sanitary Sewer Overflows, and no mitigation is required.

Cumulative Impacts

Impact UT-3: Construction and operation of the Proposed Project would not significantly contribute to cumulative infrastructure deficits or result in the exceedance of wastewater discharge requirements. (*No Impact*)

Treasure Island and Yerba Buena Island have, and would have, “stand-alone” infrastructure. No cumulative infrastructure deficits would be created. In addition, RWQCB requirements would not be exceeded. Therefore, there would be no cumulative impacts regarding wastewater collection and treatment facilities.

K.2 WASTEWATER RECYCLING PLANT, STORAGE, AND DISTRIBUTION

SETTING

Existing Conditions

Wastewater recycling (also called “water recycling”) generally means treating wastewater to the degree that it can be reused for purposes such as landscape irrigation, crop irrigation, toilet flushing, and even drinking.²⁷ Currently, there is no wastewater recycling at Treasure Island or Yerba Buena Island. There is no regulatory requirement that mandates recycling at the existing wastewater treatment plant.

Regulatory Framework

Federal and State laws and local policies govern water quality protection, as explained in Section IV.O, Hydrology and Water Quality, “Regulatory Framework,” p. IV.O.11. Requirements applicable to recycling water are summarized below.

Federal

The Federal Clean Water Act is the primary Federal legislation protecting water quality. The USEPA has delegated certain authority under the Clean Water Act to the SWRCB, as discussed below.

²⁷ “Reclaimed water” means wastewater effluent treated to meet California Department of Public Health standards.

State

California law and the SWRCB encourage the use of recycled water to the maximum extent in order to supplement existing surface and ground water supplies to help meet water needs.²⁸ In 2009, the SWRCB adopted a Recycled Water Policy²⁹ that focuses on increasing the use of recycled water from municipal wastewater sources. The Recycled Water Policy sets Statewide volumetric targets for recycling and describes the relationships between State agencies with jurisdiction over water, with respect to recycling. The SWRCB also approved a general permit for the use of municipal recycled water for landscape irrigation.³⁰ Under the general permit, landscape irrigation uses include parks, greenbelts, and playgrounds; school yards; athletic fields; golf courses; cemeteries; residential landscaping, common areas; commercial landscaping, except eating areas; industrial landscaping, except eating areas; and freeway, highway, and street landscaping.

An entity that proposes to recycle water, or to use recycled water, must file a report with the Regional Water Quality Control Board (“RWQCB”).³¹ If the RWQCB determines that it is necessary to protect public health, safety, or welfare, it may prescribe water recycling requirements and issue a permit.³² The RWQCB must consult with the California Department of Public Health³³ (“CDPH”) when it issues water recycling requirements.³⁴ The CDPH has established statewide recycling criteria for the various uses of recycled water to ensure protection of public health.³⁵ The level of treatment required by the CDPH depends on the potential exposure of human beings to the recycled water. For irrigation of food crops where the recycled water comes into contact with the edible portion of the crop (including root crops), CDPH requires disinfection and tertiary treatment.³⁶ In addition, the recycled water must have any other impurities removed that would detract from the intended use. At Treasure Island, intrusion of

²⁸ California Water Code Sections 13510-13512.

²⁹ SWRCB, Recycled Water Policy (2009), http://www.swrcb.ca.gov/water_issues/programs/water_recycling_policy/docs/recycledwaterpolicy_approved.pdf, accessed on April 13, 2010.

³⁰ SWRCB, Water Quality Order No. 2009-0006-DWQ, “General Waste Discharge Requirements for Landscape Irrigation uses of Municipal Recycled Water (General Permit) (2009), http://www.swrcb.ca.gov/water_issues/programs/water_recycling_policy/landscape_irrigation_general_permit.shtml, accessed April 13, 2010.

³¹ California Water Code Section 13522.5.

³² California Water Code Section 13523.

³³ The California Department of Health Services (“DHS”) was reorganized, and the pertinent regulatory authority now lies within the California Department of Public Health.

³⁴ California Water Code Section 13523.

³⁵ California Code of Regulations, Title 22, Division 4, Chapter 3, Sections 60301, *et seq.* (referred to as “Title 22” in subsequent footnotes in this Recycled Water subsection of the EIR.)

³⁶ Title 22, Section 60304(a).

saltwater into the sewers increases the salinity of collected sewage. The excess chlorides in salt means the treated wastewater could be detrimental to plants unless chloride is removed.³⁷

In 2007, the State passed AB 1406, amending Section 13553 of the California Water Code, and authorizing the use of recycled water for toilet and urinal flushing in condominium projects created after January 1, 2008, subject to specified conditions as follows: (a) potable water service to the condominium project has a backflow protection device approved by the State to protect the public, potable water supply; (b) plumbing modifications are done in accordance with plumbing codes; (c) a condominium project's potable and nonpotable systems must be tested at least every four years for cross-connections; (d) recycled water lines must be color coded; (e) notices of the use of recycled water must be provided to buyers and owners; and other conditions.³⁸

Local

In 1991, the SFPUC sponsored and the San Francisco Board of Supervisors passed a Reclaimed Water Use Ordinance requiring the Water Department (now part of the SFPUC) and the Department of Public Works to prepare a coordinated, comprehensive citywide plan for the efficient expansion of the use of reclaimed water and groundwater sources.³⁹ It also generally requires development projects over 40,000 sq. ft. to build and operate a reclaimed water system within the buildings and a reclaimed water irrigation system for the landscaping.⁴⁰ The City also restricts use of potable water for soil compaction and dust control activities for construction and demolition purposes.⁴¹

The SFPUC has a recycled water program and aims to develop irrigation projects, such as the Westside Recycled Water Project (which would serve Golden Gate Park and other areas) and Harding Park Golf Course.⁴² Use of recycled water is an integral part of the SFPUC's Water System Improvement Program; this program is discussed in more detail below under "K.4 Water Supply and Distribution System (Potable and Fire-Fighting)," p. IV.K.38.

³⁷ Brown and Caldwell, *Evaluation of Wastewater and Recycled Water Treatment Alternatives for the Proposed Treasure Island Development (Revised Draft)*, August 13, 2006, p. 9.

³⁸ California Water Code Section 13553(d).

³⁹ San Francisco Public Works Code, Article 22, <http://library.municode.com/HTML/14142/level1/A22.html>, accessed June 15, 2010.

⁴⁰ *Ibid*, section 1204.

⁴¹ San Francisco Public Works Code, Article 21, <http://library.municode.com/HTML/14142/level1/A21.html>, accessed June 15, 2010.

⁴² SFPUC web site, "Recycled Water Program," http://sfwater.org/msc_main.cfm/MC_ID/13/MSD_ID/375, accessed April 13, 2010.

IMPACTS

Significance Criteria

The City and County of San Francisco has not formally adopted significance standards for impacts related to utilities, including wastewater recycling. The Planning Department's Initial Study Checklist form provides a framework of topics to be considered in evaluating potential impacts under CEQA. Implementation of a project could have significant impacts related to wastewater recycling facilities if it were to:

- Require or result in the construction of new water or wastewater treatment facilities or expansion of existing facilities, the construction of which could cause significant environmental effects.

Approach to Analysis

No recycled water is currently produced or used in the Project Area. Therefore, the analysis of recycled water does not compare existing to proposed recycled water production or use. Rather, the analysis discusses the effect that use of recycled water would have on the Proposed Project's overall water demand.

Proposed Project Facilities

The use of recycled water for irrigation and other purposes is a major component of the *Treasure Island Sustainability Plan*.⁴³ Recycled water would be used to irrigate open space areas, the Urban Agricultural Park, roadside plantings, and landscape water features, and for appropriate plumbing fixtures in commercial buildings and residential buildings on Treasure Island to the extent permitted at the time of construction. Recycled water may also be used to maintain water levels in the stormwater treatment wetlands during the dry season. (See "K.5, Stormwater Collection and Treatment," regarding the proposed stormwater treatment wetlands.) The estimated average daily demand for recycled water for the above listed uses on Treasure Island is about 420,000 gallons per day.⁴⁴

As discussed in Chapter II, Project Description, p. II.60, a detailed Master Recycled Water Plan will be prepared in accordance with SFPUC rules and requirements. Under the Development Program, a developable pad would be provided for the new recycled water plant. The recycled water plant would be constructed and operated by the SFPUC. The Master Recycled Water Plan will include the recycled water facility design requirements, detailed layouts and hydraulic

⁴³ 2006 *Treasure Island Sustainability Plan*, p. 59. In addition, Strategy W5 is, "Maximize use of recycled water."

⁴⁴ *Infrastructure Update*, Chapter 7, Table 7.2, addendum, October 8, 2009, Section 7.2.1

calculations for the recycled water system, and system phasing plans. The overall recycled water program is described below.

- As described in “Proposed Wastewater Treatment System,” on p. IV.K.10, the entire sanitary sewage flow would undergo primary and secondary treatment and disinfection at the wastewater treatment facility. The portion of the secondary effluent that would be used for recycled water would go through an additional (“tertiary”) treatment step at the facility’s recycled water plant. This step would involve microfiltration and, to the extent required, reverse osmosis. This effluent would meet California standards for recycled water.

Microfiltration employs a membrane with a pore size of approximately 0.1 micron. Solids accumulate on the membrane, and from time to time, the flow is reversed to remove the collected solids. The backwash would be directed to the headworks. Routine chemical cleaning would be necessary to remove foulants and maintain permeability.

Reverse osmosis would deal with the potential problem of saltwater intrusion into the wastewater collection system. Reverse osmosis involves a membrane separation treatment. The flow is pumped at high pressure across a membrane surface, producing an effluent with very low salt concentrations (e.g., about 98 percent salt removal). The salts are discharged as a concentrate. Engineers for the Proposed Project estimate that about 80 percent of the resulting tertiary treated effluent would be suitable for use as recycled water.⁴⁵ The remaining approximately 20 percent would be discharged to the Bay through the existing outfall with the treated wastewater effluent. Routine chemical cleaning would be necessary to remove foulants and maintain permeability.

- Reverse osmosis would be used when needed to remove salts. Ultraviolet light or chlorination would be used to disinfect the recycled water.

The recycled water plant would be large enough to meet the average long-term demand (estimated to range up to approximately 0.42 mgd, if residential toilet flushing is approved as a use for recycled water in all buildings, not just condominiums). An additional 0.84 million gallons of recycled water would be available as a supplemental source of firefighting water supply. (See Section K.4 for a description.) A 1.26-million-gallon storage tank would be constructed next to the recycled water plant.

During the initial phases of development and construction of the recycled water plant, potable water would be used when irrigation demand exceeds the supply of recycled water. The temporary connection of the potable water system to the recycled water distribution system would include a backflow prevention device approved by the SFPUC.⁴⁶

⁴⁵ *Infrastructure Plan*, Appendix G, “Treasure Island Description of Wastewater Treatment Alternatives,” p. 2 of 5.

⁴⁶ *Infrastructure Update*, Chapter 9, revision, August 25, 2009, Section 9.2.2.

Distribution piping for recycled water would be provided throughout Treasure Island, but not on Yerba Buena Island. Recycled water is not proposed to be supplied to Yerba Buena Island due to the island's distance from the recycled water treatment plant and the pumping that would be required to reach its high elevations. See Figure II.16: Proposed Recycled Water Distribution System, in Chapter II, Project Description, p. II.62. Distribution pressure and flow requirements would be met with a hydro-pneumatic pressure system constructed near the storage tank at the recycled water plant. The pipe material would be selected to meet SFPUC requirements.

The Proposed Project assumes that recycled water would be used in residential buildings for toilet flushing to the extent permitted by applicable State and local laws and regulations. It is assumed that residential buildings would provide the necessary piping to allow that future use, along with any other recycled water use to the extent authorized at the time of construction, and the estimates for recycled water production outlined above would generate sufficient recycled water to support residential toilet flushing at a minimum. The *Water Supply Assessment* for the Proposed Project, described on p. IV.K.55, analyzed the Proposed Project both with and without use of recycled water.

- The California Department of Housing and Community Development allows the use of gray water (water from sinks, showers, and similar sources, captured for local reuse) in residential buildings under certain circumstances.⁴⁷ Use of gray water is not part of the Proposed Project at this time; any future proposed use of gray water would conform to all applicable state and local requirements. Because it is not known where or whether these gray water sources would be used, they are not evaluated further in this EIR.

Project Impacts

Construction

Impact UT-4: Construction activities associated with the Proposed Project's recycled water infrastructure could result in air quality, noise, water quality, transportation, hazardous materials, and biological impacts, as further evaluated under those EIR topics. (See significance determinations in other topics.)

-
- ⁴⁷ California Code of Regulations, Title 24, Part 5, Chapter 16A, available via Oasis Design (web site), "California Graywater Standard: Chapter 16A Nonpotable Water Reuse Systems," (with link to PDF of official text), available at <http://www.oasisdesign.net/greywater/law/california/currentcode/>, accessed Nov. 7, 2010. A few highlights are: (1) A gray water system limited to reuse of clothes washer water does not require a permit. Section 1603A.1.1. (2) "Simple systems" with a discharge of 250 gallons per day or less require a construction permit, unless exempted by the local enforcing agency. Section 1603A.1.2. (3) "Complex systems" are all other systems and may have more restrictions on them than the first two types of systems. Section 1603A.1.3.

IV. Environmental Setting and Impacts
K. Utilities and Service Systems

The significance criterion on p. IV.K.17 indicates that the Proposed Project would have a significant adverse effect if it would require, or result in, the construction of new or upgraded wastewater recycling facilities, where the construction would cause significant environmental effects. Demolition, land clearing, grading, and other ground-disturbing construction activities would temporarily affect local air quality during each construction phase, causing temporary and intermittent increases in particulate dust and other pollutants. Operation of construction trucks and heavy equipment would create fugitive dust and emit nitrogen oxides, carbon monoxide, sulfur dioxide, reactive organic gases or hydrocarbons, and particulate matter, as a result of diesel

fuel combustion. Use of hazardous materials in new construction could result in emissions of toxic air contaminants. Construction activities and heavy equipment would also cause temporary and intermittent increases in noise during each construction phase. Excavation may result in release of volatile contaminants in the ground or groundwater, and excavated soils could contain hazardous materials. Construction activities could pollute rainwater run-off from construction areas. Construction trucks and other vehicles could cause transportation impacts on local roads and/or the Bay Bridge. Construction activities could adversely affect biological resources.

Impacts of construction, including recycled wastewater facilities, and any relevant mitigation measures are discussed in Section IV.E, Transportation, pp. IV.E.67 – IV.E.71 (Impact TR-1); Section IV.F, Noise, pp. IV.F.14 – IV.F.20 (Impacts NO-1 and NO-2); Section IV.G, Air Quality, pp. IV.G.24-IV.G.38 (Impacts AQ-1 – AQ-4); Section IV.M, Biological Resources, pp. IV.M.41-IV.M.63 (Impacts BI-1 – BI-6); Section IV.O, Hydrology and Water Quality, pp. IV.O.35 – IV.O.41 (Impacts HY-1 – HY-7); and Section IV.P, Hazards and Hazardous Materials, pp. IV.P.39 – IV.P.51 (Impacts HZ-1 – HZ-9).

Operation

Impact UT-5: New recycled wastewater treatment and collection facilities would provide recycled water to reduce the Proposed Project's water demand in conformance with City policies. (No Impact)

The Proposed Project's provision of up an average of 420,000 gallons per day of recycled water, to be used for landscape irrigation and non-potable plumbing demands in commercial buildings, would reduce the daily demand for potable water from about 1.6 mgd to about 1.2 mgd. This would be a beneficial impact on regional water supplies. The operation of the proposed wastewater recycling plant, including the proposed uses of recycled water, would have to meet any permit requirements imposed by the RWQCB. In addition, they would have to meet the public health-related requirements of the CDPH, as would be imposed by the RWQCB permit, and the City's recycled water rules and requirements. The CDPH requirements address the use of recycled water on crops meant for human consumption, such as those grown at the proposed Urban Agricultural Park. Therefore, no adverse environmental or public health impacts from the production or use of recycled water would be anticipated, and no mitigation is required.

Cumulative Impacts

Impact UT-6: Construction and operation of the Proposed Project including the recycled water plant would not significantly contribute to any cumulative impacts. (No Impact)

There would be no cumulative impacts regarding recycled water infrastructure.

K.3 STORMWATER COLLECTION AND TREATMENT

SETTING

Existing Stormwater Collection System

The SFPUC maintains and operates the stormwater collection system. Unlike most of San Francisco, Treasure Island has separate wastewater and stormwater collection systems. Some of the essential features of the existing stormdrain system are shown in Figure IV.K.2: Existing Stormdrain System. The existing stormwater collection system consists of 6- to 42-inch gravity

(text continues on p. IV.K.23)

LEGEND

◆ EXISTING OUTFALL

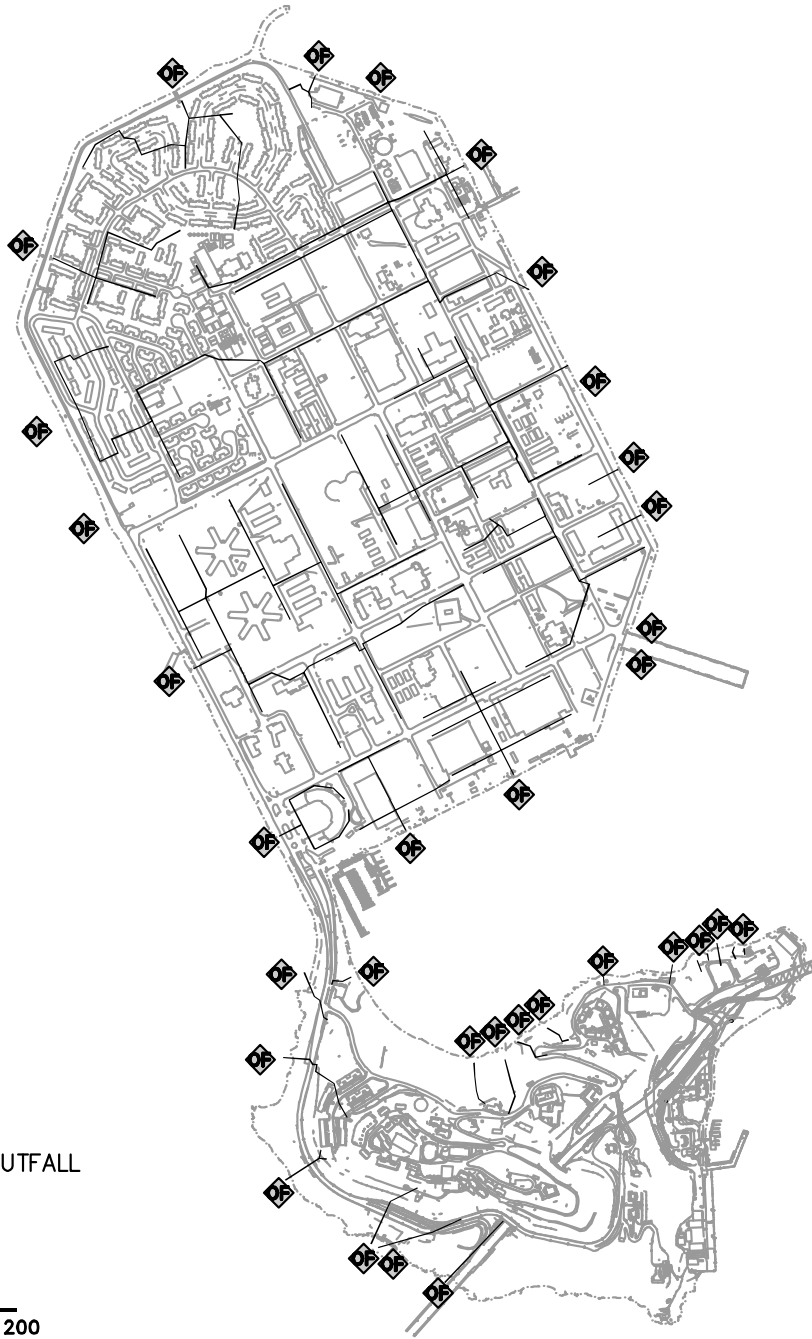
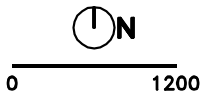

SOURCE: BKF

pipes and lift stations⁴⁸ with outfalls of various sizes along the perimeters of the Islands. Pipes are made of PVC, asbestos cement, vitrified clay, reinforced concrete, and steel.⁴⁹

The outfalls discharge directly into San Francisco Bay. Treasure Island has approximately 31 outfalls, and Yerba Buena Island has approximately 32 outfalls. Currently, stormwater is not treated before it is discharged to the Bay.

Regulatory Framework

Federal and State laws and local policies govern water quality protection, as explained in Section IV.O, Hydrology and Water Quality, “Regulatory Framework,” p. IV.O.11. Applicable requirements described in that subsection are summarized below, along with additional information.

Federal

The Federal Clean Water Act addresses pollution from non-point sources, and includes managing such pollution through NPDES permits. The EPA has authority to issue NPDES permits for several categories of stormwater discharges, including discharges associated with industrial activity; discharges from municipal dischargers with populations equal to or exceeding 100,000; and discharges judged by the permitting authority to be significant sources of pollutants or which contribute to a violation of a water quality standard.⁵⁰ Under this authority, the EPA requires municipal stormwater dischargers to obtain a municipal discharge permit for stormwater runoff.⁵¹ The EPA has issued a general NPDES permit⁵² for construction sites that would disturb 1 or more acres.⁵³ The EPA has also issued a general NPDES permit (called the multi-sector general permit) for industrial facilities other than construction sites.⁵⁴

⁴⁸ Lift stations lift the stormwater up to a level where it can flow by gravity. Pump stations put stormwater in pipes under pressure; such pipes are called force mains.

⁴⁹ *Infrastructure Update*, Chapter 10, Section 10.1 (December 1, 2008).

⁵⁰ Federal Clean Water Act section 402(p), added by the 1987 Water Quality Act.

⁵¹ See, e.g., 40 Code of Federal Regulations part 122.26.

⁵² Agencies use “general permits” because they save time and resources in dealing with a large number of facilities or sources that common elements. “In addition, the use of a general permit ensures consistency of permit conditions for similar facilities.” SWRCB, “National Pollution Discharge Elimination System (NPDES)” web page, http://www.waterboards.ca.gov/water_issues/programs/npdes/, accessed April 13, 2010.

⁵³ 73 Federal Register 40338, July 14, 2008. This permit is a reissuance of the previous permit which was issued on July 1, 2003. See <http://www.epa.gov/region09/water/npdes/stormwater.html>, accessed April 13, 2010.

⁵⁴ 73 Federal Register 56572, September 29, 2008. The permit is a reissuance of the previous multi-sector general permit which was issued on October 30, 2000. See <http://www.epa.gov/region09/water/npdes/stormwater.html>, accessed April 13, 2010.

State

Municipal Separate Stormwater Sewer Systems (“MS4”) in San Francisco are subject to the Small Municipal Separate Storm Sewer System General Permit (General Permit, CAS000004) adopted by the SWRCB in 2003. The City and County of San Francisco is covered by the Phase II MS4 NPDES program, because the population served by separate stormwater sewers is less than 100,000. NPDES permits are valid for 5 years, and the Small MS4 General Permit expired in 2008. However, the permit remains in effect while the SWRCB revises the permit. As of December 2009, the SWRCB is gathering public input on a draft revised permit, and it is unclear when it will adopt the final permit.⁵⁵

Under the draft MS4 NPDES permit, the volume-based design criterion for a structural Best Management Practice (“BMP”) is to treat 80 percent of annual runoff volume, which in San Francisco is a rainfall depth of approximately 0.70 inch.⁵⁶ The flow-based design requirement is to treat flow resulting from two times the 85th percentile storm (or 0.20 inch/hour).⁵⁷

As explained in Section IV.O, Hydrology and Water Quality, “Regulatory Framework,” p. IV.O.17, the SWRCB adopted a new General Construction Activity Permit for Discharges of Storm Water Runoff Associated with Construction Activity, on September 2, 2009, for construction activities that would disturb 1 acre or more of land.

The RWQCB also implements the Water Quality Control Plan for the San Francisco Bay Basin (Basin Plan), which has policies geared to protecting the beneficial uses of the Bay, such as recreation, industrial water supply, fishing, navigation, and wildlife habitat.⁵⁸

Local

As explained in Section IV.O, Hydrology and Water Quality, “Regulatory Framework - Local,” on p. IV.O.20, the SFPUC has a Water Pollution Prevention Program and a Stormwater Management Plan.⁵⁹ Both of these strive to reduce stormwater pollution. The SFPUC’s Urban Watershed Management Program oversees implementation of the Stormwater Design Guidelines.

⁵⁵ Memorandum from Christian Nilsen, Philip Williams & Associates, Ltd. (PWA) and Chris Guillard, Conger Moss Guillard, to Treasure Island EIR team, re: “Treasure Island stormwater treatment update and supplementary materials,” dated Dec. 1, 2009 (hereinafter “*Memorandum: Treasure Island Stormwater Update, Dec. 1, 2009*”), p. 2. A copy of this document is available for public review at the San Francisco Planning Department, 1650 Mission Street, Suite 400, in Case File No. 2007.0903E.

⁵⁶ *Memorandum: Treasure Island Stormwater Update*, Dec. 1, 2009, p. 3.

⁵⁷ *Ibid.*

⁵⁸ SFRWQCB, *Water Quality Control Plan for the San Francisco Bay Basin* (2007).

⁵⁹ See the cited pages of Section IV.O, Hydrology and Water Quality, for citations to Articles 4, 4.1, and 4.2 of the San Francisco Public Works Code.

As required by the NPDES General Permit, the SFPUC developed a Citywide stormwater management plan. Stemming from that effort, the SFPUC and the Port of San Francisco developed the San Francisco *Stormwater Design Guidelines*, for areas with separated sanitary and storm sewers, such as Treasure Island.⁶⁰ The guidelines set forth a planning process for stormwater management and guidance for developing integrated, Low Impact Design (“LID”) solutions using site- and neighborhood-scale BMPs. The *Stormwater Design Guidelines* include seven principles:

- 1) Preserve and protect existing waterways, wetlands, and vegetation.
- 2) Preserve natural drainage patterns and topography and use them to inform design.
- 3) Think of stormwater as a resource, not a waste product.
- 4) Minimize and disconnect impervious surfaces.
- 5) Treat stormwater at its source.
- 6) Use treatment trains to maximize pollutant removal.
- 7) Design the flow path of stormwater on a site all the way from first contact to discharge point.

Under the *Stormwater Design Guidelines*, the volume-based design criterion for a structural BMP is to treat 90 percent of annual runoff volume, which in San Francisco is a rainfall depth of approximately 0.75 inch.⁶¹ This performance measure has been approved by the RWQCB for use in San Francisco. For flow-based designs, BMPSs would be designed to accommodate a 0.2 inch per hour rainfall event, equivalent to the requirement contained in the City’s NPDES stormwater discharge permit.⁶²

In addition, under the Stormwater Control Ordinance,⁶³ every development project must have a stormwater control plan that meets the criteria in the *Stormwater Design Guidelines*.⁶⁴ The Ordinance provides for inspections, sampling, notification regarding spills, and enforcement.⁶⁵

The Environmental Protection Element and Community Facilities Element of the *San Francisco General Plan* contain objectives and policies relating to wastewater facilities:

⁶⁰ San Francisco Public Utilities Commission and Port of San Francisco, *Stormwater Design Guidelines*, released February 24, 2009. The final *Stormwater Design Guidelines* can be found at: http://sfwater.org/mto_main.cfm/MC_ID/14/MSC_ID/361/MTO_ID/543, accessed June 15, 2010. The SFPUC adopted the guidelines on January 12, 2010.

⁶¹ *Memorandum: Treasure Island Stormwater Update*, December 1, 2009, pp. 3-4.

⁶² Sarah Minick, SFPUC, personal communication with Christian Nelson, P.E., Philip Williams Associates, March 18, 2010.

⁶³ Ordinance No. 83-10 (amending the San Francisco Public Works Code). See, SFPUC, Stormwater Design Guidelines web page, http://www.sfwater.org/mto_main.cfm/MC_ID/14/MSC_ID/361/MTO_ID/543, accessed June 16, 2010. The Stormwater Control Ordinance is available via a link at the top of this web page.

⁶⁴ Stormwater Control Ordinance, Section 147.2.

⁶⁵ Stormwater Control Ordinance, Section 147.4.

Environmental Protection Element

Objective 3: Maintain and improve the quality of the Bay, ocean and shoreline areas.

Policy 3.1: Cooperate with and otherwise support regulatory programs of existing regional, State, and Federal agencies dealing with the Bay, Ocean, and Shorelines.

Policy 3.3: Implement plans to improve sewage treatment and halt pollution of the Bay and Ocean.

Community Facilities Element

Objective 10: Locate wastewater facilities in a manner that will enhance the effective and efficient treatment of storm and wastewater.

Policy 10.1: Provide facilities for treatment of storm and wastewater prior to discharge into the Bay or ocean. Locate such facilities according to the Wastewater and Solid Waste Facilities Plan.⁶⁶

IMPACTS

Significance Criteria

The City and County of San Francisco has not formally adopted significance standards for impacts related to utilities, including storm drainage. The Planning Department's Initial Study Checklist provides a framework of topics to be considered in evaluating potential impacts under CEQA. Implementation of a project could have a potentially significant impact related to stormwater facilities if it were to:

- Exceed wastewater treatment requirements of the applicable Regional Water Quality Control Board.
- Require or result in the construction of new water or wastewater treatment facilities or expansion of existing facilities, the construction of which could cause significant environmental effects.
- Require or result in the construction of new storm water drainage facilities or expansion of existing facilities, the construction of which could cause significant environmental effects.

Approach to Analysis

The existing stormwater drainage on Treasure Island and Yerba Buena Island conveys runoff directly to the Bay without treatment. Pollutants in stormwater are, and would continue to be typical of urban runoff, with coarse sediments, soluble pollutants like plant nutrients, oil and

⁶⁶ The Wastewater and Solid Waste Facilities Plan noted here in Policy 10.1 is a map that covers only mainland San Francisco. It does not include Treasure Island and Yerba Buena Island; therefore, the map provides no direction related to the Project Area.

grease, and heavy metals. The Proposed Project includes stormwater collection and treatment facilities that would reduce or remove these pollutants, as described below.

The proposed stormwater collection facilities would be designed to comply with the requirements of the City's NPDES permit and sized to meet the SFPUC standards. Therefore, there would be no impact regarding adequacy of stormwater collection capacity, and this issue does not require further discussion or analysis.

Proposed stormwater treatment processes would be based on the SFPUC's *Stormwater Design Guidelines* and would meet the RWQCB treatment requirements in the City's NPDES permit. The BMPs would be more than what is typically made available to treat stormwater runoff, and would meet or exceed the requirements in the City's existing MS4 permit. The Proposed Project would not exceed the wastewater treatment requirements of the RWQCB; therefore, there would be no impact related to stormwater treatment requirements, and this issue does not require further discussion.

Controlling stormwater pollution from rainwater runoff from streets and buildings depends upon a wide variety of approaches. Regulatory agencies have provided mandatory approaches and also an extensive menu of recommended BMPs. Evaluating whether the Proposed Project would sufficiently control stormwater pollution is done by comparing the approaches incorporated in a project with agency mandated approaches and recommended BMPs.

Proposed Project Facilities

A goal in the *Sustainability Plan* for Treasure Island is to treat stormwater on site.⁶⁷ As discussed in Chapter II, Project Description, p. II.61, a Master Storm Drainage Plan and Stormwater Control Plan would be developed in accordance with SFPUC rules and regulations. The Stormwater Control Plan would cover all three levels of stormwater management planning: site design, source control, and structural BMPs.⁶⁸ The basic stormwater collection and treatment systems are described below.

Proposed Stormwater Collection System

The existing stormwater collection system would be replaced with a new collection system, in phases, which would include gravity pipelines, force mains, lift stations, pump stations, and new outfalls to the Bay. Figure II.17: Proposed Stormwater Collection System, in Chapter II, Project Description, p. II.63, shows the preliminary pipeline sizing and approximate locations of the pump station and outfalls.

⁶⁷ 2006 *Treasure Island Sustainability Plan*, p. 59.

⁶⁸ *Memorandum: Treasure Island Stormwater Update*, December 1, 2009, p. 1.

- The proposed stormwater drainage collection system would be a combination of gravity lines, lift stations, pump stations, and outfalls to the Bay. The stormwater drainage collection system would be designed to meet the following criteria:
 - Maintain the hydraulic grade line (“HGL”) in general 2-feet, but no less than 1-foot, below pavement grades in new building areas during 5-year rain event and 100-year tide.
 - Storm frequency larger than 5-year allowed to run in streets as overland flow.
 - In open space areas, maintain HGL below grade during an average year rain event and 100-year tide elevation. Ponding would be allowed in the open space areas for larger rain events during a 100-year tide.
 - Outfalls designed to handle 100-year overland release and wave overtopping.

The gravity pipelines would range from about 12 inches to 60 inches and would follow the proposed road layout on Treasure Island. Some of these pipes would direct flow to outfalls. The stormwater flow from the western side of Yerba Buena Island would be directed to two new outfalls and also to a gravity pipeline along the causeway to Treasure Island.

A pump station in the northwestern corner of Treasure Island would push flow through a 15-inch force main to the treatment wetlands in the northeast quadrant of Treasure Island. Similarly, a pump station on the eastern side of Treasure Island would direct a portion of the stormwater to the same treatment wetlands. The treatment wetlands are discussed below.

The pipe materials would be a combination of reinforced concrete for gravity pipelines and ductile iron with cathodic protection for the two proposed force mains.⁶⁹ HDPE pipes could be used if approved by the SFPUC.

The storm drain pipes would be sized to accommodate rainwater flows from a 5-year storm. Stormwater flows resulting from a rainfall of 0.2 inch per hour (“treatment flows”) would be directed through gravity and/or by pump stations to treatment areas. Flows larger than the treatment flows, up to the 5-year storm event, would flow in the pipes, bypassing the treatment devices, and flow directly to the Bay.

Flows larger than 5-year storm events would flow overland through the streets of the Project Area toward the open spaces around the perimeter of Treasure Island and Yerba Buena Island. The flows would collect in these areas and drain out to the Bay through overflow release or inlets attached to the 12 proposed new consolidated outfall structures serving Treasure Island and two serving Yerba Buena Island.

- The Proposed Project is designed so as not to cause overland storm drainage onto the Job Corps site from the areas to be developed. Overland storm drainage release from the Job Corps

⁶⁹ *Infrastructure Update*, Chapter 10, Section 10.2.2 (December 1, 2008).

- campus and buildings would be maintained through the use of pump stations. The existing Job Corps pump station may need to be modified or relocated. Drainage from the Job Corps campus and buildings would be maintained during construction and permanently thereafter. Certain modifications to the storm drain system would be necessary at the perimeter of the Job Corps site. Details would be worked out during the design process.

The inlets and outfalls would be sized to accommodate the 100-year storm, and to account for higher tide elevations due to potential, future sea level rise.⁷⁰ The outfall structures on Treasure Island would include a combination of an inlet sized to accommodate the 100-year overland release flow, a structure containing a “Tideflex” device to keep Bay water from backing up into the system during high tides, and an outfall structure into the Bay.⁷¹ Figure IV.K.3: Storm Drain Outfall – Plan View, and Figure IV.K.4: Storm Drain Outfall – Section, provide a conceptual design of the proposed outfall structures.

In some locations, the outfall locations would be designed to accommodate additional pump stations that could be installed in the future to respond potential future sea level rise.

Proposed Stormwater Treatment System - Treasure Island

A portion of the proposed stormwater system is shown in Figure IV.K.5: Proposed Stormwater Treatment Wetland. The proposed stormwater treatment system is based on SFPUC and RWQCB requirements. Treatment is required to the maximum extent practicable, by applying recommended BMPs.

Because the Proposed Project would have separate sanitary and stormwater sewers, the SFPUC’s Stormwater Management Plan and Stormwater Control Ordinance would apply. The Plan requires that BMPs be applied.

BMP selection and treatment strategies for each area are described below. Additional BMPs incorporated within the vertical development parcels and buildings would be considered supplemental additions to the treatment train and would not be required, except in cases where adequate treatment would not be provided to the maximum extent practicable in the horizontal infrastructure. All BMPs would be designed to comply with the Stormwater Management Ordinance and Stormwater Design Guidelines. In addition to localized BMPs, and block-scale to neighborhood-scale treatment measures, the system also includes a stormwater treatment wetland.

⁷⁰ The stormdrain system would be designed based on the current 100-year tide elevation. If sea level rise increases to a point where the 5-year rain event does not stay below ground on Treasure Island, the storm drain system would need to be retrofitted with pump stations at the outfalls. Therefore, the outfalls would be designed to accommodate addition of pump stations in the future, if required. *Infrastructure Update*, Chapter 10, section 10.2.4, (December 1, 2008).

⁷¹ *Infrastructure Update*, Chapter 10, Section 10.2.4, (December 1, 2008).

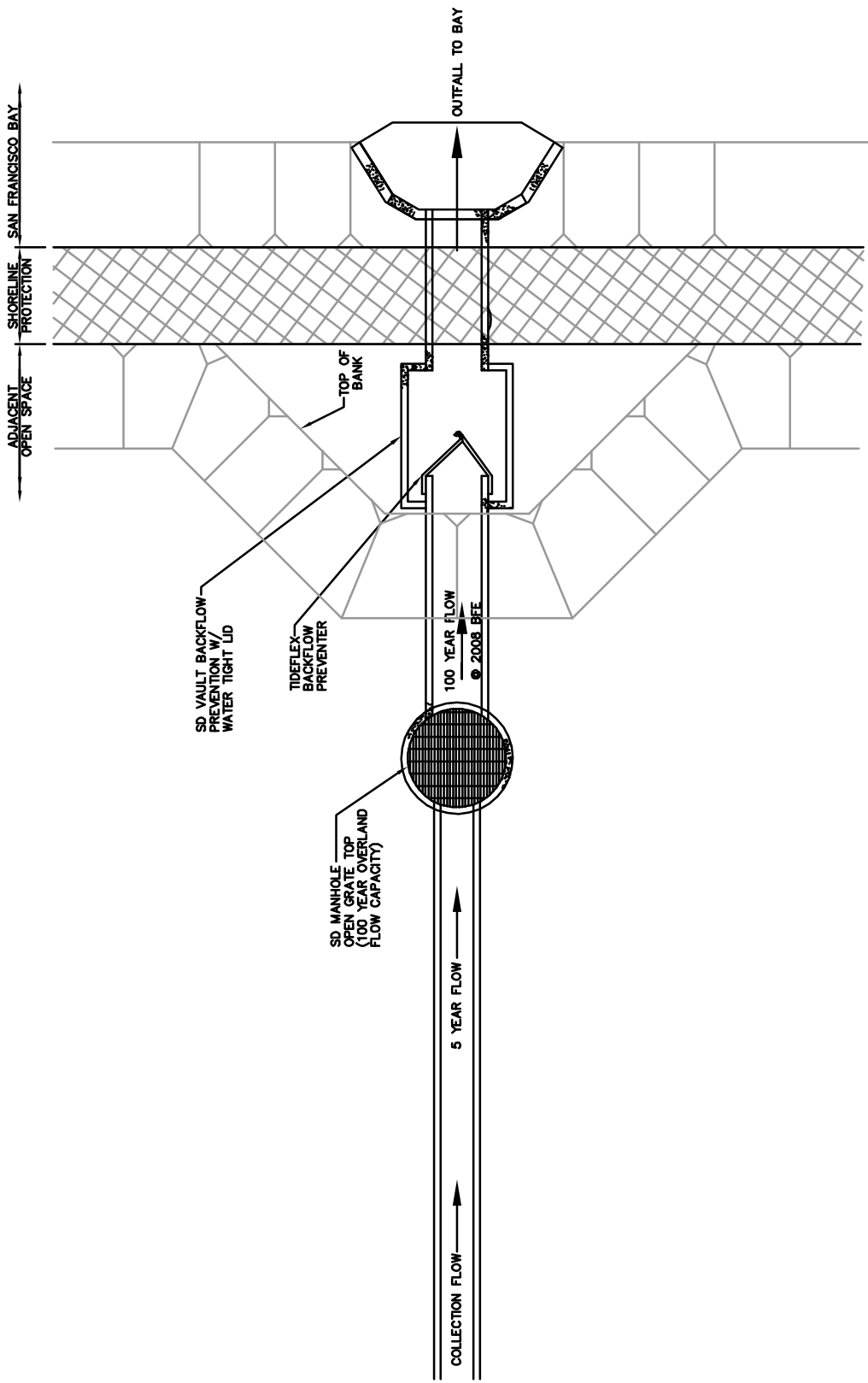

NOT TO SCALE

SOURCE: BKF

FIGURE IV.K.3: STORM DRAIN OUTFALL - PLAN VIEW

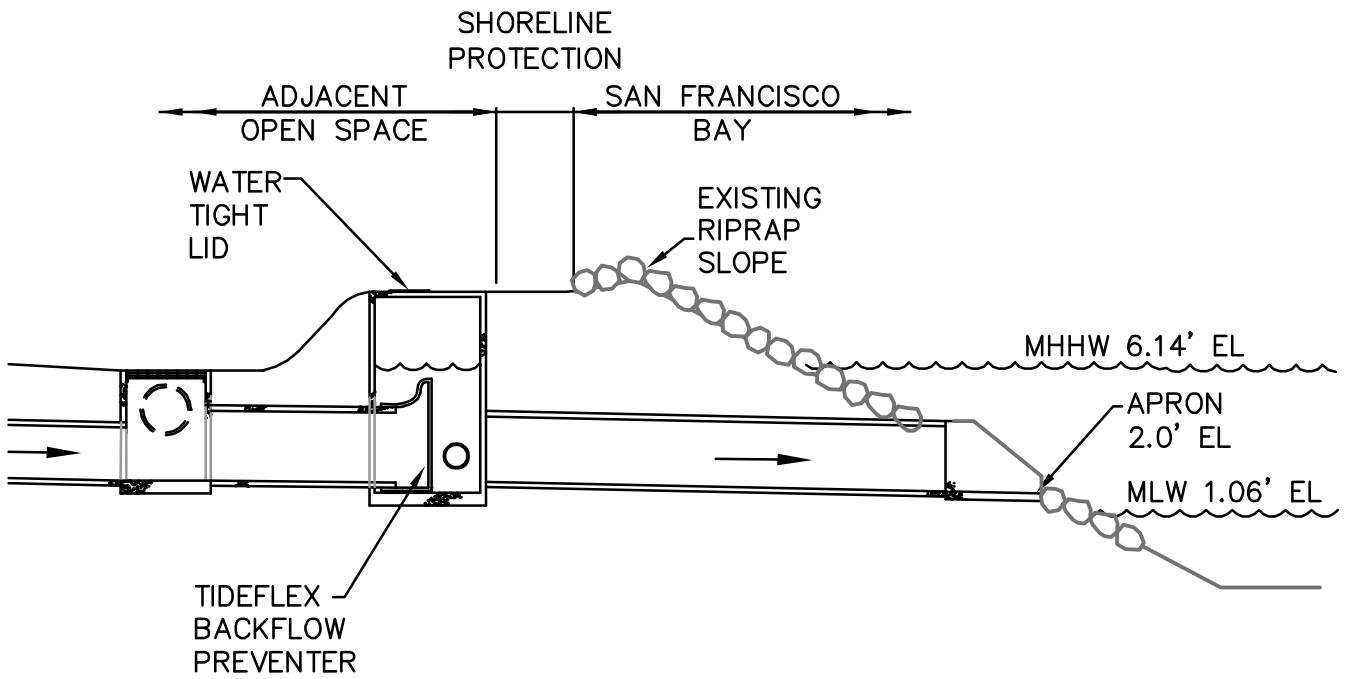

NOT TO SCALE

SOURCE: BKF

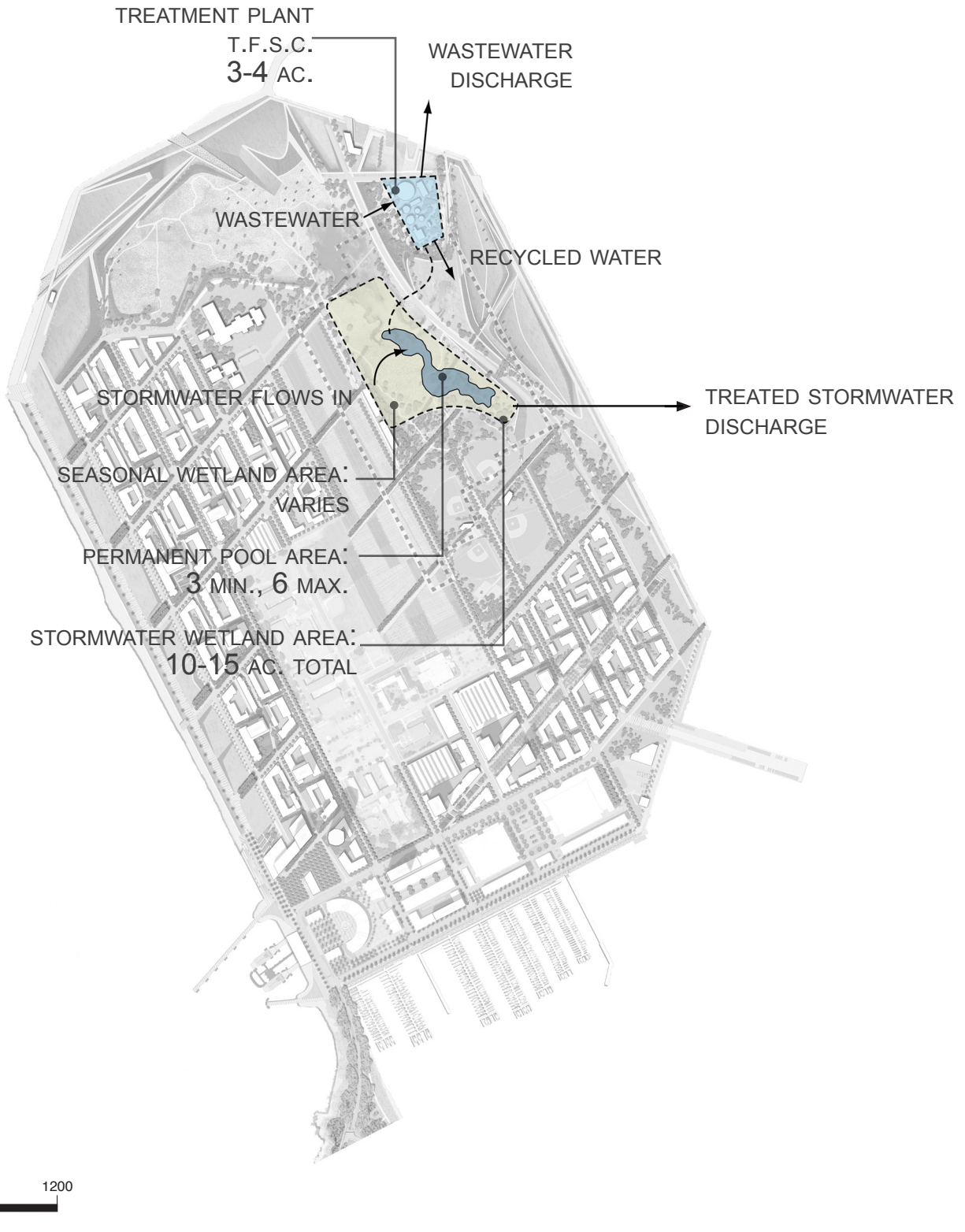

SOURCE: CMG

Treatment Wetland. A 10- to 15-acre treatment wetland would be located in the northeast corner of Treasure Island. The wetland area would serve as both a stormwater treatment area during the rainy months and as a wildlife habitat area for Treasure Island year round. Figure IV.K.5 shows the location and conceptual design of the treatment wetland. The final design and size would be based on the treatment requirements for discharge of stormwater set by the RWQCB in compliance with the City's NPDES discharge permit and in accordance with its Stormwater Design Guidelines. The final location and configuration of the wetland would depend on a number of factors, including size relative to contributing watersheds, soil contamination, groundwater,⁷² public access, open space plans, and storm drainage infrastructure design.⁷³

The wetland system would be designed to treat 90 percent of average annual runoff on a volumetric basis (0.75 inches per unit area).⁷⁴ The drawdown time for stormwater to be treated would be a minimum of 48 hours.⁷⁵

Stormwater would enter the wetland system through diversion structures with lift stations. It would first encounter sedimentation forebays that would collect trash and larger sediments. The forebays would also provide a place to clean up dry-season contamination or spills before they enter the rest of the system.⁷⁶ Flow out of the forebays would be controlled by a weir structure.

The flow would proceed through low-flow channels and swales to the permanent pool. The permanent pool would promote both aerobic and anaerobic zones to enhance pollutant removal (e.g., oxidation by microorganisms). The recommended minimum permanent pool size is twice the treatment volume. Based on current estimates, it would be between 3 and 6 acres, with a minimum depth of 5 feet.⁷⁷ The depth would discourage unwanted vegetation growth (such as cattails), but this depth would intersect the groundwater table. Regarding the possibility of contaminated groundwater polluting the stormwater, see Section IV.P, Hazards and Hazardous Materials, p. IV.P.44-IV.P.45.

The perennial wetlands would remain moist or wet throughout the year. Any desired permanent water level during the dry months would be maintained with water from the recycled water system, preliminarily estimated as about 29,000 gallons per day.⁷⁸

⁷² For example, excavation for wetlands and ponds may be limited by the presence of contaminated groundwater at Site 24, known as the Dry Cleaning Facility. See Section IV.P, Hazards and Hazardous Materials for discussion of contamination and its remediation.

⁷³ *Infrastructure Update*, Chapter 10, Addendum #1, May 11, 2009 (“*Infrastructure Update, Chapter 10, Addendum #1*”), p. 1.

⁷⁴ *Memorandum: Treasure Island Stormwater Update*, December 1, 2009, pp. 3-4 (stating that the SFPUC staff has verbally indicated acceptance of the draft MS4 NPDES permit flow-through requirement).

⁷⁵ *Infrastructure Update, Chapter 10, Addendum #1*, p. 2.

⁷⁶ *Ibid*, p. 2.

⁷⁷ *Ibid*, p. 2.

⁷⁸ *Ibid*, p. 2.

Seasonal wetland areas—meadow-like areas that would flood during the rainy season—would be created adjacent to the main, permanent wetland pool to provide additional treatment and habitat area. Water from the main perennial pool would expand into the seasonal areas during and after storm events. Pollutants would be removed through settling, adsorption, filtering, and nutrient uptake by wetland vegetation.

The stormwater wetland system would discharge to the Bay. An outfall or weir would control the discharge. If necessary, a lift station would lift the effluent for discharge.

The wetlands would provide habitat for a range of flora and fauna, including migratory birds. (See Section IV.M, Biological Resources.) Public access would be provided to the stormwater wetland area. In some parts of the wetlands, low fences may be needed to separate people and dogs from the habitat areas and to ensure public safety. Signs would be posted to advise visitors that the water is non-potable. Access to the habitat areas in the wetlands would also be controlled with pathways and planting.

An Integrated Pest Management program for Treasure Island would include vector control for the wetland area. Mosquitofish would be used, and plants that attract mosquitoes would be avoided, while plants that repel mosquitoes would be used. The edges of permanent pool areas of the wetlands would be designed to allow access to mosquito predators. In addition, water levels in the wetland would be varied to discourage mosquito development by occasional drawdown at some times and augmentation with recycled water at other times. Vegetation maintenance would reduce breeding habitat.

Best Management Practices. BMPs would be selected, sized, and designed in relation to localized building sites and land spaces in each of several stormwater watersheds for Treasure Island and Yerba Buena Island. Some BMPs would be structural, like a control device, and others would be non-structural, like a maintenance activity.

Structural BMPs. Structural BMPs are designed based on flow or volume.⁷⁹ In flow-based design, water is treated by flowing through vegetation or filtration media. Examples are bioretention areas, flow-through planters, and vegetated swales. In volume-based design, water is treated by detention and settlement. Examples are extended detention basins and treatment wetlands.

In addition to the stormwater treatment wetland, “localized” stormwater runoff BMP treatment techniques are proposed to provide treatment for stormwater in Stormwater Treatment Areas (as

⁷⁹ *Memorandum: Treasure Island Stormwater Update*, December 1, 2009, p. 3.

shown on Figure IV.K.6: Treasure Island Stormwater Treatment Areas. The treatment techniques could include, but are not limited to:⁸⁰

- Bio-retention. Bio-retention areas are vegetated systems that rely on soil infiltration and biogeochemical processes to slow, store, and remove pollutants from stormwater. Examples are soil- and plant-based filtration devices, including a planted buffer strip, a sand bed, a ponding area, and a planted area with an organic (or mulch) layer and planting soil.
- Constructed wetland. As discussed above, the Proposed Project would include a constructed wetland. Such wetlands collect and purify stormwater through microbial transformation, plant uptake, settling, and adsorption of pollutants.
- Vegetated swale. A vegetated swale is a broad, shallow channel with plants on the sides and bottom to collect and slowly convey rainwater runoff, with treatment provided through filtering by the vegetation and soil or infiltration into the underlying soils.
- Vegetated buffer strip. Vegetated buffer strips are sloping planted areas designed to treat and infiltrate sheet flow from adjacent impervious areas.
- Infiltration basin. An infiltration basin is a shallow impoundment over permeable soil that captures stormwater, stores it, and allows it to infiltrate. These function like bio-retention areas, but are usually larger.
- Infiltration trench. An infiltration trench is a long, narrow, rock-filled trench that allows stormwater to infiltrate.
- Permeable pavement. Permeable pavement is a paving system that includes an underlying layered structure to temporarily store rainwater prior to infiltration or drainage to a collection facility. Examples are porous asphalt, porous concrete, interlocking concrete blocks, or grass pavers.
- Vegetated roofs. Vegetated roofs are covered partially or entirely with vegetation and soils. These filter contaminants. They also absorb stormwater, thereby reducing runoff, and they slow stormwater, thereby delaying the peak flow.
- Rain water harvesting. Rain water harvesting is the practice of collecting rainwater from impervious surfaces, such as roofs or patios, and using it for irrigation. There is uncertainty about legislation regarding the practice, and practical disadvantages regarding storage and timing.

Source Control and Operational BMPs. The Stormwater Control Plan for Treasure Island and Yerba Buena Island would include source control measures that would be used to limit the amount of pollutants entering stormwater runoff. Effective control of pollutants before they enter stormwater would reduce the loading of pollutants on structural BMPs, and would result in a decrease in pollutant load subsequent to structural BMPs. Source control and operational BMPs that would be implemented as part of the Proposed Project in all areas are summarized below.

⁸⁰ *Memorandum: Treasure Island Stormwater Update*, December 1, 2009, pp. 15-16.



KEY

- A STREET RIGHTS OF WAY
- B¹ MIXED USED URBAN CORE AND MARINA DISTRICT
- B² ELEMENTARY SCHOOL SITE
- B³ WASTEWATER TREATMENT FACILITY
- C CITY SOUTH RESIDENTIAL AREA
- D NORTH AND EAST RESIDENTIAL AREAS
- E URBAN AGRICULTURAL PARK, SPORTS PARK AND GENERAL OPEN SPACE AREAS
- F SEASONAL WETLAND AREA

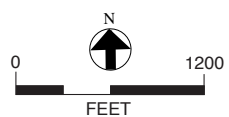

SOURCE: CMG

FIGURE IV.K.6: TREASURE ISLAND STORMWATER TREATMENT AREAS

- Install and maintain trash screens on all storm system inflows, and/or at key points along the stormwater system, to provide effective trash removal;
- Implement a street sweeping program to remove trash, leaves, sediment, and other pollutants from roadways;
- Implement maintenance requirements for landscaping that minimize the use of fertilizers, pesticides, and herbicides;
- Implement an animal waste reduction plan, including requirements for the appropriate disposal of dog wastes; and
- Disconnect catch basins and inlets from paved impervious infrastructure where feasible.

Combinations of structural BMPs are expected to be used in each Stormwater Treatment Area. The options for localized stormwater treatment, along with the stormwater treatment wetland, will be reviewed in detail with SFPUC and the RWQCB. Figure IV.K.6 shows the proposed Treasure Island Stormwater Treatment Areas by letter. The proposed menu of possible BMPs by area is summarized below:⁸¹

- Area A, Public streets: Street-side bio-retention areas.
- Area B1, Mixed use urban core and Marina District: Bio-retention, vegetated swale, vegetated buffer strip, infiltration trench, permeable pavement, vegetated roofs, rainwater harvesting where feasible.
- Area B2, Elementary school site: Bio-retention, constructed wetland, vegetated swale, vegetated buffer strip, infiltration basin, infiltration trench, permeable pavement, vegetated roofs, rainwater harvesting where feasible.
- Area B3, Wastewater treatment plant: Constructed wetland, vegetated swale, vegetated buffer strip, infiltration basin, infiltration trench, permeable pavement, vegetated roofs, rainwater harvesting where feasible.
- Area C, City south residential area: Bio-retention, vegetated swale, rainwater harvesting where feasible.
- Area D, North and east residential areas: Constructed wetland, bio-retention, rainwater harvesting where feasible.
- Area E1, Urban farm, sports park, and general open space areas: Bio-retention, constructed wetland, vegetated swale, vegetated buffer strip, infiltration basin, infiltration trench, permeable pavement, vegetated roofs, rainwater harvesting where feasible.

Proposed Stormwater Treatment System - Yerba Buena Island

Stormwater controls on Yerba Buena Island would include erosion control measures, given the steep topography of much of that island. The BMPs would be based on the SFPUC's *Stormwater Design Guidelines*, and could include bioretention/infiltration planters and swales, rain gardens, and permeable paving, and rainwater harvesting where feasible.

⁸¹ *Memorandum: Treasure Island Stormwater Update*, December 1, 2009, pp. 7-12.

The proposed menus of possible BMPs for the Development Plan areas of Yerba Buena Island are summarized below:⁸²

- Public streets, roads, and parking areas: Bio-retention, vegetated swale.
- Housing and hotel: Bio-retention, vegetated swale, vegetated buffer strip, permeable pavement, vegetated roofs, rainwater harvesting where feasible.
- Existing historic buildings and site areas: Bio-retention, vegetated swale, vegetated buffer strip, permeable pavement, vegetated roofs, rainwater harvesting where feasible.
- Open space areas: Bio-retention, vegetated swale, vegetated buffer strip, permeable pavement, vegetated roofs, rainwater harvesting where feasible.

Project Impacts

Impact UT-7: Construction activities associated with the Proposed Project's stormwater infrastructure could result in air quality, noise, water quality, transportation, hazardous materials, and biological impacts, as further evaluated under those EIR topics. (See significance determinations in other topics.)

The second significance criterion, identified on p. IV.K.25, indicates that the Proposed Project would have a significant adverse effect if it would require, or result in, the construction of new stormwater collection or treatment facilities, where the construction would cause significant environmental effects. Demolition, land clearing, grading, and other ground-disturbing construction activities would temporarily affect local air quality during each construction phase, causing temporary and intermittent increases in particulate dust and other pollutants. Operation of construction trucks and heavy equipment would create fugitive dust and emit nitrogen oxides, carbon monoxide, sulfur dioxide, reactive organic gases or hydrocarbons, and particulate matter, as a result of diesel fuel combustion. Use of hazardous materials in new construction could result in emissions of toxic air contaminants. Construction activities and heavy equipment would also cause temporary and intermittent increases in noise during each construction phase. Excavation may result in release of volatile contaminants in the ground or groundwater, and excavated soils could contain hazardous materials. Construction activities could pollute run-off from construction areas. Construction trucks and other vehicles could cause transportation impacts on local roads and/or the Bay Bridge. Construction activities could adversely affect biological resources.

Impacts of construction, including stormwater facilities, and applicable mitigation measures are discussed in Section IV.E, Transportation, pp. IV.E.67 – IV.E.71 (Impact TR-1); Section IV.F, Noise, pp. IV.F.14 – IV.F.20 (Impacts NO-1 and NO-2); Section IV.G, Air Quality, pp. IV.G.24-IV.G.38 (Impacts AQ-1 – AQ-4); Section IV.M, Biological Resources, pp. IV.M.41-IV.M.63 (Impacts BI-1 – BI-6); Section IV.O, Hydrology and Water Quality, pp. IV.O.35 – IV.O.41

⁸² *Ibid*, pp. 12-15.

(Impacts HY-1 – HY-7); and Section IV.P, Hazards and Hazardous Materials, pp. IV.P.39 – IV.P.51 (Impacts HZ-1 – HZ-9).

Cumulative Impacts

Impact UT-8: Construction and operation of the Proposed Project would not significantly contribute to cumulative infrastructure deficits or result in the exceedance of stormwater discharge requirements. (No Impact)

The Proposed Project would not cause infrastructure deficits at Treasure Island and Yerba Buena. In addition, RWQCB requirements would be met. The other construction projects proposed for Yerba Buena Island would not substantially change the demand for stormwater collection and treatment. Therefore, there would be no cumulative impacts regarding stormwater collection and treatment facilities.

K.4 WATER SUPPLY AND DISTRIBUTION SYSTEM (POTABLE AND FIRE-FIGHTING)

SETTING

Regional Water System

Water for the Project Area is provided by the SFPUC, which manages a complex Regional Water System that provides water to approximately 2.5 million people in San Francisco, including Treasure Island and Yerba Buena Island, and in Santa Clara, San Mateo, Alameda, and Tuolumne Counties. The Regional Water System consists of three integrated water supply and conveyance systems: the Hetch Hetchy, Alameda, and Peninsula systems. The SFPUC is currently implementing the Water System Improvement Program (“WSIP”) to provide improvements to its water infrastructure.

Sources of Water Supply

The sources of the City’s water supply consist primarily of surface water sources. Other, supplemental sources, such as water recycling and desalination, are being developed, and water efficiency measures will allow the existing water supply to serve an increased number of users.

The Regional Water System delivers an annual average of approximately 265 mgd to its customers.⁸³ Approximately 85 percent of that water supply is provided by the Hetch Hetchy system, which diverts water from the Tuolumne River. The balance (approximately 15 percent)

⁸³ San Francisco Public Utilities Commission, *Final Water Supply Assessment for the Proposed Treasure Island – Yerba Buena Island Project*, prepared by PBS&J, November 2009 (hereinafter referred to as “WSA”), p. 2-3. A copy of the WSA is found in Appendix I in this EIR.

comes from runoff in the Alameda Creek watershed, which is stored in the Calaveras and San Antonio Reservoirs, and runoff from the San Francisco Peninsula, which is stored in the Crystal Springs, San Andreas, and Pilarcitos Reservoirs. A small portion of demand, primarily in San Francisco, is met with locally produced groundwater used for irrigation at local parks and on highway medians, and with recycled water, which is used for wastewater treatment process water, sewer box flushing, and similar wash-down operations.

Groundwater

San Francisco overlies all or part of seven groundwater basins: the Lobos, Marina, Downtown, and South basins, located wholly within the City limits, and the Islais Valley, Westside, and Visitacion Valley basins which extend south into San Mateo County. Except for the Westside and Lobos basins, all of the groundwater basins are generally inadequate to supply a significant supply of groundwater for municipal supply due to low yield.

The SFPUC is currently studying implementation of the San Francisco Groundwater Supply Project, created as part of the Water System Improvement Program to expand use of the local groundwater source to provide ongoing supply and to improve reliability during droughts, maintenance conditions, and after an earthquake or other emergency.

Recycled Water

For 50 years prior to 1981, San Francisco's McQueen Treatment Plant provided recycled water to Golden Gate Park for irrigation. Because of changes in water quality regulations, the City closed the McQueen plant and discontinued use of recycled water in Golden Gate Park. Currently, disinfected secondary-treated⁸⁴ recycled water from the SFPUC's Southeast Water Pollution Control Plant is used on a limited basis for wash-down operations in the combined sewer system and is also provided to construction contractors for dust control and other construction purposes. Current use of recycled water for these purposes in San Francisco is less than 1 mgd.⁸⁵

In March 2006, the SFPUC updated the *Recycled Water Master Plan* for the City. The 2006 *Recycled Water Master Plan* identified where and how San Francisco could most feasibly develop recycled water in the City and provided strategies for implementing the recycled water projects that were identified. The SFPUC plans to continue to diversify San Francisco's water supply portfolio by increasing the use of local water sources, such as recycled water, groundwater, water conservation, and desalination.

⁸⁴ Effluent from the plant has undergone both primary and secondary treatment, meaning that floatable materials (such as oil and grease), settleable materials (such as sand and gravel) and a substantial portion of the organic compounds in the waste stream have been removed. In San Francisco, chlorine is used to kill bacteria, and the chlorine is removed before the effluent is used as recycled water.

⁸⁵ WSA, p. 2-5

The San Francisco Recycled Water Program currently includes the Westside, Harding Park, and Eastside Recycled Water Projects. These proposed projects would provide up to 4 mgd of recycled water to a variety of users in San Francisco. Recycled water would primarily be used for landscape irrigation, toilet flushing, and industrial purposes. Currently, the SFPUC is conducting a recycled water demand assessment on the east side of San Francisco. The Water System Improvement Program contains funding for planning, design, and environmental review of the San Francisco Eastside Recycled Water Project.

Desalination

The SFPUC's consideration of desalination as a water supply source has focused primarily on the potential for regional facilities. The proposed Bay Area Regional Desalination Project is a joint venture between the SFPUC, Contra Costa Water District, East Bay Municipal Utility District ("EBMUD"), and the Santa Clara Valley Water District. The regional desalination project would provide an additional source of water during emergencies, provide a supplemental source during extended droughts, allow other major water facilities to be taken out of service for maintenance or repairs without disrupting service, and increase supply reliability by providing water supply from a regional facility. The Bay Area Regional Desalination Project would have an ultimate total capacity of up to 65 mgd.⁸⁶

Water Conservation

The SFPUC is committed to demand-side management⁸⁷ programs and the City's per capita water use has dropped by about one-third since 1977 due, in part, to these programs.⁸⁸ The first substantial decrease occurred following the 1976-77 drought. Gross per capita water use dropped from 160 gallons to 130 gallons per capita per day. Despite continuous growth in the City since then, water demands have remained lower than pre-drought levels. In addition to plans for repairs and improvements to the water supply system infrastructure, the Water System Improvement Program calls for increased water conservation. The SFPUC's current demand management programs range from financial incentives for plumbing devices to improvements in the distribution efficiency of the system. The conservation programs implemented by the SFPUC are based on the California Urban Water Conservation Council's list of 14 BMPs:

- BMP 1 – Water Survey Programs for Single- and Multi-Family Residential Customers
- BMP 2 – Residential Plumbing Retrofit
- BMP 3 – System Water Audits, Leak Detection and Repair
- BMP 4 – Metering with Commodity Rates for all New Connections
- BMP 5 – Large Landscape Conservation Programs and Incentives

⁸⁶ WSA, p. 3-5.

⁸⁷ Demand-side management involves programs that discourage water use and encourage conservation, with the objective of reducing overall water demand.

⁸⁸ WSA, p. 2-5.

- BMP 6 – High Efficiency Washing Machine Rebate (under investigation)
- BMP 7 – Public Information Programs
- BMP 8 – School Education Program
- BMP 9 – Conservation Programs for Commercial, Industrial, and Institutional Accounts
- BMP 10 – Wholesale Agency Assistance Programs
- BMP 11 – Conservation Pricing
- BMP 12 – Conservation Coordinator
- BMP 13 – Water Waste Prohibition
- BMP 14 – Residential Ultra Low Flow Toilet Replacement Program

With this conservation program, the SFPUC anticipates reducing gross per-household consumption from 91.5 gallons per capita per day in 2009 to 87.4 gallons per capita per day by 2018, which would result in a conservation supply potential of approximately 4.0 mgd annually.

Water Supply Reliability Planning

To enhance the reliability of the Regional Water System, improve dry-year supplies, diversify the water supply portfolio, and meet projected wholesale and retail demand through 2030, the SFPUC developed the Water System Improvement Program (“the program” in this subsection) in 2005. Under this program as originally developed, the SFPUC proposed to meet projected 2030 average daily purchase requests of 300 mgd in the Regional Water System service area by increasing diversions from the Tuolumne River under its existing water rights and developing new local resources through a combination of additional conservation, water recycling, and groundwater supply programs. The program proposed various water facility improvement projects to achieve stated public health, seismic safety, delivery reliability and water supply goals. It also included provisions for obtaining additional dry-year supplies. The Program Environmental Impact Report (PEIR) for the Water System Improvement Program identified and analyzed potential impacts that would result from implementation, including the diversion of an additional 35 mgd annual average from the Tuolumne River, along with several water supply combinations that could meet future demand. After certification of the Final PEIR by the Planning Commission on October 30, 2008, the SFPUC adopted the Phased Water System Improvement Program option.

The Phased Water System Improvement Program would meet projected 2018 demand of approximately 285 mgd by capping deliveries from the Regional Water System at 265 mgd, with 184 mgd allocated to wholesale customers and 81 mgd allocated to retail customers.⁸⁹ The remaining 20 mgd of demand would be met through water conservation, recycling and groundwater, with 10 mgd provided by wholesale customers and 10 mgd provided by local projects within San Francisco. Improved dry-year supplies would be provided via implementation of the Westside Groundwater Basin Conjunctive Use Project (in San Mateo County), and less than 2 mgd in water transfers. The 10 mgd of local supply committed to by the

⁸⁹ WSA, p. 2-6.

SFPUC upon adoption of the Phased Water System Improvement Program would be provided through development of local water supply improvements.

Water Treatment Capacity

Water from the Hetch Hetchy system is delivered to customers without filtration. Water from the Alameda system is treated at the Sunol Valley Water Treatment Plant (“Sunol Valley WTP”), located in Alameda County. Peninsula system water and any Hetch Hetchy or Alameda system water stored in Peninsula reservoirs is treated at the Harry Tracy WTP, located in northern San Mateo County. These treatment plants have existing treatment capacities of 160 mgd and 120 mgd, respectively. To ensure treatment capacity into the future, the SFPUC is planning to upgrade the Sunol Valley WTP to reliably treat 160 mgd and increase the plant’s storage capacity of treated water. The SFPUC is also currently designing an expansion of the Harry Tracy WTP to reliably deliver 160 mgd, which would increase the total treatment capacity of the Regional Water System to 320 mgd. These projects would further the delivery reliability goals identified by the SFPUC as part of the Phased Water System Improvement Program by allowing the SFPUC to deliver water to meet demands during maintenance of the Hetch Hetchy system and in the event of an emergency resulting in the temporary loss of the Hetch Hetchy system supply. In addition, SFPUC has initiated construction of the Tesla advanced disinfection treatment facility in Tracy, California, to provide advanced disinfection of water from the Hetch Hetchy system.

Water Shortage and Dry-Year Planning

To ensure that water could be delivered continuously throughout a drought, the SFPUC has adopted a drought planning sequence and associated operating procedures that trigger different levels of water delivery reductions relative to the volume of water stored in SFPUC reservoirs. Each year, during the snowmelt period, the SFPUC evaluates the amount of total water storage expected to occur throughout the Regional Water System. If this evaluation finds the projected total water storage to be less than a level sufficient to provide sustained deliveries, the SFPUC may impose delivery reductions or rationing. The amount of reduction has been established in contractual agreements between the SFPUC and its customers in the Water Shortage Allocation Plan. The SFPUC has adopted the Retail Water Shortage Allocation Plan to formalize the three-stage program of action to be taken in San Francisco. During a shortage of between 5 to 10 percent (Stage 1), SFPUC retail customers would experience no reduction in deliveries, but the SFPUC would issue a voluntary rationing request to customers, alert customers to water supply conditions, remind them of existing water use prohibitions, and provide education on, and possible acceleration of, incentive programs. For a shortage of between 10 to 20 percent (Stage 2), retail customers would experience a 1.9 percent reduction in retail deliveries. During Stage 2, all Stage 1 measures would be implemented, customers would receive a specific allotment of water, and if a customer’s water use goes above their allotment, they would be subject to an

excess use flow restrictor device and shut-off of water. For shortages in excess of 20 percent (Stage 3), all Stage 2 measures and additional reductions in retail allotments would be implemented, as determined by the SFPUC.

Current and Future Water Supplies

As discussed above on p. IV.K.41, the Phased Water System Improvement Program allocates 81 mgd to retail customers. In addition, approximately 3.5 mgd of groundwater is currently obtained from local groundwater basins. Per the Phased Water System Improvement Program, an additional 10 mgd would be provided in the future from local groundwater and recycled water projects and from conservation measures that reduce demand. Table IV.K.1: SFPUC Estimated Retail Water Supplies, 2010–2030 with Normal Rainfall, provides an estimate of retail water supplies from 2010 through 2030. As shown in the table, water supply is projected to increase from 84.5 mgd in 2010 to 94.5 mgd in 2015 (at completion of the Water System Improvement Program projects) and to remain at that level through 2030. As described above, the program includes development of dry-year supplies for the Regional Water System. These supplies would be readily available during dry years when the watershed supplies are cut back due to below-normal precipitation. The PEIR also included an analysis of dry-year water supply transfers from the senior water rights holders (Modesto Irrigation District and Turlock Irrigation District) on the Tuolumne River in 2018; a groundwater conjunctive use project; and a regional desalination project. The SFPUC is currently investigating the possibility of a dry-year transfer with Modesto Irrigation District and Turlock Irrigation District in 2018.

Current and Future Water Demand

The SFPUC prepared and adopted an *Urban Water Management Plan (UWMP)* in 2005 as required by state law.⁹⁰ Since that time, development projects have been proposed that were not contemplated when the 2005 UWMP was adopted. To update the water supply and demand estimates provided in the 2005 UWMP, the SFPUC conducted a *Water Supply Availability Study*.⁹¹ The study incorporates new water supply information (from the Phased Water System Improvement Program) and generates new estimates of future water demand for San Francisco. The future water demand estimates are based on the most current population and employment estimates, which include the Proposed Project and other major development proposals not anticipated in the 2005 UWMP. To update future water demand, the *Water Supply Availability Study* compared the estimates of residential households and employees used in the 2005 UWMP with new population and employment forecasts provided by the San Francisco Planning Department. These forecasts were designed to closely match the recently adopted

⁹⁰ California Water Code Section 10610.4.

⁹¹ WSA, p. 4-2 and WSA Appendix D.

Table IV.K.1: SFPUC Estimated Retail¹ Water Supplies, 2010–2030 with Normal Rainfall

Water Supply Sources	2010	2015	2020	2025	2030
Current Surface Water Supply Sources					
SFPUC RWS (Surface water: Tuolumne River, Alameda & Peninsula)	81.0	81.0	81.0	81.0	81.0
Current Groundwater Sources					
Groundwater (In-City Irrigation Purposes)	2.5	0.5	0.5	0.5	0.5
Groundwater - Other Retail Users	1.0	1.0	1.0	1.0	1.0
Groundwater: Treated for Potable—Previously used for In-City Irrigation purposes	0.0	2.0	2.0	2.0	2.0
<i>Groundwater Subtotal</i>	<i>3.5</i>	<i>3.5</i>	<i>3.5</i>	<i>3.5</i>	<i>3.5</i>
<i>Current Water Supply Subtotal</i>	<i>84.5</i>	<i>84.5</i>	<i>84.5</i>	<i>84.5</i>	<i>84.5</i>
Future Water Supply Sources					
Groundwater Development: Potable from SF GWSP (Westside Groundwater Basin) ^f	0.0	2.0	2.0	2.0	2.0
Recycled Water Expansion for Irrigation	0.0	4.0	4.0	4.0	4.0
Conservation Supply Program	0.0	4.0	4.0	4.0	4.0
<i>WSIP Supply Subtotal</i>	<i>0.0</i>	<i>10.0</i>	<i>10.0</i>	<i>10.0</i>	<i>10.0</i>
<i>Total Retail Supply (Current and WSIP Supplies)</i>	<i>84.5</i>	<i>94.5</i>	<i>94.5</i>	<i>94.5</i>	<i>94.5</i>
<i>Note:</i> ¹ SFPUC's retail customers are homes and businesses, mostly in San Francisco, served directly by the SFPUC. Retail customers also include Treasure Island and customers outside the City at the San Francisco Airport, the Town of Sunol, Lawrence Livermore Laboratories, Castlewood, and Groveland Community Services District.					

Source: PBS&J, *Final Water Supply Assessment for the Proposed Treasure Island – Yerba Buena Island Project*, November 2009, Table 2-3, p. 2-9.

Association of Bay Area Governments *Projections 2009* target, and take into account local knowledge of projects currently in various stages of the entitlement process. Updated water demand estimates were then generated, which included the increment of future growth that was not previously included in the 2005 UWMP estimates.

Estimates of water demand for major development proposals⁹² in San Francisco were based on information provided by project proponents. The water demand estimates were included in the WSA prepared for the Proposed Project.

⁹² Treasure Island – Yerba Buena Island Area Plan/SUD, Parkmerced Project, and Candlestick Point-Hunters Point Shipyard Phase II Project.

IV. Environmental Setting and Impacts
K. Utilities and Service Systems

Table IV.K.2: SFPUC Estimated Average Annual Retail Water Demand, provides an estimate of total SFPUC retail⁹³ water demands from 2010 through 2030, which incorporates the most recent new residential development estimates from 2015 through 2030, and assumes some development not previously included in the 2005 UWMP estimates, including the proposed Candlestick Point-Hunters Point Shipyard project, the proposed Parkmerced project, and other incremental growth throughout San Francisco.⁹⁴ Total retail water demand, including Project Area demand, is estimated to increase from 91.81 mgd in 2010 to approximately 93.42 mgd by 2030.

Table IV.K.2: SFPUC Estimated Average Annual Retail¹ Water Demand

Users, Facilities, and Entities	Projected Water Demand (mgd)				
	2010	2015	2020	2025	2030
San Francisco Residential Demand (Single and Multiple Family)	44.70	43.80	43.20	42.90	42.90
New San Francisco Residential Demand (Generated by Projects and Incremental Growth)	—	0.47	0.95	1.42	1.89
<i>Subtotal</i>	<i>44.70</i>	<i>44.27</i>	<i>44.15</i>	<i>44.32</i>	<i>44.79</i>
Non-Residential - Business/Industrial San Francisco	30.21	30.52	30.83	31.14	31.73
<i>Subtotal</i>	<i>74.91</i>	<i>74.79</i>	<i>74.97</i>	<i>75.46</i>	<i>76.52</i>
Unaccounted-for System Losses	7.30	7.30	7.30	7.30	7.30
<i>Subtotal</i>	<i>82.21</i>	<i>82.09</i>	<i>82.27</i>	<i>82.76</i>	<i>83.82</i>
Other Retail Demands	4.90	4.90	4.90	4.90	4.90
Lawrence Livermore Laboratory; Groveland Community Services District	1.20	1.20	1.20	1.20	1.20
City Irrigation	2.5	2.5	2.5	2.5	2.5
Castlewood Community	1.0	1.0	1.0	1.0	1.0
<i>Total Retail Demand</i>	<i>91.81</i>	<i>91.69</i>	<i>91.87</i>	<i>92.36</i>	<i>93.42</i>

Notes:

¹ SFPUC's retail customers are homes and businesses, mostly in San Francisco, served directly by the SFPUC. Retail customers also include Treasure Island and customers outside the City at the San Francisco Airport, the Town of Sunol, Lawrence Livermore Laboratories, Castlewood, and Groveland Community Services District.

mgd – million gallons per day

Numbers are rounded according to standard rounding practices and may not add up due to hidden decimals.

Source: PBS&J, *Final Water Supply Assessment for the Proposed Treasure Island – Yerba Buena Island Project*, November 2009, Table 4-8. p. 4-9.

⁹³ SFPUC's retail customers are homes and businesses, mostly in San Francisco, served directly by the SFPUC. Retail customers also include Treasure Island and customers outside the City at the San Francisco Airport, the Town of Sunol, Lawrence Livermore Laboratories, Castlewood, and Groveland Community Services District.

⁹⁴ WSA Appendix A, Section 5.1, pp. 21-22.

Water Conveyance and Distribution System

Water is distributed within San Francisco by the SFPUC's distribution system. The City's internal distribution system is divided into the Eastside (roughly from Twin Peaks to the Bay) and the Westside (roughly from Twin Peaks to the ocean). San Francisco's water supply is delivered to the City in several major pipelines and stored in reservoirs located within the City. Water is delivered to the Eastside of the distribution system by the Crystal Springs pipeline and stored in the University Mound Reservoir. Several smaller reservoirs, in addition to storage tanks and pumps, provide water to individual distribution zones based on elevation.

Treasure Island and Yerba Buena Island have two sources of water. The primary supply is provided by the SFPUC's water distribution system in San Francisco. An emergency supply is provided by EBMUD.

Water from the SFPUC system is delivered to Treasure Island / Yerba Buena Island through a 10-inch-diameter steel pipe attached to the west span of the Bay Bridge. Water is pumped across the bridge by a pumping station located on Spear Street in San Francisco. The station contains four pumps, each rated at 900 gallons per minute ("gpm"). The station can run a maximum of two pumps at a time for a maximum output of 1,800 gpm. The SFPUC chloraminates this water prior to transmission; additional treatment on Treasure Island is not required. A standby booster station is available for emergencies where the pipeline touches down on Yerba Buena Island. The SFPUC provides water for the Job Corps campus and the Coast Guard Station and Sector Facility.

The emergency water supply is provided by EBMUD through a 12-inch-diameter, ductile iron, main pipeline connected to an EBMUD water meter at Beach Street in Oakland. From the water meter, the 12-inch main is owned and maintained by the Navy. The main delivers water to a pump station located below the eastern end of the existing Bay Bridge in Oakland. Water is then pumped through a 12-inch-diameter steel pipe attached to the east span of the Bay Bridge. This water supply charges the fire hydrants on the Bridge and is connected to the existing water tanks on Yerba Buena Island for an emergency supply. The maximum flow rate for this system is 1,500 gpm. There is currently an agreement between EBMUD and the Navy regarding flow rates that maintain water quality in the line on the Bridge. Actual annual average flow is about 35 gpm. The water is chloraminated by EBMUD before delivery. The new east span of the Bay Bridge includes a replacement pipeline that will be connected to the EBMUD supply when the existing bridge is taken out of service and the new span is opened.

As described above, SFPUC furnishes potable water to existing water tanks on Yerba Buena Island. There are currently four concrete reservoirs with a total design capacity of approximately

IV. Environmental Setting and Impacts
K. Utilities and Service Systems

6.5 million gallons that serve as both the potable and fire protection water supplies for Treasure Island / Yerba Buena Island. The tanks range in age from 60 to 85 years. Although the design capacity is approximately 6.5 million gallons, the tanks are in varying states of disrepair and cannot operate to their full design capacity. The actual, existing operating storage

capacity is approximately 1.9 million gallons, with another 0.5 million gallons dedicated for reserve fire protection. The existing operating storage would be used during the initial phases of the Proposed Project, but would eventually be replaced with new tanks.

The tanks are connected to water users on Treasure Island and Yerba Buena Island through distribution piping. Water flows by gravity to Treasure Island and by gravity and pumping to Yerba Buena Island. The distribution piping constructed in 1939 consisted of separate systems for potable water and fire protection. In 1990, the two systems were combined and segments of the original copper, galvanized steel, and asbestos cement pipes were replaced with PVC pipe. Many of the original building services and irrigation services have not been replaced. The relatively new PVC water distribution system would be used on an interim basis during the initial phases of construction, but would eventually be replaced by full buildout of the Proposed Project.

Regulatory Framework

The following state and local laws, programs, and policies affect the supply and use of water in San Francisco. No federal laws apply.

State

Urban Water Management Plan

In 1983, the California Legislature enacted the Urban Water Management Planning Act (California Water Code §§10610 - 10656). The Act states that every urban water supplier that provides water to 3,000 or more customers, or that provides over 3,000 acre-feet of water annually, should make every effort to ensure the appropriate level of reliability in its water service sufficient to meet the needs of its various categories of customers during normal, dry, and multiple dry years. The Act describes the contents of the UWMP as well as how urban water suppliers should adopt and implement the plans. The plan must be updated at least every five years on or before December 31 in years ending in five and zero. In 2005, San Francisco prepared an Urban Water Management Plan as required by the California Water Code.

Water Supply Assessment

The State of California adopted Senate Bill 610 (“SB 610”) effective January 1, 2002. SB 610 requires land use planning entities, such as the City and County of San Francisco, when evaluating large development and redevelopment projects,⁹⁵ to request an assessment of the availability of water supplies from the water supply entity that will provide water to a project. The Water Supply Assessment (“WSA”) is performed in conjunction with the land use approval process associated with a project and must include an evaluation of the sufficiency of the water supplies available to the water supplier to meet existing and future demands, including the demand for a project over a 20-year time period that includes normal, single-dry, and multiple-dry years.

When a new development project is accounted for in the demand projections of an UWMP, the WSA can refer to the UWMP and no further analysis is necessary. In an effort to streamline the water supply planning process within San Francisco, the SFPUC adopted a resolution in 2006 to allow for all development projects requiring a WSA under SB 610 to rely solely on the SFPUC’s adopted UWMP without having to prepare individual WSAs. Because the Planning Department and SFPUC are currently engaged in planning for various large land development proposals that go beyond the future developments considered in the UWMP, the SFPUC concluded that its UWMP no longer accounted for every qualifying project in San Francisco. Therefore, until the UWMP is updated in 2010, a WSA must be prepared for any qualifying project not accounted in the adopted UWMP, including the Proposed Project. The WSA must consider the SFPUC’s current and projected supplies in light of projected demands associated with new growth not covered in the UWMP.

A WSA has been prepared for the Treasure Island / Yerba Buena Island Redevelopment Project and is presented in Appendix I of this EIR.

Water Supply Verification

California Government Code Section 66473.7 requires that a condition be included in any tentative subdivision map (or development agreement) for a residential subdivision of 500 or more units mandating that a “sufficient water supply” be available to serve the subdivision in addition to existing and planned future water uses.⁹⁶ The appropriate public water system must submit to the city or county a water supply verification evaluating whether such a sufficient water

⁹⁵ Under SB 610, large projects are defined as: 1) a project creating the equivalent demand of 500 residential units, 2) a proposed shopping center or business establishment employing more than 1,000 persons or having more than 500,000 square feet of floor space, 3) a commercial building employing more than 1,000 persons or having more than 250,000 square feet of floor space, 4) a proposed hotel of more than 500 rooms, or 5) a mixed-use project with one or more projects of these sizes. (In addition, there are other triggers under the Act related to industrial uses.)

⁹⁶ Added to the California Water Code under Senate Bill 220, 2001.

supply exists, based on substantial evidence. If verification of a sufficient water supply cannot be provided, a final subdivision map cannot be issued for the subdivision, and the subdivision cannot be built.

Local

Water Conservation

San Francisco's Residential Water Conservation Ordinance generally requires a homeowner to install water conservation equipment (such as low-flow showerheads, faucets, and toilets) prior to selling a home or making a major improvement to the home.⁹⁷

Water Recycling for Irrigation and Other Uses

In 1991, the SFPUC sponsored and the San Francisco Board of Supervisors passed a Reclaimed Water Use Ordinance⁹⁸ generally requiring development projects over 40,000 sq. ft. to build and operate a reclaimed water system within the buildings and a reclaimed water irrigation system for the landscaping.⁹⁹

San Francisco General Plan

The San Francisco General Plan Environmental Protection Element includes the following objectives and policies that are relevant to the proposed Area Plan.

- Objective 5: Assure a permanent and adequate supply of fresh water to meet the present and future needs of San Francisco.
 - Policy 1: Maintain an adequate water distribution system within San Francisco.
 - Policy 2: Exercise controls of development to correspond to the capabilities of the water supply and distribution system.
 - Policy 3: Ensure water purity.
 - Policy 5: Improve and extend the Auxiliary Water Supply System of the Fire Department for more effective fire fighting.
- Objective 6: Conserve and protect the fresh water resource.
 - Policy 1: Maintain a leak detection program to prevent the waste of fresh water.
 - Policy 2: Encourage and promote research on the necessity and feasibility of water reclamation.

⁹⁷ San Francisco Department of Building Inspection, "What You Should Know about San Francisco's Residential Energy and Water Conservation Requirements,"

<http://www.sfdbi.org/Modules/ShowDocument.aspx?documentid=124>, accessed June 17, 2010.

⁹⁸ San Francisco Public Works Code, Article 22, <http://library.municode.com/HTML/14142/level1/A22.html>, accessed June 15, 2010.

⁹⁹ *Ibid*, section 1204.

IMPACTS

Significance Criteria

The City and County of San Francisco has not formally adopted significance standards for impacts related to utilities. The Planning Department's Initial Study Checklist provides a framework of topics to be considered in evaluating potential impacts under CEQA. Implementation of a project could have potentially significant impact related to water if it were to:

- Require or result in the construction of new water or wastewater treatment facilities or expansion of existing facilities, the construction of which could cause significant environmental effects.
- Have sufficient water supply available to serve the project from existing entitlements and resources, or require new or expanded water supply resources or entitlements.

Approach to Analysis

Typically, EIRs compare the water demand of the project to the capacity of the existing water delivery infrastructure and water supply. In this case, water would be provided to the Proposed Project by the SFPUC from its existing Regional Water System, and no new or expanded water treatment facilities would be necessary to meet the water demand of the Proposed Project, for the reasons set below. For the Proposed Project, water demand is based on the Water Supply Assessment prepared for the Proposed Project by the SFPUC.

Proposed Water Distribution and Supply Facilities

Potable Water

The existing SFPUC pump station in San Francisco and the existing 10-inch diameter pipeline on the west span of the Bay Bridge would continue to be the primary means of supplying water to the Project Area. An emergency water supply to Treasure Island / Yerba Buena Island would be provided by a new 12-inch-diameter pipeline on the new east span of the Bay Bridge, connected to a new SFPUC pump station near the eastern base of the Bridge. The new system would be capable of delivering up to 1,800 gpm of potable water from the EBMUD connection point on Beach Street in Oakland. The water would be chloraminated by EBMUD prior to delivery, as with the existing emergency supply.

- The water source from EBMUD provides an emergency water source¹⁰⁰ to the Project Area. If the SFPUC system were to be taken off-line for maintenance, power interruptions, or damage due to an earthquake, EBMUD would be capable of supplying 1,800 gpm, sufficient to meet peak demands for the Proposed Development Project on an emergency basis. In the extremely unlikely event that both water supplies would be unavailable at the same time, then 2 days of maximum daily demand plus 4 hours of fire storage available in the proposed replacement water tanks is expected to be sufficient to provide necessary water supply during the time required for repairs or evacuation of the Islands. In an extreme emergency, the consumption of potable water would likely be much less than the calculated average daily demand.
- Utility service to the Job Corps campus and buildings would be maintained throughout the phased buildout of the Proposed Project. Water service to the Job Corps campus would be more robust under the Proposed Project. Certain modifications for connections of the water pipes would be necessary at the perimeter of the Job Corps site. Details would be worked out during the design process for each major phase. Recycled water would be available to the Job Corps campus.
- Water service to the Coast Guard Station and Sector Facility would be maintained throughout the buildout of the Proposed Project. Certain modifications to the piping for connections of the water pipes would be necessary. Details would be worked out during the design process. TIDA and the Coast Guard have agreed that they would enter into a Memorandum of Understanding (MOU). The MOU would include (among other things) a process for the Coast Guard to notify TIDA when it is considering modernization projects, so that modifications for increased utility demand can be coordinated. Among other things, the MOU would also address construction coordination to ensure uninterrupted utility delivery and service.

Based on population projections, commercial and institutional use projections, and fire protection requirements, the total volume of water storage needed for the Project Area would be 4.0 million gallons. In order to provide this amount of storage, two new storage tanks would be constructed on Yerba Buena Island:

- A 1.0-million-gallon tank at the location of the existing tank adjacent to Macalla Road, and
- The remainder of the storage would occur in a single 3.0-million-gallon tank, divided into two 1.5-million-gallon cells, either adjacent to the 1.0-million-gallon tank or on the west slope of YBI adjacent to the proposed hotel.

● ¹⁰⁰ EBMUD currently provides 220 mgd of water to approximately 1.3 million people as well as industrial, commercial, and institutional customers in its 331-square-mile service area. EBMUD is not the water supply purveyor for the Proposed Project.

IV. Environmental Setting and Impacts
K. Utilities and Service Systems

The existing 2.4 million gallons of operating storage would continue to be used during the initial phases of the Proposed Project. The storage tanks would be supplied by water pumped directly from the 10-inch supply line from San Francisco, or from the back-up supply from EBMUD during emergencies.

The Development Program would completely replace the existing PVC water distribution system in phases with ductile iron pipe that would conform to SFPUC requirements.

Firefighting Water Supply

Treasure Island and Yerba Buena Island do not currently have a supplemental firefighting water supply system for fire protection. The Proposed Project includes construction of a new firefighting water supply system on Treasure Island and a supplemental fire protection system in the event of an extended total disruption of both sources of potable water supply to the island. The supplemental system is not planned to serve Yerba Buena Island due to its steep topography, smaller development size, and proximity to the water storage tanks. The supplemental firefighting water system would have two sources of supply: recycled water and Bay water.

The recycled water portion of the system would include storage for one average day of recycled water demand of 420,000 gallons for Treasure Island, and 840,000 gallons of recycled water for the supplemental firefighting supply, for a total of 1.26 million gallons of recycled water storage. Storage would be provided on Treasure Island in the vicinity of the recycled water plant. The system would have pumping facilities capable of providing combined fire and recycled water demands. The pumping facility would have back-up power and redundant pumps for reliability. The system would include fire hydrants independent of the domestic water supply fire hydrants; these hydrants would be identified as non-potable water.

A separate Bay water supplemental system would also be provided, with two fire boat manifolds and two suction hydrants located along the southern shore of Treasure Island near the existing hangar buildings. The manifolds would allow the fireboats to connect to the supplemental Bay water supply system in an extreme emergency and charge the lines in the event the recycled water system were to fail.¹⁰¹ Two suction hydrants that would allow fire trucks to draw water directly from San Francisco Bay.

Construction of portions of the supplemental firefighting water supply system would require temporary shoreline excavation and backfill that could create water quality impacts in the Bay. Water quality impacts are discussed in Section IV.O, Hydrology and Water Quality.

Operation and testing of the intake facilities of the supplemental system could cause marine safety hazards and biological impacts. Operation of the intake structures has the potential to cause a vortex at the end of the intake pipeline, which could create a hazard at the water surface. To prevent this, the mouth of the intake pipe would be enlarged to reduce the flow velocity at the mouth of the pipe or otherwise designed to prevent vortex formation. Biological impacts are discussed in Section IV.M, Biological Resources.

¹⁰¹ When connected to the pipe manifold, the fireboat would draw salt-water via its on-board pump. This is inherent to the operation of the fireboat and happens wherever and whenever the existing fireboats currently operate.

Recycled Water

As described in Section IV.K.2, Wastewater Recycling Plant, Storage, and Distribution, under “Proposed Project Facilities,” p. IV.K.14, the Proposed Project would recycle wastewater for irrigation, and approved commercial and residential uses, including toilet flushing and other authorized plumbing fixtures. Because the recycled water would offset the demand for potable water, use of recycled water is further discussed below.

The Proposed Project would create approximately 216 acres of open space area on Treasure Island, including the urban farm and roadside planter areas, and approximately 25 acres of open space to be planted in turf grass for recreational use as part of the Sports Park. These areas would require permanent, long-term irrigation. The remainder of the open space would be planted with native and adapted drought-tolerant vegetation species that would require irrigation to become established, but would need substantially less, or no, irrigation after becoming established. The largest irrigation demand would occur during the dry season, April to October, with peak demands expected in July. In addition, the storm water treatment wetlands would also require makeup water during the dry season. Recycled water demand for irrigation would increase with the phased construction of the open space, peaking with the completion of the North Shoreline Park and The Wilds areas on the north end of Treasure Island in the last phase of construction. Demand would be reduced as the natural areas are established and removed from the irrigation system. In contrast, the recycled water demand in commercial and residential buildings would grow as such buildings are constructed and occupied, and then would be relatively constant throughout the year.

If recycled water demand during the first phases of development exceeds the recycled water supply, excess demand would be met with the potable water system. Because the potable water storage would be constructed at the beginning of the Proposed Project, there would be sufficient potable water available to supplement the recycled water supply in early phases when domestic demand has not reached build-out levels. During the period of development when the potable water supply is needed to supplement the recycled water supply, the potable water system would be temporarily connected to the recycled water system. This temporary connection would include a backflow prevention device approved by the SFPUC. The connection would be removed once the recycled supply is sufficient to meet demand.

The Proposed Project assumes that recycled water would be used in residential buildings for toilet flushing and any other authorized uses to the extent permitted by applicable State and local laws and regulations at the time of construction. It is assumed that residential buildings would provide currently-required piping to allow such applicable future use(s), and the estimates for recycled water production outlined above would generate sufficient recycled water to support recycled water uses as currently authorized. The Water Supply Assessment for the Proposed Project

analyzed the Proposed Project without use of recycled water in order to provide a conservative estimate of water demand. Recycled water would be a new water source and would reduce demand from the City's water system.

The use of gray water (water from sinks, showers, and similar sources, captured for local reuse) in residential buildings is not currently allowed. If changes are made in applicable State and local laws and regulations, individual residential buildings may construct the necessary capture facilities and piping systems for gray water. Any use of gray water would conform to all applicable state and local requirements. Because it is not known where or whether these water sources would be used, they are not evaluated further in this EIR.

Recycled Water Supply

As described in more detail in "Wastewater Recycling Plant and Distribution," p. IV.K.14, recycled water would be provided by an on-island recycled water plant that would provide the forecasted, average, long-term, recycled water demand of approximately 0.42 mgd. The recycled water plant would be constructed adjacent to the wastewater treatment plant on Treasure Island and would include 1.26 million gallons of storage (0.42 million gallons to meet average day irrigation and non-potable building demands and 0.84 million gallons for fire flow). The recycled water plant would treat secondary wastewater effluent from the wastewater treatment plant.

- Wastewater effluent would be treated with microfiltration, reverse osmosis (to the extent required), and disinfection to meet California standards for recycled water. The recycled water treatment facility would be constructed and operated by the SFPUC; storage tank(s) or other facilities would be constructed by the project sponsors and/or the SFPUC. The recycled water treatment plant would be constructed in phases concurrent with the wastewater treatment plant.

Distribution piping for recycled water would be provided on Treasure Island in phases; recycled water would not be used on Yerba Buena Island in view of its distance from the recycled treatment plant and the pumping that would be required by the elevation change in order to supply a very limited local demand.

Project Impacts

Water Infrastructure Construction

Impact UT-9: Construction activities associated with water infrastructure of the Proposed Project could result in air quality, noise, water quality, transportation, hazardous materials, and biological impacts, as further evaluated under those EIR topics. (See significance determinations in other topics.)

All of the water infrastructure on the Islands would be new and installed as part of the Proposed Project. This construction activity would involve relatively shallow trenches.

As described previously, water for the Proposed Project would be provided by the SFPUC from its existing water treatment system and no new water treatment facilities would be required for the Proposed Project.

While the WSA finds that there would be sufficient water supply in the SFPUC regional system to serve the Proposed Project, construction of recycled water treatment facilities is included as part of the Proposed Project. As noted in the WSA, this would be an additional supply and is not needed to meet water demands from the Proposed Project.¹⁰²

Demolition, land clearing, grading, and other ground-disturbing construction activities associated with the installation of the new water infrastructure would temporarily affect local air quality during each construction phase, causing temporary and intermittent increases in particulate dust and other pollutants. Operation of construction trucks and heavy equipment would create fugitive dust and emit nitrogen oxides, carbon monoxide, sulfur dioxide, reactive organic gases or hydrocarbons, and particulate matter, as a result of diesel fuel combustion. Use of hazardous materials in new construction could result in emissions of toxic air contaminants. Construction activities and heavy equipment would also cause temporary and intermittent increases in noise during each construction phase. Excavation may result in release of volatile contaminants in the ground or groundwater, and excavated soils could contain hazardous materials. Construction activities could pollute run-off from construction areas. Construction trucks and other vehicles could cause transportation impacts on local roads and/or the Bay Bridge. Construction activities could adversely affect biological resource.

Impacts of construction of the water distribution facilities and any related mitigation measures are discussed in Section IV.E, Transportation, pp. IV.E.67 – IV.E.71 (Impact TR-1); Section IV.F, Noise, pp. IV.F.14 – IV.F.20 (Impacts NO-1 and NO-2); Section IV.G, Air Quality, pp. IV.G24-IV.G.38 (Impacts AQ-1 – AQ-4); Section IV.M, Biological Resources, pp. IV.M.41-IV.M.63 (Impacts BI-1 – BI-6); Section IV.O, Hydrology and Water Quality, pp. IV.O.35 – IV.O.41 (Impacts HY-1 – HY-7); and Section IV.P, Hazards and Hazardous Materials, pp. IV.P.39 – IV.P.51 (Impacts HZ-1 – HZ-9).

Water Supply

Impact UT-10: There would be sufficient water supply available to serve the Proposed Project from existing entitlements and resources, and no new or expanded water supply resources or entitlements would be needed. (No Impact)

Project Water Demand

The WSA estimates that the water demand of the Proposed Project at full buildout in 2030 would be about 1.63 mgd. Table IV.K.3: Estimated Water Demand for Treasure Island and Yerba

¹⁰² WSA, pp. 1-6 and 4-5.

Buena Island (2030) presents the Proposed Project water demand at buildout, plus continuing demand associated with the other two users on the Islands, the Department of Labor and U.S. Coast Guard. The data in Table IV.K.3 assume compliance with the plumbing requirements of the California Building Code and with San Francisco’s Green Building Ordinance.¹⁰³

Table IV.K.3: Estimated Water Demand for Treasure Island and Yerba Buena Island (2030)

Land Use and Facilities	Estimated Water Demand (gpd)
Residential	962,000
Small Community Facilities	1,418
Pier 1 Community Center	3,675
Open Space	210,000
<i>Subtotal Residential</i>	<i>1,177,093</i>
Hotel	136,000
Office	10,500
Retail	14,700
Adaptive Reuse, General	25,620
Adaptive Reuse, Retail	7,035
Miscellaneous Structures	7,500
Marina	20,000
Treasure Island School	21,000
Police/Fire	6,000
Treasure Island Sailing Center	1,575
Museum	7,875
Department of Labor	111,542
Coast Guard Facility	17,000
Utility Facilities	1,470
Urban Farm	62,000
<i>Subtotal Non-Residential</i>	<i>449,817</i>
TOTAL	1,626,910

Source: PBS&J, *Final Water Supply Assessment for the Proposed Treasure Island – Yerba Buena Island Project*, November, 2009, Table 4-2, p. 4-3.

Water Supply / Water Demand

To assess the adequacy of current and projected future water supplies to meet estimated future demand, including the demand associated with the three major development proposals including implementation of the Proposed Project and other projected future growth (e.g., background growth from Association of Bay Area Government’s projections), the WSA included a comparison of retail water supply and demand. Table IV.K.4: Comparison of Projected Water Supply and Demand for Normal, Single Dry, and Multiple Dry Years, provides a comparison of the projected future retail water supply and demand in varying drought conditions over the WSA’s 20-year planning horizon through 2030.

¹⁰³ The Proposed Project would either comply with the San Francisco Green Building Ordinance or with a set of equivalent or superior requirements adopted by TIDA as part of the Proposed Project’s Green Building specifications.

The deficit shown in 2010 is the result of the Phased Water System Improvement Program, which restricts the SFPUC's allocation from the Regional Water System supply to 81 mgd. Full development of the additional 10 mgd of new local supplies from groundwater, recycled water, and conservation programs, is projected to be available by 2015. However, current retail demand is much lower than the estimated 2010 demand in Table IV.K.2, p. IV.K.45 (actual Fiscal Year 2007-2008 demand was 83.9 mgd). If retail demand exceeds the available Regional Water System supply of 81 mgd between 2010 and 2015, and total Regional Water System deliveries exceed 265 mgd between 2010 and 2015, the Water Supply Agreement that is part of the Phased Water System Improvement Program (see "Water Supply Reliability Planning," above on p. IV.K.41) allows the SFPUC to purchase additional water from the Regional Water System for retail customers in the SFPUC service area by paying an environmental surcharge.^{104,105} It is expected, therefore, that the Proposed Project would not contribute to any deficiencies in supply experienced by the SFPUC between 2010 and 2015. After 2015, when the additional 10-mgd local supply is projected to be completed, the WSA shows no expected deficit in supply during normal years.

As shown in Table IV.K.4, by 2030, during the second and third year of a multiple dry-year period, the projected water supply would be slightly less than the estimated total retail demand, including demand associated with the Proposed Project. Thus, during multiple dry-year periods, the SFPUC would need to implement the provisions of the Water Shortage Allocation Plan and the Retail Water Shortage Allocation Plan, which could include voluntary rationing or the curtailment of retail deliveries. With the implementation of the Water Shortage Allocation Plan and the Retail Water Shortage Allocation Plan during multiple dry-year periods, existing and projected future water supplies would be sufficient to meet estimated future water demand.

The deficit shown in 2010 in Table IV.K.4 is the result of reducing the regional water system supply to 81 mgd as per the Phased WSIP Variant, without full development of the additional 10 mgd of new supplies. 10 mgd of new sources would be developed and available for use in San Francisco by 2015. However, San Francisco retail demand is currently lower than projected. (Fiscal Year 2007-2008 use was 83.9 mgd.) If San Francisco retail demands exceed the available supply of 84.5 mgd between 2010 and 2015, the Water Supply Agreement allows the SFPUC to purchase additional water from the regional water system. If combined retail and wholesale deliveries exceed 265 mgd, the SFPUC retail customers would be required to pay an Environmental Surcharge for deliveries over 81 mgd. (Total regional water system deliveries in FY07/08 were 256.7 mgd.)

¹⁰⁴ Total Regional Water System deliveries in FY07/08 were 256.7 mgd, which is 8.3 mgd below the 165 mgd watershed delivery goal.

¹⁰⁵ WSA, p. 5-1.

Table IV.K.4: Comparison of Projected Water Supply and Demand for Normal, Single Dry, and Multiple Dry Years (mgd)

Retail Supply and Demand		Normal Year	Single Dry Year	Multiple Dry Year Event		
				Year 1	Year 2	Year 3
2010	RWS Supply	81.00	81.00	81.00	79.50	79.50
	Groundwater Supply	3.50	3.50	3.50	3.50	3.50
	Total Retail Supply	84.50	84.50	84.50	83.00	83.00
	Total Retail Demand	91.81	91.81	91.81	91.81	91.81
	<i>Surplus/(Deficit)^a</i>	<i>(7.31)</i>	<i>(7.31)</i>	<i>(7.31)</i>	<i>(8.81)</i>	<i>(8.81)</i>
2015	RWS Supply	81.00	81.00	81.00	79.50	79.50
	Groundwater	3.50	3.50	3.50	3.50	3.50
	WSIP Supply Sources	10.00	10.00	10.00	10.00	10.00
	Total City Supply	94.50	94.50	94.50	93.00	93.00
	Total Retail Demand	91.69	91.69	91.69	91.69	91.69
<i>Surplus/(Deficit)</i>	<i>2.81</i>	<i>2.81</i>	<i>2.81</i>	<i>1.31</i>	<i>1.31</i>	
2020	RWS Supply	81.00	81.00	81.00	79.50	79.50
	Groundwater	3.50	3.50	3.50	3.50	3.50
	WSIP Supply Sources	10.00	10.00	10.00	10.00	10.00
	Total City Supply	94.50	94.50	94.50	93.00	93.00
	Total Retail Demand	91.87	91.87	91.87	91.87	91.87
<i>Surplus/(Deficit)</i>	<i>2.63</i>	<i>2.63</i>	<i>2.63</i>	<i>1.13</i>	<i>1.13</i>	
2025	RWS Supply	81.00	81.00	81.00	79.50	79.50
	Groundwater	3.50	3.50	3.50	3.50	3.50
	WSIP Supply Sources	10.00	10.00	10.00	10.00	10.00
	Total City Supply	94.50	94.50	94.50	93.00	93.00
	Total Retail Demand	92.36	92.36	92.36	92.36	92.36
<i>Surplus/(Deficit)</i>	<i>2.14</i>	<i>2.14</i>	<i>2.14</i>	<i>0.64</i>	<i>0.64</i>	
2030	RWS Supply	81.00	81.00	81.00	79.50	79.50
	Groundwater	3.50	3.50	3.50	3.50	3.50
	WSIP Supply Sources	10.00	10.00	10.00	10.00	10.00
	Total City Supply	94.50	94.50	94.50	93.00	93.00
	Total Retail Demand	93.42	93.42	93.42	93.42	93.42
<i>Surplus/(Deficit)</i>	<i>1.08</i>	<i>1.08</i>	<i>1.08</i>	<i>(0.42)^b</i>	<i>(0.42)^b</i>	

Notes:

mgd – million gallons per day

RWS – Regional Water System

WSIP – Water System Improvement Plan

^a The deficit shown in 2010 is the result of reducing the RWS supply to 81 mgd as per the Phased WSIP Variant, without full development of the additional 10 mgd of new supplies. 10 mgd of new sources would be developed and available for use in SF by 2015. However, SF retail demand is currently lower than projected (FY07/08 use was 83.9 mgd). If SF retail demands exceed the available supply of 84.5 mgd between 2010 and 2015, the Water Supply Agreement allows the SFPUC to purchase additional water from the RWS. If combined retail and wholesale deliveries exceed 265 mgd, the SFPUC retail customers would be required to pay an Environmental Surcharge for deliveries over 81 mgd (Total RWS deliveries in FY07/08 were 256.7 mgd).

^b Deficit occurs in year 2 and 3 of multiple dry year event, SFPUC implements its Drought Year Water Shortage Contingency Plans - RWSAP and WSAP would be required to balance supply and demand under this projected shortfall.

Source: PBS&J, *Final Water Supply Assessment for the Proposed Treasure Island – Yerba Buena Island Project*, November, 2009, Table 5-1.

The Proposed Project's total water demand of 1.63 mgd would account for approximately 1.7 percent of the total Regional Water System retail demand in 2030. The Proposed Project's demand would not affect the ability of the SFPUC to serve its retail customers.¹⁰⁶

The WSA did not assume that recycled water would be available; therefore, recycled water is considered an additional water supply source beyond the SFPUC's Water System Improvement Program recycled water supplies. Thus, the WSA provided a conservative water supply analysis, and projected potable water use for the Project Area and the Coast Guard at 1.63 mgd. (See Table IV.K.3: Estimated Water Demand for Treasure Island and Yerba Buena Island (2030), p. IV.K.56.) However, recycling water is part of the Proposed Project. The wastewater treatment plant to be constructed by the SFPUC as part of the Proposed Project would include facilities to recycle wastewater. The Project Area is designated as a recycled water use area as defined in San Francisco's Recycled Water Ordinances. The ordinances require property owners to install dual plumbing systems for recycled water use for certain uses within the designated use areas. In compliance with the City's Recycled Water Ordinances and to support the goals of the Sustainability Plan for the Project Area, the Sustainability Plan includes a program to use recycled water on Treasure Island. As described above in Section IV.K.2., Wastewater Recycling Plant, Storage, and Distribution, under "Proposed Project Facilities," p. IV.K.17, recycled water would be used for irrigation of the open space areas, the urban farm, roadside planter areas, landscape water features, and toilet flushing in buildings. These measures would reduce the overall potable water demand of the Proposed Project. This would reduce the amount of potable water required by about 0.30 mgd.

As the WSA concludes, implementation of the Proposed Project would not require an expansion of the SFPUC's water supply facilities or infrastructure to increase delivery capacity, nor would it adversely affect the City's water supply. The population growth accommodated by the Proposed Project would be within the projections used as the basis for demand estimates in the *Water Supply Availability Study*. In addition, the SFPUC has adopted a long-term water management plan and is undertaking a number of efforts to meet projected system-wide demand and ensure the reliability of the system's water supply. As described above, the SFPUC has sufficient water supply and delivery capacity to provide service to the Project Area. For that reason, implementation of the Proposed Project would have a less-than-significant impact on water supply.

¹⁰⁶ WSA, p. 6-1.

Cumulative Impacts

Impact UT-11: Implementation of the Proposed Project would not result in a cumulatively considerable impact on existing entitlements and resources, and no new or expanded water supply resources or entitlements would be needed. (*No Impact*)

The *Water Supply Assessment* analyzes the Proposed Project's water demand in the context of overall future water demand from all of the SFPUC's customers. Therefore, it provides an assessment of future cumulative impacts on water supplies. Based on the discussion above summarizing the conclusions of the WSA that sufficient water would be available to serve all SFPUC demand, there would not be a significant cumulative impact on water supply. Therefore, the Proposed Project's contribution to long-term water demand would not result in a significant cumulative impact.

K.5 SOLID WASTE DISPOSAL

SETTING

Recology provides solid waste collection, recycling, and disposal services for residential and commercial garbage and recycling at Treasure Island / Yerba Buena Island. San Francisco uses a three-cart collection program: residents and businesses sort solid waste into recyclables, compostable items, such as food scraps and yard trimmings, and garbage.

All materials are taken to the San Francisco Solid Waste Transfer and Recycling Center, located on Tunnel Avenue in the southeast corner of San Francisco. There, the three waste streams are sorted and bundled for transport to the composting and recycling facilities and the landfill.

San Francisco has created the first large-scale urban program for collection of compostable materials in the country. Residents and restaurants and other businesses send food scraps and other compostable material to Recology's Jepson-Prairie composting facility, located in Solano County. Food scraps, plant trimmings, soiled paper, and other compostables are turned into a nutrient-rich soil amendment, or compost.

Recyclable materials are sent to Recycle Central, located at Pier 96 on San Francisco's Southern waterfront, where they are separated into commodities and sold to manufacturers that turn the materials into new products.

Garbage is taken to the Altamont Landfill located east of Livermore in Alameda County. The Altamont Landfill is a regional landfill that handles residential and construction waste. The Altamont Landfill has a permitted maximum disposal of 11,500 tons per day and received about

1.29 million tons of waste in 2007 (the most recent year reported by the State).¹⁰⁷ In 2007, the waste contributed by San Francisco (approximately 628,914 tons) represented approximately 49 percent of the total volume of waste received at this facility.¹⁰⁸ The remaining permitted capacity of the landfill is about 45.7 million cubic yards.¹⁰⁹ With this capacity, the landfill can operate until 2032;¹¹⁰ however, the landfill's permit to operate will expire in 2029.

In 1988, the City of San Francisco contracted for the disposal of 15 million tons of solid waste at Altamont. Through August 1, 2009, the City has used approximately 12.5 million tons of this contract capacity. The City projects that the remaining contract capacity will be reached no sooner than August 2014.

On September 10, 2009, the City and County of San Francisco announced that it intends to award its landfill disposal contract to SF Recycling & Disposal Inc., a subsidiary of Recology. SF Recycling & Disposal says it would ship solid waste from San Francisco by rail to its Recology Ostrom Road landfill in Yuba County.¹¹¹ The landfill is open to commercial waste haulers and can accept up to 3,000 tons of municipal solid waste per day. The site has an expected closure date of 2066 with a total design capacity of over 41 million cubic yards.¹¹² The Board of Supervisors is expected to ratify a new agreement by the end of 2010. The agreement will be for 5 million tons of capacity, which could represent 20 or more years of use

Hazardous waste, including household hazardous waste, is handled separately from other solid waste. Recology operates a facility at the San Francisco Dump for people to safely dispose of the hazardous waste generated from their homes. The most common wastes received are leftover paint, motor oil from cars, thinners, spray cans, and old garden products, such as pesticides and fertilizers. Commercial hazardous material collection and disposal is discussed in Section IV.P, Hazards and Hazardous Materials, p. IV.P.52.

¹⁰⁷ California Department of Resources Recycling and Recovery (CalRecycle), "Active Landfills Profile for Altamont Landfill & Resource Recovery (01-AA-0009)", <http://www.calrecycle.ca.gov/Profiles/Facility/Landfill/LFProfile2.asp?COID=1&FACID=01-AA-0009>, accessed April 18, 2010.

¹⁰⁸ For Altamont Landfill Disposal Tonnage – California Department of Resources Recycling and Recovery (CalRecycle), "Active Landfills Profile for Altamont Landfill & Resource Recovery (01-AA-0009)", at <http://www.calrecycle.ca.gov/Profiles/Facility/Landfill/LFProfile2.asp?COID=1&FACID=01-AA-0009>, and City and County of San Francisco 2007 Diversion/Disposal Rate Report at <http://www.calrecycle.ca.gov/LGCentral/Tools/MARS/JurDrDtl.asp?Flag=1&Ju=438&YR=2007>, accessed April 26, 2010.

¹⁰⁹ *Ibid.*

¹¹⁰ California Department of Resources Recycling and Recovery (CalRecycle), "Facility/Site Summary Details: Altamont Landfill & Resource Recovery (01-AA-0009)", <http://www.calrecycle.ca.gov/SWFacilities/Directory/01-AA-0009/Detail/>, accessed April 18, 2010.

¹¹¹ *Waste Age*, "San Francisco Plans to Award Landfill Contract to Recology Subsidiary," <http://wasteage.com/news/san-francisco-landfill-contract-recology-20090911/>, accessed April 18, 2010.

¹¹² Recology web site, <http://www.recologyostromroad.com/>, accessed April 18, 2010.

Under the California Integrated Waste Management Act of 1989, San Francisco was required to adopt an integrated waste management plan, implement a program to reduce the amount of waste disposed, and have its waste diversion performance periodically reviewed by the California Integrated Waste Management Board. The City was required to reduce the amount of waste sent to landfill by 50 percent by 2000. The City met the 50 percent reduction goal in 2000 by recycling, composting, reuse, and other efforts, and achieved 70 percent reduction in 2006.

In 2007, the State altered its evaluation criteria for assessing a jurisdiction's programmatic effectiveness in reducing solid waste with the passage of the Solid Waste Disposal Measurement Act in Senate Bill 1016 ("SB 1016"). As a result, the complex and lengthy (generally 18 to 24 months) diversion rate measurement system has been replaced by a more simplified system that sets a 50 percent Equivalent Per Capita Disposal Target (resident or employee) for the State and each jurisdiction. This target rate is updated using the Department of Finance's yearly population estimates and employment data from the Employment Development Department. In 2008, the target disposal rate for San Francisco residents and employees was 6.6 pounds/resident/day and 10.6 pounds/employee/day. Both of these targeted disposal rates were met, for 2008, with San Francisco residents generating about 3.7 pounds/resident/day and employed persons in San Francisco generating about 5.5 pounds/per employee/per day.

Regulatory Framework

California Integrated Waste Management Act – Assembly Bill 939

The 1989 California Integrated Waste Management Act ("CIWMA") mandated that source reduction be the highest priority waste management strategy, followed by recycling and composting and environmentally safe transformation and land disposal. The law required that each county prepare an Integrated Waste Management Plan. The Act also required that each city prepare a source reduction and recycling element, with a plan for reducing solid waste by 25 percent by 1995 and 50 percent by 2000 using a 1989 baseline). Later revisions required that local jurisdictions and state agencies also achieve 50 percent reduction in solid waste by 2000.

Solid Waste Disposal Measurement Act – Senate Bill 1016

SB 1016 maintains the 50 percent diversion requirement set forth under the CIWMA, but changes the measurement system to a disposal based system – expressed as the 50 percent Equivalent Per Capita Disposal Target. This per capita disposal target is the amount of disposal a jurisdiction would have had during the base period if it had been exactly at a 50 percent diversion rate. The 50 percent Equivalent Per Capita Disposal Target is calculated by dividing the average of 2003-2006 per capita generation in half. Each jurisdiction has a specific 50 percent Equivalent Per Capita Disposal Target that cannot be compared to other jurisdictions. This disposal target is an indicator or baseline that is used to compare against the annual per capita disposal rate. This

change shifts the focus away from numeric estimates, which are just one indicator to consider, and toward diversion program implementation efforts that are better and more meaningful long-term indicators. The shift in focus from estimated diversion to measured disposal allows jurisdictions to track their programmatic progress more effectively because of the turnaround time for State review of disposal rate summaries – within 6 to 9 months rather than the 18 to 24 months under the former system. In addition, for jurisdictions that already meet the 50 percent diversion rate, such as San Francisco, annual waste generation studies are no longer required, allowing more resources to be focused on the development or maintenance of waste reduction strategies.

City of San Francisco

The City of San Francisco has enacted several programs to divert solid waste from the landfill. The Construction and Demolition Debris Recovery Ordinance, adopted in 2006, requires preparation of a waste diversion plan and diversion of 65 percent or more of the construction and demolition debris from disposal in a landfill. The City's Green Building Ordinance, which became effective January 1, 2009, requires that at least 75 percent of a project's construction debris be diverted from the landfill.¹¹³ In June 2009, the Board of Supervisors passed the Mandatory Recycling & Composting Ordinance, which requires all of San Francisco to separate recyclables, compostables, and landfilled trash. The City's Plastic Bag Reduction Ordinance requires the use of compostable plastic, recyclable paper and/or reusable checkout bags by supermarkets and drugstores. The Food Service Waste Reduction Ordinance requires restaurants and food vendors to use food ware that is made of compostable or recyclable material rather than styrofoam. The Resource Conservation Ordinance requires City departments to reduce waste, maximize recycling, and buy products with recycled content. The Mayor's Executive Order on Bottled Water prohibits City departments from using public funds to purchase bottled water. In 2002, the Board of Supervisors set goals of achieving 75 percent diversion by 2010 and zero solid waste by 2020.¹¹⁴

The Community Facilities Element¹¹⁵ of the *San Francisco General Plan* contains the following policy relating to solid waste:

Objective 11: Locate solid waste facilities in a manner that will enhance the effective and efficient treatment of solid waste.

Policy 11.1: Provide facilities for treatment of solid waste and locate such facilities as shown on the Wastewater and Solid Waste Facilities Plan.¹¹⁶

¹¹³ The Proposed Project would adopt Green Building Specifications that meet or exceed these requirements.

¹¹⁴ San Francisco Department of the Environment, Website: http://www.sfenvironment.org/our_programs/program_info.html?ssi=3, accessed April 18, 2010.

¹¹⁵ The Community Facilities Element of the *San Francisco General Plan* is available at http://www.sf-planning.org/ftp/general_plan/I7_Community_Facilities.htm (accessed April 26, 2010).

IMPACTS

Significance Criteria

The City and County of San Francisco has not formally adopted significance thresholds for impacts related to solid waste. The Planning Department Initial Study Checklist form provides a framework of topics to be considered in evaluating potential impacts under CEQA.

Implementation of a project could have a potentially significant impact related to solid waste if it were to:

- Be served by a landfill with insufficient permitted capacity to accommodate the project's solid waste disposal needs; or
- Fail to comply with Federal, State, and local statutes and regulations related to solid waste.

Approach to Analysis

The Proposed Project would generate solid waste during construction and during operation as proposed new buildings are occupied with residents and business employees, and as recreation facilities are used by residents and visitors. The analysis calculates the estimated amount of solid waste expected to be generated and compares these amounts to estimates of existing solid waste volumes and to landfill capacities. City requirements for recycling, composting, and reuse of solid waste materials are discussed in relation to the Proposed Project's solid waste generation.

The project sponsors are also considering an automated, mechanical system to collect solid waste from new buildings on Treasure Island. See Section VI.E., Automated Waste Collection System Variant for analysis of this variant.

Project Impacts

Impact UT-12: The Proposed Project would be served by a landfill with sufficient capacity to accommodate the Proposed Project's solid waste disposal needs. (*Less than significant*)

Construction Impacts

Construction in the Development Plan Area would generate solid waste by the demolition and deconstruction¹¹⁷ of existing structures and infrastructure. Construction and buildout of the

¹¹⁶ The Wastewater and Solid Waste Facilities Plan noted here in Policy 11.1 is a map that covers only mainland San Francisco. It does not include Treasure Island and Yerba Buena Island; therefore, the map provides no direction related to the Development Plan Area.

¹¹⁷ Deconstruction means removing the building in such a way that reusable and recyclable materials are conserved.

proposed Development Program would be phased and would be anticipated to occur over an approximate 10- to 20-year period.

The buildings to be demolished or deconstructed are primarily of wood and concrete construction and were formerly used for housing, administration, storage, classrooms, shops, dormitories, and a variety of other purposes. To the extent practical, existing structures would be deconstructed, allowing for maximum reuse of materials. The feasibility of reuse or recycling of materials may be limited by requirements for abatement of hazardous materials such as lead-based paint and asbestos, and by the potential value of the recycled material. In addition to the demolition and deconstruction of structures, all existing pavements, underground utilities, and overhead utilities would be removed. Where possible, concrete and asphalt pavements would be recycled or used on site or made available for use elsewhere; a concrete/asphalt crushing plant would be operated on Treasure Island to assist in recycling/reuse of these materials. The crushing plant would be a long-term temporary facility, located for efficiency during the various demolition and construction phases. Impacts related to the crushing plant are discussed in Section IV.G, Air Quality, pp. IV.G.27 (Impact AQ-2) and Section IV.F, Noise, pp. IV.F.14 – IV.F.17 (Impact NO-1). Metals in utilities would be recycled as feasible.

Trees and other vegetation would be protected in place, relocated, or removed as needed from areas to be graded. All trees and plants to be removed would be recycled by composting for on-site use during future planting and erosion control activities.

The City's Construction and Demolition Debris Recovery Ordinance, adopted in 2006, would require preparation of a waste diversion plan and the Green Building Ordinance, which became effective January 1, 2009, would require that at least 75 percent of the project's construction debris is diverted from the landfill.¹¹⁸ To comply with these requirements, and assist in achieving the sustainability goals for the project, the Development Program would include a Master Deconstruction and Demolition Plan. Deconstruction would allow reuse or recycling of the wood, concrete, metals and other materials.

The construction of new residential, commercial, and institutional space and infrastructure would incorporate recycled materials where feasible. Sustainability goals of the Proposed Project include obtaining 20 percent of the building materials locally, and obtaining 10 percent of the building materials using recycled content. These goals would apply to both structures and pavement materials.

¹¹⁸ The Proposed Project would comply with these requirements either through compliance with the two ordinances themselves, or by incorporating equivalent or superior requirements into the Proposed Project's Green Building Specifications, which would be adopted by TIDA.

Operational Impacts

According to CalRecycle, formerly the California Integrated Waste Management Board, San Francisco residents generate approximately 3.7 pounds of solid waste per resident per day, while commercial uses generate approximately 5.5 pounds per employee per day.¹¹⁹ In 2008, the City produced a total of approximately 594,732 tons of solid waste.¹²⁰ At the current population and employment level, Treasure Island / Yerba Buena Island generates approximately 1,550 tons of solid waste per year.¹²¹ At project buildout, the Project Area would generate approximately 15,520 tons of solid waste per year.¹²² This would be slightly less than approximately 2.5 percent of the total quantity of solid waste generated in 2008 by the City as a whole.

The City has implemented a number of aggressive strategies to divert additional solid waste and achieve Citywide diversion goals. The City plans to achieve a 75 percent landfill diversion by 2010 and full (100 percent) waste diversion by 2020. The City encourages residents and businesses to pre-sort recyclables, compostable wastes (food scraps and yard waste), and garbage into separate curbside collection containers; sponsors regular public outreach events to educate San Francisco residents and businesses about waste diversion techniques; and conducts special collection events for wastes that are not generally recyclable at curbside (e.g. batteries, electronics, hazardous wastes). For municipal operations, City departments participate in a sustainable purchasing program that encourages the purchase of recyclable materials. The City also sponsors grants for waste diversion research and works with businesses to create market opportunities for materials reuse and recapture. Local waste management providers have upgraded sorting and transfer facilities to maximize the volume of material diverted. On June 9, 2009, the Board of Supervisors approved an ordinance that requires recycling and composting by residential and commercial uses. All residents and businesses of the Development Plan Area would be required to comply with the City's mandatory recycling and composting ordinance. The project sponsors would also provide recycling facilities for residents and tenants of commercial and retail space, including recycling containers in common areas.

The City's contribution to landfills is anticipated to diminish over time as the City implements more aggressive waste-diversion strategies. Increasing solid waste diversions would extend the life of the landfill used by the City, lengthening the time horizon before the remaining disposal capacity is filled.

¹¹⁹ CalRecycle, Website. Diversion/Disposal Rate Report for City and County of San Francisco, 2008. Accessed at <http://www.calrecycle.ca.gov/LGCentral/Tools/MARS/JurDrDtl.asp?Flag=1&Ju=438&YR=2008..>

¹²⁰ *Ibid.*

¹²¹ Based on existing (2010) population of 1,820, and employment of 320 persons.

¹²² Based on 2030 population of 18,640, and employment of 2,920.

The increased residential population and commercial activity resulting from the Proposed Project would incrementally increase total waste generation from the City. The increasing Citywide rate of diversion through recycling, composting, and other methods would result in a decreasing amount of the City's total waste that requires deposition in the landfill. The City's contract with the Altamont Landfill expires in 2014. After that date, the City will begin using the Ostrom Road landfill in Yuba County. This landfill has a closure date of 2066 with a total design capacity of over 41 million cubic yards. The City will have a contract for 5 million tons of capacity, which could represent 20 or more years of use beginning in 2014. This would be sufficient to accommodate the solid waste generated from the Development Plan Area until at least 2030 (Proposed Project buildout), if not longer.

Given the City's record of reducing its municipal waste sent to the landfill, and given the near-term capacity available at the Altamont Landfill and the long-term capacity available at the Ostrom Road Landfill, the solid waste from the construction and operation of the Proposed Project would not result in the landfill exceeding its permitted capacity, and would result in a less-than-significant impact, and no mitigation is required.

Impact UT-13: The project would not fail to comply with Federal, State, and local statutes and regulations related to solid waste. (*Less than Significant*)

Under the California Integrated Waste Management Act of 1989, San Francisco was required to adopt an integrated waste management plan, and implement a program to reduce the amount of waste sent to the landfill. The City was also required to reduce the amount of waste sent to landfill by 50 percent by 2000. The City met the 50 percent reduction goal in 2000 by recycling, composting, reuse, and other efforts. The City has continued to reduce its waste stream and achieved a reduction of 70 percent in 2006.

All residents and businesses in the Development Plan Area would be required to comply with the City's mandatory recycling and composting ordinance. The project sponsors would also provide recycling facilities for residents and tenants of commercial and retail space, including placing recycling containers in common areas.

Regarding construction, as discussed above under Impact UT-11, the project sponsors would either comply with the City's Construction and Demolition Debris Recovery Ordinance and Green Building Ordinance or with equivalent or superior provisions in the Proposed Project's Green Building specifications. To comply, and to assist in achieving the sustainability goals for the Proposed Project, the Development Program would include the Master Deconstruction and Demolition Plan, discussed above.

Therefore, the Proposed Project would comply with local solid waste ordinances, would comply with and exceed State standards for reducing solid waste, and would comply with Federal solid waste requirements. No mitigation measures are required.

Cumulative Impacts

Impact UT-14: Construction and operation of the Proposed Project would not result in a cumulatively considerable contribution to regional impacts on landfill capacity. (*Less than Significant*)

The City and County of San Francisco currently exceeds statewide goals for reducing solid waste, and is expected to further reduce solid waste volumes in the future. The operation of the Proposed Project would not contribute considerably to significant regional impacts on landfill capacity, because it would comply with City and County of San Francisco requirements to reduce solid waste as would other development projects that would also contribute waste to the City's landfills. The other construction projects proposed for Yerba Buena Island and other large, proposed development projects in the City would generate construction waste during their construction periods. However, the Proposed Project's program of construction waste diversion would reduce its contribution to overall solid waste volumes such that the contribution would not be considerable, and the project would not have significant cumulative impacts.

K.6 ELECTRICITY, NATURAL GAS, AND TELECOMMUNICATIONS INFRASTRUCTURE

SETTING

Existing Electrical Demand and Supply

The estimated, existing, peak electrical-capacity demand for Treasure Island and Yerba Buena Island is approximately 3.1 megawatts ("MW").¹²³ This figure includes the existing residential and commercial uses, wastewater treatment plant, Job Corps, and Coast Guard.

During the period when Naval Station Treasure Island was an operating base, the Navy was responsible for procuring and transmitting power to NSTI. Since the base was operationally closed in 1997, the SFPUC has provided electricity to Treasure Island and Yerba Buena Island. The SFPUC currently acts as a contractor to TIDA, who, as the master lessee of the property from the Navy, has rights to the Navy-owned power facilities.

¹²³ *Infrastructure Update*, Chapter 11, Addendum, Aug. 18, 2009 ("*Infrastructure Update*, Chapter 11, 8/18/2009 Addendum"), Section 11.1.1. This value is based on recorded meter data for the period November 2004 to October 2005.

The SFPUC generates power at the Hetch Hetchy Water and Power project in and near Yosemite National Park, at other locations in the Sierra Nevada Mountains, and the SFPUC also purchases power. The SFPUC formed an internal group called the Power Enterprise in 2005, dividing its Hetch Hetchy Water and Power staff into two distinct enterprises. The Power Enterprise focuses on providing adequate and reliable supplies of electric power to meet the municipal requirements of the City and County of San Francisco.¹²⁴ The Redevelopment Project group within the Power Enterprise manages short-term utility services and long-term development of infrastructure improvements at Treasure Island and Yerba Buena Island.¹²⁵

The City has three hydroelectric projects, capable of producing 401 MW of electricity during the spring run-off period, when the associated water reservoirs are full.¹²⁶ During an average year, the hydroelectric plants are capable of producing 1.7 million megawatt-hours (“MWh”).¹²⁷ The City also owns approximately 150 miles of high voltage transmission lines that link the hydroelectric facilities with the California grid, including linking at Newark, California, in the East Bay. From the Newark substation, Pacific Gas & Electric Co. (“PG&E”) wheels power to San Francisco over its transmission lines.

The SFPUC also purchases power from PG&E and other generators, including the Western Area Power Authority (“WAPA”). The SFPUC relies on a combination of PG&E, Port of Oakland, and Navy-owned facilities to transmit power to Treasure Island via Oakland.

Existing Electrical System

Distribution to Treasure Island

Electricity to the Islands starts at PG&E’s 115 kilovolt (“kV”) substation (“Station C”) located at Grove Street and Second Street in Oakland. A 115 kV overhead transmission line, owned by the Port of Oakland and Navy, and operated and maintained by PG&E, carries power about 2.1 miles to the Davis Substation located at Seventh Street and Maritime Street in Oakland. The Davis substation is on Port of Oakland property and is owned and operated by the Port. Under an Interconnection Agreement with the SFPUC, approximately one-third of the Davis Substation’s 40 Megavolt-ampere (“MVA”) capacity is dedicated to the Navy and Treasure Island.¹²⁸ Figure II.18: Proposed Dry Utilities System, in Chapter II, Project Description, p. II.68, shows the Davis Substation.

¹²⁴ SFPUC web site, http://sfwater.org/mc_main.cfm/MC_ID/12, accessed April 13, 2010.

¹²⁵ SFPUC web site, http://sfwater.org/mto_main.cfm/MC_ID/12/MSID_ID/138/MTO_ID/241, accessed April 13, 2010.

¹²⁶ SFPUC and San Francisco Dept. of Environment, *The Electricity Resource Plan: Choosing San Francisco’s Energy Future* (Revised Dec. 2002) (“ERP 2002”), pp. 21-22.

¹²⁷ ERP 2002, p. 22.

¹²⁸ *Infrastructure Update*, Chapter 11, 8/18/2009 Addendum, Section 11.1.3.

Electricity from the Davis Substation toward Treasure Island is conveyed through a Navy-owned 12 kV overhead line that runs 2.7 miles to a point near the eastern end (“Lands End”) of the Bay Bridge in Oakland. The line connects to existing 12 kV submarine cables that travel under the Bay to Treasure Island. Figure II.18 show the cables from “Lands End” in Oakland to the southeastern corner of Treasure Island.

Prior to construction of the new east span of the Bay Bridge, there was one submarine cable. As part of construction of the East Span, Caltrans installed two new replacement submarine cables. The two new cables have been tested, and one is currently in operation.¹²⁹ The second cable will be put into operation after payment to Caltrans from SFPUC is completed in 2012. The old cable may still be functional, but has not been tested since the bridge piers were built.

As shown on Figure II.18, power is carried along the southeastern edge of Treasure Island to an electric switchgear within Building 3. Electricity to Treasure Island is distributed through a network of 12-kV underground and overhead lines. Electricity to Yerba Buena Island is conveyed from Building 3 through a submarine cable that runs from Treasure Island to Yerba Buena Island under Clipper Cove.

Distribution on the Islands

The SFPUC maintains and operates the existing electrical distribution system. The submarine cables terminate on Treasure Island near the end of 3rd Street. Distribution begins at a switching station within Building 3. Treasure Island is divided into sections served by a mix of underground cables and overhead lines. The rated capacities of the distribution lines are unknown.

The submarine cable from Treasure Island to Yerba Buena Island terminates at the Yerba Buena Island Main Substation. From here, power is distributed to Yerba Buena Island via a combination of poles and underground facilities. The Coast Guard Station and Sector Facility obtains its electrical power from a tie-in to the power delivered to Yerba Buena Island by this submarine cable.

On-Site Generation – Emergency Back-up Power

There are two, trailer-mounted, diesel-powered generators (2 MW capacity each) on Treasure Island for emergency back-up power.¹³⁰ These are located near Building 3 and connect to the main 12 kV switchgear. In the event of a power outage due to an off-island event, the generators can be manually started. They are tested weekly. Each unit has a double-walled, diesel, storage

¹²⁹ *Ibid.*

¹³⁰ *Infrastructure Update*, Chapter 11, 8/18/2009 Addendum, Section 11.1.5.

tank. Each tank holds about 2,100 gallons of diesel fuel. This is adequate to run each generator at 70 percent load for about 20 hours.¹³¹

Existing Natural Gas Demand

The existing, natural gas demand at Treasure Island/Yerba Buena Island is roughly 1.5 million therms¹³² per year.¹³³ This includes Job Corps and the Coast Guard.

Existing Natural Gas System

- Natural gas on the Islands is provided by the SFPUC through a contract with the State of California Department of General Services (DGS). The contract with DGS provides for the transmission of natural gas through PG&E transmission lines in the East Bay to a submarine pipeline from Oakland to Treasure Island. A 10-inch diameter gas pipeline conveys natural gas to the southeast corner of Treasure Island. During construction of the east span of the Bay Bridge, Caltrans and PG&E replaced a portion of the pipeline, due to conflicts with bridge construction.

The pipeline termination on Treasure Island includes a large meter. Gas distribution lines radiate out from this meter to serve Treasure Island and Yerba Buena Island via the causeway at a pressure of 10 psi. There are no submeters for individual buildings or users of natural gas beyond the terminal point of the PG&E facilities on Treasure Island. The Navy currently owns these lines, but the SFPUC maintains them. Several kinds of pipe, including polyvinyl chloride and steel are used.

There is no existing natural gas back-up supply.¹³⁴

Existing Telecommunications Infrastructure

AT&T provides land-based telephone service, and a variety of other telecommunications companies provide cellular service to the Islands.¹³⁵ Comcast provides cable television service,

¹³¹ *Ibid.*

¹³² A British thermal unit (BTU) is the amount of heat needed to raise the temperature of one pound of water (approximately 8.3 gallons) one degree Fahrenheit. A therm is a unit of measurement for natural gas, equivalent to 100,000 BTU's.

¹³³ *2006 Treasure Island Sustainability Plan*, p. 45. This rough number is from a figure, "Natural Gas Consumption (by Phase)," and was derived from a SFPUC metered data set for 1996-2006, using 2004-2006 data.

¹³⁴ *Infrastructure Update*, Chapter 11, 8/18/2009 Addendum, Section 11.3.

¹³⁵ The Coast Guard may have independent, military facilities in addition.

- and satellite companies may also provide television service. These services are provided via conduits on the west span of the Bay Bridge, and then distributed onto the Islands. The Coast Guard Station and Sector Facility obtains its wired (land-based) telecommunications services from the same connections to the mainland.

Regulatory Framework

Federal and State laws and local policies that govern electric and natural gas supply and demand are explained in Section IV.Q, Mineral and Energy Resources, under “Regulatory Framework” in

“Energy,” pp. IV.Q.5 – IV.Q.9. The regulatory framework regarding electric, natural gas, and telecommunications infrastructure is discussed below.

Federal

Federal pipeline safety regulations apply to natural gas pipelines.¹³⁶ The California Public Utilities Commission (“CPUC”) has augmented these regulations, as discussed below.

State

The CPUC regulates investor-owned utilities operating in California, including Pacific Gas & Electric Company and AT&T. The CPUC issues General Orders governing many aspects of facility and equipment construction by utilities, and a major focus of these General Orders is ensuring public safety. General Order 128 provides rules for construction of underground electric supply and communications systems,¹³⁷ such as in the proposed joint utility trench (see below). General Order 112-E provides rules for construction of natural gas piping systems.¹³⁸ General Order 95 contains rules for overhead electric line construction.¹³⁹

Local

Regarding the Proposed Project and building code enforcement, while the Navy still owns Treasure Island, the San Francisco Department of Building Inspection (“DBI”) advises TIDA regarding building code compliance. Subsequent to the land transfer DBI would perform compliance reviews with respect to various building codes, such as the San Francisco Building Code (which includes the California Building Code) and San Francisco Electrical Code, just as DBI does throughout the City.¹⁴⁰

¹³⁶ 49 Code of Federal Regulations, parts 190, 191, 192, 193, and 199.

¹³⁷ California Public Utilities Commission, General Order No. 128, Rules for Construction of Underground Electric Supply and Communications Systems (Jan. 2006), <http://www.cpuc.ca.gov/PUC/documents/go.htm>, accessed April 13, 2010.

¹³⁸ California Public Utilities Commission, General Order No. 112-E, State of California Rules Governing Design, Construction, Testing, Operation, and Maintenance of Gas Gathering, Transmission, and Distribution Piping Systems (Aug. 2008), <http://www.cpuc.ca.gov/PUC/documents/go.htm>, accessed April 13, 2010.

¹³⁹ California Public Utilities Commission, General Order No. 95, Rules for Overhead Electric Line Construction (June 2009), <http://www.cpuc.ca.gov/PUC/documents/go.htm>, accessed April 13, 2010.

¹⁴⁰ San Francisco Department of Building Inspection, web site, “Codes Currently in Effect in San Francisco,” <http://www.sfdbi.org/index.aspx?page=69>, accessed April 13, 2010.

IMPACTS

Significance Criteria

The City and County of San Francisco has not formally adopted significance standards for impacts related to utilities. The Planning Department's Initial Study Checklist provides a framework of topics to be considered in evaluating potential impacts under CEQA.

Implementation of a project could have potentially significant impacts related to energy or telecommunications infrastructure if it were to:

- Require or result in the construction of new energy or telecommunications infrastructure, or expansion of existing facilities, the construction of which could cause significant environmental effects.

The question of whether there would be wasteful use of energy, as in the Initial Study Checklist, is dealt with in Section IV.Q, Minerals and Energy Resources.

Approach to Analysis

Typically, EIR's compare the electrical and natural gas demand from the project to the capacity of existing infrastructure. While this comparison is applicable to transmission capacity from Oakland to the Development Plan Area, the comparison is not applicable to distribution capacity within the Development Plan Area. This is because the Proposed Project includes an entirely new electrical and natural gas distribution system. Therefore, a detailed analysis of the capacity of particular switchgear and distribution lines or gas pipes on the Islands is not needed.

For the Proposed Project, electrical and natural gas demand estimates were created using an energy modeling software program called eQUEST.¹⁴¹ Engineers developed computer models of seven different generic building types, and made assumptions regarding their energy efficiency. See Section IV.Q, Mineral and Energy Resources, for further discussion.

It was not necessary to model the size of telecommunications distribution facilities, because the conveyance of digital signals does not require large conduits.

Proposed Project's Electricity and Natural Gas Demand

As discussed further in Section IV.Q, Minerals and Energy Resources, pp. IV.Q.13 – IV.Q.15, provided that the project sponsors adopt the recommendations of the *Treasure Island Development Energy Study*, the Proposed Project's electrical peak demand is estimated at 11.4

¹⁴¹ Arup North America Ltd., *Treasure Island Development Energy Study*, prepared for TICD, Dec. 2009, p. 9 (hereinafter "*Treasure Island Development Energy Study - 2009*"). A copy of this document is available for public review at the San Francisco Planning Department, 1650 Mission Street, Suite 400, in Case File No. 2007.0903E.

MW and annual electrical energy consumption at 58,500 MWh.¹⁴² The Proposed Project's peak natural gas demand is estimated at 42.6 million British thermal units per hour ("Btu/hr") and annual gas consumption at 980,000 therms per year.¹⁴³ Total annual energy consumption would be approximately 297,500 million Btu/yr. As discussed in Section IV.Q, Mineral and Energy Resources, pp. IV.Q.10 – IV.Q.15, these estimates assume various strategies for energy demand reduction ("iteration #4"), using reasonable assumptions of what would be expected to be built, given regulatory requirements, Treasure Island Green Building Specifications, and typical construction practices in the Bay Area, including meeting a LEED Gold equivalent, energy conservation measures, no space cooling provided for low-rise and medium-rise residential buildings, and using gas-fired baseboard heating for these residential buildings. Also, these estimates are for full build-out and include energy demands associated with new infrastructure (e.g., wastewater treatment) as well as existing uses to be retained.

Proposed Project Facilities

The following discussion includes preliminary concepts for the proposed electricity and natural gas systems. As discussed in Chapter II, Project Description, master utility plans for the electrical and gas system service would be prepared in coordination with the SFPUC. Long-term aspirational goals in the Sustainability Plan for Treasure Island are to reduce energy demand, create sustainable supply, and achieve carbon neutrality.¹⁴⁴

Electricity

Under the Proposed Project, most of the electric power would be generated off-site. The Term Sheet states, "The Authority [TIDA] anticipates that the Project will continue to purchase all of its electricity from Hetch Hetchy Water and Power [¹⁴⁵], or other City sources so long as it is reasonably available for the Project's needs, the level of service is substantially equivalent or better than that available on the open market, it can be separately metered and implemented at comparable business terms and without additional delay (including delivery of service to construction sites), and the price is equivalent or less than then prevailing market rates for comparable types of loads."¹⁴⁶ In addition, on-site renewable energy could be developed or caused to be developed by the power provider, TICD, or other vertical developers (e.g., rooftop solar panels), and/or by third-party power providers. The project sponsors have committed to meeting 5 percent of peak electric demand with on-site renewable sources, such as (but not limited to), solar photovoltaics.

¹⁴² *Ibid*, p. 1.

¹⁴³ *Ibid*, Treasure Island Energy Iteration Comparison, following p. 23.

¹⁴⁴ 2006 Treasure Island Sustainability Plan, p. 39.

¹⁴⁵ Hetch Hetchy Water and Power is the name of the entity, and does not mean the dam and reservoir called Hetch Hetchy.

¹⁴⁶ 2006 Term Sheet, Section IV(D), p. 25.

Under the Proposed Project, all heating and cooling would be provided at the individual building level and independent from adjacent buildings. Chapter VI, Project Variants, discusses possible District Energy Plants and other variants to the approach to providing heating and cooling.

The following discussion begins with the transmission of electric power to the Islands.

Electricity Distribution to Treasure Island

The existing 12 kV distribution line described in the Setting would continue to be used. It has sufficient capability to transmit peak demand via the distribution facilities from the Davis Substation in Oakland to the submarine cables (as discussed under “Setting”) to carry the estimated peak (coincident) demand for the Proposed Project.¹⁴⁷

The electrical service to Treasure Island from Oakland is considered a “radial service,” i.e., it has one point of connection to the grid. For demand less than 20 MW, PG&E does not typically require a redundant service point for reliability.¹⁴⁸

Although the capacity is sufficient, a number of upgrades to the existing off-site electrical system could be made to improve capacity and reliability. Figure IV.K.7: Proposed Off-Site Electrical System shows the proposed off-site electrical facilities that would support the Proposed Project. These are discussed in Chapter VI, Project Variants, Section F, “Off-Site Electrical Distribution Improvements.”

● *Distribution System on Treasure Island and Yerba Buena Island*

The existing electrical distribution system on Treasure Island would be completely replaced in phases during project buildout (with the exception of the infrastructure within the Jobs Corps and Coast Guard properties). Starting at the terminus of the submarine cables, the new distribution system would include a new switchgear in an outdoor fenced enclosure (i.e., 15 kV class) located near the southeast corner of Treasure Island. The submarine cables would be connected to this switchgear through separate breakers, providing a redundant supply.¹⁴⁹ The switchgear would provide connection points for the two existing trailer-mounted diesel generators, which would remain on-island as a back-up source.

The distribution system throughout the Proposed Project would consist of looped 600 amp, 12 kV, main underground feeder system, with radial and looped 200 amp circuits feeding transformers and service cables to residential and commercial buildings.

¹⁴⁷ *Infrastructure Update*, Chapter 11, 8/18/2009 Addendum, Section 11.2.4.

¹⁴⁸ *Infrastructure Update*, Chapter 11, 8/18/2009 Addendum, Section 11.2.2.

¹⁴⁹ *Infrastructure Update*, Chapter 11, Addendum, Section 11.2.4.

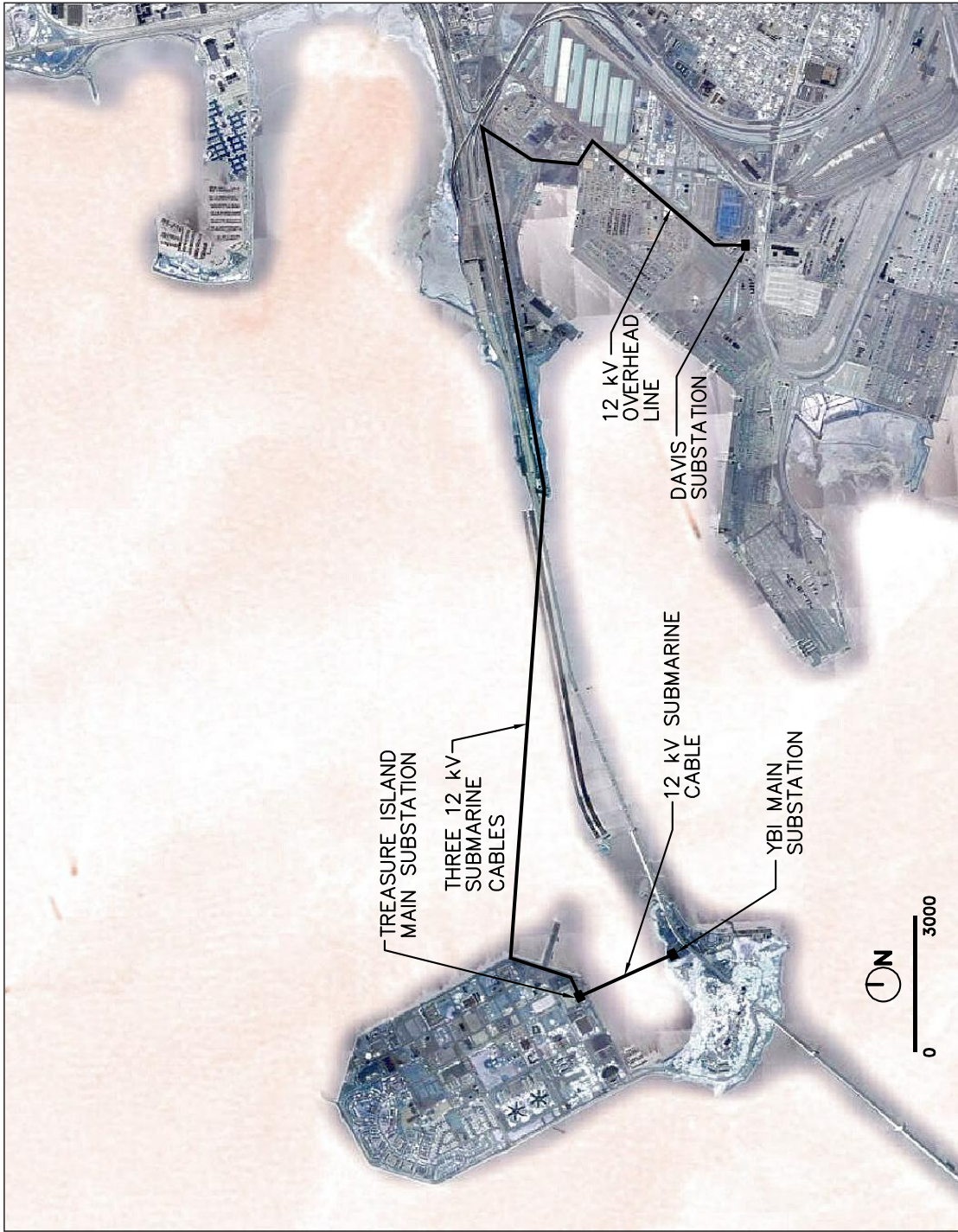

SOURCE: BKF

TREASURE ISLAND AND YERBA BUENA ISLAND REDEVELOPMENT PROJECT EIR

FIGURE IV.K.7: PROPOSED OFF-SITE ELECTRICAL SYSTEM

A joint utility trench would follow the proposed roadway layout, and would accommodate electric, natural gas, telecommunications, and cable television lines. Existing service lines would remain in place until new service is established, to avoid interruptions.

- Utility service to the Job Corps campus and buildings would be maintained throughout the phased buildout of the Proposed Project. Electricity service to the Job Corps campus would be more robust under the Proposed Project. Certain modifications of connections would be necessary at the perimeter of the Job Corps site. Details would be worked out during the design process for each major phase.
- Electrical service to the property line of the Coast Guard Station and Sector Facility would be maintained during buildout of the Proposed Project. Certain modifications to the connections may be necessary. Details would be worked out during the design process.
- TIDA and the Coast Guard have agreed that they would enter into a construction coordination Memorandum of Understanding (MOU).¹⁵⁰ The MOU would include (among other things) a process for the Coast Guard to notify TIDA when it is considering modernization projects, so that utility-demand modifications can be coordinated. Regarding future electrical demand, the Coast Guard has no details for its future expansion or modernization plans at this time. Modernization plans may be more energy intensive, since new technology often requires more power than older equipment. However, because no modernization projects are currently defined, it is too speculative to estimate a future increase in electricity use for the Coast Guard.

Electricity Supply

SFPUC Electric Resources. As described under “Setting” above, the SFPUC generates power from hydroelectric facilities in the Sierra Nevada Mountains and also purchases power. As discussed further in Section IV.Q, Mineral and Energy Resources, these electric resources would provide most of the electricity for the Proposed Project.

On-Site Renewable Generation. The Infrastructure Plan includes renewable electricity generation on Treasure Island, including photovoltaic solar power and possibly small, vertical-axis wind turbines. The project sponsors have committed to meeting 5 percent of peak electric demand with on-site renewable sources, such as (but not limited to), solar photovoltaic.¹⁵¹ This target would be achieved by designing building rooftops to accommodate photovoltaic systems, potentially using solar water heating, and potentially implementing demonstration-level wind energy production.

● ¹⁵⁰ This information is based on the results of a meeting between TIDA, TICD, and U.S. Coast Guard representatives held on October 29, 2010.

¹⁵¹ *Infrastructure Update*, Chapter 11, 8/18/2009 Addendum, p. 5 and Section 11.8.

IV. Environmental Setting and Impacts
K. Utilities and Service Systems

The Proposed Project would permit development of either ground-mounted or roof-mounted photovoltaic systems. With current technology, about 1.4 to 3 acres of photovoltaic panels would be required to meet the goal of 5 percent of the peak power demand. Roof-mounted and/or ground-mounted panels would satisfy this goal. The Proposed Project would include sufficient rooftops to provide space for 1.4 to 3 acres of photovoltaic panels, and the draft *Design for Development* permits rooftop-mounted photovoltaic systems on all buildings, including historic Buildings 1, 2, and 3.

The types of wind power systems are not known. Changes in technology are expected over the next few years as site preparation activities are being conducted that make it difficult to accurately predict the precise nature of the equipment likely to be used. Therefore, wind energy production facilities and locations are expected to be selected at some time in the future and would undergo appropriate environmental review at that time.

Emergency Back-up Power. The Proposed Project would use the existing, two, trailer-mounted diesel-powered generators (2 MW capacity each) currently owned by the SFPUC, to provide for

emergency back-up power. The generators would be relocated from their existing location near Building 3 to a place near the new switchgear. These generators would be sufficient to provide power for critical needs during a blackout.

Proposed Natural Gas Infrastructure

Under the Proposed Project, natural gas would be conveyed to the Islands, and distributed by PG&E. All heating and cooling would be provided at the individual building level and independent from the adjacent buildings.

As discussed under electricity above, the Proposed Project would include on-site renewable energy. No particular target has been established for renewable energy to take the place of natural gas use, but if technologies such as solar hot water would be used, then some reduction of natural gas use for heating would occur.

Natural gas would be supplied to the Islands through the existing PG&E submarine pipeline. Portions of the pipeline have been upgraded as part of the construction of the east span of the Bay Bridge.

Proposed natural gas distribution lines would be installed in the joint utility trench described above. Unlike the existing system, these new distribution lines would be owned by PG&E and metered for downstream users. As with electrical service, existing gas lines would be left in place until new infrastructure has been completed to avoid interruptions in service. Construction of new gas distribution would generally correspond to the phases of building construction on Treasure Island.

- Utility service to the Job Corps campus and buildings would be maintained throughout the phased buildout of the Proposed Project. Natural gas service to the Job Corps campus would be more robust under the Proposed Project. Certain modifications of connections would be necessary at the perimeter of the Job Corps site. Details would be worked out during the design
- process for each major phase. The Coast Guard does not currently have natural gas service, so the Proposed Project would not need to maintain service during construction. The Proposed Project would continue to provide natural gas service to Yerba Buena Island to serve the new development. If in the future, the U.S. Coast Guard wishes to add natural gas service for the Coast Guard facilities on Yerba Buena Island, the service could tie in to the supply lines on Yerba Buena Island.

Proposed Telecommunications Project Facilities

The entire telecommunication system (land-based telephone and cable television) would be replaced as part of the Development Program. Project sponsors would identify, and negotiate with, telecommunication service providers to design and construct a system to serve the Islands. It is anticipated that the major links of the telecommunication distribution network would be included in the joint utilities trench described above. If cellular telephone service towers are needed, they would likely be built on top of one or more of the taller proposed buildings.

- Utility service to the Job Corps campus and buildings would be maintained throughout the phased buildout of the Proposed Project. Telecommunications service to the Job Corps campus would be more robust under the Proposed Project. Certain modifications of connections would be necessary at the perimeter of the Job Corps site. Details would be worked out during the design process for each major phase.
- The Coast Guard Station and Sector Facility is updating its telecommunications and computer systems. Land-based telecommunications services to the property line of the Coast Guard Station and Sector Facility would be maintained during buildout of the Proposed Project. Certain modifications to the connections may be necessary. Details would be worked out during the design process. As discussed above on p. IV.K.78, TIDA and the Coast Guard have agreed that they would enter into a construction coordination Memorandum of Understanding (MOU). The MOU would include (among other things) a process for the Coast Guard to notify TIDA when it is considering modernization projects, so that utility-demand modifications can be coordinated.

Project Impacts

Construction

Impact UT-15: Construction activities associated with energy and telecommunication infrastructure of the Proposed Project could result in air quality, noise, water quality, transportation, hazardous materials, cultural resources, and biological impacts, as further evaluated under those EIR topics. (See *Significance Determinations in other topics.*)

As discussed above, the Proposed Project would include replacement of the electrical, natural gas, and telecommunications distribution infrastructure serving Treasure Island and Yerba Buena Island (up to the property lines of the Jobs Corps and Coast Guard). The existing infrastructure would continue to operate until new infrastructure is ready, following in sequence with the overall development construction phasing. In addition, repairs and upgrades to existing infrastructure would continue as needed until replacement.¹⁵²

The second significance criterion, above, indicates that the Proposed Project would have a significant adverse effect if it would require, or result in, the construction of new energy or telecommunications infrastructure, where the construction would cause significant environmental effects. Demolition, land clearing, grading, and other ground-disturbing construction activities would temporarily affect local air quality during each construction phase, causing temporary and intermittent increases in particulate dust and other pollutants. Operation of construction trucks

¹⁵² *Infrastructure Update*, Chapter 11, 8/18/2009 Addendum, Section 11.6.

IV. Environmental Setting and Impacts
K. Utilities and Service Systems

and heavy equipment would create fugitive dust and emit nitrogen oxides, carbon monoxide, sulfur dioxide, reactive organic gases or hydrocarbons, and particulate matter, as a result of diesel fuel combustion. Use of hazardous materials in new construction could result in emissions of toxic air contaminants. Construction activities and heavy equipment would also cause temporary and intermittent increases in noise during each construction phase. Excavation may result in release of volatile contaminants in the ground or groundwater, and excavated soils could contain hazardous materials. Construction activities could pollute run-off from construction areas. Construction trucks and other vehicles could cause transportation impacts on local roads and/or the Bay Bridge. Construction involving, or near, historical structures could damage those structures. Construction activities could adversely affect biological resources.

Impacts of construction, including energy or telecommunications infrastructure, and any related mitigation measures are discussed in Section IV.E, Transportation, pp. IV.E.67 – IV.E.71 (Impact TR-1); Section IV.F, Noise, pp. IV.F.14 – IV.F.20 (Impacts NO-1 and NO-2); Section IV.G, Air Quality, pp. IV.G.24-IV.G.38 (Impacts AQ-1 – AQ-4); Section IV.M, Biological Resources, pp. IV.M.41-IV.M.63 (Impacts BI-1 – BI-6); Section IV.O, Hydrology and Water Quality, pp. IV.O.35 – IV.O.41 (Impacts HY-1 – HY-7); and Section IV.P, Hazards and Hazardous Materials, pp. IV.P.39 – IV.P.51 (Impacts HZ-1 – HZ-9).

Operation

There is no environmental-impact significance criterion regarding adequacy of electricity, natural gas, and telecommunications delivery infrastructure. Although the existing electricity, natural gas, and telecommunications delivery infrastructure on Treasure Island and Yerba Buena Island would be inadequate to serve the development program, entirely new infrastructure would be part of the Proposed Project. As explained above, this new infrastructure would be adequate to serve the needs of the Proposed Project.

See Section IV.Q, Mineral and Energy Resources, for discussion of energy demand and supply.

Cumulative Impacts

Impact UT-16: Construction and operation of the Proposed Project would not result in cumulative impacts on energy and telecommunication infrastructure. (*No Impact*)

As discussed above, construction of the electricity, natural gas, and telecommunications delivery infrastructure would add incrementally to the dust, noise, traffic, and other impacts of construction of the Proposed Project. However, their contribution to these impacts would be small compared to the geotechnical stabilization, street construction, and building construction activities to develop the Proposed Project, in combination with ongoing construction of the Bay Bridge East Span project and the Yerba Buena Island Ramps Improvement Project.

Upon completion, electricity, natural gas, and telecommunications delivery infrastructure would be mostly underground. It would not generate appreciable noise, impede traffic, or emit air pollution.

There would be no significant cumulative impacts regarding construction or operation of the electricity, natural gas, and telecommunications delivery infrastructure.

L. PUBLIC SERVICES

This section of the EIR discusses police protection; fire protection and emergency medical services; public school facilities; hospitals; and public libraries. The Setting discussion describes the existing baseline conditions for police protection, fire protection, and public school facilities serving the Project Site. These facilities are shown on Figure IV.L.1: Police and Fire Stations, Schools, Hospitals, and Libraries in Northeast San Francisco. The Impacts discussions address whether the Proposed Project would require new or expanded facilities to provide the same levels of public services as currently exist. These sections also consider the contribution of the Proposed Project and other reasonably foreseeable development projects in San Francisco to cumulative environmental impacts related to police protection services, fire protection and emergency medical services, public school facilities, hospitals, and public libraries.

L.1 POLICE

SETTING

The San Francisco Police Department (“SFPD”), headquartered at 850 Bryant Street, provides public safety services in the City and County of San Francisco, including Treasure Island and Yerba Buena Island. The SFPD consists of three Bureaus (Operations, Administrative Services, and Chief of Staff) and ten Districts located throughout the City. Police services are made up of four basic activities: responding to citizens’ requests for service; initiating activities designed to promote order and detect or deter criminal behavior; conducting administrative tasks; and engaging in community policing (attending community meetings; working with community groups, businesses, schools, and other government agencies to prevent and control crime violence and disorder; meeting informally with residents and business people; working on problem-solving projects).

An organizational assessment of the SFPD, completed in December 2008, recommended a structure for allocating patrol officers’ time among all four of these activities.¹ Findings from the study indicate that, in 2007, the proportion of time spent on calls for service varied between 30.0 percent and 50.7 percent among San Francisco’s ten police districts. Citywide, the average was 42.9 percent.

Crimes recorded by the SFPD are organized into two groups: Part I crimes include aggravated assault, arson, breaking into cars, burglary, homicide, larceny, auto theft, rape, and robbery.

¹ The Police Executive Research Forum, *Organizational Assessment of the San Francisco Police Department: A Technical Report Final Report*, December 2008 (“Organizational Assessment”), available at <http://co.sfgov.org/webreports/details.aspx?id=761>, accessed on December 9, 2009.

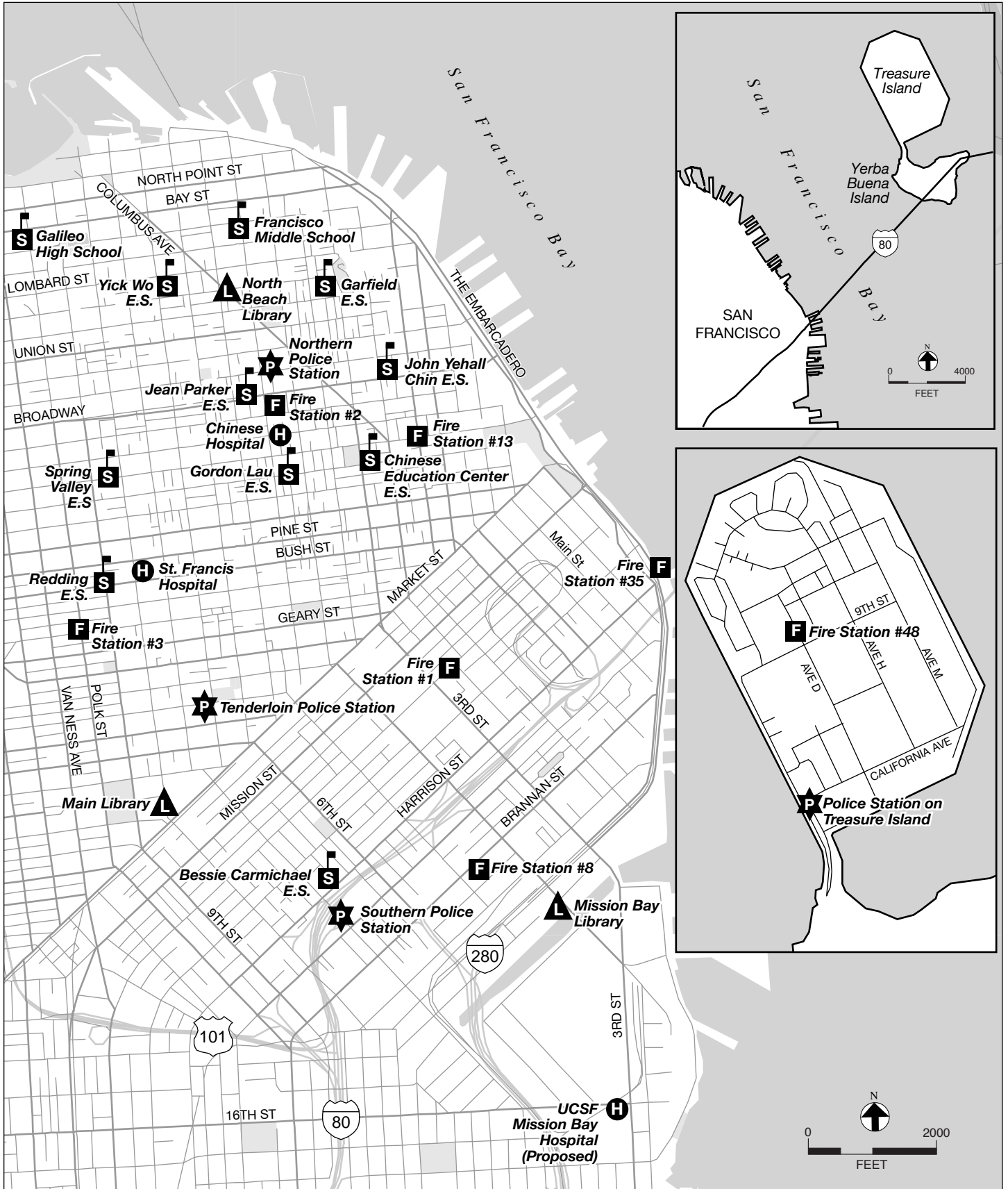

SOURCE: Turnstone Consulting

E.S. = ELEMENTARY SCHOOL

TREASURE ISLAND AND YERBA BUENA ISLAND REDEVELOPMENT PROJECT EIR

FIGURE IV.L.1: POLICE AND FIRE STATIONS, SCHOOLS, HOSPITALS, AND LIBRARIES IN NORTHEAST SAN FRANCISCO

Part II crimes range from disorderly conduct to receiving stolen property; they include embezzlement, forgery, gambling, prostitution, sex offenses, and other non-violent offences.

Staffing

The SFPD does not have an adopted standard for the ratio of officers to population or developed acreage, and bases its staffing levels on the number of service calls and crime incidents.² In 2007, the most recent data available, the Police Department employed approximately 2,650 people, of which 2,374 (90 percent) were uniformed officers.³ Authorized staffing at each District Station includes 1 captain, 4 lieutenants and 16 sergeants, as well as members of the Patrol Division, which, together with the Traffic Division, make up the Field Operations Bureau. The Patrol Division, supported by Field Operations Bureau staff, is responsible for community policing throughout San Francisco by car and on foot. The number of patrol officers is based on the population and crime statistics reported within the District. The SFPD has over 65 Beat Patrol geographical areas.

Southern Police District

The SFPD Southern District (covering about 6.5 percent of the City's land area) is one of San Francisco's ten police districts.⁴ The Project Area lies within the Southern District, which is based in the Southern Police Station, shown on Figure IV.L.1, located at 850 Bryant Street in the Hall of Justice. Police operating from this station provide service to Treasure Island and Yerba Buena Island in addition to the SOMA, Rincon Hill, South Beach, and North Mission Bay neighborhoods in San Francisco located south of Market Street and north of the Mission District and China Basin Channel. These neighborhoods differ in density and income levels from each other and the existing communities on Treasure Island and Yerba Buena Island. Southern Station personnel include district command staff, administrative officers, and patrol officers. In total, there were 144 sworn officers in 2007, the latest year for which statistics were available.⁵ The Southern Station receives on average 2,688 calls for service per week, which are dispatched from the City of San Francisco Emergency Communication Division.

The number of officers on patrol varies by shift, which are staggered throughout the day. The SFPD has increasingly focused their efforts on community policing strategies to improve public safety and empower residents to collaborate with police to improve neighborhoods. In the

² City and County of San Francisco, San Francisco City Charter Section 4.127 states that the City is to maintain a staffing level of a minimum of 1,971 sworn officers.

³ The Police Department had 2,449 budgeted positions for uniformed officers, of which 2,374 were filled, which represents approximately 97 percent of budgeted positions.

⁴ Public Safety Strategies Group, *San Francisco Police Department District Station Boundaries Analysis—Final Report*, May 13, 2008, (“*District Boundaries Analysis*”) p. 28. <http://sf-police.org/Modules/ShowDocument.aspx?documentid=14684>, accessed June 19, 2010.

⁵ *District Boundaries Analysis*, p. D1.

Southern District, over 20 Neighborhood Watch Programs have been implemented,⁶ including one on Treasure Island.⁷ In addition, there are six beat areas with foot patrols within the Southern District.⁸ The Police Department also operates programs for youth based at community centers.

Treasure Island Police Station

There is an existing police station that provides police protection services for the Islands located in Building 1 on Treasure Island. The Treasure Island Police Station is staffed with a force of 1 lieutenant, 3 sergeants, 12 officers, and 3 security guards. The Treasure Island station handles all calls for service on the Islands and most calls involving the San Francisco Oakland Bay Bridge. The SFPD motorcycle training facility is also located on Treasure Island.

Crime Incidents

According to SFPD records, a total of 7,178 Part I crimes were reported in the Southern District in 2007, which constitutes approximately 17 percent of reported Part I crimes citywide (42,071 total incidents). A total of 5,735 Part II crimes were reported in the Southern District in 2007, or about 13 percent of reported Part II crimes citywide (44,196 total incidents). These are the highest numbers for any district in San Francisco. For comparison, based on the 2000 Census data, the Southern District accounted for approximately 3.1 percent of the total City population (24,157 residents in SOMA compared to 776,733 San Francisco residents).⁹ Calls for services in the Southern District occupied an average of 44.7 percent of patrol officers' time in 2007.

In 2008 there were a combined total of 299 Part I and Part II crimes reported on the Islands. This constitutes a small proportion, 1.8 percent, of the 2008 reported crime level in the Southern District, which had a total of 16,680 reported Part I and Part II crimes. In 2009, of the 15,975 reported crimes in the Southern District, 218 crimes were committed on the Islands, or about 1.4 percent of the total crimes in the Southern District for that year.¹⁰

Response Time

The type of police response varies according to the nature and urgency of the call. In San Francisco, the following four call priorities have been established:

⁶ SFPD, *San Francisco Community Policing: A Report on Current Efforts*, November 2006, p. 13.

⁷ Treasure Island Online, at http://www.treasureislandonline.net/index.php?option=com_content&task=view&id=609&Itemid=80, accessed June 19, 2010.

⁸ Beat officers patrol the same beat on the same watch for at least a year.

⁹ *District Boundaries Analysis*, p. 28.

¹⁰ Facsimile from SFPD Media Relations, Officer Bo Mariles, in response to request of Michael Tymoff, Office of Economic and Workforce Development, TIDA, February 8, 2010. A copy of this document is available for public review at the San Francisco Planning Department, 1650 Mission Street, Suite 400, in Case File No. 2007.0903E. A breakdown between Part I and Part II crimes was not available.

- Priority A calls are defined as involving a “Life-threatening emergency.” These calls are the highest priority.
- Priority B calls are defined as involving “Potential for harm to life and/or property.” These calls are the second priority.
- Priority C calls are defined as involving “Crime committed with no threat to life or property. Suspect left crime scene.” These calls are third in priority.
- Priority I calls are “Information only broadcast, e.g. public disturbance. Caller wants to remain anonymous.”

In the SFPD’s “Performance Measures” established as part of the City’s 2008–2009 budget, the department established the following target response times for 2008–2009:

- Priority A Calls – 4.4 minutes,
- Priority B Calls – 8.3 minutes, and
- Priority C Calls – 10.8 minutes.

The 2007 Citywide average response times were reported in the SFPD *District Station Boundaries Analysis*. In 2007, the overall average response time in the Southern District for Priority A calls was 4.8 minutes, the longest response time in San Francisco. The response times for Priority B (15.7 minutes) and Priority C (15.5 minutes) calls were similarly the slowest in the City.¹¹ In 2007, Southern Station received 8,050 Priority A calls, 18, 297 Priority B Calls, and 20,416 Priority C calls, for a total of 46,763 calls. There were also 52,092 “on-view” incidents, where a police officer observed situations that required police attention.¹² While, in general, police department response times vary depending on a number of factors, including types of calls received and proximity of the nearest vehicle, response times in the Southern District generally have not met performance measure targets.

In 2008, the Islands Station received 265 Priority A calls, 574 Priority B calls, and 6,271 Priority C calls, which is a small proportion of the overall call volume in the Southern District. The response times for the Islands Police Station was 4.57 minutes for Priority A calls, 7.13 for Priority B calls, and 10.6 minutes for Priority C calls. The Islands Station performance fell within the Performance Measures set forth in the City’s 2008–2009 budget for Priority B and C calls, and not substantially over the performance measure for Priority A calls.¹³

¹¹ *Organizational Assessment*, p. 87.

¹² San Francisco Police Department, 2007 Annual Report, <http://sf-police.org/Modules/ShowDocument.aspx?documentid=14893>, accessed on June 19, 2010.

¹³ Email from Lt. Lyn Tomioka, February 22, 2010. A copy of this document is available for public review at the San Francisco Planning Department, 1650 Mission Street, Suite 400, in Case File No. 2007.0903E.

Demand for Police Services

Land use and location affect the types of incidents that prompt calls for police assistance. Residents tend to call police regarding domestic disturbances, neighborhood disputes, burglaries, or drug sales, while calls from retail establishments are generally to report shoplifting and traffic incidents. Calls from offices have a higher proportion of burglaries (auto or personal items) compared to other uses, and calls from entertainment uses depend largely on the type of tenants; for example, busy nightclubs often have a higher proportion of physical altercations.

As identified in the *District Boundaries Analysis*, one factor affecting the demand for police services is personal and family income. In the Southern District, similar to the Tenderloin, Mission, Bayview, Northern, and Central Districts, which are areas with 20 to 50 percent of the population living below the poverty level, there is a consistently higher recorded need for police services. As a correlation, the current poverty level on the Islands is not above the Citywide average, and does not place high demand on existing police services.

Regulatory Framework

Local

The *San Francisco General Plan Community Facilities Element* contains Objectives and Policies relevant to police station planning, including Objectives 1 and 2 and their underlying policies:

- Objective 1: Distribute, locate, and design police facilities in a manner that will enhance the effective, efficient and responsive performance of police functions.
 - Policy 1.1: Locate police functions that are best conducted on a centralized basis in a police headquarters building.
 - Policy 1.2: Provide the number of district stations that balance service effectiveness with community desires for neighborhood police facilities.
 - Policy 1.3: Enhance closer police/community interaction through the decentralization of police services that need not be centralized.
 - Policy 1.4: Distribute, locate, and design police support facilities so as to maximize their effectiveness, use, and accessibility for police personnel.
 - Policy 1.5: As they require replacement, relocate existing nonconforming facilities consistent with community desires for neighborhood police facilities.

In light of the high community value attached to parks in San Francisco, the preservation and restoration of park areas to park use is a long-range objective. Under the Recreation and Open Space Element of the General Plan, police facilities in designated recreation and open space areas are nonconforming uses. As these facilities become obsolete and require replacement, they should be relocated, consistent with the location and neighborhood service policies of this plan, and consistent with community desires for continued location of a district station in the neighborhood.

- Policy 1.6: Design facilities to allow for flexibility, future expansion, full operation in the event of a seismic emergency, and security and safety for personnel, while still maintaining an inviting appearance that is in scale with neighborhood development.
- Policy 1.7: Combine police facilities with other public uses whenever multi-use facilities support planning goals, fulfill neighborhood needs, and meet police service needs.
- Objective 2: Locate and design facilities in a manner that encourages constructive police/neighborhood interaction.
- Policy 2.1: Provide expanded police/community relations and police services through outreach programs, primarily utilizing existing facilities.
- Policy 2.2: Establish police district boundaries along natural neighborhood edges, and reinforce neighborhood identity by locating district stations near the centers of their service areas.
- Policy 2.3: Design police facilities to maximize opportunities for promoting community/police relations through dual use of facilities.

IMPACTS

Significance Criteria

The City and County of San Francisco has not formally adopted significance thresholds for impacts related to police services. The Planning Department Initial Study Checklist Form provides a framework of topics to be considered in evaluating potential impacts under CEQA. Implementation of a project could have a potentially significant impact related to police services if the project were to:

- Result in substantial adverse physical impacts associated with the provision of new or physically altered governmental facilities, [or the] need for new or physically altered governmental facilities, the construction of which could cause significant environmental impacts, in order to maintain acceptable service ratios, response times, or other performance objectives of the San Francisco Police Department.

Approach to Analysis

Impacts on police protection services are considered significant if an increase in population or development levels as a result of the Proposed Project would result in inadequate staffing levels, increased response times, and/or increased demand for services that would require construction or expansion of new or altered facilities that themselves could have an adverse physical effect on the environment. Thus, a significant impact would occur if the proposed Treasure Island Police Station could not accommodate the number of officers required to meet Proposed Project demand, or require the construction of a new or expanded police facilities that would cause significant environmental impacts. The information used to assess the impacts on police protection services was obtained from the SFPD and a review of the Public Safety Strategies

Group's assessment of facilities needs. Additionally, the Proposed Project's potential contribution to cumulative impacts is evaluated in the context of existing, proposed, and reasonably foreseeable future development expected.

Project Impacts

Construction Impacts

Impact PS-1: Project construction activities could result in adverse physical impacts or in the need for new or physically altered facilities in order to maintain acceptable service ratios, response times, or other performance objectives for police protection. (*Less than Significant with Mitigation*)

The Proposed Project, including construction of the new joint Police-Fire station on Treasure Island, could result in construction-related impacts on existing police services provided on the Islands. The existing police station on Treasure Island would serve the Project Area during Phase 1 of construction. As described on pages II.78 and II.85, Phase 1 construction would include ground and soil improvements in the initial development areas on Treasure Island, and construction of initial backbone infrastructure on the Islands. Thus, Phase 1 construction would not be expected to increase demand for police services. Existing police staffing and facilities would be adequate to maintain existing response times and other performance objectives. A new, centrally located, joint Police-Fire station would be constructed in Phase 2, along with the initial development of residential units, retail and hotel uses, and renovation of Building 2 on Treasure Island. (Refer to the Project Description, pp. II.79–II.82, for a description of construction phases.) Thus, the Proposed Project would not result in significant construction-related impacts on police services during the interim period that the Islands would continue to be served by the existing police station and staff and, therefore, no mitigation is required.

Construction activities could result in increased demand for police services if construction activities cause traffic conflicts requiring SFPD response. Access to the Development Plan Area site during construction would be maintained with implementation of a Construction Traffic Management Plan ("CTMP"), as required by Mitigation Measure M-TR-1, discussed in Section IV.E, Transportation, p. IV.E.69. The CTMP would provide necessary information to various contractors and agencies about how to maximize the opportunities for complementing construction management measures and to minimize the possibility of conflicting impacts on the roadway system, while safely accommodating the traveling public in the area. A cohesive program of operational and demand management strategies designed to maintain acceptable levels of traffic flow during periods of construction activities on the Islands would be implemented. These could include construction strategies, demand management strategies, alternate route strategies, and public information strategies.

Construction activities also could increase demand for SFPD services if a particular construction site is not adequately secured, providing increased opportunity for criminal activity. This increased demand during construction would not require construction of new or expanded police facilities because there would be no substantial increase in population or employment during the initial phases of construction. Additionally, the joint Police-Fire station would be constructed during Phase 2 and would provide increased staffing and patrols on the Islands during subsequent phases of construction.

Potential impacts associated with the construction of the proposed new joint Police-Fire station have been addressed in this EIR in Section IV.E, Transportation, pp. IV.E.67 (Impact TR-1); Section IV.F, Noise, pp. IV.F.14-IV.F.20 (Impacts NO-1 and NO-2); Section IV.G, Air Quality, pp. IV.G.24-IV.G.38 (Impacts AQ-1, AQ-2, AQ-3, and AQ-4); Section IV.M, Biological Resources, pp. IV.M.41-IV.M.63 (Impacts BI-1, BI-2, BI-3, BI-4, and BI-6); Section IV.O, Hydrology and Water Quality, pp. IV.O.35-IV.O.41 (Impacts HY-1, HY-2, HY-3, HY-4, HY-5, HY-6, and HY-7)); and Section IV.P, Hazards and Hazardous Materials, pp. IV.P.39-IV.P.47 (Impacts HZ-1, HZ-2, HZ-3, HZ-4, HZ-5, and HZ-6). As discussed in these sections, construction impacts, including impacts associated with construction of the joint Police-Fire Station, would be less than significant, or could be mitigated to less-than-significant levels with implementation of mitigation measures. Therefore, no mitigation would be required.

Operational Impacts

Impact PS-2: Implementation of the Proposed Project would increase demand for police services that would result in the need to construct new police facilities in order to maintain acceptable service ratios, response times, or other performance objectives of the San Francisco Police Department. (*Less than Significant*)

Evaluating the need for increased SFPD staff when new development is planned involves considering the size, location, and character of the new development. In most instances, development within San Francisco occurs within a fully developed urban area, and the incremental increase in service area or service requirements associated with any one project is minimal.

However, in this instance, the Project Area is underutilized. Implementation of the Proposed Project would introduce new uses to the Islands (e.g., retail, entertainment, and open space), and would substantially increase the density of development on the Islands. At full buildout, the Proposed Project would result in a total residential population of about 18,640, plus a total employee population of about 2,920 employees in 2030. Refer to Section IV.C, Population and Housing, Tables IV.C.3 and IV.C.4 for estimates of total residential and employment populations on the Islands in 2030. Patrolling and responding to calls within the Project Area would require deployment of additional police services on the Islands.

To estimate personnel requirements for new projects, the SFPD considers the size of the incoming residential population and the expected or actual experience with calls for service from other potential uses of the site. Any potential increase in staffing at the SFPD Treasure Island Station would be expected to take place over time throughout the 20-year development period with the incremental addition of new housing and new non-residential land uses.

Although the City has not adopted staffing ratio standards, the existing level of service at the SFPD can be determined by comparing citywide police force staffing to total City population (including both residents and workers). Using a total City daytime population for San Francisco of 1,351,410 (including workers who commute into the City) and a police department staffing level of 2,033 in 2005, a Citywide ratio of 1 officer per 665 people was calculated. This ratio, if applied to the total projected resident and employee population of the Development Plan Project Area at full build-out, would result in a potential need for a total of about 32 police personnel to provide a comparable level of service on the Islands. Although the officer-to-population ratio yields a contingent of 32 police, the SFPD's planned staffing, based on the current and projected call and incident load at Treasure Island, calls for 6 sergeants and 40 officers.

Under the Proposed Project, a new joint Police-Fire Station of about 30,000 square feet would be built on block IC4, near the center of Treasure Island, on a site that is currently undeveloped.

Impacts on police protection services are considered significant if an increase in population or development levels would result in inadequate staffing levels (as measured by the ability of the SFPD to respond to call loads) or if increased demand for services that would require the construction or expansion of new or altered facilities that might have an adverse physical effect on the environment.

Since the police staff expected at the proposed joint Police-Fire station would be 6 sergeants and 40 officers,¹⁴ the officer-to-population ratio would be met, thus there would be no expected significant impacts to the level of police service on the Islands. Therefore, no mitigation would be required.

While the development of the Proposed Project would require construction of new joint Police-Fire Station facilities to maintain acceptable levels of police protection, potential impacts associated with the construction of this facility have been addressed in this EIR, as discussed under Impact PS-1 above.

¹⁴ Letter from Captain Albert Pardini, San Francisco Police Department, to Kyri McClellan, Base Reuse and Development, Re: Estimating Future Use Levels and Costs for Treasure/Yerba Buena Islands, September 30, 2004. A copy of this document is available for public review at the San Francisco Planning Department, 1650 Mission Street, Suite 400, in Case File No. 2007.0903E.

Cumulative Impacts

Impact PS-3: The Proposed Project's contribution to cumulative projects would not affect police department response times or performance objectives, nor would it contribute to the need to construct new police facilities. (*Less than Significant*)

There are two separate projects that are expected to occur in the vicinity of the Proposed Project. The first project is the Yerba Buena Island Ramps Improvement Project (Ramps Project), which includes the replacement of the freeway ramps on the east side of the Yerba Buena Island tunnel and the seismic upgrade of the viaduct connecting the Yerba Buena Island causeway to the Bay Bridge westbound ramps and to Hillcrest Road.¹⁵ The second project is the development of an expanded 400-slip marina at Clipper Cove.¹⁶ The landside services necessary to support the marina project are part of the Proposed Project. Neither of these projects would have a substantial impact on the public services in the vicinity. Therefore, there would be no significant cumulative impacts on demand for police protection as a result of these projects. The cumulative transportation effects of these two projects are analyzed in Section IV.E, Transportation.

Aside from those two projects, there is no other development proposed or under consideration in the vicinity. The cumulative impact with respect to the rest of San Francisco is minimal as San Francisco is to the west of the Islands, making police response from the mainland to the Islands difficult because of both the distance and the commonly congested traffic conditions on the Bay Bridge. As a result, the Proposed Project would be served primarily by on-Island police personnel and would not typically draw mainland police personnel away from other parts of the City. The Proposed Project would not result in cumulative impacts on police protection services that would affect police response times or performance objectives on the Islands or in the remainder of the City, nor would it cumulatively contribute to the need to construct police facilities, beyond the joint Police-Fire Station proposed as part of the Proposed Project. Thus, the Proposed Project would not have a considerable cumulative impact on police response times in San Francisco.

¹⁵ There are one off-ramp and two on-ramps in the westbound direction, and two off-ramps and one on-ramp in the eastbound direction. The ramps are accessed from a series of short bridges, or viaducts, on Yerba Buena Island. The existing eastbound on-ramp (on the east side of the Yerba Buena Island tunnel) is being replaced as part of the Bay Bridge East Span Seismic Safety Project. The Ramps Project which includes the replacement of the other ramps on the east side of the Yerba Buena Island tunnel and the seismic upgrade of the viaduct connecting the Yerba Buena Island causeway to the Bay Bridge westbound ramps and to Hillcrest Road, is a separate project from the Proposed Project and the Bay Bridge East Span Seismic Safety Project.

¹⁶ A proposal to redevelop and expand the existing marina from 100 to 400 slips was previously analyzed in the *Transfer and Reuse of Naval Station Treasure Island Final Environmental Impact Report*, certified on May 5, 2005. The marina expansion is not part of the Proposed Project; however, the landside facilities and improvements associated with the expanded marina are included in the Proposed Project.

L.2 FIRE AND EMERGENCY MEDICAL SERVICES

SETTING

The San Francisco Fire Department (“SFFD”) is responsible for protecting life and property throughout San Francisco from fires, natural disasters, and hazardous materials incidents.¹⁷ The SFFD also provides unified emergency medical services in the City, including basic life support and advanced life support services. In addition, several privately operated ambulance companies are authorized to provide basic and advanced life support services. Water supply for fire suppression in San Francisco is provided mainly from the potable supply, but is augmented by an auxiliary water supply system (“AWSS”) on the east side of San Francisco. The Islands currently do not have an AWSS system and use only potable water for firefighting.

The SFFD has approximately 1,700 firefighting and emergency personnel and consists of three divisions, divided into 10 battalions and 43 active stations located strategically throughout the City. Staffing at each station is determined based on the types of firefighting apparatuses each station maintains. Engines are staffed with one officer and three firefighters, and trucks are staffed with one officer and four firefighters.¹⁸ Ambulances are staffed with a driver and one paramedic specialist who provides pre-hospital advanced medical and trauma care.

Fire stations are strategically located in order to be able to reach emergencies in the surrounding area quickly. In San Francisco, response times are calculated from the time the dispatch is received and acknowledged at the station to the time the responding unit informs dispatch that it is on-scene. The SFFD target response time goal for Code 1 (non-emergency) calls is 8 minutes, for Code 2 (non life-threatening fire and medical emergencies) calls is 20 minutes, and for Code 3 (life-threatening fire and medical emergencies) calls is 5 minutes. Code 3 calls are the highest response priority. When responding to Code 3 calls, responding vehicles use flashing lights and sirens and cross intersections against control lights. The SFFD is currently in the 90th percentile for attainment of all the department’s response time goals.¹⁹

Of the 43 SFFD fire stations located throughout the City, one is located on Treasure Island and none are on Yerba Buena Island. Station 48 is located in Building 157, Avenue D at 10th Street on Treasure Island.

¹⁷ The mission of the Fire Department is stated on the City and County of San Francisco Fire Department website at <http://www.sf-fire.org/>, accessed April 20, 2010. The mission statement also includes fire prevention education and goals for the work environment.

¹⁸ The terms *fire engine* and *fire truck* represent different types of firefighting apparatus.

¹⁹ Office of the Controller, City and County of San Francisco, A Review of the San Francisco Fire-EMS System, April 2004, Appendix B. A copy of this document is available for public review at the San Francisco Planning Department, 1650 Mission Street, Suite 400, in Case File No. 2007.0903E.

Regulatory Framework

State

California Fire Code

State fire regulations are set forth in Sections 13000, *et seq.* of the California Health and Safety Code, which include regulations concerning building standards (as also set forth in Title 24 of the California Code of Regulations, the California Building Code), fire protection and notification systems, fire protection devices (such as extinguishers and smoke alarms, high-rise building and childcare facility standards), and fire suppression training.

Local

San Francisco Fire Code

The San Francisco Fire Code incorporates by reference the California Fire Code, with certain local amendments. The San Francisco Fire Code was revised in 2007 to regulate and govern the safeguarding of life and property from fire and explosion hazards arising from the storage, handling, and use of hazardous substances, materials and devices, and from conditions hazardous to life or property in the occupancy of buildings and premises; to provide for the issuance of permits, inspections, and other SFFD services; and the assessment and collection of fees for those permits, inspections, and services.

The SFFD reviews building plans to ensure that fire and life safety is provided and maintained in the buildings under its jurisdiction. SFFD plan review applies to all fire alarm and fire suppression systems and all of the following occupancy types:

- Assembly occupancies (including restaurants and other gathering places for 50 or more occupants);
- Educational occupancies (including commercial day care facilities);
- Hazardous occupancies (including automobile repair garages, body shops, fuel storage, and emergency generator installation);
- Storage occupancies where potential exists for high-piled storage (Fire Code § 112.2, Table 112-A);
- Institutional occupancies;
- High-rise buildings of all occupancies; and
- Residential occupancies, such as hotels, motels, lodging houses, residential care facilities, apartment houses, small-and large-family day care homes, and R-1 artisan buildings (excluding minor residential repairs such as kitchen and bath remodeling and dry rot repair).

In coordination with the San Francisco Department of Building Inspection, the SFFD conducts plan checks of building permit applications to ensure that all structures, occupancies, and systems outlined above are designed in accordance with the San Francisco Fire Code, including structures within the City that are under federal jurisdiction.

Section 511 (Local Fire Safety Feature Requirements) of the San Francisco Fire Code requires that buildings 200 feet or more in height must provide at least one elevator approved by the Fire Department for firefighter use under fire conditions. The section also requires that for buildings having floors used for human occupancy located more than 75 feet above the lowest level of Fire Department vehicle access, an air replenishment system shall be installed to provide a means for firefighters to refill air bottles for self-contained breathing apparatus through a permanently installed piping distribution system. The system shall be tested and maintained pursuant to the Fire Department Administration Bulletin.

San Francisco General Plan

The San Francisco General Plan Community Facilities Element contains Objectives and Policies relevant to fire station planning, including Objective 5 and its underlying principles. Objective 5 states that:

Development of a system of firehouses which will meet the operating requirements of the fire department in providing fire protection services and which will be in harmony with related public service facilities and with all other features and facilities of land development and transportation provided for in other sections of the general plan.

Principles

The following principles are an integral and basic part of the Fire Facilities Section:

In general, firehouses should be distributed throughout the city so that each firehouse has a primary service area extending within a radius of one-half mile. This spacing should vary in relation to population densities, building intensities and types of construction, the pattern of trafficways, and with the relative degree of fire hazard.

Firehouses should be located on streets close to and leading into major or secondary thoroughfares.

Firehouses should be so located that no topographic barriers require time-consuming detours within the primary service area of each firehouse.

IMPACTS

Significance Criteria

The City and County of San Francisco has not formally adopted significance thresholds for impacts related to fire protection and emergency medical services. The Planning Department Initial Study Checklist Form provides a framework of topics to be considered in evaluating

potential impacts under CEQA. Implementation of a project could have a potentially significant impact related to fire protection and emergency medical services if it were to:

- Result in substantial adverse physical impacts associated with the provision of new or physically altered governmental facilities, [or the] need for new or physically altered governmental facilities, the construction of which could cause significant environmental impacts, in order to maintain acceptable service ratios or other performance objectives of the San Francisco Fire Department.

Approach to Analysis

Impacts on fire protection and emergency medical services are considered significant if an increase in population or development levels as a result of the Proposed Project would result in inadequate staffing levels, increased response times, and/or increased demand for services requiring the construction or expansion of new or altered facilities beyond those included in the Proposed Project that could have an adverse physical effect on the environment. Thus, a significant impact would occur if the proposed combined Police-Fire Station could not accommodate the additional SFFD personnel needed to meet Proposed Project demand, or would require the construction of new or expanded police facilities that would cause significant environmental impacts. Additionally, the Proposed Project's potential contribution to cumulative impacts is evaluated in the context of existing, proposed, and reasonably foreseeable future development expected in the vicinity of the Project Site.

Project Impacts

Construction Impacts

Impact PS-4: Project construction activities could result in adverse physical impacts or in the need for new or physically altered facilities in order to maintain acceptable service ratios, response times, or other performance objectives for fire protection. (*Less than Significant with Mitigation*)

The Proposed Project could result in construction-related impacts due to potential impacts on existing fire services provided on the Islands, or the construction of the new joint Police-Fire station on Treasure Island. The existing fire station on Treasure Island would serve the Project Area during Phase 1 of construction, which would include ground and soil improvements in the initial development areas on Treasure Island, and construction of initial backbone infrastructure on the Islands. Phase 1 construction would not be expected to increase demand for fire services. Existing fire staffing and facilities would be adequate to maintain existing response times and other performance objectives. A new, centrally located, joint Police-Fire station would be constructed in Phase 2, along with the initial development of residential units, retail and hotel uses, and renovation of Building 2 on Treasure Island. The existing fire station would continue to operate until the new joint Police-Fire station is operational. Thus, the Proposed Project would not result in significant construction-related

impacts on fire protection services during the interim period while the Islands would continue to be served by the existing police station and staff and, therefore, no mitigation is required.

Emergency access throughout the Islands would be maintained with implementation of the Construction Traffic Management Plan as specified in Mitigation Measure M-TR-1, discussed in Section IV.E, Transportation, p. IV.E.69. Compliance with the CTMP would require that emergency access is not obstructed during construction activities. The CTMP would provide necessary information to various contractors and agencies as to how to maximize the opportunities for complementing construction management measures and to minimize the possibility of conflicting impacts on the roadway system, while safely accommodating the existing residents and employees on the Islands. As such, construction of the Proposed Project would not affect SFFD response times, nor would construction require expansion of, or replacement of, SFFD stations. With the adoption of Mitigation Measure M-TR-1, impacts during construction of the Proposed Project on fire protection services would be less than significant.

Construction-related impacts of the new Police-Fire station have been addressed in Section IV.E, Transportation, pp. IV.E.67 (Impact TR-1); Section IV.F, Noise, pp. IV.F.14-IV.F.20 (Impacts NO-1 and NO-2); Section IV.G, Air Quality, pp. IV.G.24-IV.G.38 (Impacts AQ-1, AQ-2, AQ-3, and AQ-4); Section IV.M, Biological Resources, pp. IV.M.41-IV.M.63 (Impacts BI-1, BI-2, BI-3, BI-4, and BI-6); Section IV.O, Hydrology and Water Quality, pp. IV.O.35-IV.O.41 (Impacts HY-1, HY-2, HY-3, HY-4, HY-5, HY-6, and HY-7); and Section IV.P, Hazards and Hazardous Materials, pp. IV.P.39-IV.P.47 (Impacts HZ-1, HZ-2, HZ-3, HZ-4, HZ-5, and HZ-6). As discussed in those sections, construction impacts, including construction of the joint Police-Fire Station, would be less than significant, or could be mitigated to less-than-significant levels with implementation of construction-related mitigation measures. Therefore, construction of the proposed joint Police-Fire Station would not result in significant environmental impacts.

Operational Impacts

Impact PS-5: Implementation of the Proposed Project would increase demand for fire services, which would result in the need to construct new fire service facilities in order to maintain acceptable service ratios, response times, or other performance objectives of the San Francisco Fire Department. (*No Impact*)

The Project Area is currently served by an existing SFFD fire station, Station 48, located on Avenue D at 10th Street on Treasure Island. The existing station would be closed as part of the Proposed Project and relocated to a joint San Francisco Police and Fire Station of about 30,000 square feet that would be built in block IC4, near the center of Treasure Island. Figure IV.L.1, p. IV.L.2, shows the locations of the existing SFFD station on Treasure Island and stations in northeastern San Francisco. The new, joint Police-Fire station would be

constructed in Phase 2 and would be equipped with 2 pumper engines, one ladder truck, an ambulance, and a spare ambulance, and be staffed with 16 Fire Department staff persons. All new development would be constructed in an area that is accessible from the proposed fire station. The existing station would be closed after the new joint Police-Fire station is completed and operational as part of Phase 2 construction activities.

Buildings constructed or rehabilitated as part of the Proposed Project would be more fire-resistant than existing structures on the Islands due to improvements in the building codes and the provision of automatic sprinklers. In addition, the majority of the new buildings would not be wood-framed structures sharing common walls.

For fire protection and suppression, the Proposed Project would rely on three water supply systems. The primary fire water supply would be the domestic water system, which includes water storage of 4 million gallons in two tanks on Yerba Buena Island. These tanks would provide water to hydrants on both Islands. In order to have access to water for firefighting in the event the supply lines providing domestic water to the Islands were ruptured, the Proposed Project would also include a supplemental system using recycled water. Recycled water from the waste water treatment plant would be stored in a 1.14 million gallon tank located at the northeast corner of Treasure Island near the wastewater treatment and recycled water plants. The recycled water would be distributed from the tank to a separate system of fire hydrants spaced to accommodate a 1,000-foot hose length, which would be able to reach the farthest building. This system would have backup power and redundant pumps for reliability. A second, separate supplemental system would also be provided drawing on Bay water, with two fire boat manifolds and two suction hydrants located along the southern shore of Treasure Island near the existing hangar buildings.

A supplemental firefighting water system is not planned for Yerba Buena Island, due to its steep topography, smaller size, and proximity to potable water storage tanks on the island and to water supply lines on the Bay Bridge. Refer to Section IV.K, Utilities and Service Systems, pp. IV.K.38-IV.K.47, for additional detail about water infrastructure, including the supplemental firefighting system.

With construction of the approximately 8,000 new residential units in the Development Plan Area, the number of residents on the Islands would increase to about 18,640 at full buildout. The new retail uses, hotels, educational facilities, and other uses on the Islands are expected to increase total employment to about 2,920 employees. The increased number of residents and employees on the Islands, combined with an increase in the number of buildings, would result in increased demand for fire protection and emergency medical service and the potential to increase response times.

Approximately 50 percent of all housing units are anticipated to be in low-rise buildings (building height 70 feet and lower); 35 percent would be in mid-rise buildings (generally buildings 70 to 125 feet in height) or neighborhood towers (building height between 125 and 240 feet); and 15 percent would be in high-rise buildings (building height greater than 240 feet). The tallest buildings would be located in and adjacent to the Island Center District, near the proposed Ferry Terminal and Transit Hub, with one 650-foot-tall building in the “Main Tower” height zone across California Avenue from Building 1 (see Figure II.6a: Treasure Island Maximum Height Limit Plan, in Chapter II, Project Description, p. II.25). All new buildings above 70 feet in the Development Plan Area would be subject to current state and local regulations governing fire and life safety in high-rise construction. The SFFD would review building plans to ensure that adequate fire and life safety measures are provided, including review of emergency access and egress; sprinkler systems; fire-rated design, construction and materials; restrictions on occupant loads; emergency lighting; smoke alarms; mechanical smoke control and emergency notification systems; hydrants; and roadway access for fire equipment.

Project demand for fire protection and emergency medical service is expected to increase as the phases of the Proposed Project are completed and buildings are occupied. To maintain acceptable response times, the SFFD may need to hire additional personnel, and/or redeploy existing personnel, and acquire and/or redeploy equipment to serve the Development Plan Area. The need for additional staff and/or equipment would not, in itself, constitute a significant environmental impact related to fire protection service unless it would “[r]esult in substantial adverse physical impacts associated with the provision of, or the need for, new or physically altered governmental facilities, the construction of which could cause significant environmental impacts.”

Implementation of the Proposed Project would increase demand for fire services; however, the demand would be met by the construction of a new joint Police-Fire Station included in the Proposed Project that would allow the SFFD to maintain acceptable response times on the Islands. The new joint Police-Fire Station would be located on Block IC4, as shown in Figure IV.A.2: Proposed Land Use Plan for Treasure Island, Section IV.A, Land Use and Land Use Planning, p. IV.A.17. The staffing, programming, and other characteristics would be flexible in response to future needs and conditions, as well as in accordance with future SFFD, City, and community priorities and resources. Thus, construction of the new joint Police-Fire Station would allow the SFFD to continue to meet its target response times for the Islands, due to its increased size and staffing capability and more central location. Therefore, increased demand for fire services could be accommodated such that response times would not be adversely affected. Construction of a new SFFD facility would therefore allow the SFFD to maintain acceptable

response times for fire protection and emergency medical services (3 minutes for Treasure Island and 6 minutes for Yerba Buena Island²⁰).

Although the Proposed Project would require new SFFD facilities to maintain acceptable levels of fire protection and emergency medical services, potential impacts associated with the construction of the new Police-Fire station have been addressed in this EIR as discussed under Impact PS-4 above.

Cumulative Impacts

Impact PS-6: The Proposed Project's contribution to cumulative impacts would not affect fire department response times or performance objectives, nor would it contribute to the need to construct new fire station facilities (*Less than Significant*)

Cumulative demand for fire protection and emergency medical service is expected to increase as the residences and commercial space in the Proposed Project and other reasonably foreseeable development projects are built and occupied in San Francisco over the analysis period. Although cumulative development may result in a demand for additional SFFD staff, that alone would not result in a significant physical environmental effect. The proposed Police-Fire station facilities included as part of the Proposed Project would not be greatly affected by cumulative San Francisco growth, as the Islands are not proximate to any other San Francisco neighborhood and are surrounded by the San Francisco Bay.

There are two separate projects that are expected to occur in the vicinity of the Proposed Project. The first project is the Ramps Project, which includes the replacement of the freeway ramps on the east side of the Yerba Buena Island tunnel and the seismic upgrade of the viaduct connecting the Yerba Buena Island causeway to the Bay Bridge westbound ramps and to Hillcrest Road. The second project is the development of an expanded 400-slip marina at Clipper Cove. Neither of these projects would have a substantial impact on the public services in the vicinity. Therefore, there would be no significant cumulative impacts on fire protection or emergency medical services as a result of these projects. The cumulative transportation effects of these two projects are analyzed in Section IV.E, Transportation.

The rest of San Francisco is west of the Islands, making fire and emergency medical response from the mainland to the Islands impractical, both because of the travel distance and the commonly congested state of the Bay Bridge. As a result, the Proposed Project would be served primarily by on-Island fire personnel and would not typically draw mainland Fire Department

²⁰ Memo from Jack Sylvan to Gary Massentani (San Francisco Fire Department), Re: Treasure Island and Yerba Buena Island Fire Protection, June 29, 2010. A copy of this document is available for public review at the San Francisco Planning Department, 1650 Mission Street, Suite 400, in Case File No. 2007.0903E.

personnel away from other parts of the City. The Proposed Project would not result in cumulative impacts on fire protection and emergency medical services that would affect SFFD response times or performance objectives on the Islands or in the remainder of the City, nor would it cumulatively contribute to the need to construct fire station facilities beyond the proposed joint Police-Fire station proposed as part of the Proposed Project. Thus, the Proposed Project would not have a considerable cumulative impact to fire and emergency response times in San Francisco.

L.3 SCHOOLS

SETTING

Existing School Facilities

Treasure Island and Yerba Buena Island are within the San Francisco Unified School District (“SFUSD”). The SFUSD oversees the public school system in San Francisco (K–12) and has 37 preschools and 104 schools serving various grade levels (K–5, K–8, and 9–12). Based on data for the 2008–2009 school year, there are approximately 56,000 students currently attending public schools in San Francisco. Approximately 20,000 students, 26 percent of the total student population in San Francisco, attend local private schools. From 1999 to 2008, student enrollment in the SFUSD declined by approximately 0.1 percent annually.²¹

SFUSD has capacity for approximately 63,835 students in existing facilities; there is additional capacity in elementary, middle, and high schools. Although neighborhoods with many school-age children generate a proportionally higher level of demand for nearby schools, SFUSD assigns students based on a lottery system. This system distributes students to facilities that have sufficient capacity. If a student is not assigned to a nearby school, SFUSD provides bus transportation to the assigned school. SFUSD provides bus transportation to approximately 5,300 elementary students attending 16 nonattendance area schools and 48 attendance area schools. SFUSD provides some transportation to Burton, Galileo, Mission, and Balboa high schools; however, most middle and high school students use public transportation.²²

Since student enrollment has been declining, SFUSD has been closing schools. SFUSD has focused on replacing older schools and modernizing facilities. The SFUSD Capital Plan identifies a range of physical improvements necessary to modernize existing facilities, such as providing Americans with Disabilities Act-compliant access, upgrading science and computer labs, and expanding arts facilities.

²¹ California Department of Education, DataQuest, <http://data1.cde.ca.gov/dataquest/>, accessed June 19, 2010. The same data source shows that there was a slight increase in the number of students in 2008–2009 from 56,222 to 56,454.

²² SFSUD website, <http://portal.sfusd.edu/template/default.cfm?page=policy.placement.transportation>, accessed June 19, 2010.

Student Assignment System

From the 2002-2003 academic year until the 2010-2011 academic year, the SFUSD operated a three-part, race-neutral, choice-based student assignment system that focused on outreach and recruitment, program placement, and a diversity index lottery. Under this system, the most significant determinants of a student's school assignment were parental choice and school capacity. Parents submitted an application with a list of ranked school choices, and the SFUSD assigned students based on available openings, attendance areas, and the diversity index lottery. Since the SFUSD allowed students to apply to any school in the City, schools with higher demand received more enrollment requests than seats available. Whenever enrollment requests were greater than the number of seats available, the SFUSD used the diversity index lottery to determine which students received an assignment offer. The diversity index lottery results were based on a formula that used race-neutral, factors including extreme poverty, socioeconomic status, student's home language, quality of student's prior school, and student's prior academic achievement.

In March 2010, this system was altered to create a hybrid system that, while retaining certain aspects of the prior system, places more weight on the test scores in a student's census tract and the student's proximity to a school, granting children in low-scoring tracts and children near a given school preferential status in the lottery system over other students.²³ The new system will be implemented starting with student assignments for the 2011-2012 school year.

For elementary schools, students would be chosen for high-demand schools using the following order of preferences:

1. Students with siblings in the school,
2. Students who attended preschool in the elementary school's attendance area,
3. Students in low-scoring census tracts,
4. Students in the preferred school's attendance area, and
5. All others applying.

For middle schools, students would be chosen for high-demand schools using the following order of preferences:

1. Students with siblings in the school,
2. Students in low-scoring census tracts,
3. Students in the preferred school's attendance area,
4. Students in densely populated attendance areas, and

²³ "S.F. Adopts New School Assignment System," Jill Tucker, *San Francisco Chronicle*, March 10, 2010.

5. All others applying.

For high school, students would be chosen for high-demand schools using the following order of preferences:

1. Students with siblings in the school,
2. Students in low-scoring census tracts,
3. All others applying.

When elementary school students are assigned to a school outside of their neighborhood, the district provides them with bus transportation to the assigned school. Busses are provided to some middle and high school students assigned to schools outside their neighborhoods, while the remainder rely on public or private transportation to travel to their assigned schools.

Project Area

There are currently no public schools operated by SFUSD on either Treasure Island or Yerba Buena Island. Treasure Island School, located at 13th and E Streets, is owned by the Navy and was formerly operated by the SFUSD until its closure in 2005. At that time, it had 88 students and a capacity for 676 students.²⁴ In 2001, 529 students from kindergarten through 8th grade were enrolled in Treasure Island School. Seven percent of these students were residents of the Islands; the rest were bused to Treasure Island from the Tenderloin, SOMA, Mission, and Chinatown neighborhoods.

There are several non-SFUSD educational institutions and programs on Treasure Island, most of which are located on the grounds of the former Treasure Island School. As of 2009, a portion of the buildings on the Treasure Island School site were being used for the Glide YouthBuild Program, the San Francisco's Sheriff's Five Keys Charter School, the Boys and Girls Clubs of San Francisco, and the San Francisco Police Department's motorcycle training unit. These programs and schools are on one-year leases with TIDA.

The Glide YouthBuild Program is a leadership and training program for 16- to 24-year-old youth from San Francisco's poorest and most violent neighborhoods. The program is partnered with John Muir Charter School, and includes on-site construction skills training, personal development and leadership skills workshops, GED preparation, and the ability to earn academic credit toward a high school diploma. It places graduates in apprenticeship opportunities with building trade unions (carpentry, drywall, ironwork, and cement masons). Glide's YouthBuild program has grown over the past few years, and thus sought out the larger 22,000-square-foot Treasure Island

²⁴ Beth Winegarner, "Rebirth for Treasure Island school?" *The San Francisco Examiner*, July 30, 2008, located at http://www.examiner.com/printa-1512738~Rebirth_for_Treasure_Island_school?.html, accessed on June 19, 2010.

School facility in 2008. The Treasure Island School has classrooms, a large auditorium, kitchen, garden, and nearby sports field that serves the Glide YouthBuild student programs. The additional space permitted an expansion of program capacity by about 30 percent, to a total of 114 students. The Treasure Island Clubhouse of the Boys & Girls Clubs of San Francisco is also located in the former Treasure Island School. This program provides after-school programs for youth in the areas of education, health & fitness, social recreation, and teen services. The Boys & Girls Clubs of San Francisco opened the Treasure Island Clubhouse in 2000. The San Francisco Sheriff's Five Keys Charter School is a GED program for formerly incarcerated women.

The 24,000-square-foot Life Learning Academy is currently open on Treasure Island at 651 8th Street, Building 229, between Avenues I and M, and is expected to remain on Treasure Island after Project buildout is complete. The Life Learning Academy is a Charter School founded in 1998, designed to serve 60 at-risk high school youths who have not been successful in traditional schools. The curriculum was developed by the Delancey Street Foundation as part of a juvenile justice reform effort to reduce youth incarceration and recidivism. Youth are referred to the Life Learning Academy by SFUSD, police, probation officers, and community-based organizations.

Since January 1, 2010, Catholic Charities has operated a child development center on Treasure Island. Catholic Charities is a member of the Treasure Island Homeless Development Initiative, which manages 250 units of housing for the homeless on Treasure Island.

The San Francisco Police Department's motorcycle training unit, located on Treasure Island, educates police officers on the proper handling of motorcycles for police duty. This use is not expected to continue under the Proposed Project.

Regulatory Framework

State

California Senate Bill 50 ("SB 50") and Proposition 1A were designed to construct and modernize California schools. According to Government Code Section 65996, the development fees authorized by SB 50 are deemed to be full and complete school facilities mitigation for increased development. The legislation also has provisions to adjust the fee periodically to keep pace with inflation. These provisions will remain in place as long as subsequent state bonds are approved and available. As a result of this legislation, school districts are expected to continue to levy a school fee on developers under existing rules (Government Code Sections 65995, 65995.5, and 65995.7).

Local

The SFUSD began collecting school impact fees authorized by the state under SB50 in 1987. School impact fees are collected from developers prior to issuance of building permits to mitigate

impacts associated with enrollment growth created by new development. The SFUSD collects fees for all construction and building permits issued within the City. Developer fee revenues are used, in conjunction with other SFUSD funds, to support efforts to complete capital improvement projects. The current fees for new construction, when building permits are issued, range from 9 cents per square foot for hotels to \$2.24 per square foot for residential construction, with other rates for office, research and development, hospitals, industrial, and retail and services uses.

IMPACTS

Significance Criteria

The City and County of San Francisco has not formally adopted significance thresholds for impacts related to school services. The Planning Department Initial Study Checklist Form provides a framework of topics to be considered in evaluating potential impacts under CEQA. Implementation of a project could have a potentially significant impact related to school services if it were to:

- Result in substantial adverse physical impacts associated with the provision of new or physically altered governmental facilities, [or the] need for new or physically altered governmental facilities, the construction of which could cause significant environmental impacts, in order to maintain acceptable service ratios or other performance objectives of the San Francisco Unified School District.

Approach to Analysis

Impacts on schools are considered significant if an increase in population or development levels as a result of the Proposed Project would result in inadequate staffing levels, overcrowding, and/or increased demand for services requiring the construction or expansion of new or altered facilities beyond those included in the Proposed Project that could have an adverse physical environmental effect. Thus, a significant impact would occur if the proposed rebuilt or renovated Treasure Island School could not accommodate the additional students expected with the Proposed Project, and would require the construction or expansion of new or expanded school facilities that would cause significant environmental impacts. Additionally, the Proposed Project's potential contribution to cumulative impacts is evaluated in the context of existing, proposed, and reasonably foreseeable future development expected in the vicinity of the Islands.

Project Impacts

Construction Impacts

Impact PS-7: Project construction activities would not result in adverse physical impacts or in the need to construct new or physically altered facilities in order to maintain acceptable staffing ratios, prevent overcrowding, or to meet other performance objectives for school services. (*Less than Significant*)

The Proposed Project, including renovation or rebuilding of the Treasure Island School, could result in construction-related impacts on existing educational and school services provided on the Islands. Construction would not, in itself, create new residents or any other impact on City schools. Construction-related impacts from re-building or renovating the Treasure Island School are addressed in this EIR in Section IV.E, Transportation, pp. IV.E.67 (Impact TR-1); Section IV.F, Noise, pp. IV.F.14-IV.F.20 (Impacts NO-1 and NO-2); Section IV.G, Air Quality, pp. IV.G.24-IV.G.38 (Impacts AQ-1, AQ-2, AQ-3, and AQ-4); Section IV.M, Biological Resources, pp. IV.M.41-IV.M.63 (Impacts BI-1, BI-2, BI-3, BI-4, and BI-6); Section IV.O, Hydrology and Water Quality, pp. IV.O.35-IV.O.41 (Impacts HY-1, HY-2, HY-3, HY-4, HY-5, HY-6, and HY-7)); and Section IV.P, Hazards and Hazardous Materials, pp. IV.P.39-IV.P.47 (Impacts HZ-1, HZ-2, HZ-3, HZ-4, HZ-5, and HZ-6). As discussed in those sections, construction impacts, including impacts from construction of a new or renovated Treasure Island School facility, would be less than significant, or could be mitigated to less-than-significant levels with implementation of mitigation measures.

Construction of the Proposed Project would not prevent access to existing educational programs on Treasure Island, as access would be maintained through compliance with the Construction Traffic Management Plan prepared for the Project, as required by Mitigation Measure M-TR-1, discussed in Section IV.E, Transportation, p. IV.E.69. Compliance with the CTMP would ensure that access to educational programs on Treasure Island and access to schools located off the Islands by Island residents is not obstructed during construction activities. Thus, construction impacts to the schools and educational programs would be considered less than significant.

Operational Impacts

Impact PS-8: Implementation of the Proposed Project would increase demand for school services that would result in the need to construct new school facilities in order to maintain acceptable service ratios or other performance objectives of the San Francisco Unified School District. (*Less than Significant*)

The Proposed Project would renovate and expand or construct a new school of up to 105,000 square feet at the site of the existing 30,000-square-foot Treasure Island School to serve the future school age children who would reside on the Islands. Assuming 8,000 housing units, the SFUSD expects about 1,695 students would live on the Islands. The new school would likely serve pre-

- kindergarten (preschool), elementary, and middle school students;²⁵ high school students would most likely continue to attend schools in other parts of San Francisco.²⁶ For planning purposes, about 48 preschool aged children were estimated.²⁷ The remaining 1,647 students were distributed evenly by grade. As shown in Table IV.L.1, a total of approximately 1,695 school-age children would live on the Islands following full build-out of the Project. As of 2009, approximately 320 students live on the Islands.²⁸

Table IV.L.1 presents the student enrollment that would likely be generated as a result of the Proposed Project, based on generation rates used by the SFUSD.²⁹ While 26 percent of the total school-age children in San Francisco now attend private schools, Table IV.L.1 conservatively assumes that 100 percent of the school-age children associated with the Proposed Project would attend public schools.

Comparing the 2008 SFUSD school capacity of 63,835 to a projected 2030 school population of 71,573 school age students, there would be a future shortfall of about 7,738 places, or about a 12 percent shortfall. The proposed Treasure Island School would help alleviate this shortfall by providing room for about 2,000 additional elementary and middle school students. The projected 520 high school students on the Islands would need to travel to existing or future SFUSD facilities off the Islands, the effects of which are considered in Section IV.E, Transportation. Currently, high school assignment in SFUSD is undertaken in a complex lottery process, with busing provided in certain areas. Future students on the Islands would be expected to use a variety of modes of travel to school, including cars, mass transit, and school buses.

²⁵ As explained in note 3 to Table IV.L.1, the capacity of the renovated or constructed Treasure Island School was based on a combined elementary and middle school, both of average size within the SFUSD. If the Treasure Island School is built to this size, then it is expected that SFUSD would bus other San Francisco elementary and middle school students to the Treasure Island School.

²⁶ Letter of Carlos Garcia, Superintendent of Schools, SFUSD, of August 3, 2009. A copy of this document is available for public review at the San Francisco Planning Department, 1650 Mission Street, Suite 400, in Case File No. 2007.0903E.

- ²⁷ Factor is based on the 2010 SFUSD Child Development Center (CDC) enrollment of 1,559 students, or about 2.86 percent of total 2010 SFUSD student enrollment. (1,695 students x 0.0286 = about 48 preschool aged students.)

²⁸ Data is from 2008-2009 school year. On the Islands, there are 131 high school students (personal communication w/ Michael Tymoff, Mayor's Office of Work Force and Economic Development, May 27, 2010), 127 elementary school students, and 62 middle school students (elementary and middle school numbers for 2008 school year found in <http://portal.sfusd.edu/data/epc/Comparison%20of%20student%20residences%20with%20location%20of%20school%20attended.pdf>, accessed June 2, 2010)

²⁹ Letter of Carlos Garcia, Superintendent of Schools, SFUSD, of August 3, 2009. A copy of this document is available for public review at the San Francisco Planning Department, 1650 Mission Street, Suite 400, in Case File No. 2007.0903E.

● **Table IV.L.1: Public School Enrollment at Project Buildout Compared to SFUSD Capacity**

Area	Preschool / Elementary School (Grades Preschool-5)	Middle School (Grades 6-8)	High School (Grades 9-12)	Total
Project Area (estimated)	808	380	507	1,695
2030 Citywide Enrollment ¹	33,036	16,518	22,024	71,573
2009 SFUSD Capacity	29,260	11,700	17,575	63,835 ²
2030 Projected Shortfall	3,776	4,818	4,449	7,738
New Treasure Island School Capacity ³	1,200	800	0	2,000

Notes:

¹ Categories may not add up to total due to rounding.

² Total includes capacity for 5,300 students in varying grade levels in alternative schools and public charter schools.

³ Based on combined average size of elementary and middle schools within SFUSD. See Comparison of Number of Students Living in Each SF City Planning Neighborhood with Elementary and Middle School Capacity, found at <http://portal.sfusd.edu/data/epc/Comparison%20of%20Number%20of%20Students%20Living%20in%20Each%20SF%20City%20Planning%20Nhood.pdf>, accessed June 20, 2010.

Source: ABAG Projections, 2007; Turnstone Consulting, 2009.

As discussed in the Setting section, improvements are planned for many SFUSD schools, including replacing older schools and modernizing other facilities. The San Francisco Unified School District Capital Plan identifies a range of physical improvements necessary to modernize existing facilities, such as providing access compliant with the Americans with Disabilities Act, upgrading science and computer labs, expanding arts facilities, among other improvements. Those improvements will improve accessibility, add new laboratories, provide better access to computing technology, and provide other advantages over existing facilities. The proposed Treasure Island School would provide elementary and middle school capacity, but would not provide facilities for the additional 520 high school students generated by the Proposed Project. To accommodate these high school students, SFUSD would use the allocation system in place at the time to place students in existing high schools.

Increased enrollment resulting in school overcrowding is considered to be a social, rather than a physical, environmental impact and would not be a significant environmental impact requiring mitigation under CEQA.³⁰ However, increased enrollment may lead to a secondary physical environmental impact if the increase in enrollment would require physical changes in the environment, such as constructing a new school, changing bus routes, and altering traffic patterns. California Government Code Sections 65995 and 65996 limit the ability of cities to mitigate

³⁰ Goleta Union School District vs. Regents of University of California (1995, 2nd Dist.) 37 Cal.App.4th 1025.

school impacts. Pursuant to these sections, a lead agency is required to mitigate school impacts beyond State-mandated fees only when a physical environmental effect beyond the mere addition of students to a school occurs. Residential growth in the City would be addressed by SB 50 fees, and these fees may increase school capacity by the time students are living in the Proposed Project's residential units. In addition, the Proposed Project is expected to include a new or rehabilitated Treasure Island School, to partially address the expected Citywide shortfall.³¹

SFUSD could also choose to address future shortfalls by shifting students to other facilities, beginning year-round schools, and/or increasing the use of portable classrooms. While the new or rehabilitated Treasure Island School would be included in the Proposed Project, the capacity of that facility would not be sufficient to meet the City's expected future overcapacity problem resulting from citywide population growth. The school impact fees paid pursuant to SB 50 would improve school capacity to accommodate growth in school attendance.

Therefore, the Treasure Island school included in the Proposed Project, plus payment of the school impact fees as required by SB 50, would ensure that future facilities are provided. Therefore, this impact would be less than significant.

Although the Proposed Project would require renovating or rebuilding the Treasure Island School to maintain acceptable staffing ratios, prevent overcrowding or to meet other performance objectives for school services, potential impacts associated with the renovation or construction of the new school have been addressed in this EIR as discussed under Impact PS-5 above.

Implementation of the Proposed Project would not have significant impacts on schools and educational programs currently located on the Treasure Island School site that would result in the need for new construction or expansion of existing facilities. All of these educational uses would be eligible to seek leased space in the community facility spaces that would be included in the Proposed Project. The Treasure Island School would be rebuilt or renovated in Phase 2 of construction. At the time of Phase 2 construction, educational uses located on the school site would be required to relocate. The Life Learning Academy and the Treasure Island Clubhouse of the Boys & Girls Clubs of San Francisco are expected to remain on the Islands and transition to other Island facilities. Other educational programs operated by community organizations and the San Francisco Police Department are on one-year leases and would either relocate off-site or lease space in the community facilities included in the Proposed Project. Therefore, implementation of the proposed project, which would include rebuilding or renovation of the Treasure Island School, would not require construction of new or expanded governmental school

³¹ Even though the expected capacity of 2,000 students exceeds the number of students expected to live in the Proposed Project (1,695), an estimated 520 of those students in the Proposed Project would be high school students, who could not be accommodated at the Treasure Island School and would contribute to the districtwide shortfall.

facilities to accommodate existing schools on the Islands or elsewhere, and would result in less-than-significant environmental impacts on schools.

Cumulative Impacts

Impact PS-9: The Proposed Project cumulative contribution would not result in additional demand for educational facilities (*Less than Significant*)

Cumulative impacts on schools could result if the demand created by the Proposed Project, when combined with other proposed projects or existing conditions, required physical environmental changes such that the construction of additional school facilities in and of themselves would cause significant environmental impacts.

The two projects expected to occur in the vicinity of the Proposed Project, the Ramps Project and the expanded 400-slip marina at Clipper Cove, would not have a substantial impact on the public services in the vicinity. Therefore, there would be no significant cumulative impacts on schools as a result of these projects. The cumulative transportation effects of these two projects are analyzed in Section IV.E, Transportation.

The Proposed Project would contribute to the demand for educational facilities in San Francisco generated by population growth, including that from other large proposed developments at Parkmerced in the southwest quadrant of the city and Hunters Point and Candlestick Point in the southeast quadrant of the city. Increased demand for schools generated by the Proposed Project would be partially offset by the rehabilitation or construction of the Treasure Island School. Additionally, under SB 50 and Government Code Section 65996, the payment of development fees by the Project Sponsors is deemed “full and complete school facilities mitigation” for the additional demand created by development. Thus, the Proposed Project’s impacts on schools would not be cumulatively considerable and would be less than significant, and no mitigation would be required.

L.4 HOSPITALS

SETTING

As shown in Figure IV.L.1, p. IV.L.2, there are no hospitals on the Islands. The City and County of San Francisco, Department of Public Health (“DPH”), operates San Francisco General Hospital (“SFGH”) and has programs to provide medical care to all its citizens, including residents of the Islands. DPH also provides a number of public medical clinics throughout the City.³² These public clinics are all City-run facilities where primary care can be received;

³² These include the Castro-Mission Health Center, the Children’s Health Center at SFGH, the Chinatown Health Center, the Curry Senior Center, the Family Health Center at SFGH, the General Medical Clinic

none are located on the Islands. In addition, the City has affiliated with various other facilities to provide primary health care; none of these facilities are located on the Islands.³³

San Francisco has seven privately-run hospital systems providing inpatient care.³⁴ Three of these hospital systems—California Pacific Medical Center (“CPMC”), Kaiser Permanente (“Kaiser”), and University of California, San Francisco (“UCSF”) Medical Center—operate hospital facilities at more than one location. St. Francis Memorial and St. Mary’s Medical Center are separate facilities, and are both part of the Catholic Healthcare West system.

In 2006, according to the latest data available from the Office of Statewide Health Planning and Development, San Francisco hospitals (excluding the Veterans Affairs Medical Center) had a total of 2,736 staffed inpatient beds, of which 1,961 were in use on average. CPMC had about one-third of the City’s daily hospital census; UCSF maintained approximately one-quarter, and San Francisco General Hospital another 19 percent.³⁵ Thus, there are more hospital beds in San Francisco than patients.³⁶

SFGH provides a full complement of inpatient, outpatient, emergency, skilled nursing, diagnostic, mental health, and rehabilitation services for adults and children. It is the largest acute inpatient and rehabilitation hospital for psychiatric patients in the City. Additionally, it is the only acute hospital in San Francisco that provides 24-hour psychiatric emergency services and operates the only Trauma Center (Level 1) for the 1.5 million residents of San Francisco and northern San Mateo County. Because of this, ambulances are likely to bring those injured on the Islands to SFGH for emergency medical care. Currently, 30 percent of all ambulances within San Francisco go to SFGH, and 20 percent of all hospital patients are treated there. SFGH is located at 1001 Potrero Avenue, approximately 7 miles from the Islands. As part of its Rebuild Program, SFGH is currently constructing a new, approximately 422,144 gross-square-foot, 284-bed (increase of

at SFGH, the Maxine Hall Health Center, the Ocean Park Health Center, the Potrero Hill Health Center, the Silver Avenue Family Health Center, the Southeast Health Center, and the STD Clinic on 7th Street.

³³ These include Glide Health Services, Haight Ashbury Free Clinics, Lyon-Martin Women's Health Services, Mission Neighborhood Health Center, Native American Health Center, North East Medical Services, San Francisco Community Clinic Consortium, San Francisco Free Clinic, South of Market Health Center, and St. Anthony Free Clinic.

³⁴ The City and County of San Francisco also operates Laguna Honda Hospital to provide long-term care, rehabilitation, and skilled nursing services to adult residents of San Francisco who are disabled or chronically ill. Laguna Honda does not provide inpatient services.

³⁵ *California Pacific Medical Center, 2008 Institutional Master Plan (CPMC IMP)*, The Marchese Company, available on the internet at: http://www.rebuildcpmc.org/assets/08IMP_CPMC.pdf, accessed on June 19, 2010, p. 11.

³⁶ CPMC IMP, p. 11.

32 beds), acute care hospital and trauma center that will be completed in 2015 at its current location.³⁷

For non-trauma-related care, residents of the Islands would likely use one of several private hospitals in San Francisco, such as Chinese Hospital (845 Jackson Street, about 5 miles from the Islands), St. Francis Memorial Hospital (900 Hyde Street, about 7.5 miles from the Islands), CPMC's Pacific Campus (2333 Buchanan, about 8 miles from the Islands), Kaiser's Geary Campus (2425 Geary Boulevard, about 8.5 miles from the Islands), or Island residents could use hospitals in Oakland, such as Children's Hospital (5.6 miles from the Islands) or Kaiser Permanente Medical Center of Oakland (6 miles from the Islands). Once completed, the UCSF Mission Bay Hospital would be about 6 miles away from the Islands. There is also a proposal for a new California Pacific Medical Center hospital on Cathedral Hill, which is about 8 miles from the Islands.

IMPACTS

Significance Criteria

The City and County of San Francisco has not formally adopted significance thresholds for impacts related to hospital services. The Planning Department Initial Study Checklist from provides a framework of topics to be considered in evaluating potential impacts under CEQA. Implementation of a project could have a potentially significant impact related to hospital services if it were to:

- Result in substantial adverse physical impacts associated with the provision of new or physically altered governmental facilities, [or the] need for new or physically altered governmental facilities, the construction of which could cause significant environmental impacts, in order to maintain acceptable performance objectives of the San Francisco Public Health Department.

Approach to Analysis

Impacts on hospitals would be considered significant if an increase in population or development levels as a result of the Proposed Project would result in inadequate staffing levels, increased morbidity and mortality rates, and/or increased demand for services requiring the construction or expansion of new or altered facilities that could have an adverse physical effect on the environment. Thus, a significant impact would occur if the existing and projected hospitals could not accommodate the additional demand created by the Proposed Project, and a new facility would have to be constructed or an existing facility expanded, resulting in significant physical impacts. Additionally, the Proposed Project's potential contribution to cumulative impacts is

³⁷ San Francisco General Hospital, Rebuild Fact Sheet, updated, September 29, 2009. <http://www.sfdph.org/dph/RebuildSFGH/projectInfo/SFGHRebuildFactSht05242010.pdf>, accessed June 19, 2010.

evaluated in the context of existing, proposed, and reasonably foreseeable future development expected in the vicinity of the Proposed Project.

Project Impacts

Construction Impacts

Impact PS-10: Project construction would not result in adverse physical impacts or in the need to construct new or physically altered facilities in order to maintain adequate staffing levels, acceptable morbidity and mortality rates, or other performance objectives for hospital services. (*Less than Significant*)

There would be no hospital-related construction impacts, because project-related construction activities would not affect any existing hospital facilities. Although construction activities associated with the Proposed Project could result in injuries requiring use of hospital facilities, the increase in demand would be well within the capacity of existing local hospitals in San Francisco and Oakland. Construction would not prevent access to existing hospitals, as access would be maintained through compliance with the Construction Traffic Management Plan prepared for the Project, as required by Mitigation Measure M-TR-1, discussed in Section IV.E, Transportation, p. IV.E.69. Compliance with the CTMP would require that access to hospitals is not inhibited during construction activities. Thus, construction impacts to hospitals would be considered less than significant, and no mitigation is required.

Operational Impacts

Impact PS-11: Implementation of the Proposed Project would not increase demand for hospital services that would result in the need to construct new hospital facilities in order to maintain adequate staffing levels, acceptable morbidity and mortality rates, or other performance objectives of the San Francisco Public Health Department. (*No Impact*)

While there are no studies or numerical measures to determine whether a city has sufficient hospital coverage, there are more staffed hospital beds in San Francisco than patients. Of the 2,376 staffed hospital beds in the City, an average of 1,961 beds are in use on any given day. Because there is sufficient capacity at existing and proposed hospitals, the addition of new residents or employees on the Islands who would be potential patients would not be sufficient to require the construction of new or expanded hospital facilities in San Francisco. Thus, the addition of 18,640 persons on the Islands would not create a significant impact on hospital service, and no mitigation is required.

Cumulative Impacts

Impact PS-12: The Proposed Project's cumulative contribution would not increase demand for hospital services that would result in the need to construct new hospital facilities in order to maintain adequate staffing levels, acceptable morbidity and mortality rates, or other performance objectives of the San Francisco Public Health Department. (No Impact)

Cumulative impacts on hospital care would result if demand created by the Proposed Project, added to demand from other proposed development projects, were to require the construction of additional hospital facilities. The two projects expected to occur in the vicinity of the Proposed Project, the Ramps Project and the expanded 400-slip marina at Clipper Cove, would not have a substantial impact on the public services in the vicinity. Therefore, there would be no significant cumulative impacts on hospitals as a result of these projects. Reasonably foreseeable future development projects within the City, including growth in the southeast and southwest quadrants at Hunters Point/Candlestick Point and at Parkmerced, would increase the City's resident population in 2030 to about 922,600,³⁸ of which the Proposed Project would constitute 2 percent, resulting in increased demand for hospital and other medical resources.

The Proposed Project and the reasonably foreseeable development projects would add to the demand on hospital facilities in San Francisco and Oakland. However, the capacity of existing and planned hospital facilities in San Francisco is greater than the current demand. Thus, the additional demand would be met, and the Proposed Project would not result in considerable cumulative impacts on hospital services that would require the need to construct other new or expanded hospital facilities.

L.5 LIBRARIES

SETTING

The San Francisco Public Library ("SFPL") operates the Main Library at Civic Center and 28 neighborhood branches distributed throughout San Francisco. During the 2007–2008 fiscal year, the main library had a collection of about 1.3 million volumes³⁹ and, combined, all of the branch libraries had a collection of 1,203,126 volumes, for a SFPL total of 2,500,979 volumes.⁴⁰ Community-based branch libraries, as well as the Main Library, provide reading rooms, book lending, information services, access to technology, and library-sponsored public programs. Most branches offer an event almost every day, often for pre-school and elementary school

³⁸ The basis for population projections is discussed in Section IV.C, Population and Housing, p. IV.C.2.

³⁹ San Francisco Public Library website, <http://sfpl.org/pdf/about/policies/collection-development-plan.pdf>, p. 4 (accessed on June 20, 2010).

⁴⁰ San Francisco Public Library Collection Size Fact Sheet. A copy of this document is available for public review at the San Francisco Planning Department, 1650 Mission Street, Suite 400, in Case File No. 2007.0903E.

children: story time, crafts, and videos. Programs for youth include reading and computer-oriented clubs.

All SFPL branch libraries offer books at adult, teen, and children’s reading levels. Basic collections consist of fiction, nonfiction, and reference books; magazines; newspapers; audio books; CDs; and DVDS. If specific materials are not available at a SFPL branch, items may be obtained electronically through the library’s ebook system, or through interlibrary loan.⁴¹ Interlibrary loan involves loaning items from various libraries and institutions in North America that agree to loan items to one another.⁴² Most of SFPL’s collection of electronic resources is accessible from all branch locations and online 24 hours a day at the SFPL website.

As shown in Figure IV.L.1, p. IV.L.2 and described in Table IV.L.2: Library Branches Near the Islands, there are four branch libraries within a 6-mile radius of the Islands: the Chinatown Branch, Mission Bay Branch, the Main Library, and the North Beach Branch. In addition, residents of the Islands may consider using libraries in the East Bay, including the main Oakland Library at 125 14th Street (about 9 miles away), and the Berkeley City Library at 2090 Kittredge (about 10 miles away).

Table IV.L.2: Library Branches Near the Islands

Branch	Location	Distance from the Islands	Status	Size of Library in Square Feet (SF)
Chinatown	1135 Powell St.	5.5 miles	Open	17,858 SF
North Beach	2000 Mason St.	6 miles	Open; new library in design stage	5,330 SF (current) ¹ 8,500 SF (proposed)
Mission Bay	960 4th St.	5 miles	Opened 2009	7,500 SF ²
Main Library	100 Larkin	5.4 miles	Open	375,000 SF ³

Note:

¹ Data from <http://sfpl.org/pdf/blip/northbeachdesign.pdf>, accessed June 14, 2010.

² Data from <http://www.sfpl.org/pdf/blip/missionbayfaq.pdf>, accessed June 14, 2010.

³ Data from <http://sfpl.org/index.php?pg=2000023201>, accessed June 14, 2010.

Source: Email from Brian Bannon, San Francisco Public Library, June 11, 2010, available as part of the project file in the San Francisco Planning Department, 650 Mission Street, Suite 400, San Francisco, file 2007.0903E. .

The Chinatown library offers the largest public collection in Northern California of Chinese language materials and English books on Asian interest topics, as well as a sizable number of materials in Vietnamese. Twice the size of the original library built in 1921, the branch holds more than 90,000 books, periodicals, newspapers, video and audio media. An extensive file is also maintained of pamphlets, newspaper and magazine articles on Chinatown's history and issues

⁴¹ San Francisco Public Library . <http://sfpl.org/index.php?pg=0000000301>, accessed June 20, 2010.

⁴² San Francisco Public Library . <http://sfpl.org/index.php?pg=2000031901>, accessed June 20, 2010.

of concern to the Chinese and Asian American community. A new community meeting room and roof garden are available for public use, by reservation. The Children's department has more than 25,000 English and Chinese picture stories, fiction, non-fiction and general reference materials, periodicals, video and audio cassettes, computers, board games, plus books in 15 other languages. There is also a storytelling room and a computer lab with software in English and Chinese. Bilingual staff members are available to assist patrons.⁴³

The Mission Bay Branch Library has a medium-size collection of Chinese-language materials, a small collection of Russian language materials, and a small collection of Spanish language materials.

The Main Library has multiple collections in many different languages and houses the African-American Center; the Art, Music, and Recreation Center; the Chinese Center; the Deaf Services Center; the Environmental Center; the Government Information Center; the Filipino American Center; the Gay and Lesbian Center; the International Center; the Jobs and Careers Center; the Magazines and Newspapers Center; the Patent and Trademark Center; the San Francisco History Center; the Small Business Center; and the Teen Center. The Main Library also has the Koret Auditorium which holds 235 people; a café; and the typewriter room.

The existing North Beach Branch Library is being redesigned as part of the Branch Library Improvement Program (“BLIP”), discussed below.

In 1994, San Francisco voters passed Proposition E, a Charter amendment that created the Library Preservation Fund. This measure established a dedicated fund to be used to provide library services and materials, as well as to operate library facilities. Proposition E requires the City to maintain funding for the San Francisco Public Library at a level no lower than the amount it spent during the 1992–1993 fiscal year. Voters renewed the Library Preservation Fund in November 2007 (Proposition D).

Branch Library Improvement Program

The Branch Library Improvement Program was launched as a result of a bond measure passed in November 2000 to provide \$106 million in funding to upgrade San Francisco’s branch library system, and Proposition D, which passed in November 2007, authorizing additional funding to improve the branches. The BLIP is intended to provide the public with seismically safe, accessible, technologically updated, and code-compliant City-owned branch libraries in every neighborhood.⁴⁴ Improvements to be made at each branch were determined through the

⁴³ <http://www.sanfranciscochinatown.com/attractions/library.html>, visited June 18, 2010.

⁴⁴ San Francisco Public Library, Branch Library Improvement Program—Frequently Asked Questions, 2009. <http://www.sfpl.org/index.php?pg=2000002301>, accessed on June 20, 2010.

preparation of a Community Needs Assessment for each branch, with public meetings, community surveys, and outreach to neighborhood organizations.

Design options, such as public meeting rooms, more computers, separate teen facilities, child and adult reading areas, and other library services, were considered. Choices about each branch reflect its budget (which is fixed), input from staff, and input from the neighborhood, in part through community meetings to discuss services and architectural plans.

The SFPL has implemented a number of interim programs to serve the public while branches are closed for renovation or replacement. These include increasing hours at nearby branches, holding programs at neighborhood schools and community centers, and offering bookmobile services.

New library branches have since been constructed or are currently being constructed. The new one-story, 6,300-square-foot Mission Bay branch opened in February 2009. The branch opened with a collection of 34,000 items and has room to grow by an additional 10 percent to 15 percent. Construction of the new Visitacion Valley branch began in summer 2007 and is scheduled to be completed in 2010. The North Beach Branch redesign was also authorized under Proposition D. Under Proposition D, the North Beach project budget was increased from \$3.7 million to between \$7.6 and \$8.4 million, and the project scope was expanded from a renovation to a brand new building. The SFPL also undertook a Master Planning process for the adjacent park, in conjunction with the Recreation & Park Department, with the goal of deciding where in relation to the park the new larger library should be located. Three community meetings were held (July 2003, December 2008, and February 2009), plus an additional three public meetings in 2008 and 2009, followed by design presentations in late 2008 and in 2009. The redesign process is underway, and as the design process moves forward, the Library will hold additional community meetings.⁴⁵

Regulatory Framework

Local

San Francisco Public Library Strategic Plan (2003–2006)

The SFPL Strategic Plan was adopted in 2003 and is the guiding policy and planning document for the SFPL. The SFPL Strategic Plan does not set a standard for library service. Instead, each library must evaluate how it may best meet the needs of the community. To this end, the SFPL has developed the Strategic Plan, which provides every library facility and program with a unifying organizational vision and systemwide goals. These goals are broad and flexible so that services can be tailored to the unique needs of each neighborhood.

⁴⁵ San Francisco Library, North Beach Library website, <http://www.sfpl.org/index.php?pg=2000087601>, accessed June 20, 2010.

IMPACTS

Significance Criteria

The City and County of San Francisco has not formally adopted significance thresholds for impacts related to library services. The Planning Department Initial Study Checklist form provides a framework of topics to be considered in evaluating potential impacts under CEQA. Implementation of a project could have potentially significant impacts related to library services if it were to:

- Result in substantial adverse physical impacts associated with the provision of new or physically altered governmental facilities, [or the] need for new or physically altered governmental facilities, the construction of which could cause significant environmental impacts, in order to maintain acceptable levels of service or other performance objectives of the San Francisco Public Library system.

Approach to Analysis

Impacts on library services are considered significant if an increase in population or development levels would result in an increased demand for library services that would require the need for new or physically altered library facilities in order to maintain acceptable levels of service, the construction of which could result in substantial adverse environmental effects. Additionally, the Proposed Project's potential contribution to cumulative library impacts is evaluated.

Project Impacts

Construction Impacts

Impact PS-13: Project construction would not result in adverse physical impacts or in the need to construct new or physically altered facilities in order to maintain acceptable service objectives for library services. (No Impact)

Construction of the Proposed Project would not result in impacts on the San Francisco Public Library system, as the construction itself would not result in an increase in population requiring library services. No library branches are located on the Islands. All existing library services in San Francisco would continue to be available to existing Island residents throughout the duration of project construction, as under current conditions. Construction would not prevent access to existing libraries located off-site, as access would be maintained through compliance with the Construction Traffic Management Plan prepared for the Project, as required by Mitigation Measure M-TR-1, discussed in Section IV.E, Transportation, p. IV.E.69. Compliance with the CTMP would ensure that access on and off the Islands is not obstructed during construction activities. Thus, there would be no construction-related impacts to libraries and no mitigation is required.

Operational Impacts

Impact PS-14: Implementation of the Proposed Project would not increase demand for library services to a level that would result in the need to construct new library facilities in order to maintain acceptable levels of service, or other performance objectives of the San Francisco Public Library system. (*Less than Significant*)

Residential and nonresidential development associated with the Proposed Project would increase demand for local library services within the Development Plan Area. The Proposed Project would result in a total of about 18,640 future residents. ABAG's Projections 2007 estimates that the City will gain about 113,900 persons between 2010 and 2030. Though population increase on the Islands would be substantial from a localized perspective, population growth due to implementation of the Proposed Project would represent about 16 percent of Citywide population growth (113,900 persons) expected by 2030. The residential population expected on the Islands in 2030, about 18,640, would represent about 2 percent of the expected San Francisco population in 2030, which would be 922,600. (See Section IV.C, Population and Housing.) Although the Proposed Project would result in a population increase within the Development Plan Area, existing library branches, including the new Mission Bay branch (opened in 2009), the North Beach branch soon to be reconstructed, and the Main Library, would meet the demand for library services generated by the Proposed Project, and would not require construction of new or expanded library facilities beyond those already proposed or under construction under the Branch Library Improvement Program.

Thus, the new, existing, and rebuilt SFPL branches would accommodate increased demand from the Proposed Project, and no additional library facilities would be required. Impacts on library services would be less than significant, and no mitigation is required.

Cumulative Impacts

Impact PS-15: The Proposed Project's cumulative contribution would not increase demand for library services that would result in the need to construct new library facilities in order to maintain acceptable levels of service, performance objectives, or need to construct new or physically altered facilities in order to maintain acceptable service objectives. (*No Impact*)

The geographic context for the analysis of cumulative impacts associated with libraries is the City and County of San Francisco. The existing library services in the City are described in the Setting section, p. IV.L.33, representing the baseline conditions for evaluation of cumulative impacts. Reasonably foreseeable future development forecasts are based on projections of future growth and take into account projects going through the entitlement process. The City of San Francisco provides public services within the City's boundaries. The BLIP, launched as a result of a 2000 bond measure, included plans for construction of eight new library branches. The BLIP

includes completion of a Community Needs Assessment for each branch, with public meetings, community surveys, and outreach to neighborhood organizations. Most branch libraries in the City are currently being renovated, or are planned for future renovation, under the BLIP program. As stated in the SFPL Strategic Plan, there is no City standard for library service and each branch library must evaluate how it may best meet the needs of the community. To this end, the SFPL has developed the Strategic Plan, which provides every library facility and program with a unifying organizational vision and systemwide goals.

The two projects expected to occur in the vicinity of the Proposed Project, the Ramps Project and the expanded 400-slip marina at Clipper Cove, would not have a substantial impact on the public services in the vicinity. Therefore, there would be no significant cumulative impacts on libraries as a result of these projects.

Reasonably foreseeable future development projects within the City, including growth in the southeast and southwest quadrants at Hunters Point/Candlestick Point and at Parkmerced, would increase the City's resident population in 2030 to 922,600,⁴⁶ of which the Proposed Project would constitute 2 percent, resulting in increased demand on public library resources. All cumulative projects would be expected to be considered during development of renovation planning for individual branches. Therefore, it is not anticipated that the Proposed Project would have considerable cumulative impacts on the demand for library services that would require construction of new or expanded library facilities beyond those already proposed or under construction under the Branch Library Improvement Program. The Proposed Project would not result in a significant cumulative impact to library service, and no mitigation would be required.

⁴⁶ The basis for population projections is discussed in Section IV.C, Population and Housing, p. IV.C.2.

M. BIOLOGICAL RESOURCES

This section describes the biological resources that occur or have the potential to occur on the Proposed Project site or in the vicinity, and evaluates the possible Project-related impacts on these resources. Mitigation measures to reduce adverse impacts on biological resources to less-than-significant levels are identified.

Information on existing vegetation and wildlife communities and special-status species was obtained from regional plans and reports, including the *Final Environmental Impact Report for the Transfer and Reuse of Naval Station Treasure Island*,¹ records from the California Natural Diversity Database² and California Native Plant Society (“CNPS”) Electronic Inventory,³ reconnaissance-level field surveys, and other biological literature.

In addition, this section incorporates information from a proposed Habitat Management Plan (“HMP”) for Yerba Buena Island. In the Development Plan endorsed by the Treasure Island Development Authority (“TIDA”) in October 2006 and by the San Francisco Board of Supervisors in December 2006, the Board added the requirement that “a management plan for the natural areas on Yerba Buena Island shall be developed and adopted” as a condition of the Board’s approval of the final Disposition and Development Agreement (“DDA”). The draft HMP was released for public comment on December 21, 2009. Implementation actions pursuant to the final HMP are being considered and analyzed in this EIR as part of the Proposed Project.⁴

SETTING

Former Naval Station Treasure Island included all of the land on Treasure Island, consisting of level, filled land; about 94 acres of the land on Yerba Buena Island, a natural island; and approximately 540 acres of tidal and submerged lands adjacent to the Islands. The CEQA baseline for biological resources analysis thus comprises an area that, as a former functioning military base, has historically been heavily used. Such use has reduced and degraded the Island’s natural habitat, except for the portions of San Francisco Bay immediately offshore and scattered relict stands of natural vegetation on Yerba Buena Island.

¹ San Francisco Planning Department. 2005. *Transfer and Reuse of Naval Station Treasure Island; Final Environmental Impact Report*. State Clearinghouse No. 1996092073.

² CNDDDB, 2009. California Natural Diversity Data Base, Rarefind 3 computer program, Sacramento, CA.

³ CNPS, 2009. Inventory of Rare and Endangered Plants, 2009. Version 6-05c. (Hereinafter “CNPS 2009.”) <http://cnps.web.aplus.net/cgi-bin/inv/inventory.cgi>.

⁴ The draft HMP is available on the web at <http://www.sftreasureisland.org/Modules/ShowDocument.aspx?documentid=459>.

REGIONAL SETTING

The Project Area (project site) is located in the Bay Area-Delta Bioregion, as defined by the State's Natural Communities Conservation Program. This bioregion consists of a variety of natural communities that range from the open waters of the Bay and Delta to salt and brackish marshes to chaparral and oak woodlands. The temperate climate is Mediterranean in nature, with relatively mild, wet winters and warm, dry summers. The high diversity of vegetation and wildlife found in the region is a result of soils, topographic, and micro-climate diversity that promotes relatively high levels of endemism.⁵ This, in combination with the rapid pace of development in the region, has resulted in a relatively high degree of endangerment for local flora and fauna.

- The San Francisco Bay-Delta is the second largest estuary in the United States and supports numerous aquatic habitats and biological communities. The estuary's populations of fish and wildlife have changed markedly in the past 150 years, with losses due to over-harvest, habitat loss and degradation, introduced species, pollutants, and the modification of freshwater flows. It encompasses 479 square miles, including shallow mudflats. San Francisco Bay is divided into four main basins: South Bay, Central Bay, San Pablo or North Bay, and Suisun Bay. This assessment focuses on the Central Bay, which is located between the San Francisco-Oakland Bay Bridge ("Bay Bridge") and the Richmond-San Rafael Bridge and connects to the Pacific Ocean through the Golden Gate. The regional setting for purposes of this evaluation includes both the shallow water habitats around San Francisco Bay – the "baylands"⁶ and the waters of the Bay itself.

The Central Bay subregion of the baylands includes the main body of San Francisco Bay. Its major streams, all relatively small, include Codornices, Corte Madera, Temescal, and Wildcat Creeks. Lands within this subregion are in Alameda, Contra Costa, Marin, San Francisco, and San Mateo Counties. Together, there are about 33,000 acres of baylands in the Central Bay subregion.

⁵ *Endemism* refers to the degree to which organisms or taxa are restricted to a geographical region or locality and are thus individually characterized as endemic to that area.

⁶ Goals Project. 1999. *Baylands Ecosystem Habitat Goals*. A report of habitat recommendations prepared by the San Francisco Bay Area Wetlands Ecosystem Goals Project. U.S. Environmental Protection Agency, San Francisco, Calif./S.F. Bay Regional Water Quality Control Board, Oakland, California.

IV. Environmental Setting and Impacts
M. Biological Resources

The Central Bay contains the deepest areas of the Bay-Estuary and the most natural and man-made hard bottom substrate.⁷ Beneath the Golden Gate the seafloor reaches depths of 361 feet with strong tidal currents running through the Golden Gate and throughout the Central Bay.⁸ These strong tidal flows maintain deeper water depths, despite the large volume of sediment that has historically moved through the Bay from the Delta and local streams. Because of its close proximity to the Golden Gate and open ocean waters, Central Bay biota most closely resembles

⁷ NOAA. 2007. *Report on the Subtidal Habitats and Associated Biological Taxa in San Francisco Bay*. Prepared by NOAA National Marine Fisheries Service. Santa Rosa, CA. June 2007. 86 pages.

⁸ NOAA. 2007. *ibid.*

open coast plant, invertebrate, and vertebrate marine communities which shift to estuarine communities farther upstream, into the estuary.

The fish population of the Central Bay is characterized by sharks, such as the brown smoothhound (*Mustelus henlei*) and leopard (*Triakis semifaciata*), brown rockfish (*Sebastes auriculatus*), plainfin midshipmen (*Porichthys notatus*), and flatfish such as the California halibut (*Paralichthys californicus*) and the speckled sanddab (*Citharichthys stigmaeus*). In addition, bat rays (*Myliobitus californica*), skates (*Raja binoculata*), northern anchovy (*Engraulis mordax*), bay pipefish (*Synnathus leptorhynchus*), assorted gobys, perch, and croakers are present. Two species of shrimp (*Crangon nigromaculata* and *Lissocrangon stylirostris*) and four species of crabs (*Cancer gracilis*, *C. productus*, *C. antennarius*, and *Metacarcinus magister*) are widely distributed.⁹

Under the Pacific Coast Salmon Fishery Management Plan, the entire San Francisco Bay-Delta Estuary has been designated as Essential Fish Habitat (“EFH”) (see “Regulatory Framework,” pp. IV.M.35–IV.M.36, for an explanation of EFH) for spring-, fall-, late fall- and winter-run Central Valley Chinook salmon (Pacific salmon).¹⁰ These areas serve as a migratory corridor, holding area and rearing habitat for both adult and juvenile salmon. Likewise, the *Pacific Pelagic Fishery Management Plan* identifies the San Francisco Bay-Delta as EFH for fish managed under their program, including Pacific herring, northern anchovy, and Pacific sardine.¹¹

The San Francisco Bay-Delta is an important wintering and stop-over site for the Pacific Flyway. More than 300,000 wintering waterfowl use the region and associated ponds.¹² Bird guilds that use the open waters of San Francisco Bay-Delta include the diving birds, which feed in deeper water on benthic invertebrates; dabblers, which feed in the upper water column of shallow subtidal areas; piscivores, which feed on fish; and opportunistic predators.¹³ The dominant marine birds regularly inhabiting or utilizing the Central Bay include cormorants (*Phalacrocorax* spp.), pigeon guillemot (*Cephus columba*), herring gull (*Larus argentatus*), mew gull (*L. canus*) and California brown pelican (*Pelecanus occidentalis californicus*). Among the diving benthivores guild, canvasback (*Aythya valisineria*), greater scaup (*A. marila*), lesser scaup (*A. affinis*), and surf scoter (*Melanitta perspicillata*) are the most common.

Seven species of marine mammals occur within the San Francisco Bay-Delta. The harbor seal (*Phoca vitulina*), California sea lion (*Zalophus californianus*), harbor porpoise (*Phocoena phocoena*), and gray whale (*Eschrichtius robustus*) are the most common species that use the

⁹ NOAA. 2007. *op. cit.*

¹⁰ PMFC. 2003. Pacific Coast Salmon Plan. Portland, OR. <http://www.pcouncil.org>.

¹¹ PMFC. 1998. The Coastal Pelagic Species Fishery Management Plan. Portland, OR. <http://www.pcouncil.org>.

¹² NOAA. 2007. *op. cit.*

¹³ NOAA. 2007. *op. cit.*

open waters of the Bay-Delta for migrating, foraging, and resting.¹⁴ While these species typically concentrate their activities in the Central Bay and adjacent portions of the South Bay and North Bay, some harbor seals, harbor porpoise, and California sea lions travel throughout the Bay-Delta and up into the Sacramento River in search of salmon and other forage. Harbor seals are the only year-round residents of the Bay-Delta, with colonies located at Yerba Buena Island (see “Special Status Wildlife,” p. IV.M.21).

PROJECT SITE SETTING

Treasure Island

Treasure Island is a flat, engineered island composed of artificial fill. Habitat types on Treasure Island are landscaped areas and developed areas, and neither area represents a defined vegetation or wildlife habitat type. Landscaped areas include mature ornamental trees, shrubs, and grasses. Much of the vegetation found on Treasure Island consists of introduced species, such as blue gum eucalyptus (*Eucalyptus globulus*), Monterey pine (*Pinus radiata*), and Monterey cypress (*Cupressus macrocarpa*). Native plant species are not likely to be found in landscaped areas due to frequent disturbance, human control, and lack of proper soils. For these reasons, this habitat type is of low value to wildlife.¹⁵

Yerba Buena Island

Yerba Buena Island, a natural feature in the Central Bay, is markedly different from Treasure Island. It is approximately 150 acres in size. Historically, topography was broadly sloping from Yerba Buena Island’s summit about 350 feet above mean sea level, becoming steeper further from the summit. Current topography includes a series of terraces engineered for development beginning at the top of the island, with steep slopes and cliffs down to the Bay on all sides. Slopes on Yerba Buena Island range from less than 5 up to 75 percent. The following discussion of biological resources applies generally to Yerba Buena Island, except where indicated. Figure IV.M.1: Vegetation Communities on Yerba Buena Island, shows a map of the vegetation types on the island.

Vegetation Communities

California Annual Grassland

The California annual grassland community is dominated by annual non-native grasses and herbaceous annuals and generally corresponds to areas that have been disturbed by human activities. On Yerba Buena Island, this plant community lacks a significant tree or shrub layer and is dominated by brome grasses, Italian ryegrass, and wild oats (see Appendix H for a

¹⁴ NOAA. 2007. *op. cit.*

¹⁵ San Francisco Planning Department. 2005. *op. cit.*, Section 3.8, Biological Resources, and specifically pp. 3-94.

- THIS PAGE INTENTIONALLY LEFT BLANK



SOURCE: GlobeXplorer, 2006; ESA, 2010; Wood, 2008

FIGURE IV.M.1: VEGETATION COMMUNITIES ON YERBA BUENA ISLAND

checklist of plant species identified as occurring on Yerba Buena Island, including common and scientific names). Several areas dominated by California annual grassland on the U.S. Coast Guard lands support dune gilia (*Gilia capitata* ssp. *chamissonis*) and cobwebby thistle (*Cirsium occidentale* var. *occidentale*), two plants of local importance for conservation. This plant community covers only a small area on the island (approximately 1.8 acres). Originally, much of the island would appear to have been covered by coastal prairie, but this community has been extirpated over time as a result of grazing, development, grading, and tree planting.

Valley Wildrye Grassland

Although their total cover is not large (approximately 1.42 acres), wildrye grasses are common on Yerba Buena Island, especially creeping wildrye (*Leymus triticoides*). These are native, perennial grasses that spread by creeping rhizomes (underground stems). Few areas are dominated by these grasses – they are usually a minor component of a woodland understory – however, there are three areas where wildrye grasses are dominant and there is a rapidly spreading fourth stand near the north end of Clipper Cove beach.

Central Coast Riparian Scrub

There are approximately 5.5 acres of central coast riparian scrub vegetation on Yerba Buena Island. This community is dominated by arroyo willow, which, in most cases, is growing in dense, impenetrable thickets, often at the base of steep slopes. The establishment of this community in many areas seems to be associated with natural seeps and/or artificial irrigation from leaky pipes. These areas generally have relatively low plant species diversity, and some stands are being invaded by Himalayan blackberry (*Rubus armeniacus*) and sticky eupatorium (*Ageratina adenophora*) or encroached by eucalyptus.

Northern Coastal Scrub

The northern coastal (*Franciscan*) scrub vegetation community is dominated by small- to medium-sized shrubs, such as California sagebrush (*Artemisia californica*), coyote brush (*Baccharis pilularis*), sticky monkey flower (*Diplacus aurantiacus*), lizard tail (*Saururus cernuus*), and yellow bush lupine (*Lupinus arboreus*), and occurs in relatively undisturbed areas along the steep bluffs of Yerba Buena Island. Much of the 14.3 acres of northern coastal scrub on Yerba Buena Island is relatively undisturbed and has a high diversity of native plant species. This community also supports populations of the special-status dune gilia (*Gilia capitata*).

California Buckeye Woodland

California buckeye (*Aesculus californica*) is a native tree species that occurs throughout the State in a wide variety of habitats but is considered locally rare in San Francisco.¹⁶ There is only one

¹⁶ CNPS. 2009. *op. cit.*

stand of vegetation dominated by this tree on Yerba Buena Island and it is relatively small (approximately 0.2 acre), with a lawn understory. However, the trees are mature and represent a historic remnant of the vegetation that most likely existed on Yerba Buena Island prior to human disturbance.

Coast Live Oak Woodland

Coast live oak (*Quercus agrifolia*) trees are present across Yerba Buena Island and are the dominant native tree. Aspect, slope, density, age, and associated species differ greatly from one stand of coast live oak woodland to another. Some stands have a healthy understory of toyon (*Heteromeles arbutifolia*), California hazelnut (*Corylus cornuta* var. *californica*), blue elderberry (*Sambucus mexicana*), and Dutchman's pipevine (*Aristolochia tomentosa*), while other stands are being invaded by non-native species like French broom (*Genista monspessulana*), Algerian and English ivy (*Hedera helix* ssp. *canariensis* and *Hedera helix*), or are encroached upon by eucalyptus trees. One unique stand of coast live oak woodland is a "pygmy" (i.e., structurally smaller than typical for the age of the stand) grove that has developed in response to environmental factors like strong wind and poor soils. Coast live oak woodland covers approximately 7.5 acres on Yerba Buena Island.

Coast Live Oak Woodland/Eucalyptus

The 19.5 acres of coast live oak woodland/eucalyptus support a co-dominance of coast live oak and eucalyptus trees. The two species form a mosaic distributed throughout this vegetation type. Distinguishing this community from eucalyptus woodland is important, and recognized in the HMP, since there may be a greater potential to implement habitat restoration or enhancement within the mixed woodland (by removing eucalyptus trees and enhancing the existing oak woodland) rather than within the woodland dominated by eucalyptus.

Eucalyptus Woodland

Non-native eucalyptus trees were planted on Yerba Buena Island beginning in the early 1900s. The trees are now very large and dominate approximately 31 acres of the island's vegetation, but their density within mapped stands is variable. The understory in these areas varies greatly from being completely dominated by non-native species like French broom and iceplant (*Mesembryanthemum crystallinum*) to stands where the special-status plant dune gilia is present.

Ruderal/Landscaped

Ruderal and landscaped areas are sites where the natural vegetation has been significantly altered by human activity. These are areas that have either been landscaped or impacted by road construction, development, or other significant disturbance. Existing vegetation in these areas is generally composed of exclusively non-native, and often invasive, plants. Common invasive

non-native plants found on Yerba Buena Island include common periwinkle, French broom, fennel (*Foeniculum vulgare*), and Algerian ivy. This vegetation type occurs on both Treasure Island, where it completely dominates, and on Yerba Buena Island.

Intertidal and Nearshore Subtidal Zones

Intertidal Habitat

The intertidal regions of the Islands contain highly diverse and varied habitats dominated by rocky substrates that support an abundance of marine flora and fauna. The Islands' proximity to the Golden Gate and the Pacific Ocean has resulted in an intertidal zone inhabited by many coastal as well as estuarine species. The natural bluff and exposed rocky shoreline of Yerba Buena Island, which are interspersed with sandy pocket beaches, provide a different assortment of ecological niches than the quarried riprap rock along Treasure Island's shoreline. The angular and piled rocks provide additional habitat for a more diverse invertebrate community because of increased and protected surface area created by the piled rocks. These provide numerous protected havens in which assorted marine species are able to survive and flourish, including the native California oyster (*Ostreola conchaphila*).¹⁷ This previously presumed extinct species is making a substantial recovery throughout the Bay and has established a multi-year residency in the lower rocky intertidal areas.

The intertidal regions of the Islands support numerous marine and estuarine species of red and green algae, bryozoa, sponges, ectoprocts, barnacles, mussels, chitons, crabs, and anemones. The taxonomic list includes both native and non-native species.¹⁸ As illustrated by the presence of both the hybridized bay mussel (*Mytilus trossulus/galloprovincialis*) along the southern and eastern shoreline of Treasure Island and the coastal mussel (*M. californianus*) predominating along the western and northern shoreline, there is a shift in intertidal flora and fauna from the more exposed and higher energy western side of the island to the more protected eastern side of the island. Eelgrass (*Zostera marina*) beds occur in the near subtidal areas along the northeast and east sides of Treasure Island as well as in Clipper Cove, adjacent to the northeast shore of Yerba Buena Island. One eelgrass bed extends along nearly the entire eastern shore of Treasure Island.^{19,20,21}

¹⁷ Applied Marine Sciences, Inc., (AMS) *Survey of Intertidal Habitat and Marine Biota at Treasure Island and Along the Western Shoreline of Yerba Buena Island*. Report prepared for the Treasure Island Redevelopment Project, San Francisco, CA, April 2009 (hereinafter "AMS 2009a").

¹⁸ AMS. 2009a.

¹⁹ AMS. 2009a.

²⁰ Merkel & Associates. 2004. *Baywide Eelgrass Inventory of San Francisco Bay*. Prepared for California Department of Transportation in Cooperation with NOAA Fisheries. October 2004.

²¹ Merkel & Associates. *Eelgrass Habitat Surveys for the Emeryville Flats and Clipper Cove, Yerba Buena Island*. October 1999-2005, and 2007. Prepared for the California Department of Transportation. January 2008.

Submerged aquatic vegetation (“SAV”) attached to the rocky intertidal and subtidal habitat surrounding both islands, especially eelgrass beds, are considered “habitat forming” species that create unique biological environments for spawning Pacific herring, serve as nursery grounds for many important Bay fish and invertebrate species including shrimp (*Palaemonetus paludosus*) and Dungeness crabs (*Metacarcinus magister*), and provide important foraging areas for black brandt (*Branta bernicla nigricans*).²²

Subtidal Habitat

The nearshore subtidal region surrounding Treasure Island can be characterized as soft mud and sand with occasional rocks and cobbles that have become dislodged from the armored shoreline.^{23,24,25} The soft substrate habitats surrounding the Islands contain mixtures of fine to medium sand close inshore in the higher wave energy areas, shifting to sandy silts,²⁶ and then becoming sandier again in the navigation channels. The sandy substrate invertebrate species are characterized by the polychaetes *Mediomastus* spp. and *Sphaerosyllis californiensis*, several low abundance amphipod species (*Ampelisca abdita*, *Corophiumm acherusicum*, *C. heteroceratun*, and *C. insidiosum*), cumaceans, and the low occurrence mollusk, *Musculista senhousia*. The muddy-sand benthic community had a more diverse polychaete community represented by several subsurface deposit feeders, the tube dwelling filter-feeding species *Euchonia limnicola*, and the carnivorous species *Exogone lourei*. In most of the Central Bay soft-substrate benthic habitat, the cnidarian, *Stylatula elongata* and several surface deposit feeders, such as *Ameana* spp., are present throughout the year.

Applied Marine Sciences (“AMS”),²⁷ in assessing benthic habitat conditions and associated species composition in the vicinity of the proposed Ferry Terminal, reported the presence of two separate benthic infaunal communities inhabiting the study site with a sandier sediment located closest to shore and a sandy-mud substrate farther offshore. The shallower sandy benthic community was dominated by the bivalve *Rochefortia coani*, the polychaetes, *Ameana occidentalis* and *Mediomastus* spp., the cnidarian, *Stylatula elongata*, and the amphipod, *Ampelisca abdita*. The sandy-mud community was dominated by the polychaetes *Mediomastus* spp., *Euchonia limnicola*, and *Ameana occidentalis* along with the amphipod, *A. abdita*, and the cnidarian, *S. elongata*. Two more polychaetes, *Spiophanes duplex* and *Dorvillea longicornis*, and

²² Merkel & Associates. 2005. Eelgrass Community Pilot Study for San Francisco Bay: Techniques for examining invertebrates and fish assemblages within multiple eelgrass beds. Document EA-012041; San Francisco-Oakland Bay Bridge East Span Seismic Safety Project. Prepared for the California Department of Transportation in Cooperation with NOAA Fisheries. October 2005.

²³ AMS. 2009a. *op.cit.*

²⁴ Applied Marine Science, *Benthic Survey of Proposed Treasure Island, California Redevelopment Ferry Terminal Location*. Report prepared for the Treasure Island Redevelopment Project, San Francisco, CA, May 2009. (hereinafter “AMS 2009b.”)

²⁵ NOAA. 2007. *op.cit.*

²⁶ AMS. 2009b. *op. cit.*

²⁷ AMS. 2009b. *op. cit.*

the mollusk, *R. coani* collectively represented the eight most dominant taxa in this community. Unlike the more diverse dominant infaunal community inhabiting the coarser sediments inshore, the sandy-mud community was dominated by polychaetes.

Based on sediment composition, it appears that the habitat occupied by the first benthic community is subject to regular wave action or strong tidal currents that prevent the deposition of fine sediments or subject them to resuspension and removal. The habitat occupied by the second benthic community appears to be less subject to physical disturbance from wave action or tidal currents, possibly because of the slightly deeper water.²⁸

The most common large mobile invertebrate organisms in the Central Bay include blackspotted shrimp (*Crangon nigromaculata*), California smooth shrimp (*Lissocrangon stylirostris*), Dungeness crab (*Metacarcinus magister*), and the slender rock crab (*Cancer gracilis*). Although other species of shrimp are present in the Central Bay, their numbers are substantially lower when compared to the number of smooth bay and blackspotted shrimps present.^{29,30} All of these mobile invertebrates are present throughout the Central Bay and provide an important food source for carnivorous fishes, marine mammals, and birds in San Francisco Bay's food web. Dungeness crab use most of the Bay as an area for juvenile growth and development prior to returning to the ocean as sexually mature adults.³¹

The bottom, or demersal, fish community reported to inhabit the area surrounding Treasure Island comprises more than 45 species. The bay goby (*Lepidogobius lepidus*), speckled sanddab (*Citharichthys stigmaeus*), English sole (*Parophrys vetulus*), plainfin midshipman (*Porichthys notatus*), Pacific staghorn sculpin (*Leptocottus armatus*), shiner perch (*Cymatogaster aggregata*), white croaker (*Genyonemus lineatus*), longfin smelt (*Spirinchus thaleichthys*), cheekspot goby (*Ilypnus gilberti*), and brown rockfish (*Sebastes auriculatus*) are the dominant taxa of this community, accounting for approximately 96 percent of the fish present (see Table IV.M.1).

²⁸ AMS. 2009b. *op. cit.*

²⁹ NOAA. 2007. *op. cit.*

³⁰ Baxter *et al.* 1999. Baxter, R., K. Hieb, S. DeLeon, K. Fleming, and J. Orsi. 1999. Pleuronectiformes. In: Orsi, James J. editor, Report on the 1980-1995 Fish, Shrimp, and Crab Sampling in the San Francisco Estuary, California, pp. 77-133. Prepared by The Interagency Ecological Program for the Sacramento-San Joaquin Estuary.

³¹ Tasto, R. N. 1979. "San Francisco Bay: Critical to the Dungeness Crab?" In: T. J. Conomos, editor, *San Francisco Bay: The Urbanized Estuary*. Pacific Div Am Ass Adv Sci, San Francisco, California: 479-490.

IV. Environmental Setting and Impacts
M. Biological Resources

Subtidal plants and SAV occur throughout the Central Bay on both soft and hard substrate. On the shallow unconsolidated subtidal habitat within the Central Bay, such as in Clipper Cove and along the intertidal mudflats surrounding Treasure Island, the green algae, *Ulva/Enteromorpha*, *Gracillaria verrucosa* (formerly *pacifica*), *Ruppia maritime*, *Potamogeton pectinatus* and *Zostera*

● **Table IV.M.1: Benthic Fish Community Composition and Abundance Indices for Combined Shallow and Deep Water Sites near Treasure Island,¹ Based on Otter Trawl Data, 2000–2008 (fish per hectare)**

Species ²	Common Name	2000	2001	2002	2003	2004	2005	2006	2007	2008	Mean	% Comp.
<i>Lepidogobius lepidus</i>	bay goby	634	797	213	97	326	155	996	272	429	435	29.1%
<i>Citharichthys stigmaeus</i>	speckled sanddab	801	334	253	107	86	171	174	471	567	329	22.0%
<i>Parophrys vetulus</i>	English sole	182	400	221	84	31	254	516	179	98	217	14.5%
<i>Porichthys notatus</i>	plainfin midshipman	263	95	258	110	238	335	357	96	166	213	14.2%
<i>Leptocottus armatus</i>	Pacific staghorn sculpin	204	87	50	13	10	69	138	47	155	86	5.7%
<i>Cymatogaster aggregata</i>	shiner perch	122	70	92	78	44	80	46	38	66	71	4.7%
<i>Genyonemus lineatus</i>	white croaker	31	26	30	12	9	17	3	95	45	30	2.0%
<i>Spirinchus thaleichthys</i>	longfin smelt	50	19	5	19	18	8	23	34	4	20	1.3%
<i>Ilypnus gilberti</i>	cheekspot goby	20	11	13	23	31	42	19	9	6	19	1.3%
<i>Sebastes auriculatus</i>	brown rockfish	54	60	38	12	1	0	0	4	0	19	1.3%
<i>Microgadus proximus</i>	Pacific tomcod	14	23	41	24	2	0	2	6	3	13	0.8%
<i>Syngnathus leptorhynchus</i>	bay pipefish	9	3	8	5	3	3	16	3	14	7	0.5%
<i>Tridentiger trigonocephalus</i>	chameleon goby	2	0	0	2	1	19	29	2	0	6	0.4%
<i>Citharichthys sordidus</i>	Pacific sandab	1	1	0	13	16	8	0	1	0	4	0.3%
<i>Clupea pallasii</i>	Pacific herring	3	10	2	4	0	2	5	2	1	3	0.2%
<i>Pholis ornate</i>	saddleback gunnel	5	6	2	1	0	4	11	1	0	3	0.2
<i>Artedius notospilotus</i>	bonyhead sculpin	5	3	3	4	1	6	5	1	1	3	0.2%

(continued)

● **Table IV.M.1 (continued)**

Species ²	Common Name	2000	2001	2002	2003	2004	2005	2006	2007	2008	Mean	% Comp.
<i>Symphurus atricaudus</i>	California tonguefish	1	0	1	15	0	9	1	1	0	3	0.2%
<i>Paralichthys californicus</i>	California halibut	1	1	1	5	6	5	2	3	3	3	0.2%
<i>Iparis pulchellus</i>	showy snailfish	4	0	1	0	0	0	7	8	0	2	0.2%
<i>Mustelus henlei</i>	brown smoothhound	4	1	1	2	2	1	1	2	1	2	0.1%

Notes:

¹ CDFG/IEP trawl data, Stations 109, 110, 211, 212, and 214.

² Additional fish species that occurred in trawls at less than significant numbers include: walleye surfperch, big skate, yellowfin goby, white seaperch, starry flounder, lingcod, black perch, sand sole, pygmy poacher, Pacific sardine, leopard shark, whitebait smelt, topsmelt, American shad, unidentified rockfish, yellowtail rockfish, diamond turbot, curlfin sole, buffalo sculpin, barred surfperch, slipskin snailfish, hornyhead turbot, vermilion rockfish, arrow goby, bat ray, snake prickleback, hybrid sole, wakasagi, Pacific lamprey, river lamprey, rubberlip seaperch, kelp greenling, unidentified snailfish, pile perch, dwarf perch, threadfin shad, spiny dogfish, night smelt, spotfin surfperch, striped bass, bocaccio, Pacific pompano, thornback, brown Irish lord, green sturgeon, shimofuri goby.

Source: CDFG 2000–2008. Unpublished data of California Department of Fish and Game (CDFG Interagency Ecological Program for San Francisco Estuary. Monthly Mid-water and Otter-Trawl Survey Data for San Francisco Estuary. Available by contacting DCFG at khieb@dfg.ca.gov).

marina (eelgrass) frequently occur.³² *Zostera*, is a shallow subtidal as well as intertidal flowering plant found inhabiting bays, estuaries, and the leeside of islands, such as Treasure, Angel, Yerba Buena, and Alcatraz Islands.³³ Bed locations and size are determined by water depth and turbidity. Eelgrass can only become established in those areas of the Bay-Delta where water depth and turbidity allow light to penetrate to the seafloor.³⁴ The extensive eelgrass bed located along the eastern shore of Treasure Island extends almost the entire length of the island and begins at the lower edge of the low intertidal zone and extends offshore approximately 30 feet

³² NOAA. 2007. *op. cit.*

³³ Merkel & Associates. 2004. *op. cit.*

³⁴ Merkel & Associates. 2004. *ibid.*

from the island.³⁵ A second eelgrass bed is located to the north of the Island³⁶ and a third in Clipper Cove, adjacent to the northeast shore of Yerba Buena Island.

Several studies have demonstrated that fauna in eelgrass beds is enhanced in numbers, species, and standing crop compared to unvegetated soft bottom habitat.³⁷ Eelgrass abundance and density is dynamic and fluctuates from year to year as a result of fluctuating physical conditions including, but not limited to, high freshwater and sediment discharge from the Delta and Bay watersheds, increased turbidity, extensive and violent storms, and water temperatures.

Submerged Aquatic Vegetation

SAV beds and plants are primary spawning habitat for many invertebrate and vertebrate species in San Francisco Bay, most notably, Pacific herring.³⁸

In addition to eelgrass beds discussed above, additional species of red and brown algae are found throughout the Central Bay and along the shorelines of the Islands because of the strong ocean influence through the Golden Gate. These include *Cladophora sericea*, *Codium fragile*, *Fucus gardneri*, *Laminaria sinclairii*, *Egregia*, *Halkymenia schizymenioides menziesii*, *Sargassum muticum*, *Polyneura latissima*, *Cryptopleura violacea*, and *Gelidium coulteri*.³⁹ In addition, the species *Codium fragile* subspecies *tomentosoides*, *Bryopsis hypnoides*, *Chondracanthus* (formerly *Gigartina*) *exaspartata*, *Ahnfeltiopsis* (formerly *Gymnogongrus*) *leptophyllus* can be found inhabiting either hard or soft substrate.⁴⁰ Many of these species are present attached to submerged rocks and the lower rocky intertidal areas around both of the islands.⁴¹ All submerged aquatic vegetation in the Central Bay is considered critical essential fish spawning habitat⁴² for Pacific herring (see “Regulatory Framework,” pp. IV.M.35–IV.M.36).

Open Water Habitat

Because of its close proximity to the Pacific Ocean, the open water environment of the Central Bay in and around the Islands is most like the open water coastal environment. Because of its lack of significant freshwater inflow, the phytoplankton and zooplankton communities are almost entirely marine in composition and seasonality. The copepods *Acartia clausi*, *A. californiensis*, *Oithona davisae*, harpacticoid copepods, tintinnids, and the larvae of gastropods, bivalves,

³⁵ AMS. 2009a. *op. cit.*

³⁶ NOAA. 2007. *op. cit.*

³⁷ NOAA. 2007. *ibid.*

³⁸ NOAA, 2007. *ibid.*

³⁹ NOAA, 2007. *op. cit.*

⁴⁰ NOAA, 2007. *ibid.*

⁴¹ AMS, 2009a. *op. cit.*

⁴² The Magnuson-Stevens Act defines “essential fish habitat” as those waters and substrate necessary to fish for spawning, breeding, feeding, or growth to maturity.

barnacles, and polychaetes dominate the community structure.⁴³ Mean zooplankton biomass has ranged from 10–50 milligrams of carbon per cubic centimeter for the Bay with the mean values occurring in the Central Bay.⁴⁴ The waters of San Francisco Bay, including those surrounding Treasure Island, are typically characterized as being turbid because of local watershed runoff, inflow from the Sacramento and San Joaquin Rivers, and constant resuspension of bottom sediments from tidal and wind action.⁴⁵ As a result, light penetration is greatly affected by turbidity levels and as a result is generally limited to the upper meter of water.⁴⁶ As a consequence, plankton abundance and productivity is typically lower than nearby coastal waters and less turbid estuaries and embayments. Unlike the North and South Bays, the Central Bay is the least affected by introduced exotic species.⁴⁷

Central Bay meroplankton, including macrozooplankton and micronekton, is dominated by the ctenophore (*Pleruobranchia bachei*), the isopod (*Syndotea laticauda*), the shrimps (*Palaemon macrodactylus*, *Crangon franciscorum*, and *C. nigricauda*), the mysid (*Neomysis kadiakensis*), and the medusa (*Polyorchis* spp).⁴⁸ Those meroplankton taxa that are found year-round throughout the Central Bay include two of the shrimp species (*Crangon franciscorum* and *C. nigricauda*) and northern anchovy.⁴⁹

Of the 47 fish species known to utilize Central Bay pelagic (water column) waters, 37 were observed inhabiting the waters immediately around the Islands.⁵⁰ Four of these 37 species account for more than 98 percent of the total abundance of fish regularly encountered in both deep channel and shallow margins areas. Of the four dominant species, northern anchovy (*Engraulis mordax*) is the most common species observed. It is joined by Pacific herring (*Clupea pallasii*), jacksmelt (*Atherinopsis californiensis*), and shiner perch (*Cymatogaster aggregata*) as the species that dominate the pelagic fish community around the Islands (Table IV.M.2).

⁴³ Ambler, J. W., J. E. Cloern and A. Hutchinson. 1985. *Seasonal Cycles of Zooplankton from San Francisco Bay*. *Hydrobiologia* 129:177-197.

⁴⁴ Ambler. 1985. *ibid.*

⁴⁵ NOAA. 2007. *Ibid.*

⁴⁶ May, C. L., J. R. Kosefi, L. V. Luca, J. E. Cloern, and D. H. Schoellhamer. 2003. Effects of spatial and temporal variability of turbidity on phytoplankton blooms. *Mar. Ecol. Prog. Ser* 254: 111.128.

⁴⁷ Ambler. 1985. *ibid.*

⁴⁸ NOAA 2007, citing Gewant, D. S. and S. M. Bollens. 2005. Macrozooplankton and Micronekton of the Lower San Francisco Estuary: Seasonal, Interannual, and Regional Variation in Relation to Environmental Conditions. *Estuaries* 28(3):473-485.

⁴⁹ NOAA. 2007. *ibid.*

⁵⁰ CDFG 2000–2008. *Interagency Ecological Program for San Francisco Estuary*. Monthly Mid-water and Otter-Trawl Survey Data for San Francisco Estuary.

IV. Environmental Setting and Impacts
M. Biological Resources

Species present in the Central Bay also include white croaker, longfin smelt, American shad, Chinook salmon, white seaperch, plainfin midshipman, bay goby, whitebait smelt, bat ray, threadfin shad, California halibut, Pacific staghorn sculpin, Pacific tomcod, big skate, speckled sanddab, English sole, surf smelt, brown smoothhound, Pacific electric ray, barred surfperch, threespine stickleback, diamond turbot, leopard shark, river lamprey, yellowfin goby, striped bass, starry flounder, cheekspot goby, bay pipefish, queenfish, lingcod, white seabass, pile perch, unidentified rockfish, kelp greenling, black perch, and redbtail surfperch.

Table IV.M.2: Pelagic Fish Community Composition and Abundance Indices for Combined Shallow and Deep Water Sites near Treasure Island,¹ Based on Midwater Trawl Data, 2000 - 2008 (fish per hectare-m)

Species ²	Common Name	2000	2001	2002	2003	2004	2005	2006	2007	2008	Mean	% Comp.
<i>Engraulis mordax</i>	northern anchovy	528	581	378	351	1418	971	399	890	412	659	91.2%
<i>Clupea pallasii</i>	Pacific herring	131	57	18	10	8	13	92	47	41	46	6.4%
<i>Atherinopsis californiensis</i>	jacksmelt	8	5	6	2	1	10	4	2	6	5	0.7%
<i>Cymatogaster aggregata</i>	shiner perch	8	3	2	6	1	1	2	1	4	3	0.4%
<i>Atherinops affinis</i>	topsmelt	2	2	2	1	2	2	4	4	1	2	0.3%
<i>Sardinops sagax</i>	Pacific sardine	0	8	5	2	1	0	0	0	2	2	0.3%
<i>Hyperprosopon argenteum</i>	walleye surfperch	5	1	1	1	0	0	1	1	2	1	0.2%
<i>Leuresthes tenuis</i>	California grunion	0	2	2	4	0	0	0	0	0	1	0.1%
<i>Peprilus simillimus</i>	Pacific pompano	3	1	0	0	0	1	0	1	2	1	0.1%

Note:

¹ CDFG/IEP trawl data, Stations 109, 110, 211, 212, and 214.

² Additional fish species that were present in the trawls at less than significant numbers include: white croaker, longfin smelt, American shad, Chinook salmon, white seaperch, plainfin midshipman, bay goby, whitebait smelt, bat ray, threadfin shad, California halibut, Pacific staghorn sculpin, Pacific tomcod, big skate, speckled sanddab, English sole, surf smelt, brown smoothhound, Pacific electric ray, barred surfperch, threespine stickleback, diamond turbot, leopard shark, river lamprey, yellowfin goby, striped bass, starry flounder, cheekspot goby, bay pipefish, queenfish, lingcod, white seabass, pile perch, unidentified rockfish, kelp greenling, black perch, and redbait surfperch.

Source: CDFG 2000-2008

Terrestrial Wildlife and Marine Mammals

Invertebrates

Recent surveys carried out by entomologists have catalogued several butterflies and moths that use habitat on Yerba Buena Island, including the orange tortrix moth (*Argyrotaenia franciscana*), which is rarely found in San Francisco;⁵¹ the umber skipper (*Poanes melane*); and the rural skipper (*Ochlodes agricola*), which is a new breeding species for San Francisco and an island endemic that has not been documented from the mainland.⁵² Other species that have not been observed but are likely to occur on Yerba Buena Island due the presence of their host plants

⁵¹ Powell, J., Professor of Entomology, UC Berkeley, email to L. O'Brien, re: Yerba Buena Island butterflies, June 7, 2009.

⁵² O'Brien, L., lepidopterist, email to M. Wood. 2009. re: New Butterfly for S.F. County found on Yerba Buena Island. June 5, 2009.

IV. Environmental Setting and Impacts
M. Biological Resources

include the echo blue (*Celastrina argiolus*), Mylitta crescent (*Phyciodes mylitta*), painted lady (*Vanessa cardui*), sandhill skipper (*Polites sabuleti*), woodland skipper (*Ochlodes sylvanoides*), acmon blue (*Plebejus acmon*), and green hairstreak (*Callophrys rubi*).

Dutchman's pipevine is the host plant for the pipevine swallowtail butterfly (*Battus philenor*). While not of high conservation concern generally, the pipevine swallowtail butterfly is now very

rare in San Francisco and is indicative of an intact native habitat for Dutchman's pipevine. "Hilltopping" is a phenomenon among mating butterflies, a mate-searching strategy where males and virgin or multiple-mating females seek a topographical summit on which to mate. Mated females descend from the summits thereafter to search for host plants.

Herpetofauna (Reptiles and Amphibians)

Western fence lizards (*Sceloporus occidentalis*) have been observed on Yerba Buena Island. Alligator lizards (*Elgaria multicarinata multicarinata*), California slender salamander (*Batrachoseps attenuatus*), common garter snakes (*Thamnophis sirtalis*), and gopher snakes (*Pituophis catenifer catenifer*) are likely residents of the island as well.

Breeding Birds

Using the *San Francisco Breeding Bird Atlas*,⁵³ two bird lists from Golden Gate Audubon bird surveys,^{54,55} and a breeding bird monitoring report,⁵⁶ ESA compiled a list⁵⁷ of species that have been observed on Yerba Buena Island and in the waters nearby, shown below. In the list, species marked with an asterisk are potential or actual nesters on Yerba Buena Island. Species marked with a double asterisk are non-native, or are those most likely to breed in the disturbed/urbanized landscape of Treasure Island.

In addition, birds that use the Bay Bridge for nesting or regular roosting and would predictably use Treasure and Yerba Buena Islands and adjacent Bay waters for foraging or roosting include the American peregrine falcon (*Falco peregrinus anatum*) and double-crested cormorant (*Phalacrocorax auratus*).

⁵³ *San Francisco Breeding Bird Atlas*. N.d. San Francisco Field Ornithologist's Home Page, <http://www.sffo.org>. Accessed June 1, 2003.

⁵⁴ Hopkins, 2002. Yerba Buena Island Breeding Bird Survey, May 4, 2002.

⁵⁵ Golden Gate Audubon Society. 2007. *Yerba Buena Island Bird Walk*, January 10, 2007, <http://natureinthecity.org>. Accessed October 13, 2009.

⁵⁶ GANDA, 2003. *Yerba Buena Island Nesting Bird Survey for the Bay Bridge Project*. Prepared for Caltrans, June 5, 2003.

⁵⁷ Species are arranged in taxonomic order.

IV. Environmental Setting and Impacts
M. Biological Resources

- *Gavia immer*; Common loon
- *Podiceps auritus*; Horned grebe
- *Podiceps nigricollis*; Eared grebe
- *Aechmophorus occidentalis*; Western grebe
- *Aechmophorus clarkia*; Clark's grebe
- *Pelecanus occidentalis*; California brown pelican
- *Phalacrocorax auritus*; Double-crested cormorant*
- *Phalacrocorax pelagicus*; Pelagic cormorant
- *Phalacrocorax penicillatus*; Brandt's cormorant
- *Nycticorax nycticorax*; Black-crowned night-heron*
- *Branta canadensis*; Canada goose*
- *Anas platyrhynchos*; Mallard
- *Anas strepera*; Gadwall
- *Bucephala albeola*; Bufflehead
- *Cathartes aura*; Turkey vulture
- *Buteo jamaicensis*; Red-tailed hawk*
- *Charadrius vociferus*; Killdeer*
- *Recurvirostra americana*; American avocet
- *Himantopus mexicanus*; Black-necked stilt
- *Actitis macularia*; Spotted sandpiper
- *Larus occidentalis*; Western gull*
- *Hydroprogne caspia*; Caspian tern
- *Sterna forsteri*; Forster's tern
- *Zenaida macroura*; Mourning dove**
- *Columbia livia*; Rock dove*
- *Calypte anna*; Anna's hummingbird*
- *Selasphorus sasin*; Allen's hummingbird*
- *Sayornis nigricans*; Black phoebe**
- *Corvus corax*; Common raven*
- *Cyanocitta stelleri*; Steller's jay*
- *Aphelocoma californica*; Western scrub jay*
- *Petrochelidon pyrrhonota*; Cliff swallow*
- *Hirundo rustica*; Barn swallow*
- *Poecile rufescens*; Chestnut-backed chickadee*
- *Psaltriparus minimus*; Bushtit*
- *Certhia Americana*; Brown creeper*
- *Regulus calendula*; Ruby-crowned kinglet
- *Turdus migratorius*; American robin**
- *Catharus guttatus*; Hermit thrush
- *Mimus polyglottos*; Northern mockingbird*
- *Sturnus vulgaris*; European starling**
- *Bombycilla cedrorum*; Cedar waxwing
- *Vermivora celata*; Orange-crowned warbler*
- *Dendroica coronata*; Yellow-rumped warbler
- *Dendroica townsendi*; Townsend's warbler
- *Wilsonia pusilla*; Wilson's warbler*
- *Piranga ludoviciana*; Western tanager
- *Pheucticus melanocephalus*; Black-headed grosbeak
- *Pipilo maculatus*; Spotted towhee*
- *Pipilo crissalis*; California towhee*
- *Zonotrichia atricapilla*; Golden-crowned sparrow
- *Zonotrichia leucophrys*; White-crowned sparrow*
- *Passerella iliaca*; Fox sparrow
- *Melospiza melodia*; Song sparrow*
- *Junco hyemalis*; Dark-eyed junco*
- *Molothrus ater*; Brown-headed cowbird*
- *Agelaius phoeniceus*; Red-winged blackbird*
- *Euphagus cyanocephalus*; Brewer's blackbird**
- *Icterus bullockii*; Bullock's oriole
- *Carpodacus mexicanus*; House finch**
- *Carduelis pinus*; Pine siskin
- *Carduelis tristis*; American goldfinch*
- *Carduelis psaltria*; Lesser goldfinch*

- In addition, the San Francisco Breeding Bird Atlas lists 22 species as confirmed or probable breeding birds on Treasure Island.

- Double-crested cormorant
- Pelagic cormorant
- Brandt's cormorant
- Black-crowned night-heron
- Killdeer
- Western gull
- Mourning dove
- Anna's hummingbird
- Allen's hummingbird
- Common raven
- Chestnut-backed chickadee
- Bushtit
- American robin
- *Sitta canadensis*, Red-breasted nuthatch
- European starling
- White-crowned sparrow
- Song sparrow
- Red-winged blackbird
- Brewer's Blackbird
- House finch
- American goldfinch
- House Sparrow

Mammals

Terrestrial Mammals

Yerba Buena Island also provides habitat for two small mammal species: the pocket gopher and the California ground squirrel (*Spermophilus beecheyi*). Raccoons (*Procyon lotor*) have in the past made their way across the Bay Bridge and are currently known to be on the island. In fact, these omnivores are somewhat problematic on Yerba Buena Island — they forage in the lower intertidal zones along the west side of the island feeding on mossy chitons (*Mopalia muscosa*). Raccoons could be present on Treasure Island as well.

ESA investigated the presence of bats on Yerba Buena Island in August 2009. Acoustic detectors were placed in eucalyptus woodland and adjacent to an area of open grassland and coastal scrub. Calls recorded overnight on two occasions indicate that Mexican-free tailed bats (*Tadarida brasiliensis*) are the prevalent species on the island. These bats are not listed as a special-status

species, but their presence is taken into account in the management actions proposed in the HMP. These surveys were not exhaustive, and there may be other bat species that use habitat on Yerba Buena Island or, possibly, buildings on Treasure Island.

The occasional California mule deer (*Odocoileus hemionus californicus*) has been known to swim to Yerba Buena Island,⁵⁸ but the species has not established a population there.

Marine Mammals

Seven species of marine mammals are known to occur in the Bay waters surrounding the Islands. The two most common and predominant are the harbor seal (*Phoca vitulina*) and the California sea lion (*Zalophus californianus*). Harbor seals are the only year-round residents of the Bay-Delta, with colonies at Castro Rocks in San Pablo Bay, Yerba Buena Island in the Central Bay, and Mowry Slough in the South Bay.⁵⁹ The year-around harbor seal “haul-out” on Yerba Buena Island’s southwestern corner is part of the U.S. Coast Guard lands and outside of the Project Area. This haul-out is not known to be a pupping site for seals, but pups are occasionally observed there.⁶⁰ The current Bay-Delta harbor seal population is estimated at between 500 and 700 individuals.⁶¹ Harbor seals forage throughout the Bay-Delta

● and in nearshore coastal waters, feeding on schooling fish such as smelt, anchovies, and herring, rockfish, sculpin, perch, and midshipmen, along with squid and mysid shrimp, most of which are common inhabitants in the waters surrounding the Islands.

Special-Status Plants

There are several special-status plant species on Yerba Buena Island. For the purposes of this EIR, the term ‘special-status species’ is defined as those plant species that are:

- Listed by the Federal or State government as threatened or endangered;
- Listed by the State as rare;
- Listed at the State-level by the CNPS as species of conservation concern; or
- Listed by the CNPS Yerba Buena Chapter as locally significant.

No State or Federally listed (i.e., considered threatened or endangered) plant species have been documented on Yerba Buena Island, despite extensive plant surveys conducted over the past

⁵⁸ Anecdotal information posted on Nature in the City’s Yerba Buena Island Local Ecology web page, <http://natureinthecity.org/ybi.php>.

⁵⁹ NOAA. 2007. op.cit.

⁶⁰ Kopec, D. and Harvey, J. 1995. *Toxic pollutants, health indices, and population dynamics of harbor seals in San Francisco Bay, 1989-91: a final report*. Technical publication. Moss Landing, CA: Moss Landing Marine Labs.

⁶¹ NOAA 2007, citing Grigg, E. K., S. G. Allen, D. E. Green, and H. Markowitz. 2004. Harbor Seal, *Phoca vitulina richardii*, Population Trends in the San Francisco Bay Estuary, 1970-2002. California Fish and Game 90(2): pp 51-70.

decade. There are several populations of the CNPS-listed species dune gilia on the island (e.g., observed on the west-facing slope of Yerba Buena Island, below Treasure Island Road). Dune gilia is included on the CNPS list of species of conservation concern (see “Regulatory Framework,” p. IV.M.37) because it is restricted to only a few occurrences in Marin, San Francisco, and Sonoma Counties.

The remaining special-status plants are of local significance—plant species known from only one or very few locations on the San Francisco Peninsula. These species have no protected status under existing laws or policies. Although these species may be widespread elsewhere, their small populations in San Francisco represent a unique local biological resource. The CNPS Yerba Buena Chapter maintains a list of locally significant species for San Francisco County on their website, http://www.cnps-yerbabuena.org/experience/plant_guides.html. There are nine locally significant plant species occurring on Yerba Buena Island and two species proposed for addition to the list:

- California buckeye
- California hazelnut
- Cobwebby thistle*
- Coffee fern (*Pellaea andromedifolia*)
- Dutchman’s pipevine*
- Fiesta flower (*Pholistoma auritum*)
- Hollyleaf cherry (*Prunus ilicifolia*) (based on this species’ distribution this is not likely to be a native occurrence)
- Maidenhair fern (*Adiantum pedatum*)
- Serpentine springbeauty (*Claytonia exigua* ssp. *exigua*)
- Wood rose (*Argyrea nervosa*)
- Vancouver’s ryegrass (*Leymus xvancouverensis*)

*Proposed for addition to CNPS locally significant plants list

Special-Status Wildlife and Fish Species Considered in this EIR

A number of species known to occur in the Proposed Project vicinity are protected pursuant to Federal and/or State of California endangered species laws, or have been designated Species of Special Concern by CDFG. In addition, Section 15380(b) of the *CEQA Guidelines* provides a definition of rare, endangered, or threatened species that are not included in any listing.⁶² Species recognized under these terms are collectively referred to as “special-status species.” For the purposes of this EIR, special-status species include:

⁶² For example, vascular plants listed as rare or endangered or as List 1 or 2 by the CNPS are considered subject to Section 15380(b).

- Wildlife species listed as rare, threatened or endangered under the Federal or State endangered species acts;
- Species that are candidates for listing under either Federal or State law;
- Species formerly designated by the U.S. Fish and Wildlife Service (“USFWS”) as Species of Concern or designated by the California Department of Fish and Game (“CDFG”) as Species of Special Concern;
- Species protected by the Federal Migratory Bird Treaty Act (16 U.S.C. 703–711) or the Marine Mammal Protection Act; and/or
- Species such as candidate species that may be considered rare or endangered pursuant to Section 15380(b) of the *CEQA Guidelines* (see “Regulatory Framework,” p. IV.M.35).

Determining which special-status species of terrestrial wildlife and fish may be subject to development impacts can be difficult when the project site is an island. Islands, by virtue of their isolation, support fewer animals, but multiple species may pass through them and be indirectly affected by the Proposed Project. For the purposes of this EIR, the itinerant animals shown to use the Islands specifically and the fish for which migratory routes near the Islands hold an official habitat designation are considered.

Special-Status Wildlife

There are no known Federally or State listed terrestrial wildlife species known to breed on the Islands. As mentioned earlier, the Federally delisted peregrine falcon and the double-crested cormorant, whose nesting colonies are protected by CDFG, are known to nest on the Bay Bridge and may use the Islands or surrounding waters for foraging and roosting. The Federally endangered brown pelican may also use offshore structures and forage in the waters off the Islands. Also, as noted above, there is a year-round harbor seal “haul-out” on the southwestern corner of Yerba Buena Island. These species are described in more detail below.

American Peregrine Falcon (Falco peregrinus anatum)

American peregrine falcon is no longer Federally listed but is State listed as endangered. The peregrine falcon was fairly common in California before 1947, with at least 100 nesting pairs counted.⁶³ The peregrine falcon was placed on the Federal endangered species list in 1970, when fewer than five pairs were believed to nest in all of California. Currently, an estimated 10 to 20 birds range over the San Francisco Bay area and delta region.⁶⁴ Other bird species are prey for the peregrine falcon, including pigeons, terns, blackbirds, sparrows, and shorebirds.

⁶³ USFWS. 1992. *Status and Trends Report on wildlife of the San Francisco Estuary*. Prepared under EPA Cooperative Agreement CE-009519-01-0 by the U.S. Fish and Wildlife Service for the San Francisco Estuary Project.

⁶⁴ USFWS. 1992. *ibid.*

Double-Crested Cormorant (*Phalacrocorax auritus*)

A State species of special concern, the cormorant is a year-long resident along the entire coast of California and is known to frequent inland lakes and fresh, salt, and estuarine waters. Fish make up the bulk of the double-crested cormorant's diet, while crustaceans and amphibians are known to be taken as food items to a lesser degree. It feeds during the day and is known to roost beside water on offshore rocks, islands, steep cliffs, trees, or engineered structures (wharves, jetties, and bridges) barren of vegetation. Nests are built in habitats similar to those used for roosting, with further requirements that the area be inaccessible to predators, that it be near a foraging area, and that it have a dependable food supply.

California Brown Pelican (*Pelecanus occidentalis californicus*)

A Federally and State-listed endangered species,⁶⁵ brown pelicans are found in estuarine, marine subtidal, and marine pelagic waters throughout coastal California.⁶⁶ Important habitat for pelicans during the non-breeding season includes roosting and resting areas, such as offshore rocks, islands, sandbars, breakwaters, and pilings. Suitable areas need to be free of disturbance. They rest temporarily on the water or isolated rocks, but roosting requires a dry location near food and a buffer from predators and humans. California brown pelicans use open water areas for feeding and use rocks, jetties, and piers for roosting. Brown pelicans feed on small surface-schooling fish, primarily anchovy.⁶⁷ California brown pelicans migrate from their breeding zones in the Channel Islands and Mexico as early as mid-May and disperse throughout coastal California. The California brown pelican is a common post-breeding resident (May through November) of the open waters of the central San Francisco Bay.

Harbor Seal (*Phoca vitulina richardsi*)

The harbor seal is a permanent resident in San Francisco Bay and is routinely seen in waters off the Islands. Harbor seals are protected under the Marine Mammal Protection Act ("MMPA"). They have been observed as far upstream in the Delta and Sacramento River as the City of Sacramento, though their use of the habitat north of Suisun Bay is irregular.⁶⁸

Seals haul out year-round on Yerba Buena Island. The haul-out area is within the region of influence but not within the boundaries of the Proposed Project. As noted above, the Yerba Buena Island haul-out site is on the southeast side of the island, on U.S. Coast Guard property.

⁶⁵ In February, 2009, the California Fish and Game Commission voted unanimously to remove the California brown pelican from the State endangered species list.

⁶⁶ Thelander *et al.*, 1994. *Life on the Edge*. BioSystems Books, Santa Cruz, California.

⁶⁷ Zeiner *et. al.* 1990. *California's Wildlife Volume II, Mammals*. California Department of Fish and Game.

⁶⁸ Goals Project. 2000. *Baylands Ecosystem Species and Community Profiles: Life Histories and Environmental Requirements of Key Plants, Fish and Wildlife*. Prepared by the San Francisco Bay Area Wetlands Ecosystem Goals Project. P.R. Olofson, ed. San Francisco Bay Regional Water Quality Control Board, Oakland, California.

Individual seals may occasionally haul out farther to the west and southwest of the main haul-out site, depending on space availability and conditions at the main haul-out area. Harbor seals feed in the deepest waters of the Bay, with the region from the Golden Gate to Treasure Island and south to the San Mateo Bridge, being the principal feeding sites.⁶⁹ Harbor seals feed on a variety of fish, such as perch, gobies, herring, and sculpin.

Special-Status Fish Species⁷⁰

Table IV.M.3 lists special-status fish species that may occur near the Proposed Project area. These species are discussed in detail below.

Sacramento River Winter-Run Chinook Salmon (*Oncorhynchus tshawytscha*)

Sacramento River winter-run Chinook salmon is Federally and State-listed as endangered. Winter-run Chinook salmon migrate and spawn from mid-December to August, along the Sacramento River, up to Keswick Dam in Shasta County. Adult winter-run Chinook salmon can be found in San Francisco Bay beginning November through December, with individuals remaining only a few days.⁷¹ Juveniles emigrate from their initial upstream habitat to the Bay in the fall. Although most individual juveniles remain in the Bay only for 4 to 10 days⁷² some may stay for several months⁷³ using the habitat for rearing.⁷⁴ Winter run Chinook may occur in the Central Bay and in the project area in low numbers.⁷⁵

⁶⁹ Kopec, D. and Harvey, J. 1995. *op. cit.*

⁷⁰ Much of the information was drawn directly from the *Final Environmental Impact Report for the Transfer and Re-use of Naval Station Treasure Island*, as peer reviewed by AMS.

⁷¹ Herbold, B. and P. B. Moyle. 1989. Ecology of the Sacramento-San Joaquin Delta: A Community Profile. U.S. Fish and Wildlife Service Biological Report 85(7.22) September. 106 pages

⁷² Herbold, B. and P.B. Moyle. 1989. *Ibid.*

⁷³ Myers et. al. 1998 Status review of Chinook salmon from Washington, Idaho, Oregon, and California. U.S. Dept. of Commerce, NOAA Tech Memo. NMFS (now known as NOAA Fisheries)-NWFSC-35.

⁷⁴ Healey, M.C. 1991. "Life History of Chinook Salmon (*Oncorhynchus tshawytscha*)," pp. 331-393. In: *Pacific Salmon Life Histories*, C.Groot and L. Margolis, eds. University of British Columbia Press, Vancouver, British Columbia.

⁷⁵ Woodbury, David. 2001. National Marine Fisheries Service (now known as NOAA Fisheries), Fisheries Biologist. Personal communication with Jeanette Weismann, Tetra Tech. December 7, 2001.

● **Table IV.M.3: Special-Status Fish Species that May Occur Within the Proposed Project Vicinity**

Common Name <i>Scientific Name</i>	Status¹ F/S	Preferred Habitat	Likelihood of Occurrence in Project Area²	Comments
Central California coast coho salmon <i>Oncorhynchus kisutch</i>	T/E	Migrates from ocean through estuaries to freshwater streams	P	Migrates through Bay
Central California coast steelhead trout <i>O. mykiss</i>	T/-	Migrates from oceans through estuaries to freshwater	P	Migrates through Bay
Central Valley fall run/late fall run chinook salmon <i>O. tshawytscha</i>	C/-	Migrates from oceans through estuaries to freshwater	P	Migrates through Bay
Central Valley spring run chinook salmon <i>O. tshawytscha</i>	T/-	Migrates from oceans through estuaries to freshwater	P	Migrates through Bay
Central Valley steelhead trout <i>O. Mykiss</i>	T/-	Migrates from oceans through estuaries to freshwater	P	Migrates through Bay
Green Sturgeon <i>Acipenser medirostris</i>	T/C	Marine and estuarine environments	C	Anadromous, migrates into Central Bay
Longfin smelt <i>Spirinchus thaleichthys</i>	-/T	Open waters of the Bay	P	Found throughout open water areas
Sacramento River winter-run chinook salmon <i>Oncorhynchus tshawytscha</i>	E/E	Migrates from oceans through estuaries to freshwater	P	Migrates through Bay

Notes:

¹ Status

F = Federal

S = State

E = listed as endangered

T = listed as threatened

SC = species of concern

C = candidate

² Likelihood of occurrence on the project site

C = Confirmed

P = Potentially may occur

Source: Applied Marine Science 2010

Winter-run Chinook salmon critical habitat⁷⁶ (see “Regulatory Framework,” p. IV.M.33, for a further explanation of this term) includes all waters of San Francisco Bay north of the Bay Bridge. The Proposed Project area lies partially within this critical habitat area, with the water surrounding the islands north of the bridge qualifying as winter-run Chinook critical habitat.⁷⁷ Figure IV.M.2: Critical Habitat and EFH for Chinook and Coho ESUs, depicts critical habitat and essential fish habitat for this population in the vicinity of the Project Area.

Central Valley Spring-Run Chinook Salmon (*O. tshawytscha*)

A Federally listed threatened Evolutionarily Significant Unit (“ESU”),⁷⁸ the spring-run Chinook salmon has a similar life history to the winter run salmon but begins its spawning migration to the Sacramento/San Joaquin Delta in late winter to spring. Adults are found in San Francisco Bay during the migratory period in the spring, and juveniles have the potential to inhabit the Bay in the fall, winter, and spring. Spring-run chinook may occur in the Central Bay and in the vicinity of the Proposed Project area in low numbers.⁷⁹

Critical habitat for the Central Valley spring-run Chinook salmon includes all waters of San Francisco Bay north of the Bay Bridge.⁸⁰ The Project Area lies partially within this critical habitat area, with the water surrounding the islands north of the Bay Bridge qualifying as spring-run Chinook critical habitat. Figure IV.M.2 shows critical habitat and essential fish habitat for this ESU in the vicinity of the Project Area.

Central Valley Fall-Run/Late Fall-Run Chinook Salmon

Adult fall-run/late fall-run Chinook salmon begin their migration toward their spawning grounds in June, with a peak in September. They spawn in the Sacramento/San Joaquin Delta during December and January.⁸¹ Juvenile salmon potentially occur in San Francisco Bay in the late winter through summer. The primary threats to the fall-run/late fall-run chinook salmon are the impacts from high hatchery production and harvest levels and from the loss of 40 to 50 percent of

⁷⁶ Critical habitat is a specific geographic area(s) that is essential for the conservation of a threatened or endangered species and that may require special management and protection.

⁷⁷ National Marine Fisheries Service (now known as NOAA Fisheries), Northwest Region (NMFS NWR). 2000. Chinook Salmon Central Valley Spring-Run ESU, <http://www.nwr.noaa.gov/1salmon/salmesa/chincvs.htm>. Accessed July 26, 2001.



⁷⁸ An “evolutionarily significant unit” is a population of organisms that is considered distinct for purposes of conservation.

⁷⁹ Woodbury. 2001. *op. cit.*

⁸⁰ NMFS. 2000, *op. cit.*

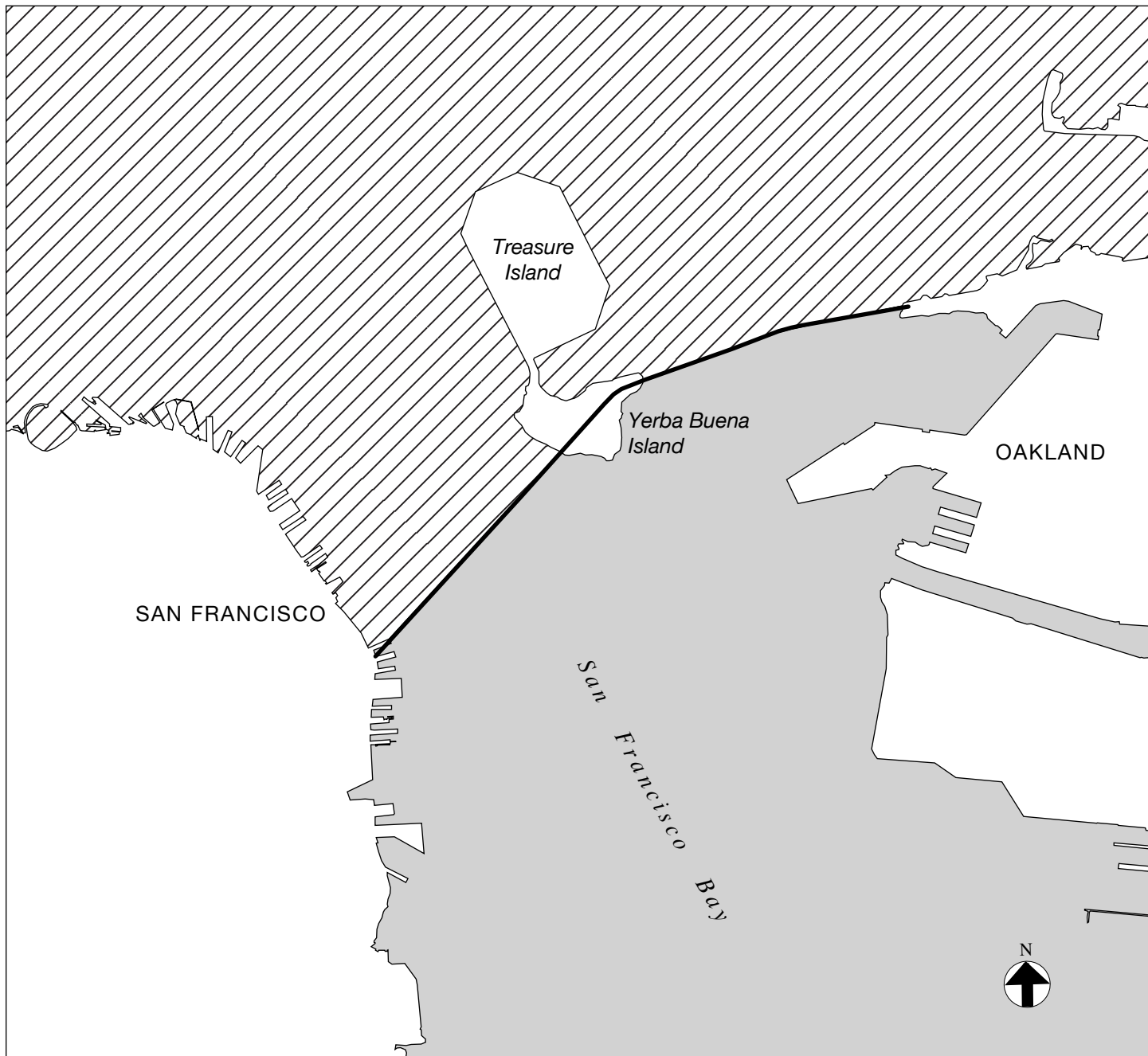
⁸¹ USFWS. 1999. *Endangered and Threatened Species; Threatened Status for Two Chinook Salmon Evolutionary Significant Units*. Federal Register Final Rule. Volume 64, Number 179, pp. 50,395-50,415. September 16, 1999.



-  Critical habitat for Sacramento River winter-run chinook salmon and Central Valley spring-run chinook salmon and central California coast coho salmon
-  EFH for Sacramento River winter-run chinook salmon, Central Valley spring-run chinook salmon, Central Valley fall-run/late fall-run chinook salmon and central California coast coho salmon

EFH - Essential Fish Habitat
 ESU - Evolutionarily Significant Unit

SOURCE: NMFS, 2001; NMFS SWR, 1998

spawning and rearing habitat.⁸² There is no critical habitat designated for this species. Figure IV.M.2 depicts essential fish habitat for this ESU in the vicinity of the Project Area.

Central Valley Steelhead Trout (*O. mykiss*)

The Central Valley steelhead is Federally listed as a threatened ESU and has no State status. Central Valley steelhead migrate between the ocean and the Sacramento and San Joaquin rivers and their tributaries via the San Francisco and San Pablo bays. Upstream migration occurs in the winter, with peak spawning occurring December through April.⁸³ Most Central Valley steelhead juveniles rear in freshwater for one to two years and can be found migrating downstream at any time of the year, with peak emigration typically occurring in the spring. This ESU has the potential to occur in the Central Bay, and therefore in the vicinity of the Project Area, but if present, are present in very low numbers and only occasionally.⁸⁴

The primary threats to Central Valley steelhead are degradation and loss of critical spawning and rearing grounds due to dam development and water diversions.⁸⁵ Critical habitat for Central Valley steelhead includes the waters of San Francisco Bay north of the Bay Bridge.⁸⁶ This includes the waters in the vicinity of the Project Area.

Central California Coast Coho Salmon (*O. kisutch*)

The Central California coast coho salmon is a Federally listed threatened and State-listed endangered ESU. Adult coho migrate through San Francisco Bay after heavy late fall or winter rains to spawn in the Sacramento/San Joaquin Delta. Juvenile coho potentially occur in the San Francisco Bay in the spring, summer, and fall and may be present in the Central Bay, and therefore in the vicinity of the Project Area, in low numbers.⁸⁷

Critical habitat for Central California coast coho includes all river reaches, including estuarine areas and tributaries, accessible to listed coho salmon, between Punta Gorda in northern

⁸² NMFS. 1999. Fact Sheet West Coast Chinook Salmon.

<http://www.nwr.noa.gov/1salmon/salmesa/pubs/99chinfs.htm>. Accessed October 2, 2001.

⁸³ McEwan, D., and T.A. Jackson. 1996. *Steelhead Restoration and Management Plan for California*. California Department of Fish and Game, Inland Fisheries Division. Sacramento, California.

⁸⁴ CDFG 2000-2008. *op. cit.*

⁸⁵ McEwan, D., and T.A. Jackson. 1996. *ibid.*

⁸⁶ NOAA. 2005. Endangered and Threatened Species; Designation of Critical Habitat for Seven Evolutionarily Significant Units of Pacific Salmon and Steelhead in California; Final Rule. 9 Federal Register 70 (170): 52488-52585. September 2, 2005.

⁸⁷ Woodbury. 2001. *op. cit.*

California south to the San Lorenzo River in central California. The critical habitat area includes the waters surrounding Treasure Island and north of the Bay Bridge.⁸⁸

Central California Coast Steelhead Trout (*O. mykiss*)

The Central California coast steelhead trout is Federally listed as threatened. Steelhead are rare in most streams that are tributary to San Francisco Bay.

Central California coast steelhead migrate from the Pacific coast through San Francisco Bay in the winter to spawn in freshwater in the upper Sacramento River.⁸⁹ They are also known to migrate to the South Bay, where they spawn in the Guadalupe River, Coyote Creek, and San Francisquito Creek.⁹⁰ Upstream migration occurs from December through May, and peak spawning occurs in April. Juveniles may spend a year or more in San Francisco Bay before moving on to the ocean. This population is known to occur in the Central Bay, and in the Project Area, in moderate numbers. The Central California coast steelhead may be present in the region of influence at any time of the year.

Critical habitat includes all river reaches and estuarine areas accessible to listed steelhead in coastal river basins, from the Russian River to Aptos Creek (inclusive), and the drainages of San Francisco and San Pablo Bays. Also included are adjacent riparian zones, all waters of San Pablo Bay west of the Carquinez Bridge, and all waters of San Francisco Bay.⁹¹ All of the Bay waters surrounding Treasure Island and Yerba Buena Island fall within this critical habitat range. Figure IV.M.3: Critical Habitat for Steelhead ESUs, depicts critical habitat in the vicinity of the Project Area.

Green Sturgeon (*Acipenser medirostris*)

This anadromous⁹² fish is the most widely distributed member of the sturgeon family and the most marine-oriented of the sturgeon species. It is listed as a Federal threatened species and as a State species of concern. Green sturgeons range in nearshore coastal waters from Mexico to the Bering Sea and are common occupants of bays and estuaries along the western coast of the

⁸⁸ NOAA. 2005. *op. cit.*



⁸⁹ McEwan, D., and T.A. Jackson. 1996. *Steelhead Restoration and Management Plan for California*. California Department of Fish and Game, Inland Fisheries Division. Sacramento, California.

⁹⁰ Woodbury. 2001. *op. cit.*

⁹¹ USFWS. 2000. *Designated Critical Habitat: Critical Habitat for 19 Evolutionary Significant Units of Salmon and Steelhead in Washington, Oregon, Idaho, and California*. Federal Register, Volume 65, Number 32, February 16, 2000.

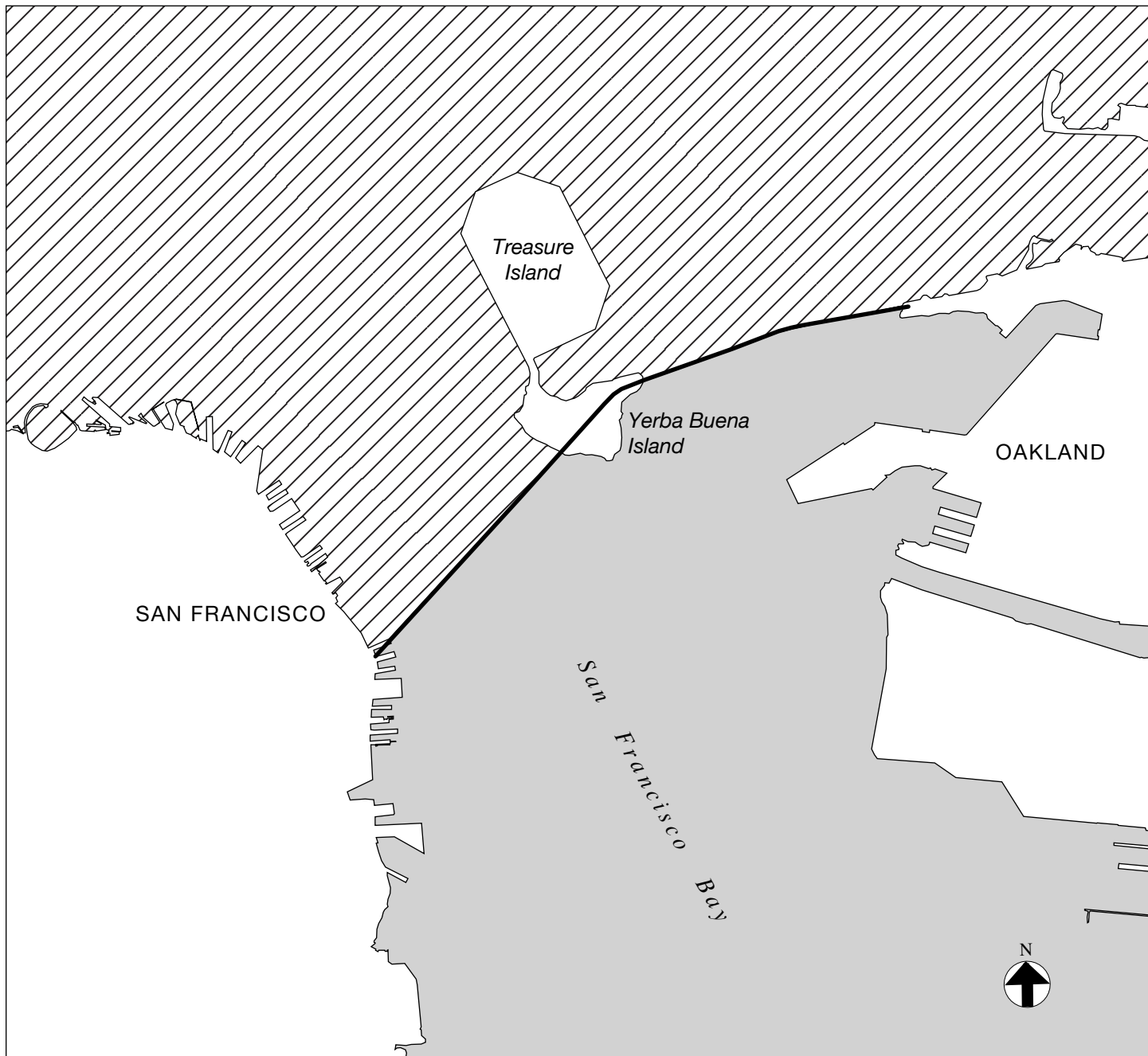
⁹² Anadromous fish are those migrating from the sea to fresh water to spawn.



-  Critical habitat for Central Valley steelhead
-  Critical habitat for central California coast steelhead

ESU - Evolutionarily Significant Unit

SOURCE: NMFS, 2001; NMFS SWR, 1998

TREASURE ISLAND AND YERBA BUENA ISLAND REDEVELOPMENT PROJECT EIR

FIGURE IV.M.3: CRITICAL HABITAT FOR STEELHEAD ESUs

United States.⁹³ Adults in the San Joaquin Delta are reported to feed on benthic invertebrates including shrimp, amphipods and occasionally small fish⁹⁴ while juveniles have been reported to feed on opossum shrimp and amphipods. Adult green sturgeons migrate into freshwater beginning in late February with spawning occurring in March through July, and peak activity in April and June. After spawning, juveniles remain in fresh and estuarine waters for one to four years and then begin to migrate out to the sea.⁹⁵ The upper Sacramento River has been identified as the only known spawning habitat for green sturgeon in the southern distinct population segment. Critical habitat for the green sturgeon includes the Sacramento River, the Sacramento-San Joaquin Delta, and Suisun, San Pablo and San Francisco Bays.⁹⁶ CDFG Interagency Ecological Program⁹⁷ data for Central San Francisco Bay waters adjacent to Treasure Island (Tables IV.M.1 and IV.M.2) indicate that although green sturgeon can historically be found in the region of influence, they do not appear to be frequent or significant inhabitants.

Longfin Smelt (*Spirinchus thaleichthys*)

This fish is a State-listed endangered species. The longfin smelt is a pelagic (living in open ocean) schooling fish known to inhabit the San Francisco Bay-Delta, including the waters surrounding Treasure Island (see Tables IV.M.1 and IV.M.2).^{98, 99} Although observed in Central San Francisco Bay waters throughout the year, smelt migrate to the fresher water of the Delta to spawn in the winter, returning to Bay waters in late spring. No Critical Habitat has been designated for this species.

Wetlands

Wetlands are considered “special-status” resources under criteria outlined in the *CEQA Guidelines*. The only jurisdictional wetland on the Islands (as opposed to the intertidal nearshore waters) is a small band of northern coastal salt marsh that occurs on the north side of Yerba Buena Island, adjacent to Clipper Cove.

⁹³ Moyle, P. B., R. M. Yoshiyama, J. E. Williams, and E. D. Wikramanayake. 1995. Fish Species of Special Concern of California, Second Edition, University of California, Davis, Department of Wildlife and Fisheries Biology, prepared for the California Department of Fish and Game, Rancho Cordova, CA. June.

⁹⁴ Moyle, *et al.* 1995. *ibid.*

⁹⁵ Moyle, *et al.* 1995. *ibid.*

⁹⁶ NOAA. 2009. Endangered and Threatened Wildlife and Plants: Final Rulemaking to Designate Critical Habitat for the Threatened Southern District Population Segment of North American Green Sturgeon. Federal Register 74 (195): 52300-52351. October 9, 2009.

⁹⁷ CDFG. 2000-2008. *op. cit.*

⁹⁸ CDFG, 2000-2008. *op. cit.*

⁹⁹ Hieb, Kathy. 2001. California Department of Fish and Game, Associate Biologist. Personal communications with Jeanette Weisman, Tetra Tech. December 7, 2001.

Trees

ESA used the guidance provided by San Francisco's Urban Forestry Ordinance (see "Regulatory Framework," pp. IV.M.38) to survey trees within the Development Plan Project Area. It is important to note that none of the areas on the Islands are actually subject to the SF Tree Ordinance, none of the streets are under the jurisdiction of the San Francisco Department of Public Works, and most existing streets would be relocated as part of the Proposed Project. However, the trees do provide nesting habitat for birds and are therefore evaluated in the Impacts section, below.

Table IV.M.4 presents a summary of all trees surveyed.

REGULATORY FRAMEWORK

This section briefly describes Federal, State, and local regulations, permits, and policies pertaining to biological resources found on or in the vicinity of the Proposed Project.

Federal Endangered Species Act

Under the Federal Endangered Species Act ("FESA"), the Secretary of the Interior and the Secretary of Commerce jointly have the authority to list a species as threatened or endangered (16 United States Code [USC] 1533(c)). Pursuant to the requirements of FESA, an agency reviewing a proposed project within its jurisdiction must determine whether any Federal listed threatened or endangered species may be present in the project area and determine whether the proposed project may affect or "take"¹⁰⁰ such species. In addition, the agency is required consult with the U.S. Fish and Wildlife Service ("USFWS") to determine whether the project is likely to jeopardize the continued existence of any species proposed to be listed under FESA or result in the destruction or adverse modification of critical habitat (see below) proposed to be designated for such species (16 USC 1536(3), (4)). Therefore, project impacts on listed or candidate species or their habitats would be considered "significant" in this EIR.

Consultation with either the USFWS or the National Oceanic and Atmospheric Administration, National Marine Fisheries Service ("NOAA Fisheries") would likely be required for the Proposed Project as a result of the U.S. Army Corps of Engineers' ("USACE") role in permitting the project under the Clean Water Act or the Rivers and Harbors Act (see below). At that time, the potential for take would be determined, and, if take is expected to occur, the necessary conditions to allow the issuance of an incidental take permit would be imposed.

¹⁰⁰ The definition of "take" is to "harass, harm, pursue, hunt, shoot, wound, trap, capture, or collect, or to attempt to engage in any such conduct. The USFWS has also interpreted "harm" to include significant habitat modification that could result in take.

Table IV.M.4: Summary of Surveyed Trees

Scientific Name	Common Name	Total Number Surveyed
<i>Abies</i> sp.	Fir	1
<i>Acacia melanoxylon</i>	Blackwood acacia	220
<i>Acer platanoides</i>	Norway maple	17
<i>Albizia lophantha</i>	Plume albizia	15
<i>Arbutus menziesii</i>	Madrone	2
<i>Betula</i> sp.	Birch	1
<i>Callistemon rigidus</i>	Bottlebrush	16
<i>Cercis occidentalis</i>	Redbud	2
<i>Cotoneaster lacteus</i>	Milkflower cotoneaster	1
<i>Cupressus macrocarpa</i>	Monterey cypress	47
<i>Eriobotrya japonica</i>	Loquat	1
<i>Eucalyptus ficifolia</i>	Redflower gum	28
<i>Eucalyptus globulus</i>	Tasmanian bluegum	294
<i>Eucalyptus sideroxylon</i>	Red ironbark	2
<i>Juniperus</i> sp.	Juniper	2
<i>Ligustrum lucidum</i>	Glossy privet	40
<i>Ligustrum</i> sp.	Privet	2
<i>Liriodendron tulipifera</i>	Tuliptree	8
<i>Metrosideros excelsa</i>	New Zealand Christmas tree	4
<i>Myrica californica</i>	California wax myrtle	173
<i>Olea europaea</i>	Olive	168
<i>Phoenix canariensis</i>	Canary Island palm	215
<i>Picea</i> sp.	Spruce	3
<i>Pinus halepensis</i>	Aleppo pine	40
<i>Pinus pinea</i>	Italian stone pine	25
<i>Pinus radiata</i>	Monterey pine	244
<i>Pittosporum eugenoides</i>	Lemonwood	1
<i>Pittosporum</i> sp.	Cheesewood	1
<i>Pittosporum undulatum</i>	Australian cheesewood	21
<i>Platanus hybrida</i>	London plane	58
<i>Populus nigra</i>	Lombardy poplar	13
<i>Prunus</i> sp.	Cherry	12
<i>Quercus agrifolia</i>	Coast live oak	36
<i>Quercus</i> sp.	Oak	1
<i>Salix lasiolepis</i>	Arroyo willow	1
<i>Sambucus mexicana</i>	Blue elderberry	3
<i>Schinus molle</i>	Peruvian peppertree	1
<i>Sequoia sempervirens</i>	Coast redwood	2
<i>Sequoiadendron giganteum</i>	Giant sequoia	1
<i>Syzygium paniculatum</i>	Brush cherry	2
<i>Ulmus</i> sp.	Elm	5
Unknown ornamental	Ornamental	22
<i>Washingtonia robusta</i>	Fan palm	12
<i>Yucca</i> sp.	Yucca	12
	Total	1,775

Source: ESA 2009

Areas of habitat considered essential to the conservation of a listed endangered or threatened species may be designated as critical habitat (referred to above), which is protected under the FESA. Although critical habitat may be designated on private or government property, activities on these properties are not restricted unless there is Federal involvement in the activities or direct harm to listed wildlife. The Project Area contains critical habitat for the following species, as designated by NOAA Fisheries:

- Central California coast coho salmon, October 3, 2000;
- Central California coast steelhead trout, February 16, 2000;
- Central Valley steelhead trout, February 16, 2000;
- Central Valley spring-run chinook salmon, February 16, 2000;
- Sacramento River winter-run chinook salmon, June 16, 1993; and
- • Green Sturgeon, October 9, 2009.

The USFWS also publishes a list of candidate species for listing. Species on this list receive special attention from Federal agencies during environmental review, although they are not otherwise protected under FESA. The candidate species are taxa for which the USFWS has sufficient biological information to consider listing as Endangered or Threatened.

California Endangered Species Act

Under the California Endangered Species Act (“CESA”), the CDFG maintains a list of threatened species and endangered species (California Fish and Game Code 2070). The CDFG also maintains a list of “candidate species,” which are species that the CDFG has formally noticed as being under review for addition to either the list of endangered species or the list of threatened species. The CDFG also maintains lists of “Species of Special Concern.” Pursuant to the requirements of CESA, an agency reviewing a proposed project within its jurisdiction must determine whether any State-listed endangered or threatened species may be present in the project area and determine whether the proposed project will have a potentially significant impact on such species. In addition, the CDFG encourages informal consultation on any proposed project that may affect a candidate species. Project impacts on species on the CESA endangered list or threatened list would be considered significant in this EIR. Impacts on Species of Special Concern (for example, the double-crested cormorant, and green sturgeon [previously discussed], and oystercatchers and plovers, which are occasional visitors) would be considered significant under certain circumstances, as discussed below.

Regulation of Wetlands and Other Waters

The regulations and policies of various Federal agencies (e.g., USACE, U.S. Environmental Protection Agency [“EPA”], and USFWS) mandate that the filling of wetlands be avoided unless it can be demonstrated that there is no practicable alternative to filling. The USACE has primary

Federal responsibility for administering regulations that concern waters and wetlands on the project site under statutory authority of the Rivers and Harbors Act (Sections 9 and 10) and the Clean Water Act (Section 404).

Pursuant to Section 10 of the Rivers and Harbors Appropriation Act of 1899 (33 U.S.C. 403), the USACE regulates the construction of structures in, over, or under, excavation of material from, or deposition of material into “navigable waters.” In tidal areas, the limit of navigable water is the mean high tide line; in non-tidal waters it is the ordinary high water mark (“OHWM”). Larger streams, rivers, lakes, bays, and oceans are examples of navigable waters regulated under Section 10 of the Rivers and Harbors Act. Historically navigable waters are those areas that are no longer navigable as a result of artificial modifications, such as levees, dikes and dams.

Section 404 of the Federal Clean Water Act (“CWA”) (33 U.S.C. 1251 – 1376) prohibits the discharge of dredged or fill material into waters of the U.S., including wetlands, without a permit from the USACE. The CWA prohibits the discharge of any pollutant without a permit. Implicit in the CWA definition of “pollutant” is the inclusion of dredged or fill material regulated by Section 404 (22 USC 1362). The discharge of dredged or fill material typically means adding into waters of the U.S. materials such as concrete, dirt, rock, pilings, or side cast material that are for the purpose of replacing an aquatic area with dry land or raising the elevation of an aquatic area. Activities typically regulated under Section 404 include the use of construction equipment such as bulldozers, and the leveling or grading of sites where jurisdictional waters occur.

The State’s authority in regulating activities in wetlands and waters at the site resides primarily with the State Water Resources Control Board (“SWRCB”). The SWRCB, acting through the San Francisco Regional Water Quality Control Board (“RWQCB”), must certify that a USACE permit action meets State water quality objectives (Section 401, CWA). Any condition of water quality certification is then incorporated into the USACE Section 404 permit authorized for the project.

The SWRCB and RWQCB also have jurisdiction over waters of the state under the Porter-Cologne Water Quality Control Act (Porter-Cologne). The SWRCB and RWQCB evaluate proposed actions for consistency with its Basin Plan, and authorize impacts on waters of the state by issuing Waste Discharge Requirements (“WDR”) or in some cases, a waiver of WDR.

The San Francisco Bay Conservation and Development Commission (“BCDC”) has jurisdiction over coastal activities occurring within the San Francisco Bay area and Suisun Marsh. BCDC was created by the McAteer-Petris Act (see below) in 1965. BCDC regulates filling and dredging in San Francisco Bay including San Pablo Bay, Suisun Bay and sloughs, and certain creeks and tributaries that are part of the Bay system. BCDC also has jurisdiction over a 100-foot shoreline band surrounding the Bay that extends from the mean high tide line inland. The Coastal Zone Management Act of 1972 (“CZMA”) requires that all applicants for Federal permits and Federal

agency sponsors obtain certification from the State's approved coastal program that a proposed project is consistent with the State's program. In San Francisco Bay, BCDC is charged with making this consistency determination.

CEQA Guidelines Section 15380

Although threatened and endangered species are protected by specific Federal and State statutes, *CEQA Guidelines* Section 15380(b), referred to above, provides that a species not listed on the Federal or State list of protected species may be considered rare or endangered if the species can be shown to meet certain specified criteria. These criteria have been modeled after the definition in FESA and the section of the California Fish and Game Code dealing with rare or endangered plants or animals. Section 15380(b) provides an agency with the discretion to determine that a species is rare, and that impacts on the species or its habitat could be significant, even if the resource agencies (USFWS, CDFG) have not formally listed the species as threatened or endangered.

Other Statutes, Codes, and Policies Affording Limited Species Protection

Migratory Bird Treaty Act

The Federal Migratory Bird Treaty Act (16 USC, Section 703, Supp. I, 1989) prohibits killing, possessing, or trading in migratory birds except in accordance with regulations prescribed by the Secretary of the Interior. This act applies to whole birds, parts of birds, and bird nests and eggs.

Fish and Game Code Sections 3503, 3511, 4700, 5050, and 5515

Under Section 3503 of the California Fish and Game Code, it is unlawful to take, possess, or needlessly destroy the nest or eggs of any bird, except as otherwise provided by this code or any regulation made pursuant thereto. Section 3503.3 of the California Fish and Game Code prohibits take, possession, or destruction of any raptor (birds of prey) in the orders Falconiformes (hawks) or Strigiformes (owls), or of their nests and eggs. Any loss of fertile eggs or nesting raptors, or any activities resulting in nest abandonment, would constitute a significant impact. Project impacts on birds of prey would not be considered "significant" in this EIR unless the species are known or have a high potential to nest on the site or rely on it for primary foraging.

CDFG Fully Protected Species may not be taken or possessed at any time without a permit from CDFG (Sections 3511 birds, 4700 mammals, 5050 reptiles and amphibians, and 5515 fish).

Magnuson-Stevens Fishery Conservation and Management Act

The Magnuson-Stevens Fishery Conservation and Management Act (Magnuson-Stevens Act) (16 U.S.C. Section 1801–1884) of 1976 applies to fisheries resources and fishing activities in Federal waters that extend to 200 miles offshore. Conservation and management of U.S. fisheries,

development of domestic fisheries, and phasing out of foreign fishing activities are the main objectives of the legislation.

The Magnuson-Stevens Act defines “essential fish habitat” as those waters and substrate necessary to fish for spawning, breeding, feeding, or growth to maturity. The Magnuson-Stevens Act, as amended through 2007, sets forth a number of new mandates for NOAA Fisheries, regional fishery management councils, and Federal action agencies to identify essential fish habitat and to protect important marine and anadromous fish habitat. The Magnuson-Stevens Act provided NOAA Fisheries with legislative authority to regulate fisheries in the U.S. in the area between 3 miles and 200 miles offshore and established eight regional fishery management councils that manage the harvest of the fish and shellfish resources in these waters. The councils, with assistance from NOAA Fisheries, are required to delineate essential fish habitat in Fishery Management Plans (“FMPs”) or plan amendments for all managed species. An FMP is a plan to achieve specified management goals for a fishery and is composed of data, analyses, and management measures for a fishery. Essential fish habitat that is identified in an FMP applies to all fish species managed by that FMP, regardless of whether the species is a protected species or not. Federal agency actions that fund, permit, or carry out activities that may adversely affect essential fish habitat are required to consult with NOAA Fisheries regarding potential adverse effects of their actions on essential fish habitat and to respond in writing to NOAA Fisheries’ recommendations. The Central Bay, including the waters surrounding the Islands, is designated as essential fish habitat for fish managed under three FMPs – Pacific groundfish, coastal pelagics, and Pacific coast salmon.¹⁰¹

Rivers and Harbors Appropriations Act of 1899

Section 10 of the Federal Rivers and Harbors Appropriations Act of 1899 (“RHA”) (30 Stat. 1151, codified at 33 U.S.C. Sections 401, 403) prohibits the unauthorized obstruction or alteration of any navigable water (33 U.S.C. Section 403). Navigable waters under the RHA are those “subject to the ebb and flow of the tide and/or are presently used, or have been used in the past, or may be susceptible for use to transport interstate or foreign commerce” (33 C.F.R. Section 3294). Typical activities requiring Section 10 permits are construction of piers, wharves, bulkheads, marinas, ramps, floats, intake structures, cable or pipeline crossings, and dredging and excavation.

Marine Mammal Protection Act

The Marine Mammal Protection Act of 1972 establishes a Federal responsibility for the protection and conservation of marine mammal species by prohibiting the harassment, hunting, capture, or killing of any marine mammal. The primary authority for implementing the Act belongs to the USFWS and NOAA Fisheries.

¹⁰¹ NMFS NWR. 2000. *op. cit.*

California Plant Conservation Program

The legal framework and authority for the State's program to conserve plants is derived from various legislative sources, including CESA, the California Native Plant Protection Act (Fish and Game Code Sections 1900–1913), the *CEQA Guidelines*, and the Natural Communities Conservation Planning Act.

Vascular plants listed as rare or endangered by the CNPS^{102, 103} but which may have no designated status or protection under Federal or State endangered species legislation, are defined as follows:

- List 1A: Plants Presumed Extinct
- List 1B: Plants Rare, Threatened, or Endangered in California and elsewhere
- List 2: Plants Rare, Threatened, or Endangered in California, but more numerous elsewhere
- List 3: Plants About Which More Information is Needed – A Review List
- List 4: Plants of Limited Distribution – A Watch List

In general, plants that appear on CNPS List 1A, 1B, or 2 or have been identified as being of “conservation concern” by the CNPS, are considered to meet the criteria of Section 15380 of the *CEQA Guidelines*, and effects on these species may be considered significant in this EIR. Additionally, plants listed on CNPS List 1A, 1B or List 2 meet the definition of Section 1901, Chapter 10 (Native Plant Protection Act) and Sections 2062 and 2067 (California Endangered Species Act) of the California Fish and Game Code, i.e., that the species is at risk of extirpation).

McAteer-Petris Act

The McAteer-Petris Act (California Government Code, Sections 66600–66682) created the San Francisco Bay Conservation and Development Commission (“BCDC”), which regulates dredging and filling and public access within 100 feet of the mean high tide line within San Francisco Bay. Under the McAteer-Petris Act, BCDC has jurisdiction over all areas of the Bay that are subject to tidal action, including subtidal areas, intertidal areas, and tidal marsh areas that are between mean high tide and 5 feet above mean sea level. In addition, BCDC has jurisdiction over a 100-foot shoreline band surrounding the Bay from the mean high tide line. BCDC's permit jurisdiction does not extend to Federally owned areas, such as the Navy or US Coast Guard property on Yerba Buena Island, because they are excluded from state coastal zones pursuant to the Coastal Zone Management Act. However, with transfer of Naval Station Treasure Island out of Federal control, BCDC permit jurisdiction will apply.

¹⁰² CNPS designations, though frequently used to identify rare plants, are not officially part of State law or policy.

¹⁰³ CNPS. 2009. *op. cit.*

City and County of San Francisco's Urban Forestry Ordinance

The City and County of San Francisco's Urban Forestry Ordinance (Article 16 of the Municipal Code) protects San Francisco's street trees, significant trees and landmark trees regardless of species. It is important to note that this ordinance does not currently apply to the Project Area, because none of the property is under the jurisdiction of the San Francisco Department of Public Works. The three categories of trees protected by the ordinance are defined as follows:

Street trees are "any tree growing within the public right-of-way, including unimproved public streets and sidewalks, and any tree growing on land under the jurisdiction of the Department [of Public Works]" as defined in Section 802 of Article 16 of the SF Tree Ordinance. The removal of street trees by persons other than the Department of Public Works is restricted by Section 806b of Article 16, whereby a permit is required for removal.

Significant trees are defined in Section 810A of Article 16 as trees (1) on property under the jurisdiction of the Department of Public Works or on privately owned-property with any portion of its trunk within 10 feet of the public right-of-way, and (2) that satisfies at least one of the following criteria: (a) a diameter at breast height in excess of 12 inches, (b) a height in excess of 20 feet, or (c) a canopy in excess of 15 feet. The removal of significant trees by persons other than the Department of Public works requires a permit from the Department, according to the process described in Section 806b of Article 16.

Landmark trees are trees that have been nominated as landmark trees by a member of the public, the landowner, the SF Planning Commission, the SF Board of Supervisors, or the Landmarks Preservation Advisory Board, and that have been subsequently designated as a landmark tree by the Urban Forestry Council. Trees that have been nominated and are undergoing review are protected according to the same standards as designated landmark trees while going through the review process, according to Section 810 of Article 16 of the SF Tree Ordinance.

San Francisco General Plan

The following goals and policies related to biological resources protection in the Environmental Protection Element of the *San Francisco General Plan* are relevant to the Project:

General

- Objective 1: Achieve a proper balance among the conservation, utilization, and development of San Francisco's natural resources.
- Policy 1.1: Conserve and protect the natural resources of San Francisco.
 - Policy 1.2: Improve the quality of natural resources.
 - Policy 1.3: Restore and replenish the supply of natural resources.
 - Policy 1.4: Assure that all new development meets strict environmental quality standards and recognizes human needs.

Bay, Ocean and Shorelines

- Objective 3: Maintain and improve the quality of the bay, ocean, and shoreline areas.

Policy 3.1: Cooperate with and otherwise support regulatory programs of existing regional, State, and Federal agencies dealing with the Bay.

Ocean and Shorelines

Policy 3.2: Promote the use and development of shoreline areas consistent with the General Plan and the best interest of San Francisco.

Land

Objective 7: Assure that the land resources in San Francisco are used in ways that both respect and preserve the natural values of the land and serve the best interests of all the City's citizens.

Policy 7.3: Require that filling of land adhere to the highest standards of soils engineering consistent with the proposed use.

Flora and Fauna

Objective 8: Ensure the protection of plant and animal life in the City.

Policy 8.1: Cooperate with and otherwise support the California Department of Fish and Game and its animal protection programs.

Policy 8.2: Protect the habitats of known plant and animal species that require a relatively natural environment.

Policy 8.3: Protect rare and endangered species.

IMPACTS

SIGNIFICANCE CRITERIA

The City and County of San Francisco has not formally adopted significance thresholds for impacts related to biological resources. The Planning Department Initial Study Checklist form provides a framework of topics to be considered in evaluating potential impacts under CEQA. The criteria for biological resources have been modified slightly to accommodate the context of the Islands and the marine environment surrounding them. Implementation of a project would have a potentially significant impact related to biological resources if it were to:

- Have a substantial adverse effect, either directly or through habitat modifications, on any species identified as a candidate, sensitive, or special-status species in local or regional plans, policies, or regulations or by the CDFG, the USFWS, or NOAA Fisheries;
- Have a substantial adverse effect on any riparian habitat or other sensitive natural community identified in local or regional plans, policies, regulations, or by the CDFG or USFWS;
- Have a substantial adverse effect on Federally protected wetlands as defined by Section 404 of the Clean Water Act (including, but not limited to, marsh, vernal pool, coastal, etc.) or "navigable waters" as defined in Section 10 of the Rivers and Harbors Appropriation Act, through direct removal, filling, hydrological interruption, or other means;

- Interfere substantially with the movement of any native resident or migratory fish or wildlife species or with established native resident or migratory wildlife corridors, or impede the use of native wildlife nursery sites;
- Conflict with any applicable local policies or ordinances protecting biological resources, such as a tree preservation policy or ordinance; or
- Conflict with the provisions of an adopted habitat conservation plan, natural community conservation plan, or other approved local, regional, or State habitat conservation plan.

The following sections of the *CEQA Guidelines*, which expand and define some of the terms used in the criteria presented above, were also considered in the impact evaluation:

- *CEQA Guidelines* Section 15065 directs lead agencies to find that a project may have a significant effect on the environment if it has the potential to substantially degrade the quality of the environment, substantially reduce the habitat of a fish and wildlife species, cause a fish or wildlife population to drop below self-sustaining levels, threaten to eliminate a plant or wildlife community, substantially reduce the number or restrict the range of an endangered, rare or threatened species, or eliminate important examples of the major periods of California history or prehistory.
- *CEQA Guidelines* Section 15380 (see “Regulatory Framework,” p. IV.M.35) further provides that a plant or wildlife species, even if not on one of the official lists, may be treated as “rare or endangered” if, for example, it is likely to become endangered in the foreseeable future.

APPROACH TO ANALYSIS

Treasure Island is largely developed and the EIR baseline comprises mainly ruderal (disturbed) habitats and ornamental landscaping. Most vegetation in the area has been introduced as landscape plants and turf grass or consists of weedy, non-native species. Habitats on Yerba Buena Island, with its more natural habitats, would be protected or enhanced. Based upon the significance criteria above, this EIR has determined that the Proposed Project would have no impact on riparian habitats,¹⁰⁴ or wetlands on the Islands protected by the Clean Water Act,¹⁰⁵ and would not conflict with the provisions of any habitat conservation plan or natural community conservation plan.

Construction and operational impacts are considered together in this analysis.

For the purposes of this EIR, the definition of the word “substantial” as used in the significance criteria above has three principal components:

- Magnitude and duration of the impact (e.g., substantial/not substantial);
- Uniqueness of the affected resource (rarity); and

¹⁰⁴ A small area of riparian vegetation occurs on YBI, fed by natural seeps and/or artificial irrigation from leaky pipes. It would not be affected by the Proposed Project.

¹⁰⁵ There are no freshwater wetlands on Treasure Island or Yerba Buena Island. There is a small salt marsh on Yerba Buena Island that would not be affected by the Proposed Project.

- Susceptibility of the affected resource to disturbance.

The evaluation of significance must also consider the interrelationship of these three components. For example, a relatively small magnitude impact on a State or Federally listed species could be considered significant because the species is rare and believed to be very susceptible to disturbance. Conversely, a natural community such as California annual grassland is not necessarily rare or sensitive to disturbance, and thus a much larger magnitude of impact might be required to result in a significant impact. Impacts on biological resources are considered *significant* when project-related habitat modifications (e.g., development, introduction of non-native plant and animal species, increased human intrusion, barriers to movement, or landscape management) could reduce species populations to the extent that they become locally less numerous; impacts on habitats are considered *significant* when the habitats could not continue to support viable populations of associated plant and animal species as a result of project implementation. *Potentially significant* impacts are those that may not be sufficiently reduced through non-discretionary regulatory standards; in those cases, the lead agency would need to implement mitigation measures, where feasible, to reduce the potential level of an impact to less than significant.

This impact analysis is divided into two broad categories: Terrestrial and Offshore. Generally speaking, environmental impacts on biological resources could result from implementing any of the Proposed Project elements described in this EIR, including constructing new infrastructure, streets, buildings, and the proposed open space and wetlands; constructing the new Ferry Terminal on Treasure Island; improving infrastructure; constructing water storage tanks; creating Hilltop Park; and implementing the HMP on Yerba Buena Island.

As mentioned above, implementing the HMP is considered part of the project. Habitat management can temporarily disturb habitat and resident species, but would result in more stable and diverse wildlife and vegetation communities. The HMP includes Best Management Practices (“BMPs”) that would avoid any significant impacts from implementation, and this, together with the long-term benefits of the HMP, support a conclusion that it would not result in any adverse effects on special-status species.

PROJECT IMPACTS

Impact BI-1: The Proposed Project may adversely affect dune gilia and locally significant plants, special status animals, and protected or special-status marine species, such as marine mammals, salmon, steelhead, green sturgeon, longfin smelt, harbor seals and California sea lions. (*Less than Significant with Mitigation*)

This impact is developed for direct and indirect impacts on the organisms themselves. Impacts on intertidal and subtidal marine *habitats* are discussed in more detail in Impacts BI-2, BI-3, BI-4, and BI-6.

Terrestrial

These resources would be potentially exposed to construction-related impacts described in the Project Description and in the HMP. The effects of construction would be generally short term, and would include possible mortality, injury, or physiological stress resulting from site clearance (removal of vegetation), operation of construction equipment on site and vehicle traffic along roads, ground clearance, dewatering activities, and spills of toxic substances. In the post-development period, Treasure Island and Yerba Buena Island would have a higher population that would exert a greater human impact on remaining natural areas and human use of nearshore areas. HMP implementation would involve a variety of measures that would reduce the level of significance including the removal of non-native vegetation (including trees), hand-seeding, hydroseeding, and/or planting container stock, and possible use of pesticides, as well as measures to limit human disturbance of HMP areas.

Dune gilia and locally significant plants. Dune gilia is present in the Project Area on Yerba Buena Island, as are nine other locally significant plant species: California buckeye, California hazelnut, coffee fern, fiesta flower, hollyleaf cherry, maidenhair fern, serpentine springbeauty, wood rose and Vancouver's ryegrass. These plants may be exposed to potentially significant impacts from construction disturbance or the increased population of the Islands. During the operational phase of the project, sites with these plants would be protected by the provisions of the HMP.

Special-status animals. Special-status animals (see below for marine mammals) include American peregrine falcon, double-crested cormorant, and California brown pelican. The existing environment is one of high ambient disturbance due to the proximity of the Bay Bridge and the noise generated there, and, taken together with the fact that no terrestrial habitat for these species would be affected, effects would be less than significant. However, disruption of any of the nesting native birds listed in "Breeding Birds," p. IV.M.18, is not permitted under the MBTA and the Fish and Game Codes. The loss of any active nest (i.e., removing a tree or shrub containing a nest) would be potentially significant. The loss of bats or bat roosts by removing a tree used by bats as a maternal colony would be considered potentially significant.

With implementation of Mitigation Measures M-BI-1a, M-BI-1b, M-BI-1c, and M-BI-1d, to conduct surveys for special-status plants and nesting birds, remove trees and demolish buildings with bat activity at specified times of the year to avoid disturbance, and establish restrictions on off-leash dogs and feeding feral cats, the impacts on terrestrial species identified as rare, threatened, endangered, candidate, sensitive, or other special status by the CDFG or U.S. Fish and Wildlife Service from the Proposed Project would be less than significant. Furthermore, these resources would be protected and enhanced by the HMP implementation measures, including the removal of non-native vegetation and restoring native habitats.

Offshore

Protected or special status marine species and associated critical habitat could be exposed to impacts from the kinds of construction-related disturbances described in Chapter II, Project Description, for improvements along the island's armored shoreline, including installing a new saltwater firefighting system, raising and stabilizing the island's protective shoreline, and consolidating and upgrading stormwater outfalls; onshore demolition and construction; use of temporary barges to remove demolition debris and deliver construction materials; constructing the new Treasure Island Sailing Center boat launch and docking facilities; and construction of a new Ferry Terminal. The potential effects of construction activities on marine biota would range from short-term to permanent, depending on the extent and degree of disturbance and would be expected to result in possible mortality, physical injury, or physiological stress, as would be the situation from habitat loss, increased sedimentation and turbidity, increased exposure to organic and inorganic contaminants in stormwater runoff, and construction noise. In the post-development period, Treasure Island is expected to have a larger resident population and improved public access (including the proposed ferry service from San Francisco) resulting in potential greater human interaction with sensitive marine intertidal habitat and on protected and special status fish species inhabiting the nearshore subtidal areas surrounding the island. Although protected marine species could be affected by all of these potential sources of impacts, those that pose the greatest threat are the Ferry Terminal and Sailing Center construction noise, and exposure to surface runoff contaminants from onshore demolition and construction activities. Other sources of impacts (e.g., initial and periodic maintenance dredging, runoff from a constructed freshwater wetland on Treasure Island) have the potential to affect a broader range of marine biota or sensitive habitat or species and are assessed in Impacts BI-2, BI-3, BI-4, and BI-6, below.

Chinook salmon, Coho salmon, steelhead trout, green sturgeon, and longfin smelt are all inhabitants of the waters surrounding the Islands at some time of the year. The waters surrounding the Islands are identified as critical habitat for winter and spring-run Chinook salmon, Coho salmon, steelhead trout, and green sturgeon. Demolition and construction activities on the Islands could result in extensive ground disturbance, exposing more soil to rainwater runoff, which could result in increased sedimentation and low-level contaminant loading in Bay waters. Potential impacts on protected fish and marine mammal species from increased contaminant loading in Bay waters with low-level contaminated sediments could be significant if uncontrolled. Implementation of normal construction and deconstruction BMPs, such as sediment curtains, use of storm drain covers, and additional street sweeping, to prevent disturbed sediments from reaching storm drains would be expected to reduce these impacts to less-than-significant levels. In addition, specific requirements issued by the RWQCB, San Francisco Region, for stormwater discharges within the City/County of San Francisco in accordance with the new Statewide stormwater permit would contain additional actions to prevent and/or reduce

- Island sediment from reaching Bay waters and causing significant effects on resident offshore biological resources. Additionally, strict adherence to the dredging work windows established by the USACE Long Term Management Strategy (“LTMS”)¹⁰⁶ would be required.

Construction of the Treasure Island Ferry Terminal, with its breakwaters and docks, would involve the installation of pre-cast concrete sheet piles for the breakwaters along with several hundred steel and concrete piles for wingwalls, dolphins, fenders, abutments and over-water building supports. Steel piles would be used for wingwalls, dolphins, and fenders, while concrete piles would be used for abutments and building supports. All sheet piles and concrete and steel pilings would be installed using pile drivers and vibratory hammers that create high decibel noise that can have an effect on protected fish species and marine mammals. In addition, installation of new docks at the Sailing Center on the southeast corner of the Island would involve the installation of additional pilings to anchor floating docks and to support a new pier to support boat launching cranes and support buildings. Both harbor seals and California sea lions use the waters around the Islands for foraging.

Scientific investigations on the potential effect of noise on marine mammals and fish indicate that sound levels below 187 dB do not appear to result in any acute physical damage or mortality in fish; startle responses in steelhead trout and salmon have been documented to occur at sound levels as low as 130 dB at a frequency of 100 Hz and between 180 and 186 dB in Pacific herring.^{107,108} Similar studies on pinnipeds indicate that harbor seals can detect sounds in water as low as 65 dB at 75 Hz and higher^{109,110} and that avoidance behaviors are regularly exhibited at sound levels of 80 dB above hearing thresholds, or approximately 135–160 dB. Kastelan¹¹¹ reported that 12,000 Hz sounds produced a discomfort threshold for harbor seals at 107 dB and that 180 dB sounds at this frequency maintained a discomfort zone at 6.3 kilometers distance. There is the potential for sounds in this frequency to be detected at the harbor seal haul-out on

-
- ¹⁰⁶ U.S. Army Corps of Engineers, LTMS Environmental Work Windows Informal Consultation Preparation Packet, February 2004. <http://www.spn.usae.army.mil/conops/informal.pdf>. Accessed January 2010.
 - ¹⁰⁷ San Luis and Delta Mendota Water Authority and C.H. Hanson, Georgina Slough acoustic barrier applied research project: results of 1994 Phase II field tests. Interagency Ecological Program for the San Francisco Bay/Delta estuary, Technical Report 44, May 1996.#
 - ¹⁰⁸ Dalen, J. and G.M. Knutsen. 1986. Scaring effects of fish and harmful effects on eggs, larvae and fry from offshore seismic explorations. ICA Associated Symposium on Underwater Acoustics, 16-18 July, Halifax, Canada.
 - ¹⁰⁹ Kastak D. and R.J. Schusterman 1998. Low-frequency amphibious hearing in pinnipeds: Methods, measurements, noise and ecology. *J. Acoust. Soc. of Am.* 103 (4), April 1998. 2216-2226
 - ¹¹⁰ Kastak, D., R.J. Schusterman, B.L. Southall and C.J. Reischmuth. 1999. Underwater temporary threshold shift induced by octave-band noise in three species of pinnipeds. *J. Acoust. Soc. Am.* 106 1142-1148
 - ¹¹¹ Kastlein, R.A., S. van der Heul, W. C. Verboom, R. J. V. Triesscheijn, and N.V. Jennings. 2006. *Mar. Env. Res.* 61 (2006). 19-39

IV. Environmental Setting and Impacts
M. Biological Resources

Yerba Buena Island and result in a startle response of resting or feeding seals. To minimize the effect of pile driving sounds on both fish and marine mammals, Mitigation Measure M-BI-1e calls for the use of cushion blocks between the hammerhead and concrete piles to reduce vibration and the use of vibratory hammers to install steel pilings, thereby reducing both sound

level and frequency.¹¹² In addition, where and when necessary to further reduce noise levels to below those known to cause direct physical injury and/or mortality, bubble curtains should be employed.¹¹³

The potential for noise from pile driving to affect normal foraging or resting behaviors in special status fish and marine mammals exists and would be considered a significant impact if not mitigated. Mitigation Measure M-BI-1e calls for on-site monitoring by a qualified marine biologist during pile driving activities as well as other steps to reduce the generation of pile driving noise and to limit its magnitude and transmission to protect marine mammals inhabiting either nearby permanent or temporary haul-outs or transiting near the Development Plan Area are not adversely affected. Mitigation M-BI-1e would also protect special-status fish species such that any potential pile driving noise impacts on special-status fish would be less than significant after mitigation. Other mitigation measures (and extant regulations and permit provisions) for aquatic resources are stipulated in Mitigation Measures M-BI-2, BI-3, BI-4, and BI-6.

Mitigation Measure M-BI-1a: Surveys for Special-Status Plants

On Yerba Buena Island, presence/absence surveys for special-status plants shall be conducted by a qualified botanist prior to any ground disturbance. In the event that special-status plant populations are found during the surveys, the lead agency will avoid disturbance to the species by establishing a visible avoidance buffer zone of not less than 25 feet. If it is not feasible to avoid disturbance or mortality, then special-status plant populations will be restored on-site at a 1:1 ratio in areas that are to remain as post-development open space.

Mitigation Measure M-BI-1b: Pre-project Surveys for Nesting Birds

Pre-project surveys shall be conducted by a qualified biologist for nesting birds between February 1st and August 15th if ground disturbance or tree removal is scheduled to take place during that period. If bird species protected under the Migratory Bird Treaty Act (“MBTA”) or the California Fish and Game Code are found to be nesting in or near any work area, an appropriate no-work buffer zone (e.g., 100 feet for songbirds) shall be designated by the biologist. Depending on the species involved, input from the California Department of Fish and Game (“CDFG”) and/or the U.S. Fish and Wildlife Service (“USFWS”) Division of Migratory Bird Management may be warranted. As recommended by the biologist, no activities shall be conducted within the no-work buffer zone that could disrupt bird breeding. Outside of the

¹¹² ICF Jones & Stokes. 2009. Final Technical Guidance for Assessment and Mitigation of the Hydroacoustic Effects of Pile Driving on Fish Prepared for the California Department of Transportation. Prepared by ICF Jones & Stokes and Illingworth and Rodkin, Inc. February 2009. p. 4-11.

¹¹³ Moffatt & Nichol, *Treasure Island Ferry Terminal Project, Coastal Engineering Assessment*, Prepared for the Water Emergency Transportation Authority, San Francisco, CA, September 14, 2009.

breeding season (August 16 – January 31), or after young birds have fledged, as determined by the biologist, work activities may proceed.

Mitigation Measure M-BI-1c: Minimizing Disturbance to Bats

Removal of trees or demolition of buildings showing evidence of bat activity shall occur during the period least likely to impact the bats as determined by a qualified bat biologist (generally between February 15 and October 15 for winter hibernacula¹¹⁴ and between August 15 and April 15 for maternity roosts). If active day or night roosts are found, the bat biologist shall take actions to make such roosts unsuitable habitat prior to tree removal or building demolition. A no-disturbance buffer of 100 feet shall be created around active bat roosts being used for maternity or hibernation purposes. A reduced buffer could be provided for on a case-by-case basis by the bat biologist, in consultation with CDFG and based on site-specific conditions. Bat roosts initiated during construction are presumed to be unaffected, and no buffer would necessary.

Mitigation Measure M-BI-1d: Control of Domestic and Feral Animals

To avoid conflicts with wildlife on Yerba Buena Island and the remaining natural habitats on Yerba Buena Island, the Islands' Covenants, Conditions and Restrictions, TIDA Rules and Regulations, and/or other similar enforceable instruments or regulations, shall prohibit off-leash dogs outside of designated, enclosed, off-leash dog parks on Yerba Buena Island and the feeding of feral cats on both islands. Building tenants shall be provided with educational materials regarding these restrictions, rules, and/or regulations. Non-resident pet owners and the public using the Islands shall be alerted to these restrictions, rules, and/or regulations through appropriate signage in public areas.

With these mitigation measures in place, in addition to the implementation of a Habitat Management Plan (“HMP”), the potential impacts would be less than significant.¹¹⁵ Measures within the Habitat Management Plan include the removal of non-native vegetation (including trees) in addition to hand-seeding and hydroseeding with native species, and/or planting container stock of native species.

Although non-native plant species are abundant within the Project Area surrounding landscape, the goal of reducing their numbers would help native plants and wildlife. Non-native species would be removed during habitat enhancement related efforts and monitored to ensure against re-establishment within the Project Area.

¹¹⁴ A hibernaculum is a shelter occupied during the winter by a dormant animal.

¹¹⁵ A project is evaluated as a whole, and if it improves habitat in some areas, that effectively reduces the net impact of negative effects.

Mitigation Measure M-BI-1e: Monitoring During Off-Shore Pile Driving

Site-specific conditions during all offshore pile driving shall be monitored by a qualified marine biologist to ensure that aquatic species within the project area would not be impacted, that harbor seals at nearby Yerba Buena Island, at occasional Treasure Island haul-outs, and while in transit along the western shoreline of Treasure Island during work on the Ferry Terminal and in Clipper

Cove during work on the Sailing Center, are not disturbed, and that sound pressures outside the immediate project area do not exceed 160 dB at 500 meters from the source.¹¹⁶ If this threshold is exceeded or avoidance behavior by marine mammals or fish is observed by the on-site marine biologist, bubble curtains will be used to reduce sound/vibration to acceptable levels.

In addition the following measures shall be employed to further reduce noise from pile-driving activities:

- Use as few piles as necessary in the final terminal design;
- Use vibratory hammers for all steel piles;
- Use cushion blocks between the hammer and the pile;
- Restrict pile driving to June 1 to November 30 work window as recommended by NOAA Fisheries to protect herring and salmonids;
- If marine mammals are observed within 1,000 feet of pile driving activities, allow them to completely exit the vicinity of the pile driving activities before pile driving resumes.

Impact BI-2: The project may adversely affect Central Coast Riparian Scrub (riparian habitat), California Buckeye, or SAV/eelgrass beds (other sensitive natural communities). (*Less than Significant with Mitigation*)

Terrestrial

The Islands support riparian vegetation (Central Coast Riparian Scrub on Yerba Buena Island) and one sensitive natural community (California Buckeye Woodland on Yerba Buena Island). By virtue of the HMP for Yerba Buena Island, considered part of the Proposed Project, these areas would be protected and/or enhanced, and no impact is anticipated. Specifically, the HMP describes existing conditions, maps vegetation communities, and makes management recommendations for preservation, restoration, and/or enhancement of native habitats. A section on Best Management Practices in the HMP identifies measures to be taken to minimize potential impacts of plan implementation, including, among others, impacts that could result from recommended actions such as revegetation, fence installation, and invasive species removal.

Offshore

The nearshore Bay waters surrounding Treasure Island support multiple SAV beds including an extensive eelgrass (*Zostera spp.*) bed along the eastern shoreline,^{117,118} a smaller eelgrass bed to the north of the island,¹¹⁹ and red and brown marine algae in the lower rocky intertidal and near

¹¹⁶ This noise/vibration threshold is consistent with the Incidental Harassment Authorization issued to the California Department of Transportation for the East Span of the San Francisco-Oakland Bay Bridge (August 12, 2009).

¹¹⁷ AMS, 2009a. *op. cit.*

¹¹⁸ Merkel & Associates, 2004. *op. cit.*

¹¹⁹ Merkel & Associates, 2004. *ibid.*

subtidal habitat surrounding both Treasure Island and Yerba Buena Island.¹²⁰ These marine aquatic vegetation beds provide critical habitat for Pacific herring (*C. pallasii*) and act as an important habitat and nursery areas for invertebrates such as shrimp and crabs and assorted fish species.¹²¹ In addition, located within the lower intertidal zones of the rocky shoreline surrounding Treasure Island is the native or California oyster. This species is making a significant recovery in the San Francisco Bay-Delta after being considered extinct following over-harvesting in the 1800's, predation by the non-native oyster drill, and pollution.¹²² AMS reported observing native oysters throughout the lower intertidal areas of the island with densities and individual sizes greatest along the west and north shorelines.¹²³

Eelgrass and SAV beds, along with native oysters, would be potentially impacted by proposed improvement work along and adjacent to Treasure Island's armored shoreline including raising and stabilizing the protective shoreline, modifications and changes to the Islands' storm water system and outfalls, increased sedimentation and contaminant loading from onshore demolition and construction, use of temporary barges to remove demolition debris and deliver construction materials, construction of in-water and shoreline Sailing Center facilities, and construction of a new Ferry Terminal. Potential effects would range from short-term to permanent, depending on the extent and degree of disturbance and would be expected to result in possible mortality, physical injury, or physiological stress resulting from reduction in habitat suitability, and physical disturbance/removal.

As discussed above, conformance to new stormwater control regulations and the application of routine construction and deconstruction Best Management Practices (BMPs), such as filter berms, silt fences, straw bales, storm drain inlet protection and vegetated buffers, are expected to constrain any additional sedimentation and movement of potentially contaminated materials through existing and future storm drains; thus, impacts on SAV beds would be less than significant. In addition, Mitigation Measures M-BI-2a and M-BI-2b would restrict all construction activities for geotechnical stabilization of the perimeter berm, renovating the stormwater outfall system, installing piers and dock ramps for the new Sailing Center, and increasing the height of the armored seawall in the lower intertidal and near subtidal zone. All shoreline work would be conducted between the months of March and November, to ensure that redevelopment work along Treasure Island's perimeter berm and rocky shoreline would limit

¹²⁰ AMS, 2009a. *op. cit.*

¹²¹ Merkel & Associates. 2005. *op. cit.*

¹²² Couch, D., and T.J. Hassler, *Species profiles: life histories and environmental requirements of coastal fishes and invertebrates (Pacific Northwest)--Olympia oyster*, U.S. Fish Wildlife Service Biol. Rep. 82(11.124). U.S. Army Corps of Engineers, TR EL-82-4. 8pp.

¹²³ AMS, 2009a. *op. cit.*

IV. Environmental Setting and Impacts
M. Biological Resources

disturbance and result in less-than-significant impacts on sensitive intertidal habitat and associated biota, including nearshore SAV beds. These mitigation measures would act to limit the physical disturbance to these habitats and the sensitive marine communities they support, as well as prevent the loss of SAV and potential Pacific herring spawning substrate. Mitigation Measure M-BI-2c, to survey and avoid eelgrass beds, would

further ensure that any work along Treasure Island's shoreline, as well as the use of barges for delivery of equipment and removal of debris, would result in less-than-significant impacts on SAV beds located around the island and associated Pacific herring spawning substrate and habitat.

Mitigation Measure M-BI-2a: Restriction of Construction Activities

Geotechnical stabilization, shoreline heightening and repair work, stormwater outfall improvements, and other Project activities conducted in and around the Islands' rocky shoreline shall be generally restricted to the terrestrial and upper intertidal zones. Activities in the lower intertidal and near subtidal zone shall be minimized to the maximum extent practicable, using the smallest area and footprint for disturbance as possible. Outside of planned dredging areas (Ferry Terminal and the Sailing Center) movement and disturbance of existing rocks in the lower intertidal zone shall be prohibited.

Mitigation Measure M-BI-2b: Seasonal Limitations on Construction Work

- Construction work on the Islands' shoreline shall be conducted between March 1 and November 30 to avoid any disturbance to herring spawning occurring in SAV surrounding Treasure Island.

Mitigation Measure M-BI-2c: Eelgrass Bed Survey and Avoidance

- Within three to six months of the initiation of construction activities that might affect SAV beds, and not less frequently than biennially (every two years) thereafter, all eelgrass beds shall be surveyed or otherwise identified, including their proximity and potential impact from ongoing or pending onshore or offshore construction activities identified. All TIDA staff in charge of overseeing construction for the Proposed Project, and all construction contractors and subcontractors involved in Project construction activities in Bay waters that are within a quarter mile of Treasure Island and Yerba Buena Island, along Treasure Island's shoreline, or involved in transporting materials and supplies by water to either Island shall be required to undergo thorough environmental training. This training shall present information on the locations of all eelgrass beds, the kinds of construction and vessel transit activities that can impact eelgrass beds, all mitigation measures that contractors must adhere to so that any disturbance or damage to eelgrass beds may be avoided and the beds protected and who to notify in the event of any disturbance. Any work barges or vessels engaged in construction activities shall avoid transiting through and anchoring in any eelgrass beds located around Treasure Island. TIDA personnel responsible for overseeing Project contractors, as well as all Project contractor and subcontractor management personnel, shall ensure that all boat operators and work crews are aware of eelgrass bed locations and the requirement to avoid disturbing them.

Impact BI-3: The project may adversely affect biological resources regulated by the Clean Water Act or the Rivers and Harbors Act. (*Less than Significant with Mitigation*)

Offshore

As discussed above, there are extensive eelgrass beds (*Zostera* spp.) located along most of the eastern shoreline of Treasure Island, to the north of the Island, and across Clipper Cove near the northeast corner of Yerba Buena Island. These beds, which are “Special Aquatic Sites” and regulated under Section 404 of the Clean Water Act, may be adversely affected by shoreline reconstruction and stabilization, removal and installation of new storm drains, construction of the in-water Sailing Center facilities, use of barges to remove demolition debris and deliver construction materials, and discharge from the proposed new wetland. Implementation of Mitigation Measures M-BI-2a through M-BI-2c, discussed above, would reduce potential impacts to less-than-significant levels by limiting the aerial extent and severity of disturbance in the lower

intertidal habitat and nearshore subtidal habitat, and timing of work in the shoreline areas so that eelgrass beds are not disturbed.

Impact BI-4: The project may adversely affect the movement of migratory birds, rafting waterfowl, and/or fish passage. (*Less than Significant with Mitigation for migratory birds and fish passage; Significant and Unavoidable for rafting waterfowl*)

Terrestrial

Avian Collisions with Buildings

Treasure Island is located in the center of San Francisco Bay, and its proximity to significant foraging habitats for at least 500,000 spring migrating shorebirds greatly increases the potential for building collisions.¹²⁴ Proposed multi-story residential and commercial buildings in several areas of Treasure Island could have significant impacts on migratory or resident birds. Regardless of overall height, the ground floor and first few stories of buildings present the greatest hazards to most birds; reflections of attractive ground-level features like vegetation draw birds toward glass surfaces and often result in collisions. Recent increases in the amount of glass surfaces used to better daylight buildings can be considered a “biologically significant” issue, potentially affecting the viability of local and regional bird populations.¹²⁵ Transparent features – especially buildings where birds can see through two glass surfaces to vegetation on the other side – also attract birds and cause collisions. Large, vegetated parks like New York’s Central Park provide valuable stopover habitat for migratory birds in urban areas, and bird strikes are more likely to occur at large buildings near these parks. Open space areas proposed for Treasure Island could create bird habitats in the vicinity of buildings, potentially resulting in higher bird collision risks. At night, many birds are attracted to light and can collide with illuminated buildings, with migratory birds especially vulnerable. While not widely understood, it is thought that many navigation cues for migrating birds include sources of light, such as the stars or the moon. These birds may get confused and disoriented by lit buildings, especially given the distance from Treasure Island to other light sources, rendering them more vulnerable to predation and exhaustion.¹²⁶ Avian collisions are a potentially significant impact.

Implementation of Mitigation Measure M-BI-4a, to require design features such as using patterned or fritted glass and decreasing reflectivity of surfaces, would make buildings appear less transparent. The measure also calls for limiting night lighting, which would reduce the potential

¹²⁴ Stenzel, L.E., C. M. Hickey, J. E. Kjelson, and G. W. Page. 2002. *Abundance and Distribution of Shorebirds in the San Francisco Area*. *Western Birds* 33: 69-98.

¹²⁵ New York City Audubon Society, Bird Safe Building Guidelines, 2007.

¹²⁶ Ogden, L. 1996. Wildlife Damage Management, Internet Center for Fatal Light Awareness Program (“FLAP”). University of Nebraska, Lincoln. <http://digitalcommons.unl.edu/flap/3>. Accessed January 6, 2009.

for disorientation. With this mitigation measure, the impacts on birds from the Proposed Project would be less than significant.

Offshore

Rafting Waterfowl

Increased ferry traffic to and from Treasure Island could have a negative effect on “rafting” (i.e., aggregating on water) bird species. Open waters of San Francisco Bay are essential foraging habitats for many species of resident and migratory birds, and nesting sites are often on shores and rocky cliffs near boat traffic. Many waterfowl species are declining along the West Coast, and human impacts from the heavily urbanized San Francisco Bay Area are often detrimental to them. Rafting birds look, swim, dive, or fly away as watercraft approach them and become distracted from their normal activities.¹²⁷ Increased vigilance and escape behavior reduces their limited energy supply and induces stress. Different species have varying distance tolerances before becoming disturbed, but if disturbed they can be flushed from foraging or resting areas. Diving ducks such as scaup and scoter are especially sensitive to ferry traffic. Long-term effects consist of site abandonment, reduced migration, and reduced reproductive success.^{128,129,130} The Ferry Terminal at Treasure Island would increase ferry traffic in open Bay waters and potentially add to any negative effects. Species on or near Treasure Island that could be affected also include brown pelican, double-crested cormorant, black oystercatcher, western gull, Brandt’s cormorant, and pelagic cormorant. With implementation of Mitigation Measure M-BI-4b, to limit ferry speeds (i.e., lessen the effects of noise and wake) and ferry trips during months of increased waterfowl populations, the impacts on rafting birds from the Proposed Project would be less than significant if the measures are adopted by the responsible agency (see discussion below under Mitigation Measure M-BI-4b). Because adoption of the measure by the responsible agency is not assured and is outside the jurisdiction of the City, the impact on rafting waterfowl is determined to be significant and unavoidable.

Fish and Marine Mammal Passage

Treasure Island’s geographic location in the middle of Central San Francisco Bay forces fish and marine mammals transiting to and from the South Bay to either the Central or North Bay, as well as to the Pacific Ocean, to pass along the Island’s eastern or western shorelines. Construction activities at the proposed Ferry Terminal in the southwest corner of Treasure Island and the

¹²⁷ Huffman, K. 1999. San Diego South Bay survey report – *Effects of Human Activity and Water Craft on Wintering Birds in the South San Diego Bay*. 42 pp.

¹²⁸ Belanger, L. and J Bedard. 1990. *Energetic Cost of Man-induced Disturbance to Staging Snow Geese*. Journal of Wildlife Management 54:36-41.

¹²⁹ Knapton, R. W., S. A. Petrie, and G. Herring. 2000. *Human disturbance of diving ducks on Long Point Bay, Lake Erie*. Wildlife Society Bulletin 28:923-930.

¹³⁰ Mori, Y., N. S. Sodhi, S. Kawanishi, S. Yamagishi. 2001. *The Effect of Human Disturbance and Flock Composition on the Flight Distances of Waterfowl Species*. Journal of Ethology 19:115-119.

Sailing Center along the southeast corner could result in temporary avoidance or a shift in fish and marine mammal movements along either side of the island. Potential Ferry Terminal and Sailing Center construction activities that could cause a change in normal movement behavior include dredging (initial and periodic), increased water turbidity from dredging, and impact hammer noise. Protected marine species potentially affected include harbor seals (*P. vitulina*), California sea lions (*Z. californianus*), Chinook salmon (*O. tshawytscha*), Coho salmon (*O. kisutch*), Steelhead trout (*O. mykiss*), Green sturgeon (*A. medirostris*), and Longfin smelt (*S. thaleichthys*).

Dredging operations would occur during approved USACE Long Term Management Strategy (“LTMS”) dredging windows¹³¹ to avoid important migration periods for salmon, steelhead trout, and green sturgeon, as well as Pacific herring spawning.¹³² Implementation of Mitigation Measure M-BI-1e (pile driving monitoring by a qualified marine biologist and implementation of additional noise reducing practices), as discussed above, is expected to render the transmission of noise from pile driving activities to less than 160 dB at 500 meters distance from the pile driving activity and therein reduce potential effects to all protected fish and marine mammal species to less-than-significant levels.

Mitigation Measure M-BI-4a: Minimizing Bird Strikes

Building Design and Landscaping

- Prior to the issuance of the first building permit for each building in the Proposed Project, project applicants shall have a qualified biologist experienced with bird strikes review the design of the building to ensure that it sufficiently minimizes the potential for bird strikes and report to the Planning Department. The Planning Department may consult with resource agencies such as the California Department of Fish and Game or others, as it deems appropriate.
- The building developer shall provide to the Planning Department a written description of the measures and features of the building design that are intended to address potential impacts on birds, with a copy to TIDA of the final measures approved by the Planning Department or Commission. Building developers are encouraged to coordinate with the Planning Department early in the design process regarding design features intended to minimize bird strikes. The design shall include some of the following measures or measures that are equivalent to, but not necessarily identical to, those listed below, as new, more effective technology for addressing bird strikes may become available in the future:

¹³¹ U.S. Army Corps of Engineers, LTMS Environmental Work Windows Informal Consultation Preparation Packet, February 2004. <http://www.spn.usae.army.mil/conops/informal.pdf>. Accessed January 2010.

¹³² Moffatt & Nichol. 2009. *op. cit.*

IV. Environmental Setting and Impacts
M. Biological Resources

- Employ design techniques that create “visual noise” via cladding or other design features that make it easy for birds to identify buildings as such and not mistake buildings for open sky or trees;

- Decrease continuity of reflective surfaces using “visual marker” design techniques, which techniques may include:
 - Patterned or fritted glass, with patterns at most 28 centimeters apart,
 - One-way films installed on glass, with any picture or pattern or arrangement that can be seen from the outside by birds but appear transparent from the inside,
 - Geometric fenestration patterns that effectively divide a window into smaller panes of at most 28 centimeters, and/or
 - Decals with patterned or abstract designs, with the maximum clear spaces at most 28 centimeters square.
- Up to 40 feet high on building facades facing the shoreline, decrease reflectivity of glass, using design techniques such as plastic or metal screens, light-colored blinds or curtains, frosting of glass, angling glass towards the ground, UV-A glass, or awnings and overhangs;
- Eliminate the use of clear glass on opposing or immediately adjacent faces of the building without intervening interior obstacles such that a bird could perceive its flight path through the glass to be unobstructed;
- Mute reflections in glass using strategies such as angled glass, shades, internal screens, and overhangs; and
- Place new landscapes sufficiently away from glazed building facades so that no reflection occurs. Alternatively, if planting of landscapes near a glazed building façade is desirable, situate trees and shrubs immediately adjacent to the exterior glass walls, at a distance of less than 3 feet from the glass. Such close proximity will obscure habitat reflections and will minimize fatal collisions by reducing birds’ flight momentum.

Lighting

- The Planning Department shall similarly ensure that the design and specifications for buildings on non-Trust property, and TIDA shall ensure that the design and specifications for sports facilities/playing fields and buildings on Trust property, implement design elements to reduce lighting usage, change light direction, and contain light. These include, but are not limited to, the following considerations:
 - Avoid installation of lighting in areas where not required for public safety;
 - Examine and adopt alternatives to bright, all-night, floor-wide lighting when interior lights would be visible from the exterior or exterior lights must be left on at night, including:
 - Installing motion-sensitive lighting,
 - Installing task lighting,
 - Installing programmable timers, and
 - Installing fixtures that use lower-wattage, sodium, and blue-green lighting.
 - Install strobe or flashing lights in place of continuously burning lights for obstruction lighting.

- Use rotating beams instead of continuous light; and
- Where exterior lights are to be left on at night, install fully shielded¹³³ lights to contain and direct light away from the sky, as illustrated in the City of Toronto's Bird Friendly Building Guidelines.¹³⁴

Antennae, Monopole Structures, and Rooftop Elements

- The Planning Department shall ensure, as a condition of approval for every building permit, that buildings minimize the number of and co-locate rooftop-antennas and other rooftop equipment, and that monopole structures or antennas on buildings, in open areas, and at sports and playing fields and facilities do not include guy wires.

Educating Residents and Occupants

- The Planning Department shall ensure, as a condition of approval for every building permit, that the permit applicant agrees to provide educational materials to building tenants and occupants, hotel guests, and residents encouraging them to minimize light transmission from windows, especially during peak spring and fall migratory periods, by turning off unnecessary lighting and/or closing window coverings at night. TIDA shall review and approve the educational materials prior to building occupancy.

Documentation

TIDA shall document undertaking the activities described in this mitigation measure and maintain records that include, among others, the written descriptions provided by the building developer of the measures and features of the design for each building that are intended to address potential impacts on birds, and the recommendations and memoranda prepared by the qualified biologist experienced with bird strikes who reviews and approves the design of the building or sports facilities / playing fields to ensure that it sufficiently minimizes the potential for bird strikes.

Mitigation Measure M-BI-4b: Changes in Ferry Service to Protect Rafting Waterbirds

Waterfowl numbers generally peak in December, with reduced populations during January, and into the spring months. Ferries between San Francisco and Treasure Island shall operate in reduced numbers and slower speeds during December and January; alternatively, during this period ferries, to the extent practicable, shall maintain a buffer zone of 250 meters from areas of high-use by rafting waterbirds.

¹³³ According to the International Dark Sky Association's *Outdoor Lighting Code Handbook* (2000), a fully shielded fixture is "A light fixture constructed in such a manner that all light emitted by the fixture, either directly from the lamp or a diffusing element, or indirectly by reflection or refraction from any part of the luminaire, is projected below the horizontal."

¹³⁴ http://www.toronto.ca/lightsout/pdf/development_guidelines.pdf

Reducing speeds or the number of ferry runs would reduce the overall passenger capacity of this transit mode. Because ferries would operate well below capacity (see Table IV.E.16, p. IV.E.94), implementation of this measure would not result in a significant impact on ferry capacity. To the extent that increased headways or slower trips might discourage ferry use and induce travel by bus or automobiles, this mitigation measure could exacerbate already significant impacts identified in Section IV.E, Transportation. Mitigation Measure M-TR-2, p. IV.E.74, would reduce this impact to less-than-significant levels; however, as stated in Section IV.E, because full funding for the measure is not assured, the impact would remain significant and unavoidable.

In addition, because adoption of this measure by the Water Emergency Transit Authority (“WETA”) is not assured and is outside the jurisdiction of the City, the impact on rafting waterfowl is determined to be potentially significant and unavoidable.

Impact BI-5: The Proposed Project may conflict with local policies or ordinances protecting biological resources, such as a tree preservation policy or ordinance. (*Less than Significant*)

Although the San Francisco Tree Ordinance would not apply to removal of most or all trees on Treasure Island, removal of these trees represents a potential decrease in nesting habitat.¹³⁵ However, many of the trees identified in Table IV.M.4 that would be removed as part of the Proposed Project are not well suited to the site, or are unhealthy, or both. For example, Monterey pines are infected with Pine Pitch Canker, and American sweetgum grow poorly here.¹³⁶ Most of the species proposed for landscaping in the Treasure Island and Yerba Buena Island draft *Design for Development*¹³⁷ have, overall, canopy structure and branching habits similar to the existing trees, and the total quantity and availability of nest sites would not decrease significantly as a result of the Proposed Project. For this reason, and because the San Francisco Tree Ordinance would not apply to removal of trees on Treasure Island and Yerba Buena Island, there would be no conflict with local policies or ordinances protecting biological resources.

¹³⁵ The relevant local policy is *San Francisco General Plan* Policy 8.2: Protect the habitats of known plant and animal species that require a relatively natural environment.

¹³⁶ Barrie D. Coate, arborist, pers. comm., e-mail to Kevin Conger, April 15, 2010.

¹³⁷ Treasure Island Development Authority (TIDA). 2010. *Treasure Island and Yerba Buena Island Design for Development*. Public Review Draft. March 5.

Impact BI-6: The Proposed Project may result in adverse effects on intertidal and subtidal marine habitat and biota located along Treasure Island's shoreline and nearshore regions of the Bay as well as Bay waters. (*Less than Significant with Mitigation*)

Offshore

Impacts BI-2 and 3 address marine habitats as sensitive habitats (BI-2) and regulated wetlands (BI-3). Impact BI-6 addresses broader concerns about habitat quality degradation and issues related to Section 10 of the Rivers and Harbors Appropriation Act.

The proposed Development Program on Treasure Island and portions of Yerba Buena Island, as outlined in Chapter II, Project Description, has the potential to adversely alter intertidal and subtidal marine habitat (including designated Essential Fish Habitat) located along Treasure Island's shoreline and nearshore regions of the Bay as well as Bay waters. These short- and long-term habitat alterations can be expected to affect associated benthic infauna, epifauna, planktonic organisms, and fish inhabiting hard and soft substrate habitats and Bay waters adjacent to the Islands, both during construction activities and during operations of the Proposed Project, and during any regular maintenance activities. Activities that would be expected to alter marine habitat include:

- A temporary, localized decrease of water clarity (increased turbidity) during initial dredging operations for the new ferry basin and Sailing Center, during periodic maintenance dredging of the ferry basin channels and Sailing Center and from propeller wash during ferry operations. Increased turbidity could result in a short-term decrease in phytoplankton and zooplankton production, and reduced fish foraging for resident species including longfin smelt.
- A short-term increase of organic and inorganic contaminant loading to Bay waters from dredging operations effecting contaminant levels in resident biota.
- The permanent loss or replacement of high-energy, coarse sediment, subtidal habitat with lower energy, finer sediment habitat, with concurrent changes in benthic infauna and fish foraging habitat for resident fish species, including protected salmon, steelhead trout, green sturgeon, and Federally managed groundfish from the establishment of the new Ferry Terminal and Sailing Center. A small amount of subtidal soft bottom habitat would be lost under the footprint of the new breakwaters and pilings. Altered subtidal soft bottom habitat would occur not only within the footprint of the new ferry basin but over a larger area of the Bay seafloor approximately one to two times the terminal's footprint. The area of Bay seafloor most affected would be immediately to the south of the terminal, although a small area to the north of the Ferry Terminal's north breakwater would also be altered as a result of altered wave and current energy resulting from the terminal breakwaters.¹³⁸ At the Sailing Center the infaunal benthic habitat and associated biological community is expected to return to comparable composition and productivity shortly after dredging.
- A permanent increase in nighttime illumination over Bay waters immediately adjacent to Treasure Island from street lighting along the shoreline walkways, dock lighting at the

¹³⁸ Moffatt & Nichol, 2009, *op. cit.*

Ferry Terminal and the Sailing Center, and from multi-story buildings on the Island. Increased night illumination can alter normal fish behavior and increase bird, fish, and marine mammal predation on some fish species.

- A permanent reduction in species diverse rocky intertidal habitat at the location of the new Ferry Terminal. Portions of the shoreline at the new Ferry Terminal would be replaced with a vertical concrete or other material bulkhead with reduced habitat area and potential diversity in associated intertidal biota.
- The permanent addition of vertical hard substrate and associated attached epibenthic communities from pilings, vertical breakwaters, floating docks, and dolphins at the new Ferry Terminal and Sailing Center.
- The permanent shading and decreased light penetration of Bay waters under and adjacent to floating docks and breakwaters at the new Ferry Terminal and Sailing Center. Shading can result in decreased phytoplankton production and growth of SAV such as eelgrass.
- The potential long-term increase of methyl mercury contaminant loading to Bay waters and marine biota, including protected fish species, if methyl mercury contaminated water and/or wetland-originated biota is discharged from the new wetland located on Treasure Island.
- The short-term or long-term impact to intertidal, subtidal, and pelagic habitat and associated marine biota from an accidental fuel spill from new ferry operations.

These potential temporary or permanent alterations to marine habitat and associated marine biota are expected to be, or can be, reduced to less-than-significant levels with the application of Mitigation Measures M-BI-2a through M-BI-2c, above, or in the LTMS guidelines and requirements, as described below.

Increased turbidity from dredging operations would be short-term, occurring only during initial dredging operations to build the Ferry Terminal and the Sailing Center launch facilities and occasionally thereafter during maintenance dredging operations. Initial dredging of the ferry basin is expected to take 1 to 2 months. The Sailing Center area is expected to take substantially less time. Maintenance dredging is estimated to occur on an annual or biannual basis depending on the rate of sediment deposition.¹³⁹ All dredging activities would comply with USACE and Regional Water Quality Control Board regulations and provisions in issued permits concerning the control of increased sediment turbidity from dredging operations. The high energy waves and currents present along the western shoreline of Treasure Island can be expected to quickly dissipate any turbidity plumes generated from dredging operations and minimize any effect to marine habitats and biota. The proposed dredging for the new ferry basin is consistent with routine maintenance and new channel/harbor dredging conducted throughout the Bay annually and evaluated in the development of the LTMS for dredging in San Francisco Bay. Dredging volumes from the Sailing Center launch facilities would be 10 percent less than those for the Ferry Terminal. Adherence to the guidelines and dredging requirements outlined in the LTMS

¹³⁹ Moffatt & Nichol. 2009. *ibid.*

relative to the increased turbidity in highly localized turbidity plumes and its potential effect on marine biota are considered less than significant.¹⁴⁰

Increased turbidity from propeller wash during ferry operations would be permanent and continuous during active ferry operations and is estimated to remain within the confines of the Ferry Terminal breakwaters.¹⁴¹ The actual increase in turbidity that would occur within the Ferry Terminal from prop wash is unknown and would be determined by the composition of the new marine sediments composing the seafloor within the ferry basin. Bay waters are normally turbid, and the increase from prop wash may or may not be detectable and may or may not have an effect on plankton productivity. However, the potential slight increase in water turbidity and decreased plankton productivity within the approximately 0.004 square mile of surface water contained within the proposed ferry basin, when compared to the 479 square miles of water within the Bay (which undergoes regular fluctuations in turbidity from vessel movements, stormwater inflow, and wind generated wave action), support a conclusion that the impact of propeller wash on Bay plankton productivity would be less than significant.

The presence of organic or inorganic contaminants in nearshore sediments that would be dredged at the proposed Ferry Terminal site is unknown. As part of the Navy's decommissioning of the Island, scientific assessments were conducted throughout the Island in order to identify areas requiring remediation. The proposed Ferry Terminal site was not identified by the U.S. Navy as a location requiring remediation.¹⁴² The proposed Sailing Center launch facilities are outside the Site 27 area in Clipper Cove identified as contaminated with lead and heavy metals (see Figure IV.P.1: Installation Restoration Site Inventory, in Section IV.P, Hazards and Hazardous Materials, p. IV.P.10). As part of the permitting process for dredging these sediments, representative samples are required to be collected for contaminant analysis in order to determine proper dredging and disposal procedures and to minimize potential contaminant spread and loading to the Bay and its biological resources. If organic or inorganic contaminants are discovered as a result of sampling, adherence to the required dredging and disposal procedures (e.g., use of silt curtains, upland disposal) would ensure that any potential impact from the resuspension of organic or inorganic contaminants from dredging is expected to be less than significant.

The construction and operation of the new Ferry Terminal at Treasure Island would result in the loss of coarse sediment, higher-energy, benthic habitat and associated biological community

¹⁴⁰ LTMS Agencies. (1998). Long-Term Management Strategy (LTMS) for the Placement of Dredged Material in the San Francisco Bay Region, *Final Policy Environmental Impact Statement/Programmatic Environmental Impact Report*, Volume I.

¹⁴¹ Moffatt & Nichol, 2009. *op. cit.*

¹⁴² U.S. Navy, Environmental Cleanup Program Former Naval Station Treasure Island Fact Sheet, Volume 4 - August 2007.
<http://www.sftreasureisland.org/Modules/ShowDocument.aspx?documentid=71>. Accessed January 2010.

within the footprint of the terminal and to the immediate north and south of the terminal breakwaters.¹⁴³ Seafloor habitat immediately under the breakwater structures would be lost completely but would represent a small area of the Bay, since concrete sheet piling is proposed for breakwater construction with minimal rock rip rap.¹⁴⁴ The seafloor habitat within the Ferry Terminal and shore side of both the north and south breakwaters would change to a lower energy, depositional, finer sediment habitat with a similar shift in marine biota.¹⁴⁵

Altering benthic habitat and associated infaunal and epifaunal communities can result in the loss or reduction of suitability as fish foraging habitat, especially for protected species. The waters around Treasure Island are identified as critical habitat for Chinook salmon, Coho salmon, steelhead trout, green sturgeon, and longfin smelt. Of these species, the one potentially most affected by this alteration in benthic habitat is the green sturgeon. Green sturgeons are known to feed upon opossum shrimps (*Neomysis mercedis* and *N. awatchensis*), the amphipod *Corophium*, annelid worms, the bay shrimp *Crangon franciscorum*, the isopod *Synidota liticsud*, the Asian clam *Corbula amurensis*, and the gastropod *Olivella baetica*.¹⁴⁶

The current benthic community along the west side of the Treasure Island is characterized by the seapen (*Stylatula elongata*), the bivalve *Rocheforta coani*, the polychaetes, *Ameana occidentalis*, *Mediomastus* spp., and *Euchonia limnicola*, and the amphipod, *Ampelisca abdita*.¹⁴⁷ After construction of the Ferry Terminal, affected seafloor habitat is expected to shift to a finer sediment, depositional environment, identified within San Francisco Bay as Marine Muddy.¹⁴⁸ This benthic community associated with this habitat is characterized by the polychaetes *Euchone limnicola* and *Mediomastus* spp. and six species of amphipods, including *Corophium heteroceratum*, *C. acherusicum*, *C. insidiosum*, *C. spp.* *Photis* spp., *Ampelisca abdita*.¹⁴⁹ Shifting from a coarser to finer sediment benthic habitat appears to increase the presence of potential species (*Corophium* spp.) upon which the protected green sturgeon prey, and is therefore expected to result in a less-than-significant impact. Any shift in benthic community composition also would not be expected to have a significant impact on other protected fish species, including salmon, steelhead, and smelt. Similarly, although no benthic survey was conducted in the region of the proposed Sailing Center, observations made during the AMS intertidal survey at extreme

¹⁴³ Moffatt & Nichol, 2009. *op.cit.*

¹⁴⁴ Moffatt & Nichol, 2009. *ibid.*

¹⁴⁵ Moffatt & Nichol, 2009. *ibid.*

¹⁴⁶ EPIC, Petition to List the North American Green Sturgeon (*Acipenser medirostris*) as an endangered or threatened species under the endangered species act, prepared by the Environmental Protection Information Center, The Center for Biological Diversity, and Waterkeepers Northern California, June 2001.

¹⁴⁷ AMS, 2009b. *op. cit.*

¹⁴⁸ Thompson, B., Lowe, S. & Kellogg, M. 2000. *Results of the Benthic Pilot Study 1994-1997, Part 1—Macrobenthic Assemblages of the San Francisco Bay-Delta, and their Responses to Abiotic Factors*. Technical Report 39. San Francisco Estuary Institute, Oakland, CA. August 2000.

¹⁴⁹ Thompson et al. 2000. *ibid.*

low tides reported the lower intertidal region of this area of Treasure Island to be composed of finer sediments.¹⁵⁰ As such it can be assumed to support a benthic infaunal community comparable to Marine Muddy, as described above.¹⁵¹ Following dredging, this benthic community is expected to recover to pre-dredging compositions and therefore also not result in any significant impact.

Increased artificial illumination of Bay waters at night can alter normal swimming and foraging behavior of fish, marine mammals, and seabirds. Many pelagic schooling fish, such as sardines and herring are attracted to illumination cast by boats and offshore structures and are frequently subject to increased predation from other fish species as well as marine birds and occasional marine mammals. Typical and customary use of low-voltage, sodium, and blue-green spectrum lights, as well as appropriate placement and shielding of lights to prevent or reduce night illumination of Bay waters, as specified in Mitigation Measure M-BI-4a to prevent impacts to birds, would also reduce lighting impacts to marine biota to a less-than-significant level.

The creation of a Ferry Terminal along Treasure Island's southwest shore is estimated to result in the loss of less than 100 feet of rocky intertidal shoreline and the introduction of approximately 2,000 to 3,000 linear feet of vertical concrete surface along the shoreline bulkhead and breakwaters in the upper and middle intertidal zones. No loss of intertidal or near subtidal habitat at the Sailing Center is expected to occur. In addition, the numerous concrete and steel pilings and floating dock surfaces from both projects would create vertical hard substrate surfaces that are not substantially present in the nearshore area along either the southeastern or western shoreline of Treasure Island where the Ferry Terminal is proposed for construction. The marine biota expected to inhabit these artificial hard substrate habitats would consist of many of the same species inhabiting the existing middle and lower rocky intertidal and near subtidal habitats along the western shoreline of Treasure Island and Yerba Buena Island including barnacles (*Balanus spp.*), mussels (*Mytilus spp.*) encrusting diatoms, sponges, bryozoans, tunicates, and assorted red and green algae. It is anticipated that the species diversity and abundances inhabiting the vertical concrete breakwaters and bulkheads and the assorted pilings and floating docks would be similar to that present along the western shoreline of Yerba Buena Island¹⁵² where the abundant crevices and protected spaces present in the piled rock rip rap along Treasure Island's shoreline were not present. As a result, the intertidal and near subtidal area observed along the western shoreline of Yerba Buena Island were slightly less diverse and lower in individual species abundances. The slightly higher species diversity and abundances at Treasure Island were attributed to the increased surface area and protected habitat created by the rock piles with multiple crevices.¹⁵³ The estimated loss of less than 100 feet of lower and middle rocky intertidal hard substrate would

¹⁵⁰ AMS. 2009a. *op. cit.*

¹⁵¹ Thompson et al. 2000. *op. cit.*

¹⁵² AMS. 2009a. *op. cit.*

¹⁵³ AMS. 2009a. *ibid.*

be offset by the creation of more than 2,000 to 3,000 feet of vertical hard substrate relief that would be colonized and inhabited by the same epifaunal species, as well as provide habitat for additional species more adaptive to vertical relief exposure. The very small amount of lower and middle rocky intertidal substrate and biota lost to the construction of the new Ferry Terminal and the addition of more than 3,000 feet of new hard substrate habitat that can be inhabited by the same flora and fauna would, thus, result in a less-than-significant impact. Similarly, since no intertidal and only incidental subtidal habitat would be affected at the Sailing Center, the impact is considered to be less than significant.

The establishment of docks, pilings, and breakwaters at the new Ferry Terminal and Sailing Center has the potential to reduce light penetration into Bay waters as a result of shading. This shading and decreased light penetration could reduce phytoplankton productivity and the growth of SAV, including eelgrass. As discussed previously, the regular movement of ferryboats into and out of the new Ferry Terminal could be expected to increase the natural turbidity of the waters within the basin's breakwaters. This increased turbidity from propeller wash would hinder the penetration of light and keep fine seafloor sediments in a constant state of disturbance and suspension. Phytoplankton production in the waters within the ferry basin is not anticipated to be very high nor to substantially affect the Bay's overall primary productivity. As a result, the effects of shading on phytoplankton production would be less than significant.

The seafloor sediments within the ferry basin, as discussed above, would become finer in texture, as well as be maintained in a constantly disturbed state from ferryboat propeller wash. The establishment of SAV beds, especially eelgrass, is highly unlikely¹⁵⁴ and therefore any effects of shading on SAV beds would be less than significant.

The creation of a large self-sustaining freshwater wetland on Treasure Island, as part of the stormwater treatment system and tertiary level wastewater treatment system, has the potential to generate methyl mercury which would be expected to be discharged to Bay waters through the wetland's discharge to the Bay. Treasure Island was constructed of dredged Bay sediments, which, as a result of historic gold and mercury mining in the watersheds flowing into San Francisco Bay, contains elevated concentrations of mercury.¹⁵⁵ The presence of mercury in Bay

¹⁵⁴ Merkel & Associates. 2004. *op. cit.*

¹⁵⁵ Tetra Tech, Inc. 2006. *Conceptual Model of Mercury in San Francisco Bay*, prepared for the Clean Estuary Partnership, January 16, 2006.

sediments has resulted in a 303d listing by the RWQCB.¹⁵⁶ Wetland sediments typically are subject to hypoxic (reduced oxygen) conditions, which can facilitate the conversion of mercury present in the sediment to methyl mercury, a bioavailable form.¹⁵⁷ Such conditions are found in wetlands in nature throughout the Bay. This process generally occurs in the upper 2 to 10 centimeters of sediments as a result of microbial degradation and benthic bioturbation.¹⁵⁸ Photodemethylation¹⁵⁹ is also known to occur within the water column as a result of solar radiation penetrating the water.¹⁶⁰ Water mixing and turbidity can be expected to reduce the amount of photodemethylation that occurs. Methyl mercury is water-soluble and, if present, would be expected to be released into Bay waters when water is discharged from the planned wetland.

Additionally, the bioaccumulation of methyl mercury by flora and fauna residing in the wetland can result in the direct transport of bioavailable mercury to Bay consumers and predators. This pathway of methyl mercury into Bay waters, via mobile prey, potentially would pose an additional risk to Bay fauna, especially top predators resident near or feeding within proximity to the wetland discharge into the Bay.

Untreated methyl mercury released into the Bay from discharged water or mobile biota from the wetland, would be expected to increase the loading of methyl mercury in the Bay. This increased loading could have a detrimental effect on Bay biota, including protected fish, birds and marine mammals and would further exacerbate mercury impairment of the receiving waters. The RWQCB has revised the Basin Plan for San Francisco Bay to include revised controls on mercury concentrations in discharges to the Bay.¹⁶¹ As such, compliance with applicable RWQCB regulations¹⁶² and NPDES permits would ensure that the construction of the wetlands would be

¹⁵⁶ Section 303(d) of the 1972 Federal Clean Water Act requires states to identify waterbodies that do not meet water quality objectives and are not supporting their beneficial uses. Each state must submit an updated list, called the 303(d) list, to the U.S. EPA every two years. In addition to identifying the waterbodies that are not supporting beneficial uses, the list also identifies the pollutant or stressor causing impairment, and establishes a priority for developing a control plan to address the impairment. The list also identifies waterbodies where: (1) a TMDL has been approved by U.S. EPA and an implementation is available, but water quality standards are not yet met, and (2) waterbodies where the water quality problem is being addressed by an action other than a TMDL and water quality standards are not yet met.

¹⁵⁷ Tetra Tech, Inc. 2006. *ibid.*

¹⁵⁸ Fenchel, T., "Worm Burrows and Oxidic Microniches in Marine Sediments, 1. Spatial and temporal scales," *Marine Biology*, Volume 127 (2), pp. 289-295, 1996.

¹⁵⁹ Photodemethylation is the breakdown of methyl mercury, the biologically available form of mercury, in water via sunlight.

¹⁶⁰ Tetra Tech, Inc. 2006. *ibid.*

¹⁶¹ Regional Water Quality Control Board, "Mercury in San Francisco Bay, Proposed Basin Plan Amendment and Staff Report, Revised Total Maximum Daily Load (TMDL) and Proposed Mercury Water Quality Objectives," Final Staff Report, California Regional Water Quality Control Board, San Francisco Region. 2008.

¹⁶² RWQCB. 2008. *ibid.*

designed and executed in a manner that limits or prevents the generation of any methyl mercury and would result in a less-than-significant impact.

The operation of a new Treasure Island ferry service would increase the risk of accidental oil spills to Bay waters from leaks or breaks in vessel fueling equipment, vessel collisions or sinkings, mechanical or structural failures, or simple human error resulting from the additional ferry vessels and transits between San Francisco and Treasure Island and between the ferry docks and the fueling station. Any release of fuel oil or diesel to the Bay would have the potential for a significant impact to Bay habitats and associated marine biota, including protected fish and marine mammal species and sensitive habitats such as eel grass beds and wetlands. The potential effect of fuel oil spills from existing and future ferry operations is addressed in the Water Quality Section (Section 3.4.1.7) of the *Final Program Environmental Impact Report for Expansion of Ferry Transit Service in the San Francisco Bay Area*, dated June 2003. This EIR determined that after implementation of mitigation measures W-3.1 through W-3.5 – which include strengthening the San Francisco Harbor Safety Plan, regularly updating oil spill response and contingency plans, providing training for personnel responsible for fueling vessels, and using anti-fuel spill technological improvements in new ferry vessels – that the risk to Bay waters and associated marine biota was less than significant.¹⁶³ As was done by WETA for other WETA projects, such as the South San Francisco Ferry Terminal Project, it is expected that WETA would implement these mitigation measures in operating the Treasure Island ferry service, and no further mitigation would be required.¹⁶⁴

CUMULATIVE IMPACTS

Impact BI-7: The development planned as part of the Proposed Project, when combined with past, present, and other reasonably foreseeable development in the vicinity, could result in significant cumulative impacts to biological resources. (Cumulative Impact: Significant and Unavoidable for rafting waterfowl; Less than Significant for other sensitive plants, animals and habitats)

The geographic scope of potential impacts on biological resources encompasses the sensitive habitats within the Project Area as well as biologically linked areas sharing the Central Bay and its waters. The EIR evaluates the impacts of the Proposed Project on biological resources, and presents mitigation measures that would support a conclusion of less than significant, with mitigation, for all impacts on biological resources except rafting waterfowl. Impacts on rafting waterfowl would remain significant and unavoidable because enforcement of

¹⁶³ Water Emergency Transportation Authority, *Final Program Environmental Impact Report Expansion of Ferry Transit Service in the San Francisco Bay Area*, June 2003, pp. 3.4-10 to 3.4-22. This information is incorporated by reference and summarized in the text above.

¹⁶⁴ John Sindzinski, Manager of Planning, Water Emergency Transit Authority, personal communication, April 19, 2010; and the *South San Francisco Ferry Terminal Project Final EIR/EA*, November 27, 2006, State Clearinghouse No. 2004122091, and its Mitigation Monitoring and Reporting Program.

proposed mitigations is beyond the authority of the Lead Agency. Implementation of the Habitat Management Plan for Yerba Buena Island would provide biological improvements and additional protection for sensitive resources.

Other foreseeable projects on the Islands include the proposed Yerba Buena Island/I-80 Interchange Project and the construction and operation of a 400-berth marina in Clipper Cove, may have similar effects on biological resources. However, these projects would be required to comply with the same regulatory framework as the Proposed Project. For example, the Yerba Buena Island/I-80 Interchange Project, currently under consideration by Caltrans and the San Francisco County Transportation Authority (“SFCTA”), could impact stinging phacelia (a sensitive plant); however, compensation (plant relocation or seeding) would likely be required at a minimum 1:1 ratio. As part of that project, SFCTA and Caltrans are also considering improvements to the existing Yerba Buena Island viaduct that links the Bay Bridge to the Treasure Island Causeway. These improvements would strengthen the bridge substructure and modify the superstructure and would be subject to similar mitigation standards. As indirect effects, these projects would result in increased human activity on Yerba Buena Island, but because the Proposed Project would comprise the majority of that increase, and could be fully mitigated, there would be minimal contribution to cumulative impacts.

Off-island, there could be cumulative impacts on sensitive biological resources located throughout the Central Bay when the impacts of the Proposed Project are considered in combination with the impacts of other projects in the vicinity. Many of these are habitat improvement projects (see for example the list of projects compiled by the San Francisco Bay Restoration Authority at <http://www.sfbayrestore.org.pdf>) that are intended to provide a net benefit to biological resources and would not contribute to long-term, adverse cumulative impacts on sensitive species and habitats. However, expanded ferry or water taxi services, such as the service described in the *Berkeley Albany Ferry Terminal Study Draft EIS/EIR*, are expected to contribute, along with the Proposed Project, to a cumulatively significant and unavoidable impact on rafting waterfowl.

N. GEOLOGY AND SOILS

This section describes geologic and seismic conditions of the Project Area and its vicinity and evaluates the potential for the Proposed Project to result in significant impacts related to exposing people or structures to substantially adverse geologic hazards, soils, and/or seismic conditions. There have been numerous geologic and geotechnical investigations of the Development Plan Area and its vicinity, but this analysis relies primarily on the Geotechnical Conceptual Design Reports prepared for both Treasure Island and Yerba Buena Island by Engeo Incorporated.¹ Potential impacts are discussed and evaluated, and appropriate mitigation measures are identified where necessary.

SETTING

TOPOGRAPHY

There are distinct differences in topography between the Islands. Treasure Island is relatively flat with little topographic relief. Surface elevations at Treasure Island range from approximately 6 to 14 feet (all elevations are based on North American Vertical Datum of 1988). Yerba Buena Island rises to a maximum elevation of approximately 350 feet with steep slopes along the perimeter of the island that range from 1.5:1 to 1:1 (horizontal:vertical). The western and southern perimeters of Yerba Buena Island have lower slopes that are characterized by wave-cut bluffs that expose the underlying bedrock. Development on Yerba Buena Island has altered some of the original topography. The causeway used for access to Treasure Island begins at an elevation of approximately 55 feet and slopes toward the north down to approximately 13 feet. The eastern and western edges of the causeway are characterized by steep slopes that are protected in areas with rock or rip-rap.

REGIONAL GEOLOGY

The Project Area lies within the geologically complex region of California referred to as the Coast Ranges geomorphic province.² The Coast Ranges province lies between the Pacific Ocean and the Great Valley (Sacramento and San Joaquin Valleys) provinces and stretches from the Oregon border to the Santa Ynez Mountains near Santa Barbara. Much of the Coast Range province is composed of marine sedimentary deposits and volcanic rocks that form northwest-trending mountain ridges and valleys, running subparallel to the San Andreas Fault Zone. The relatively thick marine sediments dip east beneath the alluvium of the Great Valley.

¹ Engeo, Incorporated, *Geotechnical Conceptual Design Report, Yerba Buena Island, San Francisco*, November 21, 2008; and *Geotechnical Conceptual Design Report, Treasure Island, San Francisco*, February 2, 2009, in *Treasure Island Infrastructure Update*, Appendix C.

² A geomorphic province is an area that possesses similar bedrock, structure, history, and age. California has 11 geomorphic provinces.

The Coast Ranges can be further divided into the northern and southern ranges, which are separated by the San Francisco Bay. San Francisco Bay lies within a broad depression created from an east-west expansion between the San Andreas and the Hayward fault systems.

The Northern Coast Ranges are composed largely of the Franciscan Complex or Assemblage, which consists primarily of graywacke, shale, greenstone (altered volcanic rocks), basalt, chert (ancient silica-rich ocean deposits), and sandstone that originated as ancient sea floor sediments. Franciscan rocks are overlain by volcanic cones and flows of the Quien Sabe, Sonoma and Clear Lake volcanic fields.³

SITE GEOLOGY

The geologic conditions within the Project Area vary greatly between the two Islands. Treasure Island was largely created through the placement of fill over a natural sand shoal or sand spit. Sand was dredged from various areas in San Francisco Bay and hydraulically placed within a series of rock dikes. The rock dikes were originally placed on top of the dredged sand in most areas of Treasure Island, or on top of the sand shoal in the southwest corner of the island. In the northern corner of Treasure Island, the dredged sand was placed directly on top of soft estuarine deposits known as Young Bay Mud.

There are six different geologic units that underlie Treasure Island:

- Sand Fill and Shoal Sands: The dredged materials that were imported onto the site consisted of various sands with varying amounts of silt, clay, and small gravels. The thicknesses of the sand fill and shoal sands vary between approximately 30 and 50 feet.
- Young Bay Mud: Soft compressible clays with occasional interbedded sand layers. Thicknesses vary from 20 to 120 feet with the greatest thicknesses found in the northwest corner of the island. There is also a thick layer of Young Bay Mud in the southeast corner of the island.
- Merritt-Posey-San Antonio (“MPSA”) Sands and Clays: This combined unit of sand and clay layers, which separates the Young Bay Mud from the Old Bay Mud, has not been well characterized on Treasure Island. However, it has been extensively studied for the new east span of the Bay Bridge, nearby. The dense to very dense sands and very stiff clays vary in thickness from point to point but are absent in the areas where Young Bay Mud is thickest.
- Old Bay Mud: The older clays known as Old Bay Mud underlie the MPSA and are indistinguishable from another geologic unit known as the Upper Alameda Formation. These very dense sands and hard clays are the deepest unconsolidated materials encountered before reaching bedrock. Bedrock at Treasure Island is encountered approximately 285 feet below ground surface.

³ California Geological Survey, *California Geomorphic Provinces*, CGS Note 36, 2002.

- **Franciscan Formation:** Also referred to as Franciscan Complex, this collection of interbedded graywacke sandstone, siltstone, and shale have been heavily altered by tectonic forces.⁴

At various locations on Yerba Buena Island imported fill material was used as part of some of the development on the island, but the amount is very minor relative to what is found on Treasure Island. Other geologic materials include dune sand and alluvium, which are unconsolidated and derived from wind-blown and marine terrace deposits, colluvium, landslide debris, and Franciscan Complex bedrock.⁵

Soils

Because Treasure Island was created by imported fill materials, there are no native surface soils on the island. Surface soils consist of imported dredged materials, primarily sands with some small gravels, silt, and clay. Surface soils on Yerba Buena Island include sand and rock fragment mixtures from local sources or dredge spoils. Dredge spoils and possible excavated materials from the Bay Bridge tunnel are found along the Bay margins, and sand and rock fragment mixtures are typically found in upland areas under building pads and roadways. Other surface soils include sandy colluvium and wind-blown sands.

SEISMICITY

The Proposed Project lies within a region of California that contains many active and potentially active faults and is considered an area of high seismic activity (see Figure IV.N.1: Regional Fault Map).⁶ The 2007 Working Group on California Earthquake Probabilities, which was formed by the U.S. Geological Survey (“USGS”) along with the California Geological Survey (“CGS”) and the Southern California Earthquake Center, has evaluated the probability of one or more earthquakes of magnitude 6.7 or higher occurring in California over the next 30 years. The result

⁴ Tectonics refers to the broad architecture of the outer part of the Earth’s crust and the regional assembling of its structural and deformational features such as faulting and folding.

⁵ Colluvium is a general term applied to any loose mass of soil and rock materials typically deposited by rainwater runoff or downslope creep and found at the base of a slope.

⁶ An “active” fault is defined by the State of California as a fault that has had surface displacement within Holocene time (approximately the last 11,000 years). A “potentially active” fault is defined as a fault that has shown evidence of surface displacement during the Quaternary (last 1.6 million years), unless direct geologic evidence demonstrates inactivity for all of the Holocene or longer. This definition does not, of course, mean that faults lacking evidence of surface displacement are necessarily inactive. “Sufficiently active” is also used to describe a fault if there is some evidence that Holocene displacement occurred on one or more of its segments or branches. (Source: Hart, E. W., Fault-Rupture Hazard Zones in California: Alquist-Priolo Special Studies Zones Act of 1972 with Index to Special Studies Zones Maps, California Division of Mines and Geology, Special Publication 42, 1990, revised and updated 1997).

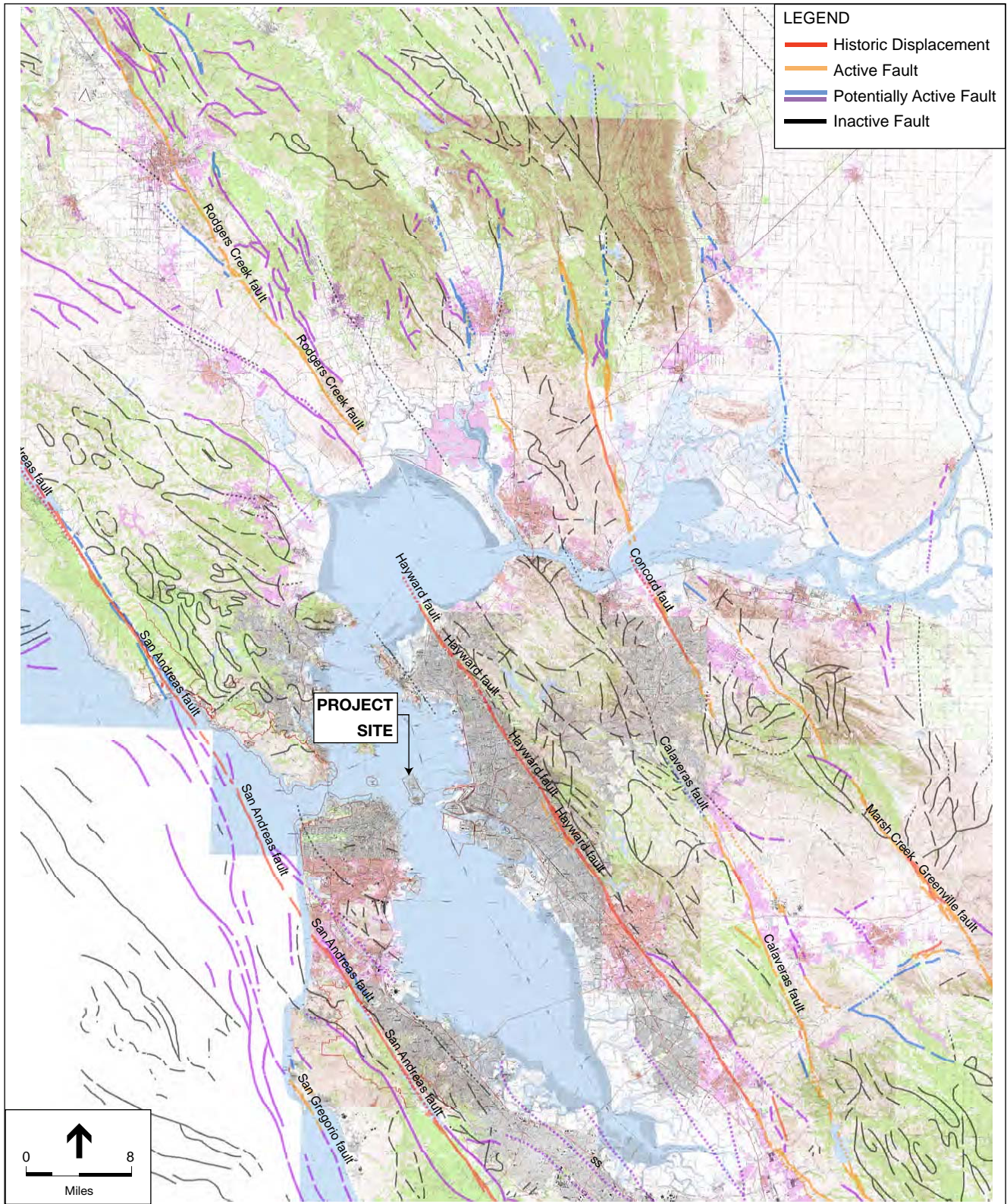

SOURCE: Jennings, 1994

NOTE: Fault lines indicated by solid lines where well located, dashed where approximate, and dotted where concealed.

of the evaluation indicated a 63 percent likelihood that such an earthquake event would occur in the Bay Area.⁷

Richter magnitude (“M”) is a measure of the size of an earthquake as recorded by a seismograph, a standard instrument that records ground shaking at the location of the instrument. The reported Richter magnitude for an earthquake represents the highest amplitude measured by the seismograph at a distance of 100 kilometers from the epicenter. Richter magnitudes vary logarithmically, with each whole number increase representing a ten-fold increase in the amplitude of the recorded seismic waves. Earthquake magnitudes are also measured by their Moment Magnitude (“Mw”), which is related to the physical characteristics of a fault, including the rigidity of the rock, the size of fault rupture, and movement or displacement across a fault.⁸ A maximum moment magnitude earthquake represents a calculated estimate of what moment magnitude earthquake could occur in the future.

Ground movement during an earthquake can vary depending on the overall magnitude, distance to the fault, focus of earthquake energy, and type of geologic material. The composition of underlying soils, even those relatively distant from faults, can intensify ground shaking. For this reason, earthquake intensities are also measured in terms of their observed effects at a given locality. The Modified Mercalli (“MM”) intensity scale (see Table IV.N.1) is commonly used to measure earthquake damage due to ground shaking. The MM values for intensity range from I (earthquake not felt) to XII (damage is nearly total); intensities ranging from IV to X could cause moderate to significant structural damage.⁹ The intensities of an earthquake will vary over the region of a fault and generally decrease with distance from the epicenter of the earthquake.

Regional Faults

The San Andreas, Hayward, and Calaveras Faults pose the greatest threat of significant damage in the Bay Area according to the USGS Working Group.¹⁰ These three active faults exhibit strike-

⁷ United States Geological Survey Working Group on California Earthquake Probabilities (WG07), Fact Sheet 2008-2037, *Forecasting California’s Earthquakes – What Can We Expect in the Next 30 Years?*, also available at <http://pubs.usgs.gov/fs/2008/3027/fs2008-3027.pdf>, 2008.

⁸ California Geological Survey, *How Earthquakes Are Measured*, CGS Note 32, 2002; and, *Background Information on the ShakeMaps*, also available online at <http://earthquake.usgs.gov/eqcenter/shakemap/background.php>, May 11, 2009.

⁹ The damage level represents the estimated overall level of damage that would occur for various MM intensity levels. The damage, however, will not be uniform. Not all buildings perform identically in an earthquake. The age, material, type, method of construction, size, and shape of a building all affect its performance.

¹⁰ United States Geological Survey, *USGS Fact Sheet 039-03*, Working Group 02, 2003.

Table IV.N.1: Modified Mercalli Intensity Scale

Intensity Value	Intensity Description	Average Peak Acceleration (% g¹)
I	Not felt except by a very few persons under especially favorable circumstances.	< 0.17 g
II	Felt only by a few persons at rest, especially on upper floors of buildings. Delicately suspended objects may swing.	0.17-1.4 g
III	Felt noticeably indoors, especially on upper floors of buildings, but many people do not recognize it as an earthquake. Standing motor cars may rock slightly; vibration similar to a passing truck. Duration estimated.	0.17-1.4 g
IV	During the day felt indoors by many, outdoors by few. At night, some awakened. Dishes, windows, doors disturbed; walls make cracking sound. Sensation like heavy truck striking building. Standing motor cars rocked noticeably.	1.4-3.9g
V	Felt by nearly everyone, many awakened. Some dishes and windows broken; a few instances of cracked plaster; unstable objects overturned. Disturbances of trees, poles may be noticed. Pendulum clocks may stop.	3.5 – 9.2 g
VI	Felt by all, many frightened and run outdoors. Some heavy furniture moved; and fallen plaster or damaged chimneys. Damage slight.	9.2 – 18 g
VII	Everybody runs outdoors. Damage negligible in buildings of good design and construction; slight to moderate in well-built ordinary structures; considerable in poorly built or badly designed structures; some chimneys broken. Noticed by persons driving motor cars.	18 – 34 g
VIII	Damage slight in specially designed structures; considerable in ordinary substantial buildings, with partial collapse; great in poorly built structures. Panel walls thrown out of frame structures. Fall of chimneys, factory stacks, columns, monuments, walls. Heavy furniture overturned. Sand and mud ejected in small amounts. Changes in well water. Persons driving motor cars disturbed.	34 – 65 g
IX	Damage considerable in specially designed structures; well-designed frame structures thrown out of plumb; great in substantial buildings, with partial collapse. Buildings shifted off foundations. Ground cracked conspicuously. Underground pipes broken.	65 – 124 g
X	Some well-built wooden structures destroyed; most masonry and frame structures destroyed with foundations; ground badly cracked. Rails bent. Landslides considerable from riverbanks and steep slopes. Shifted sand and mud. Water splashed (sloped) over banks.	> 124 g
XI	Few, if any, (masonry) structures remain standing. Bridges destroyed. Broad fissures in ground. Underground pipelines completely out of service. Earth slumps and land slips in soft ground. Rails bent greatly.	> 1.24 g
XII	Damage total. Practically all works of construction are damaged greatly or destroyed. Waves seen on ground surface. Lines of sight and level are distorted. Objects are thrown upward into the air.	> 1.24 g

Note:

¹ g (gravity) = 980 centimeters per second squared. 1.0 g of acceleration is a rate of increase in speed equivalent to a car traveling 328 feet from rest in 4.5 seconds.

Source: Association of Bay Area Governments, *Modified Mercalli Intensity Scale, 2003*, also available online at <http://www.abag.ca.gov/bayarea/eqmaps/doc/mmi.html>; California Geological Survey, 2009. Background on Shakemaps, also available online at <http://earthquake.usgs.gov/earthquakes/shakemap/background.php>, accessed October 6, 2009.

slip orientation and have experienced movement within the last 150 years.¹¹ Other principal faults capable of producing significant ground shaking in the Bay Area are listed in Table IV.N.2 and include the Concord–Green Valley, Marsh Creek–Greenville, San Gregorio, and Rodgers Creek Faults. These active faults are in addition to the various inactive faults located throughout the Bay Area. A considerable seismic event can occur along an inactive fault, and occasionally faults classified as inactive can exhibit secondary movement during a major event on another active fault.

San Andreas Fault

The San Andreas Fault Zone is a major structural feature that forms at the boundary of the North American and Pacific tectonic plates, extending from the Salton Sea in Southern California near the border with Mexico to north of Point Arena, where the fault trace extends out into the Pacific Ocean. The main trace of the San Andreas Fault through the Bay Area trends northwest through the Santa Cruz Mountains, and along the eastern side of the San Francisco Peninsula. As the principal strike-slip boundary between the Pacific plate to the west and the North American plate to the east, the San Andreas is often a highly visible topographic feature, such as between Pacifica and San Mateo, where Crystal Springs Reservoir and San Andreas Lake clearly mark the rupture zone. Near San Francisco, the San Andreas Fault trace is located immediately off-shore near Daly City and continues northwest through the Pacific Ocean approximately 6 miles due west of the Golden Gate Bridge.

In the San Francisco Bay Area (“Bay Area”), the San Andreas Fault Zone was the source of the two major seismic events in recent history that affected the region. The 1906 San Francisco earthquake was estimated at M 7.9 (though estimates have ranged in publication from M 7.7 to as high as M 8.25) and resulted in approximately 290 miles of surface fault rupture, the longest of any known continental strike slip fault. Horizontal displacement along the fault approached 17 feet near the epicenter. The more recent 1989 Loma Prieta earthquake, with a magnitude of M 7.1 (Mw 6.9), resulted in widespread damage throughout the Bay Area, including Treasure Island.

Hayward Fault

The Hayward Fault Zone is the southern extension of a fracture zone that includes the Rodgers Creek Fault (north of San Pablo Bay), the Healdsburg Fault (Sonoma County), and the Mayacama Fault (Mendocino County). The Hayward Fault trends to the northwest across the East Bay, extending from San Pablo Bay in Richmond, 60 miles south to San Jose. The Hayward Fault in San Jose converges with the Calaveras Fault, a similar fault type that extends north to Suisun Bay.

¹¹ A strike-slip fault is a fault on which movement is parallel to the fault’s strike, which is the lateral expression at the surface.

Table IV.N.2: Active Faults in the Project Area Vicinity

Fault	Distance and Direction from Project Area	Known Dates of Movement	Fault Classification¹	Historical Seismicity²	Maximum Moment Magnitude Earthquake (Mw)³
San Andreas	11 miles southwest	Historic (1906; 1989 ruptures)	Active	M 7.1, 1989 M 7.9, 1906 M 7.0, 1838 Many <M 6	7.9
Hayward	7 miles northeast	Historic (1868 rupture)	Active	M 6.8, 1868 Many <M 4.5	7.1
Rodgers Creek	23 miles north	Historic	Active	M 6.7, 1898 M 5.6, 5.7, 1969	7.0
San Gregorio (including Seal Cove segment)	22 miles southwest	Prehistoric (Sometime prior to 1775 but after 1270 A.D.)	Active	n/a	7.3
Calaveras	21 miles southeast	Historic (1861 1911, 1984)	Active	M 5.6–M 6.4, 1861 M 6.2 1911, 1984	6.8
Marsh Creek–Greenville	25 miles east	Historic (1980 rupture)	Active	M 5.6 1980	6.9
Concord–Green Valley	22 miles northeast	Historic (1955)	Active	Historic active creep	6.7

Notes:

¹ As defined by the Alquist Priolo Earthquake Zoning Act.

² Richter magnitude (“M”) and year for recent and/or large events. The Richter magnitude scale reflects the maximum amplitude of a particular type of seismic wave.

³ Moment Magnitude (“Mw”) is related to the physical size of a fault rupture and movement across a fault. Moment magnitude provides a physically meaningful measure of the size of a faulting event. (Source: California Geological Survey (CGS), *How Earthquakes Are Measured*, CGS Note 32, 2002b. California Geological Survey (CGS), *Background Information on the ShakeMaps*, also available online at <http://earthquake.usgs.gov/eqcenter/shakemap/background.php>, May 11, 2009; United States Geological Survey, *USGS Fact Sheet 039-03*, Working Group 02, 2003). The Maximum Moment Magnitude Earthquake as shown in this column is a calculated estimate derived from the joint CGS/USGS Probabilistic Seismic Hazard Assessment for the State of California, 1996. (Source: Peterson, M.D., Bryant, W.A., Cramer, C.H., Probabilistic Seismic Hazard Assessment for the State of California, California Division of Mines and Geology Open-File Report issued jointly with U.S. Geological Survey, CDMG 96-08 and USGS 96-706, 1996.)

Sources: Hart, 1997; Jennings, C. W., Fault Activity Map of California and Adjacent Areas, California Division of Mines and Geology Data Map No. 6, 1:750,000, 1994; United States Geological Survey, *USGS Fact Sheet 039-03*, Working Group 02, 2003

Historically, the Hayward Fault generated one sizable earthquake in the 1800s.¹² In 1868, an M 7 earthquake on the southern segment of the Hayward Fault ruptured the ground for a distance of about 30 miles. Recent analysis of geodetic data indicates surface deformation may have extended as far north as Berkeley. Lateral ground surface displacement during these events was at least 3 feet.

A characteristic feature of the Hayward fault is its well-expressed and relatively consistent fault creep. Although no large earthquakes on the Hayward fault have occurred since 1868, slow fault creep has continued to occur and has caused measurable offset. Fault creep on the East Bay segment of the Hayward fault is estimated at 9 millimeters per year (“mm/yr”).¹³ However, a large earthquake could occur on the Hayward Fault with an estimated Mw 7.1 (Table IV.N.2). The USGS Working Group on California Earthquake Probabilities includes the Hayward–Rodgers Creek Fault Systems in the list of those faults that have the highest probability of generating earthquakes of M 6.7 or greater in the Bay Area.¹⁴

Calaveras Fault

The Calaveras Fault is a major right-lateral strike-slip fault that has been active during the last 11,000 years. The Calaveras Fault is located in the eastern portion of the Bay Area and generally trends along the eastern side of the East Bay Hills, west of San Ramon Valley, and extends into the western Diablo Range, and eventually joins the San Andreas Fault Zone south of Hollister. The northern extent of the fault zone is not completely understood and could be linked with the Concord Fault.

The fault separates rocks of different ages, with older rocks west of the fault and younger sedimentary rocks to the east. The location of the main, active fault trace is defined by youthful geomorphic features (linear scarps and troughs, right-laterally deflected drainage, sag ponds) and local groundwater barriers. There is a distinct change in slip rate and fault behavior north and south of the vicinity of Calaveras Reservoir, located primarily in Santa Clara and Alameda Counties. North of Calaveras Reservoir, the fault is characterized by a relatively low slip rate of 5 to 6 mm/yr and sparse seismicity. South of Calaveras Reservoir, the fault zone is characterized by a higher rate of surface fault creep that has been evidenced in historic times. The Calaveras

¹² Prior to the early 1990s, it was thought that an M 7 earthquake occurred on the northern section of the Hayward Fault in 1836. However, a study of historical documents by the CGS concluded that the 1836 earthquake was not on the Hayward Fault. (Source: Bryant, W.A., and Cluett, S.E., compilers, *Fault number 55a, Hayward fault zone, Northern Hayward section, in Quaternary fault and fold database of the United States, ver 1.0: U.S Geological Survey Open-File Report 03-417*, also available online at http://gldims.cr.usgs.gov/webapps/cfusion/Sites/qfault/qf_web_disp.cfm?qfault_or=1319&ims_cf_cd=cf&disp_cd=C, 2000.)

¹³ Peterson, M.D., Bryant, W.A., Cramer, C.H., Probabilistic Seismic Hazard Assessment for the State of California, California Division of Mines and Geology Open-File Report issued jointly with U.S. Geological Survey, CDMG 96-08 and USGS 96-706, 1996.

¹⁴ USGS, 2003.

Fault has been the source of numerous moderate magnitude earthquakes and the probability of a large earthquake (greater than M 6.7) is much lower than on the San Andreas or Hayward Faults.¹⁵ However, this fault is considered capable of generating earthquakes with magnitudes ranging as high as Mw 6.6 to 6.8.

Rodgers Creek Fault

The Rodgers Creek Fault Zone (“RCFZ”) is the southern segment of a fracture zone that includes the Rodgers Creek Fault (north of San Pablo Bay) and the Healdsburg Fault (northern Sonoma County). The most recent significant earthquakes on the RCFZ occurred on October 1, 1969, when two earthquakes of Richter magnitude 5.6 and 5.7 occurred within an 83-minute period. Buildings in Santa Rosa sustained serious damage during these quakes. Prior to these events, the last major earthquake (estimated Richter magnitude 6.7) was generated in 1898 with an epicenter near Mare Island at the north margin of San Pablo Bay. The USGS estimates the probability of a large earthquake (Mw 6.7 or greater) on the Hayward-Rodgers Creek Fault during the period 2003 to 2032 to be 27 percent, the highest probability for all San Francisco Bay fault zones.¹⁶ CGS and the Association of Bay Area Governments (“ABAG”) estimate the RCFZ is capable of generating a maximum Mw 7.0 earthquake.

Concord-Green Valley Fault

The Concord-Green Valley Fault extends from Walnut Creek north to Wooden Valley (east of Napa Valley). Historical record indicates that no large earthquakes have occurred on the Concord or Green Valley Faults.¹⁷ However, a moderate earthquake of M 5.4 occurred on the Concord Fault segment in 1955. The Concord and Green Valley Faults exhibit active fault creep and are considered to have a small probability of causing a significant earthquake.

Marsh Creek-Greenville Fault

The Greenville Fault, also known as the Marsh Creek-Greenville Fault, extends along the base of the Altamont Hills, which form the eastern margin of the Livermore Valley. The fault is recognized as a major structural feature and has demonstrated activity in the last 11,000 years. An M 5.6 earthquake on the Greenville Fault in 1980 produced a small amount of surface rupture (approximately 3 centimeters) on the fault near Vasco Road.

¹⁵ USGS, 2003.

¹⁶ USGS, 2003.

¹⁷ USGS, 2003.

SEISMIC HAZARDS

Surface Fault Rupture

Seismically induced ground rupture is defined as the physical displacement of surface deposits in response to an earthquake's seismic waves. The magnitude, orientation, and nature of fault rupture can vary for different faults or even along different strands of the same fault. Ground rupture is considered more likely along active faults, which are referenced in Table IV.N.1, p. IV.N.6.

The site is not within an Alquist-Priolo Fault Rupture Hazard Zone as designated through the Alquist-Priolo Earthquake Fault Zoning Act, and no mapped active faults are known to pass through the immediate vicinity of the Project Area. Therefore, the risk of ground rupture at the site is very low.

Ground Shaking

Strong ground shaking from a major earthquake could affect the Project Area during the next 30 years. Earthquakes on the active faults (listed in Table IV.N.2, p. IV.N.8) are expected to produce a range of ground shaking intensities within the Project Area. Ground shaking may affect areas hundreds of miles distant from the earthquake's epicenter. Historic earthquakes have caused strong ground shaking and damage in the Bay Area, the most recent being the M 6.9 Loma Prieta earthquake in October 1989. The epicenter was approximately 50 miles southeast of the Project Area, but this earthquake nevertheless caused strong ground shaking for about 20 seconds and resulted in varying degrees of structural damage throughout the Bay Area including incidents at Treasure Island.

The 1906 San Francisco earthquake, with an estimated Mw 7.9, produced violent (IX) shaking intensities in the Project Area.¹⁸ The 1989 Loma Prieta earthquake, with an Mw 6.9, produced very strong (VIII) shaking intensities in the Project Area.¹⁹

The common way to describe ground motion during an earthquake is with the motion parameters of acceleration and velocity in addition to the duration of the shaking. A common measure of ground motion is the peak ground acceleration ("PGA"). The PGA for a given component of motion is the largest value of horizontal acceleration obtained from a seismograph. PGA is expressed as the percentage of the acceleration due to gravity ("g"), which is approximately

¹⁸ Association of Bay Area Governments (ABAG), *Earthquake Hazards Maps for San Francisco, Modeled Shaking Intensity for 1906 San Andreas Fault Earthquake*, also available online at <http://www.abag.ca.gov/bayarea/eqmaps/eq06.html>, 2003.

¹⁹ ABAG, *Earthquake Hazards Maps for San Francisco, Modeled Shaking Intensity for 1989 San Andreas Fault Earthquake*, also available online at <http://www.abag.ca.gov/bayarea/eqmaps/eq89.html>, 2003.

980 centimeters per second squared. For comparison purposes, the maximum peak acceleration value recorded during the Loma Prieta earthquake was in the vicinity of the epicenter, near Santa Cruz, at 0.64 g. The highest value measured in the East Bay was 0.29 g, recorded at the Oakland Wharf near the Naval Supply Center where the soils are imported fill overlying Bay Mud. The lowest values recorded in the region were 0.06 g in the bedrock on Yerba Buena Island. The Fire Station at Treasure Island recorded a value of 0.16. However, an earthquake on the nearby Hayward fault or further north on the San Andreas would likely produce far more severe ground shaking at the site than was observed during the Loma Prieta earthquake. Probabilistic seismic hazard maps indicate that peak ground acceleration in the project region could reach or exceed 0.48 g.²⁰ The presence of non-engineered imported fill and Bay Mud in the Project Area could intensify ground-shaking effects, especially for any areas that have not received geotechnical stabilization. The potential hazards related to ground shaking are discussed further in the Impacts section, starting on p. IV.N.19.

Liquefaction

Liquefaction is a transformation of soil from a solid to a liquefied state during which saturated soil temporarily loses strength resulting from the buildup of excess pore water pressure, especially during earthquake-induced cyclic loading.²¹ Soil susceptible to liquefaction includes loose- to medium-dense sand and gravel, low-plasticity silt, and some low-plasticity clay deposits. Four kinds of ground failure commonly result from liquefaction: lateral spread, flow failure, ground oscillation, and loss of bearing strength. *Lateral spreading* is the horizontal displacement of surficial blocks of sediments resulting from liquefaction in a subsurface layer that occurs on gentle slopes and commonly displaces the surface by several meters to tens of meters. *Flow failures* generally occur on slopes greater than 3 degrees and are primarily liquefied soil or blocks of intact material riding on a liquefied subsurface zone. *Ground oscillation* occurs on gentle slopes when liquefaction occurs at depth and no lateral displacement takes place. Soil units that are not liquefied may pull apart from each other and oscillate on the liquefied zone.

²⁰ California Geological Survey, 2009. Probabilistic Seismic Hazards Ground Motion Page, also available online at <http://redirect.conservation.ca.gov/cgs/rghm/pshamap/pshamap.asp?Longitude=-122.37&Latitude=37.804>, accessed, October 6, 2009. A probabilistic seismic hazard map shows the predicted level of hazard from earthquakes that seismologists and geologists believe could occur. The map's analysis takes into consideration uncertainties in the size and location of earthquakes and the resulting ground motions that can affect a particular site. The maps are typically expressed in terms of probability of exceeding a certain ground motion. These maps depict a 10 percent probability of being exceeded in 50 years. There is a 90 percent chance that these ground motions will NOT be exceeded. This probability level allows engineers to design buildings for larger ground motions than seismologists think will occur during a 50-year interval, making buildings safer than if they were only designed for the ground motions that are expected to occur in the 50 years. Seismic shaking maps are prepared using consensus information on historical earthquakes and faults. These levels of ground shaking are used primarily for formulating building codes and for designing buildings.

²¹ In saturated soils, water exists in the void spaces between soil particle grains. An increase in soil water pressure indicates an increase in the pressures exerted against the soil particles, thereby reducing the frictional forces between the grains.

The *loss of bearing pressure* can occur beneath a structure when the underlying soil loses strength and liquefies. When this occurs, the structure can settle, tip, or even become buoyant and “float” upwards. Liquefaction and associated failures could damage foundations, roads, underground cables and pipelines, and disrupt utility service.

Liquefaction potential is generally very high in fill that has not been compacted to current standards. There are improved areas on Treasure Island where vibroflotation and compaction piles were used to densify the fill. The damage caused by the 1989 Loma Prieta earthquake was generally in areas where the fill was not treated for development. Lateral spreading was observed in an unimproved area on the north side of Treasure Island during the Loma Prieta Earthquake.

Based on the underlying materials and shallow depth of groundwater, the entire area of Treasure Island is considered to have a high risk of liquefaction. The CGS has identified areas of liquefaction potential as part of the Seismic Hazards Zonation Program (discussed below). All of Treasure Island and a shoreline portion of the eastern side of Yerba Buena Island are considered at risk for liquefaction.²²

Earthquake-Induced Settlement

Settlement of the ground surface can be accelerated and accentuated by earthquakes. During an earthquake, settlement can occur as a result of the relatively rapid compaction and settling of subsurface materials (particularly loose, uncompacted, and variable sandy sediments above the water table) due to the rearrangement of soil particles during prolonged ground shaking. Settlement can occur both uniformly and differentially (i.e., where adjoining areas settle at different amounts). Areas underlain by imported fill would be susceptible to this type of settlement. Given the geologic setting, portions of the Project Area, especially Treasure Island, could be subjected to earthquake-induced settlement unless geotechnical stabilization measures are implemented.

GEOLOGIC HAZARDS

Considering the geologic context of the Project Area and nature of the Proposed Project, other typical geologic hazards could include expansive soils, soil erosion, settlement, and landslides and slope failure. These hazards are discussed briefly below and provide the initial context for further evaluation in the impact analysis. Tsunami and seiche hazards are discussed in Section IV.O, Hydrology and Water Quality.

²² California Geological Survey, *Seismic Hazard Zones, Oakland West Quadrangle*, also available at http://gmw.consrv.ca.gov/shmp/download/pdf/ozn_oakw.pdf, February 14, 2003.

Expansive Soils

Expansive soils are characterized by their potential “shrink-swell” behavior. Shrink-swell is the cyclic change in volume (expansion and contraction) that occurs in certain fine-grained clay sediments from the process of wetting and drying. Clay minerals such as smectite, bentonite, montmorillonite, beidellite, vermiculite and others are known to expand with changes in moisture content. The higher the percentage of expansive minerals present in near surface soils, the higher the potential for significant expansion. The greatest effects occur when there are significant or repeated moisture content changes. Expansions of 10 percent or more in volume are not uncommon. This change in volume can exert enough force on a building or other structure to cause cracked foundations, floors, and basement walls. Damage to the upper floors of the building can also occur when movement in the foundation is significant. Structural damage typically occurs over a long period of time, usually the result of inadequate soil and foundation engineering or the placement of structures directly on expansive soils. The volume of expansive surface soils within the Project Area is minor.²³

Soil Erosion

Erosion is the wearing away of soil and rock by processes such as mechanical or chemical weathering, mass wasting, and the action of waves, wind and underground water. Excessive soil erosion can eventually lead to damage of building foundations and roadways. Within the Project Area, areas that are susceptible to erosion are those that would be exposed during the construction phase and along the shoreline where soil is subjected to wave action. Typically, soil erosion potential is reduced once the soil is graded and covered with concrete, structures, asphalt, or slope protection materials (such as geotextiles or vegetation). Soil erosion is a potential issue in the Project Area and is discussed in the Impacts section, starting on p. IV.N.19.

Settlement

Settlement can occur from immediate settlement, consolidation, and liquefaction (discussed above). Immediate settlement occurs when a load from a structure or placement of new fill material is applied, causing distortion in the underlying materials. This settlement occurs quickly and is typically complete after placement of the final load. Consolidation settlement occurs in saturated clay from the volume change caused by squeezing out water from the pore spaces. Consolidation occurs over a period of time and is followed by secondary compression, which is a continued change in the pore spaces under the continued application of the load.

²³ Engeo 2009, pp. 4-5; Engeo 2008, pp. 5-6.

Soils tend to settle at different rates and by varying amounts depending on the load weight or changes in properties over an area, which is referred to as differential settlement of the soils. Much of Treasure Island is underlain by poorly engineered imported fill that varies in depth and thickness; geotechnical borings indicate up to 50 feet of imported fill. Compressible Bay Mud underlies the fill and is up to 120 feet thick. Settlement is a potential issue in the Project Area and is discussed in the Impacts section, starting on p. IV.N.19.

Landslides and Slope Failure

Slope failures, commonly referred to as landslides, include many phenomena that involve the downslope displacement and movement of material, either triggered by static (i.e., gravity) or dynamic (i.e., earthquake) forces. A slope failure is a mass of rock, soil, and debris displaced downslope by sliding, flowing, or falling. Exposed rock slopes undergo rockfalls, rockslides, or rock avalanches, while soil slopes experience shallow soil slides, rapid debris flows, and deep-seated rotational slides. Landslides may occur on slopes of 15 percent or less; however, the probability is greater on steeper slopes that exhibit old landslide features such as scarps, slanted vegetation, and transverse ridges. Landslide-susceptible areas are characterized by steep slopes and downslope creep of surface materials. Debris flows consist of a loose mass of rocks and other granular material that, if saturated and present on a steep slope, can move downslope. The rate of rock and soil movement can vary from a slow creep over many years to a sudden mass movement. Landslides occur throughout California, but the density of incidents increases in zones of active faulting.

Slope stability can depend on a number of complex variables. The geology, structure, and amount of groundwater in the slope affect slope failure potential, as do external processes (i.e., climate, topography, slope geometry, and human activity). The factors that contribute to slope movements include those that decrease the resistance in the slope materials and those that increase the stresses on the slope. Slope failure under static forces occurs when those forces initiating failure overcome the forces resisting slope movement. For example, a slope may be considered stable until it becomes saturated with water (e.g., during heavy rains or due to a broken pipe or sewer line). Under saturated conditions, the water pressure in the individual pores within the soil increases, reducing the strength of the soil. Cutting into the slope and removing the lower portion, or slope toe, can reduce or eliminate the slope support, thereby increasing stress on the slope.

Earthquake motions can induce significant horizontal and vertical dynamic stresses in slopes that can trigger failure. Earthquake-induced landslides can occur in areas with steep slopes that are susceptible to strong ground motion during an earthquake. According to CGS mapping as part of

the Seismic Hazards Zonation Program, upland areas of Yerba Buena Island are considered at high risk of earthquake induced landslides.²⁴

Treasure Island is relatively flat, but much of its original perimeter rock dikes are founded by sand fills, which are subject to earthquake-induced instability that could result in deformation of the rock dikes. In addition, if the relatively thick Young Bay Mud deposits were subject to cyclic loadings from an earthquake or as a result of implementing densification of sand fills, a decrease in strength could occur, resulting in deep-seated slope failure.

REGULATORY FRAMEWORK

State

Seismic Hazards Mapping Act

The Seismic Hazards Mapping Act of 1990 was developed to protect the public from the effects of strong ground shaking, liquefaction, landslides, or other ground failure, and from other hazards caused by earthquakes. This act requires the State Geologist to delineate various seismic hazard zones and requires cities, counties, and other local permitting agencies to regulate certain development projects within these zones. Before a development permit may be granted for a site within a Seismic Hazard Zone, a geotechnical investigation of the site must be conducted and appropriate mitigation measures incorporated into a proposed project's design. The Project Area is located within a Seismic Hazard Zone for liquefaction and includes areas for landslides (on Yerba Buena Island only), as designated by the CGS. Therefore, evaluation and mitigation of potential liquefaction hazards must be conducted in accordance with the CGS, Special Publication 117, adopted March 13, 1997 by the State Mining and Geology Board pursuant to the Seismic Hazards Mapping Act. The San Francisco Department of Building Inspection ("DBI") is the local agency empowered by the City to enforce the regulatory requirements of the Act.

California Building Code and San Francisco Building Code

The California Building Code ("CBC") has been codified in the California Code of Regulations as Title 24, Part 2. Title 24 is administered by the California Building Standards Commission, which, by law, is responsible for coordinating all building standards. Under State law, all building standards must be centralized in Title 24 or they are not enforceable. The purpose of the CBC is to establish minimum standards to safeguard the public health, safety and general welfare through structural strength, means of egress facilities, and general stability by regulating and controlling the design, construction, quality of materials, use and occupancy, location, and maintenance of all building and structures within its jurisdiction. The CBC is based on the

²⁴ CGS, 2003.

International Building Code. The 2007 CBC is based on the 2006 International Building Code published by the International Code Conference. In addition, the CBC contains California amendments based on the American Society of Civil Engineers Minimum Design Standards 7-05 (“ASCE 7-05”). ASCE 7-05 provides requirements for general structural design and includes means for determining earthquake loads as well as other loads (flood, snow, wind, etc.) for inclusion into building codes. The provisions of the CBC apply to the construction, alteration, movement, replacement, and demolition of every building or structure or any appurtenances connected or attached to such buildings or structures throughout California. DBI adopted the 2007 CBC, effective January 2, 2008 with local amendments.

The CBC earthquake design requirements take into account the occupancy category of the structure, site class, soil classifications, and various seismic coefficients used to determine a Seismic Design Category (“SDC”) for a project. The SDC is a classification system that combines the occupancy categories with the level of expected ground motions at the site and ranges from SDC A (very small seismic vulnerability) to SDC E/F (very high seismic vulnerability and near a major fault). Design specifications are then determined according to the applicable SDC.

DBI was created as a separate City department under the Building Inspection Commission by voter referendum under Proposition G in 1994. The Charter amendment established the seven-member citizen body known as the Building Inspection Commission, which was designed to provide representation for the various communities that interact with the Building Department. The San Francisco Board of Supervisors has adopted the CBC with some additional amendments. The San Francisco Building Code includes amendments to the California Building Code and must be used in conjunction with State codes.

California Historical Building Code

The California Historical Building Code was created by legislation in 1975 giving authority to the State Historical Building Safety Board to write regulations, and have consultation, review, and appellate functions for code and regulation issues relating to qualified historic buildings, structures and properties.

A major feature of the California Historical Building Code is that it is a State law, a statute within the Health and Safety Code. The creation of regulations is separate from the California Building Code adoption process, pursuant to Health and Safety Code, Section 18944.7. The written regulations, the California Historical Building Code, are entitled “code” as well, but are effectively regulations adopted pursuant to Building Standards law.

The California Historical Building Code is not a “stand alone” code and relies on a “regular adopted code” such as the latest adopted California Building Code to be the standard from which

alternatives are derived. The 2007 California Historical Building Code is the most recent published update of this code.

Local

San Francisco Building Code

Chapter 16 of the San Francisco Building Code deals with structural design requirements governing seismically resistant construction (Section 1604), including (but not limited to) factors and coefficients used to establish seismic site class and seismic occupancy category for the soil/rock at the building location and the proposed building design (Sections 1613.5 and 1613.6). Chapter 18 includes (but is not limited to) the requirements for foundation and soil investigations (Section 1802); excavation, grading, and fill (Section 1803); allowable load-bearing values of soils (Section 1804); and the design of footings, foundations, and slope clearances (Section 1805), retaining walls (Section 1806), and pier, pile, driven, and cast-in-place foundation support systems (Section 1808, 1809, and 1810). Chapter 33 includes (but is not limited to) requirements for safeguards at work sites to ensure stable excavations and cut or fill slopes (Section 3304). Appendix J of the Building Code includes (but is not limited to) grading requirements for the design of excavations and fills (Sections J103 through J107) and for erosion control (Sections J109 and J110).

Compliance with the San Francisco Building Code is mandatory for development in San Francisco. Throughout the permitting, design, and construction phases of a building project, Planning Department staff, DBI engineers, and DBI building inspectors confirm that the requirements are being implemented by project architects, engineers, and contractors. During the design phase for a proposed new or remodeled structure, foundation support and structural specifications based on the preliminary foundation investigations would be prepared by the project engineer and architect and would be reviewed for compliance with the San Francisco Building Code by the Planning Department and DBI. During the construction phase, DBI inspectors would be responsible for enforcing the provisions of the Building Code as implemented by the contractor.

DBI implements the California Historical Building Code for alterations, repairs, or additions to qualified historic buildings, if requested to do so by the building owner.

San Francisco General Plan

One of the goals of the *San Francisco General Plan*, to the extent feasible, is to avoid the loss of life and property as a result of natural and technological disasters, to reduce the social, cultural and economic dislocations of disasters, and to assist and encourage the rapid recovery from

disasters. The following policies are from the Community Safety Element of the *San Francisco General Plan*:

- Policy 2.1: Assure that new construction meets current structural and life safety standards.
- Policy 2.3: Consider site soils conditions when reviewing projects in areas subject to liquefaction or slope instability.
- Policy 2.5: Assess the risks presented by other types of potentially hazardous structures and reduce the risks to the extent possible.
- Policy 2.9: Consider information about geologic hazards whenever City decisions that will influence land use, building density, building configurations or infrastructure are made.

The Community Safety Element includes maps of potential hazard areas, including liquefaction and potential liquefaction areas.

The Environmental Protection Element in the *San Francisco General Plan* addresses the impact of urbanization, including the use of oil and gas resources and hazardous waste on the natural environment. The Environmental Element contains three policies that relate to geology and soils:

- Policy 7.3: Require that filling of land adhere to the highest standards of soils engineering consistent with the proposed use.
- Policy 7.4: Assure correction of landslide and shore erosion conditions where it is in the public interest to do so.
- Policy 7.5: Prohibit construction, as a general rule, on land subject to slide or erosion.

IMPACTS

SIGNIFICANCE CRITERIA

The City and County of San Francisco has not formally adopted significance thresholds for impacts related to geology, soils, and seismicity. The Planning Department Initial Study Checklist form provides a framework of topics to be considered in evaluating potential impacts under CEQA. Implementation of a project could have a potentially significant impact related to geology, soils, and seismicity if it were to:

- Expose people or structures to potential substantial adverse effects, including the risk of loss, injury, or death involving:
 - Rupture of a known earthquake fault, as delineated on the most recent Alquist-Priolo Earthquake Fault Zoning Map issued by the State Geologist for the area or based on other substantial evidence of a known fault (Refer to Division of Mines and Geology Special Publication 42);
 - Strong seismic ground shaking;
 - Seismic-related ground failure, including liquefaction; or

- Landslides.
- Result in substantial soil erosion or loss of topsoil;
- Be located on a geologic unit or soil that is unstable, or that would become unstable as a result of the project, and potentially result in on- or offsite landslide, lateral spreading, subsidence, liquefaction or collapse;
- Be located on expansive soil, as defined in Table 18-1-B of the Uniform Building Code, creating substantial risks to life or property;
- Have soils incapable of adequately supporting the use of septic tanks or alternative wastewater disposal systems where sewers are not available for the disposal of wastewater; or
- Change substantially the topography or any unique geologic or physical features of the site.

APPROACH TO ANALYSIS

Based on the Proposed Project plan and its geographic location, the Proposed Project would not result in impacts related to the following criteria: fault rupture, expansive soils, wastewater disposal, collapsible soils, or changed topography or unique geologic features. No further impact discussion is provided for these topics for the following reasons:

- Fault Rupture. The faults most susceptible to earthquake rupture are active faults, which are faults that have experienced surface displacement within the last 11,000 years. There are no active faults that cross the Project Area, and the nearest proposed structure to an active fault is at least 7 miles away. Therefore, the potential for fault rupture to affect the Proposed Project elements is very low.
- Expansive Soils. The potential for damage to the Proposed Project from expansive soils is considered very low. There are almost no existing expansive soils on Treasure Island or Yerba Buena Island. Engineered fill materials are proposed for the Development Plan Area. The Proposed Project, as discussed further below, would require geotechnical improvements to site soils prior to development. Implementation of these methods would result in an overall lowering of the current ground surface. In order to bring the site grade to the ground surface elevation required for protection against flooding and future potential sea-level rise, new fill materials would be required. Placement of new fill materials would be required to meet stringent standards that preclude use of soils with significant expansion potential. Therefore, there would be no potential for expansive soils to impact the Proposed Project.
- Wastewater Disposal. The Project Area has an existing wastewater infrastructure that would be replaced with a new or upgraded wastewater treatment plant. The new or upgraded wastewater treatment plant would not require the use of any septic tanks or other alternative system requiring the percolation of wastewater into site soils. There would be no impact.
- Collapsible Soils. Soils that are susceptible to collapse are most often encountered in arid climates, where wind and intermittent streams deposit loose low-density materials. When placed under new loading or the addition of water that reaches deeper than under normal conditions, these soils can collapse causing structural damage. These conditions or soils

are not found in the Project Area, and therefore, there is no potential for collapsible soils and it is not discussed further in this section.

- Changed Topography or Unique Geologic Features. The Proposed Project would raise the overall grade of the relatively flat Treasure Island in addition to some minor grading in some areas of Yerba Buena Island in order to accommodate proposed improvements. However, the general topography would remain consistent with existing conditions. Treasure Island is an engineered infill island and there are otherwise no unique geologic features associated with either Treasure Island or Yerba Buena Island. There would be no impact related to changes in topography or unique geologic features and it is not discussed further in this section.

PROPOSED PROJECT APPROACH TO GEOTECHNICAL STABILIZATION

The geologic hazards present within the Project Area, particularly throughout Treasure Island, have been well studied and documented in previous geotechnical investigations that were summarized in the Geotechnical Conceptual Design Reports for both Yerba Buena and Treasure Islands.²⁵ As a result of these previous geotechnical studies, much is known about the underlying conditions including thicknesses of Bay Mud and imported fills. In addition, the conceptual design reports were peer reviewed by URS Corporation and a separate Independent Review Panel. The panel had previously reviewed earlier drafts of the conceptual design reports and participated in a geotechnical design workshop held in 2007. The findings of the panel determined that the geotechnical challenges for the proposed development can be addressed and optimal solutions developed.²⁶

The presence of hydraulically placed sand fills, existing shoal sands, and soft compressible Bay Mud at Treasure Island, in particular, present significant hazards for un-engineered structures during ground shaking and/or conditions that would induce liquefaction. In addition, the perimeter berms, originally constructed to retain sand fills during construction of the island, are also susceptible to seismic hazards at Treasure Island. However, as is commonplace for construction in such an environment, use of established geotechnical measures (discussed further below) can reduce these hazards to less-than-significant levels. A sound geotechnical approach typically includes improvements to the foundation soils, such as compaction or densification, combined with a building foundation design that takes into account underlying soil properties. Individual foundation designs vary depending on the size and height of the structure proposed.

The overall approach for the Proposed Project is to create a long-term stable platform on Treasure Island by densifying the underlying loose sand fill, and consolidating the compressible Young Bay Mud. A variety of techniques are available for densification of the sand fill, including deep

²⁵ Engeo, 2008 and 2009.

²⁶ Engeo, 2009, *Appendix 5H*.

dynamic compaction, and vibro-compaction.²⁷ Surcharging or preloading can be used to consolidate the Young Bay Mud.²⁸ Depending on the conditions and the desired results, surcharging can take anywhere from several months to several years to complete. For the Proposed Project, the phased approach of construction would allow for longer-term surcharging to occur in certain areas. Selection of final techniques for densification requires that site-specific data be collected and analyzed prior to implementation.

The geotechnical stabilization of existing materials would result in a lowering of the current ground surface. New fills would be required to compensate for this loss; adding fill would also provide an opportunity to raise the overall grade of the developed areas for protection against flooding and sea-level rise. The amount and depth of fills required to meet these goals would vary across Treasure Island, with less required for the south side and the most in the northwest corner.

In addition, the overall geotechnical approach of the proposed improvements considers the structural integrity of existing structures, specifically the Jobs Corps buildings, which are not a part of the Proposed Project but are adjacent to areas that would receive stabilization measures. If not managed appropriately, some measures can have adverse effects on existing structures. The Proposed Project would protect existing structures by using less impactful methods, such as vibro-compaction, in their vicinity. In addition, as is standard industry practice and typically required by DBI, monitoring equipment would be used to detect early indications of settlement on adjacent buildings.

The foundation system for each building site must be designed in accordance with the site-specific engineering properties of the materials beneath the proposed structure, combined with the intended loading (weight) of the proposed structure. These design criteria can only be developed with information obtained from a site-specific geotechnical investigation that is conducted according to the requirements of the relevant regulations. Site-specific investigations would more accurately determine the depth of the fill sands and Bay Mud at each building site. The identified depths would influence whether shallow foundations or deep foundation pilings are appropriate, the number and dimensions of each deep foundation piling (a primary consideration for each building site), and the seismic design coefficients used by structural engineers to determine the type and sizing of structural building materials. Once appropriately designed and subsequently constructed in accordance with local and State building code requirements, the structures would

²⁷ Densification refers to the compaction that results in a rearrangement of granular particles of the soil into a tighter arrangement to provide support for proposed structures. Dynamic compaction is a method of densifying soils by applying energy at the existing ground surface. Often the soils are densified through systematically lifting and dropping a heavy steel weight from a crane in a pre-determined grid pattern. Vibro-compaction is an alternative method of densification where the action of a vibrating probe combined with jetting water act to reorganize the soil particles in the borehole to a denser state.

²⁸ Surcharging is the placement of stockpiled soils to create a load on underlying materials that will, over time, cause existing fills and soils to compress or densify.

have the structural fortitude to withstand anticipated groundshaking and liquefaction without significant damage.

PROJECT IMPACTS

Impact GE.1: Construction activities within the Development Plan Area could loosen and expose surface soils. If this were to occur over the long term, exposed soils could erode by wind or rain, increasing the sediment load to San Francisco Bay. (*Less than Significant*)

Construction activities required for the development of the Proposed Project such as excavation, backfilling, grading, and placement of fill material for surcharging purposes can expose areas of loose soil previously protected by vegetation or surface improvements such as asphalt or concrete. If not properly stabilized or protected, these soils and fills could be subjected to soil loss and erosion by wind and storm water runoff. Concentrated water erosion, if not managed or controlled, can eventually result in significant soil loss. However, the project sponsors would be required by law to obtain a National Pollutant Discharge Elimination System (“NPDES”) Permit for Discharges of Stormwater Associated with Construction Activities from the San Francisco Regional Water Quality Control Board for all proposed construction as part of the Proposed Project. Conditions of this permit would include preparation and implementation of a Storm Water Pollution Prevention Plan (“SWPPP”). As also discussed in Section IV.O, Hydrology and Water Quality, a SWPPP includes specific construction-related Best Management Practices (“BMPs”) to prevent soil erosion and loss of topsoil. BMPs implemented could include, but would not be limited to, physical barriers to prevent erosion and sedimentation, construction of sedimentation basins, limitations on work periods during storm events, use of swales, protection of stockpiled materials, and a variety of other measures that would substantially reduce or prevent erosion from occurring during construction. (See also the discussion under Impact HY-1 of Section IV.O, Hydrology and Water Quality, p. IV.O.35.) The Proposed Project would not otherwise change drainage patterns to the extent that it would cause significant erosion resulting in damage to existing or proposed improvements. Once construction is completed throughout the various phases of proposed construction, the interior areas would be largely developed, with the exception of open spaces, and the shoreline areas would be protected by shoreline improvements. As a result, few locations would be created that would be exposed to the forces that cause erosion. With implementation of the requirements of the NPDES permit and the associated SWPPP, the potential impact of erosion and loss of topsoil would be less than significant. No mitigation is required.

Impact GE-2: In the event of a major earthquake in the region, seismic ground shaking could potentially injure people and cause collapse or structural damage to proposed structures or the perimeter berm. (*Less than Significant*)

The Project Area will likely experience at least one major earthquake (M 6.7 or higher) within the next 30 years. The intensity of such an event in the Development Plan Area would depend on the causative fault and the distance to the epicenter, the depth of the rupture below ground surface, the moment magnitude, and the duration of shaking. A seismic event in the Bay Area could potentially produce considerable ground accelerations within the Development Plan Area. The 1989 Loma Prieta earthquake caused damage within the area with an epicenter located approximately 50 miles away. A larger earthquake with a closer epicenter could cause even greater groundshaking within the Development Plan Area. A characteristic earthquake on the Hayward fault with an estimated M 7.1 could produce violent (IX) shaking in the Project Area.²⁹

Geotechnical Conceptual Design Reports were prepared for both Treasure Island and Yerba Buena Island.³⁰ These reports considered existing geotechnical data and preliminary geotechnical analyses conducted by Engeo Incorporated in collaboration with other engineering firms. The reports were independently reviewed by another geotechnical engineering firm (URS Corporation) as well as an independent review panel.³¹ The review panel concluded the significant geotechnical challenges involved in redeveloping the Development Plan Area could be addressed and optimal solutions developed. The likely solution to minimizing potential damage from an earthquake is to create a long-term stable platform across Treasure Island through a treatment of the fill sands known as densification. A variety of techniques are available for densification, including deep dynamic compaction and vibro-compaction. Deep dynamic compaction generally consists of repeatedly dropping a large weight onto the soil to rearrange soil particles into a denser configuration. Vibro-compaction is accomplished by advancing a vibrating probe into the ground, causing the relatively loose sands to compact and become denser. These proven geotechnical approaches, included as part of the Proposed Project, have been successfully applied at many locations and would effectively minimize the potential for earthquake-related damage to less-than-significant levels. The final selected techniques would vary across the Development Plan Area and depend greatly on the proposed improvements. For example, areas proposed for open space would require less stabilization efforts than areas proposed for multi-storied structures.

²⁹ ABAG, *Earthquake Hazards Maps for San Francisco, Modeled Shaking Intensity for Hayward Fault Earthquake*, also available online at <http://www.abag.ca.gov/bayarea/eqmaps/pickcity.html>, 2003.

³⁰ Engeo, 2008 and 2009. The purpose of a Geotechnical Conceptual Design Report is to generally describe the existing surface and subsurface conditions by reviewing existing data and identifying the salient geotechnical hazards present. Considering the geotechnical hazards, the conceptual design report then outlines feasible geotechnical solutions to overcome existing geotechnical challenges for the proposed elements of the project.

³¹ Engeo, 2009, *Appendix 5H*. Review comments provided by URS were incorporated into the 2009 report.

The perimeter berm around Treasure Island has been the subject of various repairs and improvements over the years; however, much of the original berm is still founded on dredged sands. These dredged sands are not considered to be stable during an earthquake and may lead to deformation of the berm. These sands may also benefit from densification by either of the methods described above. Although unlikely, densification of the sand and addition of fill could result in higher seismic stresses in the underlying Bay Mud, creating a possibility for a deep-seated slope failure to occur along the perimeter berm in the northwest corner of Treasure Island where the Bay Mud is thickest. Again, there are established geotechnical techniques available that can be implemented to reduce this potential hazard such as placing a surcharge load, an additional temporary weight, causing a controlled compression of the Young Bay Mud, or a process whereby deep soils are mixed with cement to form vertical soil-cement columns. For the causeway, most of the existing Young Bay Mud was removed during initial construction. Therefore, compression or settlement in this area would not receive the same level of geotechnical stabilization efforts.

Building foundations would be stabilized through various methods depending on the size of the structure proposed. The structures for the Proposed Project include a range of building heights from 2 to 60 stories. The proposed geotechnical improvements would densify and strengthen the site soils, allowing the use of shallow foundation for most low and mid-rise buildings, depending on exact location and design. High-rise buildings would also benefit from these geotechnical improvements, and in addition would require pile foundations that are anchored in more competent or structurally solid materials; pile foundation depth would depend on exact location and design. Figure IV.N.2: Areas of Proposed Geotechnical Improvements, shows the general areas of proposed geotechnical improvements.

As an alternative to compliance with the standards of the San Francisco Building Code, qualified historic structures may be altered in compliance with the requirements of the California Historical Building Code, Title 24 part 8 as implemented by DBI. This code is intended to facilitate the restoration or change of occupancy so as to preserve the original or restored elements and features, encourage energy conservation and a cost effective approach to preservation, and to provide for reasonable safety from seismic forces or other hazards for occupants and users of such “buildings, structures and properties.”³² Typically, the primary goal of providing reasonable safety is to minimize the potential for total collapse of an historic structure, which would reduce the potential impact of ground shaking on historic structures to less-than-significant levels.

Occupants of residential, office, and commercial buildings are also susceptible to injury and damage from nonstructural disruption during an earthquake. Examples of dangerous nonstructural damages that have occurred in past earthquakes include broken glass, the

³² “Reasonable safety” is determined by licensed professionals on a case-by-case basis during the building permit process.

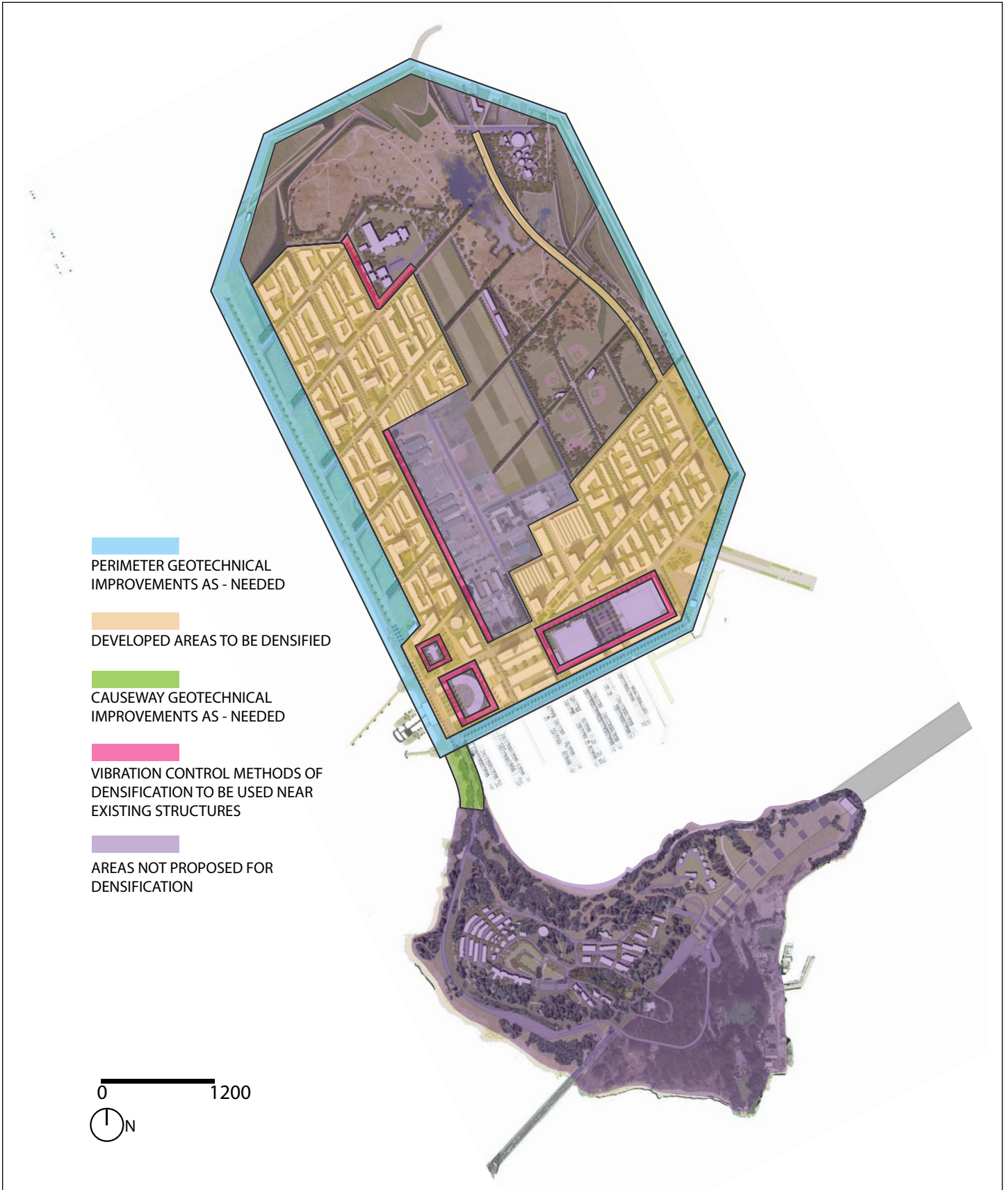

SOURCE: CMG, ENGEO

overturning of tall and heavy shelves, falling overhead light fixtures, ruptured piping containing hazardous substances, and falling pieces of brickwork or precast concrete panels. The most promising countermeasures for protection from nonstructural earthquake damage include securing shelves to walls and other heavy items as well as following regulatory requirements for storage of hazardous materials. Damage and injury from these causes cannot be entirely avoided; however, adherence to current commercial and regulatory practices including building code requirements, can reduce the potential for injury and damage to a less-than-significant level.

Geotechnical engineering methods for building design in accordance with CBC requirements have been used throughout the Bay Area shoreline areas where similar challenges of development on thick deposits of Bay Mud and imported fills have been encountered. In addition, impacts from a major seismic event would be further reduced by carrying out the site-specific analyses required by Chapter 16, Structural Design, and Chapter 18, Soils and Foundation, of the San Francisco Building Code as reviewed by DBI. This approach of preparing site-specific investigations is standard practice within the geotechnical engineering industry. Site-specific investigations are used to obtain site-specific data, such as the depths of artificial fill and Bay Mud, to be considered along with the proposed loading (size of building). Engineers would use this information to identify the design parameters for the spacing and dimensions of the foundation systems appropriate for each specific structure within the Development Plan Area. The findings of the Geotechnical Conceptual Design Report, including independent peer reviews, determined that an array of different foundation systems would be appropriate for all substantial structures in the Proposed Project. The site-specific investigations would be used to determine the specific design of the foundation systems for each structure. The results of the site-specific investigations would include specifications that would reduce the anticipated seismic risk hazards at the Development Plan Area to a less-than-significant level.

The Geotechnical Conceptual Design Report concludes that the entire area of Treasure Island proposed for development of buildings or roads, and soils beneath the perimeter berm, to the extent deemed necessary by a California licensed Geotechnical Engineer or Engineering Geologist, would be stabilized through geotechnical measures that conform to current industry standards and San Francisco Building Code requirements as part of the Proposed Project. Established geotechnical techniques are available that can be implemented to reduce the potential for deep-seated slope failure in the northwest corner of Treasure Island where Bay Mud is thickest, particularly under the perimeter berm. Placing a surcharge load, an additional temporary weight causing a slower controlled compression of the Young Bay Mud, or using a process whereby deep soils are mixed with cement to form vertical soil-cement columns, would be incorporated into the Proposed Project's design where Geotechnical Engineers determine these techniques would be appropriate to avoid this hazard.

The stabilization methods would be overseen by a California licensed Geotechnical Engineer or Engineering Geologist and completed in accordance with the most recent version of the San Francisco Building Code and any requirements imposed by DBI. The standards and techniques for stabilization are required to comply with the Building Code. Design parameters for walls, foundations, foundation slabs, and surrounding related improvements (utilities, roadways, sidewalks) would be based on a site-specific design-level geotechnical investigation report that must be submitted to DBI prior to issuance of a building permit for each building site as required in the San Francisco Building Code. Protection of existing structures outside of the Development Plan Area, especially the Jobs Corps campus buildings, would be monitored for settlement and given appropriate protection from adjacent geotechnical stabilization as overseen by a California licensed Geotechnical Engineer or Engineering Geologist and completed in accordance with any requirements issued by DBI.

Therefore, with adherence to building code requirements and implementation of established geotechnical stabilization measures that are part of the Proposed Project, the potential impacts from groundshaking would be reduced to less-than-significant levels.

Impact GE-3: In the event of a major earthquake in the region, seismic ground shaking could potentially expose people and property to liquefaction and earthquake-induced settlement. (*Less than Significant*)

CGS has designated the entire area of Treasure Island as a Seismic Hazard Zone (discussed above in “Regulatory Framework”) for liquefaction potential. Liquefaction at the site could result in loss of bearing pressure, lateral spreading, sand boils (liquefied soil exiting at the ground surface), and other potentially damaging effects. The Geotechnical Conceptual Design Report discusses at length the potential for liquefaction at the site. Both the fill sands and the original shoal sands have been identified as having a potential for liquefaction. Earthquake-induced settlement at Treasure Island resulting from liquefaction could be as much as approximately 24 inches if not engineered appropriately. The potential for liquefaction at Yerba Buena Island is generally low. On the eastern side of Yerba Buena Island there is a risk for liquefaction, but no structures are proposed in this area.

The Geotechnical Conceptual Design Report also noted a potential for lateral spreading (horizontal displacement of blocks of sediments) to cause damage along the perimeter of Treasure Island. Lateral spreading at the perimeter of Treasure Island could cause deformation of the existing rock dikes and rock slope protection improvements by the liquefied fill within the island. Lateral spreading could involve vertical and lateral ground deformation. However, densification of the site soils as part of the geotechnical stabilization methods discussed in Impact GE-2, above, would reduce the potential for liquefaction at the site for all proposed improvements. Densification of the fill sands and shoal sands allows the cohesionless soils to break down their existing soil structures and reform into a denser packing arrangement while dissipating excess

pore water. The installation of vertical wick drains, included as part of the Proposed Project, would accelerate the densification process prior to construction. These geotechnical engineering controls are proven techniques to reduce the hazards identified at the Development Plan Area.

In addition, all proposed development would be required to adhere to the requirements of the Seismic Hazards Zonation Program, which includes geotechnical engineering recommendations that are in compliance with the CGS Geology Guidelines for Evaluating and Mitigating Seismic Hazards, CGS Special Publication 117. Therefore, with implementation of the geotechnical stabilization elements of the Proposed Project, as discussed above in Impact GE-2, and with adherence to the regulatory requirements in the San Francisco Building Code and the CGS Seismic Hazards Zonation Program, the potential impacts from liquefaction and any resulting earthquake-induced settlement would be reduced to less-than-significant levels.

Impact GE.4: Development in the Development Plan Area could be subject to settlement over time from static forces. (*Less than Significant*)

The Treasure Island portion of the Development Plan Area consists of relatively thick layers of imported fill that was not compacted to current standards, and which are underlain by soft compressible Young Bay Mud. Young Bay Muds are susceptible to what is known as consolidation, which is an ongoing process in reaction to overlying loads. The existing fills and structures have already caused a certain amount of consolidation within the Young Bay Mud. However, the new loads associated with new construction and associated fill materials would likely cause a new round of consolidation settlements.

The amount and rate of consolidation settlement would depend on a number of different variables such as:

- The weight of any new fill or buildings over the weight of soil or buildings previously on the site;
- The amount of fill removed to compensate for new building loads (i.e., basement excavation);
- The thickness of the existing fill layers above the Bay Muds;
- The thickness of the Bay Mud deposit (including any dredged Bay Mud fill used originally to construct Treasure Island);
- The degree to which consolidation has already occurred in the upper portion of the Bay Mud;
- The presence of sand layers within the Bay Mud deposit; and
- The presence of existing foundation or other obstructions, particularly pile foundations.

Consolidation settlement from the new fill/structural loads would be expected to occur over a period of about 5 to 30 years, depending on the thickness of the Bay Mud. If not engineered appropriately, new development could be subject to significant damage to foundations, in

addition to damaged utilities where they connect to structures. The potential for consolidation settlements is typically addressed prior to development by placement of temporary loads or “surcharging” areas prior to development. Surcharging accelerates the amount of settlement that would normally occur with development so that the majority of anticipated settlement occurs prior to initial construction. Surcharging, as well as densification, is proposed, as described in Impact GE-2. In addition, prefabricated vertical drains, also known as wick drains, can be used to significantly decrease surcharge durations from years to months and would be specified as part of the surcharging process for specific development sites where appropriate. Wick drains allow pore waters that are being dissipated by the new loads to drain away more quickly, allowing settlement to occur faster. Therefore, with application of the densification methods, including surcharging, that are part of the Proposed Project and, further described above in Impact GE-2, the potential for settlement over time from static forces would be reduced to a less-than-significant level. In addition, developers and contractors for each new building proposed in the Development Plan Area would be required to construct appropriate foundations based on recommendations of a licensed Geotechnical Engineer, as reviewed and approved by DBI, that would further reduce the potential for settlement. Therefore, impacts due to settlement would be less than significant and no mitigation is required.

Impact GE.5: Development of the Proposed Project could result in potential damage or injury as a result of slope failures including the perimeter rock berms. (*Less than Significant with Mitigation*)

Treasure Island was created as a relatively flat manmade infill project, and the only areas with any significant slopes exist at the perimeter rock berms. Most of the original rock berms are founded on hydraulically placed dredged sediment fills. The original berms were constructed with relatively steep outer slopes of 1:1 (horizontal:vertical). Later in the 1980s, these slopes were flattened to a 2:1 slope, and in some places it is 4:1 with placement of additional rip-rap. Some isolated areas still have a 1:1 slope. However, a geotechnical evaluation of the static stability of these rock dikes determined an existing factor of safety ranging from 1.4 to 1.9. A value of 1.0 is an indication that a slope is susceptible to failure.³³ Typically, a factor of safety of 1.5 for static conditions is considered a safe and stable condition.³⁴ For the Development Plan Area, measures discussed above in Impact GE-2 that address the seismic hazards (liquefaction, lateral spreading, and groundshaking) would result in an increase in safety for the perimeter berms. The potential for deep-seated slope failure in the Bay Mud underlying the perimeter berm in the northwest corner of Treasure Island, and the established geotechnical techniques available to reduce this potential hazard, are discussed above in Impact GE-2. With implementation of these geotechnical stabilization elements of the Proposed Project, the slope stability hazards at Treasure Island would be less than significant.

³³ Engeo, 2009.

³⁴ Southern California Earthquake Center, *Recommended Procedures for Implementation of DMG Special Publication 117 Guidelines for Analyzing and Mitigating Landslide Hazards in California*, June 2002.

Yerba Buena Island, unlike Treasure Island, has upland areas with steep slopes with inclinations of 1.5:1 and 1:1. With the Proposed Project, any new grading is anticipated to result in slopes no steeper than 2:1 without additional geotechnical stabilization techniques applied. Incorporation of geotextile reinforcements and drainage improvements can provide adequate slope stabilization for slopes steeper than 2:1. The highest and most notable area of steep slopes occurs along Macalla Road. At least two areas of active landslides have been documented in this area including debris slides that occurred in 1949 and 1953. Previous geologic mapping suggests that the slope is underlain by colluvium and a series of other landslides at depth.³⁵ However, with implementation of Mitigation Measure M-GE-5, which requires setbacks from active landslides for the new buildings, the slope stability hazards can be overcome and reduced to less-than-significant levels.

Mitigation Measure M-GE-5: Slope Stability

New improvements proposed for Yerba Buena Island shall be located at a minimum of 100 feet from the top of the existing slope along Macalla Road unless a site-specific geotechnical

- evaluation of slope stability indicates a static factor of safety of 1.5 and a seismic factor of safety of 1.1 are present or established geotechnical stabilization measures are implemented to provide that level of safety. Any geotechnical recommendations regarding slope stability made in site-specific geotechnical investigations for the site shall be incorporated into the specifications for building on that site.

Impact GE.6: In the event of a major earthquake in the region, structural damage to viaduct structures or the ferry quay could hinder emergency rescue efforts. (Less than Significant)

The Project Area currently has limited egress routes, which in the event of a major earthquake could become significantly damaged. In particular, the viaduct bridge structures connecting the Treasure Island causeway to the Bay Bridge were determined to need retrofit to prevent collapse in an earthquake.³⁶ (Retrofit of the viaducts is included in the Yerba Buena Island Ramps Improvement Project under consideration by the San Francisco County Transportation Authority and Caltrans. Improvements to the causeway connecting the viaduct to Treasure Island are included in the Proposed Project and would avoid impact to emergency access to this area.) In addition, Macalla Road, which is not a viaduct, could become temporarily two-way to be more available for emergency access purposes. If the viaduct were to become unusable

- due to a major earthquake, transportation to and from Treasure Island would be available via ferry service, included as part of the Proposed Project. The ferry quay would be constructed on piles founded in competent materials at depth to support the boarding float. Alternate water access would continue to be available at Pier 1 on the east side of Treasure Island. The Proposed Project also includes emergency infrastructure elements such as on-site police and fire services, a

³⁵ Engeo, 2008.

³⁶ Biggs Cardosa, 2006.

supplemental water supply line on the east span of the Bay Bridge, back-up generators, and use of recycled water as a supplemental supply for firefighting purposes. Emergency and rescue services for the Proposed Project are also discussed in Section IV.L, Public Services. With the inclusion of the ferry service, on-Island police and fire services, and back-up utility infrastructure elements of the Proposed Project, the potential impact from limited access would be less than significant, and no mitigation is required.

CUMULATIVE IMPACTS

Cumulative Context

As discussed above, potentially significant project-level impacts relating to potentially hazardous geologic and seismic conditions would be reduced to less-than-significant levels through implementation of the geotechnical stabilization elements of the Proposed Project and Mitigation Measure M-GE-5. Although the entire Bay Area is within a seismically active region with a wide range of geologic and soil conditions, these conditions can vary widely within a short distance, making the cumulative context for potential impacts resulting from exposing people and structures to related risks one that is relatively localized or even site-specific. Projects underway or proposed in the immediate vicinity of the Proposed Project are the ongoing construction of the new east span of the Bay Bridge, the proposed new ramps connecting Yerba Buena Island to the Bay Bridge on the east side of the island, the proposed seismic retrofit of the viaduct that connects Treasure Island to the Bay Bridge on the west side of Yerba Buena Island, and the expanded marina in Clipper Cove.

Geology, Soils, and Seismic Cumulative Impacts

Impact GE.7: The development proposed as part of the Proposed Project, when combined with past, present and other reasonably foreseeable development in the vicinity, would not result in significant cumulative impacts with respect to geology, soils or seismicity. (*Cumulative Impact: Less than Significant*)

Development of the Proposed Project, with implementation of the identified mitigation measure above, would have less-than-significant impacts related to exposing persons or structures to geologic, soils, or seismic hazards. The Proposed Project, combined with other foreseeable development in the project vicinity including the new access ramps to the Bay Bridge on the east side of Yerba Buena Island, seismic retrofit of the viaduct structures on the west side of Yerba Buena Island, the new east span of the Bay Bridge, and the marina expansion in Clipper Cove, would result in increased population and development in an area subjected to seismic risks and hazards. However, the Proposed Project would represent the vast majority of that increase. While the number of people visiting, living and working in the area would increase, exposing additional people to seismic and geological hazards over a short term, the risk to people and property would be reduced through the upgrading or demolishing of older structures and

transportation facilities that are seismically unsafe and not constructed to current standards. Additionally, with the proposed seismic improvements, the existing population within the Project Area would benefit from a reduction in overall seismic hazards. All construction phases of this Proposed Project, and other foreseeable projects in the area, would be required to implement geotechnical stabilization features or mitigation measures similar to those discussed in this section and adhere to all State and local programs, requirements, and policies pertaining to building safety and construction permitting. All future projects within areas owned by TIDA would be required to adhere to the local building codes and grading ordinance. Caltrans is not bound by local building codes but would be required to comply with State regulations. Therefore, the Proposed Project, combined with other foreseeable development in the area, would not result in a cumulatively significant impact by exposing people or structures to risk related to geologic hazards, soils, and/or seismic conditions.

O. HYDROLOGY AND WATER QUALITY

This section describes the existing hydrological conditions in the Project Area and includes a discussion of surface water and groundwater resources, including water quality, flooding, stormwater runoff, water supply, and wastewater treatment. The Setting section is followed by a description of the regulatory framework that would apply to the implementation of the Proposed Project. A discussion of the potential impacts is provided, along with appropriate mitigation measures where applicable. For a review of existing conditions and potential impacts associated with water supply for the Project Area, please refer to Section IV.K, Utilities and Service Systems, “K.4, Water Supply and Distribution System.”

SETTING

SAN FRANCISCO BAY

San Francisco Bay surrounds the Project Area on all sides, and connects the Pacific Ocean to the west with San Pablo Bay, Suisun Bay, and the Sacramento-San Joaquin Delta to the north and east. The San Francisco Bay is an estuarine environment that receives saltwater inputs from the Pacific Ocean through the Golden Gate, and freshwater inputs from the Sacramento-San Joaquin Delta to the northeast, as well as various other tributary rivers and creeks located around the Bay.

Because the San Francisco Bay is directly connected to the Pacific Ocean (via the Golden Gate), the Bay exhibits a twice-daily tidal cycle. The mean tidal range is 4.1 feet, and the spring tidal range is 5.8 feet. The mean tide level is about 3.2 feet NAVD88.¹ The 100-year return tidal height (100-year tide) for the Project Area has been calculated to be 9.2 feet NAVD88.² The existing surface grade elevation on Treasure Island varies from approximately 6 to over 14 feet NAVD88; the existing grade on Yerba Buena Island is variable, and ranges up to a maximum height of about 350 feet NAVD88.

Waves at the Islands originate locally within San Francisco Bay as well as from the Pacific Ocean. Pacific Ocean waves are substantially dampened due to transformation processes within San Francisco Bay. Separately considering only those waves that originate in the Pacific Ocean and that could reach the project site, these waves would reach a maximum height of 1.6 feet, with

¹ NAVD88: North American Vertical Datum of 1988. This is a vertical reference point used for land surveying and other purposes.

² Moffatt and Nichol, Treasure Island Development Project Coastal Flooding Study, prepared for Treasure Island Community Development, April, 2009 (hereinafter “Coastal Flooding Study 2009”). A copy of this document is available for public review at the San Francisco Planning Department, 1650 Mission Street, Suite 400, in Case File No. 2007.0903E.

85 percent of such waves being less than 1 foot in height. These waves typically have a period³ of 10 to 13 seconds. Waves generated by wind within the Bay typically have a shorter period, and would reach peak heights of 4.2 feet under a 100-year wind event. More commonly, under a 5-year wind event, waves would reach a height of approximately 2.7 feet.⁴ Additional discussion of wave and tidal heights, as well as tsunami and the potential effects of climate change as relevant to flooding, are found under “Flooding, Waves, and Tsunami,” p. IV.O.5.

Currents in San Francisco Bay in the project vicinity result primarily from tidal flows through the Golden Gate and into the southern and northern portions of the Bay, and the Sacramento-San Joaquin Delta. During rising tidal conditions, currents flow generally east along the northern flank of Treasure Island, and southeast along the eastern and western sides of the Islands. During falling tidal conditions, the flows reverse, as water from the Bay flows out past the Islands, and through the Golden Gate. In general, tidal currents along the western side of the Islands, including in the vicinity of the proposed Ferry Terminal, are substantially stronger than the currents along the eastern side of the Islands. Other factors, including freshwater flows from the Delta and Bay watersheds, as well as wind effects, may also contribute to changes in currents. However, even under heavy runoff and wind events, bay currents overwhelmingly reflect the tidal cycle.⁵ Water quality in the Bay in the vicinity is salty and predominated by ocean influences. However, during periods of significant runoff, especially from the Sacramento-San Joaquin River system, substantial freshwater migrates through San Pablo Bay and into San Francisco Bay. This inundation of freshwater can temporarily reduce the salinity of waters in the project vicinity to substantially less than ocean water.⁶

Various contaminants are transported into the Bay by an assortment of sources: urban uses, industrial outfalls, municipal wastewater outfalls, municipal stormwater, upstream farming, upstream historic and current mining discharges, legacy pollutants,⁷ and various other pollutant sources. Water quality pollutants contained in the Bay at detectable levels include trace metals, pesticides, polychlorinated biphenyls (“PCBs”), polycyclic aromatic hydrocarbons (“PAHs”), algae blooms/low dissolved oxygen, and sediment contamination. Pollutant levels are variable seasonally and annually, dependent upon their specific source and degradation characteristics. Some contaminants, such as ammonia, copper, and legacy pesticides, have decreased over recent

³ The period of a wave is defined as the amount of time needed to complete a single oscillation of that wave (for example, from wave peak to wave peak).

⁴ Coastal Flooding Study 2009, p. 16.

⁵ SFPORTS, USGS Research Site for SFPORTS, 2009. <http://sfports.wr.usgs.gov/>, accessed October 22, 2009.

⁶ Bay Institute, The Bay Institute Ecological Scorecard, San Francisco Bay Water Quality Index. October 17, 2003 (hereinafter “Bay Institute, 2003”). http://www.bay.org/Scorecard/Water_Quality.pdf, accessed August 4, 2009.

⁷ Legacy pollutants are water quality constituents that are considered harmful to human health or the environment, that were historically emitted by industry or other human activities, and that are in general banned or significantly restricted from current usage. Examples include mercury, lead, PCBs, and DDT.

years due to cleanup efforts and natural attenuation.^{8,9} Other pollutants have been identified that are present at levels that impair beneficial use. These pollutants are subject to regulatory efforts to reduce their presence. As discussed in “San Francisco Regional Water Quality Control Board,” in “Regulatory Framework,” p. IV.O.14, San Francisco Bay, in the vicinity of the Project Area, is included on the Federal Clean Water Act 303(d) list for several water quality pollutants.

PROJECT AREA

Surface Water, Drainage, and Stormwater

There are no streams or other major surface water features located on the Islands. On both Islands, drainage is provided by an existing storm drain system, which captures and collects stormwater into a piped system and conveys flows, without treatment, into San Francisco Bay. During periods of heavy rain, runoff rates may exceed the capacity of the existing storm drain system. When this occurs on Treasure Island, stormwater is conveyed across the island and into the surrounding Bay via overland flow along surface streets and other surface features. When this occurs on Yerba Buena Island, stormwater is conveyed into the Bay via a combination of overland flow and naturally occurring, ephemeral drainages, which are located within the remaining undeveloped areas of the island.

The existing storm drainage system for both Islands is comprised of a series of 6-inch to 42-inch gravity-feed pipelines, which feed to approximately 29 lift stations as needed, and discharge along the perimeter of the Islands directly into San Francisco Bay. In total, there are approximately 31 stormwater outfalls on Treasure Island and approximately 32 outfalls on Yerba Buena Island. The existing stormwater management system that serves the Islands is antiquated and does not meet current design or treatment standards.

Groundwater

Yerba Buena Island is composed of a rocky outcrop of the Franciscan Assemblage that is common along coastal California. The Franciscan Assemblage is generally considered to be nongroundwater bearing, although some small areas on the island may contain a minor amount of groundwater, associated with localized alluvial¹⁰ sediments. Other geologic materials include

⁸ Regional Monitoring Program for Water Quality in the San Francisco Estuary. The Pulse of the Estuary, Monitoring and Managing Water Quality in the San Francisco Bay, September 2009. (Hereinafter “RMP 2009.”) http://www.sfei.org/rmp/pulse/2009/RMP_Pulse09_no583_final4web.pdf, accessed on April 16, 2010.

⁹ Bay Institute 2003.

¹⁰ Alluvium refers to loose sediments (i.e., not cemented into solid rock) – sand, rocks, gravel, silt, etc. – that were transported by waterborne processes.

dune sand and alluvium, which is unconsolidated and derived from wind-blown and marine terrace deposits, colluvium,¹¹ landslide debris, and limited artificial fill material.

Groundwater on Yerba Buena Island is not used for water supply, and no groundwater basin has been delimited by the California Department of Water Resources (“DWR”) for Yerba Buena Island or Treasure Island.¹² One small area of Yerba Buena Island near the Coast Guard Station and Sector Facility, on the eastern side of the island, contains sediments that hold groundwater. Groundwater levels in this area range from approximately 5 to 8 feet NAVD88.¹³ Additionally, groundwater data along Macalla Road indicate that groundwater depths there range from approximately 60 to 90 feet below ground surface (“bgs”).¹⁴

Although it has not been delimited by DWR, the sediments underlying Treasure Island do contain a lens of fresh water, which is replenished primarily by direct rainfall and landscape irrigation water used on Treasure Island. This groundwater is not, however, currently used as a source of potable water supply.

The upper approximately 5 feet of soils on Treasure Island is composed of fill dirt. Below 5 feet bgs, sediments are composed of discontinuous layers of sand, silt, clays, shell hash, and shell fragments. These layers were created from dredged sediments deposited during the initial construction of Treasure Island. The aquifer contained in these sediments is shallow and unconfined, and reaches a depth of 30 to 40 feet below ground surface. This shallow aquifer overlies a transition zone of silty sands and clays, which in turn overlies low permeability Bay deposits (Bay Mud). Groundwater levels on Treasure Island range from about 3.6 to 9.6 feet NAVD88, with the highest groundwater located near the center of the island associated with recharge in that area, and lower groundwater levels near its margins.¹⁵

Most groundwater recharge on the site occurs as a result of infiltration during the wet season, from November through April. Hydraulic conductivity within the shallow aquifer ranges from 5 to 16 feet per day, with an average of 10 feet per day. Groundwater levels on the edge of Treasure Island are also affected by the semidiurnal tidal cycle. Tidally induced fluctuation in

¹¹ Colluvium refers to loose sediments (i.e., not cemented into solid rock) that were transported down a slope by gravity.

¹² California Department of Water Resources. California’s Groundwater Bulletin 118, Update 2003 (hereinafter “DWR 2003”). <http://www.water.ca.gov/groundwater/bulletin118/update2003.cfm>, accessed October 1, 2009.

¹³ Tetra Tech, Compendium of Groundwater Level Data December 1994 through December 2002; Naval Station Treasure Island, San Francisco, CA. December 2003. (Hereinafter “Tetra Tech 2003.”)

¹⁴ Engeo, Incorporated, *Geotechnical Conceptual Design Report, Yerba Buena Island, San Francisco*, November 21, 2008. A copy of this document is available for public review at the San Francisco Planning Department, 1650 Mission Street, Suite 400, in Case File No. 2007.0903E.

¹⁵ Tetra Tech 2003.

groundwater levels was found to range from 1.8 to 0.1 feet for zones within 30 to 250 feet from the shore, respectively.¹⁶

Several portions of the Development Plan Area contain sediments that are contaminated with petroleum hydrocarbons, volatile organic carbons (“VOCs”), low-level radiological waste, dioxins, pesticides, PCBs, lead, other metals, and various other contaminants (see Section IV.P, Hazards and Hazardous Materials, for additional information). In some cases, the full extent of groundwater contamination has been identified for these sites; however, in other cases, additional investigation of groundwater contamination will be required by applicable regulatory agencies (DTSC, Regional Water Quality Control Board [RWQCB]). Prior to transfer of the relevant portion of the site from the Navy, these investigations will be completed consistent with State and Federal legal requirements of the applicable oversight agencies. Additional discussion of this issue is contained in Section IV.P, Hazards and Hazardous Materials.

Flooding, Waves, Tsunami, and Seiche

Several factors potentially affect flooding conditions in the Project Area. These include potential for flooding associated with stormwater that is incidental to the Islands; flooding of low-lying areas associated with normal, semidiurnal tidal action; waves originating inside and outside of San Francisco Bay; and tsunami.

The 100-year flood is the flood with a 1.0 percent probability of occurring in a given year. The Federal Emergency Management Agency (“FEMA,” a part of the U.S. Department of Homeland Security) issues 100-year floodplain maps. The 100-year floodplain maps are an integral part of the insurance and regulatory structure. FEMA manages the National Flood Insurance Program (“NFIP”). Under the NFIP, the Federal government provides financial backing for affordable flood insurance in exchange for the local government adopting and enforcing floodplain management regulations.¹⁷ In addition to insurance purposes, the FEMA 100-year floodplain maps are widely used to assess flood risk.

The City and County of San Francisco does not yet participate in the NFIP, but over the last several years has been undertaking a course of action to do so.¹⁸ The Mayor and Board of Supervisors approved a Floodplain Management Ordinance in 2008 that regulates new

¹⁶ Shaw Environmental. Pilot Study Monitoring Results. Document Control No. 9046, June 9, 2005.

¹⁷ City and County of San Francisco, Office of the City Administrator, “San Francisco Floodplain Management Program Fact Sheet” (one page), revised March 3, 2010. (Hereinafter “3/03/2010 Floodplain Fact Sheet.”) <http://www.sfgsa.org/Modules/ShowDocument.aspx?documentid=6824>, under “Land Use Committee, 03/08/10 Fact Sheet,” accessed June 13, 2010.

¹⁸ For more detail, see City and County of San Francisco, Office of the City Administrator, “San Francisco Floodplain Management Program Fact Sheet” (four pages), revised January 29, 2010. (Hereinafter “1/29/2010 Floodplain Management Program Fact Sheet.”) <http://www.sfgsa.org/Modules/ShowDocument.aspx?documentid=6769>, accessed June 13, 2010.

construction and substantial improvements to structures in flood-prone areas¹⁹ and prohibits uses that would increase flood risks. In general, the Floodplain Management Ordinance requires the first floor of structures in flood zones to be constructed above the floodplain or to be flood-proofed. The ordinance provides for variances for exceptional circumstances, including historic preservation and extraordinary hardship.

The City submitted an application to FEMA to join the NFIP in the fall of 2008.²⁰ As part of the review, FEMA requested changes to the City's Floodplain Management Ordinance.²¹ The Board of Supervisors is currently considering a revised Floodplain Management Ordinance in response to FEMA's request.²² As stated above, one of the purposes of a floodplain ordinance is to require new structures, substantial improvements, and substantial damage repairs in designated flood plain areas to be protected against flood damage.²³

FEMA prepared preliminary Flood Insurance Rate Maps ("FIRMs") for the City, including the Project Area, in September 2007.²⁴ Because the City has not completed the process for joining the NFIP, the City prepared interim floodplain maps in 2008. Assuming the City joins the NFIP, FEMA will issue final FIRMs. (FEMA is in the process of updating its maps for the City.)

Thus, at this time, the available floodplain maps for the Project Site are FEMA's 2007 preliminary FIRM²⁵ and the City's 2008 interim floodplain map.²⁶ FEMA tentatively identified special flood hazard areas on Treasure Island, consisting of "A zones" (subject to inundation by tidal surge) and "V zones" (subject to additional hazards that accompany wave action).

¹⁹ 1/29/2010 Floodplain Management Program Fact Sheet, p. 1.

²⁰ *Ibid.*

²¹ *Ibid.*

²² A Feb. 3, 2010 draft of the Board's revised Floodplain Management Ordinance is available at <http://www.sfgsa.org/Modules/ShowDocument.aspx?documentid=6767>, accessed June 13, 2010.

²³ *Ibid.*, Section 2A.280(c).

²⁴ FEMA's preliminary Flood Insurance Rate Maps issued September 2007 are available at <http://www.sfgsa.org/index.aspx?page=828>, accessed June 13, 2010.

²⁵ Treasure Island and Yerba Buena Island are shown in a combination of three FEMA map "panels", i.e., Federal Emergency Management Agency, Preliminary Flood Insurance Rate Map, City and County of San Francisco, California, Panels available on the San Francisco Floodplain Management Program's web site: Panel 130A, showing most of Treasure Island.

<http://www.sfgsa.org/Modules/ShowImage.aspx?imageid=2674>; Panel 110A, showing the northwest corner of Treasure Island. <http://www.sfgsa.org/Modules/ShowImage.aspx?imageid=2666>; and Panel 140A, showing the southern half of Yerba Buena Island. <http://www.sfgsa.org/Modules/ShowImage.aspx?imageid=2676>; all accessed June 13, 2010.

²⁶ San Francisco's Interim Floodplain Maps of July 2008 are available at <http://www.sfgsa.org/index.aspx?page=828>, accessed June 13, 2010. The "Citywide" map, showing Treasure Island, can be viewed at <http://www.sfgsa.org/Modules/ShowDocument.aspx?documentid=1761>, accessed June 13, 2010.

Figure IV.O.1: Proposed FEMA Flood Zone, shows the proposed extent of the 100-year special flood hazard area, which is likely to be adopted by FEMA. This is considered the best available assessment regarding potential 100-year flooding in the Project Site.

As shown, Yerba Buena Island is located outside of the proposed 100-year special flood hazard zone. However, a substantial portion of Treasure Island, in particular along the northwest portion of the island, as well as a smaller area along the southeastern edge of the island, is subject to 100-year flooding.

Treasure Island was constructed by building a containment dike and backfilling with sand. The present shoreline is protected by a berm that surrounds the entire island. The interior areas of Treasure Island are sufficiently elevated to provide protection from flooding associated with tidal action from the Bay. However, during storm events, the combined action of tides and waves results in inundation along shoreline areas, as well as flooding in the northwest and southwest portions of the island, because the perimeter berm has settled over time. Most portions of Yerba Buena Island are characterized as having relatively high topographic relief, and are not subject to inundation by Bay waters. Tidal flooding on Yerba Buena Island is limited to that island's beaches and other nondeveloped, low-lying areas that are located immediately adjacent to the Bay shore.

The shoreline of the Project Area is exposed to wind waves, swells, ship-wake waves, and tsunamis. The magnitude of ocean-derived swells and tsunamis are substantially dampened as they pass through the Golden Gate. As a result, the effects of swells and tsunamis on the Islands are anticipated to be lower than areas outside of the Bay, along the coast. In order to characterize the potential effects of tide, tsunami, and wind-generated waves on the Project Area, a coastal flooding study was completed.²⁷ The 100-year return period water level, including tide and tsunami, would result in a run-up of 9.2 feet NAVD88. Maximum wind-generated wave run-up elevations, for a 100-year event, would range from 10 to 16.3 feet NAVD88, with higher run-up values located along the northern portion of Treasure Island, and the lowest values along the eastern flank of the island.²⁸

A seiche is defined as a surface water free or standing wave oscillation that is contained within a partially or completely enclosed basin. Seiche is initiated by some event occurring within the enclosed basin – commonly meteorologic (e.g., wind or pressure changes), geologic (e.g., earthquake), or other mass movement such as a surface or subsurface landslide, which results in a sloshing of water within the basin as it reflects off the perimeter of the basin. San Francisco Bay

²⁷ Coastal Flooding Study 2009.

²⁸ Coastal Flooding Study 2009.

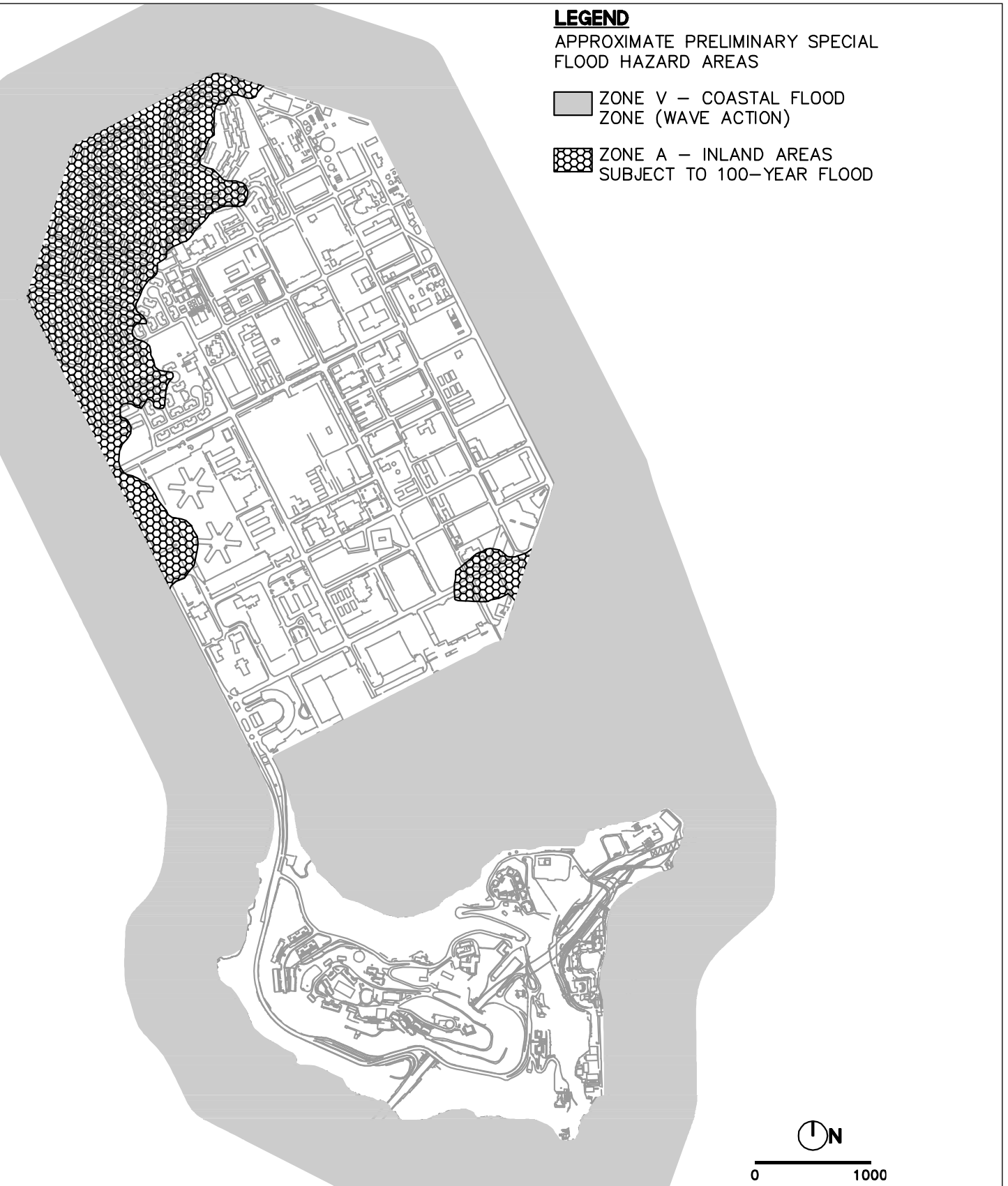

SOURCE: BKF

is partially enclosed, with outlets to San Pablo Bay, as well as the Pacific Ocean via the Golden Gate, and is relatively shallow, with a mean depth of approximately 27.6 feet (calculated from USGS, 2007).²⁹ Geologic-induced seiche events have not been documented in San Francisco Bay, and meteorologic effects are quickly dissipated due to the connection with the Pacific Ocean.

Wastewater Collection and Treatment

The existing wastewater collection and treatment system for the Islands is separate from the Islands' stormwater system. The wastewater collection system is composed of a series of gravity feed lines, sewage lift stations, and force mains that traverse the Islands. Portions of the existing wastewater collection system are in disrepair. The wastewater collection system from the Islands connects to an existing wastewater treatment plant ("treatment plant"), located along the northeast corner of Treasure Island. Wastewater from Yerba Buena Island is piped to the treatment plant via a pump station located under the Bay Bridge. For additional information regarding the existing wastewater system, refer to Section IV.K, Utilities and Service Systems.

The existing treatment plant was originally constructed in 1961. It was upgraded in 1969 to provide secondary treatment, and upgraded again in 1989. The current capacity of the plant is 2.0 mgd for dry weather flow and 8.0 mgd for wet weather flow. Actual flows from December 2005 through June 2009 ranged from 0.35 to 0.50 mgd, with higher flows occurring as a result of inflow and infiltration during wet weather.³⁰ Discharge from the treatment plant is permitted under National Pollutant Discharge Elimination System ("NPDES") Permit No. CA0110116, Order No. R2-2010-0001, issued by the San Francisco Bay RWQCB on January 10, 2010. Discharges from the treatment plant are monitored by the plant operator as a condition of the permit, and a summary of water quality parameters at the plant outfall from 2006-2009 is provided in Table IV.O.1. Current permit water quality requirements are provided in Table IV.O.2. Under the previous permit (Order No. R2-2004-0036), effluent discharge violations occurred as follows for the indicated constituents: October 2007: total recoverable cyanide; October 2008: total recoverable mercury; 2009 (annual sample): total recoverable mercury; 2009 (annual sample): methylmercury; and August 2007: pH.³¹

The current NPDES permit became effective on March 1, 2010, and will remain in effect through February 28, 2015. The RWQCB issued the NPDES permit to the Navy. The permit allows for discharge of secondary-treated wastewater from the existing facility into San Francisco Bay. It is

²⁹ U.S. Geological Survey. San Francisco Bay Bathymetry 2007. <http://sfbay.wr.usgs.gov/sediment/sfbay/geostat.html>, accessed April 19, 2010.

³⁰ RMP 2009.

³¹ U.S. Environmental Protection Agency, Enforcement and Compliance History Online (ECHO), Detailed Facility Report, 2010. (Hereinafter "EPA, 2010.") <http://www.epa-echo.gov/cgi-bin/get1cReport.cgi?tool=echo&IDNumber=CA0110116>, accessed June 7, 2010.

Table IV.O.1: Treatment Plant Effluent Water Quality, 2006–2009

Water Quality Constituent	Units	Average Value	Minimum Value	Maximum Value
pH	n/a	6.5	5.7	7.2
Total Suspended Solids	mg/L	10.5	8	14
Coliform, Total	MPN/100mL	14.5	ND	40
Copper, Total	µg/L	12.2	ND	18.2
Cyanide	µg/L	8.45	ND	10.7
Mercury, Total	µg/L	0.0123	ND	0.022
Zinc, Total	µg/L	30.6	ND	74.7

Notes: mg/L = milligrams per liter; MPN/100mL – Most Probable Number in 100 milliliters; ND = Not Detected; µg/L – micrograms per liter

Source: USEPA, 2010

Table IV.O.2: NPDES Permit Effluent Limitations, 2010–2015

Water Quality Constituent	Units	Effluent Limitations				
		Average Monthly	Average Weekly	Maximum Daily	Instantaneous Minimum	Instantaneous Maximum
Biochemical Oxygen Demand (5-day @ 20°C)	mg/L	30	45			
Total Suspended Solids	mg/L	30	45	n/a	n/a	n/a
Oil and Grease	mg/L	10	n/a	20	40	40
pH	n/a	n/a	n/a	n/a	6.0	9.0
Total Residual Chlorine	mg/L	n/a	n/a	n/a	n/a	0.0
Coliform, Total	MPN/100mL	The moving median value for MPN of total bacteria in five consecutive samples shall not exceed 240 MPN/mL				10,000

Water Quality Constituent	Units	Effluent Limitations	
		Average Monthly	Maximum Daily
Copper, Total	µg/L	33	46
Cyanide	µg/L	20	54
Dioxin	µg/L	1.4 x 10 ⁻⁸	4.4 x 10 ⁻⁸
Total Ammonia (as N)	mg/L	150	490

Notes: mg/L = milligrams per liter; MPN/100mL – Most Probable Number in 100 milliliters; µg/L = micrograms per liter

Source: California Regional Water Quality Control Board -- San Francisco Bay Region, Order No. R2-2010-0001, NPDES No. CA0110116, issued to U.S. Department of the Navy, re: "Treasure Island Wastewater Treatment Plant and its collection system," adopted January 13, 2010, p. 10 (Part IV, including Table 6).

written to meet a facility design capacity of 2.0 mgd with a permitted peak flow, providing secondary treatment under wet weather conditions of 4.4 mgd, with a service population of approximately 2,400. For additional discussion of the wastewater treatment plant, please see Section IV.K, Utilities and Service Systems.

The permit includes updated effluent limitations for the following water quality constituents: biochemical oxygen demand, total suspended solids, oil and grease, pH, total residual chlorine, total coliform bacteria, copper, cyanide, dioxin-TEQ, chlorodibromomethane, bis(2-ethylhexyl)phthalate, total ammonia, acute toxicity, chronic toxicity, and receiving water limitations for floating/suspended macroscopic materials or foams, nuisance aquatic bottom growth, temperature/turbidity/color alteration, visible/floating/suspended petroleum products, chemicals present in sufficient concentrations so as to have deleterious effects on wildlife as defined, and limits to water quality degradation within 1 foot of the water surface. The revised permit also includes a Copper Action Plan, a Cyanide Action Plan, and a Dioxin Compliance Schedule, to facilitate compliance with permit requirements. Mercury associated with the treatment plant's discharge is regulated under a separate NPDES Permit, No. CA0038849, Order No. 2008-0077.³² This separate permit regulates only discharges of mercury to San Francisco Bay, and no violations have been identified under this existing permit.

REGULATORY FRAMEWORK

Federal

Executive Order 11988

Under Executive Order 11988, FEMA is responsible for management of floodplain areas defined as the lowland and relatively flat areas adjoining inland and coastal waters subject to a 1 percent or greater chance of flooding in any given year (the 100-year floodplain). FEMA is a Federal agency whose overall mission is to support citizens and first responders to ensure that the United States builds, sustains, and improves capabilities to prepare for, protect against, respond to, recover from, and mitigate all hazards. With regard to flooding, FEMA provides information, guidance, and regulation associated with flood prevention, mitigation, and response. Under Executive Order 11988, FEMA requires that local governments covered by the Federal flood insurance program pass and enforce a floodplain management ordinance that specifies minimum requirements for any construction within the 100-year floodplain.

Through its Flood Insurance and Mitigation Administration, FEMA manages the National Flood Insurance Program, which includes flood insurance, floodplain management, and flood hazard mapping functions. FEMA maps 100-year floodplains within its jurisdiction and provides flood

³² Available at <http://www.epa-echo.gov/cgi-bin/get1cReport.cgi?tool=echo&IDNumber=CA0038849>, accessed June 7, 2010.

insurance rate information via flood insurance rate maps. Substantial FIRM changes may be completed via the Conditional Letter of Map Revision (“CLOMR”)/Letter of Map Revision (“LOMR”) process. A CLOMR is used when changes to the floodplain would result from new construction. The CLOMR functions as a means for FEMA to provide feedback regarding the extent to which it would consider revisions to its existing flood maps, as relevant. In order for the ‘conditional’ restriction to be lifted – that is, as relevant to the Proposed Project, in order to acquire a completed LOMR – FEMA typically requires completion of a detailed engineering analysis that investigates the extent of floodplains in the area in question. The LOMR process also requires a public notification period, a review period by FEMA, and an appeal period for property owners affected by the change. As discussed previously, FEMA has prepared only a preliminary FIRM, designating portions of Treasure Island as being within a 100-year floodplain. However, at the time of publication of this document, FEMA was in the process of updating its maps for the Project Area, which could include delineating a portion of the Project Area as susceptible to 100-year flooding. If this were to occur, then TIDA would apply for a CLOMR after the proposed improvements are designed and approved. After construction of these improvements, TIDA would apply for a final determination (LOMR) so that elevated portions of Treasure Island would not be included in the 100-year flood plain, as relevant. For additional discussion regarding the actions that the City has taken to respond to FEMA regulations, please refer to the discussion of the San Francisco Floodplain Management Ordinance in the summary of local ordinances and regulations, below.

The Clean Water Act (“CWA”)³³ is the major Federal legislation governing water quality. The objective of the CWA is “to restore and maintain the chemical, physical, and biological integrity of the Nation’s waters.” Important and applicable sections of the Act are:

- Sections 303 and 304, which provide for water quality standards, criteria, and guidelines. The State implements these sections through the State Water Resources Control Board (“SWRCB”) and the RWQCB, as discussed below.
- Section 401, which requires an applicant for any Federal permit that proposes an activity that may result in a discharge to “waters of the United States” to obtain certification from the State that the discharge will comply with other provisions of the Act. In California, certification is provided by the SWRCB.
- Section 402, which establishes the NPDES, a permitting system for the discharge of any pollutant (except for dredge or fill material) into waters of the United States. In California, this permit program is administered by the Regional Water Quality Control Boards, and is discussed in detail below. Anti-backsliding requirements provided for under CWA Sections 402(o)(2) and 303(d)(4) prohibit slackening of discharge requirements and regulations under revised NPDES permits. With isolated/limited exceptions, these regulations require effluent limitations in a reissued permit to be at least as stringent as those contained in the previous permit.

³³ Title 33, United States Code, Sections 1251–1376.

- Section 404, which establishes a permit program for the discharge of dredged or fill material into waters of the United States. This permit program is administered by the U.S. Army Corps of Engineers.

Federal Safe Drinking Water Act

The purpose of the Safe Drinking Water Act (1974) is to protect public health by regulating the nation's public drinking water supply. The law prescribes several actions that protect drinking water and its sources, including rivers, lakes, reservoirs, springs, and groundwater wells, although the Act does exclude drinking water wells that serve fewer than 25 persons. The law was amended in 1986 and 1996, and its implementation is overseen by the U.S. Environmental Protection Agency (EPA). Consequently, the EPA is authorized to set national health-based standards for drinking water to protect against natural and man-made contaminants in drinking water.³⁴

Federal Antidegradation Policy

The Federal antidegradation policy, established in 1968 in Section 303 of the Clean Water Act, is designed to protect existing uses and water quality and national water resources. The Federal policy directs states to adopt a statewide policy that includes the following primary provisions:

- Existing instream uses and the water quality necessary to protect those uses shall be maintained and protected.
- Where existing water quality is better than necessary to support fishing and swimming conditions, that quality shall be maintained and protected unless the state finds that allowing lower water quality is necessary for important local economic or social development.
- Where high-quality waters constitute an outstanding national resource, such as waters of national and state parks, wildlife refuges, and waters of exceptional recreational or ecological significance, that water quality shall be maintained and protected.

State

Porter-Cologne Water Quality Control Act

The Porter-Cologne Water Quality Control Act, as revised in December 2007, provides for protection of the quality of all waters of the State of California for use and enjoyment by the people of California. It further provides that all activities that may affect the quality of waters of the State shall be regulated to obtain the highest water quality that is reasonable, considering all demands being made and to be made on those waters. The Act also establishes provisions for a Statewide program for the control of water quality, recognizing that waters of the State are

³⁴ U.S. Environmental Protection Agency (EPA), 2006 Edition of the Drinking Water Standards and Health Advisories. EPA 822-R-06-013. August 2006.

increasingly influenced by interbasin water development projects and other Statewide considerations, and that factors such as precipitation, topography, population, recreation, agriculture, industry, and economic development vary regionally within the State. The Statewide program for water quality control is therefore administered most effectively on a local level with Statewide oversight. Within this framework, the Act authorizes the SWRCB and regional boards to oversee the coordination and control of water quality within California.

Total Maximum Daily Loads

Under CWA Section 303(d) and the Porter-Cologne Water Quality Control Act, the State of California is required to establish beneficial uses of state waters and to adopt water quality standards to protect those beneficial uses. Section 303(d) establishes the Total Maximum Daily Load (“TMDL”) process to assist in guiding the application of state water quality standards, requiring the states to identify waters whose water quality is “impaired” (affected by the presence of pollutants or contaminants) and to establish a TMDL or the maximum quantity of a particular contaminant that a water body can assimilate without experiencing adverse effects on the beneficial use identified.

State Water Resources Control Board

Created by the California State Legislature in 1967, the State Water Resources Control Board holds authority over water resources allocation and water quality protection within the State. The five-member SWRCB allocates water rights, adjudicates water right disputes, develops Statewide water protection plans, establishes water quality standards, and guides the nine Regional Water Quality Control Boards. The mission of the SWRCB is to, “preserve, enhance, and restore the quality of California’s water resources, and ensure their proper allocation and efficient use for the benefit of present and future generations.”

San Francisco Bay Regional Water Quality Control Board

The RWQCBs are responsible for oversight and implementation of water quality standards and programs, as delegated by the SWRCB. To this end, the San Francisco RWQCB implements the Water Quality Control Plan for the San Francisco Bay Basin (“Basin Plan”).³⁵ This document is the RWQCB’s master water quality control planning document. It designates beneficial uses and water quality objectives for “waters of the State,”³⁶ including surface waters and groundwater, and includes programs of implementation to achieve the water quality objectives. The Basin Plan has been adopted and approved by the SWRCB, EPA, and the Office of

³⁵ San Francisco Bay Regional Water Quality Control Board, 2006 CWA Section 303(d) List of Water Quality Limited Segments Requiring TMDLs. EPA Approval Date: June 28, 2007. (Hereinafter “RWQCB 2007.”)

³⁶ “Waters of the State” includes all surface water or groundwater, including saline waters, within the boundaries of the state of California.

Administrative Law. The Basin Plan identifies the following existing beneficial uses for San Francisco Bay in the vicinity of the Project Area: industrial service supply; industrial process supply; ocean, commercial, and sport fishing; shellfish harvesting; estuarine habitat; fish migration; preservation of rare and endangered species; fish spawning; wildlife habitat; water contact recreation; noncontact water recreation; navigation.

Additionally, Section 303(d) of the CWA requires that states develop a list of water bodies that do not meet water quality standards, establish priority rankings for waters on the list, and develop action plans, called Total Maximum Daily Loads (TMDLs), to improve water quality. The list of impaired water bodies is revised periodically, and TMDL development is overseen by RWQCB, within its area of jurisdiction. San Francisco Bay, in the vicinity of the Project Area, is included on the CWA Section 303(d) list for the following constituents: chlordane, DDT, dieldrin, dioxin compounds (including 2,3, 7,8-TCDD), exotic (e.g., non-native) species, furan compounds, mercury, PCBs, PCBs (dioxin-like), and selenium.³⁷ The RWQCB is also in the process of updating this list to include trash as a listed constituent.

California State Nondegradation Policy

In 1968, as required under the Federal antidegradation policy described above, the SWRCB adopted a nondegradation policy aimed at maintaining high quality for waters in California. The nondegradation policy states that the disposal of wastes into State waters shall be regulated to achieve the highest water quality consistent with maximum benefit to the people of the State and to promote the peace, health, safety, and welfare of the people of the State. The policy provides as follows:

- a. Where the existing quality of water is better than required under existing water quality control plans, such quality would be maintained until it has been demonstrated that any change would be consistent with maximum benefit to the people of the State and would not unreasonably affect present and anticipated beneficial uses of such water.
- b. Any activity which produces waste or increases the volume or concentration of waste and which discharges to existing high-quality waters would be required to meet waste discharge requirements which would ensure (1) pollution or nuisance would not occur and (2) the highest water quality consistent with the maximum benefit to the people of the State would be maintained.

NPDES General Permit for Discharges of Stormwater Associated with Construction Activities

Construction activities disturbing 1 acre or more of land are subject to the permitting requirements of the NPDES General Construction Activity Permit for Discharges of Storm Water Runoff Associated with Construction Activity (“General Construction Permit”). A new permit was adopted, effective July 1, 2010, replacing a previous permit that expired on June 30, 2010. The

³⁷ RWQCB 2007.

new permit requires a risk-based permitting approach, dependent upon the likely level of risk imparted by a project. The new permit also contains several additional compliance items, including (1) additional mandatory Best Management Practices (“BMPs”) to reduce erosion and sedimentation, which may include incorporation of vegetated swales, setbacks and buffers, rooftop and impervious surface disconnection, bioretention cells, rain gardens, rain cisterns, implementation of pollution/sediment/spill control plans, training, and other structural and nonstructural actions; (2) sampling and monitoring for nonvisible pollutants; (3) effluent monitoring and annual compliance reports; (4) development and adherence to a Rain Event Action Plan; (5) requirements for the post-construction period; (6) numeric action levels and effluent limits for pH and turbidity; (7) monitoring of soil characteristics on site; and (8) mandatory training under a specific curriculum. Under the revised permit, BMPs will be incorporated into the compliance action and monitoring requirements for each development site, as compared to the existing permit, where specific BMPs are implemented via a Storm Water Pollution Prevention Plan (“SWPPP”). Under the updated permit, a SWPPP would be reviewed by the RWQCB. However, additional monitoring, reporting, and training requirements for management of stormwater pollutants will also be implemented, unless the new permit is challenged and set aside prior to its implementation.

NPDES Small Municipal Separate Storm Sewer System General Permit

Municipal Separate Stormwater Sewer Systems (“MS4”) in San Francisco are permitted through the Small Municipal Separate Storm Sewer System General Permit (General Permit, CAS000004) adopted by the SWRCB in 2003. The City of San Francisco is considered a small municipal discharger, which is regulated under Phase II of the NPDES program because the population served by separate storm sewers is less than 100,000. NPDES permits are valid for a 5-year period. The City’s existing Small MS4 general permit was renewed in January 2010.

Recycled Water Use Under California Code of Regulations Title 22

Title 22 of the California Code of Regulations provides requirements for the provision of recycled water by municipal utilities, including requirements for minimization of hazardous contaminants within the recycled water, and various operational and monitoring criteria. These regulations also provide limitations for the usage of recycled water. Specifically, recycled water may be used for groundwater recharge; irrigation of food crops; irrigation of landscaping including parks, playgrounds, school yards, residential landscaping, freeway landscaping, golf courses, and other municipal irrigation uses; industrial uses such as cooling towers, toilet flushing, urinals, industrial process water, soil compaction, mixing of concrete, and the flushing of sanitary sewers.

In 2007, the State passed AB 1406, amending Section 13553 of the California Water Code, and authorizing the use of recycled water for toilet and urinal flushing in condominium projects created after January 1, 2008, subject to specified conditions: (1) potable water service to the condominium project must have a backflow protection device approved by the State to protect the

public, potable water supply; (2) plumbing modifications must be done in accordance with plumbing codes; (3) a condominium project's potable and nonpotable systems must be tested at least every 4 years for cross-connections; (4) recycled water lines must be color coded; (5) notices of the use of recycled water must be provided to buyers and owners; and other conditions.³⁸

State Water Resources Control Board Recycled Water Policy

The SWRCB's Recycled Water Policy was adopted on February 3, 2009. The purpose of the policy is to increase the use of recycled water from municipal wastewater sources in a manner that implements relevant water quality laws. The SWRCB adopted the policy in the wake of several California water supply and water quality issues, including changes in the Sacramento-San Joaquin Delta, climate change, continued population growth, and recent droughts. The policy adopts the following goals with reference to recycled water:

- Increase the use of recycled water over 2002 levels by at least 1 million acre-feet per year (“afy”) by 2020 and by at least 2 million afy by 2030.
- Increase the use of stormwater over use in 2007 by at least 500,000 afy by 2020 and by at least 1 million afy by 2030.
- Increase the amount of water conserved in urban and industrial uses over 2007 levels by at least 20 percent by 2020.
- Included in these goals is the substitution of as much recycled water for potable water as possible by 2030.

NPDES General Permit for Landscape Irrigation Uses of Municipal Recycled Water

In July 2009, the State Water Resources Control Board adopted General Waste Discharge Requirements for Landscape Irrigation Uses of Municipal Recycled Water (“General Permit”). For those eligible, the General Permit allows the use of recycled water for landscape irrigation. Uses included under the “landscape irrigation” designation include parks, greenbelts, and playgrounds, school yards, athletic fields, golf courses, cemeteries, residential landscaping, common areas, commercial landscaping except eating areas, industrial landscaping except eating areas, and freeway, highway, and street landscaping. An applicant may apply for coverage under the General Permit by filing a Notice of Intent, providing a complete Operation and Maintenance Plan, and submitting the appropriate fee to the State Water Resources Control Board.

Dredged Material Management Office

The Dredged Material Management Office (“DMMO”) regulates dredging and dredged material in the San Francisco Bay region. The DMMO consists of representatives from the EPA -

³⁸ Calif. Water Code Section 13553(d).

Region 9; U.S. Army Corps of Engineers-San Francisco; San Francisco Bay RWQCB; the San Francisco Bay Conservation and Development Commission (“BCDC”); and the State Lands Commission. The DMMO serves as the single point of entry for applicants to the dredging and disposal permitting process. The DMMO serves as a clearinghouse for all dredging projects in San Francisco Bay, facilitating the implementation of dredging requirements and regulations, following rules that divide dredging projects into two categories: (1) small dredging projects defined by a project depth of less than -12 feet mean lower low water (“MLLW”) and generating less than 50,000 cubic yards per year on average; and (2) other dredging projects defined by project depth greater than -12 feet MLLW or average annual volumes greater than 50,000 cubic yards.³⁹

Long Term Management Strategy for the Placement of Dredged Material in the San Francisco Bay Region, Management Plan 2001

The Long Term Management Strategy for the Placement of Dredged Material in the San Francisco Bay Region, Management Plan (“LTMS Management Plan”)⁴⁰ was promulgated by the U.S. Army Corps of Engineers, as well as the EPA, BCDC, and RWQCB, in order to regulate the fate of dredged material in San Francisco Bay. The LTMS Management Plan goals are to maintain in an economically and environmentally sound manner those channels necessary for navigation in the San Francisco Bay and Estuary and eliminate unnecessary dredging activities; conduct dredged material disposal in the most environmentally sound manner; maximize the use of dredged materials as a resource; and maintain the cooperative permitting framework for dredging and disposal applications.

Since its implementation, the LTMS Management Plan has significantly reduced the amount of dredge materials that are directly disposed of in the Bay, when compared to historical levels. Some in-Bay disposal is still allowed under the LTMS Management Plan, although most dredge materials are currently disposed of in the ocean, or are put to beneficial use in upland/reuse areas.

In order to meet compliance with the LTMS Management Plan, dredging operations must be approved via a permitting process, through the DMMO. The DMMO is a joint program of the BCDC, RWQCB, U.S. Army Corps of Engineers, EPA, and the State Lands Commission. The DMMO provides permitting support for dredging materials management. The permitting process includes initial testing to determine if the dredged material is suitable for reuse or disposal. Following testing and approval of a suitability determination, the project may proceed into the permitting process. The final permit may require that dredged material be disposed of or slated

³⁹ U.S. Army Corps of Engineers, U.S. Environmental Protection Agency, San Francisco Bay Conservation and Development Commission, San Francisco Bay Regional Water Quality Control Board (U.S. Army Corps of Engineers and others), 2001. Long-Term Management Strategy for the Placement of Dredged Material in the San Francisco Bay Region, Management Plan 2001. (Hereinafter “LTMS Management Plan, 2001.”) <http://www.spn.usace.army.mil/lrms2001>, accessed January 13, 2010.

⁴⁰ LTMS Management Plan 2001.

for reuse, for example, in support of wetland creation, levee reconstruction, in-Bay habitat creation, or following processing, for cover material at landfills or construction purposes. A variety of beneficial use sites for dredge materials are located around the Bay.

Dredge materials may also be scheduled for reuse on site, as applicable, as a result of the permitting process. During the permitting process, specific dredging work windows may be imposed, in order to protect biological resources; if dredging work windows cannot be met, consultation with the California Department of Fish and Game will be required. Finally, in order to authorize aquatic disposal of dredged materials, an analysis of potential alternatives must first be performed, showing that alternatives to aquatic disposal are either environmentally unacceptable or infeasible, in accordance with BCDC standards. Dredging and disposal fees, due to the BCDC and the RWQCB, may apply. The requirements outlined in the LTMS are implemented under permits that are issued by the U.S. Army Corps of Engineers, the RWQCB, and BCDC. Consultation with Federal resource agencies may also be required in the event that the proposed dredging would potentially affect special status species. For additional discussion of potential effects on special status species, please refer to Section IV.M, Biological Resources.

Sea Level Rise and Executive Order S-13-08

In November 2008, Governor Arnold Schwarzenegger issued Executive Order S-13-08. The order indicates that future potential sea level rise associated with climate change may have a substantial effect on coastal development, and provides for the formation of an independent panel that will complete a California Sea Level Rise Assessment Report by December 1, 2010. This report is required to provide (1) relative sea level rise projections specific to California, taking into account issues such as coastal erosion rates, tidal impacts, El Niño and La Niña events, storm surge, and land subsidence rates; (2) the range of uncertainty in selected sea level rise projections (3) a synthesis of existing information on projected sea level rise impacts to State infrastructure (such as roads, public facilities, and beaches), natural areas, and coastal and marine ecosystems; and (4) a discussion of future research needs regarding sea level rise for California.

In the interim, the State of California's 2009 Draft Climate Adaptation Strategy report includes guidance to State agencies addressing climate change adaptation, and BCDC has proposed Bay Plan amendment language, which includes guidance for addressing future sea level rise scenarios associated with planning and permitting development in potentially susceptible areas. These are:

- 16 inches by 2050; and
- 55 inches by 2100.

These values represent the upper end of a reasonably conservative range of sea level rise estimates. These values are meant to ensure that projects take these estimates into account when planning infrastructure and development projects, prior to the release of the Final California Sea

Level Rise Assessment Report. These upper end estimates are not meant to serve as design criteria for initial improvements; rather, they are provided to ensure that projects take into account future potential sea level rise in their design and planning, and include adaptive management strategies and measures to accommodate such levels when and if they are reached.

- **Regional**
- San Francisco Bay Plan
- The San Francisco Bay Conservation and Development Commission has promulgated the *San Francisco Bay Plan* in order to support environmental protection of San Francisco Bay in consideration of the Bay as a valuable natural asset (see Chapter III, Plans and Policies, pp. III.9-III.12). The following policies contained in the *Bay Plan* are relevant to water quality:
 - **Water Quality Policy 1:** Bay water pollution should be prevented to the greatest extent feasible. The Bay's tidal marshes, tidal flats, and water surface area and volume should be conserved and, whenever possible, restored and increased to protect and improve water quality. Fresh water inflow into the Bay should be maintained at a level adequate to protect Bay resources and beneficial uses.
 - **Water Quality Policy 2:** Water quality in all parts of the Bay should be maintained at a level that will support and promote the beneficial uses of the Bay as identified in the San Francisco Bay Regional Water Quality Control Board's Water Quality Control Plan, San Francisco Bay Basin and should be protected from all harmful or potentially harmful pollutants. The policies, recommendations, decisions, advice and authority of the State Water Resources Control Board and the Regional Board, should be the basis for carrying out the Commission's water quality responsibilities.
 - **Water Quality Policy 3:** New projects should be sited, designed, constructed and maintained to prevent or, if prevention is infeasible, to minimize the discharge of pollutants into the Bay by: (a) controlling pollutant sources at the project site; (b) using construction materials that contain nonpolluting materials; and (c) applying appropriate, accepted and effective best management practices, especially where water dispersion is poor and near shellfish beds and other significant biotic resources.
 - **Water Quality Policy 6:** To protect the Bay and its tributaries from the water quality impacts of nonpoint source pollution, new development should be sited and designed consistent with standards in municipal stormwater permits and state and regional stormwater management guidelines, where applicable, and with the protection of Bay resources. To offset impacts from increased impervious areas and land disturbances, vegetated swales, permeable pavement materials, preservation of existing trees and vegetation, planting native vegetation and other appropriate measures should be evaluated and implemented where appropriate.

Local

San Francisco Public Utilities Commission Water Pollution Prevention Program

The purpose of the San Francisco Public Utilities Commission's ("SFPUC") Water Pollution Prevention Program (Program) is to avoid and minimize pollutants entering the City's sewer system and storm drains, thereby reducing pollutant loading to San Francisco Bay and the Pacific Ocean.⁴¹ The Program includes education components for businesses, residents, and city employees. The Program also includes several initiatives that are meant to reduce water pollution, including initiatives meant to reduce toxic chemicals used for landscaping, reduce dental mercury, reduce fats/oils/greases, minimize construction-related water pollution, minimize stormwater pollution, minimize pet waste-related water pollution, properly dispose of medications, and support green design and operation measures for businesses and households.

Articles 4, 4.1, and 4.2 of the San Francisco Public Works Code contain many components of the Program.⁴² Connecting to the City's sewer system via a side sewer requires construction, including an excavation permit for a "street opening" and a side sewer permit.⁴³ One reason to have properly plumbed connections is to reduce infiltration and inflow of stormwater.

Industrial customers must pre-treat their wastewater effluent prior to discharge into the City's sewer system to reduce the pollutant demands placed on the City's system and to remove toxics or other types of pollutants that may not be captured by the City's wastewater treatment plants or that would interfere with the City's treatment processes.⁴⁴ Example limitations are that the effluent must not be too acidic or too caustic, i.e., its pH must be between 6.0 and 9.5 in any grab sample, and that total hydrocarbon oil and grease content may not exceed 100 milligrams per liter in any grab sample.⁴⁵ There are a variety of enforcement mechanisms for the industrial discharge program, including administrative orders by the General Manager of the Department of Public

⁴¹ SFPUC, "Water Pollution Prevention" web page. http://www.sfwater.org/msc_main.cfm/MC_ID/14/MSD_ID/118, accessed June 12, 2010.

⁴² Relevant portions of the Public Works Code are available through the table of contents page. <http://library.municode.com/HTML/14142/book.html>, accessed June 12, 2010.

⁴³ SF Public Works Code, Article 4, Section 105. <http://library.municode.com/HTML/14142/level1/A4.html>, accessed June 12, 2010.

⁴⁴ Article 4.1 of the SF Public Works Code governs industrial dischargers. See <http://library.municode.com/HTML/14142/level1/A4.1.html>, accessed June 13, 2010. Industries must register (Section 126), apply for permits (Section 125), pre-treat (Section 123), and monitor and report on their discharges (Section 127).

⁴⁵ SF Public Works Code, Article 4.1, Section 123.

Works, criminal penalties (such as up to 6 months in prison and \$1,000 fine, or both, for each day of each violation), and civil penalties (such as up to \$10,000 per day for each violation).⁴⁶

The Program has multiple components, such as the initiative to reduce fats, oil, and grease in the wastewater stream from commercial and residential kitchens, especially from restaurants, and the Dental Mercury Reduction Program.⁴⁷ Because fats, oil, and grease clog pipes and treatment processes, the City has recently proposed a new ordinance that would strengthen Article 4.1.⁴⁸ The Dental Mercury Reduction Program is focused on reducing discharge of dental amalgam wastes from dental offices connected to the City's sanitary sewer system to the lowest practicable level.⁴⁹ Another component is the Stormwater Management Program, which is discussed below.⁵⁰

San Francisco Public Utilities Commission Stormwater Management Plan

The SFPUC has prepared and adopted a Stormwater Management Plan⁵¹ that describes the measures that will be taken to minimize stormwater pollution. The Stormwater Management Plan is required under the Federal Clean Water Act, within NPDES Phase II regulations. The Stormwater Management Plan is applicable to those portions of San Francisco that are served by separate stormwater and sanitary wastewater systems. Therefore, because the Project Area is served by separate systems, the Stormwater Management Plan would be applicable to the Proposed Project after construction of infrastructure and acceptance by the City for public use.

The Stormwater Management Plan is composed of six program areas meant to support water quality. These program areas are: public education, public involvement/participation, illicit discharge detection and elimination, pollution prevention/good housekeeping for municipal operations, construction site stormwater runoff, and post-construction stormwater management in new developments and redevelopment areas. The Stormwater Management Plan thereby requires implementation of a variety of stormwater pollution reduction measures, including the implementation of stormwater BMPs, including construction period BMPs and long-term, post-construction BMPs. Required BMP categories mirror the six program areas discussed above: public education and outreach on stormwater impacts; public involvement/participation; illicit

⁴⁶ SF Public Works Code, Article 4.1, Sections 132 and 133.

⁴⁷ SFPUC web site, "Fats, Oils & Grease (FOG) Program," http://sfwater.org/mto_main.cfm/MC_ID/14/MSC_ID/118/MTO_ID/229, accessed June 13, 2010.

⁴⁸ See <http://sfwater.org/Files/Other/FOGOrdinanceSFPUC022510post.pdf>, accessed June 13, 2010.

⁴⁹ See http://sfwater.org/mto_main.cfm/MC_ID/14/MSC_ID/118/MTO_ID/228, accessed June 13, 2010.

⁵⁰ See SF Public Works Code, Article 4.2, available at <http://library.municode.com/HTML/14142/level1/A4.2.html>, accessed June 13, 2010.

⁵¹ San Francisco Public Utilities Commission, Stormwater Management Plan. City and County of San Francisco. January 2004. (Hereinafter "2004 Stormwater Management Plan.") http://sfwater.org/mto_main.cfm/MC_ID/14/MSC_ID/361/MTO_ID/542, accessed June 20, 2010.

discharge detection and elimination; construction site stormwater runoff control; post-construction stormwater management in new development and redevelopment; and pollution prevention/good housekeeping for municipal operations.⁵²

- Stormwater Management Ordinance and Stormwater Design Guidelines

The San Francisco Public Utilities Commission and the Port of San Francisco together developed Stormwater Design Guidelines in 2009. These guidelines describe the requirements for stormwater management in San Francisco, and provide details to help developers comply with San Francisco's stormwater handling and treatment requirements. The Stormwater Design Guidelines serve to implement the General NPDES Stormwater Permit under Phase II regulations, which require that stormwater be treated to the maximum extent practicable. The Stormwater Design Guidelines are applicable to portions of San Francisco that are served by separate storm sewers that discharge directly to local lakes or San Francisco Bay, including Treasure Island under the Proposed Project.

- Under the Stormwater Management Control Ordinance,⁵³ every development project must have a stormwater control plan that meets the criteria in the Stormwater Design Guidelines.⁵⁴ The Ordinance provides for inspections, sampling, notification regarding spills, and enforcement.⁵⁵

San Francisco General Plan

The *San Francisco General Plan* Environmental Protection Element includes objectives and policies that are relevant to the Proposed Project. These include measures that are meant to improve water quality in the San Francisco Bay and the Pacific Ocean, improve sewage treatment, reduce water pollution, and encourage water recycling.

The Environmental Protection Element includes the following key Objectives and Policies related to hydrology and water quality:

- Objective 3: Maintain and improve the quality of the Bay, Ocean, and shoreline areas.
 - Policy 3: Implement plans to improve sewage treatment and halt pollution of the Bay and Ocean.
- Objective 6: Conserve and protect the fresh water resource.
 - Policy 2: Encourage and promote research on the necessity and feasibility of water reclamation.

⁵² 2004 Stormwater Management Plan.

⁵³ Ordinance No. 83-10 (amending the San Francisco Public Works Code). See SFPUC, Stormwater Design Guidelines web page. http://www.sfwater.org/mto_main.cfm/MC_ID/14/MSD_ID/361/MTO_ID/543, accessed June 16, 2010. The Stormwater Control Ordinance is available via a link at the top of this web page.

⁵⁴ Stormwater Control Ordinance, Section 147.2.

⁵⁵ Stormwater Control Ordinance, Section 147.4.

IMPACTS

SIGNIFICANCE CRITERIA

The City and County of San Francisco has not formally adopted significance thresholds for impacts related to hydrology and water quality. The Planning Department Initial Study Checklist form provides a framework of topics to be considered in evaluating potential impacts under CEQA. Implementation of a project could have potentially significant impacts related to hydrology and water quality, including drainage and flooding, if it were to:

- Violate a water quality standard or waste discharge requirement, or otherwise substantially degrade water quality;
- Substantially deplete groundwater supplies or interfere substantially with groundwater recharge such that there would be a net deficit in aquifer volume or a lowering of the local groundwater table level (e.g., the production rate of pre-existing nearby wells would drop to a level which would not support existing land uses or planned uses for which permits have been granted);
- Substantially alter the existing drainage pattern of the site or area, including through the alteration of the course of a stream or river, in a manner that would result in substantial erosion or siltation on- or off-site;
- Substantially alter the existing drainage pattern of the site or area, including through the alteration of the course of a stream or river, or substantially increase the rate or amount of surface runoff in a manner that would result in flooding on- or off-site;
- Create or contribute runoff water which would exceed the capacity of existing or planned stormwater drainage systems or provide substantial additional sources of polluted runoff;
- Otherwise degrade water quality;
- Place housing within a 100-year flood hazard area as mapped on a Federal Flood Hazard Boundary or Flood Insurance Rate Map or other flood hazard delineation map;
- Place within a 100-year flood hazard area structures which would impede or redirect flood flows;
- Expose people or structures to a significant risk of loss, injury or death involving flooding, including flooding as a result of the failure of a levee or dam;
- Inundation by seiche, tsunami, or mudflow; and
- Expose people or structures to increased risk of flooding due to climate-induced sea level rise.

The following analysis considers water-related effects that would occur within the Project Area, and, as relevant to specific impacts or specific elements of the Proposed Project, potential effects that could occur in San Francisco Bay.

ANALYSIS APPROACH AND PROPOSED FACILITIES

The following analysis considers information contained in Chapter II, Project Description, as well as additional, more detailed information regarding proposed stormwater management, the proposed wastewater treatment plant, proposed grading improvements to alleviate flooding, and future potential sea level rise and adaptive management. These features would be implemented under the Proposed Project, and are therefore included in the subsequent impact analysis. Many of the features serve to address potential water quality or other hydrologic resources impacts as a component of project design. Additional details about facilities and management operations included in the Proposed Project that are relevant to the analysis for hydrologic resources, water quality, and flooding are described below.

Proposed Stormwater Management System

The Proposed Project includes provisions for managing stormwater as part of the Development Plan. In order to comply with State regulations and local requirements regarding water quality, and also to ensure that the release of urban-related stormwater pollutants into San Francisco Bay is reduced to the maximum extent practicable, an array of stormwater Best Management Practices (“BMPs”) have been incorporated into the design of the Proposed Project. BMPs have been selected based on the characteristics of proposed development conditions, as relevant to different stormwater watersheds on Treasure Island (see Figure IV.K.6: Treasure Island Stormwater Treatment Areas, in Section IV.K, Utilities and Service Systems, p. IV.K.35) and the watershed planning areas on the Yerba Buena Island portions of the Development Plan Area. The proposed stormwater management system is also discussed in Chapter II, Project Description, pp. II.65-II.66, and in Section IV.K, pp. IV.K.28-IV.K.37. The discussion of the proposed stormwater management system below is in addition to other information in the EIR, and is tailored specifically to the hydrology and water quality analysis.

Treasure Island

Stormwater Wetland

A 10- to 15-acre treatment wetland would be located in the northeast corner of Treasure Island. The wetland area would serve as a stormwater treatment area during the rainy months and provide a smaller permanent pool as a wildlife habitat area for Treasure Island year round. The size would be based on the treatment requirements for discharge of stormwater set by the RWQCB in compliance with the City’s NPDES discharge permit and in consultation with the SFPUC and its *Stormwater Design Guidelines*. The final location and configuration of the wetland would depend on a number of factors, including size relative to contributing watersheds,

soil contamination, groundwater,⁵⁶ public access, open space plans, and storm drainage infrastructure design.⁵⁷ The conceptual location and layout for the wetland is shown on Figure IV.K.5: Proposed Stormwater Treatment Wetland, in Section IV.K, Utilities and Service Systems, p. IV.K.31.

The wetland system would be designed to treat 90 percent of average annual runoff on a volumetric basis (i.e., 0.75 inches per unit area). Stormwater would be retained for treatment for a minimum of 48 hours. Stormwater would enter the wetland system through a series of bays with lift stations. It would first encounter sedimentation forebays that would collect trash, debris, and larger sediments. The forebays would also provide a place to clean up dry-season contamination or spills before they enter the rest of the system. Flow out of the forebays would be controlled by a weir structure.

The flow would proceed through low-flow channels and swales to the permanent pool. The permanent pool would promote both aerobic and anaerobic zones to enhance pollutant removal. The recommended minimum permanent pool size is twice the treatment volume. Based on current estimates, it would be between 3 and 6 acres, with a minimum depth of 5 feet.

Public Streets

All runoff from public streets would be treated using street-side bioretention areas. Water passing through bioretention areas would either be conveyed through the stormdrain system to the Bay or to the stormwater wetland, depending on the location. Other BMPs would treat stormwater after water has infiltrated through street-side bioretention areas. Components of this treatment train include other bioretention areas, swales, or the stormwater wetland depending on the location of the watershed.

Mixed Use Urban Core and Marina District

This watershed has been identified as a distinct treatment area based on a variety of factors including land use, building density, presence of historic structures, proximity to the edge of Treasure Island, and project phasing. It is located along the shore of Clipper Cove and the southwestern shoreline of Treasure Island at the Ferry Terminal. The larger public spaces between buildings in this area allow for a range of treatment measures to be integrated with the design of the public realm. The full range of BMPs has been selected for this area. Runoff from this area is not proposed to drain to the stormwater wetland. Instead, runoff would be treated using street-side bioretention areas before discharging to the Bay. One or more of the following

⁵⁶ For example, excavation for wetlands and ponds may be limited by the presence of contaminated groundwater at Site 24, known as the Dry Cleaning Facility. See Section IV.P, Hazards and Hazardous Materials, for discussion of contamination and its remediation.

⁵⁷ *Infrastructure Update*, Chapter 10, Addendum #1, May 11, 2009, p. 1.

BMPs could be implemented in this area: *Bioretention, Vegetated Swale, Vegetated Buffer Strip, Infiltration Trench, Permeable Pavement, Vegetated Roofs, and Rainwater Harvesting (where feasible)*.⁵⁸

Elementary School Site

The elementary school site would provide a substantial amount of space for on-lot stormwater treatment. This area is currently planned as a self-treating area (that is, an area where stormwater flows would be treated separately from the stormwater wetland); however, given its location, runoff could also drain to the stormwater wetland. One or more of the following BMPs would be implemented in this area: *Bioretention, Constructed Wetland, Vegetated Swale, Vegetated Buffer Strip, Infiltration Basin, Infiltration Trench, Permeable Pavement, and Rainwater Harvesting (where feasible)*.

Wastewater Treatment Plant

The wastewater treatment plant site is considered a self-treating area: the stormwater wetland would not treat stormwater runoff generated at the treatment plant site. BMPs that could be implemented in this area include the following: *Bioretention, Constructed Wetland, Vegetated Swale, Vegetated Buffer Strip, Infiltration Basin, Infiltration Trench, Permeable Pavement, Vegetated Roofs, and Rainwater Harvesting (where feasible)*.

Residential Areas

Residential areas on Treasure Island would be located at various distances from the stormwater wetland. For areas closer to the wetland, discharge would flow via gravity feed to the stormwater treatment wetland. For areas farther away from the treatment wetland, stormwater would be pumped to the wetland via force mains, or would be treated locally, as discussed in the next paragraph.

For residential blocks in and adjacent to the main waterfront parks, stormwater would be treated locally. The City South Residential area (the southern portion of the Cityside District) would be located at sufficient distance from the stormwater wetland that a localized stormwater treatment train is proposed in its place. In this area, street runoff would first pass through street-side bioretention areas before joining runoff from the residential areas. This combined runoff would then be conveyed by gravity and pumps to bioretention areas or vegetated swales located in the Cityside Waterfront Park. Treatment flows from impervious areas associated with vertical

⁵⁸ Christian Nilsen and Chris Guillard, PWA, memorandum on “Treasure Island stormwater treatment update and supplementary materials,” December 2009, describes these and other BMPs on pp. 5-6. A copy of this document is available for public review at the San Francisco Planning Department, 1650 Mission Street, Suite 400, in Case File No. 2007.0903E.

development parcels would also be conveyed to bioretention areas or vegetated swales located in the Eastern Shoreline Park.

Treatment of runoff from streets and vertical development parcels in the North and East residential areas (the northern portion of Cityside and most of the Eastside District) would be collected and conveyed via gravity and pumps to the stormwater wetland for treatment. Stormwater from the Job Corps campus area would be combined with residential area runoff and treated in the Waterfront Park/Eastern Shoreline Park, or the stormwater wetland area. Additional BMPs would be incorporated within the vertical development parcels and buildings; however, these additional BMPs would be considered supplemental additions to the treatment train and would not be required for regulatory compliance, except in cases where adequate treatment would not be provided by the wetlands, in streets, or other horizontal infrastructure.

Urban Agricultural Park, Sports Park and General Open Space Areas

Impervious surfaces in the Urban Agricultural Park, Sports Park, and general open space areas would be limited to small building roofs, trails, and streets associated with the open spaces. These areas are preliminarily identified as self-treating areas; however, like the elementary school site, these areas could allow runoff to drain to the stormwater wetland. No treatment BMPs are expected to be required at the pervious surfaces of the Urban Agricultural Park. However, measures to control the source of pollutants would be required, such as measures for erosion control, pesticide control, and nutrient management. One or more of the following BMPs would be implemented in these areas: *Bioretention, Constructed Wetland, Vegetated Swale, Vegetated Buffer Strip, Infiltration Basin, Infiltration Trench, Permeable Pavement, Vegetated Roofs, and Rainwater Harvesting (where feasible)*.

Yerba Buena Island

Due to the topography on Yerba Buena Island, watersheds are not expected to be able to maintain a functioning stormwater wetland. Therefore, constructed wetlands are not proposed on Yerba Buena Island. However, the remaining menu of BMPs would be employed as appropriate, as discussed below.

Public Streets, Roads, and Parking Areas

Runoff from all public streets and roads would be treated through bioretention or vegetated swales. Due to steep slopes and narrow rights-of-way, bioretention areas are generally not feasible within the street sections on Yerba Buena Island. Instead, runoff would be collected and conveyed to bioretention areas located in larger, less steep areas at lower elevations. Locating bioretention areas at the lower elevations would provide the added benefit of reducing infiltration on steeper, less stable slopes, thereby reducing erosion and risks associated with slope stability.

Distributed but relatively consolidated bioretention areas would also reduce maintenance costs and potential erosion issues. Specific measures that would be implemented include the following: *Bioretention, Stepped Cells, Flow Control Weirs, and Street-Side Vegetated Swales.*

Housing and Hotel Parcels

Stormwater treatment BMPs would be incorporated in the housing and hotel parcels to the maximum extent practicable as part of a treatment train approach. Treatment flows would then be conveyed in surface or subsurface storm drainage systems for further treatment in the downstream treatment areas. Permeable pavements, vegetated roofs, and other source reduction measures may also be considered as part of the stormwater treatment approach in this area; however, the proposed system does not rely on these practices. Permeable paving areas would include sub-drainage systems, as required, to ensure road and slope stability. Infiltration BMPs have been excluded from use in this area to reduce risks associated with slope stability and foundation design. The following BMPs would be employed: *Bioretention, Vegetated Swale, Vegetated Buffer Strip, Permeable Pavement, Vegetated Roofs, and Rainwater Harvesting (where feasible).*

Existing Historic Buildings and Site Areas

Stormwater BMPs that serve the existing historic buildings on Yerba Buena Island would be integrated into the landscape, most likely at a small scale. Generally, these structures, including the Nimitz House and adjacent “Great Whites,” are designated historic structures that would require sensitive integration of appropriate BMPs to address stormwater treatment requirements. BMPs available for the existing buildings and site areas include the following: *Bioretention, Vegetated Swale, Vegetated Buffer Strip, Permeable Pavement, Vegetated Roofs, and Rainwater Harvesting (where feasible).*

Open Space Areas

Impervious surfaces in open space areas on Yerba Buena Island would be limited to trails, overlook points, and small picnic areas at Hilltop Park and recreation trails. BMPs to treat runoff in these areas may include the following: *Bioretention, Vegetated Swale, Vegetated Buffer Strip, Permeable Pavement, Vegetated Roofs, and Rainwater Harvesting (where feasible).*

Proposed Wastewater Treatment Plant

The wastewater treatment plant would be upgraded or replaced on or near the site of the existing wastewater treatment plant, and operated by the SFPUC. Treated effluent would continue to be discharged through the existing outfall structure to the Bay. The existing NPDES permit, discussed on p. IV.O.9, would be updated when the treatment plant is upgraded or replaced. The

updated NPDES permit would reflect the types of treatment processes that would be implemented.

The proposed wastewater treatment plant would be completed according to one of several potential options that are under consideration. Under all options, a baseline treatment system with the following components would be installed:

- Headworks and primary sedimentation;
- Trickling filter and solids contact;
- Microfiltration and reverse osmosis (for recycled water only); and
- UV disinfection.

Two wetland variants are being considered, as described in Chapter VI, Variants, Section D, Wastewater Wetlands Variants, pp. VI.38–VI.39. Under the first option, Constructed Wetland for Tertiary Treatment, following secondary treatment, water would be routed through a series of specially constructed wetlands for tertiary treatment. Following treatment in the wetland, effluent to be used for irrigation would be treated by microfiltration and reverse osmosis, as well as UV disinfection. Under the second option, Constructed Wetland for Polishing, the portion of the disinfected effluent that is not recycled would flow to the constructed wetland for polishing and then to the treatment plant outfall. Here, the wetland would receive water that has been treated by UV disinfection. Recycled water would also be treated using reverse osmosis and microfiltration, as needed.

Proposed Flood Improvements

Flood improvements for the Proposed Project would be associated primarily with raising existing grades and ground levels, using engineered fill, to levels that are above the flooding and wave run-up zones.

Treasure Island Proposed Building Areas

For proposed building areas, the Proposed Project would include raising Treasure Island base elevations to be above the preliminary Zone A floodplain (that is, the 100-year flood zone), plus accommodating 36 inches of sea level rise plus an additional 6 inches of freeboard. Therefore, the minimum finished floor elevations and garage entrances for the proposed buildings would be set at 12.6 feet NAVD88. Final finished floor elevations would likely range from 12.6 feet to 14.5 feet NAVD88.

Treasure Island Open Space Areas

Minimum elevations for open space areas would be set equal to base flood elevation, which is 9.1 feet NAVD88. Lower portions of open space areas may experience localized flooding

associated with large rain events occurring simultaneously with 100-year tides. Depth of the ponds that form in the Great Park open space during these events would be minimal, and the temporary ponds would last for up to approximately 2 hours. Under the 36-inch sea level rise scenario, pump stations added to the storm drain system would reduce ponding depth in open space areas.

Treasure Island Existing Historic Buildings and Job Corps Structures to Remain

The existing finished floor elevations for these structures range in elevation from 11.0 to 12.5 feet NAVD88. These finished floors and the immediately surrounding ground areas would not be raised as part of the Proposed Project. These existing elevations are sufficient to maintain the buildings outside of proposed FEMA Zone A designations for current tide conditions, and for much of the 36-inch sea level rise scenario. In the event that sea level rise were to affect the base flood elevation such that base flood elevation plus sea level rise would be above the finished floor level, local improvements around the buildings and pump stations would be used to protect these facilities.

Yerba Buena Island Flooding Upgrades

Because Yerba Buena Island has steep and high grades in comparison to Treasure Island, it is anticipated that Yerba Buena Island would not require additional engineered fill or other flood protection measures, unlike those needed for Treasure Island.

Future Potential Climate-Induced Sea Level Rise

Moffatt and Nichol⁵⁹ conducted a complete review of the most widely published and scientifically credible literature regarding future potential sea level rise in the *Treasure Island Coastal Flooding Study*. This report summarizes the results of eight peer-reviewed documents that are the most widely recognized as credible sources in the scientific community, and are widely accepted as the most relevant to the specific subject of future potential sea level rise projections. Almost all of the reviewed documents were sponsored by a government entity or organization. The report provides a summary of these documents related to sea level rise, and recommends an adaptive management strategy to address future potential sea level rise.

Moffat and Nichol also reviewed works of independent authors (not published by an organization) that are illustrative of ongoing development in the climate science community.⁶⁰ Although relevant information from these studies was used in developing project-specific sea level rise recommendations, the studies were not summarized in the *Coastal Flooding Study*, because most of these publications do not include specific analysis of sea level rise; instead, they

⁵⁹ Coastal Flooding Study 2009.

⁶⁰ Coastal Flooding Study 2009.

present observations of ice sheet melt rates, carbon dioxide (CO₂) levels, temperature changes, among other factors, along with empirical or hypothetical projections of sea level rise.

The science of estimating sea level rise continues through a stepwise process of refinement, and additional research will provide better estimates in the future. For instance, since publication of Moffatt and Nichol's study in 2009,⁶¹ new documents have continued to be published that discuss sea level rise in some way.⁶² The analysis presented here provides a summary of the most reasonable range of sea level rise estimates.

Future potential sea level rise associated with climate change may pose risks of inundation to existing and proposed development located in low-lying areas close to San Francisco Bay, including Treasure Island and low-lying areas of Yerba Buena Island. Periodic flooding could occur as a result of climate-induced increases in the level of San Francisco Bay waters, combined with other factors such as tidal cycles, storm surge, wind waves and swell, or seismic waves.

The rate of potential future sea level rise is difficult to project, and estimates vary substantially among the thousands of scientific research documents available on climate change and sea level rise. Based on the most widely accepted literature, the following examples provide a reasonable range of low, medium, and high estimates of future potential sea level rise that could likely occur.

1. **Low Rate of Increase:** The rate of future potential sea level rise could occur according to the low end of the range of sea level rise projections for the emissions scenarios presented in the Fourth Assessment Report by the Intergovernmental Panel on Climate Change.⁶³ Relative to sea levels in the year 2000, sea level is projected to rise 3 inches by 2050, and 12 inches by 2100.
2. **Medium Rate of Increase:** The rate of future potential sea level rise could occur according to estimates by the California Climate Change Center,⁶⁴ which indicate that sea level is projected to rise by up to 35 inches by 2100. This is similar to mid-range projections made by Rahmstorf.⁶⁵
3. **High Rate of Increase:** Future potential sea level rise could occur at a higher rate, possibly resulting in an increase of 16 inches by 2050, and 55 inches (or higher) by 2100. These values have been cited by both BCDC in its *Living with Rising Seas* report and the State of California in its *2009 Draft Climate Adaptation Strategy*. Both reports

⁶¹ Coastal Flooding Study 2009.

⁶² Moffatt and Nichol, Memorandum from Dilip Trivedi to Alex Galovich, "Treasure Island Sea Level Rise Literature Update," April 19, 2010. A copy of this document is available for public review at the San Francisco Planning Department, 1650 Mission Street, Suite 400, in Case File No. 2007.0903E.

⁶³ Intergovernmental Panel on Climate Change. *Climate Change, 2007: The Physical Science Basis. Contribution of Working Group 1 to the Fourth Assessment Report of the Intergovernmental Panel on Climate Change*. Solomon, S., D. Qin, M. Manning, Z. Chen, M. Marquis, K.B. Averyt, M. Tignor, and H.L. Miller (eds). Cambridge University Press.

⁶⁴ California Energy Commission. *The Future Is Now: An Update on Climate Change Science Impacts and Response Options for California*. May 2009. CEC-500-2008-071.

⁶⁵ Rahmstorf, S. "A semi-empirical approach to projecting future sea-level rise," *Science Magazine* 315: 368-370, 2007.

recommend using this upper end of the range as guidance to local and State agencies planning for sea level rise, and are consistent with recent predictions made by the Pacific Institute.⁶⁶ See “Sea Level Rise and Executive Order S-13-08” in “Regulatory Framework,” p. IV.O.19.

Other factors, including nonlinear effects associated with potential instability of the Greenland and Antarctic ice sheets, have also been discussed in the literature. However, the potential contributions to future sea level rise from ice melt have not been definitively established, and such factors in general are not considered in the sea level rise assessments summarized above.

Elements Included in the Proposed Project to Accommodate the Potential for Sea Level Rise

The Proposed Project includes three major elements for Treasure Island to accommodate future potential sea level rise:

- Improvements that would be made as part of the initial Development Plan;
- Implementation of a long-term adaptive management strategy, which would include future improvements as needed to accommodate actual sea level rise as it develops; and
- Periodic reporting on the status of the Proposed Project’s adaptive management strategy.

Each of these elements is described below. The Proposed Project’s Disposition and Development Agreement would also describe these elements and how the Proposed Project would implement each of them.

Immediate Improvements and Protective Measures

The Proposed Project includes several protective measures to be implemented as part of the construction of the Development Plan’s improvements on Treasure Island:

- The perimeter berm would be raised where necessary to prevent significant wave overtopping onto the perimeter open space during storm events, for up to 16 inches of sea level rise from present-day sea levels.
- The elevation of all new building pads, streets, and vital infrastructure within the Development Plan Area would be raised to be between 36 and 42 inches above the current 100-year high tide elevation. The raised elevation would provide protection to the new development footprint areas to accommodate up to 36 inches of sea level rise from present-day levels.
- The storm drainage system designs would accommodate up to 16 inches of sea level rise. It also includes provisions for storm drain pump stations to be installed in the future, if required and/or desired (as described in more detail below).

⁶⁶ Heberger M., Cooley H., Herrera P, Gleick P, and Moore E., The Impacts of Sea-Level Rise on the California Coast. May, 2009. CEC-500-2009-024-F.

These improvements and protective measures represent a baseline for an adaptive management strategy, discussed below, that would be implemented to proactively address future potential sea level rise.

Adaptive Management Strategy

After initial improvements are completed, TIDA would be responsible for overseeing the management and implementation of an adaptive management strategy. The adaptive management strategy would include, but not be limited to, the following activities:

- An ongoing monitoring program to review sea level rise data;
- A decision-making framework for future improvements to protect Treasure Island from potential flooding due to sea level rise;
- A mechanism for collecting and administering project-generated funds to pay for the costs of the adaptive management program.

Each of these activities is described below. TIDA would issue periodic reports on the status of the adaptive management strategy.

Monitoring Program

The Proposed Project would create a monitoring program to review and synthesize sea level rise estimates prepared for San Francisco Bay by the National Oceanic Atmospheric Administration and/or a State agency. TIDA would also conduct a periodic review of scientific literature for updated sea level rise estimates.

Decision-making Framework

If the data from the monitoring program demonstrate that sea level rise in San Francisco Bay has exceeded (or will soon exceed) the allowances designed for in the initial improvements, a range of additional improvements could be made to protect the island from flooding and periodic wave overtopping. Decisions on which improvements to make would be made by TIDA at the time improvements are required; the decision as to which solutions to implement would likely depend on a variety of factors, including, but not limited to, consultation with the SFPUC and other local agencies; any new local, State, or Federal requirements⁶⁷ about how to address sea level rise; available technology and industry best practices at the time; and both the observed rate of actual sea level rise and updated estimates of future sea level rise.

⁶⁷ Currently, there are a number of ongoing efforts to study and plan for sea level rise in California. These include efforts by the State, as required by Executive Order S-13-08, and by the National Academy of Sciences as requested by the Governor of California.

Based on the best information available today, the anticipated thresholds and associated adaptive strategies are as follows:

- *Sea level rise up to 16 inches:* Due to the set of initial protective measures implemented as described above, no adaptations would be required.
- *Sea level rise between 16 to 36 inches:* If the 100-year high tide elevation increases by more than 16 inches, storm drain pump stations would be constructed at some or all of the storm drain outfalls, in coordination with the SFPUC. The pump stations could also be designed to accommodate additional sea level rise, if prudent.

In addition, along the perimeter berm areas it is expected that there would be increasing incidents of wave overtopping, particularly along the western and northern shorelines. Such wave overtopping could result in ponding along the perimeter areas during storm events. The Proposed Project's initial design grading and drainage designs would accommodate such ponding, and the storm drains would be designed to enable drainage to occur within 1 to 3 hours after the high tide, depending on the amount of ponding. However, if sea level continues to rise and overtopping and ponding continue to increase, TIDA may determine that these incidents are adversely affecting beneficial use of the shoreline areas. In this event, TIDA could elect to make improvements to address the problem. Such improvements could include:

- Installing additional storm pumps in locations (if any) not already required to meet the SFPUC storm drainage requirements, in order to drain water more quickly;
 - Changing the shape of the perimeter berm to make it less steep. This could include modifying the shoreline to create cobblestone or sand beaches, or creating tidal wetlands, either of which would limit wave run-up and overtopping;
 - Raising the perimeter to function as a storm surge and flood barrier or levee;
 - Constructing a series of embankments of increasing heights inland from the shoreline. Land between sets of embankments can hold periodic wave overtopping that would drain out between high tides; and/or
 - Constructing sea walls. This solution may be particularly appropriate at the Ferry Terminal and along Clipper Cove, where development is relatively closer to the island perimeter.
- *Sea level rise above 36 inches:* In the event 36 inches of sea level rise were to occur, the new building pads and infrastructure would be in the floodplain and would require additional flood protection. Prior to 36 inches of sea level rise having occurred, TIDA would implement additional improvements around the island perimeter. These improvements would serve to protect the interior of the island from flooding due to higher sea levels, including storms and high waves. The design of the island as currently proposed, including the fact that development would be set back from the perimeter, would give TIDA the ability to implement a variety of different flood protection options, including, but not limited to, the following:
 - Raising the perimeter to function as a storm surge and flood barrier or levee;
 - Constructing a series of embankments of increasing heights inland from the shoreline; and/or
 - Constructing sea walls.

Funding Mechanism

The Proposed Project would include a mechanism to create project-generated funding that would be dedicated to paying for the flood protection improvements necessary to implement the adaptive management plan. Such funding mechanisms could include allocation of a portion of the Mello-Roos tax assessments or a dedicated tax assessment. The funding would be sized to cover the anticipated costs of such improvements.

Reporting Requirements

TIDA would be responsible for periodically preparing a report on the progress of the adaptive management strategy. The report would be prepared no less than every 5 years, or more frequently if required by regulators. The report would include:

- The publication of the data collected and literature reviewed under the monitoring program;
- A review of any changes in the local, State, or Federal regulatory environment related to sea level rise, and a discussion of how the Proposed Project is complying with any new regulatory requirements;
- A discussion of the improvements recommended to be made if sea levels reach the anticipated thresholds identified above in “Decision-making Framework” within the next 5 years; and
- A report of the funds collected for implementation of the adaptive management strategy, and a projection of funds anticipated to be available in the future.

PROJECT IMPACTS

Construction Impacts

**Impact HY-1: The Proposed Project would not violate a water quality standard or a waste discharge requirement, or otherwise substantially degrade water quality.
(Less than Significant)**

During construction, the use of heavy equipment, including bulldozers, graders, earth movers, trucks, backhoes, piledrivers, and other equipment, would disturb surface soils. Additionally, the use of construction equipment could result in the release of greases, oils, coolants, hydraulic fluid, fuels, cement washout, and other construction-related contaminants into the environment. As a result, stormwater could become contaminated by elevated sediment levels, or by elevated levels of other construction-related pollutants. Construction activities near or in the Bay, such as those for the proposed Ferry Terminal, which would be located within San Francisco Bay, could release contaminants directly into Bay waters, resulting in increased pollutant loading. Landside construction activities could cause contaminants to infiltrate into groundwater, or become entrained in surface flows and eventually discharged into San Francisco Bay, resulting in

degraded water quality. As a condition of construction, the applicant would be required to obtain coverage under the NPDES General Construction Permit for Discharges of Stormwater Associated with Construction Activities (“NPDES General Permit”), under the RWQCB. As discussed in “Regulatory Framework,” p. IV.O.15, permit requirements would include the following or equivalent measures:

- Preparation of a site-specific SWPPP;
- Preparation of hazardous material spill control and countermeasure programs;
- Stormwater quality sampling, monitoring, and compliance reporting;
- Development and adherence to a Rain Event Action Plan;
- Adherence to numeric action levels and effluent limits for pH and turbidity; monitoring of soil characteristics on site;
- Mandatory training under a specific curriculum; and
- Mandatory implementation of BMPs, which could include, but would not be limited to, the following as relevant to the location and type of construction activity:
 - Physical barriers to prevent erosion and sedimentation including setbacks and buffers, rooftop and impervious surface disconnection, rain gardens and cisterns, and other installations;
 - Construction and maintenance of sedimentation basins;
 - Limitations on construction work during storm events;
 - Use of swales, mechanical, or chemical means of stormwater treatment during construction, including vegetated swales, bioretention cells, chemical treatments, and mechanical stormwater filters; and
 - Implementation of spill control, sediment control, and pollution control plans and training.

Adherence to these and/or other similar BMPs would be required as a condition of the permit, and would substantially reduce or prevent waterborne pollutants from entering natural waters, per RWQCB standards. The specific set of BMPs would be determined based on the final design and construction schedule prior to initiation of construction activities. Specific BMPs would be implemented based on final construction drawings and are subject to review and approval by the RWQCB and the SFPUC. A schedule for implementation, as well as a series of monitoring and compliance measures, would be developed in coordination with the permitting agency, to meet Clean Water Act standards. Therefore, additional mitigation for stormwater quality is not required to protect water quality during landside construction, over and above that required by the NPDES General Construction Permit. The potential for encountering sediments during construction and mitigation measures that address this issue are discussed in Section IV.P, Hazards and Hazardous Materials.

Construction of a new Ferry Terminal would include dredging and the installation of two breakwaters in San Francisco Bay, directly adjacent to Treasure Island. Construction of the Treasure Island Sailing Center launch facilities would also include a small amount of dredging. Dredging would disturb the Bay's bottom sediments and could release sediment and other dredged materials into Bay waters, the Pacific Ocean, or to an area or project slated for reuse of dredge materials, pursuant to the LTMS Management Plan. Permits for the disposal of dredge materials would be required in order to comply with the LTMS Management Plan for the management of dredge materials. Installation of the proposed breakwaters could also disturb bottom sediments and potentially increase turbidity in Bay waters during construction. The following permits would be required for the construction of the Ferry Terminal and construction of the Sailing Center launch facilities: BCDC Dredging Permit; U.S. Army Corps of Engineers Permit for dredging; and Clean Water Act Section 401 Water Quality Certification issued by the RWQCB, as managed via the DMMO and individual permitting agencies. Together, these permits would implement a series of requirements for dredging and in-water construction, as discussed in "Long Term Management Strategy for the Placement of Dredged Material in the San Francisco Bay Region, Management Plan 2001," pp. IV.O.18-IV.O.19. These requirements include preliminary and ongoing testing of dredge materials, constraints on dredge machinery and dredging work periods based on biological resources, and completion of a detailed alternatives analysis that identifies and supports implementation of alternatives to aquatic disposal of dredge materials. These alternatives may include upland disposal, on-site use, or wetland enhancement. Additionally, the application of dredging BMPs would be required under the indicated permitting scheme. BMPs may include, but would not be limited to, the following:

- - Gunderbooms to filter and reduce sediment;
 - Mechanical dredge operational controls, including increased cycle time, elimination of multiple bites, and elimination of bottom stockpiling;
 - Hydraulic dredge operational controls, including reduction of cutterhead speed, reduction of swing speed, and eliminate bank undercutting;
 - Hopper dredges and barge operational controls;
 - Elimination or reduction of hopper overflow, lowering of hopper fill level, or use of a hopper overflow recirculation system;
 - Use of specialty equipment including pneuma pumps, closed buckets, large-capacity dredges, and use of precision dredging; and
 - Work window restrictions to avoid impacts on sensitive resources.

Implementation of these BMPs along with the other permit conditions described above would minimize the potential release of contaminants and sediments contained in dredge materials and associated with dredge operations. Project-related dredging would not proceed until all permits (and applicable consultations for biological resources) are complete; therefore, this impact would be less than significant, and no mitigation is required.

Impact HY-2: The Proposed Project could require disposal of dewatered groundwater during construction. (*Less than Significant with Mitigation*)

Near-surface groundwater is located in many portions of the Development Plan Area, including all of Treasure Island and low-lying portions of Yerba Buena Island (e.g., near the Coast Guard Station and Sector Facility). Construction of new facilities would require excavation in these areas for below-grade infrastructure such as pipelines, drainage facilities, and building foundations, and temporary dewatering of groundwater could be necessary. Groundwater removed during dewatering is likely to contain elevated suspended sediment concentrations and, depending on location, may also contain other water quality pollutants, such as elevated salinity. This issue is discussed further in Impact HZ-1 and Mitigation Measure HZ-1, in Section IV.P, Hazards and Hazardous Materials, pp. IV.P.39-IV.P.43. Groundwater removed during dewatering could contain entrained harmful pollutants that are currently contained in subsurface soils and groundwater, including hydrocarbons, VOCs, low-level radiological waste, dioxins, pesticides, PCBs, lead and other metals, dry cleaning chemicals, and various other contaminants.

As discussed in Section IV.P, p. IV.P.41, prior to initiation of construction activities, implementation of Mitigation Measure M-HZ-1 would be required. Under this mitigation measure, the project sponsors would prepare a Soil and Groundwater Management Plan (“SGMP”). The SGMP would be developed to the satisfaction of the RWQCB and DTSC to sample and analyze water prior to dewatering and would provide options for disposal of this water based on the sampling results. These options could include the following: (1) Re-use and Discharge: If groundwater meets required thresholds under the SGMP, it can be re-used (e.g., for dust control) and discharged under the General Construction Permit; (2) Discharge under NPDES Permit: If the groundwater exceeds thresholds as described in the SGMP, a separate permit could be obtained from the RWQCB and discharged under NPDES requirements; (3) Treatment and Discharge to Sanitary Sewer: If the groundwater exceeds thresholds as described in the SGMP, groundwater could be treated as necessary and discharged to the sanitary sewer system, where it could be further treated by the on-site treatment plant; or (4) Off-site Disposal: If the groundwater exceeds thresholds as described in the SGMP, groundwater could be trucked off site for disposal in an approved facility. Compliance with the SGMP, as discussed in Section IV.P, would ensure that water effluent from dewatering activities would meet applicable RWQCB or SFPUC standards, and would therefore reduce the potential for groundwater dewatering activities to result in water quality pollution. With implementation of Mitigation Measure M-HZ-1, the impact would be less than significant.

For additional discussion of hazards related to contaminated groundwater, please see Section IV.P, Hazards and Hazardous Materials.

Impact HY-3: The Proposed Project would not substantially deplete groundwater supplies or interfere substantially with groundwater recharge during construction. (*Less than Significant*)

As discussed in Impact HY-2, the Proposed Project could require dewatering of groundwater during construction in areas with shallow groundwater. This would result in a localized, temporary reduction in groundwater levels, in close proximity to each groundwater dewatering site. Upon completion of the construction period, groundwater levels are expected to return to pre-construction levels. Additionally, because groundwater on site is not used for municipal, industrial, or residential water supply, any temporary reduction in groundwater levels during construction would not interfere with water supply wells or other groundwater uses. (The potential for reduction of groundwater levels during Proposed Project operation is discussed under Impact HY-9, p. IV.O.46.) Therefore, groundwater levels would not be significantly altered during construction, and this impact would be less than significant. No mitigation is required.

Impact HY-4: The Proposed Project would not alter the existing drainage patterns on the Islands, and would not result in substantial erosion or siltation or localized flooding. (*Less than Significant*)

There are no streams or rivers on the Islands. There are small, ephemeral natural drainages on Yerba Buena Island that provide drainage to open areas of the island. There are no natural drainages on Treasure Island; however, the island is served by a network of storm drains, as discussed previously. Storm flows in excess of existing storm drain capacity are carried overland to the edge of Treasure Island, where they discharge to San Francisco Bay.

Implementation of the Proposed Project would result in the construction of an array of new buildings, open spaces, roadways, and other facilities across Treasure Island, as well as limited facilities on Yerba Buena Island. If improperly engineered or managed, these new facilities could result in a significant alteration of existing drainage, such that localized flooding, siltation, or erosion could occur during a storm event. As discussed in “Stormwater” in Chapter II, Project Description, pp. II.61-II.66, and in this section on p. IV.O.24, the Proposed Project would include various measures to provide drainage within the Project Area, including a new storm drain system and stormwater treatment. With implementation of the improved drainage system and the proposed stormwater treatment, this impact would be less than significant.

Impact HY-5: The Proposed Project would not result in construction of housing within a 100-year flood hazard area if one is designated by FEMA. (*Less than Significant*)

As discussed in “Regulatory Framework,” p. IV.O.11, FEMA is in the process of developing flood insurance rate maps for the City and County of San Francisco, including Yerba Buena

Island and Treasure Island. Based on a preliminary FIRM issued by FEMA for review and technical comment only, portions of Treasure Island are located within a 100-year special flood hazard zone under existing conditions. The preliminary FIRM does not indicate any 100-year special flood hazard zone areas on Yerba Buena Island, except around its margin, directly adjacent to the San Francisco Bay. For Yerba Buena Island, no development is proposed within the 100-year special flood hazard zone. Therefore, there would be no impact related to construction of housing within a 100-year flood hazard area on Yerba Buena Island.

Based on the preliminary FIRM, areas of Treasure Island where development is proposed are shown as being within a preliminary 100-year special flood hazard zone under existing conditions. However, as discussed in “Proposed Flood Improvement,” p. IV.O.29, the Proposed Project would include raising base elevations of proposed building areas on Treasure Island, such that all building areas would be above the preliminary 100-year special flood hazard zone. Additionally, the Proposed Project would install engineered fill, to accommodate for 36 inches of sea level rise, with an additional 6 inches of freeboard, resulting in minimum finished floor elevations of 12.6 feet NAVD88.

In the event that the final FEMA maps indicate that a portion of the existing Development Plan Area would be located within a 100-year special flood hazard zone, the following procedure would be initiated, as discussed in “Regulatory Framework” under “Executive Order 11988,” p. IV.O.11: TIDA would apply for a CLOMR after the proposed flood improvements for Treasure Island are designed and approved. Following construction of these improvements, TIDA would apply for a final determination (LOMR). Assuming the approval of an LOMR, the elevated portions of Treasure Island would be excluded from the 100-year flood plain on FEMA maps.⁶⁸ Development of housing would be limited to areas that would be raised to above the designated 100-year special flood hazard zone in final FEMA maps; housing would not be located outside of these areas. Therefore, no significant impact would occur.

For a discussion of impacts associated with flooding and future potential sea level rise, see Impact HY-12, p. IV.O.48.

Impact HY-6: The Proposed Project would not place structures within a 100-year flood hazard area that would impede or redirect flood flows. (*Less than Significant*)

A preliminary FIRM, issued by FEMA for review and technical comment only, shows that portions of Treasure Island are currently located within a 100-year special flood hazard area. The preliminary FIRM does not indicate any 100-year flood areas on Yerba Buena Island, except

⁶⁸ If the base ground level for buildings were not raised as described above, the San Francisco Floodplain Management Ordinance would apply. It would require construction that would include protections against flooding.

around its margin, directly adjacent to San Francisco Bay. Because development on Yerba Buena Island is proposed to be outside of this zone, the Proposed Project would not place structures within the preliminary 100-year flood zone on Yerba Buena Island that would impede or redirect flood flows.

For areas of Treasure Island that could be located in the 100-year special flood hazard area, the Proposed Project would include installation of additional fill to raise low-lying portions of the island above the 100-year special flood hazard zone elevations, as well as completion of the CLOMR process according to the procedure described in Impact HY-5. During a flood event, this additional fill would result in the displacement of flood flows, which would have otherwise washed over a portion of the island. With implementation of the Proposed Project, the displaced flood flows would remain in San Francisco Bay. The volume of displaced flood flows would represent a less-than-measurable increase in floodwaters in the Bay. Thus, the effects of redirecting flood waters would not be observed elsewhere along the Bay margin.

Finally, the Proposed Project would result in installation of breakwaters and portions of the ferry quay in San Francisco Bay, as part of the proposed Ferry Terminal. These waterside facilities would be subject to variability in water levels associated with storm surge, tidal height, ocean waves, Bay-derived wind waves, and potentially tsunamis. However, installation of the proposed facilities would not divert or redirect Bay waters in such a manner that additional or altered flooding patterns would occur. This impact would be less than significant, and no mitigation is required.

For a discussion of impacts associated with flooding and future potential sea level rise, see Impact HY-12, p. IV.O.48.

Impact HY-7: The Proposed Project would not result in the exposure of people or structures to loss due to flooding associated with levee or dam failure. (No Impact)

No dams are located in the Project Area, and no dams are proposed as part of the Proposed Project. No levees are currently located in the Project Area, and none are proposed. No impact would occur. The impacts of climate change on the Proposed Project, which could include installation of protective levees as mitigation for sea level rise, are discussed in Impact HY-12, p. IV.O.48. Potential impacts associated with 100-year flood inundation are addressed under Impacts HY-5 and HY-6, pp. IV.O.39-IV.O.41.

Operation Impacts

Impact HY-8: Operation of the Proposed Project would not result in degradation of water quality. (*Less than Significant*)

Ferry Terminal Operations

During operation of the new Ferry Terminal, the proposed breakwaters could reduce currents and other flows within and adjacent to the ferry basin, resulting in potentially limited water exchange between the proposed ferry basin and San Francisco Bay. The breakwaters could contain turbidity associated with operations, but could also concentrate water quality contaminants associated with ferry usage. Moffatt and Nichol⁶⁹ completed an assessment of potential reductions in water quality resulting from installation of the proposed breakwaters under three different configurations. Results indicated that flushing time for the basin would range from 0.1 days to (at most) 7.2 days, depending on basin design and variable circulation patterns associated with currents in San Francisco Bay. This range of flushing times would be fast enough to prevent water stagnation or other reduced water quality effects. Propeller wash generated during the operation of ferries, particularly during docking activities, could stir up bottom sediments and result in increased turbidity. However, these effects would occur inside the proposed harbor area, and any increases in turbidity are expected to be limited to that area. These impacts would be less than significant, and no mitigation is required.

Ferry Quay and Shoreline Stability

Moffatt and Nichol⁷⁰ completed an assessment of potential effects on shoreline stability associated with installation of the proposed ferry quay and breakwaters. The analysis included a historical evaluation of shoreline change along the southwest shoreline of Treasure Island, and an assessment of potential changes to tidal currents in the vicinity of the proposed Ferry Terminal, evaluated via numerical model. The historical evaluation (1947-2002) indicated no evidence of sediment accretion along the southwest side of Treasure Island during the period surveyed, likely due to the area's relatively high energy wave environment, which keeps sediment particles suspended.

The numerical model completed by Moffatt and Nichol evaluated the potential for erosion or sedimentation along Treasure Island that could result from several Ferry Terminal configuration options.⁷¹ Results suggest that the potential for sediment accretion along the outer edge of the

⁶⁹ Moffatt and Nichol, Treasure Island Ferry Terminal Project, Coastal Engineering Assessment. September 2009. (Hereinafter "Coastal Engineering Assessment.") A copy of this document is available for public review at the San Francisco Planning Department, 1650 Mission Street, Suite 400, in Case File No. 2007.0903E.

⁷⁰ Coastal Engineering Assessment.

⁷¹ Coastal Engineering Assessment.

proposed breakwaters would be low. Along the proposed breakwaters for all Ferry Terminal configuration options, the tidal flood and ebb currents would decrease slightly, which could result in deposition of coarser sediment fractions around the breakwaters. However, the study concludes that these coarser sediments would likely be transported to deeper waters off of the tips of the breakwaters, and finer sediments would not be expected to settle out. On outgoing tides, the study indicates that flow would be reduced in the vicinity of the entrance to the ferry basin under the proposed breakwater alignment. Periodic maintenance dredging inside the future ferry basin would be required during project operations; the frequency of the periodic dredging would depend on the sediment accretion rate. When maintenance dredging is required, implementation of a series of BMPs to minimize the suspension of turbidity and other pollutants during dredging, and compliance with necessary permits as described in Impact HY-1, would reduce impacts to less-than-significant levels.

Ferry Terminal Wave Reflection

Moffatt and Nichol⁷² also completed an assessment of the potential for increased shoreline erosion that could occur along the margins of San Francisco Bay due to wave reflection from Ferry Terminal breakwaters, in particular along the shoreline of the San Francisco mainland. The assessment also evaluated the potential for similar effects to occur on Alcatraz Island as a function of the installation of the breakwaters at Treasure Island. The assessment indicates that, due to the direction of wave approach, combined with the relatively long distance between the Ferry Terminal breakwaters and shorelines outside of the Project Area (at least 10,000 feet), no increase in potential shoreline degradation or erosion would occur. Specifically, the magnitude of the largest waves reflected from the proposed breakwaters, under all breakwater design options, would be smaller than storm-related wind waves by the time the nearest shoreline was reached, under existing conditions. Therefore, erosion and associated reductions in water quality would not occur along the San Francisco shoreline or other nearby shorelines, and impacts would be less than significant. No mitigation is required.

Wastewater Treatment and Associated Discharges

The Proposed Project would result in the intensification of use within the Development Plan Area, resulting in an increase in the volume of wastewater discharged. As a result of implementing the Proposed Project, average dry weather wastewater flows would be anticipated to increase to about 1.3 mgd (existing dry weather flows from December 2005 through June 2009 ranged from 0.35 to 0.50 mgd, with higher flows during wet weather, as discussed on p. IV.O.9).

⁷² Moffatt and Nichol, Memorandum: Response to EIR Team Question on Coastal Engineering Assessment. Treasure Island Ferry Terminal Project. September 30, 2009. A copy of this document is available for public review at the San Francisco Planning Department, 1650 Mission Street, Suite 400, in Case File No. 2007.0903E.

In order to handle these additional flows, the Proposed Project includes a new or updated treatment plant, which would provide treatment of sanitary sewage from the Islands. (For additional discussion of these proposed facilities, please see Chapter II, Project Description, pp. II.56-II.59.) The SFPUC would be required to comply with relevant laws and approvals required for the new or upgraded treatment plant. Discharge of treated wastewater effluent would be controlled by the provisions of the most recent update to the wastewater discharge NPDES permit (NPDES Permit No. CA0110116, Order No. R2-2010-0001). (Under the Proposed Project, the SFPUC would continue to operate and maintain the wastewater treatment plant, and either the SFPUC or TIDA would become the permit holder, until such time as the wastewater treatment plant would be upgraded or rebuilt and accepted into SFPUC's system. At this point, the SFPUC would become the permit holder.) The recently revised permit allows for the discharge of up to 2.0 mgd (design flow), with a permitted peak flow, providing secondary treatment, under wet weather conditions, of 4.4 mgd. This would be sufficient to handle the anticipated 1.3 mgd average dry weather flows. The revised permit specifies updated waste discharge requirements ("WDRs") based on the updated wastewater treatment technology that would be installed on site, as discussed previously in Chapter II, Project Description. The updated WDRs would be achievable based on the proposed technology grades, would meet current RWQCB standards, and would likely exceed the standards that were imposed under existing conditions.

The basic purposes of primary and secondary treatment include removing inorganic and organic solids, thereby meeting the NPDES permit's effluent limitations for Total Dissolved Solids and Biochemical Oxygen Demand ("BOD₅"). Under primary treatment, a headworks removes floating solids, grit, and floating oil and grease. A primary sedimentation tank removes settleable solids. This technology has been used successfully for decades. However, to remove suspended solids, including organic solids that would otherwise decompose, and dissolved oxygen from the receiving water, secondary treatment would be used. (It is important to limit the uptake of dissolved oxygen from the receiving water, because fish and other living things in the receiving water depend on dissolved oxygen.) The proposed secondary treatment includes Trickling Filter / Solids Contact ("TF/SC"). TF/SC has been successfully used in the United States since 1979, and advancements over the years have improved its effectiveness.⁷³ TF/SC can typically achieve less than 20 mg/L BOD₅.⁷⁴ The NPDES limit is 30 mg/L BOD₅ monthly average and 45 mg/L BOD₅ weekly average; therefore, the TF/SC technology would meet these limits. The closest TF/SC plants to the Proposed Project are located in Hayward and Vallejo, and both are considerably larger than the existing and proposed plants at Treasure Island. Regarding other

⁷³ Parker, D.S., P.E. Member, and J.R. Bratby, "Review of Two Decades of Experience with TF/SC Process," *Journal of Environmental Engineering*, Vol. 127, No. 5, May 2001, pp. 380-387.

⁷⁴ Water Environment Federation and the American Society of Civil Engineers, Environmental and Water Resources Institute, *Water Environment Federation Manual of Practice for the Design of Municipal Wastewater Treatment Plants*, Chapter 15, Integrated Biological Treatment (2010), p. 15-15.

NPDES permit limits, coliform bacteria would be killed using ultraviolet light, a disinfection method that reduces the use of potentially toxic chemicals. Effluent pH (how acidic or how caustic the effluent is) would be addressed through common methods of adding chemicals. In sum, the treatment processes have been well tested in many other locations and are expected to meet the NPDES permit limitations. Therefore, it is expected that no water quality degradation associated with operation of the proposed treatment plant would occur, and impacts would be less than significant. No mitigation is required.

Use of Recycled Water for Irrigation and Firefighting

Approximately 200 acres of land area on Treasure Island proposed as open space would require temporary or permanent irrigation to establish and/or maintain vegetation. Irrigation would occur primarily during the dry season, from April through October, using recycled water, at a rate of approximately 0.3 to 0.41 mgd, from a proposed water recycling facility associated with the proposed treatment plant upgrade. Recycled water would be treated to meet RWQCB recycled water standards. Recycled water usage would be required to comply with relevant State and local requirements for type of use and discharge requirements under Title 22 of the California Code of Regulations and the NPDES General Permit for Landscape Irrigation Uses of Recycled Water, as described in “Regulatory Framework,” p. IV.O.16. Because recycled water would be treated to current standards for recycled water quality, no significant degradation of surface or groundwater quality is anticipated to result from irrigation using recycled water. Additionally, recycled water would be used to provide supplemental supply for firefighting under some circumstances on Treasure Island. Recycled water used for firefighting would be treated to applicable State standards for the proposed use, and would therefore not result in significant degradation of water quality. This impact would be less than significant, and no mitigation is required.

Urban Runoff

During operation, the Proposed Project would result in the generation of potential water pollution associated with urban and landscaped uses. Specifically, fuel, oil, brake dust, coolant, and other pollutants derived from automotive uses, as well as trash, dust/soil, sediment, fertilizer, pesticides, and animal wastes derived from landscaping activities and human activity, could become entrained in stormwater or other surface water flows, and eventually be released into groundwater or San Francisco Bay. The Proposed Project would include installation of a stormwater treatment system (see Section IV.K, Utilities and Service Systems, p. IV.K.28). This system would be designed to treat stormwater to the maximum extent practicable in accordance with RWQCB standards and, where applicable, the SFPUC Stormwater Design Guidelines. Compliance would include preparation and implementation of a Stormwater Control Plan for the Proposed Project, as discussed below.

A stormwater wetland would be constructed to treat a substantial portion of the runoff on Treasure Island (see pp. IV.K.32-IV.K.33). In addition, the Proposed Project would include preparing and implementing a Stormwater Control Plan that would describe operations and maintenance of structural BMPs as well as required pollutant source controls such as street

- sweeping, fertilizer and pesticide controls, and animal waste reduction. Typical BMPs to treat urban runoff can include, but are not limited to, the following: (1) use of grassy swales, vegetated strips, and other biofilters to remove sediment and other contaminants from stormwater prior to its conveyance in stormwater facilities; (2) installation and maintenance of trash screens on all storm system inflows, and/or at key points along the stormwater system, to provide effective trash removal; (3) use of pervious pavement or other pervious surfaces for parking lot surfaces, to reduce runoff volumes and encourage infiltration; and (4) use of sedimentation ponds, holding basins, ground stabilization measures, and other structural features as needed to reduce entrained sediment and contaminants removal prior to stormwater discharge.

- With implementation of the proposed stormwater treatment system and adherence to the proposed Stormwater Control Plan (as developed pursuant to the Stormwater Management Ordinance and Stormwater Design Guidelines), urban runoff from the Proposed Project would not result in water quality degradation. Under existing conditions, much of Treasure Island is covered by impervious surfaces, and stormwater is discharged to the Bay without treatment. The Proposed Project would reduce impervious surfaces on the island and would treat stormwater prior to discharge. Therefore, these potential impacts on water quality associated with operation of the Proposed Project would be considered less than significant. No mitigation is required.

Methylmercury Generation

Methylmercury generation is discussed in Section IV.M, Biological Resources. Please refer to that section for a discussion of the potential effects on water quality that are relevant to biological resources.

Impact HY-9: The Proposed Project would not result in depletion of groundwater or reduction of groundwater levels during operation. (*Less than Significant*)

Implementation of the Proposed Project would not include installation of groundwater wells or other groundwater extraction facilities located within the Project Area. Instead, the Proposed Project would receive its water from the SFPUC. As discussed in Section IV.K, Utilities and Service Systems, in “K.4 “Water Supply and Distribution System,” p. IV.K.38, SFPUC collects less than 4 percent of its total water supply from groundwater. Therefore, the water provided to the Proposed Project would include only a small fraction of groundwater, which on average would be less than 4 percent of the total water supplied to the Proposed Project. This amount of potential additional groundwater withdrawals (less than

0.053 mgd) by the SFPUC through their system would be anticipated to have only a minor and insignificant effect on groundwater levels.

Groundwater levels can also be affected by changes to existing infiltration rates, as a result of the installation of impervious surfaces. Specifically, installation of hardscape surfaces that do not allow water to infiltrate to groundwater can reduce groundwater recharge rates, resulting in a lowering of the local groundwater table. Within the Development Plan Area, intensification of existing use within the southeastern and southwestern sides, and the central portion of Treasure Island, and in isolated portions of Yerba Buena Island, would result in the construction of impervious surfaces. However, for Treasure Island, the proposed impervious surfaces would be installed primarily into areas of existing impervious surfaces. Additionally, substantial areas of Treasure Island that are currently covered by impervious surfaces would be restored to pervious, open space areas, such that an approximately 25 percent net reduction in impervious surfaces would occur, as compared to current conditions. For Yerba Buena Island, proposed development would occur approximately within the footprint for existing development, and therefore is not anticipated to substantially alter existing groundwater recharge conditions. Therefore, groundwater levels within the Development Plan Area would not be anticipated to be significantly affected by implementation of the Proposed Project. Additionally, groundwater is not currently used and is not proposed to be used as a source of residential or municipal water supply. Therefore, no residential or municipal supply wells would be affected. This impact would be less than significant, and no mitigation measures is required.

Impact HY-10: The Proposed Project would not create impervious surfaces that would collect pollutants that could cause water quality impacts from rainwater runoff. (*Less than Significant*)

The Proposed Project would result in a net removal of approximately 25 percent of existing impervious surfaces on Treasure Island, and a slight increase in impervious surfaces on Yerba Buena Island. Impervious surfaces increase runoff rates and prevent the infiltration of stormwater to the subsurface (see Impact HY-9, above). Impervious surfaces also collect vehicle and pedestrian-related pollutants, including greases, oils, brake dust, food wastes, trash, and soil/sediment. During storm events, these and other pollutants can become entrained in stormwater, run off the site where they originate, and degrade the water quality in receiving water bodies. However, the Proposed Project would include measures to minimize the installation of new impervious surfaces to the maximum extent practicable, and it is anticipated that by implementing the measures contained in the Proposed Project, no net increase in impervious surface area would occur overall. The Proposed Project would include installation of a stormwater treatment system (see Section IV.K, Utilities and Service Systems, p. IV.K.28). This system would be designed to treat stormwater to the maximum extent practicable in accordance with RWQCB standards, and, where applicable, the SFPUC Stormwater Design Guidelines.

- With the proposed stormwater treatment system and the proposed Stormwater Control Plan, these impacts would be less than significant. No mitigation measures are required.

Impact HY-11: The Proposed Project would not be susceptible to inundation by seiche, tsunami, mudflow, or wind waves. (*Less than Significant*)

The Project Area is comprised of two small islands. Treasure Island has a flat topography, and Yerba Buena Island is a rocky outcropping of bedrock with relatively shallow unconsolidated soils, and steep terrain. Potential for mudflows would be expected where larger, steep catchments intersect with deep unconsolidated soils, especially in areas where mass denuding of vegetation would occur. These conditions are not present for the Proposed Project. Therefore, the Development Plan Area would not be susceptible to mudflow. Portions of the Development Plan Area would, however, be susceptible to seiche within San Francisco Bay, and to tsunami originating in the Pacific Ocean. A tsunami is anticipated to raise water levels in the vicinity of the Proposed Project. As discussed in “Flooding, Waves, Tsunami, and Seiche,” p. IV.O.5, geologic-induced seiche has not been documented in San Francisco Bay.

The 100-year return period water level resulting from a combination of astronomical tides, surge, waves, and tsunami was estimated to be 9.2 feet, NAVD88.⁷⁵ Maximum run-up conditions for combined astronomical tides, surge, waves, and tsunami would be 10.0 to 16.3 feet NAVD88, as discussed previously. Because the Proposed Project includes strengthening and raising the protective berms around the perimeter of Treasure Island as needed to prevent inundation under maximum run-up conditions for combined astronomical tides, surge, waves, and tsunami, the potential for flooding from these sources would be less than significant, and no mitigation would be required. For a discussion of potential effects of climate-induced sea level rise on the Proposed Project, see Impact HY-12.

Impact HY-12: The Proposed Project would not expose people or structures to increased risk of flooding due to climate-induced sea level rise. (*Less than Significant*)

The Proposed Project could be subject to future potential sea level rise. As discussed in “Future Potential Climate-Induced Sea Level Rise,” pp. IV.O.30 - IV.O.32, Moffatt and Nichol⁷⁶ completed a literature review of widely published and scientifically credible literature regarding future potential sea level rise, indicating that credible projections for future potential sea level rise vary substantially. Low, medium, and high rates of potential sea level rise were identified, ranging from 3 inches by 2050 and 12 inches by 2100, to 16 inches by 2050 and 55 inches by 2100. Because the Proposed Project encompasses many low-lying areas, in particular all of Treasure Island and some low-lying areas along the western flank of Yerba Buena Island near the existing U.S. Coast Guard Station and Sector Facility, a substantial portion of the Redevelopment Plan Project Area, at current elevations and without future improvements, could potentially be at risk of inundation due to future potential sea level rise.

⁷⁵ Coastal Flooding Study 2009.

⁷⁶ Coastal Flooding Study 2009.

The estimates of future potential sea level rise considered in the Coastal Flooding Report⁷⁷ account for potential sea level rise combined with other coincident conditions, including the influence of tides, storm events, storm surge, waves, and tsunamis. For instance, if no action were taken, under a 55-inch sea level rise scenario, shorefront areas along the existing Treasure Island perimeter would be inundated during a mean higher high water (“MHHW”) tidal event, and areas surrounding the U.S. Coast Guard Station and Sector Facility on Yerba Buena Island could also become inundated.

Because the rate of future potential sea level rise is impossible to accurately predict, and because current estimates indicate a high degree of potential variability and uncertainty in both amount and timing, several elements have been included in the Proposed Project to mitigate the potential effects of sea level rise. As reviewed in detail in “Elements Included in the Proposed Project to Accommodate the Potential for Sea Level Rise,” p. IV.O.32, major proposed elements include the following: (1) improvements proposed during the initial infrastructure construction and site preparation in Phase 1; (2) implementation of a long-term adaptive management strategy, including future improvements as needed to accommodate actual sea level rise as it develops; and (3) periodic status reporting on the Proposed Project’s adaptive management strategy.

Together, these elements would result in a series of improvements that would counter the effects of future potential sea level rise. For instance, raising the perimeter berm where necessary would prevent significant wave overtopping onto perimeter open space during storm events, for up to 16 inches of future sea level rise. All new building pads, streets, and vital infrastructure in new development areas would be raised to be between 36 and 42 inches above the current 100-year high tide elevation, accommodating up to 36 inches of sea level rise as compared to present-day conditions. Storm drain system designs would accommodate up to 16 inches of sea level rise, as well as provisions for pump stations to be installed in the future if future potential sea level rise exceeds 16 inches, or pump stations are otherwise warranted. Finally, after completion of initial improvements, TIDA would oversee the management and implementation of an adaptive management program for future potential sea level rise. The adaptive management program would include, but not be limited to, implementation of an ongoing sea level rise data review and monitoring program; a decision-making framework for future improvements to protect the island from potential flooding due to sea level rise; and a mechanism for collecting and administering funds to pay for the cost of the adaptive management program.

The adaptive management program would include identified thresholds for action, depending on the intensity of future potential sea level rise, as the effects of sea level rise are realized. For instance, for future potential sea level rise between 16 and 36 inches, storm drain stations would be constructed at storm drain outfalls with pump stations as needed; installation of additional storm pumps would be implemented as needed; changes to the shape of the perimeter berm would be initiated, as needed to reduce wave run-up and overtopping; the perimeter of Treasure Island

⁷⁷ Coastal Flooding Study 2009.

could be raised to serve as a storm surge barrier or levee; a series of embankments to increase heights inland from the shoreline could be installed, as needed, and/or sea walls could be constructed, in particular at the ferry quay and along Clipper Cove. For sea level rise beyond 36 inches, additional actions would be implemented, as described on pp. IV.O.34.

Implementation of these elements of the Proposed Project would ensure that future potential sea level rise is accounted for and accommodated, in order to minimize inundation of the Development Plan Area. The measures and adaptive management strategy included in the Proposed Project would account for the effects of future potential sea level rise, combined with storm and wave run-up events. Therefore, future potential sea level rise would result in a less-than-significant impact on the Proposed Project. No additional mitigation is required.

CUMULATIVE IMPACTS

Impact HY-13: The Project would not result in cumulative impacts related to hydrology and water quality. (*Not Cumulatively Considerable*)

As discussed above, implementation of the Proposed Project would include design measures that would reduce direct hydrology and water quality impacts to less-than-significant levels. Specifically, potential changes related to stormwater quality, stormwater flows, impervious surfaces, and flooding would be minimized via the implementation of stormwater control measures, stormwater retention measures, stormwater quality control measures, and structural updates to the Proposed Project to minimize flooding.

Cumulative impacts can result from individually minor but collectively significant projects taking place over a period of time. Cumulative projects that could combine with the less-than-significant incremental impacts of the Proposed Project to compound or increase any existing hydrology- or water-quality-related cumulative impacts include, for example, potential cumulative reductions in the water quality of San Francisco Bay, or degradation of urban stormwater quality. Nearby and similar projects, such as the proposed expansion of the Clipper Cove Marina, would require dredging and other work in the Bay. However, similar permit requirements would apply, and the potential direct impacts of the Proposed Project, discussed previously in this section regarding hydrology and water quality would not be substantial, and would not substantially contribute to any cumulative impacts. The Yerba Buena Island Ramps Improvement Project on Yerba Buena Island could result in sediment or other contaminants in the Bay during construction; however, construction permits would require controls similar to those described for the Proposed Project that would reduce impacts to less-than-significant levels, and no significant cumulative impacts would result. Therefore, the incremental impacts on hydrology and water quality of this Proposed Project are not cumulatively considerable when viewed in connection with the effects of the other past, present, and reasonably foreseeable probable future projects in the vicinity of the site.

REFERENCES–HYDROLOGY AND WATER QUALITY

Mount, J. 2007. Sea Level Rise and Delta Planning. Letter from Jeffrey Mount, Chair, CalFED Independent Science Board to Michael Healey, Lead Scientist, CALFED Bay-Delta Program, September 6, 2007.

San Francisco Public Utilities Commission (SFPUC), 2005. 2005 Urban Water Management Plan for the City and County of San Francisco. December, 2005.

P. HAZARDS AND HAZARDOUS MATERIALS

This section discusses the hazardous materials issues associated with the Project Area and Proposed Project construction and operations. The hazardous materials issues evaluated include past chemical use and potential presence of associated toxic substances in soil and groundwater at the site; past on-site and off-site storage and release of petroleum products, including the presence and former presence of underground storage tanks at the site; potential hazardous waste issues during construction of the Proposed Project; and the potential for activities related to the Proposed Project to generate hazardous materials and/or hazardous wastes. This section identifies potential impacts and appropriate mitigation measures, when necessary.

This section also describes the regulatory process for remediation of the site that is currently under the responsibility of the U.S. Navy (“Navy”). These activities are ongoing and will occur with or without the Proposed Project. These activities are a precursor to future transfer and redevelopment of the area, either as the Proposed Project or for some other use. Information regarding remediation is provided for informational purposes.

GENERAL BACKGROUND

HAZARDOUS MATERIALS BASIC CONCEPTS AND TERMS

Under Federal and State laws, “discarded materials” and other “wastes” may be considered “hazardous waste” if they are specifically listed by statute as such or if they are poisonous (toxicity), can be ignited by open flame (ignitability), corrode other materials (corrosivity), or react violently, explode or generate vapors when mixed with water (reactivity). The term “hazardous material” is defined in State law as any material that, because of quantity, concentration, or physical or chemical characteristics, poses a significant present or potential hazard to human health and safety or to the environment.¹ A hazardous material can include a hazardous substance, hazardous waste, or any other materials where a potential risk to human health or the environment has been identified.

At many locations not specific to Naval Station Treasure Island (“NSTI”), past industrial or commercial activities on a site could have resulted in spills or leaks of hazardous materials to the ground, resulting in soil and/or groundwater contamination. The presence of certain hazardous materials can also lead to the buildup of methane gas, which if trapped under or within structures can become an explosive hazard. Federal and State laws require that hazardous materials be specially managed and that excavated soils having concentrations of contaminants such as lead, gasoline, or industrial solvents that are higher than certain acceptable levels, be specially

¹ State of California, Health and Safety Code, Chapter 6.95, Section 25501(o).

managed, treated, transported, and/or disposed of as a hazardous waste. The California Code of Regulations, Title 22, Sections 66261.20–24 contains technical descriptions of characteristics that would cause a soil, once excavated and discarded, to be designated a hazardous waste. The California regulations are compliant with Federal regulations and, in most cases, are more stringent.

HAZARDOUS BUILDING MATERIALS

The Development Plan Area has had various periods of development over its history and many of the existing structures were built decades ago. Like many older buildings, these structures may contain building materials that can be hazardous to people and the environment once disturbed. Typical hazardous materials in buildings of this age include lead-based paint, asbestos, and polychlorinated biphenyls (“PCBs”).

Prior to the U.S. Environmental Protection Agency (“EPA”) ban in 1978, lead-based paint was commonly used on interior and exterior building surfaces. Through such disturbances as sanding and scraping activities, renovation work, or gradual wear and tear, old peeling paint or paint dust particulates have been found to contaminate surface soils or cause lead dust to migrate and affect long-term indoor air quality. Exposure to lead can cause severe adverse health effects, especially in children.

Asbestos is a naturally occurring fibrous material that was extensively used as a fireproofing and insulating agent in building construction materials before such uses were banned by the EPA in the 1970s. Asbestos was commonly used for insulation of heating ducts as well as ceiling and floor tiles, to name a few typical types of materials. While contained within building materials, asbestos fibers present no significant health risk, but once these tiny fibers (that cannot be seen with the naked eye) are disturbed, they can become airborne. Once they are inhaled they can become lodged in the lungs, potentially causing increased incidence of lung disease or other pulmonary complications.

PCBs are petroleum-based oils that were formerly used primarily as insulators in many types of electrical equipment including transformers and capacitors. After PCBs were determined to be carcinogenic in the mid to late 1970s, EPA banned PCB use in most new equipment and began a program to phase out certain existing PCB-containing equipment. Fluorescent lighting ballasts manufactured after January 1, 1978 do not contain PCBs and are required to have a label clearly stating that PCBs are not present in the unit. Additional information about these materials is provided in “Regulatory Framework,” p. IV.P.32.

BACKGROUND ON BASE CLOSURE REMEDIATION REQUIREMENTS

The Navy intends to transfer NSTI to the Treasure Island Development Authority (“TIDA”), which is the designated Local Redevelopment Authority. Since NSTI was closed in 1997, TIDA and the Navy have been in discussions regarding the conveyance of the former military base. Over the past decade and a half, the Navy has undertaken a thorough and lengthy process to identify, analyze, and clean up any releases of hazardous materials and wastes associated with their past operations. The process is being undertaken according to a well-developed procedural manual known as the *Base Redevelopment and Realignment Manual*, prepared by the U.S. Department of Defense (“DoD”). The following Setting section and subsequent analysis considers these activities as part of the existing conditions of the Project Area; the Navy’s remediation activities are not part of the Proposed Project. The information contained in this section represents the most recent information available at the time of preparation of this document, but the Navy’s investigation and cleanup activities are ongoing and continually changing.²

INSTALLATION RESTORATION PROGRAM

The Installation Restoration (“IR”) Program is a DoD initiative to identify, investigate, and clean up hazardous waste sites located on former military bases. The DoD established the IR Program in 1975. Depending upon the circumstances, IR sites are identified, investigated, and cleaned up in accordance with the Resource Conservation and Recovery Act (“RCRA”), the Comprehensive Environmental Response, Compensation, and Liability Act (“CERCLA”) or in accordance with an integrated approach based on both laws. In addition, for sites that are associated primarily with petroleum contamination, the IR Program is conducted according to what is known as the Petroleum Program (discussed further in “Regulatory Framework,” p. IV.P.29). RCRA was enacted in 1976, and is the principal Federal law in the United States governing the disposal of solid and hazardous waste. For NSTI, the IR Program implemented at the former base consists of the CERCLA and Petroleum Programs.³

SITE EVALUATION, REMEDIATION, AND CLOSURE PROCEDURES

Site closure is generally determined based on an evaluation of the overall assessment of the site characterization of contaminants of potential concern (“COPCs”) and evaluation of potential risk to human health and the environment. To evaluate these potential risks, screening levels are

² The most recent information concerning the investigations and cleanup were obtained from the 2010 Draft Site Management Plan prepared by environmental consultant Tetra Tech. A copy of this report is available for public review at the San Francisco Planning Department, 1650 Mission Street, Suite 400, in Case File No. 2007.0903E.

³ In general, the CERCLA sites at NSTI are overseen by the Department of Toxic Substances Control and the Petroleum Program sites are overseen by the Regional Water Quality Control Board. The responsibilities of these agencies are discussed further in the Regulatory Framework section below.

published by State and Federal agencies, including the California Department of Toxic Substances Control (“DTSC”) (the DTSC screening levels are identified as CHHSLs),⁴ the San Francisco Regional Water Quality Control Board (“RWQCB”) (ESLs),⁵ and the EPA (PRGs).⁶ It is generally accepted that detections of chemicals at concentrations below their applicable screening levels mean that the chemicals pose no significant, long-term threat to human health or the environment.⁷ Thus, these screening levels are often used to evaluate the potential for risk at a site associated with the presence of COPCs in soil and/or groundwater. Such screening levels do not, however, constitute regulatory cleanup standards.

The presence of contaminants at concentrations in excess of their designated screening levels does not necessarily indicate that adverse impacts to human health or the environment are occurring; it simply indicates that potential risks may exist and that additional site-specific evaluation is warranted. Generally, when screening levels are exceeded, a Risk Assessment is performed using site specific exposure scenarios to evaluate whether adverse impacts to human health or the environment could occur. Established risk assessment procedures use numerical risk values that are estimated for both carcinogenic and non-carcinogenic compounds. Often the threshold of concern is based on a one-in-a-million (1×10^{-6}) cancer risk for a given land use. However, the EPA risk management range is one-in-ten-thousand (1×10^{-4}) to 1×10^{-6} , and a variety of thresholds within this range have been used at NSTI.⁸ Toxic or other harmful properties of a contaminant can vary greatly from one contaminant to the next, and from individual to individual. Whether the contaminant results in health effects to an individual varies greatly and depends on such factors as the amount (dose), characteristics of the individual (e.g., age, gender, height/weight, general health), length of time the individual is exposed, and how the contaminant enters the body (exposure pathway).

⁴ CHHSLs – California Human Health Screening Levels are concentrations of 54 hazardous chemicals in soil or soil gas that the DTSC considers to be thresholds of concern for risks to human health. The DTSC routinely use the CHHSLs to guide their directives for site investigation and remediation but they are based on standard exposure assumptions and do not account for site specific characteristics.

⁵ ESLs – Environmental Screening Levels are routinely used by the RWQCB to guide decisions regarding investigations and remedial activities for contamination sites. ESLs are based on conservative, generic risk coefficients for exposure of hazardous materials.

⁶ PRGs – Preliminary Remediation Goals developed by the US EPA to address human health concerns regarding direct exposure with contaminated soils. PRGs are generally consistent with human health risk assessment guidance prepared by the DTSC.

⁷ The soil screening levels at Treasure Island also consider the existing ambient or background concentrations for metals.

⁸ Cancer risks that fall in between this risk management range, such as a one-in-one-hundred-thousand (1×10^{-5}) chance of causing cancer, would then be evaluated by the overseeing agency, such as DTSC, to determine whether it is acceptable on a case-by-case basis. The factors involved in the determination include the particular contaminant(s) causing the cancer risk, proposed land uses, subsurface materials, potential exposure pathways, and other site-specific data. For cases where calculated risks are greater than one-in-ten-thousand (1×10^{-4}), such as one-in-a-thousand (1×10^{-3}), additional cleanup activities would be required.

IV. Environmental Setting and Impacts

The following represents the general steps necessary for site closure according to established BRAC procedures and CERCLA requirements. Some IR sites have already completed some of

the steps listed below, and not all IR sites would require completion of each step listed.

Petroleum sites follow the closure procedure established by the RWQCB and may not be subject to all of the processes listed.

- Conduct Preliminary Assessments and Site Inspections to determine site conditions. For the Naval Station Treasure Island, these preliminary assessments have all been completed.
- Prepare a Remedial Investigation (“RI”) work plan, including a Sampling and Analysis Plan, Health and Safety Plan, and a Quality Assurance Project Plan to address existing data gaps. Data gaps can include evaluating areas where the vertical or horizontal extent of contamination is not known or to include CPOCs not evaluated in previous investigations.
- Perform soil and groundwater sampling analysis according to the plans stated above.
- Prepare an RI that includes findings of each phase of investigation and a Human Health Risk Assessment and Ecological Risk Assessment, if applicable. The Human Health Risk Assessment and Ecological Risk Assessment determines human health-based and ecological-based remediation goals for a site based on calculated risk management factors according to established risk assessment protocols.
- Conduct a Feasibility Study (“FS”) in accordance with CERCLA or Petroleum Program requirements. The Feasibility Study evaluates the COPCs and the available remediation technologies to reduce the levels of COPCs to levels that have acceptable levels of risk. The levels of risk, or health-based risks, that are deemed acceptable are generally based on statistical calculations of cancer risk (i.e., one-in-a-million cancer risk) considering the site specific conditions and potential pathways of exposure. For example, contamination that is found at depths beneath relatively impenetrable materials like concrete or very tight clays represents a much lower risk than shallow contamination of relatively porous soils in open landscaped areas.
- Prepare a Record of Decision (“ROD”) in accordance with CERCLA or Petroleum Program requirements. The ROD includes a description of the preferred remedial alternative for cleanup and closure of the site in accordance with CERCLA or Petroleum Program requirements.
- Prepare and implement a Remedial Design/Remedial Action Work Plan in accordance with CERCLA or Petroleum Program requirements. The Remedial Design/Remedial Action Plan provides the means by which the site will achieve its remediation goals through a reduction of existing contamination levels or other engineering, institutional controls, or through containment of existing contaminants.
- For sites where excavation, removal of contaminated soils, and offsite disposal of soils is recommended, the Navy will prepare and implement an excavation work plan (including a Sampling and Analysis Plan, Health and Safety Plan, and a Quality Assurance Project Plan).
- Operate, monitor and maintain remediation programs until remediation goals are achieved and/or regulatory closure is obtained.
- Prepare a Remediation Action Completion Report documenting successful completion of remedial activities in accordance with CERCLA or Petroleum Program requirements.

PROPERTY TRANSFER

The most common method for the Navy to support transfer of a closed base such as NSTI is to first obtain site closure for individual parcels, as described above. The Navy will then prepare what is known as a Finding of Suitability to Transfer (“FOST”) for each parcel it plans to transfer.

The primary purpose of a FOST is to document that the property is environmentally suitable for transfer by deed under DoD FOST guidance. This process is intended to determine whether property is environmentally suitable for its intended use and whether there should be any restricted use of the property (i.e., institutional controls such as limits on land use or notification requirements prior to any subsurface disturbances). Institutional controls are structural or legal mechanisms used to limit access to, or restrict the use of property. A FOST must demonstrate that either the property is uncontaminated or that all necessary remediation has been completed or is in place and operating properly and successfully. These demonstrations are necessary to support the deed covenant required by the Comprehensive Environmental Response, Compensation, and Liability Act (“CERCLA”) that all remedial action necessary to protect human health and the environment has been taken. In addition, under CERCLA, a deed to transfer property by the United States must contain (1) notice of the type and quantity of hazardous substances, (2) notice of the time at which such hazardous substance storage, release, or disposal took place, and (3) a description of any remedial action taken.

The Navy has already issued a FOST for a 170-acre portion of NSTI and will continue to issue FOSTs over several large phases in the upcoming years. The Navy is not required, however, to obtain site closure prior to transferring a parcel. Instead, the Navy can prepare a Finding of Suitability for Early Transfer (“FOSET”) and transfer a parcel via an Early Transfer. The primary purpose of a FOSET is to document that the property is environmentally suitable for transfer under the provisions in CERCLA that allow the Governor to approve an “early transfer” and “defer” (until completion of the cleanup after transfer) the issuance of the covenant, otherwise required in the deed by CERCLA, that all necessary remediation has been completed or is in place and operating properly and successfully. Before the Governor can approve a proposed covenant deferral allowing early transfer, he or she must make certain legal findings designed to ensure that the transfer of contaminated federal property will not endanger human health or the environment, and that early transfer will not delay the cleanup of the base. The FOSET contains the information about the condition of the property and status of cleanup activities necessary to support such findings, analyzes the intended land use during the period before remediation will be complete, and makes a determination of what interim use restrictions will need to be imposed in the deed or a separate land use covenant to ensure the contamination will not endanger human health or the environment and that the cleanup will not be delayed.

Early transfers are often coupled with transfers of cleanup responsibility from the military to the local agency and project applicants. Such transfers are accomplished through an agreement between the military and the local agency specifying which aspects of the cleanup will be transferred to the local agency and which will be retained by the military (e.g., responsibility for any radioactive contamination). The local agency and project applicant often then execute a similar agreement to pass through the cleanup obligations to the project applicant. In addition, the local agency and/or project applicant enter into a legally enforceable consent agreement with the state regulatory agency overseeing the cleanup, requiring them to perform the cleanup obligations being transferred from the military.

Base parcels where remediation has not been completed may also be leased to the local agency and subleased to the project applicant through a short-term lease (which can be as long as 10 years) or a Lease in Furtherance of Conveyance (“LIFOC”), which can be for as long as 60 years and has many of the attributes of ownership. A LIFOC can only be executed with a local agency (like TIDA), which has an agreement with the military to ultimately transfer ownership of the property. For either type of lease, a document called a Finding of Suitability to Lease (“FOSL”) is prepared by the military and approved by the environmental regulatory agencies. A FOSL is similar to a FOSET, describing the condition of the property and status of cleanup activities and analyzing the intended land use and activities during the lease term to determine what restrictions would need to be added as conditions of the lease or LIFOC to ensure the contamination will not endanger human health or the environment and that there will not be interference with the remediation activities.

SETTING

GEOLOGY AND GROUNDWATER

Treasure Island was originally constructed on a sand spit known as Yerba Buena Shoals that extended off the northwestern point of Yerba Buena Island. In preparation for the 1939 Exposition, the island was created by importing dredged sands from various sources within San Francisco Bay. The fill sands were contained by a series of rock dikes constructed around the perimeter of the island. The sands are underlain by the soft compressible clay layer known as Young Bay Mud. The Young Bay Mud is underlain in areas by a series of dense sands and clays known as Merritt-Posey-San Antonio (“MPSA”).⁹ Beneath the MPSA layer are older bay clays known as Old Bay Mud or Old Bay Clay.¹⁰

⁹ Engeo Incorporated, *Geotechnical Conceptual Design Report, Treasure Island, San Francisco*, February 2, 2009 (hereinafter “Engeo TI, 2009”). A copy of this document is available for public review at the San Francisco Planning Department, 1650 Mission Street, Suite 400, in Case File No. 2007.0903E.

¹⁰ Engeo TI, 2009.

Yerba Buena Island is primarily underlain by sedimentary rocks of the Franciscan Complex in addition to dune sand, alluvium and artificial fill materials.¹¹ Over the years, upland fills at Yerba Buena Island were created using onsite sources and bay margin fills from dredge materials.¹² (More detail on the geology of the Islands is presented in Section IV.N, Geology and Soils.)

Groundwater on Treasure Island is generally encountered at an elevation of approximately 3 to 9 feet above mean lower low water level (“MLLW”).¹³ Assuming a general elevation of 13 feet, groundwater is encountered at a depth ranging from 4 to 10 feet below ground surface. In general, groundwater is encountered at a shallower depth toward the center of the island. Groundwater has generally not been encountered at shallow depths in the upper regions of Yerba Buena Island. Along Macalla Road, groundwater was encountered at approximately 60 to 90 feet below ground surface.¹⁴ For the eastern approaches to the Yerba Buena Island tunnel, groundwater was encountered at depths ranging from 20 feet below ground surface to close to sea level. (See also Section IV.O, Hydrology and Water Quality, for more discussion regarding groundwater.)

Treasure Island is relatively flat with little topographic relief. Surface elevations at Treasure Island range from approximately 6 to 14 feet MLLW. Yerba Buena Island rises to a maximum elevation of approximately 350 feet with steep slopes along the perimeter.

REDEVELOPMENT PLAN PROJECT AREA – HISTORICAL AND CURRENT USE

Military activities at Yerba Buena Island date back to 1896 with uses by the U.S. Army and Navy. In 1941, following the 1939 International Exposition, the Navy, already present on Yerba Buena Island, acquired Treasure Island and portions of Yerba Buena Island, and converted these areas into the NSTI, which served largely as an electronics and radio communications training school and as a major naval departure point. Navy activities included training facilities, administrative offices, general engineering support, mission operations, personnel support, medical and dental services, maintenance activities, utility infrastructure, and supply operations.

NSTI was selected for closure under the Base Closure and Realignment (“BRAC”) program in 1993, and was subsequently decommissioned in 1997 following a base wide environmental

¹¹ Engeo, Incorporated, *Geotechnical Conceptual Design Report, Yerba Buena Island, San Francisco*, November 21, 2008 (hereinafter “Engeo YBI, 2008”). A copy of this document is available for public review at the San Francisco Planning Department, 1650 Mission Street, Suite 400, in Case File No. 2007.0903E.

¹² Engeo YBI, 2008.

¹³ MLLW elevations are approximately 0.1 feet higher than the North American Vertical Datum (“NAVD”) from 1988 which is often used to describe the elevations at Treasure Island. Engeo TI, 2009.

¹⁴ Engeo YBI, 2008.

baseline survey (“EBS”) completed in 1994, which was required as part of the BRAC program.¹⁵ The EBS is a broad evaluation of all known and suspected hazardous materials that were handled, stored, or potentially released into the environment from base operations. The results of the EBS confirmed that portions of the Development Plan Area contain soil and groundwater that have been impacted by hazardous materials.

Current uses on the Islands include a variety of activities such as film and TV production, an elementary school (being used for other educational activities), a daycare center, approximately 805 occupiable housing units, a sailing school, and various playing fields.

CURRENT CONDITIONS

Overview

The Navy conducted its EBS for NSTI in 1994 (which was later updated with a supplemental EBS in 2005). The results of the EBS confirmed that portions of the Project Area contain soil and groundwater that have been affected by hazardous materials. The Navy has continued to do investigative work since the EBS, which has identified additional hazardous

- materials. All investigation and cleanup requirements for the sites are overseen by the EPA, DTSC, and/or the RWQCB. Through its work, the Navy has identified the chemicals of potential concern (“COPCs”) for NSTI, which include petroleum hydrocarbons, volatile organic compounds (“VOCs”), semi-volatile organic compounds (“SVOCs”), poly-aromatic hydrocarbons (“PAHs”), dioxins, pesticides, herbicides, PCBs, heavy metals (primarily lead), asbestos, and low-level radiological material. Remediation of the identified contamination is administered under the IR Program. Contaminants become a potential concern if they have been identified as carcinogens or if at certain concentrations their toxicity has been found to have an adverse effect on human health or the environment. Some chemicals break down quickly in the environment; however, some may persist over years or even decades and accumulate over time to levels that may be harmful to the environment and organisms. Different contaminants have different toxic potencies and can have an impact upon different biological functions or parts of the environment.

During the course of an investigation for soil and groundwater contamination, initial results are typically compared to regulatory screening levels or site specific action levels which help evaluate subsequent courses of action. However, final cleanup requirements are typically set on a site-by-site basis based on site specific exposure scenario analyses for human health and the environment. The site locations are shown on Figure IV.P.1: Installation Restoration Site Inventory.

¹⁵ Some environmental investigations and cleanup activities at NSTI began in the mid-1980s prior to consideration for closure.

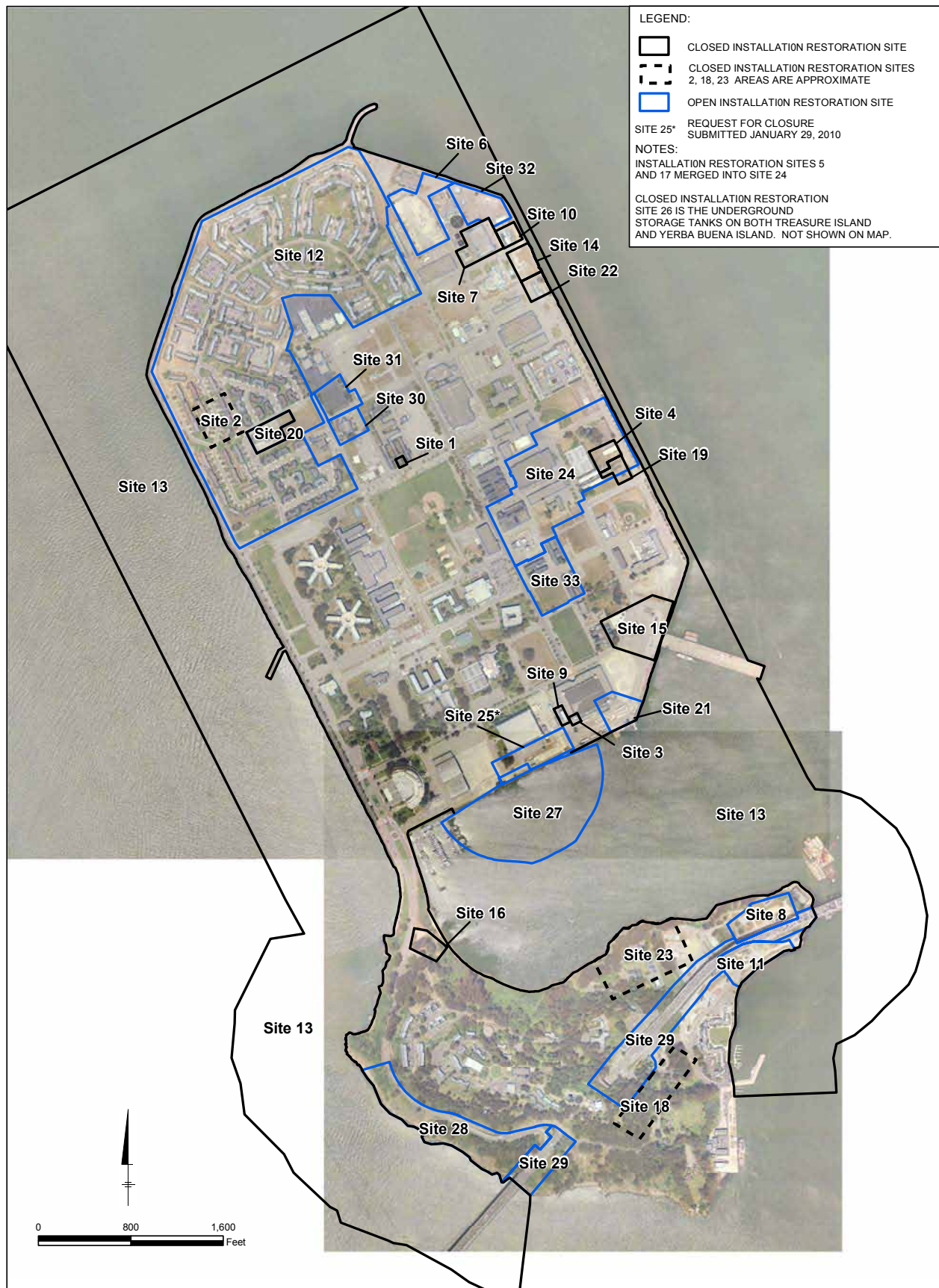

TREASURE ISLAND AND YERBA BUENA ISLAND REDEVELOPMENT PROJECT EIR

● FIGURE IV.P.1: INSTALLATION RESTORATION SITE INVENTORY

The Navy is currently conducting remedial actions, the goal of which is to eliminate the contamination, reduce it to acceptable levels, or, if residual contamination is left in place, to limit exposure pathways that may pose a risk to human health and the environment. The Navy's remedial activities fall under six programs:

- The Installation Restoration (IR) Program, which consists of the CERCLA Program and the Petroleum Program. The vast majority of the remedial activities conducted by the Navy fall within this category
- Inactive Fuel Pipeline Sites
- The PCB Program
- The Radiological Program
- The Lead-Based Paint Program
- The Asbestos-Containing Materials Program

The following subsections describe each of those programs.

The Installation Restoration Program

NSTI has been divided into IR sites as part of the Navy's IR program. A total of 34 sites have been identified for the NSTI IR program. Of these 34 sites, 22 sites are managed under the CERCLA program and 12 of these are managed under the Petroleum Program or have been merged into adjacent IR sites. One IR site, Site 26, includes all of the known underground storage tanks ("USTs") on NSTI. Table IV.P.1 presents a list of the numbered IR sites.¹⁶ Many of these IR sites (1, 2, 3, 4/19, 5, 7, 9, 10, 13, 14/22, 15, 16, 17, 18, 20, 23, and 26) have already received regulatory closure through risk assessment or remediation activities. Three sites (8, 11, and 29) are located on Yerba Buena Island outside of the Project Area and are not included in this analysis.¹⁷

All of the IR sites in Table IV.P.1 have received some degree of characterization work to identify the primary contaminants of potential concern ("COPCs") and remediation efforts to varying degrees including case closure. Contaminants become a potential concern if they have been identified as carcinogens or if at certain concentrations their toxicity has been found to have an adverse effect on human health or the environment. Some chemicals break down quickly in the environment; however, some may persist over years or even decades and accumulate over time to levels that may be harmful to the environment and organisms. Different contaminants have

¹⁶ In addition to the numbered IR sites, there are other identified sites or remedial activities. These fall under the PCB Program, the Radiological Program, the Lead-Base Paint Program, and the Asbestos-Containing Materials Program. Each of these programs is described below.

¹⁷ A portion of Site 29 may be transferred to Caltrans for the Yerba Buena Island Ramps Improvement Project, which is separate from the Proposed Project.

different toxic potencies and can have an impact upon different biological functions or parts of the environment.

● **Table IV.P.1: Treasure Island Installation Restoration Site Inventory**

Site	Program	Contaminants of Concern	Status
Site 1	CERCLA	Silver	Closed. Received agency (DTSC) concurrence on March 20, 2002.
Site 2	CERCLA	Radionuclides	Closed. Site recommended for NFA in 1988 Final PA/SI.
Site 3	CERCLA	PCBs	Closed. Received agency (DTSC) concurrence March 20, 2002.
Site 4/19	Petroleum	Petroleum, oil, lubricants	Closed. NFA concurrence letter received from Regional Water Board dated December 17, 2003.
Site 5	Petroleum	Petroleum	Closed. Merged into Site 24 by letter dated January 17, 2001.
Site 6	CERCLA	Dioxins, VOCs, SVOCs/Petroleum fuels and waste, VOCs, SVOCs	Open. Transferred from Petroleum Program on September 18, 2003.
Site 7	CERCLA	Metals, pesticides, herbicides	Closed. Received agency (DTSC) concurrence on November 1, 2005.
Site 8*	CERCLA	Metals and pesticides	Open. Interim RI report submitted in March 2009.
Site 9	CERCLA	Solvents, lead, petroleum products	Closed. No Action ROD signed (DTSC) October 2, 2007.
Site 10	CERCLA	Pesticides and SVOCs	Closed. No Action ROD signed (DTSC) October 2, 2007.
Site 11*	CERCLA	TPH, PAHs, VOCs, metals	Open. Final RI submitted on January 21, 2010.
Site 12	CERCLA	PCBs, TPH, PAHs, dioxins, arsenic, lead, Radium 226 and debris	Active. RI report being prepared. Soil/debris removal action is ongoing.
Site 13	CERCLA	Metals, PAHs, PCBs, DDT, TPH	Closed. No Action ROD signed April 7, 2005.
Site 14/22	Petroleum	Petroleum, oil, lubricants, VOCs	Closed. NFA concurrence letter received from Regional Water Board dated July 18, 2005.
Site 15	Petroleum	Petroleum, oil, lubricants	Closed. NFA concurrence letter received from Regional Water Board dated September 2004.
Site 16	Petroleum	Petroleum, oil, lubricants	Closed. NFA concurrence letter received from Regional Water Board dated June 17, 2004.

● **Table IV.P.1 (continued)**

Site	Program	Contaminants of Concern	Status
Site 17	Petroleum	Petroleum, oil, lubricants	Closed. Merged into Site 24 by letter dated January 17, 2001.
Site 18	CERCLA	Asbestos	Closed. Site recommended for NFA in 1988 Final PA/SI.
Site 20	Petroleum	Petroleum, oil, lubricants, VOCs	Closed. NFA concurrence letter received from Regional Water Board dated June 17, 2004.
Site 21	CERCLA	VOCs and TPH	Open. A final FFS was completed in February 2009.
Site 23	CERCLA	NA	Closed. Site recommended for NFA in 1988 Final PA/SI.
Site 24	CERCLA	Petroleum, oil, lubricants, chlorinated solvents	Open. Final RI/FFS submitted July 3, 2008. Expanded treatability study in progress.
Site 25	Petroleum	Petroleum, oil, lubricants	Open. Site Closure Request submitted January 29, 2010.
Site 26	Petroleum	Petroleum Hydrocarbons	Closed. Regulatory concurrence on closure or NFA from the Regional Water Board has been achieved for 79 known, suspected, or previously suspected USTs.
Site 27	CERCLA	Lead shot, lead, PAHs	Open. Revised FS report, inclusive of the sediment investigation results, was finalized on August 13, 2010.
Site 28	CERCLA	Lead	Open. RI Report was submitted in February 2009. Final ROD was completed in November 2010.
Site 29*	CERCLA	Lead	Open. Interim RI report was submitted in March 2009.
Site 30	CERCLA	Dioxins, lead, copper	Open. ROD was signed August 5, 2009. LUC work plan is being prepared.
Site 31	CERCLA	PCBs, PAHs, TPH, lead, copper, DDT, dioxins	Open. ROD signed on August 5, 2009. Remedial Design/Remedial Action Work Plan has been prepared.
Site 32	CERCLA	PCBs, TPH, dioxins, pesticides	Open. RI report was submitted October 2008. Removal action of PCBs is ongoing.
Site 33	CERCLA	Metals	Open. RI report is being finalized.

Notes:

NFA – No Further Action

ROD – Record of Decision

PA/SI – Preliminary Assessment/Site Investigation

PP – Proposed Plan

RI – Remedial Investigation

FFS – Focused Feasibility Study

FS – Feasibility Study

* Indicates site is not in the Project Area

Source: TetraTech, 2009 and TetraTech, 2010

The sites were all originally identified as part of the EBSs conducted for the BRAC and determined based on historical uses of these areas. All investigation and cleanup requirements for the sites are

- overseen by the EPA, DTSC, and the RWQCB. During the course of an investigation for soil and groundwater contamination, initial results are typically compared to regulatory screening levels or site specific action levels which help evaluate subsequent courses of action. However, final cleanup requirements are typically set on a site-by-site basis based on site specific exposure scenario analyses for human health and the environment. The site locations are shown on Figure IV.P.1, p. IV.P.10.

Underground Storage Tanks (Site 26)

Underground storage tanks (“USTs”) were widely used across both Islands to store fuels and oils for package heaters or boilers at individual buildings, backup power generators, gas stations, firefighter training activities, aviation, and storage of waste oil. The tanks were filled either through underground pipeline or by tanker truck. The majority of these USTs were installed in the 1940s and some were removed from service at various times in accordance with changes to building usage. By the 1980s, many of the USTs were out of service. Currently, all USTs on Navy property have been removed from service and the only remaining USTs on the Islands are operated by the United States Coast Guard at its facility on Yerba Buena Island. Collectively, all of the Navy’s USTs were included as part of IR site 26, which was investigated as part of the Petroleum Program. Regulatory concurrence on closure or no further action has been achieved for 79 known, suspected, or previously suspected USTs at both Islands. IR site 26 has received regulatory closure from the RWQCB.

Inactive Fuel Pipeline Sites

In addition to the Petroleum Program sites included within the IR Program (i.e. the Corrective Action Plan sites and the USTs), the Navy identified a number of inactive fuel pipelines that

- required remediation. Six main fuel lines were installed on Treasure Island as early as the 1940s and transported gasoline, diesel, bunker C fuel, and other petroleum products. Some fuel lines were inactive as early as 1945 while the remaining fuel lines were reportedly removed from service in 1989. These were never designated as IR sites, except for those pipelines that happen to cross an otherwise designated IR site, and the pipeline segments were numbered differently. The Navy completed a large Corrective Action Plan for the inactive fuel pipelines and implemented the recommended corrective actions at each site. All inactive fuel pipelines have received regulatory closure with the exception of a pipeline on IR Site 25 (discussed further below, under “Open IR Program Sites,” p. IV.P.17), and a separate site on Yerba Buena Island known as YF3. Outstanding environmental issues at inactive Fuel Line YF3, identified by the Petroleum Program will be

addressed after the completion of the San Francisco – Oakland Bay Bridge (“Bay Bridge”) construction activities.¹⁸

Radiological Assessment Program

Radiological contamination has been identified by the Navy as one of the contaminants of concern at NSTI. Radiological contamination is generally handled outside of the CERCLA process. By law, the Navy retains responsibility for all radiological contamination, and must be responsible for its remediation. The Navy conducted a base-wide Historical Radiological Assessment (“HRA”) to document use of radioactive materials and to present a comprehensive history of radiological operations conducted by the Navy at NSTI. Five sites were identified for further evaluation: Building 233, Building 233 drain lines, Site 12 SWDAs, and Buildings 343 and 344.

There is one IR Site, Site 12 (discussed further on p. IV.P.18), where low-level radiological materials have been found among the buried debris where numerous solid waste disposal areas were located.

A summary report prepared by LFR in 2008 on environmental conditions on NSTI identified several other IR sites (Sites 6, 30, 31, and 33) where radiological contamination might be found due to the presence of solid waste disposal areas on those sites. However, the Navy has conducted, or has plans for additional screenings at these sites. To date, the existing data indicates that the only known remaining low-level radiological material contamination at the Naval base is isolated to small portions of Site 12 and Building 233.¹⁹ The Navy is currently removing the radiological contamination at Site 12. Building 233 (located east of IR Site 33) was a former radiation training facility and had a known release of 50 milligrams of radium sulfate in 1950. The spill was remediated at the time to the relevant standards of that era, which are less stringent than current standards. The Navy has conducted a recent radiological survey of the building and will develop a work plan for demolition and clean up of the radiological contamination present.²⁰ The radiological cleanup of both Site 12 and Building 233 will occur prior to regulatory closure, which will be obtained prior to transfer. TIDA cannot accept any property with known radiological contamination. If any radiological materials are subsequently discovered during construction activities, the Navy would

¹⁸ Arcadis, *Review of Current Conditions regarding Low-Level Radiological Material Contamination at Former Naval Air Station Treasure Island, San Francisco, California*, April 19, 2010 (hereinafter “*Review of Current Conditions*, 2010”). A copy of this document is available for public review at the San Francisco Planning Department, 1650 Mission Street, Suite 400, in Case File No. 2007.0903E.

¹⁹ *Review of Current Conditions*, 2010.

²⁰ *Review of Current Conditions*, 2010.

be responsible and required to perform any necessary remedial activities to obtain “free release” of the subject property.²¹

A radiological status survey for Buildings 343 and 344 and Building 233 drain lines was conducted in September 2007. In 2008, Final Status Survey Reports were prepared for Buildings 343 and 344. The Buildings 343 and 344 and the Building 233 Drain Lines Scoping Survey Reports were finalized in the fall 2008. DTSC and California Department of Public Health provided free release for Buildings 343 and 344 in 2008.²²

Polychlorinated Biphenyls Program

- The Navy performed investigations of all known former PCB-containing equipment across both Treasure Island and Yerba Buena Island in 2004 and 2006, including transformers and fluid-filled electrical equipment. PCB abatement was performed at some locations in 2008 and a removal action was completed at Site 32 under the Toxic Substances Control Act (“TSCA”) PCB remediation program in early 2010. IR Sites 3, 7, 9, 10, 11, 12, 21, 24, 31, and 32 have been investigated under CERCLA for PCBs along with other contaminants.²³

Residential Lead-Based Paint Program

- The Residential Lead-Based Paint Hazard Reduction Act of 1992, Title X of the Housing and Community Development Act (Public Law No. 102-550), applies at NSTI. To date, lead-based
- paint at all pre-1978 housing on Treasure Island and Yerba Buena Island has been assessed and either abated or covered with encapsulating paint. Re-evaluation surveys are conducted every two years. Housing on both Treasure Island and Yerba Buena Island will be re-evaluated again in 2011 or within 1 year of transfer, whichever comes first.
 - Soil samples of planter boxes, drip line and mid-yard areas at representative Treasure Island and Yerba Buena Island residential buildings were also taken and, based on analytical results, soil abatement was conducted in accordance with Title X, Department Housing and Urban Development and Navy Policy. Any future disturbance of the grasses, concrete or asphalt over soil on these building sites (located at Quarters 1 through 7, 10, and Buildings 62, 83, 205, and 230 on Yerba Buena Island) will require further soil evaluation for lead. The Navy will either abate or require the transferee to abate lead-based paint hazards found in existing residential facilities within 1 year of being transferred. If an existing residential facility is scheduled for demolition or nonresidential use, it will not be inspected or abated for lead-based paint.

²¹ A designation of “free release” or “unrestricted release” is a specific term used by the Department of Public Health that refers to standards regarding the clearance of materials that either contained or were suspected of containing radiological contamination.

²² *Review of Current Conditions*, 2010.

- ²³ Tetra Tech, Inc., *Draft 2010 Site Management Plan, Naval Station Treasure Island, San Francisco, CA*. April 19, 2010 (hereinafter referred to as “*Draft 2010 Site Management Plan, NSTP*”). A copy of this document is available for public review at the San Francisco Planning Department, 1650 Mission Street, Suite 400, in Case File No. 2007.0903E.

Asbestos-Containing Material Program

- Beginning in 1995, surveys were completed at NSTI to identify the presence of asbestos-containing material (“ACM”). All damaged, friable or accessible ACM that was known about at that time was abated within the Treasure Island and Yerba Buena Island FOST areas. Buildings with remaining ACM are subject to notices and restrictions, were identified in the FOST for both Treasure Island and Yerba Buena Island dated February 15, 2006 and March 23, 2006, and all remaining ACM are periodically re-evaluated. Re-evaluations of the remaining ACM occurred in 2009. The 2009 re-evaluation identified additional damaged, friable, or accessible ACM in some buildings. The Navy’s deed transferring the property is expected to contain a restriction requiring that TIDA prohibit occupancy and use of the buildings and structures, or portions thereof, containing known asbestos hazards before abatement of such hazards.

OPEN IR PROGRAM SITES

The following presents a summary of NSTI IR sites in the Project Area that at the time of preparation of this EIR remain as “open sites,” (i.e. lacking regulatory approval that investigation and any necessary remediation are complete), under any of the Navy’s remedial programs. All the IR sites discussed in this section will require further work prior to receiving site closure from the regulatory agencies (DTSC or RWQCB). The information presented here is largely obtained from the summary report prepared by LFR (now Arcadis) in 2008 with some updated information obtained from the Navy’s 2009 Site Management Plan and the Navy’s Draft 2010 Site Management Plan, both by Tetra Tech, as well as information found in the DTSC Envirostor database.^{24,25,26,27}

Site 6 – Fire Training School (Treasure Island)

Site 6 is the location of the former Fire Training School, which operated from 1944 to approximately 1992.²⁸ Site 6 occupies approximately 3.4 acres in the northeastern portion of the island. The training school included 23 buildings, 6 former underground storage tanks (“USTs”) used for fuel (gasoline and diesel), and a central training yard, which consisted of burn areas lined with asphalt and concrete. Fires fueled with diesel, gasoline, magnesium, and wood were set in

²⁴ LFR, Inc., *Final Summary of Environmental Conditions and Preliminary Site Closure Strategies Former Naval Air Station Treasure Island, San Francisco, California*, June 12, 2008 (hereinafter “*Final Summary of Environmental Conditions*, 2008”). A copy of this document is available for public review at the San Francisco Planning Department, 1650 Mission Street, Suite 400, in Case File No. 2007.0903E.

²⁵ Tetra Tech, Inc., *2009 Site Management Plan, Naval Station Treasure Island, San Francisco CA*, September 28, 2009 (hereinafter referred to as “*2009 Site Management Plan, NSTI*”). A copy of this document is available for public review at the San Francisco Planning Department, 1650 Mission Street, Suite 400, in Case File No. 2007.0903E.

²⁶ *Draft 2010 Site Management Plan, NSTI*.

²⁷ Department of Toxic Substances Control (DTSC), EnviroStor Database, Sites 6, 12, 21, 24, 27-28, and 30-32 (hereinafter referred to as “DTSC 2009”). http://www.envirostor.dtsc.ca.gov/public/profile_report.asp?global_id=60001091 through =60001099, p. 1, accessed September 16, 2009.

²⁸ DTSC 2009, for Site 6.

various mockups in the training yard and were extinguished with a mixture of water, biodegradable soap, and industrial talc. Wastewater and unburned gasoline and diesel were collected in a concrete collector trench, passed through an oil-water separator, and discharged to the wastewater treatment plant. The USTs each had a capacity of 1,500 gallons and were removed between 1995 and 2002. In addition, all buildings have also been removed from the site.

Environmental documents have identified the following COPCs at the site: petroleum hydrocarbons (gasoline, diesel, and waste fuels), aromatic VOCs, PAHs, SVOCs, and dioxins in soils. These COPCs have been detected in the soil and only petroleum hydrocarbons have been identified in the groundwater. The site was originally part of the Navy's IR Petroleum Program and has transferred to the Navy's IR CERCLA Program. The full extent of contamination has not yet been fully characterized and remediation activities beyond removal of the USTs and petroleum contaminated soils have not yet been completed for the site. An RI report will not be completed until the remaining data gaps are filled including a soil gas investigation for the presence of VOCs. The site is currently undergoing groundwater monitoring for the presence of petroleum hydrocarbons. The final site closure has been estimated for September 2015.²⁹

A potential for low level radiological waste was identified at this site by LFR in their 2008 report due to its close proximity to IR Site 12 (discussed below).³⁰ Subsequent to the LFR report, the Navy has performed radiological surveys at Site 6 and has not found any radiological contamination at these sites prior to or during soil removal activities.³¹ Site 6 is currently being used as a staging area for bins from the clean-up of low-level radiological material contamination at IR site 12. The Navy will conduct a multi-agency radiation survey (Final Status Survey using MARSSIM method) and site investigation at Site 6 (following completion of IR site 12 radiological clean-up) prior to final transfer of Site 6.³²

● **Site 12 – Old Bunker Area (Treasure Island)**

This 93-acre site is located on the northwestern part of Treasure Island; current building stock consists primarily of housing. The housing units were constructed in four phases between 1967 and 1989. Prior to the residential land use, portions of this area were used for ammunition storage, debris and trash disposal, waste incineration, decontamination training with short-life radionuclide liquid, vehicle parking, an aircraft landing strip, solid waste storage, and oil storage. Site 20, a closed petroleum site, is located within the Site 12 area and encompasses 1.6 acres that are fully encircled by Site 12. For several decades beginning in the 1940s, 21 ammunition bunkers were located at this site. Soil trenching conducted in preparation for construction of the

²⁹ *Draft 2010 Site Management Plan, NSTI.*

³⁰ Historically, IR Site 12 was used as a waste disposal site that included disposal of radiological materials.

● As a result, some low level radiological waste was encountered in near-surface soils up to five feet below ground surface.

³¹ *Review of Current Conditions, 2010.*

³² *Review of Current Conditions, 2010.*

housing units in 1965 determined that areas around the bunkers were used for solid waste disposal. Disposal activities have reportedly included household waste, construction debris, trash incinerator ash, devices contaminated with low-level radiological materials, and sandblast grit.

The COPCs for the soils at the site include dioxins, metals, PAHs, petroleum hydrocarbons, pesticides, PCBs, and low-level radiological wastes. In addition, the presence of the disposal waste has led to the presence of low levels of methane gas. In general, the disposal debris was encountered within four Solid Waste Disposal Areas at a depth of up to 4 feet below ground surface (“bgs”) with some instances at depths of 10 feet bgs. These disposal areas are described as the solid waste disposal areas in Site 12. These disposal areas make up approximately 12 acres within Site 12. Concentrations of lead, PCBs, and PAHs have reportedly been found during previous investigations to be above action levels protective of human health in the solid waste disposal areas. At the time of preparation of this document, the radiologically contaminated wastes have not been fully characterized for the site, but are likely confined to the solid waste disposal areas. Debris buried beneath existing building foundations within the Site 12 solid waste disposal areas may contain contamination including low levels of radiological material.³³ Access to these areas would not be feasible until demolition of the existing structures occurs. Excavation protocols for areas where low level radiological contamination may exist have been required by the regulatory agencies and the Navy; these protocols have already been implemented in the removal actions in the solid waste disposal areas.

A Non-Time-Critical Removal Action began in May 2007 at three solid waste disposal areas along the shoreline of Site 12. The Navy is currently excavating and screening soils for chemical and radiological contaminants. During this removal action, low level radiological items

- containing radium-226 have been found within the solid waste disposal areas. All items found in the excavated soil located at these three areas are being removed and disposed of in accordance with regulatory requirements. Soil that may have been impacted by these items was screened prior to shipment off-site by a licensed disposal contractor. Confirmation samples are being collected in the solid waste disposal areas once excavations are completed. Final status surveys of the solid waste disposal areas will be performed in accordance with a Multi-Agency Radiation Survey and Site Investigation Manual upon completion, which is estimated to be in 2010.³⁴

- In certain areas, the shallow groundwater on a small portion of Site 12 has been contaminated with petroleum hydrocarbons, arsenic, and copper. The Navy is currently monitoring seven groundwater monitoring wells at Site 12 in the area of Buildings 1311 and 1313 for the presence of total petroleum hydrocarbons, arsenic, and other metals. In 2009, the Navy conducted some additional investigation for the arsenic pilot study at the Building 1321 area of Site 12 where free floating petroleum hydrocarbons were found on the water table.

³³ 2009 Site Management Plan, NSTI.

³⁴ Review of Current Conditions, 2010.

Soil gas investigations have also been conducted on a small portion of Site 12 to determine whether contaminated soil gas vapors might be present. In some cases, harmful soil gas vapors can emanate from underlying contaminated subsurface soils. Concentrations of VOCs, methane, and chloromethane have been detected in the solid waste disposal areas, and specifically near

- Buildings 1319, 1321, and 1323 of Site 12. Confirmation soil sampling associated with the removal actions in the areas was also completed in 2009; removal actions included radiological surveys.

In addition to a completed RI for Site 12, the Navy plans to complete a human health risk assessment for the site. These documents will provide data regarding levels of contamination and

- potential threats to human health and the environment. The FS will use all the collected data from the RI and the risk assessment to guide the selection of appropriate remediation alternatives. The ultimate goal of this process is to obtain site closure where there is no threat to human health or the environment based on proposed future uses, potential exposure pathways and risk-based action levels. Remediation goals will require completion of all data gaps and a completed HHRA. The final site closure has been estimated for December 2015.³⁵

Site 21 – Vessel Waste Oil Recovery Area (Treasure Island)

Site 21 is an approximately 2 acre site directly adjacent to Clipper Cove on Treasure Island, where waste oil was unloaded from ships and transferred to an onshore oil/water separator. The facility consisted of five above ground storage tanks (“ASTs”) that had capacities of 2,000 gallons each. The tanks were located above a paved area that was reported to be heavily stained prior to the removal of the tanks in 1995. Several buildings, including historic Building 3, remain at the site and were used for aircraft maintenance and cleaning. No records are available that describe the types and quantities of chemicals used or disposed of during parts cleaning operations; however, use of the solvents tetrachloroethene (“PCE”) and trichloroethene (“TCE”) as degreasing agents for cleaning metal parts was widespread at the time of Navy operations. Open tanks or dip tanks were filled with cleaning solvents and used to submerge mechanical parts for cleaning. Contamination of groundwater at Site 21 is believed to have resulted from small spills of PCE and TCE in the dip tank area during parts cleaning operations.

The COPCs for the site include petroleum hydrocarbons and chlorinated solvents (PCE and TCE). These COPCs have impacted both soil and groundwater at the site. The Navy is currently in the process of evaluating remediation alternatives for the site that may include bioremediation, a technology that uses microorganisms to naturally break down contaminants into water and harmless gases. A final focused feasibility report was completed in February 2009; three alternative remediation strategies for the site were included, including a no action strategy, an

³⁵ *Draft 2010 Site Management Plan, NSTI.*

institutional controls strategy, and *in situ* bioremediation.³⁶ The final site closure has been estimated for December 2017.³⁷

Site 24 – Dry Cleaning Facility (Treasure Island)

Site 24 sits on the eastern edge of Treasure Island. This approximately 20-acre site is the former home of a dry cleaning facility; in addition, this site included a number of buildings used for general storage, petroleum storage facilities, a boiler plant, and a former Hydraulic Training School and Refuse Transfer Area. After 1977, the southern portion of Building 99, which once housed the dry cleaning facility, was reconfigured and used for meat processing and storage, office space, and workshops for movie sets. Various chemicals may have been used during the boiler operations to prevent scaling. Typical chemicals used to prevent scaling include morphaline, caustic soda, sulfite, and brine. It is reported that building debris, including asbestos-containing materials, were buried where the building once stood.

Site 24 also includes two former CERCLA sites (IR Sites 05 and 17) and four Petroleum Program sites (Site 04/19; fuel line sites D1A, D4B, F2B, and a portion of F2A; Building 230 Fuel Line Site; and Former UST 230) that have received closure with no further action from the DTSC and RWQCB.

The COPCs at Site 24 consist of chlorinated solvent VOCs (including PCE) and petroleum hydrocarbons, which have been detected in both soil and groundwater. Extensive site characterization work has been completed for this site but there may be some data gaps that will be addressed through existing regulatory requirements discussed further on pp. IV.P.27 – IV.P.36. A final RI and focused FS have been completed; however, an expanded treatability study is currently in progress.³⁸ The final site closure has been estimated for October 2017.³⁹

Site 25 – Former Seaplane Maintenance Area (Treasure Island)

Site 25 is an approximately 3-acre site located on the southern portion Treasure Island. The site was used as a maintenance area for seaplanes as well as for storage of petroleum products, skeet range operations (see discussion of Site 27 below for definition), vehicle maintenance, ammunition and weapons storage, and reserve training. The site was also used by the Pan American Airways Systems China Clipper Service from 1939 to 1946. As part of those operations there were nine 4,000 gallon USTs used to store petroleum fuel. In addition, a steel pipeline used to convey petroleum fuel, known as the causeway pipeline, was located at the site

³⁶ Institutional controls include deed restrictions and other land use controls that would limit or cut-off potential exposure pathways. Sultech, *Focused Feasibility Study Report for Installation Remediation Site 21 Vessel Waste Oil Recovery Area*, February 2009.

³⁷ *2009 Site Management Plan, NSTI.*

³⁸ *Draft 2010 Site Management Plan, NSTI.*

³⁹ *Draft 2010 Site Management Plan, NSTI.*

and was partially abandoned in place and partially removed in 2001. The site also included a fuel pump house. This site has been closed as a CERCLA site and is only open as a petroleum site and managed under the Petroleum Program.

The COPCs for the site soils include petroleum hydrocarbons, VOCs, and metals. Groundwater has been contaminated by petroleum hydrocarbons. However, the site has not been fully characterized to date. Groundwater monitoring is being conducted to monitor levels of contamination in the groundwater, with elevated levels continuing to be recorded. In addition, the Navy installed and operated a soil-vapor extraction system at the site to remove petroleum hydrocarbon soil vapors.

In 2005, a request for site closure and no further action was made by the Navy and granted by the RWQCB. However, it was reopened due to concerns expressed by the City and County of San Francisco regarding potential high petroleum hydrocarbon concentrations in deeper soil. The Navy has conducted further characterization work and again submitted a request for site closure to the RWQCB.

Site 27 – Clipper Cove Skeet Range (Treasure Island and Yerba Buena Island)

- Clipper Cove is located between the Islands. Site 27 encompasses approximately 19 off-shore acres in the cove area, as well as approximately 1 acre of onshore land on Treasure Island. From approximately 1979 to 1989, a portion of the cove was used as a naval skeet range where lead shot was used to fire at targets. As a result, lead shot and clay targets were deposited in the submerged sediment in the cove. The clay targets were found to contain PAHs. Additional investigation of lead and PAHs in the onshore soils of IR Site 27 was conducted in 2004. In September 2005, a hydrographic study was conducted to evaluate sedimentation rates and deposition in Clipper Cove. The results indicated steady-state conditions and sediment thickness may not be protective of diving ducks within 150 feet of the shoreline; therefore, an additional sediment investigation to characterize the distribution of lead shot in near-shore sediments was conducted in March 2008. The investigation indicated that lead shot is covered by only 1 foot of sediment in some near-shore locations. The final FS report was published on August 13, 2010 and includes these sediment investigation results.⁴⁰ The final site closure has been estimated for July 2013.⁴¹
-

Site 28 – West Side On/Off Ramp (Yerba Buena Island)

Site 28 is an approximately 10.5-acre site that runs along Treasure Island Road as it approaches the Bay Bridge. Treasure Island Road on the western portion of Yerba Buena Island has been in operation since the Bay Bridge was constructed in 1936. The soil beneath and surrounding this area of Yerba Buena Island has been contaminated with metals such as lead from vehicle

⁴⁰ 2009 Site Management Plan, NSTI.

⁴¹ Draft 2010 Site Management Plan, NSTI.

emissions and bridge maintenance activities. The Navy owned the property comprising the ramps and the area beneath the Bay Bridge until 2001, when the bridge right-of-way and ramps transferred from the Navy to FHWA/Caltrans.⁴² No remediation has occurred to date and none is reportedly anticipated for the site. The RI was finalized in 2009 and the Navy has just recently issued the Final ROD in November 2010. The site is being recommended for no further action based on the low level of human health and ecological risks identified in surface soils. Final site closure has been estimated for December 2010.⁴³

Site 30 – Daycare Center (Treasure Island)

The Daycare Center building (Building 502) is located in the central portion of Treasure Island and was constructed in 1985. Site 30 includes the Daycare Center and associated parking lot, and totals approximately 1.5 acres. Past land use activities resulted in releases of hazardous materials to the subsurface. The COPCs at Site 30 include metals and dioxins which are considered to have originated from buried debris located at and adjacent to the site. In 2002, a series of investigations identified various types of wastes, including buried burned debris (consistent with historical practices) that contained lead and dioxins at concentrations that exceeded regulatory soil screening levels. The Navy continued to investigate the site in an effort to delineate the extent of the burned debris and dioxin contamination; however, some of the soil containing burned debris was not accessible without compromising the building foundation and could not be removed. The LFR summary report indicated a potential for low-level radiological materials beneath the site based on the proximity to suspected radiological debris at neighboring Site 12.⁴⁴

Since then, a subsequent radiological screening for health and safety of workers has been conducted for Site 31, which is immediately adjacent to Site 30, and negative results for this screening indicated no potential radiological contamination was present.⁴⁵ Additional radiological screening will be included in the upcoming soil removal workplan amendment for the site. In addition, the Record of Decision (“ROD”) for Site 30, which has been approved by the regulatory agencies, does not identify low-level radiological material contamination as a potential constituent of concern.⁴⁶

Some remediation activities have already occurred at the site in the form of excavation and removal of contaminated soils containing metals and dioxins. The contamination has been found to exist primarily in site soils. A ROD was signed on August 5, 2009 indicating the agency-approved (DTSC) concrete cap installed in 2003 precludes any potential exposure pathways. Land use controls are currently being prepared to ensure that future users are not exposed to

⁴² 2009 Site Management Plan, NSTI.

⁴³ Draft 2010 Site Management Plan, NSTI.

⁴⁴ Final Summary of Environmental Conditions, 2008.

⁴⁵ Review of Current Conditions, 2010.

⁴⁶ Barajas & Associates, Site 30- Day Care Center Record of Decision/Remedial Action Plan, prepared under Naval Facilities Engineering Command for the BRAC Program, July, 2009.

remaining contamination left in place beneath the cap. The final site closure has been estimated for August 2010.⁴⁷

Site 31 – Former South Storage Yard (Treasure Island)

Site 31, known as the Former South Storage Yard, is also located in the central portion of Treasure Island. The 0.8-acre site was developed as an elementary school in the late 1960s and served various purposes prior to that. Prior to construction of the school, the site was used as a storage yard and also for solid waste disposal. The COPCs at the site include petroleum hydrocarbons, metals, PCBs, PAHs, and dioxins. As mentioned above, the 2008 LFR summary report identified a potential for some of the debris buried at the site to contain devices contaminated with low-level radiological materials. However, a subsequent radiological survey has been conducted for health and safety purposes at Site 31 and negative results indicated no potential radiological contamination was present.⁴⁸ The site has been the subject of extensive characterization work to identify sources and the extent of contamination from the previously mentioned COPCs. The Navy has identified four debris areas that require excavation and removal of debris/soils. A ROD was signed on August 5, 2009 and a Remedial Design and Remedial Action Plan was submitted in January 2010. Soil excavation as the remedial action is currently underway, scheduled for the spring and summer of 2010. The final site closure has been estimated for October 2010.⁴⁹

Site 32 – Former Training and Storage Area (Treasure Island)

Site 32 is located in the northeastern portion of Treasure Island and consists of 2.7 acres known as the Former Training and Storage Area. Open spaces at the site were used for parking vehicles and forklifts as well as outdoor storage of a variety of materials that included hazardous and non-hazardous materials. A portion of this site was also used for tear gas training. The various buildings on the site were used as administrative offices, tear gas training, storage of pyrotechnics and small arms, maintenance shops, incinerators, refuse, a paint shop, salvage, linoleum shop, and a mason's locker. Historically, the site was also used for radiological decontamination training. However, the Navy conducted a radiological assessment that evaluated past operations in the vicinity and determined that radiological issues at Site 32 were not a concern.⁵⁰ The Site 32 area was originally designated for investigation because fluid that contained PCBs was known to have been released from the former transformer in addition to other past uses.

The COPCs at the site include petroleum hydrocarbons, PCBs, dioxins, PAHs, metals and pesticides in the soil. Several metals including arsenic, copper, lead, mercury, nickel, silver, and

⁴⁷ *Draft 2010 Site Management Plan, NSTI.*

⁴⁸ *Review of Current Conditions, 2010.*

⁴⁹ *Draft 2010 Site Management Plan, NSTI.*

⁵⁰ *Review of Current Conditions, 2010.*

zinc have been detected in the groundwater. Numerous site investigations have been performed at the site. Most recently, the Navy has completed a significant excavation to address PCB and petroleum contaminated soils as well as dioxin, pesticides and metals, primarily arsenic. The majority of the site has been excavated and backfilled.⁵¹ As a result of this work and other findings, the Navy intends to update the RI and HHRA to reflect this removal of source material; in the meantime, the recent soil removal was completed in March 2010.⁵² The final site closure has been estimated for September 2014.⁵³

Site 33 – Water Line Replacement Area (Treasure Island)

The Water Line Replacement Area encompasses 4.9 acres and contains three buildings as well as paved parking areas. The site is located in the southeastern portion of Treasure Island. A water exhibit for the exposition in 1939 was originally constructed at this site but was later filled in and replaced by barracks. One of the buildings on the site, Building 92, was used as a naval hospital, barracks, classrooms, offices, and miscellaneous storage. Other buildings at the site were used for various purposes such as offices, barracks, classrooms, a supply center, and a police station. Construction activities in the 1980s discovered buried debris that is associated with hazardous materials releases.

The COPCs consist of metals and dioxins. Investigations of the site have included trenching to establish the extent of buried debris at the site. Buried debris has been identified along Avenue I between 4th and 5th Street that will require remediation. The 2008 LFR summary report also identified a potential for low-level radiological materials at Site 33; however, it is not included as a COPC in the more recent Site Management Plan for the base cleanup activities.⁵⁴ The Navy's current plan is that Site 33 will follow the protocols set forth in the ROD/RAP for Site 31, which requires a preliminary screening for low-level radiological material contamination for worker health and safety purposes.⁵⁵ Remediation will most likely involve excavation and removal of the debris as overseen and approved by the DTSC. To date, a total of 49 trenches have already been excavated at the site where soil samples and visual observations were taken. The current Navy schedule includes a finalized RI report with the final site closure estimated for June 2013.⁵⁶ However, the Navy's current plan is to expedite the remediation and transfer by linking the Site to the ROD at Site 31. Under this scenario, the remediation and screening work at Site 33 would occur prior to transfer of the site.

⁵¹ Shaw Environmental (Shaw), *Excavation Status Figure 2A, Site 32 Parcel T111*, October 9, 2009.

⁵² *Draft 2010 Site Management Plan, NSTI.*

⁵³ *Draft 2010 Site Management Plan, NSTI.*

⁵⁴ *2009 Site Management Plan, NSTI.*

⁵⁵ *Review of Current Conditions, 2010.*

⁵⁶ *Draft 2010 Site Management Plan, NSTI.*

ONGOING LEAD-BASED PAINT ACTIVITIES

The Navy has completed lead-based paint assessments for all pre-1978 housing on both Islands. Lead-based paint at all pre-1960 Yerba Buena Island housing has been abated, and hazard reduction measures were put in place to protect current residents. A re-evaluation survey is conducted every 2 years per the recommended U.S. Department of Housing and Urban Development (“HUD”) schedule to monitor the continued effectiveness of these reduction measures. Surveys have been completed in 2004, 2006 and most recently in late 2008 with a finalized report due in 2010. Housing on both Islands must be re-evaluated again in 2011 or within 1 year of transfer, whichever occurs first.

Soil samples were also collected to evaluate the status of drip line and mid-yard areas at representative residential buildings on both Islands. Based on the analytical results, soil abatement of the planter boxes and drip line areas was conducted in accordance with Title X, HUD, and Navy Policy at Quarters 1 through 7, 10, and Buildings 62, 83, 205, and 230 on Yerba Buena Island. HUD guidelines state that only bare soils may pose a hazard, and soils covered by grass, concrete, or asphalt are protective. Any future disturbance of the grass, concrete, or asphalt at these buildings will require further soil evaluation for lead. The Navy will either abate or require the transferee to abate any lead-based paint hazards found in existing residential facilities within 1 year of being transferred. If an existing residential facility is scheduled for demolition or nonresidential use, it will not be inspected or abated for lead-based paint.

ONGOING ASBESTOS CONTAINING MATERIALS ACTIVITIES

Several ACM surveys have been completed at NSTI dating back to 1995. The Navy first conducted an asbestos survey of 108 major nonresidential buildings which was reported in 1995. In 1997, Radian, Inc. completed a more comprehensive asbestos survey for a total of 212 nonresidential buildings, including an inspection of the 108 buildings previously surveyed. In 1998, an asbestos survey of underground steam utility lines and miscellaneous facilities was conducted. Results of the survey indicated that ACM-wrapped pipes exist only within a portion of the property, as discussed further in the FOST.⁵⁷

Friable, accessible ACMs identified from these surveys were remediated initially in 38 buildings in 1998 and then later in the year an additional 20 buildings. In 1999, friable ACMs found in residences at both Islands were remediated. To date, all known damaged, friable, or accessible ACM has been abated within the Treasure Island and Yerba Buena Island FOST areas, and remaining ACM does not pose a threat to human health. Notices and restrictions related to asbestos were identified in the FOST for both Islands dated February 15, 2006, and March 23, 2006, respectively. A re-evaluation of

⁵⁷ *Review of Current Conditions*, 2010, p. A-55.

ACMs began in 2008 and reports will be finalized in 2010. A re-evaluation of ACM is planned in 2011 or within one year of transfer, whichever occurs first.⁵⁸

REGULATORY FRAMEWORK

Federal

United States Environmental Protection Agency

In 1992, the Navy entered into a Federal Facilities Site Remediation Agreement with the EPA, DTSC, and the RWQCB for the cleanup activities at NSTI.⁵⁹ The Federal Facilities Site Remediation Agreement established roles and responsibilities between the Navy, EPA, the RWQCB and DTSC regarding site characterization and remediation for each distinct contaminated area of Navy property (e.g. each Installation Restoration site) as well as a schedule of implementation. The Navy's resultant Installation Restoration Program consists of two primary programs: the Comprehensive Environmental Response, Compensation, and Liability Act program and the Petroleum Program. The EPA is a participating agency in the cleanup activities at NSTI, and all documents prepared for each parcel are circulated to the EPA as well as DTSC, the RWQCB, the City and County of San Francisco, the Restoration Advisory Board ("RAB") for review. The EPA has delegated much of the day to day responsibilities of oversight of each clean up activity to the state regulatory agency (DTSC or RWQCB) but also contributes to determining the schedule of completion for each site.

Comprehensive Environmental Response Compensation and Liability Act

CERCLA, commonly known as Superfund, is the legal framework for the identification and restoration of contaminated property. In addition, CERCLA:

- Established prohibitions and requirements concerning closed and abandoned hazardous waste sites;
- Provided for liability of persons or entities responsible for releases of hazardous waste at these sites; and

Generally, CERCLA authorizes two kinds of response actions:

- Short-term removals, where actions may be taken to address releases or threatened releases requiring prompt response.
- Long-term remedial response actions, that permanently and significantly reduce the dangers associated with releases or threats of releases of hazardous substances that are serious, but not immediately life threatening.

⁵⁸ *Review of Current Conditions*, 2010.

⁵⁹ *Final Summary of Environmental Conditions*, 2008.

The Superfund Amendments and Reauthorization Act (“SARA”) (Public Law 99-499), amended CERCLA in 1986, and added certain specific provisions applicable to the cleanup of contaminated sites at Federal facilities. Section 120 of those amendments addressed the cleanup of federal facilities. Under Section 120(a)(1), CERCLA specifies that Federal departments, agencies, and instrumentalities must comply with CERCLA in the same manner and to the same extent as non-governmental entities.

DTSC is the lead agency for the CERCLA sites, with the EPA having review and comment authority; however, the DTSC is the primary CERCLA administrator.

Radioactive Materials

Pursuant to the federal Atomic Energy Act of 1954, later amended by the Energy Reorganization Act of 1974, the United States Department of Energy (“DOE”) regulates the storage and use of sources of ionizing radiation (radioactive material and radiation-producing equipment). Radiation protection regulations require control of sources of ionizing radiation and radioactive material and protection against radiation exposure. DOE regulations concerning occupational radiation exposure are prescribed in Title 10, Code of Federal Regulations, Section 835, Occupational Radiation Protection. These regulations specify appropriate worker safety precautions and worker health monitoring programs. Radiation protection requirements for the public and the environment are prescribed in DOE Order 5400.5, “Radiation Protection of the Public and the Environment.”

DOE regulates radioactive waste and the radioactive portion of mixed waste⁶⁰ pursuant to the Atomic Energy Act and DOE Order 435.1, Radioactive Waste Management.

State

Department of Toxic Substances Control

Under the California Hazardous Waste Control Act, California Health and Safety Code, Division 20, Chapter 6.5, Article 2, Section 25100, *et seq.*, DTSC (a division of the California Environmental Protection Agency) regulates the generation, transportation, treatment, storage, and disposal of hazardous waste in California. The Federal Resource Conservation and Recovery Act of 1976 (“RCRA”) established a “cradle-to-grave” regulatory program for governing the generation, transportation, treatment, storage and disposal of hazardous waste. Under RCRA, individual states may implement their own hazardous waste programs in lieu of RCRA, as long as EPA has determined the state program is at least as stringent as Federal RCRA requirements. California’s hazardous waste program has been federally approved. Thus in California, DTSC enforces hazardous waste regulatory requirements. The hazardous waste regulations establish

⁶⁰ Mixed waste contains both radioactive materials and other hazardous materials.

criteria for identifying, packaging, and labeling hazardous wastes; dictate the management of hazardous waste; establish permit requirements for hazardous waste treatment, storage, disposal, and transportation; and identify hazardous wastes that cannot be disposed of in landfills.

DTSC is also the administering agency for the California Hazardous Substance Account Act. California Health and Safety Code, Division 20, Chapter 6.8, Sections 25300 et seq., also known as the State Superfund law, providing for the investigation and remediation of hazardous substances pursuant to State law.

In addition, under California Education Code Section 17210 through 17224 and related statutory provisions, DTSC works with the California Department of Education and the School Facilities Planning Division oversee the environmental investigation and remediation of properties to be developed for use as schools. Under those provisions, California school districts must prepare a Phase I Environmental Site Assessment and/or a Preliminary Endangerment Assessment (“PEA”) to identify potential contamination and evaluate whether it presents a risk to human health or the environment at proposed or expanding school properties that will be funded pursuant to the Leroy F. Greene School Facilities Act of 1998. If the PEA uncovers a release or threatened release of hazardous materials, or the presence of naturally occurring hazardous materials at concentrations that could pose a significant risk to human health, and the school district owns the proposed school site, the school district is required to enter into a Voluntary Cleanup Agreement with DTSC to oversee a response action to be conducted by the district.^{61,62} DTSC would then certify all Response Actions completed, and notify the Division of the State Architect of any facility design condition.

Petroleum Program

Investigation and remediation work within the IR Program for those sites associated with petroleum hydrocarbon releases such as fuels and waste oils were conducted according to the Petroleum Program. The RWQCB is the lead agency for sites that fall under the Petroleum Program because petroleum hydrocarbons are not a CERCLA contaminant and also are exempt from DTSC’s State Superfund program.

California Department of Transportation – Hazardous Materials Transportation

Within California, the State agencies with primary responsibility for enforcing Federal and State regulations and for responding to transportation emergencies are the California Highway Patrol (“CHP”) and the California Department of Transportation (“Caltrans”). Together, Federal and State agencies determine driver-training requirements, load labeling procedures, and container

⁶¹ These DTSC responsibilities for school sites are separate from the CERCLA work being overseen by DTSC as part of the Navy’s work to clean up the former base.

⁶² For more information, see <http://www.dtsc.ca.gov/Schools/FAQ.cfm>.

specifications. Although special requirements apply to transporting hazardous materials, requirements for transporting hazardous waste are more stringent, and hazardous waste haulers must be licensed to transport hazardous waste on public roads.

California Division of Occupational Safety and Health – Worker Safety

Occupational safety standards exist in Federal and State laws to minimize worker safety risks from both physical and chemical hazards in the work place. The California Division of Occupational Safety and Health (“Cal OSHA”) and the Federal Occupational Safety and Health Administration are the agencies responsible for assuring worker safety in the workplace.

Cal OSHA assumes primary responsibility for developing and enforcing standards for safe workplaces and work practices; regulations specifically addressing protection of construction workers from exposure to hazardous substances are found in Title 8 of the California Code of Regulations. At sites known to be contaminated, a Site Safety Plan must be prepared to protect workers. The Site Safety Plan establishes policies and procedures to protect workers and the public from exposure to potential hazards at the contaminated site.

California Office of Emergency Services – Emergency Response, Business Plans, and Oversight of California’s Accidental Release Prevention Program

California has developed an emergency response plan to coordinate emergency services provided by Federal, State, and local government and private agencies. Responding to hazardous materials incidents is one part of this plan. The plan is administered by the State Office of Emergency Services (“OES”), which coordinates the responses of other agencies, including California EPA, CHP, the Department of Fish and Game, the RWQCB, and the local fire department. The San Francisco Fire Department provides first response capabilities, if needed, for hazardous materials emergencies within the Project Area.

OES is also the State administering agency for the California Accidental Release Prevention Program (“CalARP”) and California’s Hazardous Materials Release, Response and Inventory Law (“California’s Business Plan Law”). State and Federal laws require detailed planning to ensure that hazardous materials are properly handled, used, stored, and disposed of, and in the event that such materials are accidentally released, to prevent or to mitigate injury to human health or the environment. These laws require hazardous materials users to prepare written plans, such as Hazard Communication Plans and Hazardous Materials Management Plans. Laws and regulations require hazardous materials users to store these materials appropriately and to train employees to manage them safely. Primary responsibility for enforcement of these laws has

generally been delegated to local agencies, which for NSTI is the San Francisco Department of Public Health, Environmental Health Section.⁶³

Radiologic Health Branch

The Radiologic Health Branch is within the Food, Drug, and Radiation Safety Division of the California Department of Public Health. The Radiological Health Branch enforces the laws and regulations indicated below designed to protect the public, workers, and the environment from exposure to radiation. The Radiological Health Branch is responsible for providing public health functions associated with administering a radiation control program. This includes licensing of radioactive materials, inspection of facilities using radiation, investigation of radiation incidents, and surveillance of radioactive contamination in the environment.

The Radiological Health Branch administers and enforces the following laws and implementing regulations:

- Radiation Control Law (Health & Safety Code Sec. 114960 et seq.); and
- Regulations implementing the above laws are in Title 17, California Code of Regulations, Division 1, Chapter 5, Subchapters 4.0, 4.5, & 4.6.

Dredged Material Management Office

The Dredged Material Management Office (“DMMO”) facilitates the permitting process for dredging and dredged material disposal projects in the San Francisco Bay region. The DMMO consists of representatives from the EPA- Region 9, U.S. Army Corps of Engineers-San Francisco, San Francisco Bay RWQCB, the San Francisco Bay Conservation and Development Commission (“BCDC”), and the State Lands Commission. The DMMO serves as the single point of entry for applicants to the dredging and disposal permitting process. The facilitation of the dredging permitting process occurs within existing laws, regulations, and policies of the participating agencies. The DMMO processes permits for two types of dredging projects: (1) small dredging projects defined by a project depth of less than -12 feet MLLW and generating less than 50,000 cubic yards per year on average; and (2) other dredging projects defined by project depth greater than -12 feet MLLW or average annual volumes greater than 50,000 cubic yards.⁶⁴ Final decisions are made on the basis of consensus; if consensus is not possible the decisions are then referred to the Dredging Management Committee for resolution. The committee is made up of management executives from each of the DMMO member agencies.

⁶³ DTSC has no regulations regarding handling procedures during construction. This would be handled through the water quality requirements of a Stormwater Pollution Prevention Plan.

⁶⁴ USACE, Long Term Management Strategy For the Placement of Dredged Material in the San Francisco Bay Region. Management Plan 2001. *Prepared by USACE, USEPA, BCDC, and RWQCB*. A copy of this document is available for public review at the San Francisco Planning Department, 1650 Mission Street, Suite 400, in Case File No. 2007.0903E.

State (Structure and Building Components)

Asbestos

Section 19827.5 of the California Health and Safety Code, adopted January 1, 1991, requires that local agencies not issue demolition or alteration permits until an applicant has demonstrated compliance with notification requirements under applicable Federal regulations regarding hazardous air pollutants, including asbestos. The Bay Area Air Quality Management District (“BAAQMD”) is vested by the California legislature with authority to regulate airborne pollutants, including asbestos, through both inspection and law enforcement, and is to be notified ten days in advance of any proposed demolition or abatement work.

Notification includes the names and addresses of operations and persons responsible; description and location of the structure to be demolished/alterd including size, age and prior use, and the approximate amount of friable asbestos; scheduled starting and completion dates of demolition or abatement; nature of planned work and methods to be employed; procedures to be employed to meet BAAQMD requirements; and the name and location of the waste disposal site to be used. The BAAQMD randomly inspects asbestos removal operations. In addition, the BAAQMD will inspect any removal operation that receives a complaint.

Further, the local office of Cal OSHA must be notified before asbestos abatement is carried out. Asbestos abatement contractors must follow State regulations contained in 8CCR1529 and 8CCR341.6 through 341.14 where there is asbestos-related work involving 100 square feet or more of asbestos containing material. Asbestos removal contractors must be certified as such by the Contractors Licensing Board of the State of California.

The owner of the property where abatement is to occur must have a Hazardous Waste Generator Number assigned by and registered with the DTSC in Sacramento. The contractor and hauler of the asbestos-containing material are required to prepare a Hazardous Waste Manifest, which details the hauling of the asbestos containing material from the site to its disposal location. Pursuant to California law, the San Francisco Department of Building Inspection (“DBI”) would not issue the required permit until the applicant has complied with the notice requirements described above.

Polychlorinated Biphenyls

PCBs are organic oils that were formerly placed in many types of electrical equipment, including transformers and capacitors, primarily as electrical insulators. After years of widespread and commonplace installation, it was discovered that exposure to PCBs may cause various health effects, and that PCBs do not degrade easily and are highly persistent in the environment.

In 1979, the EPA banned the use of PCBs in most new electrical equipment and began a program to phase out certain existing PCB-containing equipment. The use and management of PCBs in electrical equipment is regulated pursuant to the Toxic Substances Control Act, 15 U.S.C. § 2601 *et seq.* (“TSCA”). TSCA and its implementing regulations generally require labeling and periodic inspection of certain types of PCB equipment and set forth detailed safeguards to be followed in the disposal of such items. TSCA also requires remediation of certain types of PCB spills to specified cleanup levels.

Lead and Lead-Based Paint

Pursuant to California Code of Regulations, Title 22 Section 66261.24, waste soil containing lead is classified as hazardous if the lead exceeds a total concentration of 1,000 parts per million (“ppm”) and a soluble concentration of 5 ppm. More discussion of lead-based paint regulations follows below in Local Plans and Policies.

Underground Storage Tanks

State laws governing USTs specify requirements for permitting, monitoring, closure, and cleanup. Regulations set forth construction and monitoring standards for existing tanks, release reporting requirements, and closure requirements. The Environmental Health Section of the San Francisco Department of Public Health is the local agency designated to permit and inspect USTs and to implement applicable regulations for investigation, closure, and remediation. The San Francisco Environmental Health Section Local Oversight Program and the San Francisco Fire Department have regulatory authority for removal of USTs. A closure plan for each UST to be removed must be prepared and submitted to the Fire Department prior to tank removal. The San Francisco Fire Department oversees the removal of USTs and the subsequent collection of subsurface soil samples beneath a removed UST, and any necessary remediation.

Local Plans and Policies

The *San Francisco General Plan* includes goals and policies that address public safety, including hazardous materials and fire safety. In general, the goals and policies provide support for the laws and regulations that are described above and below. The Community Safety Element and the Environmental Protection Element of the *San Francisco General Plan* contain the following policies relating to hazardous materials:

Community Safety Element

Policy 2.12: Enforce state and local codes that regulate the use, storage and transportation of hazardous materials in order to prevent, contain and effectively respond to accidental releases.

Environmental Protection Element

Objective 21: Control Illegal Disposal and Eliminate Land Disposal of Untreated Waste

Policy 21.1: Prevent illegal disposal.

Policy 21.2: Strengthen enforcement efforts.

San Francisco Department of Public Health Environmental Health Section

The Board of Supervisors adopted Article 22, Hazardous Waste Management, in the San Francisco Municipal Code to authorize the Director of the Department of Public Health, as the certified unified program agency approved pursuant to Chapter 6.11 of the Health and Safety Code, to implement and enforce the requirements of the California Hazardous Waste Control Act. The act is applicable to generators of hazardous waste and persons operating pursuant to a permit-by-rule, conditional authorization or conditional exemption set forth in Health and Safety Code Section 25404(c)(1).

The Director has the authority to certify unified program agencies by Health and Safety Code Section 25404(c)(1) to implement and enforce the provisions of the Hazardous Waste Control Act as set forth in California Health and Safety Code, Division 20, Chapter 6.5, and the minimum standards of management of hazardous waste as specified in Title 22 of the California Code of Regulations, Chapter 30, Division 4. The Director has the authority to carry out all duties imposed on certified unified program agencies with respect to regulation of hazardous waste, including, but not limited to, the following responsibilities:

- (1) Conduct inspections as provided for in Health and Safety Code Sections 25185 and 25185.5, of any factory, plant, construction site, waste disposal site, transfer station, establishment or any other place or environment where hazardous wastes are stored, handled, processed, disposed of, or being treated to recover resources;
- (2) Maintain records of compliance with the Hazardous Waste Control Act;
- (3) Require hazardous waste generators to pay inspection and administration fees to cover the Department's costs of administering the provisions of this Article. Such fees may include but shall not be limited to the cost of inspection, document development and processing, recordkeeping, enforcement activities, and informational materials development and distribution;
- (4) Issue authorizations for on-site treatment of hazardous waste to persons eligible to operate pursuant to permit-by-rule, conditional authorization or conditional exemption; and
- (5) Enforce against violations of the Hazardous Waste Control Act in accordance with Health and Safety Code, Division 20, Chapter 6.5, Article 8.

Throughout the City and County of San Francisco, a Hazardous Materials Management Plan must be prepared and submitted to the Department of Public Health by businesses that use or store certain quantities of hazardous materials. In addition, the San Francisco Environmental Health Section is the Unified Program Agency for the City and County of San Francisco providing

oversight of the following activities or substances conducted or handled by businesses within the County:

- Hazardous Waste Generators;
- Hazardous Waste Treatment;
- USTs;
- ASTs;
- Chlorofluorocarbon Recycling; and
- Medical Waste.

Lead-Based Paint

Work that could result in disturbance of lead paint must comply with Section 3407 of the San Francisco Building Code, Work Practices for Lead-Based Paint on Pre-1979 Buildings and Steel Structures. Section 3407 applies to the exterior of all buildings or steel structures on which original construction was completed prior to 1979 (which are assumed to have lead-based paint on their surfaces, unless demonstrated otherwise through laboratory analysis), and to the interior of residential buildings, hotels, and childcare centers. The ordinance contains performance standards, including establishment of containment barriers to protect human health and the environment as effectively as those required by HUD Guidelines (the most recent Guidelines for Evaluation and Control of Lead-Based Paint Hazards). Section 3407 also identifies practices that may not be used in disturbance or removal of lead-based paint. Any person performing work subject to Section 3407 shall, to the maximum extent possible, protect the ground from contamination during exterior work; protect floors and other horizontal surfaces from work debris during interior work; and make all reasonable efforts to prevent migration of lead paint contaminants beyond containment barriers during the course of the work. Clean-up standards require the removal of visible work debris, including the use of a High Efficiency Particulate Air Filter vacuum following interior work.

The ordinance also includes notification requirements and requirements for signs. Prior to the commencement of work, the responsible party must provide written notice to DBI that includes:

- The address and location of the project;
- The scope of work, including specific location;
- Methods and tools to be used;
- The approximate age of the structure;
- Anticipated job start and completion dates for the work;
- Whether the building is residential or nonresidential, and whether it is owner-occupied or rental property;

- The dates by which the responsible party has or will fulfill any tenant or adjacent property notification requirements; and
- The name, address, telephone number, and pager number of the party who will perform the work.

Further notice requirements include posting a sign when containment is required; posting a notice to occupants, including availability of a pamphlet related to protection from lead in the home; and providing notice of early commencement of work (if requested by occupant). Section 3407 contains provisions regarding inspection and sampling for compliance by DBI, and describes penalties for non-compliance with the requirements of the ordinance.

IMPACTS

Hazardous materials and hazardous wastes, if mishandled, could pose risks to human health and the environment. Potential health and safety impacts can stem from interactions of construction workers, the public and/or future occupants with hazardous materials and wastes encountered or generated during Proposed Project construction activities or operations.

SIGNIFICANCE CRITERIA

The City and County of San Francisco has not formally adopted significance standards for impacts related to hazards and hazardous materials. The Planning Department Initial Study Checklist form provides a framework of topics to be considered in evaluating potential impacts under CEQA. Implementation of a project could have potentially significant impacts related to hazards and hazardous materials if it were to:

- Create a significant hazard to the public or the environment through the routine transport, use, or disposal of hazardous materials;
- Create a significant hazard to the public or the environment through reasonably foreseeable upset and accident conditions involving the release of hazardous materials into the environment;
- Emit hazardous emissions or handle hazardous or acutely hazardous materials, substances, or waste within one-quarter mile of an existing or proposed school;
- Be located on a site, which is included on a list of hazardous materials sites compiled pursuant to Government Code Section 65962.5 and, as a result, create a significant hazard to the public or the environment;
- For a project located within an airport land use plan or, where such a plan has not been adopted, within two miles of a public airport or public use airport, result in a safety hazard for people residing or working in the project area;
- For a project within the vicinity of a private airstrip, result in a safety hazard for people residing or working in the project area;

- Impair implementation of or physically interfere with an adopted emergency response plan or emergency evacuation plan; or
- Expose people or structures to a significant risk of loss, injury or death involving fires.

APPROACH TO ANALYSIS

Property Transfer Background

Under the anticipated transfer terms between the Navy and TIDA, the Navy would satisfy all applicable statutory and regulatory requirements for any remaining remediation responsibilities and issue a FOST (exceptions noted below) prior to conveyance of the property. Sites will then be transferred in phases as FOSTs are issued. The Navy has acknowledged that it will remediate each site to the standards necessary to support the land uses that were identified in a previously prepared 1996 Reuse Plan (see also discussion in Chapter I, Introduction, p. I.4). While there are differences in the proposed land uses between the 1996 Reuse Plan and the Proposed Project, the Proposed Project includes far more proposed open space. However, the southeast portion of Treasure Island was proposed for publicly oriented uses in the 1996 Reuse Plan; this area is now being proposed for residential and mixed use. Regardless, the transfer documents issued will contain a complete disclosure of the type and quantity of hazardous substances that were present at the site, notice of the time at which such hazardous substance storage, release, or disposal took place, and a description of any remedial action taken.

At any time, however, the Navy and TIDA may enter into negotiations for an Early Transfer (or FOSET) for any individual parcel. A FOSET documents the remediation that has not been completed at the time of transfer and the protections to human health and the environment that will be implemented until all action necessary to protect human health and the environment have been taken. Under a FOSET, the Navy would not complete remediation prior to transfer and TIDA would assume responsibilities for obtaining site closure in accordance with federal and state requirements or that responsibility would remain with the Navy. In addition, the Navy and TIDA may also enter into a Lease in Furtherance of Conveyance (“LIFOC”) for any parcel, in which case the Navy would continue to retain responsibility for environmental remediation unless the Navy and TIDA were to agree otherwise, and the land would be leased from the Navy to TIDA until such time that a FOST was issued and land was suitable for transfer.

In addition to a FOSET, there are other circumstances where TIDA or TICD has responsibility for cleanup following transfer from the Navy:

- Areas where the proposed Development Plan is modified and land use controls on the property are inconsistent with the modified reuse.⁶⁵ For example, the FOST and

⁶⁵ For NSTI, many of the IR Sites are expected to be cleaned up to unrestricted use and land use controls will only be required in certain circumstances that involve any potential future earthwork activities which would require a soil management plan.

covenants to the deed may preclude reuse of the property for residential or other purposes. Specific remedial actions in addition to those performed by the Navy would be required prior to allowing those uses.

- Where the Proposed Project requires demolition or renovation of structures containing hazardous building materials such as lead-based paint or asbestos, additional response actions would be required. TIDA or TICD would be responsible for the remedial actions associated with any asbestos-containing materials or lead-based paint in accordance with applicable laws and regulations. This type of remedial action is expected as part of implementing the Development Program.
- Additional investigation / remedial actions may be required at parcels the Navy has remediated to a less stringent standard than that required for the proposed reuse. TIDA or TICD would be responsible for such remediation, since the need for it is triggered by the Proposed Project.
- Areas where newly discovered, pre-existing CERCLA and non-CERCLA contaminants (unknowns including unknown structures such as underground pipelines or USTs) are discovered and clean-up is necessary to allow for the proposed site reuse. During the course of construction activities, contamination might be newly discovered in areas or amounts not disclosed by prior environmental investigations and remedial activities conducted by the Navy. The protocols to address contaminants discovered during construction would be covered under a Soil and Groundwater Management Plan that would be developed by the project sponsors prior to the commencement of redevelopment activities.⁶⁶ If newly discovered, pre-existing contaminants are CERCLA hazardous substances, the Navy is obligated to perform the remedial work required to assure that the property is protective of human health and the environment.

Impact Analysis

This impact analysis focuses on whether the physical development of the Proposed Project could expose construction and maintenance workers, visitors, existing and future residents, employees, or ecological systems, to potential hazards associated with identified contaminants throughout the life of the Proposed Project. The evaluation was made in light of the Proposed Project plans, current conditions at the Development Plan Area, applicable regulations and guidelines, and previous environmental site assessments. Based on the Proposed Project and its geographical location, the Proposed Project would not result in impacts related to the following criteria and no impact discussion is provided for these topics for the following reasons:

- *Airport or Airstrip.* The Development Plan Area is not located within 2 miles of any airport or private airstrip and therefore no impact exists under this criterion.
- *Emergency Response Plan or Evacuation Plan.* The Proposed Project would result in an increase in the resident, employee and visitor populations in the Development Plan Area. The Proposed Project would alter the existing street network but all of the streets would meet the requirements of the San Francisco Fire Department (“SFFD”), SFPUC, San

⁶⁶ The Proposed Project includes preparing a Soil and Groundwater Management Plan (“SGMP”). To ensure that the SGMP is sufficient, Mitigation Measure M-HZ-1, discussed below, would require certain information and processes be included in the SGMP.

Francisco Department of Public Works (“SFDPW”) and the Municipal Transportation Agency (“MTA”). In some cases, particularly on Yerba Buena Island, private streets maintained by a homeowners’ association would not have the same requirements but would maintain accessibility to emergency services. In addition, the Proposed Project would add additional means of emergency access to the site with the construction of a ferry terminal and provision of ferry service by the San Francisco Water Emergency Authority. Although the Proposed Project would attract a larger population than is currently present at the site, the Proposed Project includes measures to provide adequate emergency support services (see Section IV.K, Utilities and Service Systems). Potential impacts related to emergency vehicle access are discussed in Section IV.E, Transportation, and Section IV.N, Geology and Soils. Potential impacts related to the provision of emergency police and fire (including hazmat) services to the Development Plan Area is discussed in Section IV.L, Public Services. The existing Emergency Response Plan for the City and County of San Francisco consists of a description of the City’s actions during a response to an emergency, the role of the Emergency Operations Center (EOC), and the coordination between the EOC and City departments and agencies. TIDA and the San Francisco Department of Emergency Management have prepared an Emergency Response Plan for events that may occur on Treasure Island and Yerba Buena Island. Overall, the Proposed Project would not impede the Emergency Response Plan, and would implement a transportation grid system that meets current standards for emergency response requirements. Additionally, the Proposed Project would not result in permanent road closures except temporary or partial closures during construction, and therefore, would not physically interfere with the existing Emergency Response Plan. There would be no impact related to interference or impedance to emergency response or evacuation plans.

- *Fires.* The Proposed Project is not located in, nor has the Project Area been designated as a wildland fire hazard area. The Project Area is surrounded by water, and the Proposed Project would implement a Habitat Management Plan that includes removing invasive species and establishing native habitats that would be less susceptible to fire. Emergency services, including a new fire station located on Treasure Island with appropriate staffing and equipment, to be constructed within the Development Plan Area,⁶⁷ would respond to fire emergencies on the Islands. In addition, all new construction would be designed and constructed in accordance with current Fire Safety Codes. Therefore, there would be no impact related to fires.

PROJECT IMPACTS

Construction Impacts

Impact HZ-1: Construction of the Proposed Project could expose construction workers to unacceptable levels of known or newly discovered hazardous materials as a result of disturbance of subsurface soils and/or groundwater with contaminants from historic uses. (*Less than Significant with Mitigation*)

⁶⁷ Jack Sylvan, Treasure Island Redevelopment Project Director, Mayor’s Office of Economic and Workforce Development, memorandum to Gary Massetani, Deputy Chief of Administration, San Francisco Fire Department, June 29, 2010. A copy of this document is available for public review at the San Francisco Planning Department, 1650 Mission Street, Suite 400, in Case File No. 2007.0903E.

As described in the “Setting” above, starting on p. IV.P.8, the proposed Development Plan Area has a long history of hazardous materials use. Past releases at various locations have resulted in contamination of soil and groundwater that has been the subject of numerous investigations as part of the Navy’s CERCLA and Petroleum Programs.⁶⁸ Environmental investigations and cleanup began in the mid-1980s and have continued to the present time. A base-wide investigation was conducted as part of the BRAC process, developed by the DoD for base closures, once the Treasure Island Naval Base ceased operations in 1997. As a result, these investigations have identified areas where the potential to cause risks to human health and the environment exists or where there is insufficient data available to make such a determination.

Since first identified for base closure, a substantial amount of work has been performed by the Navy regarding the identification and cleanup of subsurface contamination. A FOST has been completed for approximately 170 acres of the former naval base.⁶⁹ The anticipated transfer terms between the Navy and TIDA state that the Navy will continue to complete cleanup requirements and prepare a FOST for the remaining areas, including the IR sites that are still active prior to conveyance. If a FOST is not completed either a FOSET or LIFOC would be prepared for the site that would similarly disclose the history of investigations and remaining contamination, if any. The two parties are also cooperatively working to align the Navy’s cleanup schedule for the remaining remediation responsibilities with the proposed phasing of redevelopment activities. In general, the Proposed Project would not commence construction on any one parcel until a FOST, FOSET, or LIFOC has been completed for that area.⁷⁰ In some cases, the resultant FOST or ROD may require additional cleanup for any proposed land uses that vary from the 1996 Reuse Plan. In those limited instances, TIDA or TICD would assume responsibility for additional remediation actions as overseen by the responsible agency (likely the DTSC but also potentially the RWQCB) prior to redevelopment. TIDA or TICD may also assume responsibility for remediation for any parcels that are transferred under Early Transfer (also known as a FOSET). At this time, it is not known whether affected areas will be transferred to TIDA by means of a FOSET, or whether additional clean-up obligations will accompany such transfer. Regardless, any additional remediation required would be performed either by TICD or each parcel developer on behalf of TIDA under the oversight of the responsible agency, either DTSC or RWQCB.

However, as with any ground disturbing construction activities in areas such as the Development Plan Area, there is always a potential to encounter previously unidentified contamination. If

⁶⁸ As a result of these past releases, many of the sites in the Development Plan Area are considered to be listed among the hazardous waste site list pursuant to Government Code Section 65962.5 which is referenced in the significance criteria above.

⁶⁹ Arcadis, *Memorandum Summary of Proposed Remediation Approach*, April 19, 2010. A copy of this document is available for public review at the San Francisco Planning Department, 1650 Mission Street, Suite 400, in Case File No. 2007.0903E.

⁷⁰ It should be noted that there may be instances where infrastructure improvements could be made via a license to enter or an established easement where the contamination hazards are disclosed.

significant levels of hazardous materials in site soils are discovered, health and safety risks to workers could occur. Exposure to hazardous materials could cause various short-term and/or long-term health effects. Possible health effects could be acute (immediate, or of short-term severity), chronic (long-term, recurring, or resulting from repeated exposure), or both. Acute effects, often resulting from a single exposure, could result in a range of effects from minor to major, such as nausea, vomiting, headache, dizziness, or burns. Chronic exposure could result in systemic damage or damage to organs, such as the lungs, liver, or kidneys. Health effects would be specific to each hazardous material. In addition, contaminated soils and groundwater can present adverse effects to the environment including damage to the environment.

As stated above in “Regulatory Framework,” p. IV.P.30, Cal OSHA assumes primary responsibility for developing and enforcing standards for safe workplaces and work practices. At sites known to be contaminated, a Site Health and Safety Plan must be prepared to protect workers. With implementation of Mitigation Measure M-HZ-1, Soil and Groundwater Management Plan (“SGMP”), construction activities would require development of a SGMP that would contain worker safety requirements that must be included in a Site Health and Safety Plan prepared in accordance with Cal OSHA requirements for working at a site with contaminants that have been detected at Treasure Island. The SGMP would require evaluation of soil contamination data for existing soils prior to ground disturbance, if not already analyzed under the Navy program. If unexpected contaminated soils or unexpected USTs were encountered, protocols for appropriate disposal would be included in the SGMP. The SGMP would include notification and response protocols for any suspect soils or groundwater encountered during construction.

Therefore, with implementation of Mitigation Measures M-HZ-1: Soil and Groundwater Management Plan, in accordance with Cal OSHA requirements, construction activities would not expose construction workers to unacceptable levels of known hazardous materials and the potential impact would be reduced to less-than-significant levels.

Mitigation Measure M-HZ-1: Soil and Groundwater Management Plan

- Prior to issuance of a building or grading permit for any one or more parcels, the applicant shall demonstrate that its construction specifications include implementation of a Soil and Groundwater Management Plan (“SGMP”) prepared by a qualified environmental consulting firm and reviewed and agreed to by DTSC and RWQCB. For parcels transferred from the Navy under a Lease in Furtherance of Conveyance (LIFOC), or Early Transfer (FOSET) or parcels transferred under a FOST which specifies that additional remediation of petroleum contamination is necessary or additional remediation is necessary to meet the proposed land use, all additional or remaining remediation on those parcels shall be completed as directed by the responsible agency,

IV. Environmental Setting and Impacts

DTSC or RWQCB, prior to commencement of construction activities, unless (i) those construction activities are conducted in accordance with the requirements of any applicable land use covenant, lease restriction or deed restriction and in accordance with the Site Health and Safety requirements of the SGMP, or (ii) those construction activities are otherwise given written approval by either DTSC or RWQCB.

The SGMP shall be present on site at all times and readily available to site workers.

The SGMP shall specify protocols and requirements for excavation, stockpiling, and transport of soil and for disturbance of groundwater as well as a contingency plan to respond to the discovery of previously unknown areas of contamination (e.g., an underground storage tank unearthed during normal construction activities). Specifically, the SGMP shall include at least the following components:

1. Soil management requirements. Protocols for stockpiling, sampling, and transporting soil generated from on-site activities, and requirements for soil imported to the site for placement. The soil management requirements must include:
 - Soil stockpiling requirements such as placement of cover, application of moisture, erection of containment structures, and implementation of security measures. The soil stockpiling requirements must, at a minimum, meet the requirements of the San Francisco Dust Control Ordinance.
 - Protocols for assessing suitability of soil for on-site reuse through representative laboratory analysis of soils as approved by DTSC or RWQCB, taking into account the Treasure Island specific health-based remediation goals, other applicable health-based standards, and the proposed location, circumstances, and conditions for the intended soil reuse.
 - Requirements for offsite transportation and disposal of soil not determined to be suitable for on-site reuse. Any soil identified for off-site disposal must be packaged, handled, and transported in compliance with all applicable state, federal, and the disposal facility's requirements for waste handling, transportation and disposal.
 - Soil importation requirements for soil brought from offsite locations.
2. Groundwater management requirements. Protocols for conducting dewatering activities and sampling and analysis requirements for groundwater extracted during dewatering activities. The sampling and analysis requirements shall specify which groundwater contaminants must be analyzed or how they will be determined. The results of the groundwater sampling and analysis shall be used to determine which of the following reuse or disposal options is appropriate for such groundwater:
 - On-site reuse (e.g., as dust control);
 - Discharge under the general permit for stormwater discharge for construction sites;
 - Treatment (as necessary) before discharge to the sanitary sewer system under applicable San Francisco PUC waste discharge criteria;
 - Treatment (as necessary) before discharge under a site-specific NPDES permit;
 - Off-site transport to an approved offsite facility.

For each of the options listed, the SGMP shall specify the particular criteria or protocol that would be considered appropriate for reuse or disposal option. The thresholds used must, at a

minimum, be consistent with the applicable requirements of the RWQCB and the San Francisco Public Utilities Commission.

3. Unknown contaminant/hazard contingency plan. Procedures for implementing a contingency plan, including appropriate notification, site worker protections, and site control procedures, in the event unanticipated subsurface hazards or hazardous material releases are discovered during construction. Control procedures shall include:
 - Protocols for identifying potential contamination through visual or olfactory observation;
 - Protocols on what to do in the event an underground storage tank is encountered;
 - Emergency contact procedures;
 - Procedures for notifying regulatory agencies and other appropriate parties;
 - Site control and security procedures;
 - Sampling and analysis protocols; and
 - Interim removal work plan preparation and implementation procedures.

Impact HZ-2: Construction activities associated with the Proposed Project could expose the public, including existing and future residents as well as visitors and employees, to unacceptable levels of known or newly discovered hazardous materials as a result of disturbance of soil and/or groundwater with contaminants from historic uses. (*Less than Significant with Mitigation*)

The Proposed Project includes a phased approach to development across NSTI. Remediation activities will be ongoing in some areas for several years and occurring concurrently with the early phases of development. Therefore, both existing and future residents as well as other members of the public could become exposed to hazardous materials being disturbed through construction activities, either by inhalation of dust containing contaminants or by direct exposure to materials on construction sites, with health effects similar to those described for construction workers in Impact HZ-1.

For many sites, remediation will likely be completed prior to commencement of construction activities. As previously discussed, the remediation activities that are being undertaken by the Navy will occur without the Proposed Project. However, with implementation of Mitigation Measure M-HZ-1, a SGMP would be required for all construction activities at each proposed parcel. The SGMP would include all notification, site access protection (i.e. fencing, isolation of excavated soils, dust control, etc.), and other requirements that would protect the public from exposure to any known or newly discovered hazardous materials. For example, the SGMP would include dust monitoring systems with related dust control activities to minimize the migration of dust from the construction site. The handling, storage, and disposal requirements of any discovered contamination would include industry standard containment of contaminated soil or groundwater that would sufficiently protect any nearby residents, employees, or visitors. In

addition, the SGMP would include notification protocols for situations where suspected contamination is encountered that would involve, without limitation, either the DTSC or RWQCB or a local agency such as the San Francisco Fire Department Hazardous Materials Unit. Following notification, the contractor would be required to adhere to all requirements of the overseeing agency to protect the public from potential harmful exposure.

Mitigation Measure: Implement Mitigation Measure M-HZ-1.

Impact HZ-3: Construction of the Proposed Project could expose the environment to unacceptable levels of known or newly discovered hazardous materials as a result of disturbance of soil and/or groundwater with contaminants from historic uses. (*Less than Significant with Mitigation*)

Construction would include ground disturbing activities that could encounter known or newly discovered contamination. If not handled appropriately, these contaminated soils and/or groundwater could affect other areas of NSTI. Stockpiles of contaminated soils, if not given appropriate protection measures, could come in contact with stormwater runoff, resulting in contaminants infiltrating into groundwater or becoming entrained in surface flows and eventually discharged into San Francisco Bay, resulting in degraded water quality. If unidentified contaminated soils were reused on site, they could distribute contamination to other areas of NSTI.

Implementation of Mitigation Measure M-HZ-1 would require that all construction activities adhere to a SGMP prepared by the project sponsors and approved by DTSC or RWQCB. The SGMP would include detailed protocols for handling, testing, storage, and disposal protocols for all excavated soils and extracted groundwater. In addition, as also discussed in Section IV.O, Hydrology and Water Quality, the project sponsors and each parcel developer would be required to obtain coverage under the National Pollutant Discharge Elimination System (“NPDES”) General Construction Permit for Discharges of Stormwater Associated with Construction Activities (NPDES General Permit), under the RWQCB. Conditions of this permit would include adherence to mandatory best management practices (“BMPs”) as specified in a RWQCB approved stormwater pollution prevention plan (“SWPPP”) that include measures to provide protection of stockpiled soils. Therefore, implementation of the SGMP as required by Mitigation Measure M-HZ-1, as well as regulatory requirements of the NPDES General Permit, would result in a less-than-significant impact on the environment from construction activities.

Mitigation Measure: Implement Mitigation Measure M-HZ-1.

Impact HZ-4: Construction of the Proposed Project could expose construction workers, the public or the environment to unacceptable levels of hazardous materials as a result of dewatering activities that extract contaminated groundwater from historic uses. (*Less than Significant with Mitigation*)

Based on site conditions that include relatively shallow groundwater and on the proposed Development Plan, there is a strong likelihood that temporary dewatering would be required during construction activities. Trenching for installation of utilities as well as subgrade excavation for construction of foundations would require a lowering of the groundwater table to allow for construction beneath the water table, which is relatively shallow across Treasure Island. There is currently a substantial amount of data regarding the water quality across NSTI, and remediation efforts are underway or planned in numerous areas. In general, construction on a particular development parcel would only occur after remediation has been completed, including remediating groundwater where necessary.

With implementation of Mitigation Measure M-HZ-1, Soil and Groundwater Management Plan, the SGMP would require collection of groundwater data prior to dewatering. Any water extracted would be initially contained and analyzed for the constituents identified in previous investigations. If chemicals were found in groundwater, depending on the results of the sampling and agency approval, the groundwater could be reused for dust control, treated, discharged under a site-specific NPDES permit, discharged to the sanitary sewer system under permit from the San Francisco Public Utilities Commission, or removed and disposed of at an approved off-site facility. As also discussed in Section IV.O, Hydrology and Water Quality, compliance with the SGMP would ensure that water effluent from dewatering activities would meet applicable handling, storage and disposal requirements from RWQCB or SFPUC, and would therefore reduce the potential to expose to less-than-significant levels.

Mitigation Measure: Implement Mitigation Measure M-HZ-1.

Impact HZ-5: Construction activities associated with the Proposed Project could expose construction workers, the public or the environment to unacceptable levels of hazardous materials associated with encountering previously unidentified underground storage tanks. (*Less than Significant with Mitigation*).

Most of the USTs for the NSTI were installed in the 1940s, in an era when record keeping and regulations for USTs were much less stringent compared to current standards. The USTs have since been removed from service and the only active USTs for the base currently reside in Coast Guard property which is outside of the Redevelopment Project Plan Area. Given the history of UST use, however, there is a potential for discovery of previously unidentified USTs to be encountered during construction activities. If not prepared, workers could be exposed to hazardous materials or waste during excavation activities.

With appropriate training and contingency planning, suspect materials can be effectively isolated and handled in a manner that reduces the potential impacts to less than significant. As required by Mitigation Measure M-HZ-1, a Soil and Groundwater Management Plan would be implemented for all construction activities. The plan would include protocols for encountering previously unidentified USTs as well as any associated contamination if suspected. As also

required by the City and County of San Francisco, if previously unidentified USTs are encountered during construction, construction in the immediate area would cease until the UST is removed, with oversight from the San Francisco Fire Department Hazardous Materials Unit or other applicable oversight agency such as the RWQCB. If there is any indication that the tank has leaked, the RWQCB would be notified and provide direction regarding any appropriate remediation measures, if necessary. Removal of the UST would include, to the extent deemed necessary by the overseeing agency, over-excavation and disposal of any impacted soil that may be associated with such tanks. Implementation of Mitigation Measure M-HZ-1 and adherence to existing regulatory requirements would ensure that potential impacts related to discovering unanticipated USTs would be less than significant.

Mitigation Measure: Implement Mitigation Measure M-HZ-1.

Impact HZ-6: Dredging activities associated with the Proposed Project would not expose construction workers, the public or the environment to unacceptable levels of known or previously unidentified hazardous materials as a result of disturbance of submerged sediments. (*Less than Significant*)

The Proposed Project includes providing adequate water depth for the proposed ferry basin at the Ferry Terminal. In order for the ferry basin to accommodate the ferries, volumes of up to 32,000 cubic yards of sediments would require dredging and disposal.

There has been no previous analysis of potential contaminants in the area of the proposed ferry basin at the Ferry Terminal. Historical base operations do not indicate that this area was used for any waste disposal or other hazardous materials use. However, the potential exists that undocumented activities have resulted in contaminated sediments that could pose exposure risks to human health or the environment. For dredging activities proposed in association with the ferry basin, a handling and disposal location would be initially determined by the DMMO, which is the single point of entry for applicants to the dredging and disposal permitting process. DMMO permitting would require sampling and handling procedures that minimize potential risks to human health and the environment. Therefore, prior to any dredging activities, sediments targeted for removal would be sampled and analyzed according to the requirements of the agencies participating in the DMMO. Disposal could occur off site or the sediments could potentially be reused on site as fill material in a non-structural location (e.g., parks, open space, etc.) with regulatory agency approval.

Investigations for Clipper Cove (IR Site 27) indicate that lead shot is covered by as little as 1 foot of sediment in some near-shore locations. An FS report was finalized on August 13, 2010 which includes the latest sediment investigation results. As per the anticipated transfer terms between the Navy and TIDA, the Navy will complete site closure of IR Site 27 prior to transfer. The FOST for IR Site 27 would establish that the potential impact of previously identified lead shot contamination in sediments would be at less-than-significant levels. About 3,200 cubic yards of sediments is

proposed to be dredged at the eastern end of Clipper Cove, near Pier 1, for the Sailing Center launch facilities. This dredge area is outside of Site 27 and consequently outside of the area considered to have been impacted from lead shot fallout. Due to its location outside of Site 27, dredging for the Sailing Center launch facilities would not be expected to result in the release of lead shot and no significant impact is anticipated.

However, prior to dredging any materials, the project applicant would be required to retain a qualified environmental consulting firm to prepare a Sampling and Analysis Plan (“SAP”) as described and required by the U.S. Army Corps of Engineers (PN 99-4). The SAP would be submitted and approved by DMMO in accordance with regulatory requirements of each participating agency of DMMO and would include a proposal for a disposal location as well as a disposal alternatives analysis. Following agency approval of the SAP, sediment removal work would be conducted in accordance with all applicable OSHA and participating DMMO agency worker safety regulations. If hazardous waste is generated during this dredging operation, the handling, transport, and storage would be conducted consistent with all DMMO requirements which incorporate local, State, and Federal agency protocols.

With implementation of participating DMMO agency requirements, all dredging activities would occur according to a pre-approved SAP, which would reduce the potential impacts from dredging to less-than-significant levels.

Impact HZ-7: Disturbance and release of hazardous structural and building components (i.e. asbestos, lead, PCBs) during the demolition phase of the Proposed Project, or transportation of these materials could expose construction workers, the public, or the environment to adverse conditions related to hazardous materials handling. (*Less than Significant*)

As part of the base closure procedures, the Navy began evaluation of hazardous building materials in 1995. Several surveys were conducted to identify the presence of these hazards in existing structures; the surveys were intended to be used for disclosure upon transfer of property. Some of the accessible friable asbestos-containing materials (ACMs) identified during the surveys were remediated beginning in 1998.⁷¹ Under the anticipated transfer terms between the Navy and TIDA, the Navy will not do any further abatement of asbestos or lead-based paint. TIDA or TICD will be responsible for abatement of all remaining asbestos and lead-based paint within the Development Plan Area. Once the property is transferred, as part of the FOST, FOSET, or LIFOC, the Navy will include transfer documents that include notification of the survey results for ACMs and LBP.

⁷¹ *Final Summary of Environmental Conditions*, 2008.

Asbestos

The Navy remediated existing friable ACMs in a total of 58 buildings in 1998. However, according to the Supplemental Environmental Baseline Survey completed by the Navy in 2005, some additional remaining structures are known to still contain ACMs. Asbestos could be encountered during demolition of these existing buildings that would require containment and disposal. Affected buildings would need appropriate abatement of identified asbestos prior to demolition or renovation. ACMs are regulated both as a hazardous air pollutant under the Clean Air Act and as a potential worker safety hazard under the authority of Cal-OSHA. The renovation or demolition of buildings containing asbestos would require retaining contractors who are licensed to conduct asbestos abatement work and notifying the Bay Area Air Quality Management District (“BAAQMD”). Section 19827.5 of the California Health and Safety Code requires that local agencies not issue demolition or alteration permits until an applicant has demonstrated compliance with notification requirements under applicable Federal regulations regarding hazardous air pollutants, including asbestos.

The BAAQMD is vested by the California legislature with authority to regulate airborne pollutants, including asbestos, through both inspection and law enforcement, and is to be notified ten days in advance of any proposed demolition or abatement work.

Potential exposure to asbestos, and its related chronic adverse health effects, is possible throughout demolition and renovation if materials that contain asbestos are present during operations. However, abatement of known or suspected ACMs would occur prior to demolition or construction activities that would disturb those materials. Pursuant to an asbestos abatement plan developed by a State-certified asbestos consultant and approved by the City, all ACMs would be removed and appropriately disposed of by a State-certified asbestos contractor. Adherence to all the aforementioned regulatory requirements would ensure that potential impacts related to ACMs would be less than significant, and no mitigation is required.

Lead and Lead-based Paint

The surveys conducted by the Navy in 1998 for ACMs also included surveys for the presence of lead-based paint. Lead-based paint, if present, can be separated from building materials during the demolition activities. Separated paint can be classified as a hazardous waste if the lead content exceeds 1,000 parts per million and would need to be disposed of accordingly. Additionally, lead-based paint chips can pose a hazard to workers and adjacent sensitive land uses. Both the Federal and California OSHAs regulate all worker exposure during construction activities that disturb lead-based paint. The Interim Final Rule found in 29 CFR Part 1926.62 covers construction work where employees may be exposed to lead during such activities as demolition, removal, surface preparation for re-painting, renovation, clean up and routine maintenance. The OSHA-specified method of compliance includes respiratory protection,

protective clothing, good housekeeping practices, use of hygiene facilities, medical surveillance, training, and other measures. In addition, Section 3407 of the San Francisco Building Code would apply to demolition of all the structures within the Development Plan Area. The ordinance contains performance standards, including construction of containment barriers, protecting human health and the environment and identifies prohibited practices that may not be used in disturbances or removal of lead-based paint.

The existing regulatory framework requires that a lead-based paint abatement plan be prepared by a qualified consultant, which would include the following components:

- A pre-demolition lead-based paint survey for all structures proposed for demolition within the Development Plan Area. The survey would include sampling and identification of suspected materials containing lead-based paint.
- Development of an abatement specification plan that would be based on survey work and detail proposed abatement work areas and procedures.
- A site Health and Safety Plan.
- Containment of all abatement work areas to prohibit offsite migration of paint chip debris.
- Removal of all peeling and stratified lead-based paint on building surfaces and on non-building surfaces to the degree necessary to safely and properly complete demolition activities per the recommendations of the survey. The demolition contractor would be identified as responsible for properly containing and disposing of intact lead-based paint on all equipment to be cut and/or removed during the demolition.
- Appropriately remove paint chips by vacuum or other approved method.
- Collection, segregation, and profiling waste for disposal determination.

With implementation of an abatement plan and all the regulatory requirements regarding identification, handling, and disposal of LBP, the potential impacts related to demolition activities of lead-based paint materials would be reduced to less-than-significant levels. No mitigation is required.

PCB-Containing Materials

The Navy has sampled and assessed all known existing and former electrical equipment for PCBs on both Treasure Island and Yerba Buena Island. Results from the assessments conducted by the Navy identified areas where remediation and/or equipment removal was required. PCB remediation and removal work was completed and the work documented in a final PCB Summary Report dated January 2008.⁷² However, additional removal action was completed at Site 32 during the summer of 2009 and a closure report is forthcoming.⁷³ According to results of the PCB sampling program, there are still locations on Treasure Island where PCBs were found to be

⁷² *Final Summary of Environmental Conditions*, 2008.

⁷³ *Draft 2010 Site Management Plan, NSTI*.

above the criterion for low occupancy, and locations where PCBs were found to be above criteria for high occupancy but below criteria for low occupancy.⁷⁴ This work does not include remediation of any PCBs that were released to the subsurface (discussed above by IR Program Site and mitigated by Mitigation Measure M-HZ-1: Soil and Groundwater Management Plan).

Similar to the transfer terms regarding existing ACMs and lead-based paint, the Navy will provide all transfer documentation that discloses PCB sampling results. For the isolated locations where PCBs remain above either criteria for low or high occupancy, PCB abatement work from the electrical equipment would be conducted according to Federal and State standards. Therefore, the potential for PCBs in aboveground structures to impact Proposed Project activities has already largely been reduced, and adherence to regulatory requirements that are based on occupancy levels would reduce the potential impacts to less-than-significant levels. No mitigation is required.

Impact HZ-8: Hazardous materials used on site during construction activities (e.g. solvents) could be released to the environment through improper handling or storage. (*Less than Significant with Mitigation*)

Construction activities would require the use of certain hazardous materials such as fuels, oils, solvents, and glues. Inadvertent release of large quantities of these materials into the environment could adversely impact soil, surface waters, or groundwater quality. With implementation of Mitigation Measure M-HZ-8, Construction Best Management Practices, the potential impact from inadvertent releases during project construction activities would be less than significant.

Mitigation Measure M-HZ-8: Construction Best Management Practices

The use of construction best management practices (BMPs) shall be incorporated into the construction specifications and implemented as part of project construction. The BMPs would minimize potential negative effects to groundwater and soils and shall include the following:

- Follow manufacturer's recommendations on use, storage and disposal of chemical products used in construction;
- All refueling and maintenance activities shall occur at a dedicated area that is equipped with containment improvements and readily available spill control equipment and products. Overtopping construction equipment fuel gas tanks shall be avoided;
- During routine maintenance of construction equipment, properly contain and remove grease and oils; and

⁷⁴ The criterion for low occupancy was 25 mg/kg (ppm) and the criterion for high occupancy was 1 mg/kg (ppm). Tetra Tech, Inc., *Draft 2010 Site Management Plan, Naval Station Treasure Island, San Francisco CA*, April 19, 2010. EPA's PCB regulations define "high occupancy" as persons without dermal/respiratory protection occupying areas with PCB waste for an average of over 16.8 hours a week (for PCBs on non-porous surfaces) or for an average of over 6.7 hours per week (for bulk PCB waste); "low occupancy" is any such occupancy of shorter duration. 40 C.F.R. § 761.3.

- Properly dispose of discarded containers of fuels and other chemicals.

Impact HZ-9: Temporary dewatering activities during construction would not affect or alter groundwater flow directions that would bring contaminated groundwater toward areas outside of the Development Plan Area including the Job Corps campus. (*Less than Significant*)

Construction activities on Treasure Island would require temporary dewatering for the purpose of utility installation and for building construction where up to two levels of basements are planned. However, dewatering systems for shallow foundations and utility corridors would be relatively shorter in duration and less likely to affect groundwater flow patterns than dewatering for construction requiring deeper excavations.⁷⁵ Groundwater on Treasure Island is relatively shallow at approximately 4 to 10 feet below ground surface. There are two main areas in the vicinity of the Job Corps campus where groundwater is contaminated: IR Sites 21 and 24. Both of these sites are located along the southeastern and eastern edges of the island, which are relatively distant from the Job Corps campus. The Job Corps campus is located in the central part of Treasure Island, where groundwater is generally highest. As a result of this high point, groundwater flow generally is away from the Job Corps campus in all directions. Based on the hydrogeologic characteristics of the island and assumptions of dewatering requirements for similar construction projects, an estimated radius of influence of 300 feet has been calculated for the island.⁷⁶ Based on the proposed locations of deeper foundations, the radius of influence of the proposed dewatering would also not extend across the Job Corps site into the contaminated groundwater at IR Site 21 or Site 24. Therefore, temporary dewatering during construction would not alter flow of contaminated groundwater and the impact of dewatering would be less than significant. No mitigation is necessary.

Operations Impacts

Impact HZ-10: Migration of residual contamination could expose existing and future residents, employees, or the general public to hazardous materials causing acute or chronic health effects. (*Less than Significant with Mitigation*)

As has been discussed in the Setting and the impact analyses above, past releases at various locations within the former NSTI have resulted in contamination of soil and groundwater that has been the subject of numerous investigations as part of the Navy's CERCLA and Petroleum Programs. As part of the ongoing regulatory process for these sites, contamination of soil and groundwater will be remediated in accordance with DTSC and RWQCB requirements that assure each IR site is protective of human health and the environment, whether or not the Proposed

⁷⁵ Arcadis, *Potential Impacts of Temporary Construction Dewatering on the Migration of Volatile Organic Compound (VOC) Plumes, Former Naval Air Station Treasure Island, San Francisco, California* April 19, 2010. A copy of this document is available for public review at the San Francisco Planning Department, 1650 Mission Street, Suite 400, in Case File No. 2007.0903E.

⁷⁶ Ibid.

- Project is implemented. The IR site boundaries are defined by the limits of potential contamination identified during preliminary investigations. Closure of each IR site would be based on all the collected data, including a Risk Assessment that uses numerical risk values estimated for both carcinogenic and non-carcinogenic compounds. Often, the threshold of concern is based on a one-in-a-million (1×10^{-6}) cancer risk for a given land use. However, the EPA risk management range is one-in-ten-thousand to one-in-a-million, and a variety of thresholds within that range have been used at NSTI. The Risk Assessment also considers site specific conditions, including depth to groundwater, underlying soil characteristics, and proposed
- land uses. Site closure would not be approved by the overseeing regulatory agency unless the data clearly indicate that no significant risks to human health or the environment remain. The Navy would not recommend a site for transfer via a FOST unless the data clearly indicate that no significant risks to human health or the environment remain. In some cases, the ROD may contain land use controls that are implemented to protect human health and the environment against residual contamination that poses no threat provided the terms of the ROD remain in effect as required by law, for the duration of the life of the project. Therefore, with the continued remediation efforts currently being conducted by the Navy and any that would be assumed by TIDA as overseen by the DTSC or RWQCB, the potential for residual contamination to significantly impact residents, employees or the general public would be minimized. However, there could be residual contamination with volatile components, such as chlorinated solvents (for example, both PCE and TCE have been identified at Sites 21 and 24). With implementation of Mitigation Measure HZ-10, the potential impacts to future residents, visitors, or employees from these residual volatile contaminants would be reduced to less-than-significant levels.

Mitigation Measure M-HZ-10: Soil Vapor Barriers

- Prior to obtaining a building permit for an enclosed structure within IR Sites 21 or 24 or within any area where the FOST or site closure documentation specifies that vapor barriers are necessary or that additional sampling must be conducted to determine if vapor barriers are necessary due to the presence of residual contamination that has volatile components (such as chlorinated solvents PCE and TCE or certain petroleum hydrocarbons), the applicant shall demonstrate either that the building plans include DTSC-approved vapor barriers to be installed beneath the foundation for the prevention of soil vapor intrusion, or that DTSC has determined that installation of vapor barriers is not necessary.

**Impact HZ-11: Project operations would not result in a significant impact involving the handling of general commercial/retail and household hazardous waste.
(Less than Significant)**

The Proposed Project would redevelop the Development Plan Area into a mixed-use community with residential, commercial/retail, open space, and marina uses. Commercial/retail and building

IV. Environmental Setting and Impacts

support activities would use hazardous chemicals common in other commercial/retail and support settings. These chemicals would include familiar materials such as toners, paints, lubricants, kitchen and restroom cleaners, pesticides and other maintenance materials. These common consumer products would be used for the same purposes as in any commercial/retail or support setting. Small quantities of hazardous materials are also associated with residential land uses

including cleaning products, fuels, oils, pesticides and lubricants. Activities such as automobile or building maintenance, as well as landscaping, can become sources of releases of hazardous materials. Because general commercial/retail and household hazardous materials are typically handled and transported in small quantities, and because the health effects associated with them are generally not as serious as industrial uses, operation of the new uses in the Development Plan Area would not cause an adverse effect on the environment with respect to the use, storage, or disposal of general office and household hazardous materials generated. For commercial/retail uses, the regulatory framework requires appropriate training of employees in the use, storage and disposal of any hazardous materials and wastes. Therefore, with adherence to the existing regulatory requirements, the potential impact would be less than significant. No mitigation is necessary.

The Ferry Terminal would not be used for heavy maintenance or refueling of vessels, but could still be the source of accidental releases of hazardous materials such as fuels and oils during operations. The Proposed Project would ultimately employ the use of up to three ferry vessels under the Enhanced Transit Scenario, though initially one vessel would be used. Newer vessels are built in accordance with current standards and are not likely to release substantial quantities of hazardous materials that would pose a significant threat to human health or the environment. With regular maintenance of the new ferry vessel(s), it is reasonable to expect no substantial releases of hazardous materials in the reasonably foreseeable future. If existing vessels were leased for use at the Treasure Island Ferry Terminal, they would be required to be maintained in accordance with Coast Guard regulations to avoid releases of hazardous materials. The impact would be less than significant, and no mitigation is required. For further discussion of impacts on aquatic habitat, see Section IV.M, Biological Resources.

Impact HZ-12: The Proposed Project would include operation of a new or upgraded wastewater treatment plant. Water treatment chemicals would be necessary for standard operations and if not stored or handled appropriately could be released to the environment. (*Less than Significant*)

The proposed new or upgraded wastewater treatment plant (“treatment plant”) would require the storage and handling of water treatment chemicals as part of wastewater treatment operations. If accidentally released, these chemicals could cause human health effects to plant personnel and surrounding populations and could cause adverse environmental effects if released to the environment. However, the chemical storage and handling systems are stringently regulated by RCRA and locally enforced by DTSC. The facility would be designed and constructed in accordance with legal requirements for the safe storage of hazardous materials, including development and implementation of a hazardous materials management plan, which is regulated by the San Francisco Environmental Health Section. Requirements typically include, but are not limited to separation of incompatible materials with a noncombustible partition, spill control improvements in all storage, handling, and dispensing areas, and separate secondary containment

for each chemical storage system. Incorporation of these legally required design features would reduce the potential for spills resulting from the storage and handling of hazardous materials that would be used at the new or upgraded treatment plant. In addition, there is an existing treatment plant that uses similar quantities of hazardous materials that would not significantly change with the Proposed Project. With compliance with the legal requirements, potential impacts related to a release of chemicals from the new or upgraded treatment plant would be less than significant. See also the discussion of potential water quality impacts from the proposed new or upgraded treatment plant in Section IV.O, Hydrology and Water Quality. No mitigation would be required.

Impact HZ-13: The Proposed Project includes developing the existing school site into a K-8 school. The existing school is located in the vicinity of Site 12 where hazardous materials have been released to the subsurface. If not remediated appropriately, students, workers, or the public could be exposed to adverse conditions related to hazardous materials emissions. (*Less than Significant with Mitigation*)

The Development Plan Area currently contains a school that has been closed and would be renovated and reopened as a part of the Proposed Project. Under CEQA, a project would be considered to have a significant impact if it would emit hazardous emissions or handle hazardous or acutely hazardous materials, substances, or waste within one-quarter mile of an existing or proposed school. The school site on NSTI is located within a quarter-mile of Site 12. Site 12, which is discussed in Setting on p. IV.P.18, has already undergone substantial subsurface investigation, and an HHRA and an ecological risk assessment are planned for the site. From these documents, remediation goals and strategies would be developed under the oversight of DTSC to reduce potential threats to human health and the environment. The ultimate goal of this process is to obtain site closure where there is no threat to human health or the environment based on proposed future uses, such as a school use. However, due to the large size of Site 12 and extent of contamination, completion of remediation activities may extend over a long period of time. Remediation goals would be determined based on potential pathways of exposure and remaining concentrations of contaminants of concern. Remediation could occur on Site 12 without affecting occupants of the proposed school with a sufficient buffer. With implementation of Mitigation Measure M-HZ-13, the potential impact would be reduced to less-than-significant levels.

Mitigation Measure M-HZ-13: Human Health Risk Assessment

Prior to reopening the presently closed elementary school for elementary school use, TIDA or the SFUSD shall enter into a Voluntary Clean-Up Agreement (“VCA”) with DTSC's School Property Evaluation and Cleanup Division for the school site, regardless of whether any physical construction or expansion activities that trigger the requirement to consult with DTSC under the Education Code are proposed. As part of the VCA, a Preliminary Endangerment Assessment (“PEA”) shall be prepared under the supervision of DTSC's School Property Evaluation and

Cleanup Division. If the Preliminary Endangerment Assessment discloses the presence of a hazardous materials release, or threatened release, or the presence of naturally occurring hazardous materials, at or near the school site at concentrations that could pose a significant risk to children attending the school or adults working at the school, or discloses that ongoing or planned remediation activities to address such a release near the school could pose a significant risk to children attending the school or adults working at the school, then the school shall not reopen until all actions required by DTSC to reduce the increased cancer risk from exposure to such releases to less than one in a million (1×10^{-6}) and reduce the increased risk of noncancerous toxic effects such that the Hazard Index for chronic and acute hazards is less than one.

In the event DTSC declines to supervise the process required by this measure in circumstances where it is not required to do so under the California Education Code, the PEA shall be approved by the San Francisco Department of Public Health, applying the risk standards set forth above for cancer and non-cancer risks.

CUMULATIVE IMPACTS

Impact HZ-14: Development of the Proposed Project, when combined with other past, present, and foreseeable development in the vicinity, would not result in cumulative hazardous materials impacts. (*Cumulative Impact: Less than Significant*)

As discussed above, the Proposed Project would result in potentially significant project-level hazardous material impacts related to construction activities and the operation phase. Hazardous material impacts typically occur in a local or site-specific context versus a cumulative context combined with other development projects. The project development, with implementation of the identified mitigation measures, would have less-than-significant hazardous materials impacts on the public or the environment in the vicinity of the Project Area. The Islands are located in an isolated region in the center of the Bay; however, other foreseeable projects, including the proposed replacement of the existing on/off ramps from the Bay Bridge at the east side of Yerba Buena Island and the construction and operation of a 400-berth Marina in Clipper Cove, may have a similar potential to disturb existing contamination. The operation of the Marina would likely be associated with the handling of limited quantities of hazardous materials such as fuels. However, these projects would be required to comply with the same or similar regulatory framework as the Proposed Project. This includes federal and state regulatory requirements for transporting (California EPA and Caltrans) hazardous materials or cargo (including fuel and other materials used in all motor vehicles) on public roads or disposing of hazardous materials (California EPA, DTSC, San Francisco Department of Public Health). The demolition activities related to the construction of the proposed replacement ramps may encounter lead-based paint; however, these activities would be required to adhere to regulations similar to or the same as those required of the Proposed Project. Adherence to these regulations would minimize exposure

IV. Environmental Setting and Impacts
P. Hazards and Hazardous Materials

and ultimately result in removing hazardous materials from the region. Therefore, the cumulative effect of the project on hazardous materials, in combination with other foreseeable projects, would not be significant.

Q. MINERAL AND ENERGY RESOURCES

This section evaluates the Proposed Project's effects on mineral and energy resources. Impacts related to electricity and natural gas infrastructure are discussed in Section IV.K, Utilities and Service Systems. The relationship between energy consumption and greenhouse gas emissions is discussed in Section IV.G, Air Quality.

Q.1 MINERAL RESOURCES

SETTING

All land in the City and County of San Francisco, including the Project Area, is designated Mineral Resource Zone 4 ("MRZ-4") by the California Division of Mines and Geology under the Surface Mining and Reclamation Act of 1975.¹ This designation indicates that there is inadequate information available about the land for it to be assigned to another MRZ; thus, the area is not a designated area of significant mineral deposits. No locally important mineral resources are identified in the Project Area in the *San Francisco General Plan*.

Regulatory Framework

There are no regulations related to mineral resources applicable to the Project Area.

IMPACTS

Significance Criteria

The City and County of San Francisco has not formally adopted significance thresholds for impacts related to mineral resources. The Planning Department's Initial Study Checklist provides a framework of topics to be considered in evaluating potential impacts under CEQA.

Implementation of a project could have a significant impact related to mineral resources if it were to:

- Result in the loss of availability of a known mineral resource that would be of value to the region and the residents of the State; or
- Result in the loss of availability of a locally-important mineral resource recovery site delineated on a local general plan, specific plan or other land use plan.

¹ California Division of Mines and Geology, Open File Report 96-03, 1996 and Special Report 146 Parts I and II, 1986. Copies of these reports are available for public review at the San Francisco Planning Department, 1650 Mission Street, Suite 400, in Case File No. 2007.0903E.

Project Impacts

Treasure Island and Yerba Buena Island (“the Islands”) are already developed with existing institutional and residential buildings. There are no known mineral resources in the Development Plan Area. Development of the Proposed Project would not impact future evaluation of known mineral resources or designation of the site. Additionally, there are no designated mineral resource recovery sites in the Development Plan Area whose operations or accessibility would be affected by the construction or operation of the Proposed Project. Therefore, the Proposed Project would have no impact on known mineral resources or any locally-important mineral resources recovery site.

Q.2 ENERGY RESOURCES

SETTING

Existing Electrical Demand

Energy demand is measured by power flow, expressed in kilowatt-hours (kWh) on a residential utility bill and in megawatt-hours (i.e., million Watt hours, abbreviated MWh) when describing large-scale use, such as a city. Peak demand in California occurs on hot summer days when the cooling load is greatest; however, in the cool San Francisco Bay climate, peak demand may occur on a cold winter evening when the heating load is greatest (where electric heat is used). Peak demand is measured in capacity, expressed in megawatts (MW).

Recent data available from the California Energy Commission (“CEC”) indicate that California’s per capita electricity use is the lowest of any state.² In 2005, the per capita usage was about 12,000 kWh per person nationwide, while California’s usage per person was about 7,000 kWh. National consumption for the U.S. was about 3,661 million MWh annually, and for California, about 254 million MWh annually.

The estimated existing peak electrical-capacity demand for Treasure Island and Yerba Buena Island is approximately 3.1 MW.³ This figure includes the existing residential and commercial

² CEC web site, “U.S. Per Capita Electricity Use by State in 2005,” http://energyalmanac.ca.gov/electricity/us_per_capita_electricity_2005.html, accessed April 10, 2010.

³ *Treasure Island Infrastructure Plan Update*, Chapter 11, Addendum, August 18, 2009 (hereinafter referred to as *Infrastructure Update*), Section II.1.1. A copy of this document is available for public review at the San Francisco Planning Department, 1650 Mission Street, Suite 400, in Case File No. 2007.0903E. This value is based on recorded meter data for the period November 2004 to October 2005.

uses, wastewater treatment plant, Job Corps, and Coast Guard. The existing electric energy demand is roughly 15,000 MWh per year.⁴

Existing Electrical Supply

According to CEC data, 73 percent of California's electricity supply is generated in-state, while about 8 percent comes from the Northwest and 18 percent from the Southwest.⁵ In 2008, the primary resources used to generate California's electricity were approximately 46 percent natural gas, 16 percent coal, 15 percent nuclear, 10 percent large hydroelectric, and 14 percent renewables (wind, solar, etc.).⁶

San Francisco receives the majority (over 75 percent) of its electricity from Pacific Gas and Electric Company ("PG&E"). PG&E's resource mix is approximately 42 percent natural gas, 23 percent nuclear, 19 percent large hydroelectric, 13 percent renewables, and 3 percent coal.⁷ In 2008, PG&E's renewable energy (13 percent) consisted of about 5 percent biomass, 4 percent small hydroelectric, 2 percent geothermal, 2 percent wind, and close to 0 percent solar.⁸

The remainder of San Francisco's electricity is provided by the San Francisco Public Utilities Commission ("SFPUC") and other local generators. The SFPUC generates hydroelectric power at the Hetch Hetchy Water and Power project in and near Yosemite National Park, and at other locations in the Sierras. The SFPUC has three hydroelectric projects, capable of producing about 400 MW of electricity during the spring run-off period, when the associated water reservoirs are full.⁹ During an average year, the hydroelectric plants are capable of producing 1.7 million MWh.¹⁰ The SFPUC also purchases power.

The SFPUC provides electricity to the Islands. Within the SFPUC, the Power Enterprise focuses on providing adequate and reliable supplies of electric power to meet the municipal requirements

⁴ TICD, *A Sustainable Future for Treasure Island*, October 2006 (hereinafter referred to as *Treasure Island Sustainability Plan*), p. 44. A copy of this document is available for public review at the San Francisco Planning Department, 1650 Mission Street, Suite 400, in Case File No. 2007.0903E. This rough number is from a figure, "Energy Consumption (by Phase)," and was derived from an SFPUC metered data set for 1996-2006, using the final two years of the sequence.

⁵ CEC, Energy Almanac, "California's Major Sources of Energy," http://energyalmanac.ca.gov/overview/energy_sources.html, accessed April 10, 2010 (hereinafter referred to as "California's Major Sources of Energy"). These figures are preliminary data for 2008.

⁶ California's Major Sources of Energy.

⁷ CEC web site, "California Major Utilities' Resource Mix for 2006," http://energyalmanac.ca.gov/electricity/electricity_resource_mix_pie_charts/index.html, accessed April 10, 2010.

⁸ CEC web site, "California Major Utilities' Resource Mix for 2006," http://energyalmanac.ca.gov/electricity/electricity_resource_mix_pie_charts/index.html, accessed April 10, 2010.

⁹ SFPUC and San Francisco Department of Environment, *The Electricity Resource Plan: Choosing San Francisco's Energy Future* (Revised December 2002) (hereinafter referred to as "ERP"), pp. 21-22.

¹⁰ ERP, p. 22.

- of the City and County of San Francisco and the non-municipal requirements of Hunters Point Shipyard and Treasure Island/Yerba Buena Island.¹¹ The Redevelopment Project group within the Power Enterprise manages short-term utility services and long-term development of infrastructure improvements at Treasure Island and Yerba Buena Island.¹²

Existing Natural Gas Demand

Natural gas is measured in cubic feet of gas, or by its heat content in British Thermal Units (Btu) or therms.¹³ According to CEC data, in 2006, California consumed about 6,032 million cubic feet of natural gas per day. Total residential consumption was about 6,700 million therms in 2007, and average gas consumption per household was about 538 therms.¹⁴

The existing natural gas demand at the Islands, including the Job Corps campus and the Coast Guard, is roughly 1.5 million therms per year.¹⁵

Existing Natural Gas Supply

According to the CEC, in 2007 13 percent of California's natural gas needs were supplied by in-State sources, while about 41 percent came from the Southwest, 24 percent from the Rocky Mountain area, and 22 percent from Canada.¹⁶ PG&E provides natural gas to San Francisco and the Islands.

Because of its low density, natural gas is difficult to store.¹⁷ After extraction from the earth, natural gas is transported over long distances by pipeline from sources to demand centers. Only a relatively small portion is stored in facilities or underground. Gas is typically supplied on-demand and California's reliance on imported natural gas leaves the state vulnerable to price shocks and supply disruptions.

¹¹ SFPUC web site, http://sfwater.org/mc_main.cfm/MC_ID/12, accessed April 10, 2010.

¹² SFPUC web site, http://sfwater.org/mto_main.cfm/MC_ID/12/MSD_ID/138/MTO_ID/241, accessed April 10, 2010.

¹³ A British Thermal Unit is the amount of heat needed to raise the temperature of one pound of water (approximately 8.3 gallons) one degree Fahrenheit. A therm is a unit of measurement for natural gas, equivalent to 100,000 Btu's.

¹⁴ CEC Energy Almanac web site, "Overview of Natural Gas in California," <http://energyalmanac.ca.gov/naturalgas/overview.html>, accessed on April 10, 2010.

¹⁵ *Treasure Island Sustainability Plan*, p. 45. This rough number is from a figure, "Natural Gas (Consumption by Phase)," and was derived from a SFPUC metered data set for 1996-2006, using 2004-2006 data.

¹⁶ California's Major Sources of Energy.

¹⁷ Liquefying natural gas by greatly reducing its temperature greatly reduces the storage volume needed, but this process is expensive.

Regulatory Framework

Section IV.H, Greenhouse Gas Emissions, “Regulatory Framework,” extensively discusses Federal, State, and local rules and policies intended to decrease emissions of greenhouse gases. Many of those rules are intended to reduce energy use and to encourage switching from fossil fuels to renewable sources. The regulatory framework regarding electric and natural gas infrastructure is discussed in Section IV.K, Utilities and Service Systems, “Electric and Natural Gas Infrastructure,” pp. IV.K.2 – IV.K.5.

Federal, State, and local laws, regulations, policies govern and influence supply and demand for energy, as described below.

Federal

The Energy Independence and Security Act of 2007 is the latest major, comprehensive, energy legislation at the Federal level. It includes a renewable fuel standard (Section 202), appliance and lighting efficiency standards (Sections 301-325), and building energy efficiency standards (Sections 411-441).

The American Recovery and Reinvestment Act of 2009 (H.R. 1, also known as the “Stimulus Bill”) included a number of provisions to encourage the development and financing of renewable energy, from demonstration project funding to loan guarantees.

State

The California Code of Regulations, Title 24, parts 1 and 6 (referred to below as “Title 24”) regulates energy efficiency in buildings. Title 24 provides construction standards for heating, cooling, ventilation, water heating, and lighting.¹⁸ The CEC regulates appliance efficiency and has adopted progressively more stringent regulations over the years, most recently in 2009.¹⁹

In July 2008, the California Building Standards Commission adopted voluntary green building standards that will become mandatory in the 2010 California Building Code, which will become effective January 1, 2011.²⁰ The California Green Building Standards Code establishes standards including planning and design for sustainable site development, energy efficiency in excess of the

¹⁸ These regulations are contained in CEC, *2008 Building Energy Efficiency Standards for Residential and Nonresidential Buildings*, effective January 1, 2010, CEC-400-2008-001-CMF, December 2008, California Energy Commission web site, “2008 Building Energy Efficiency Standards,” <http://www.energy.ca.gov/title24/2008standards/index.html>, accessed April 10, 2010.

¹⁹ CEC, 2009 Appliance Efficiency Regulations, CEC-400-2009-013, August 2009, California Energy Commission web site, “California’s Appliance Efficiency Program,” <http://www.energy.ca.gov/appliances/index.html>, accessed April 10, 2010.

²⁰ These voluntary standards became effective August 1, 2009. California Building Standards Commission web site, http://www.documents.dgs.ca.gov/bsc/2009/PR09-01_Aug_2009.pdf, accessed April 10, 2010.

California Energy Code requirements, and other matters. The Green Building Standards Code allows local jurisdictions that had already adopted green building standards to retain them if they are as, or more, stringent than the provisions in the state code.

California has a Renewable Portfolio Standard (“RPS”) that requires retail sellers of electricity to procure 20 percent of their resources from renewable sources by the year 2010.²¹ In addition, sellers must increase their percentage of renewable power by 1 percent per year. The law applies to both investor-owned and publicly owned utilities. Thus far, utilities in the State are not on track to achieve the 20 percent goal in 2010, but, will generally fall several percentage points short. The California Public Utilities Commission (“CPUC”) expects the investor-owned utilities will achieve the 20 percent renewable target by 2013 or 2014.²² For example, in 2008, PG&E served 11.9 percent of its retail electricity sales with renewable power.²³ SFPUC obtains a majority of its electricity from Hetch Hetchy hydroelectric sources, which are renewable resources (although only hydroelectric facilities smaller than 30 MW are included within the Renewable Portfolio Standard's definition of “renewable”²⁴).

Governor Schwarzenegger signed Executive Order S-14-08 on November 17, 2008, which raises California’s RPS to 33 percent by the year 2020.²⁵ The Governor’s Executive Order S-21-09, signed September 15, 2009, requires the California Air Resources Board to establish regulations by July 2010 towards achieving the 33 percent goal.²⁶

The CPUC regulates investor-owned utilities operating in California, including Pacific Gas & Electric Company. The CPUC has required utilities to conduct energy efficiency (or “demand-side management”) programs for many years, including, for example, subsidies for installing weatherization in residential buildings. The CPUC also has extensive programs to implement the RPS and otherwise encourage renewable energy.

²¹ The RPS was established by Senate Bill 1078 in 2002, and Senate Bill 107 in 2006 moved the original 2017 deadline to 2010.

²² CPUC, Renewables Portfolio Standard Quarterly Report Q4 2009, p. 4, <http://www.cpuc.ca.gov/NR/rdonlyres/52BFA25E-0D2E-48C0-950C-9C82BFEEF54C/0/FourthQuarter2009RPSLegislativeReportFINAL.pdf>, accessed on April 10, 2010.

²³ CPUC web site, “California Renewables Portfolio Standard (RPS),” <http://www.cpuc.ca.gov/PUC/energy/Renewables/index.htm>, accessed April 10, 2010.

²⁴ California Public Resources Code § 25741(b)(1); see also California Energy Commission, “Hydroelectric Power in California,” available at <http://www.energy.ca.gov/hydroelectric/index.html>, accessed October 27, 2010.

²⁵ Executive Order S-14-08 s, <http://gov.ca.gov/executive-order/11072>, accessed April 10, 2010.

²⁶ Executive Order S-21-09 s, <http://gov.ca.gov/executive-order/13269>, accessed April 10, 2010.

Local

San Francisco General Plan

The Environmental Protection Element²⁷ of the *San Francisco General Plan* contains a section on energy. The following objectives and policies are relevant to the Proposed Project:

²⁷ The Environmental Protection Element, http://www.sfgov.org/site/planning_index.asp?id=41417, accessed April 10, 2010.

Environmental Protection Element

- Objective 12: Establish the City and County of San Francisco as a Model for Energy Management.
- Policy 12.1: Incorporate energy management practices into building, facility, and fleet maintenance and operations.
 - Policy 12.3: Investigate and implement techniques to reduce municipal energy requirements.
 - Policy 12.4: Encourage investment in capital projects that will increase municipal energy production in an environmentally responsible manner.
 - Policy 12.5: Include energy emergency preparedness plans in municipal operations.
- Objective 13: Enhance the Energy Efficiency of Housing in San Francisco.
- Policy 13.2: Strengthen enforcement of the state's residential energy conservation building standards.
 - Policy 13.3: Expand the environmental review process to encourage the use of additional measures to save energy in new housing.
 - Policy 13.4: Encourage the use of energy conserving appliances and lighting systems.
- Objective 14: Promote Effective Energy Management Practices to Maintain the Economic Vitality of Commerce and Industry.
- Policy 14.2: Insure adequate local enforcement of California's non-residential building standards.
 - Policy 14.3: Commercial case studies and energy research efforts should be undertaken to determine cost-effective energy conservation strategies, e.g. single metering, integrated energy systems, flextime to reduce peak transit use, that should be integrated into EIR procedures.
 - Policy 14.4: Promote commercial office building design appropriate for local climate conditions.
 - Policy 14.5: Encourage use of integrated energy systems.
- Objective 15: Increase the Energy Efficiency of Transportation and Encourage Land Use Patterns and Methods of Transportation Which Use Less Energy.
- Policy 15.1: Increase the use of transportation alternatives to the automobile.
 - Policy 15.3: Encourage an urban design pattern that will minimize travel requirements among working, shopping, recreation, school and childcare areas.
 - Policy 15.5: Encourage consideration of energy use issues when making transportation investment decisions.
- Objective 16: Promote the Use of Renewable Energy Sources.
- Policy 16.1: Develop land use policies that will encourage the use of renewable energy sources.

The Housing Element of the *San Francisco General Plan* provides the following objective and policy:

Objective 11: In Increasing the Supply of Housing, Pursue Place Making and Neighborhood Building Principles and Practices to Maintain San Francisco's Desirable Urban Fabric and Enhance Livability in All Neighborhoods.

Policy 11.10: Include energy efficient features in new residential development and encourage weatherization in existing housing to reduce overall housing costs and the long-range cost of maintenance.

Other San Francisco Plans and Policies

The City has several other plans that aim to reduce energy use and/or encourage renewable sources of energy. The City developed a Sustainability Plan²⁸ as official policy in 1997, but the Board of Supervisors has not yet committed the City to perform all of the actions addressed in the plan. The Sustainability Plan provides general policy direction towards achieving energy efficiency, greater use of renewables, and reducing pollution (see discussion in Chapter III, Plans and Policies).

In 2002, San Francisco adopted an Electricity Resource Plan that focused on replacement of old power plants in the southeast portion of the City.²⁹ The plan focuses on reliable, affordable, and renewable sources of energy for the future of San Francisco. A subsequent study, published in 2003, *An Energy Resource Investment Strategy*, further analyzed the City's energy situation, and described actions to take for energy efficiency and renewable energy.³⁰ San Francisco subsequently adopted a *Climate Action Plan* (2004) committing the City to reducing greenhouse gas emissions by 20 percent below 1990 levels by 2012.

In 2004, the City amended Chapter 7 of the Environment Code, requiring all new municipal construction and major renovation projects to achieve Leadership in Energy and Environmental Design ("LEED"®) Silver Certification. According to the U.S. Green Building Council, which developed LEED, LEED provides building owners and operators with a framework for identifying and implementing green building design, construction, operations and maintenance

²⁸ San Francisco Department of Environment, Sustainability Plan web pages, <http://www.sfenvironment.org/downloads/library/sustainabilityplan.pdf>, and linked PDF files, accessed April 10, 2010.

²⁹ *ERP*, pp. 1-6.

³⁰ Rocky Mountain Institute, *An Energy Resource Investment Strategy (ERIS) for the City and County of San Francisco*, Final Report December 2003, pp. 5-17, http://sfwater.org/detail.cfm/mc_id/138/mto_id/239/c-id/1346, accessed April 10, 2010.

solutions.³¹ LEED uses colors to designate increasing energy efficiency, from “Certified” to “Silver” to “Gold” to “Platinum.”

In 2008, San Francisco adopted a Green Building Ordinance that increases the stringency of energy saving requirements for new construction of residential and commercial buildings and renovations to existing buildings. The Green Building Ordinance requires an unprecedented level of LEED and green building certifications,³² which makes San Francisco’s ordinance one of the most stringent green building requirements in the nation. Under the ordinance, by 2012, new commercial buildings over 25, 000 sq. ft. must meet LEED Gold requirements. Residential buildings taller than 75 feet must meet LEED Silver, and smaller residential structures must earn 75 points on the GreenPoints checklist. GreenPoints refers to a residential green building system and checklist and certification methodology of the non-profit organization Build It Green.³³

IMPACTS

Significance Criteria

The City and County of San Francisco has not formally adopted significance thresholds for impacts related to energy resources. The Planning Department’s Initial Study Checklist Form provides a framework of topics to be considered in evaluating potential impacts under CEQA. Implementation of a project could have a potentially significant impact related to energy resources if it were to:

- Encourage activities which result in the use of large amounts of fuel, water, or energy, or use these in a wasteful manner.

Approach to Analysis

A number of factors may be considered in determining whether a project would use a large amount of energy or whether the use of energy would be wasteful, such as: 1) the degree to which energy conservation measures would be applied, 2) use of on-site renewable energy, and 3) conformance with policies geared to energy efficiency.³⁴

³¹ U.S. Green Building Council (USGBC) web site, <http://www.usgbc.org/DisplayPage.aspx?CMSPageID=1988>, accessed April 10, 2010.

³² San Francisco Building Inspection Commission Codes, Building Code 2007 Edition, Chapter 13C, Green Building Requirements, added September 4, 2008 by Ordinance No. 180-08 (hereinafter referred to as *San Francisco Green Building Requirements*), http://www.sfenvironment.org/downloads/library/sf_green_building_ordinance_2008.pdf, accessed on April 9, 2010.

³³ *San Francisco Green Building Requirements*, section 1302C.

³⁴ *State CEQA Guidelines*, Appendix F, “Energy Conservation,” provides a list of optional factors that an EIR may consider in analyzing the energy implications of a project.

For the Proposed Project, electrical and natural gas demand estimates were created using an energy modeling software program called eQUEST,³⁵ as further described below under “Proposed Project’s Electricity and Natural Gas Demand.”

Treasure Island Sustainability Plan

The *Sustainability Plan* for Treasure Island sets forth the project sponsors’ initial sustainable development ideas and commitments. The *Sustainability Plan* aims to reduce energy demand and promote renewable energy as follows:³⁶

Goal: Reduce energy demand, create sustainable supply, and achieve carbon neutrality.

Strategy E1. Minimize peak energy demand and reduce overall energy consumption of buildings and infrastructure.

Strategy E2. Centralize heating and cooling where appropriate to maximize efficiency and reliability.

Strategy E3. Maximize the percentage of on-island power generation from renewable sources.

Strategy E4. Encourage and utilize renewable power generation from off-site sources.

Strategy E5. Provide adequate supplemental on-island power generation capacity or an alternative supply to support operation of the island following loss of supply.

Strategy E6. Support carbon neutrality by minimizing emissions.

Proposed Project Facilities

The following discussion is based on preliminary concepts for the Proposed Project’s electricity, natural gas and renewable energy systems.³⁷ Most of the electric power that would be used on the Islands would continue to be generated off site. This power would continue to be transmitted to the Islands, and distributed by, a local utility provider. In addition, TIDA would direct the provision of on-site renewable energy. All heating and cooling would provided at the individual building level and independent from the adjacent buildings (see Chapter VI, Project Variants, Variants A.2 and A.3, for a discussion of possible district heating and cooling variants under consideration). The Proposed Project would meet Title 24 energy conservation measures, and meet or exceed the standards in San Francisco’s Green Building Ordinance.

³⁵ Arup North America Ltd., *Treasure Island Development Energy Study*, prepared for TICD, December 2009, p. 9 (hereinafter referred to as *2009 Energy Study*). A copy of this document is available for public review at the San Francisco Planning Department, 1650 Mission Street, Suite 400, in Case File No. 2007.0903E.

³⁶ *Treasure Island Sustainability Plan*, p. 39.

³⁷ As discussed in Chapter II, Project Description, master utility plans for the electrical and gas system service will be prepared in coordination with the SFPUC. These plans will include detailed layouts and design requirements for the on- and off-site upgrades and repairs, coordination with utilities providers, and phasing plans for the new systems.

Renewable Energy

The *Infrastructure Plan* includes a renewable energy component involving photovoltaic solar power and possibly small, vertical-axis wind turbines. The project sponsors have committed to meeting 5 percent of peak electric demand with on-site renewable sources, such as (but not limited to) solar photovoltaic.³⁸ This target would be achieved by designing building rooftops to accommodate photovoltaic systems, and potentially using solar water heating and demonstration-level wind energy production. No particular target has been established for renewable energy to take the place of natural gas use, but if technologies such as solar hot water would be used, then some displacement of natural gas use for heating would occur.

The draft *Design for Development* would permit development of either ground-mounted or roof-mounted photovoltaic systems. With current technology, about 1.4 to 3 acres of photovoltaic panels³⁹ (either ground or roof-mounted) would be required to meet the goal of 5 percent of the peak power demand.⁴⁰ The draft *Design for Development* would permit roof-mounted photovoltaic systems on all buildings, including on historic Buildings 1, 2, and 3.

Two photovoltaic (PV) technologies would likely be used at Treasure Island: crystalline silicon (c-Si) PV and thin-film PV.⁴¹ The technology is manufactured in arrays of cells containing the material that converts solar radiation into direct current electricity. The material is typically encased in glass, but new technologies are being developed that would include solar PV systems as part of a building's outer covering. The direct current PV output would be converted to alternating current for input to the electric grid.

Roof-mounted photovoltaic systems typically look like large, dark, glass panels. On a flat roof, the panels may be set up at an angle to better catch the sun's rays. Panels in ground-mounted PV systems may lie flat on the ground, be set up at an angle, or have other configurations. For example, the panels may be attached to poles that turn to track the sun during the day.

The types of wind power systems are not known. Changes in technology are expected over the next few years that make it difficult to accurately predict the precise nature of the equipment likely to be used. Therefore, wind energy production facilities and locations are expected to be selected at some time in the future and would undergo appropriate environmental review at that time.

³⁸ *Infrastructure Update*.

³⁹ Based on information from Arup, the Project Sponsors' energy consultant.

⁴⁰ The peak photovoltaic output would not coincide with the Proposed Project's peak demand. The photovoltaic peak output would occur around 1 p.m. on a July day. The Proposed Project's peak electric demand would likely occur around 6 p.m. on a September day. *2009 Energy Study*, p. 4.

⁴¹ *2009 Energy Study*, p. 24.

Energy Conservation

The Proposed Project would meet Title 24 energy conservation measures, meet the standards of San Francisco's Green Building Ordinance, and could include additional energy conservation measures such as those listed below:⁴²

- Insulation at higher levels than required;
- High-performance windows (glazing), such as additional panes of glass, low emissivity coating on one of the glass panes, or a reflective or tinted coating;
- External shading of a building;
- Daylighting (allowing natural light into a building to reduce lighting needs), including skylights;
- Thermal mass (typically meaning interiors with exposed concrete with no painting or other finishes);
- Occupancy sensors to turn off lights when rooms are unoccupied;
- High efficiency lighting (such as compact fluorescent bulbs or LEDs);
- Natural ventilation;
- Natural ventilation with baseboard heating (where heat is distributed via water to radiator type emitters that sit below windows at exterior walls);
- Split system air conditioning for residential units, having high cooling efficiency;
- Split system heating systems;
- Heat pump cooling systems;
- Radiant heating and cooling (meaning running hot or chilled water through tubes embedded in the floor);
- Underfloor air distribution (putting air into rooms at low elevations rather than high elevations under more pressure);
- Demand control ventilation (sensing the level of carbon dioxide to reduce unnecessary ventilation);
- Waterside economizer (an extra hydronic circuit to allow a building's heat rejection system to bypass the chiller, reducing chiller use);
- Indirect evaporative cooling;
- Heat recovery systems;
- High efficiency chillers and boilers;
- Variable speed drives on motors;
- Energy Star-compliant equipment (including appliances); and
- Solar hot water systems.

⁴² 2009 Energy Study, pp. 13-16.

The next subsection explains the net energy reduction associated with using the measures and provides further details on meeting San Francisco's energy conservation requirements.

Proposed Project's Electricity and Natural Gas Demand

The *Treasure Island Development Energy Study* discussed below estimates the likely peak and annual energy demand for the Proposed Project using reasonable assumptions of what would be expected to be built given regulatory requirements, the Treasure Island Green Building Specifications, and typical construction practices in the Bay Area. Based on these estimates, the Proposed Project's electrical peak demand is estimated at 11.4 MW and annual electrical energy consumption at 58,500 MWh.⁴³ The Proposed Project's peak natural gas demand is estimated at 42.6 million British Thermal Units per hour (Btu/hr) and annual gas consumption at 980,000 therms per year.⁴⁴ Total annual, operational, energy consumption would be 297,500 million Btu/yr. These estimates assume various strategies for energy demand reduction using reasonable assumptions of what would be expected to be built, given regulatory requirements, Treasure Island Green Building Specifications, and typical construction practices in the Bay Area.

These estimates assume that four levels of energy demand reduction are implemented:

- Implementing the energy conservation measures required by Title 24,
- Meeting the San Francisco Green Building Ordinance or LEED-New Construction Gold energy performance equivalent,
- Adding energy conservation measures in accordance with the Treasure Island Green Building Specifications,
- Assuming no space cooling would be provided for low-rise and medium-rise residential buildings and assuming gas-fired baseboard heating (rather than heat pumps) would be used for these residential buildings.

These estimates are for full build-out and include the infrastructure that would be installed (e.g., new or upgraded wastewater treatment plant) as well as the existing uses that would remain.

The following text explores the assumptions underlying these estimates. The project sponsors' engineering consultant, Arup North America Ltd. ("Arup"), developed the estimates for building energy consumption using an energy modeling software program called eQUEST.⁴⁵ The engineers created computer models of seven different generic building types, and made assumptions regarding their energy efficiency.⁴⁶

⁴³ *2009 Energy Study*, p. 1.

⁴⁴ *2009 Energy Study*, page following p. 23 (Treasure Island Energy Iteration Comparison).

⁴⁵ *2009 Energy Study*, p. 9.

⁴⁶ *2009 Energy Study*, pp. 9-10.

Level 1, the base case, assumes compliance with Title 24 energy efficiency standards in effect in 2008 (as would be required for new buildings permitted in 2010).⁴⁷ Under the base case, electrical peak demand would be 18.3 MW, annual electrical energy demand 78,000 MWh, and total annual energy consumption, 350,000 million Btu/yr.⁴⁸ To help set clear targets for building energy conservation that would exceed State and local energy regulations, Arup performed calculations for three increasingly stringent levels of energy conservation measures.⁴⁹

Level 2 applies San Francisco's Green Building Ordinance or the Treasure Island Green Building Standards, and assumes that commercial and residential buildings would meet an equivalent to LEED New Construction Gold certification.⁵⁰ Under the ordinance, by 2012, new commercial buildings over 25,000 sq. ft. must meet LEED Gold requirements. Residential buildings taller than 75 feet must meet LEED Silver, and smaller residential structures must earn 75 points on the Greenpoints checklist.⁵¹ Implementing these energy performance measures would result in approximately 9 percent less energy use than when simply complying with Title 24.

Level 3 improves upon Level 2 by applying a series of additional energy conservation measures that would be consistent with the Treasure Island Green Building Specifications, and which are described above. Level 3 would reduce overall energy consumption by another 6 percent over Level 2 (i.e., approximately 15 percent less energy use than when simply complying with Title 24).⁵²

Level 4 incorporates the climatic conditions at the Islands into the Level 3 assumptions. Cooling is typically not necessary in low- to medium-sized buildings near the San Francisco Bay because there are few really hot days, and internal building loads (e.g., from lighting) are not that great in smaller buildings. Level 4 assumes that no cooling equipment for new low- to medium-sized residential buildings would be provided. Further, Arup assumed gas-fired baseboard heating for these residential buildings, rather than its base-case assumption of electrical heat pumps.⁵³

Implementation of Level 4 would result in considerable energy conservation beyond that required by California Title 24 standards. Electricity peak demand for the Proposed Project under Level 4 would be 38 percent less than the base case; electricity energy consumption would be 25 percent

⁴⁷ *2009 Energy Study*, pp. 10-11.

⁴⁸ *2009 Energy Study*, p. 1.

⁴⁹ *2009 Energy Study*, pp. 2-3.

⁵⁰ *2009 Energy Study*, p. 11. "LEED NC is green building standards for new construction and major renovation.

⁵¹ *2009 Energy Study*.

⁵² *2009 Energy Study*, p. 4, Table 3.

⁵³ *2009 Energy Study*, p. 3.

less, and overall energy consumption would be 15 percent less than the base case.⁵⁴ Level 4 is the scenario recommended by Arup for the Proposed Project.

Project Impacts

Construction

Impact ME-1: Construction activities associated with the Proposed Project would not result in the use of large amounts of energy, or use energy in a wasteful manner. (*Less than Significant*)

Construction activities would require electricity to operate air compressors, hand tools, mobile project offices, and lighting. Construction vehicles and equipment would primarily use diesel fuel, and construction workers would use gasoline and diesel to commute. The construction activities would not be expected to result in demand for electricity or fuels greater than that for any other similarly-sized project in the region. Although the Proposed Project would be large, it would be constructed over a period of approximately 20 years, and demand for electricity and fuels would be spread out over these years. Given these considerations, the construction-related energy use associated with the Proposed Project would not be large or wasteful and would be less than significant. Therefore, no mitigation is required.

Operation

Impact ME-2: During operation, the Proposed Project would not result in the use of large amounts of energy, or use energy in a wasteful manner. (*Less than Significant*)

The Proposed Project's energy demand would not be expected to result in demand for electricity or natural gas greater than that for any other similarly sized project in the region. It would include energy efficiency measures beyond current requirements. As explained above, the Proposed Project would comply with Title 24 and meet or exceed the energy conservation requirements of San Francisco's Green Building Ordinance. The Proposed Project would also go beyond these two requirements by incorporating additional energy conservation measures through project-specific Green Building Specifications. Additional information is in the Sustainability Plan described above and summarized in Chapter II, Project Description. The proposed level of energy efficiency would ensure that the Proposed Project would not use energy in a wasteful manner.

To provide perspective regarding the Proposed Project's forecasted energy use, here are comparisons with demand within the PG&E service area. The Proposed Project's peak electrical capacity demand would be 11.4 MW. PG&E's forecasted peak coincident electrical demand for

⁵⁴ 2009 Energy Study, p. 4.

2012 is 19,126 MW.⁵⁵ The Proposed Project's peak would be 0.006 percent of the 2012 forecasted peak capacity demand for PG&E's service area.

The Proposed Project's annual electrical energy consumption at buildout would be 58,500 MWh/yr. PG&E's forecasted energy demand for 2012 is 90,789 Gigawatt-hours (GWh), equivalent to 90,789,000 MWh/yr.⁵⁶ The Proposed Project's energy would be 0.006 percent of the 2012 forecast for PG&E's service area.⁵⁷

The Proposed Project's annual natural gas consumption at build-out would be 98 million cu.ft./yr.⁵⁸ PG&E's natural gas demand for 2004 was 732,920 million cu. ft./yr.^{59,60} The Proposed Project's natural gas demand would be 0.003 percent of the 2004 usage in PG&E's service area.

The above comparisons show that the Proposed Project's energy demands would be very small compared to overall demand in the PG&E service area. The Proposed Project would not be expected to have a substantial effect on local and regional energy supplies, nor on the ability to serve peak energy demands. Furthermore, the Proposed Project would include a number of aspects to reduce its energy demand and would use renewable energy to offset a portion of its energy consumption, as discussed below.

The Proposed Project would be consistent with the energy efficiency objectives and policies in the *Environmental Protection Element* of the *General Plan* discussed under "Regulatory Framework" above. The Proposed Project would incorporate energy efficiency measures in municipal facilities (Objective 12) and in housing (Objective 13). It would be consistent with Policy 11.10 of the *Housing Element* for energy efficiency in housing.

The Proposed Project would produce 5 percent of peak power demand from on-site renewable resources, potentially including photovoltaic power generation and other renewable energy

⁵⁵ California Energy Commission web page regarding Pacific Gas & Electric Co., PG&E's Electricity Resource Planning Form S-1, dated 3/26/2009, http://energyalmanac.ca.gov/electricity/S-1_supply_forms_2009/, accessed June 12, 2010.

⁵⁶ California Energy Commission web page regarding Pacific Gas & Electric Co., PG&E's Electricity Resource Planning Form S-2, dated 3/26/2009, http://energyalmanac.ca.gov/electricity/S-2_supply_forms_2009/, accessed June 12, 2010.

⁵⁷ Note that the comparisons above regarding electrical use are for the Proposed Project's total demand, not the incremental increase over current demand from Treasure Island and Yerba Buena Island. Therefore, the comparisons are conservative.

⁵⁸ $980,000 \text{ therms/yr} \times \text{approximately } 100 \text{ cu.ft. gas/therm} = 98,000,000 \text{ cu.ft./yr.} = 98 \text{ million cu.ft./yr.}$

⁵⁹ PG&E data for 2004: $2,008 \text{ million cu. ft. gas/day} \times 365 \text{ days/yr.} = 732,920 \text{ million cu. ft. /yr.}$ A forecast for natural gas consumption was not available on the CEC web site.

⁶⁰ California Energy Commission, table called "PG&E Service Area Historical Gas Demand," "Historical natural gas demand 1990-2005 (Excel file)" <http://energyalmanac.ca.gov/naturalgas/index.html>, accessed June 12, 2010.

technologies. This is consistent with Objective 16 of the *Environmental Protection Element* encouraging the use of renewable energy.

In addition, as discussed in Chapter II, Project Description, pp. II.77 – II.79, the Proposed Project is designed compactly and with transportation features that encourage energy efficiency. This is consistent with Objective 15 of the *Environmental Protection Element*.

The Proposed Project would encourage recycling of solid waste, and would be required to comply with City ordinances that mandate reducing solid waste, as described in Section IV.K.5, Solid Waste Disposal. Reducing solid waste saves energy in the off-hauling of the waste. Recycling may save energy because less “virgin” raw materials are needed to make new products.

The Proposed Project would incorporate wastewater recycling. This would reduce the demand for potable water. Reducing potable water demand would save energy used to transport and treat, fresh water delivered to Treasure Island and Yerba Buena Island.

For these reasons, the operation-related energy use of the Proposed Project would not result in the use of large amounts of energy, or use the energy in a wasteful manner, and is therefore considered a less than significant impact.

Cumulative Impacts

Based on the Proposed Project’s (1) incorporation of measures that go beyond compliance with State and local energy efficiency laws, (2) inclusion of on-site renewable energy, and (3) conformance with State and local energy goals and policies, the Proposed Project’s contribution to overall energy consumption in California would not be cumulatively considerable.

R. AGRICULTURAL RESOURCES AND FOREST LAND

SETTING

Treasure Island and Yerba Buena Island are two contiguous islands in San Francisco Bay. Treasure Island has about 110 acres of residential buildings, 90 acres of open space, 95 acres of parking and roads, and 37 acres occupied by the Jobs Corps campus. The remaining 70 acres on Treasure Island are occupied by former institutional, retail, office, and industrial uses.¹ Landscaping is dominated by water-intensive grass lawns, planted medians, and a variety of trees, including Monterey pine, Canary Island palms, acacia, and olive trees. The historic buildings on Treasure Island and the Jobs Corps buildings are surrounded by parking lots and parks. Yerba Buena Island has a U.S. Coast Guard Station and Sector Facility (about 48 acres) and a portion of the San Francisco-Oakland Bay Bridge (about 18 acres). The remaining approximately 94 acres on Yerba Buena Island were part of the Naval Station Treasure Island. The island has 97 residential units and several historic buildings. Currently, there are no agricultural uses on the Islands, aside from small backyard gardens and the informal harvesting of olives from the trees on Treasure Island to produce olive oil for personal use.² There are no farms, grazing land, aquaculture, or other agricultural uses on the Islands. There is no forest land on Treasure Island.³ Certain existing trees on Yerba Buena Island may qualify as forest land. Neither of the Islands contains timberland.⁴

REGULATORY FRAMEWORK

Local

The *San Francisco General Plan* contains no specific mention of Treasure Island or Yerba Buena Island and does not discuss agricultural resources or forest lands that might be present. However, the topic of agriculture is discussed in the following objective in the *General Plan's* Recreation and Open Space Element:

Objective 1: Preserve large areas of open space sufficient to meet the long-range needs of the bay region.

¹ Total existing acres on Treasure Island equals approximately 404 acres. Totals cited are rounded, except for the Job Corps site.

² Robert Selena, "World's Fair Olive Trees Still Thriving," *San Francisco Chronicle*, April 13, 2009.

³ Section 12220(g) of the State Public Resources Code defines forest land as "land that can support 10 percent native tree cover of any species, including hardwoods, under natural conditions, and that allows for management of one or more forest resources, including timber, aesthetics, fish and wildlife, biodiversity, water quality, recreation, and other public benefits."

⁴ Section 4526 of the State Public Resources Code defines timberland as "land, other than land owned by the federal government and land designated . . . as experimental forest land, which is available for, and capable of, growing a crop of trees of any commercial species used to produce lumber and other forest products, including Christmas trees."

The Bay Area has developed to the point where an extensive regional open space system is needed. Such a system should preserve undeveloped or predominantly undeveloped land or water area which has value for 1) conservation of land and other natural resources, 2) recreation and park land, 3) historic or scenic purposes, 4) controlling the location and form of urban development, and 5) agriculture.

The San Francisco zoning maps do not include the geographic locations of Treasure Island or Yerba Buena Island. The Project Area is designated P (Public) under Planning Code Section 105(e), which designates any properties owned by the United States Government and not shown on the Zoning Maps as P (Public Use).

IMPACTS

SIGNIFICANCE CRITERIA

The City and County of San Francisco has not formally adopted significance thresholds for impacts related to agricultural resources or forest land. The Planning Department Initial Study Checklist form provides a framework for topics to be considered in evaluating potential impacts under CEQA. Implementation of a project could have a potentially significant impact related to agricultural resources or forest land if it were to:

- Convert Prime Farmland, Unique Farmland, or Farmland of Statewide Importance, as shown on the maps prepared pursuant to the Farmland Mapping and Monitoring Program of the California Resources Agency, to non-agricultural use;
- Conflict with existing zoning for, or cause rezoning of, forest land (as defined in Public Resources Code Section 12220(g)), timberland (as defined by Public Resources Code Section 4526), or timberland zoned Timberland Production (as defined by Government Code 51104(g));
- Result in the loss of forest land or conversion of forest land to non-forest use;
- Conflict with the existing zoning for agricultural use or a Williamson Act contract; or
- Involve other changes in the existing environment which, due to their location or nature, could result in conversion of Farmland of Statewide Importance to non-agricultural use or conversion of forest land to non-forest use.

PROJECT IMPACTS

Impact AG-1: The Proposed Project would not convert designated farmland under the Farmland Mapping and Monitoring Program, nor would it conflict with any existing agricultural zoning or a Williamson Act contract, nor would it involve any changes to the environment that would result in the conversion of designated farmland. (No Impact)

The California Department of Conservation, Division of Land Resource Protection, maps important farmland, including Prime Farmland, Farmland of Statewide Importance, Unique

Farmland, Farmland of Local Importance, and Grazing Land. Agricultural land is rated according to soil quality and irrigation status; the best quality land is called Prime Farmland. The California Department of Conservation's Farmland Mapping and Monitoring Program identifies the mainland of the City and County of San Francisco as "Urban and Built-up," and considers San Francisco in its entirety, including Treasure Island and Yerba Buena Island, to be outside of its agricultural survey area.⁵

Because the Project Area does not contain designated farmland, the Proposed Project would not convert Prime Farmland, Farmland of Statewide Importance, or Unique Farmland to a non-agricultural use.

The Proposed Project would not conflict with any agricultural zoning, because the existing zoning P (Public Use) District is not for agricultural use. Nor would the Proposed Project conflict with a Williamson Act contract, because there are no Williamson Act contracts for land within the City and County of San Francisco, including Yerba Buena Island and Treasure Island. While there are olive trees on Treasure Island whose olives are harvested to make olive oil, this is not a substantial agricultural enterprise, nor is the land on which the trees stand zoned for agricultural use or designated for farmland. Thus, the removal of the olive trees would not be a significant agricultural impact.

The Proposed Project would create an Urban Agricultural Park of up to 20 acres, in approximately the center of Treasure Island, northeast of the Job Corps site and southwest of the proposed Sports Park. The Urban Agricultural Park would be irrigated with recycled water, and green waste generated on the Islands would be composted and used as a soil amendment for plantings in the park. The park could be used to provide high-quality plantings and locally grown food, and would afford opportunities for agricultural-related training and employment, local business development, and educational programs for the residents and schools.

In conclusion, the Proposed Project would have no significant impacts on farmland and land zoned or contracted for agricultural uses. Therefore, no mitigation measures are required.

Impact AG-2: The Proposed Project would not conflict with existing zoning for, or cause rezoning of, forest land, timberlands, or timberland zoned as Timberland Production, nor would it result in the loss of or conversion of forest land to non-forest uses. (*Less than Significant*)

Neither Treasure Island nor Yerba Buena Island contain any timberland (as defined by Public Resources Code Section 4526), or timberland zoned Timberland Production (as defined by Government Code 51104g).

⁵ Patrick Hennessy, Farmland Mapping and Monitoring Program, telephone conversation, October 19, 2009.

IV. Environmental Setting and Impacts.
R. Agricultural Resources and Forest Land

Although the existing trees on Yerba Buena Island may constitute a forest pursuant to the Public Resources Code Section 12220(g) definition of “forest land,” the Proposed Project would not result in the loss of this forest land, or the conversion of forest land to non-forest use. The current development footprint on Yerba Buena Island would not change substantially with the Proposed Project and would not result in the loss of any potential forest land. Thus, there would not be any significant impacts to forest land, and no mitigation is required.

The Proposed Project would implement a Habitat Management Plan, discussed in Section IV.M, Biological Resources, which would improve and expand native species habitat on Yerba Buena Island. The Habitat Management Plan would include a forest management plan for the phased reduction of existing eucalyptus trees on Yerba Buena Island. This management strategy would be implemented to restore and enhance existing native oak woodland habitat, and would not be considered a significant impact on forest land. As such, no mitigation is required.

V. OTHER CEQA CONSIDERATIONS

A. GROWTH INDUCING IMPACTS

As required by Section 15126.2(d) of the *CEQA Guidelines*, an EIR must discuss the ways in which the Proposed Project could directly or indirectly foster economic or population growth, or the construction of additional housing, either directly or indirectly, in the surrounding environment. Growth-inducing impacts can result from the elimination of obstacles to growth; through increased stimulation of economic activity that would, in turn, generate increased employment or demand for housing and public services; or as a result of policies or measures which encourage premature or unplanned growth.

Implementation of the Proposed Project would require amendments to the *San Francisco General Plan* and the Planning Code. The existing zoning on Treasure Island and Yerba Buena Island is P (Public Use) District, and the existing height and bulk classification is 40-X. The Proposed Project would require that the *General Plan* and Planning Code be amended to incorporate the land use designations, height limits, and allowable land uses specified in the Area Plan and SUD, which incorporates the proposed *Design for Development*. These amendments and the resulting Development Program would change the mix and types of land uses on Treasure Island and Yerba Buena Island, and would allow for increased density and building heights. The ABAG regional *Projections 2009* includes proposed development within the Project Area as a Priority Development Area, and designates Treasure Island as an opportunity site for high-density housing and support services in the region. Improved and expanded infrastructure, public services, and transit improvements would be required to serve development on the Islands; however, the improved and/or expanded infrastructure and services would not create additional capacity beyond what is required to serve the Project Area, and therefore would not directly or indirectly induce growth in the region.

While the Proposed Project in itself represents growth, the provision of new housing and employment opportunities would not encourage substantial new growth in the City that has not previously been projected. As described in Section IV.C, Population and Housing, the Proposed Project would provide up to 7,195 net new housing units, including affordable and family-sized units. Using conservative assumptions, the Proposed Project would generate demand for 2,095 housing units in the region by 2030, which is far less than the 7,195 net new units proposed. As such, the Proposed Project would not be expected to generate the need for substantial new housing within the City, and would not contribute to unplanned housing growth in the region.

Development within the Project Area would provide about 2,600 net new permanent jobs by 2030. This total represents less than about 1 percent of the projected Citywide employment in 2030 and about 0.2 percent of the expected increase in projected regional

employment through 2030. Therefore, the Proposed Project would not contribute to unplanned employment growth that has not already been accounted for in the City and Bay Area region.

Implementation of the Proposed Project would replace aging and deteriorated infrastructure within the Development Plan Area. It would also create a new street grid and improved local and regional transit service that would improve access to the Islands. However, the Proposed Project would not create new transportation access to an area that was previously inaccessible by transit or automobile, and therefore would not create new access to an outlying area.

Proposed new construction and expansion, replacement or upgrade of the utility and infrastructure system, public roads, public facilities, and other community services and open space would not generate indirect population growth since those systems and services would primarily serve residents, employees, and visitors to the Project Area. The Islands are isolated by the Bay from other mainland development, and the Proposed Project would not extend water, sewer, or other public services to currently underserved mainland areas. Therefore, the Proposed Project would not eliminate obstacles to growth. Increased ferry transit access to the Islands could generate indirect population growth to the extent that it increases the attractiveness of the Development Plan Area for new employment or stimulates new housing development that would be accessible by the proposed ferry service.

The proposed *Sustainability Plan* includes a number of elements that would potentially limit indirect and unplanned growth. These include high-density, mixed-use development near transit and within walking distance of neighborhood services and open space (i.e., transit-oriented development), adaptive reuse of existing historic structures that allow for community services to be provided within existing building space instead of creating demand at other off-site locations, and transportation strategies such as parking capacity controls and congestion pricing that discourage sprawled development.

The Proposed Project would provide for high-density (100 to 110 units/acre) residential growth supported by community facilities, public services, transit service and infrastructure, and new or upgraded public utilities. To the extent that this growth would have been otherwise accommodated at other Bay Area locations, the Proposed Project could limit sprawl and support sustainable growth by providing an opportunity for infill development on underused land, near existing regional employment centers, housing and existing and planned transit facilities.

The Proposed Project would assist in meeting ABAG's regional housing objectives under the FOCUS Program and would conform with ABAG's regional goals to focus growth and development by creating compact communities with a diversity of housing, jobs, activities and services, and increasing housing supply, improving housing affordability, and increasing

transportation efficiency and choices.¹ In this respect, implementation of the Proposed Project may be considered growth managing rather than growth inducing by facilitating urban in-fill, restoring a previously developed site with sources of contamination, and increasing open space. Based on this analysis, the Proposed Project would not have a growth-inducing impact, and no mitigation is required.

- The America's Cup sailing races are expected to be held in San Francisco Bay in the summer and fall in 2012 and again in the summer and fall in 2013. No special facilities for these races are proposed to be constructed on Treasure Island or Yerba Buena Island. It is expected that interested spectators would use Treasure Island as a viewing area for some of these races, as would many other shoreline locations in San Francisco, such as Herb Caen Way along The Embarcadero, the Marina Green, and shoreline sites in the Golden Gate National Recreation Area.
- The spectator activities likely to occur on Treasure Island would be short term, similar to the special events that occur there now, such as the annual Treasure Island Music Festival. For those events, a special transportation demand management ("TDM") program is used to coordinate access to and egress from the Islands. Therefore, a mechanism is already in place to address any temporary transportation issues that might arise during the six- to eight-week period that the America's Cup races would occur. It is not likely that regular ferry service would have been initiated by the time that the America's Cup races were held; therefore, the existing TDM program would likely be used.
- Based on the information about phasing of the Proposed Project (see Chapter II, Project Description, Section K, Project Phasing and Construction, p. II.79 – II.82), it is not likely that substantial amounts of new housing or commercial space would have been constructed and be available for occupancy by 2012 – 2013 when the America's Cup races would occur. Therefore, it is not expected that spectator activities would result in substantial impacts on new businesses or new residents of the Islands. Spectator activity at Treasure Island during the America's Cup races would not be a long term or permanent activity. Therefore, it would not result in growth-inducing impacts on Treasure Island.

¹ ABAG administers the FOCUS program, in partnerships with MTC, BCDC, and BAAQMD. FOCUS is a regional development and conservation strategy that promotes more compact land use patterns in the Bay Area.

- There is likely to be new development on the mainland along the San Francisco waterfront to support the America's Cup. Specifics of that development are currently being developed, and environmental review of that development has been initiated by the San Francisco Planning Department.² It is possible that some of the temporary waterfront development for the race activities would block pedestrian views of Treasure Island and Yerba Buena Island from The Embarcadero and Herb Caen Way. Impacts will be identified in detail in the EIR that is now in preparation for that project. Permanent improvements to Piers 30-32, 26 and 28, 19 and 19-1/2, and 27-29 and 29-1/2 have not been designed in detail. The improvements known at this time mainly include seismic upgrades and repairs and improving the pier structures and aprons. These and other improvements along the mainland shoreline would not directly affect Treasure Island or Yerba Buena Island.

B. SIGNIFICANT UNAVOIDABLE IMPACTS

In accordance with Section 21061 of CEQA and with Sections 15126(b) and 15126.2(b) of the *CEQA Guidelines*, the purpose of this section is to identify significant environmental impacts that cannot not be eliminated or reduced to less-than-significant levels by implementation of mitigation measures included in the Proposed Project or identified in Chapter IV, Environmental Setting and Impacts.

The Proposed Project, with mitigation, would result in the following significant, unavoidable project-level and cumulative impacts. In many cases, mitigation measures would reduce the significant impact, but not to a less-than-significant level.

AESTHETICS

- Development under the Proposed Project would adversely alter scenic vistas of San Francisco and San Francisco Bay from public vantage points along the eastern shoreline of San Francisco, Telegraph Hill, the East Bay Shoreline, and from the Bay Bridge east span.

HISTORIC ARCHITECTURAL RESOURCES

- Demolition of the Damage Control Trainer, a battleship simulator known as the *U.S.S. Buttercup*, would impair the significance of an historical resource.

● ² San Francisco Planning Department, Notice of Preparation of an Environmental Impact Report and Notice of Public Scoping, Case No. 2010.0493E, February 9, 2011, available at www.sfmea/planning.org/2010.0493E_NOP.pdf, accessed February 15, 2011.

TRANSPORTATION

The following transportation impacts would be significant and unavoidable even with implementation of mitigation measures identified in the EIR:

- Construction of the Proposed Project would occur over a long period of time (15 to 20 years), and would result in significant impacts on the transportation and circulation network.

- Implementation of the Proposed Project would contribute to existing LOS E operating conditions during the weekday PM peak hour, and result in significant impacts during the Saturday peak hour at the eastbound off-ramp (west side of Yerba Buena Island).
- Under conditions without the Ramps Project, implementation of the Proposed Project would result in significant impacts at the two westbound Bay Bridge on-ramps.
- Under conditions with the Ramps Project, implementation of the Proposed Project would result in a significant impact during the AM and PM peak hours at the ramp meter at the westbound on-ramp (east side of Yerba Buena Island).
- Implementation of the Proposed Project would result in a significant impact on queuing at the Bay Bridge toll plaza during the weekday AM peak hour, with and without the Ramps Project.
- Implementation of the Proposed Project would result in a significant impact on queuing on San Francisco streets approaching the Bay Bridge during the weekday PM peak hour, under conditions with and without the Ramps Project.
- Implementation of the Proposed Project would result in a significant project impact at the signalized intersection of First/Market.
- Implementation of the Proposed Project would result in a significant project impact at the signalized intersection of First/Mission.
- Implementation of the Proposed Project would result in a significant project impact at the signalized intersection of First/Folsom.
- Implementation of the Proposed Project would result in a significant project impact at the signalized intersection of First/Harrison/I-80 Eastbound On-Ramp.
- Implementation of the Proposed Project would result in a significant project impact at the signalized intersection of Bryant/Fifth/I-80 Eastbound On-Ramp.
- Implementation of the Proposed Project would result in a significant project impact at the signalized intersection of Fifth/Harrison/I-80 Westbound Off-Ramp.
- Implementation of the Proposed Project would contribute substantially to existing LOS E conditions at the signalized intersection of Second/Folsom, resulting in a significant project impact.
- Implementation of the Proposed Project would result in a significant project impact at the uncontrolled intersection of Folsom/Essex.
- Implementation of the Proposed Project would result in a significant project impact at the uncontrolled intersection of Bryant/Sterling.
- Implementation of the Proposed Project would exceed the available transit capacity of Muni's 108-Treasure Island bus line serving the Islands.
- Implementation of the Proposed Project under conditions without the Ramps Project would impact AC Transit operations on Hillcrest Road between Treasure Island and the eastbound on-ramp to the Bay Bridge.
- Implementation of the Proposed Project under conditions with the Ramps Project would impact AC Transit operations on Treasure Island Road and Hillcrest Road between Treasure Island and the eastbound on-ramp to the Bay Bridge.

- The Proposed Project would increase congestion in downtown San Francisco, which would increase travel times and would impact operations of the Muni 27-Bryant bus line.
- The Proposed Project would increase congestion in downtown San Francisco, which would increase travel times and would impact operations of the Muni 30X-Marina Express bus line.
- The Proposed Project would increase congestion in downtown San Francisco, which would increase travel times and would impact operations of the Muni 47-Van Ness bus line.
- Construction of the Proposed Project would occur over a long period of time (15 to 20 years), and would contribute to cumulative construction impacts in the Project vicinity.
- Implementation of the Project would contribute to significant cumulative traffic impacts at the eastbound off-ramp (west side of Yerba Buena Island).
- Under conditions without the Ramps Project, implementation of the Proposed Project would contribute to significant cumulative impacts at the two westbound Bay Bridge on-ramps.
- If the westbound ramps on the east side of Yerba Buena Island are reconstructed as part of the Ramps Project, implementation of the Project would result in significant cumulative impacts during the AM and PM peak hours at the ramp meter at the westbound on-ramp (east side of Yerba Buena Island).
- Implementation of the Project would contribute to significant cumulative queuing impacts at the Bay Bridge toll plaza during the AM and PM peak hours, whether or not the Ramps Project is implemented.
- Implementation of the Project would contribute to significant cumulative queuing impacts on San Francisco streets approaching Bay Bridge during the weekday AM and PM and Saturday peak hours, whether or not the Ramps Project is implemented.
- Implementation of the Proposed Project would result in significant project and cumulative impacts at the intersection of First/Market.
- Implementation of the Proposed Project would result in significant project and cumulative impacts at the intersection of First/Mission.
- Implementation of the Proposed Project would result in significant project and cumulative impacts at the intersection of First/Folsom.
- Implementation of the Proposed Project would result in significant project and cumulative impacts at the intersection of First/Harrison/I-80 Eastbound On-Ramp.
- Implementation of the Proposed Project would result in significant project and cumulative impacts at the intersection of Bryant/Fifth/I-80 Eastbound On-Ramp.
- Implementation of the Proposed Project would result in significant project and cumulative impacts at the intersection of Harrison/Fifth/I-80 Westbound Off-Ramp.
- Implementation of the Proposed Project would result in a significant project and cumulative impacts at the intersection of Second/Folsom.
- Implementation of the Proposed Project would contribute to significant cumulative impacts at the uncontrolled intersection of Folsom/Essex.

- Implementation of the Proposed Project would contribute to significant cumulative impacts at the uncontrolled intersection of Bryant/Sterling.
- The Proposed Project would contribute to cumulative congestion in downtown San Francisco, which would increase travel time and would impact operations of the Muni 27-Bryant bus line.
- The Proposed Project would contribute to cumulative congestion in downtown San Francisco, which would increase travel time and would impact operations of the Muni 30X-Marina Express bus line.
- The Proposed Project would contribute to cumulative congestion in downtown San Francisco, which would increase travel time and would impact operations of the Muni 47-Van Ness bus line.
- The Proposed Project would contribute to cumulative congestion in downtown San Francisco, which would increase travel time and would impact operations of the Muni 10-Townsend bus line.
- Implementation of the Proposed Project parking supply maximums would exacerbate the exceedance of the capacity utilization standard on Muni's 108-Treasure Island bus line serving the Islands.

NOISE

The following noise impacts would be significant and unavoidable even with implementation of mitigation measures identified in this EIR:

- Project-related construction activities would increase noise levels above existing ambient conditions.
- Construction activities could expose persons and structures to excessive ground-borne vibration or ground-borne noise levels.
- Project-related traffic would result in a substantial permanent increase in ambient noise levels in the project vicinity above existing ambient noise levels.
- Project-related ferry noise levels would result in substantial permanent increase in ambient noise levels in the project vicinity above existing ambient conditions.

This impact would be significant and unavoidable only if the San Francisco Water Emergency Transportation Agency elects not to implement Mitigation Measure M-NO-4 to prepare and implement a noise reduction plan.

- Project-related construction activities in combination with construction activities of other cumulative development would increase noise levels above existing ambient conditions.
- Increases in traffic from the project in combination with other development would result in cumulative noise increases.

AIR QUALITY

- Construction of the Proposed Project could violate an air quality standard or contribute significantly to an existing or projected air quality violation.

Construction of the Proposed Project could affect regional air quality. Although less-than-significant under existing *CEQA Guidelines*, this impact would be significant and unavoidable because the Proposed Project would exceed the significance thresholds as quantified under the June 2010 BAAQMD CEQA Guidelines.

- Construction of the Proposed Project could expose sensitive receptors to substantial levels of toxic air contaminants which may lead to adverse health effects.
- Construction of the Proposed Project would expose persons to substantial levels of PM_{2.5} (particulate matter of 2.5 microns in diameter or less) which may lead to adverse health effects.
- The Proposed Project's operations would violate an air quality standard or contribute substantially to an existing or projected air quality violation.

The Proposed Project would result in emissions of criteria pollutant that would exceed the significance thresholds established by BAAQMD.

- Operation of the Proposed Project could expose sensitive receptors to substantial pollutant concentrations.
- The Proposed Project could result in significant cumulative air quality impacts.

WIND AND SHADOW

- The phased development of the Proposed Project could temporarily result in the creation of a Section 148 wind hazard, an increase in the number of hours that the wind hazard criterion is exceeded or an increase in the area that is subjected to wind hazards.
- Section 148 wind hazards would occur at publicly accessible locations in the Development Plan Area. These wind hazards would represent a general reduction in the number of existing wind hazards and the overall duration of the wind hazards. Changes in building design, height, location, and orientation, as well as changes in the overall configuration of the Project, could result in wind hazards that differ from those found for the representative design Project. The wind hazards could occur in different locations, could increase the number of hours that any wind hazard would occur, and/or could increase the area that would be subjected to wind hazards.
- The Proposed Project, when combined with other cumulative projects, could result in wind hazards that differ from those found for the representative design Project, either in the location of the hazard, in an increase in the number of hours that Section 148 wind hazards would occur, or in an increase in the area that is subjected to wind hazards.

BIOLOGICAL RESOURCES

- The project may adversely affect the movement of migratory birds, rafting waterfowl, and/or fish passage. This impact would be significant and unavoidable for rafting waterfowl, but less than significant for migratory birds and fish passage.
- Expanded ferry or water taxi services in San Francisco Bay are expected to contribute, along with the Proposed Project, to a cumulatively significant and unavoidable impact on rafting waterfowl.

This impact would be significant and unavoidable only if the San Francisco Water Emergency Transportation Agency elects not to implement Mitigation Measure M-BI-4b to modify ferry service to protect rafting waterfowl.

C. SIGNIFICANT IRREVERSIBLE ENVIRONMENTAL CHANGES WHICH WOULD BE CAUSED BY THE PROPOSED PROJECT SHOULD IT BE IMPLEMENTED

Significant irreversible environmental changes would occur with implementation of the Proposed Project. Generally, a project would result in significant irreversible environmental changes if:

- The primary and secondary impacts of the project would generally commit future generations to similar uses;
- The project would involve uses in which irreversible damage could result from any potential environmental accidents associated with the project; or
- The project would involve a large commitment of nonrenewable resources and the proposed consumption of resources is not justified (e.g., the project involves the wasteful use of energy).

Development of the Proposed Project would result in the long-term conversion of a former military base to a mixed-use urban development that would provide new and enhanced open space, and new and/or improved transportation and utility infrastructure which would be a long term commitment to future generations of a similar use. This change in use, however, is consistent with long-term changes to land use within the region as directed and encouraged by local and regional planning agencies, including ABAG's designation of Treasure Island as a Priority Development Area, as part of its FOCUS Program as discussed in Section A, Growth Inducing Impacts, on p. V.2.

The Proposed Project would not involve uses in which irreversible damage could result from potential environmental accidents. For the Proposed Project, such accidents would be primarily associated with release of, or exposure to, hazardous materials. The Navy would be responsible for completing its remediation responsibilities under the requirements of the Comprehensive Environmental Response and Liability Act ("CERCLA") and the Petroleum Program. The

Navy's compliance with these statutory requirements would mitigate potential irreversible damage that could occur from release of or exposure to hazardous materials.

Development of the Proposed Project would involve a commitment of nonrenewable resources to construct buildings and infrastructure, including lumber, concrete, sand, gravel, masonry, metals, and water. However, development would not be expected to involve an unusual commitment of these resources, nor would it be expected to consume any of these resources in a wasteful manner. The Proposed Project's *Sustainability Plan* includes reuse and recycling goals for demolition of existing structures that would reduce the amount of resources used both in the Proposed Project and elsewhere.

Construction of buildings and infrastructure, and occupancy at buildout, would use energy resources in the form of fossil fuels. During construction, diesel and gasoline fuels would be consumed to operate construction equipment. During operation, diesel and gasoline fuels would be consumed to operate the buses and ferries that would provide transportation to and from the Islands, and for the automobiles and trucks that would visit the Islands. Natural gas would be used for heating and cooling. Because individual buildings would be required to meet or exceed the energy conservation requirements in the San Francisco Green Building Ordinance, which itself includes energy conservation requirements that exceed those in the California Building Code, energy would not be used in a wasteful, inefficient, or unnecessary manner. In addition, the Proposed Project includes a commitment to produce at least 5 percent of its energy demand from on-site renewable sources, further reducing the irreversible use of fossil fuels.

D. AREAS OF KNOWN CONTROVERSY AND ISSUES TO BE RESOLVED

Reuse of Treasure Island and Yerba Buena Island following transfer from the Navy to TIDA has been under discussion for over 15 years. TIDA and TICD, as co-project sponsors, have been working with the Treasure Island / Yerba Buena Island Citizens Advisory Board, the TIDA Board, the Planning Commission, and the Board of Supervisors, multiple city, regional and State agencies, and a large number of other project stakeholders to establish a program of development that would fulfill the various objectives articulated by these groups. Issues raised over the course of the planning process have related to providing affordable housing, preserving and enhancing the natural habitat on Yerba Buena Island, providing access to the new uses on the Islands with the least possible impacts on traffic, providing sufficient transit service, and developing an environmentally sustainable development.

During public scoping for this Environmental Impact Report ("EIR") in February 2008, many of these issues were raised by public agencies, community and environmental organizations, and interested individuals. Since then, the Development Program has been revised by TIDA and TICD, responding to some of the key concerns, as reflected in the Development Update endorsed

by the TIDA Board and Board of Supervisors in May 2010. For example, comments during public scoping suggested that a higher density development would provide better support for the proposed transit services and the retail uses. This resulted in an increase in the Proposed Project from 6,000 to 8,000 residential units. A draft *Habitat Management Plan* for Yerba Buena Island has been prepared for the Proposed Project, as well as a *Sustainability Plan*. Public scoping comments recommended parking charges for all spaces, mandatory transit pass purchase for residents, and priority access to the Bay Bridge for buses and emergency vehicles, all of which are included in the Proposed Project.

Other issues of concern raised during the public scoping for the EIR include the following:

- Traffic impacts that would result from the Proposed Project. Traffic impacts should be addressed with additional features such as community-wide membership in a car-share program; mandatory transit passes for residents, employees and hotel guests; increased bicycle parking and shuttles; and convenient access to on-Island retail.
- No parking minimum or parking maximum requirements should be imposed.
- CO₂ emissions (related to greenhouse gas impacts) should be reduced.
- A no-ferry alternative should be analyzed.
- Public access to the shoreline should be supported and enhanced.
- Energy consumption should be reduced, and renewable energy goals should be higher than proposed.
- Use of potable water should be reduced by maximum use of recycled and gray water systems and climate-appropriate landscaping.

Most of these other issues of concern have also been incorporated into components of the Proposed Project. As described in Chapter II, Project Description, p. II.51, the Proposed Project would include formation of the Treasure Island Transportation Management Agency (“TITMA”). TITMA would oversee transit services and implement a series of transportation demand measures to encourage use of transit, free on-island shuttle service for both Islands, a car-share program, bicycle rental system, mandatory purchase of pre-paid transit voucher by household and hotel visitors, and support for vanpool and carpool matching services. All of these elements would reduce traffic generated by the Proposed Project. Traffic impacts of the Proposed Project are discussed in Section IV.E., Transportation. Other considerations to reduce traffic are discussed under Section D.5 Measures to Reduce Automobile Ownership, p. VII.77.

The Proposed Project also would provide 300 acres of new and enhanced parks and open space, which would include shoreline access. An approximately 3.0-mile-long, publicly accessible multi-use path would be developed around the perimeter of Treasure Island, which is planned to be an extension of the San Francisco Bay Trail; refer to Section IV.J, Recreation, p. IV.J.16 for a description of this perimeter path.

The draft *Design for Development* for the Proposed Project provides for an island-wide maximum parking ratio of one parking space per dwelling unit. The impacts of this parking requirement are analyzed in Section IV.E, Transportation, on pp. IV.E.140-IV.E.141.

Section IV.H, Greenhouse Gases, analyzes a number of project design features related to land use mix and density, transportation management measures, use of renewable energy, and other project elements that would reduce greenhouse gas emissions.

The *Infrastructure Plan* for the Proposed Project includes a renewable energy component. Additionally, the project sponsors have committed to meeting 5 percent of peak electric demand with on-site renewable sources. These project components are discussed in Section IV.Q, Energy and Mineral Resources. As described in Section IV.K, Utilities and Service Systems, p. IV.K.14, the use of recycled water for irrigation and other purposes is a major component of the Treasure Island *Sustainability Plan*.

A no-ferry alternative is addressed in this EIR under Alternative C, No Ferry Service Alternative, in Chapter VII, Alternatives to the Proposed Project, p. VII.48.

VI. PROJECT VARIANTS

This chapter describes and discusses several variations on infrastructure features of the Proposed Project that are under consideration by the project sponsors. The variants modify one limited feature or aspect of the Proposed Project, unlike the Alternatives to the Proposed Project described and analyzed in Chapter VII, Alternatives, that provide a different approach to the Proposed Project. Therefore, each variant is the same as the Proposed Project except for the specific variation described. Each variant would be available for selection by the project sponsors and decision makers, and several variants could be included in the Proposed Project as part of an approval action.

The energy variants cover a variety of renewable energy facilities and energy efficiency measures that are under consideration by the project sponsors but have not been confirmed to be part of the Proposed Project. Three additional breakwater systems for the Ferry Terminal are described, and there are two additional approaches to providing supplemental water for firefighting. Wetlands could be constructed on Treasure Island either to provide additional treatment to wastewater effluent prior to discharge to the Bay or to provide one step in the treatment process for recycled water. An automated collection system for solid waste is under consideration for Treasure Island. Finally, several improvements in off-site electrical transmission facilities could be made, although they are not necessary to serve the Proposed Project's electricity demand. For each variant, all other features of the Development Program would be the same as or similar to the features of the Proposed Project.

This chapter describes each variant and provides an analysis of environmental impacts of the variant that would be different from impacts identified for the Proposed Project in Chapter IV, Environmental Setting and Impacts. Additional mitigation measures are identified when applicable.

A. ENERGY VARIANTS

INTRODUCTION

As explained under "Proposed Project Facilities," in Section IV.Q, Minerals and Energy Resources, p. IV.Q.10, the Proposed Project would include renewable electricity generation on Treasure Island. The project sponsors have committed to providing an equivalent of 5 percent of peak electric demand with on-site renewable sources, such as solar photovoltaic. This target would be achieved by designing building rooftops to accommodate photovoltaic systems, and potentially using solar water heating. With current technology, about 1.4 to 3 acres of

photovoltaic panels in open space areas or on roof-tops¹ would be required to meet the target of 5 percent of the peak power demand.

The Proposed Project would incorporate a variety of energy efficiency (in other words, energy conservation) measures aimed at achieving 20 percent overall improvement on the requirements under California Title 24 regulations.

There are several energy variants under consideration. These would increase energy efficiency through different technologies and/or increase the production of energy from renewable resources above the 5 percent included in the Proposed Project. The discussion below begins with the probable sites for some of the renewable energy facilities, and then presents a variety of approaches to providing district energy facilities. Roughly, the discussion goes from simplest to most complicated.

VARIANT A1. RENEWABLE ELECTRICITY GENERATION – INCREASED SOLAR PHOTOVOLTAIC

Description

The Proposed Project would include about 1.4 to 3 acres of roof-mounted photovoltaic panels to meet the goal of producing at least 5 percent of the peak power demand. The Proposed Project includes sufficient roof-tops to meet this goal, and the draft *Design for Development* would permit roof-mounted photovoltaic systems on all buildings, including historic Buildings 1, 2, and 3. If panels were to be installed on the historic buildings, they would be required to meet the United States Secretary of the Interior's *Standards for Rehabilitation*.

Energy Variant A1 would increase the area devoted to solar photovoltaic technology. This variant would provide up to 20 acres of ground- or structure-mounted photovoltaic panels in open space areas on the eastern and northern shorelines of Treasure Island and/or in the center of the island near the Urban Agricultural Park. The 20 acres devoted to photovoltaic panels would be in addition to the 1.4 to 3 acres incorporated into the Proposed Project. The exact location where these photovoltaic panels would be installed has not been identified. A total of 28 acres has been tentatively identified as potentially available for this use.² Figure VI.1: Potential Locations for Ground-Mounted Solar Panels, shows potential open space areas that could be used.

¹ Arup North America Ltd., *Treasure Island Development Energy Study*, prepared for TICD, December 2009, p. 4 (hereinafter referred to as “2009 Energy Study”). A copy of this document is available for public review at the San Francisco Planning Department, 1650 Mission Street, Suite 400, in Case File No. 2007.0903E.

² Memorandum from Alexandra Galovich, TICD (Wilson Meany Sullivan), to TI/YBI RP EIR Team, re “Changes to Project Description for PUC-related Items,” dated September 14, 2009 (hereinafter “Galovich 9/14/09 memorandum”). A copy of this document is available for public review at the San Francisco Planning Department, 1650 Mission Street, Suite 400, in Case File No. 2007.0903E.

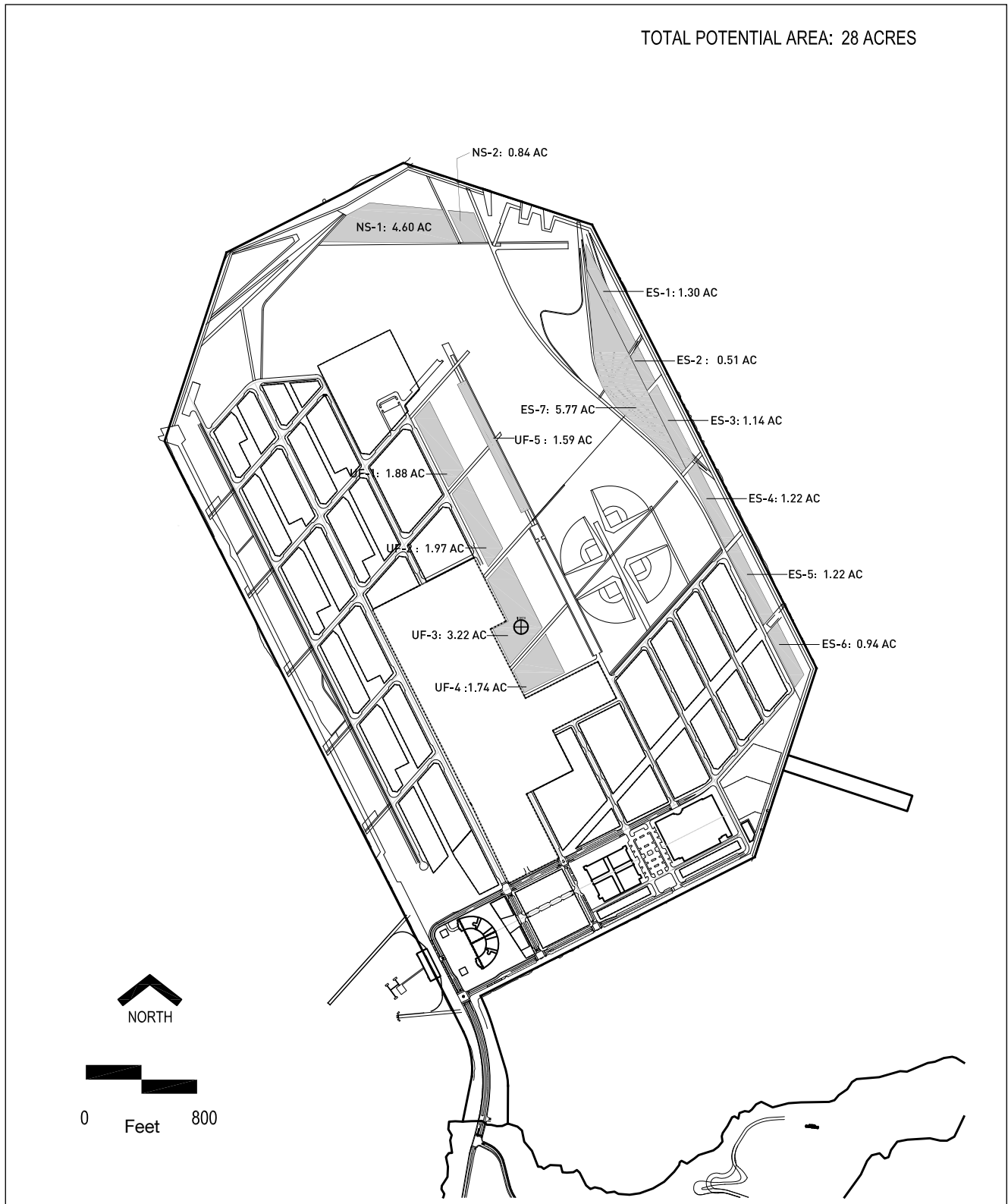

SOURCE: CMG

TREASURE ISLAND AND YERBA BUENA ISLAND REDEVELOPMENT PROJECT EIR

FIGURE VI.1: POTENTIAL LOCATIONS FOR GROUND-MOUNTED SOLAR PANELS

Photovoltaic panels would be oriented to the south and tilted to maximize electricity generation given site constraints.

The purpose of this Variant A1 is to allow the production of more renewable energy than would be achieved by the Proposed Project's target of 5 percent renewable energy. Implementation of this Variant would require investment in substantial energy generation facilities and implementation of power purchase agreements that facilitate feeding excess energy back into the power grid; no one has committed to funding such facilities and power purchase arrangements have not been negotiated. In addition, implementation of Variant A1 would either reduce or change the nature of a portion of the overall amount of usable open space within the Development Plan Area, and the TIDA Board of Directors has not yet made a decision to endorse such a change.

Impact Evaluation

Land Use and Recreation

The Proposed Project envisions the creation of a system of neighborhood parks, playgrounds, and open spaces with public plazas, courtyards, and greenways, as well as walking and biking paths. In total, the Proposed Project would create approximately 300 acres of open space. Under this variant, about 14.2 acres within the 56-acre Northern Shoreline Park, up to 3.4 acres within the 7-acre Eastern Shoreline Park, and up to 10.4 acres within the 20-acre Urban Agricultural Park have been identified as potential areas to receive 20 acres of photovoltaic "farms." These facilities use small electrical motors that would operate very quietly and, aside from periodic maintenance, these facilities would not require personnel on site. Depending on the technology selected, they may be surrounded by fencing for security. The potential locations of the photovoltaic "farms" within the Northern Shoreline Park or the Eastern Shoreline Park would not interfere with the San Francisco Bay Trail and would not limit access to the Bay from around the perimeter of Treasure Island.

Land use and recreational impacts under Variant A1 would be the same as or similar to the environmental impacts addressed in Section IV.A, Land Use and Land Use Planning, and Section IV.J, Recreation, for the Proposed Project except as described below. This variant would reduce the amount of proposed recreational and open space under the Proposed Project by 20 acres, from approximately 300 acres to approximately 280 acres of recreational and open space. Although recreational activities would be precluded within these facilities, the quiet operation of these facilities would not be incompatible with the recreational and open space character of adjacent parkland. Based on an estimate of 280 acres, the ratio of residents to acres of recreation areas and open space would be approximately 15 acres per 1,000 residents, which is greater than the current Citywide ratio of about 8 acres of recreation areas and open space per 1,000 residents. The ratio of residents and employees (i.e., daytime population) to acres of recreation areas and

open space would be approximately 13 acres per 1,000 residents/employees. Therefore, land use and recreational impacts under Variant A1 would be less than significant as described in Section IV.A, Land Use and Land Use Planning and Section IV.J, Recreation, for the Proposed Project, and would not change the analysis or conclusions presented there.

Aesthetics

Aesthetics impacts under Variant A1 would be the same as or similar to those addressed in Section IV.B, Aesthetics, for the Proposed Project, except as described here. Viewed from mainland locations, the impacts on scenic vistas and visual quality of this variant would be similar to those described for the Proposed Project. At no higher than 12 feet, the photovoltaic installations would not be prominent from a distance and within the context of proposed new development on Treasure Island. Figure VI.2: Potential Design Configurations of Solar Panels, presents possible configurations of ground-based and roof-based solar panels.

Under existing conditions, expansive scenic Bay vistas from Treasure Island are available to the public from its shoreline and perimeter road. Scenic Bay vistas from further inland are limited by existing buildings and vegetation. The Proposed Project calls for demolition of existing structures and the development of new waterfront public open space at the northern and eastern ends of the Island (the Northern Shoreline Park and the Eastern Shoreline Park). Creation of these public open spaces would create new interior public open spaces from which expansive scenic Bay vistas would be available (toward Mount Tamalpais, Angel Island, the Marin hills, the Richmond-San Rafael Bridge, Point Richmond and the East Bay hills).

Under this variant, up to about 14.2 acres within the 56-acre Northern Shoreline Park, and up to 3.4 acres within the 7-acre Eastern Shoreline Park, potentially could be devoted to fenced photovoltaic “farms.” These facilities would be utilitarian and industrial in visual character. Depending on the technology used, they may be surrounded by fencing for security. Compared to the Proposed Project, this variant would offer up to 17.6 acres less open space along the northern and eastern edges of the island from which expansive scenic Bay vistas would be available to the public.³ To the extent that scenic vistas to the north and east may also be available from other proposed public open spaces in the interior of the island (such as the Wetlands, the Wilds, the Sports Park, and the Urban Agricultural Park), the placement of photovoltaic farms at the northern and eastern perimeter of the island, could obstruct or degrade the visual quality of views from these areas as well. However, the impact of this variant on scenic vistas from the island would be considered less than significant, because scenic Bay vistas

³ The remaining 9.4 acres of recreational and open space that could be used for photovoltaic “farms” would be located inland and would not affect scenic Bay views.



At Grade – Fixed Tilt



At Grade – Single Axis Tracking

SOURCE: Solar Colorado, South San Joaquin Irrigation District, TICD

would continue to be available to the public from the northern and eastern shorelines as under existing conditions. In addition, about 45.4 new acres of new parkland would remain along the northern and eastern shorelines under this variant (compared to existing conditions) from which scenic Bay vistas would become available to the public, the same as with the Proposed Project.

Solar panels are designed to absorb a high percentage of sunlight as part of their intrinsic purpose, which is to collect the energy of the sun. They are typically dark colored and constructed with anti-reflective glass or at least one layer of anti-reflective coating. They would not be a significant source of glare and would not substantially alter the amount of reflected sunlight in this setting at the center of the reflective surface of San Francisco Bay. For these reasons, the potential for impacts related to glare from solar panels under this variant would be less than significant. No mitigation is required.

In summary, impacts related to aesthetics under Variant A1 would not change the analysis or conclusions in Section IV.B, Aesthetics, for the Proposed Project.

Archaeological and Paleontological Resources

Although the placement of solar panels would result in some soils disturbance on Treasure Island, it would not extend to any depths that could reach any undisturbed soils. Impacts related to archaeological and paleontological resources under Variant A1 would not change the analysis or conclusions in Section IV.D.1, Archaeological and Paleontological Resources, for the Proposed Project.

Historic Architectural Resources

As with the Proposed Project, installation of photovoltaic panels on historic Buildings 1, 2 or 3, under this alternative would be required to meet the United States *Secretary of the Interior's Standards for Rehabilitation*. A project that conforms to the Secretary Standards is considered to have a less-than-significant impact on an historical resource under CEQA (*CEQA Guidelines* Section 15064.5(b)(3)). Impacts related to historic architectural resources under Variant A1 would not change the analysis or conclusions for the Proposed Project in Section IV.D.2, Historic Architectural Resources.

Noise

Construction of solar panels over a larger area of open space and/or rooftops would cause temporary construction noise. The noise would be similar to noise from construction of other structures, and would not result in new significant impacts different from those discussed in Section IV.F, Noise. If panels are designed to adjust to the optimal angle of incidence with the movement of the sun, there could also be localized motor noise at the stanchion. Motor noise would need to conform to the requirements of the San Francisco Noise Ordinance. Motors to

adjust panels would be small, electrical motors that would produce low levels of noise; for this reason, compliance with the City's noise ordinance would be feasible. Therefore, noise impacts under Variant A1 would be less than significant and no new mitigation measures are required.

Air Quality

Installation of additional solar panels would result in construction dust and equipment and truck emissions. The installation of these solar panels would not materially change the nature or scope of construction activities generally. Significant construction-related air quality impacts with this variant included in the Proposed Project would be similar to those described Section IV.G, Air Quality, for the Proposed Project, and would not change the analysis or conclusions there or the mitigation measures identified to limit these impacts.

Greenhouse Gases

Installation of additional solar panels would result in construction equipment and truck emissions. These air quality impacts would be similar to those described Section IV.H, Greenhouse Gas Emissions, for the Proposed Project, and would not change the analysis or conclusions there. Operation of the additional panels would result in somewhat lower greenhouse gas emissions than the Proposed Project by reducing the contribution of non-renewable energy which generates greenhouse gases. It would not change the conclusion applicable to the Proposed Project that contributions to greenhouse gas emissions would be less than significant.

Wind and Shadow

Ground-mounted solar panels would add new areas of shadow in areas proposed for open space in the Proposed Project. As discussed above in "Land Use and Recreation," a substantial amount of open space would continue to be available to residents of the Islands and to regional visitors who come to the Islands for recreational purposes. Therefore, while the additional shadow might make portions of the open space less attractive to some, it would not significantly impact the availability of open space for local and regional residents and visitors. It is not expected that ground-mounted solar panels would substantially change wind conditions.

Utilities and Service Systems

Utilities and service systems impacts under Variant A1 would be the same as or similar to the environmental impacts addressed in Section IV.K, Utilities and Service Systems, for the Proposed Project. This variant would include additional electrical distribution wires and equipment to transmit the additional solar power within Treasure Island and, when not needed on Treasure

Island, back into the electrical grid beyond the island.⁴ During times when on-island electricity production might exceed on-island demand, the distribution lines (e.g., 12 kV submarine cables and equipment in Oakland) would be adequate to handle the reverse flow of electricity back to the Davis Substation.⁵ Therefore, the Proposed Project's environmental impacts associated utilities and service systems under Variant A1 would be less than significant as described in Section IV.K, Utilities and Service Systems, for the Proposed Project, and would not change the analysis or conclusions presented there.

Biological Resources

Ground-mounted solar panels would shade the ground under and near the panels. Assuming the panels would be constructed in open space areas, landscaping plants in the resulting shady areas would need to be shade-tolerant. This would not result in significant impacts on existing or proposed biological resources, as it would simply change the potential plant palette available to the landscape designers. Therefore, no new impacts would result, and no new mitigation measures would be needed.

Hazards and Hazardous Materials

Hazards and hazardous materials impacts under Variant A1 would be the same or similar to the environmental impacts addressed in Section IV.P, Hazards and Hazardous Materials, for the Proposed Project. Solar panels contain electrical components which can include hazardous materials such as either cadmium telluride or crystalline silicon, both commonly used in solar panel construction. Panels typically arrive at the construction site as pre-fabricated, sealed, self-contained units. Once operational, the Proposed Project would not require the routine transport of hazardous material to or from the project site. On occasion, maintenance activities may produce small amounts of waste, including broken and rusted metal, defective or malfunctioning modules, electrical materials, empty containers and other miscellaneous solid wastes, including the typical refuse generated by workers. Improper handling of crystalline silicon containing panels could expose silicone dust which is hazardous to workers or anyone exposed to inhalation of the dust. Any occasionally defective or broken solar modules would likely be returned to the manufacturer for proper recycling, as often required by the manufacturer. Operational activities could generate biodegradable dielectric fluid and mineral oil from the transformers and miscellaneous electrical equipment. Spent oil would be collected and delivered to a recycling company at the time it is removed from the equipment, and would not be stored on-site. Transformers are generally provided with full secondary containment. However, the mineral oil would not normally require replacement.

⁴ There is no environmental-impact significance criterion regarding adequacy of electricity, natural gas, and telecommunications delivery infrastructure.

⁵ Personal communication with project sponsors' engineering consultants regarding utilities, Nov. 9, 2009.

The solar modules can also contain cadmium telluride or CdTe, which acts as a semiconductor in thin film solar panel technology. It has been used successfully in solar panels because it resists corrosion and chemicals, and has a high tolerance for high temperatures. It also has a low melting point and is an excellent conduit of electricity. Cadmium (Cd) is a by-product of zinc, lead, and copper mining. Tellurium (Te) is a semi-metallic element, which when combined with cadmium produces the compound CdTe. A broken panel could result in exposure to CdTe, and improper handling of CdTe can result in respiratory-related health risks. However, generally workers are required to receive appropriate training in safe handling and transport procedures. The potential for release of hazardous materials would not be significant during installation or operation.

In summary, the Proposed Project's hazards and hazardous materials impacts under Variant A1 would be less than significant as described in Section IV. P, Hazards and Hazardous Materials, for the Proposed Project, and would not change the conclusions or the mitigation measures identified there.

Hydrology and Water Quality

Ground-mounted solar panels in areas that would otherwise be used as open space, along the center of Treasure Island or along its eastern and northern shorelines, could result in additional hydrology and water quality effects. Installation of the solar panels would subject up to an additional 20 acres of area to construction activities. These activities would be subject to stormwater permitting and associated control measures. During operations, the solar panels would function similarly to additional impervious surface area. However, these facilities would be subject to the stormwater runoff control measures discussed in Section IV.O, Hydrology and Water Quality, including the new storm drain system and stormwater BMPs, to ensure that downstream flooding, erosion, and sedimentation do not increase. Finally, depending upon the technology used, the proposed solar panels could require washing, which would periodically consume a small amount of water. Considering that the maximum proposed amount of solar arrays would be 20 acres, and that washing would be periodic in nature, any additional water use for washing of solar panels is expected to be negligible. Therefore, hydrology and water quality impacts under Variant A1 would be less than significant as described in Section IV.O, Hydrology and Water Quality, for the Proposed Project, and would not change the conclusions or mitigation measures identified there.

Mineral and Energy Resources

Regarding energy resources, Variant A1 would produce more on-site renewable electricity than the Proposed Project. This would offset or reduce the Proposed Project's electricity demand, and no significant impact on energy resources would result. As stated in Section IV.Q, Mineral and Energy Resources, there are no mineral resources on the Island and no impacts on mineral

resources would occur with the Proposed Project; Variant A1 would not change this conclusion. Therefore, the Proposed Project's environmental impacts associated with mineral and energy resources under Variant A1 would be less than significant as described in Section IV. Q, Mineral and Energy Resources, for the Proposed Project, and would not change the analysis or conclusions there.

Other Topics

The topics of population and housing, transportation, geology and soils, and agricultural resources and forest land would not change if Variant A1 were implemented.

VARIANTS A2 AND A3. DISTRICT ENERGY HEATING AND COOLING

Description

The Proposed Project assumes all heating and cooling are done at the individual building level and independent from adjacent buildings. PG&E or SFPUC would provide electricity, except for part or all of the renewable electricity generated on-site, and PG&E would provide natural gas. This group of Energy Variants would provide heating and cooling for some groups of buildings from a central location rather than on a building-by-building basis, and could also produce some on-site power.

District Energy means using a centralized location to provide heating and cooling for a group of residential and commercial buildings. Hot water may be used for space heating and water heating. Chilled water may be used for space cooling. District Energy plants generally provide higher efficiencies and better pollution control than boilers and chillers located in each building. A District Energy plant could also be designed to provide on-site power generation. Energy Variant A2 would provide for a District Energy plant with heating and cooling only; Energy Variant A3 would provide heating, cooling, and power generation. There are also three subvariants that would apply to either of these Energy Variants, described below. (Neither variant would provide District Energy on Yerba Buena Island.) The stated purpose of these District Energy options is to provide greater efficiency, reduce distribution infrastructure, and provide additional energy options with the intent of reducing the overall energy use and air pollutant emissions from operation of the Proposed Project. The Impact Evaluation for this set of variants follows the summary description of the subvariants.

A single large central heating and cooling plant such as that proposed in Variant A2 was included in the Development Plan in 2006. This plant was expected to provide hot and chilled water to buildings in the Island Center, primarily the towers. Variant A3 would be similar to A2, but adds a power production component. Upon further evaluation and discussion with industry providers, it was determined that, while a single large central heating and cooling plant (with or without power production) could be built, it would be difficult to phase and would have a long payback

period. Subvariant B attempts to address these challenges by proposing smaller and more distributed district plants that may be more feasible to implement because they could be built in phases, would occupy less space and could pay for themselves over a shorter period of time. Nevertheless, construction of such plants would still require a third party operator to invest funds to construct each district plant in advance of individual buildings being built, on the expectation that the future buildings would purchase the heating and cooling from them. While heating and cooling districts do exist, they are not part of the Proposed Project and there is no identified funding source. Therefore, the feasibility of Variants A2 and A3, as well as their associated subvariants, is uncertain.

Energy Variant A2, District Heating and Cooling

There are many technological options available for the District Energy Plant or Plants under Energy Variants A2 and A3, including boilers, fuel cells, micro-turbines, steam turbines, and natural gas fired engines. For the sizes of facilities contemplated for development on Treasure Island, the most likely option for Variant A2 would be natural gas-fired steam boilers.

Under Variant A2, piping would carry hot and cool water from one or more central plants to nearby buildings for space heating, hot water, and space cooling. After use, the water would be returned to the central plant for re-heating or re-cooling. The distribution infrastructure would be the same for Energy Variants A2 and A3, including any of the subvariants described below.⁶ The piping would consist of insulated supply and return piping located in utility trenches below grade, primarily under new streets. The location and depth of the pipes for these systems would be consistent with other low pressure water utility piping. Connections to buildings would include meters for accounting and billing purposes.

Energy Variant A3, District Energy Heating, Cooling, and Power

Like the variant above, Energy Variant A3, District Energy Heating, Cooling, and Power, would provide heating and cooling to buildings around one or more central plants. The plants in Energy Variant A3 would also generate electricity.

For Energy Variant A3, the likely technologies include natural gas-fired steam boilers for heating and making steam, and steam turbines or natural-gas fired combustion turbines for power production. The electric generation portion of plant is likely to have a capacity of 1 to 3 MW.⁷

With a steam turbine, a natural gas-fired boiler would create steam that would turn a turbine to create electricity. Waste heat in the form of steam and condensate would be converted to hot

⁶ Galovich 9/14/09 memorandum, p. 15-17.

⁷ Galovich 9/14/09 memorandum, p. 14.

water via a heat exchanger. An absorption chiller would also use the waste heat to make chilled water. Cooling towers would still be needed for getting rid of waste heat (i.e., “heat rejection”).

With a natural-gas fired combustion turbine, the turbine would turn the generator directly. Waste heat would be recovered from the engine jacket and flue stack.

As under Energy Variant A2, piping would carry hot and cool water from the central plants to nearby buildings. After use, the water would be returned to the central plants for re-heating or re-cooling.

Subvariants for Energy Variants A2 and A3

Three subvariants could be applied to either Energy Variant A2 or A3. These subvariants are not mutually exclusive; they could be implemented separately or together.

District Energy Subvariant A is alternative heat rejection: either dry cooling towers or combination wet-dry cooling towers would be used. Dry cooling towers would be larger and taller than wet cooling towers, by about 30 to 50 percent. The advantage of dry cooling towers is less visible mist, which is sometimes created by wet cooling towers under certain meteorological conditions.

District Energy Subvariant B consists of satellite District Energy plants. Satellite plants would be used in the Cityside District and the Eastside District to provide redundancy and/or distribution efficiency and for phasing. Satellite facilities would have smaller footprints than the central plant, would be a similar height, and could either be separate structures or be integrated into one or more buildings in their neighborhood. Inclusion of satellite district plants would allow the central plant to be smaller, but the overall footprint of all facilities in this Subvariant would be larger than with the use of one central plant. The satellite plants would be built sequentially along with the construction phases, beginning with the southwestern plant in the midst of the central core.

District Energy Subvariant C would include solar thermal energy. Under this subvariant solar thermal energy systems may be used to collect heat for district heating and to heat water that could provide heat and also drive chillers for district cooling. The panels would most likely be either evacuated tube or concentrating solar devices that can produce hotter water than flat-plate collectors over the majority of the year. The collectors would be on building roofs or the upper level of a parking structure, adjacent to the central heating and cooling plant. Other equipment to operate the solar collectors would include pumps, heat exchangers, storage tanks and control systems in an approximately 800-square-foot structure for about 10,000 sq. ft. of solar collectors.

All the subvariants assume for the purposes of energy calculations and load sizing that low-rise residential buildings on Treasure Island would not have cooling systems and would not be served by a district heating/cooling facility.

Impact Evaluation

Land Use

Land use and recreational impacts under Energy Variants A2 or A3 would be the same as or similar to the environmental impacts addressed in Section IV.A, Land Use and Land Use Planning, for the Proposed Project, except as described here.

District Energy facilities would either be separate structures or integrated into parking garages, or for solar-thermal technology (Subvariant C), possibly on roofs. If integrated into proposed parking garages or on roofs, they would not add to the overall footprint of the Proposed Project.

The facilities would use less floor area and roof area than the combined heating and cooling facilities for individual buildings in the Proposed Project.⁸ Thus, there would be more useable floor area in individual buildings of the same size if central heating and cooling were provided as in this Variant. If the central plant were a separate structure rather than included in one or more parking garages, it would take up about 12,000 to 18,000 sq. ft. of ground area. Being an infrastructure use in the highly concentrated, mixed use, Island Center District, the central plant would be sited near a parking garage and/or commercial uses. The central plant would be a complementary land use that would support building functions and would be designed to conform to the design guidelines for new construction set forth in the draft *Design for Development*. The central plant would conform to the design guidelines related to industrial and infrastructure buildings and would also be subject to setbacks and screening. Therefore, similar to above-grade parking garages, the central plant would be compatible with the character of the adjacent land uses. This variant would not result in new significant land use impacts, as with the Proposed Project.

District Energy Subvariant B, with satellite district plants, would have a larger overall footprint considering all District Energy facilities, but would still result in more useable floor area in individual buildings than if each building had separate heating and cooling facilities. Because the central and satellite plants would be integrated within parking garages or placed near parking garages and commercial space, their presence and operation would be compatible with adjacent land uses. As with any proposed new building on Treasure Island under the Proposed Project, this variant would be required to conform to the design standards and guidelines for new construction on Treasure Island included in the draft *Design for Development*. Conformity with

⁸ 2009 Energy Study, p. 36.

approved design guidelines in the draft *Design for Development* would ensure that new buildings under this variant would be compatible with the character of adjacent land uses.

In summary, land use impacts under Energy Variants A2 and A3, including subvariants, would be less than significant as described in Section IV.A, Land Use and Land Use Planning, for the Proposed Project, and would not change the analysis or conclusions there.

Aesthetics

Aesthetics impacts under Energy Variants A2 and A3 would be the same or similar to those addressed in Section IV.B, Aesthetics, for the Proposed Project, except as described here.

The central plant would be from 30 to 40 feet tall, assuming that cooling towers were on its roof. Dry cooling towers would be larger and taller than wet cooling towers, by about 30 to 50 percent. Viewed from mainland locations, the impact on scenic vistas and visual quality of this variant would be substantially the same as that described for the Proposed Project. The central plant would not be a prominent feature viewed from a distance and within the context of proposed new development on the island, if discernable at all. Although the wet cooling towers would be smaller than dry cooling towers, wet cooling towers create plumes of mist under certain meteorological conditions, which would be visible from a greater distance.

As with any proposed new building on Treasure Island under the Proposed Project, this variant would be required to conform to the design standards and guidelines for new construction on Treasure Island included in the draft *Design for Development*. Conformity with approved design guidelines in the draft *Design for Development*, e.g. design guidelines for industrial and infrastructure buildings under T5.9 and guidelines that govern setback and screening standards for industrial uses located in residential areas, would ensure that this variant would not cause a significant adverse impact on the visual quality of Treasure Island.

In summary, aesthetics impacts under Energy Variants A2 and A3, including subvariants, would not change the analysis or conclusions in Section IV.B, Aesthetics, for the Proposed Project.

Noise

Noise impacts under Energy Variants A2 and A3 would be the same or similar to those addressed in Section IV.F, Noise, for the Proposed Project, except as described here.

Construction of District Energy facilities would cause temporary construction noise. Construction noise would be similar to that discussed for construction of the Proposed Project in Section IV.F, Noise. Mitigation Measures M-NO-1a and M-NO-1b, pp. IV.F.16 – IV.F.17 would decrease construction noise levels by requiring construction contractors to implement noise

reduction measures for construction activities. Therefore, construction of these variants would not result in new significant impacts not identified in that section of the EIR.

Both Variants A2 and A3, and the related subvariants, would generate mechanical noise. As with the Proposed Project, implementation of Mitigation Measure M-NO-6, p. IV.F.29, would ensure that adequate performance of noise attenuating features such as a noise reducing shield would be achieved. Similar to the Proposed Project, operational noise levels under these variants would be monitored, and if stationary noise sources were found to exceed the applicable noise standards, additional noise attenuation measures would be applied in order to meet the applicable noise standards. Therefore, noise impacts under Energy Variants A2 and A3, including subvariants, would not change the conclusions or mitigation measures identified in Section IV.F, Noise, for the Proposed Project.

Air Quality

Installation of District Energy facilities would result in construction dust and equipment and truck emissions. These construction air quality impacts would be similar to those described Section IV.G, Air Quality, Impacts AQ-1 through AQ-4, for the Proposed Project, and would not change the significance determinations. The same mitigation measures, M-AQ-1, M-AQ-2, and M-AQ4, pp. IV.G.26 - IV.G.38 would apply.

Regarding operations, Variant A2 would likely have less emissions related to natural gas burning than the Proposed Project, because the centralized (or satellite) plants would be more efficient, and would burn less natural gas than individual heating equipment in each building under the Proposed Project. Variant A3 would burn more natural gas on-site than the Proposed Project, and would have more natural gas-related emissions. New boilers would require permits from the Bay Area Air Quality Management District (“BAAQMD”) that would place conditions on emissions and annual operations.⁹

The District Energy variants may include a back-up diesel generator. These generators would be tested regularly, as are the existing emergency generators on Treasure Island. The resulting air pollutant emissions would be similar to those of the existing emergency generators, which would continue to be used under the Proposed Project.

Both Variants A2 and A3 would have similar operational air quality impacts as the Proposed Project, as discussed in Impact AQ-6 (operations), p. IV.G.42. As natural gas is relatively clean burning and the contribution of natural gas emission to overall project emissions is less than 6

⁹ See, e.g., BAAQMD, Regulation 8, Inorganic Gaseous Pollutants, Rule 11, Nitrogen Oxides and Carbon Monoxide from Electric Power Generating Steam Boilers, available at <http://www.baaqmd.gov/Divisions/Planning-and-Research/Rules-and-Regulations.aspx>, accessed June 19, 2010.

percent (refer to Table IV.G-5 of Section IV.G, Air Quality) the variation in natural gas combustion between these two variants and the Proposed Project would not result in a new or substantially increased or reduced impacts. Variants A2 and A3 would contribute to the cumulatively significant impact on air quality, as discussed in Impact AQ-9. See Section IV.G, Air Quality, at p. IV.G.52.

Greenhouse Gases

The impact on greenhouse gas emissions and climate change would not be significant, due to the extensive energy efficiencies and sustainable policies incorporated in these Variants, as discussed for the Proposed Project. Depending on the extent of resultant efficiency increases, it is likely that Variant A2 and possibly Variant A3 may result in a reduction of GHG emissions compared to the Proposed Project as a result in reduced natural gas demand and associated combustion.

Boilers would require a permit from the BAAQMD that would place conditions on emissions and annual operations. As permitted stationary sources, this equipment would be compared to a separate GHG threshold according to BAAQMD guidance.¹⁰ GHG emissions from stationary sources are to be calculated separately from a project's operational emissions because permitted stationary sources would be subject to a different threshold (10,000 Metric tons per year of eCO₂) than land use developments. Consequently, these variants would reduce the impact from the perspective of comparison to the BAAQMD's proposed GHG threshold for a land use project.

Because the Proposed Project does not propose any stationary sources, these variants would result in stationary source GHG impacts that would not occur under the Proposed Project. The potential for these variants to result in a GHG impact in excess of the proposed stationary source thresholds is unlikely. As indicated in Table IV.H.3 of Section IV.H, Greenhouse Gas Emissions, Proposed Project natural gas emissions are predicted to be 5,188 metric tons per year of eCO₂. Variant A2 would have natural gas demand less than the Proposed Project. Variant A3 could potentially have a greater natural gas demand than the Proposed Project to accommodate the electrical energy generation, but because of efficiencies associated with co-generation, this increased demand would be unlikely to increase the demand such that it would result in emissions greater than the proposed 10,000-metric-ton-per-year stationary source standard (to exceed this standard, demand would need to approximately double). Testing and maintenance of back-up generators is typically restricted to less than 60 hours per year by permit. Emissions from two generators would vary depending on the size and specifications of the generator; however, based on calculations conducted for other projects, would certainly be less than 100 metric tons per year. Based on the above analysis, it can be reasonably asserted that these two variants would not result

¹⁰ BAAQMD *California Environmental Quality Act Air Quality Guidelines*, June 2010, (hereinafter "BAAQMD Air Quality CEQA Guidelines") pp. 4-5. Available at: <http://www.baaqmd.gov/Divisions/Planning-and-Research/CEQA-GUIDELINES.aspx>.

in a significant stationary source GHG impact. Thus, Variants A2 and A3 would not change the conclusions in Section IV.H, Greenhouse Gas Emissions, for the Proposed Project.

Hydrology and Water Quality

Hydrology and water quality impacts under Energy Variants A2 and A3, including subvariants, would be the same as or similar to the environmental impacts addressed in Section IV.O, Hydrology and Water Quality, for the Proposed Project. The proposed heating/cooling plant, or the satellite plants, would be constructed within the planned urban corridor, and would not require additional construction activities as compared to the Proposed Project (reduction in needed construction for individual cooling systems would offset construction needed for district cooling). Similarly, the centralized heating/cooling plant, or the satellite plants, would not result in a substantial change in impervious surfaces or drainage.

For Variant A3, installation of a natural gas fired combustion turbine could require additional water usage, primarily for cooling water makeup. This additional water usage could be reduced in part by the use of dry cooling, or wet-dry cooling, as described for Subvariant A. Blowdown from cooling towers could also be increased for Variant A3, due to potentially increased cooling requirements in support of electricity generation. Cooling tower blowdown typically contains elevated levels of total dissolved solids, and may contain elevated levels of metals and other constituents. Cooling tower blowdown, and other plant process water would likely be discharged to the sanitary sewer system, and then treated and discharged by the wastewater treatment plant. This would not substantially alter water quality. Alternatively, plant discharge water could be discharged directly into the San Francisco Bay. This would require the applicant to acquire a facility-specific NPDES permit.¹¹ The Waste Discharge Requirements of that permit would include enforceable limits to pollutant discharge, such that water quality would not be substantially altered.

In summary, hydrology and water quality impacts resulting from operation of Energy Variants A2 and A3, including subvariants, would be less than significant as described in Section IV.O, Hydrology and Water Quality, for the Proposed Project, and would not change the analysis or conclusions in that Section.

Hazards and Hazardous Materials

Hazards and hazardous materials impacts under Energy Variants A2 and A3, including subvariants, would be the same as or similar to the environmental impacts addressed in

¹¹ U.S. Environmental Protection Agency, Office of Wastewater Management, Water Permitting, "Water Permitting 101," a PDF file, available at <http://www.epa.gov/npdes/pubs/101pape.pdf>, accessed on June 19, 2010, p. 6, stating that discharge into a wetland, which is considered a "water of the United States," requires an NPDES permit. The San Francisco Bay is also a "water of the United States."

Section IV.P, Hazards and Hazardous Materials, for the Proposed Project. The District Energy variants may include a back-up diesel generator and an aboveground diesel fuel storage tank for it. The diesel fuel storage tank would be similar to the existing diesel fuel storage tanks on Treasure Island, which would continue to be used. Although there would be some additional risk with additional flammables on Treasure Island, aboveground diesel fuel storage tanks are built to withstand shocks, including earthquakes, and are generally considered to have less potential risks associated with them than underground storage tanks. Any increased risk of fuel spills or fire would not be significant. Therefore, the Proposed Project's environmental impacts related to hazards and hazardous materials under Energy Variants A2 and A3, including subvariants, would be less than significant, as described in Section IV.P, Hazards and Hazardous Materials, for the Proposed Project, and would not change the conclusions or mitigation identified there.

Mineral and Energy Resources

Environmental impacts associated with mineral and energy resources under Energy Variants A2 and A3, including subvariants, would be the same as or similar to the environmental impacts addressed in Section IV.Q, Mineral and Energy Resources, for the Proposed Project. Variant A2 would likely burn less natural gas than the Proposed Project, because the centralized (and/or satellite) plants would be more efficient, and would burn less natural gas than individual boilers in buildings under the Proposed Project. Variant A3, which would generate electricity, would tend to shift Treasure Island's energy consumption from electricity to natural gas.¹² This is because the on-site electricity generation would use natural gas as fuel, and would offset the consumption of electricity from non-island sources, which are based on a wider variety of fuels and resources.

Therefore, the Proposed Project's environmental impacts associated with mineral and energy resources under Energy Variants A2 and A3, including subvariants, would be less than significant as described in Section IV.Q, Mineral and Energy Resources, for the Proposed Project, and would not change the analysis or conclusions there.

Other Topics

The analysis of impacts in the areas of population and housing, archaeological and paleontological resources, architectural resources, transportation, wind and shadow, recreation, other utilities (water, wastewater, stormwater, solid waste), public services, biological resources, geology and soils, mineral resources, and agricultural resources and forest land would be the same with Variants A2 and A3 as with the Proposed Project.

¹² 2009 Energy Study, pp. 43-47.

B. FERRY TERMINAL BREAKWATER VARIANTS

DESCRIPTION

In addition to the Ferry Terminal configuration described in Chapter II, Project Description, and analyzed in Chapter IV, Environmental Setting and Impacts, three other breakwater configurations were considered. Breakwater Variant B1 would provide for symmetrical angled breakwaters, each extending the same distance from the land connection. Breakwater Variant B2 would include two symmetrical angled breakwaters extending from the land connection plus a third, detached breakwater on the north side of the Ferry Terminal extending further into the Bay at an oblique angle. General configurations for each of these Breakwater Variants are shown in Figure VI.3: Ferry Terminal Breakwater Variant B1, Figure VI.4: Ferry Terminal Breakwater Variant B2, and Figure VI.5: Ferry Terminal Breakwater Variant B3. Breakwater Variant B3 would have the same configuration as in the Proposed Project (see Figure II.8 in Chapter II), but the northern breakwater would be constructed first as part of building the Ferry Terminal, and the southern breakwater would be constructed in a later phase.

Variants B1 and B2 were selected because they provide alternative harbor configurations that could create slightly different wave conditions within the harbor. These variants, as well as the Proposed Project, were developed through a study conducted by the Water Emergency Transit Authority (“WETA”). The preliminary results of WETA’s analysis are that the Proposed Project configuration would be the best from an operational perspective. However, as part of detailed design, studies would be done that would refine the operational analysis, and it is possible that they could show that Variant B1 or B2 could offer operational benefits. Therefore, Variants B1 and B2 are analyzed here.

Variant B3 was selected for analysis in the event that the Proposed Project’s configuration (or that of Variants B1 or B2), which requires substantial infrastructure investment, was determined to be financially infeasible. In that instance, phasing of Ferry Terminal construction would be desired. Variant B3 analyzes the impacts of phasing construction, as well as using side-loading vessels. The Proposed Project and Variants B1 and B2 all rely on bow-loading vessels. The existing San Francisco docking facilities are all configured for side-loading vessels; the Treasure Island bow-loading vessels would be designed to permit both side- and bow-loading operations, so that they could be used with those facilities. However, a true side-loading vessel would operate more smoothly if used with the existing San Francisco docking facilities

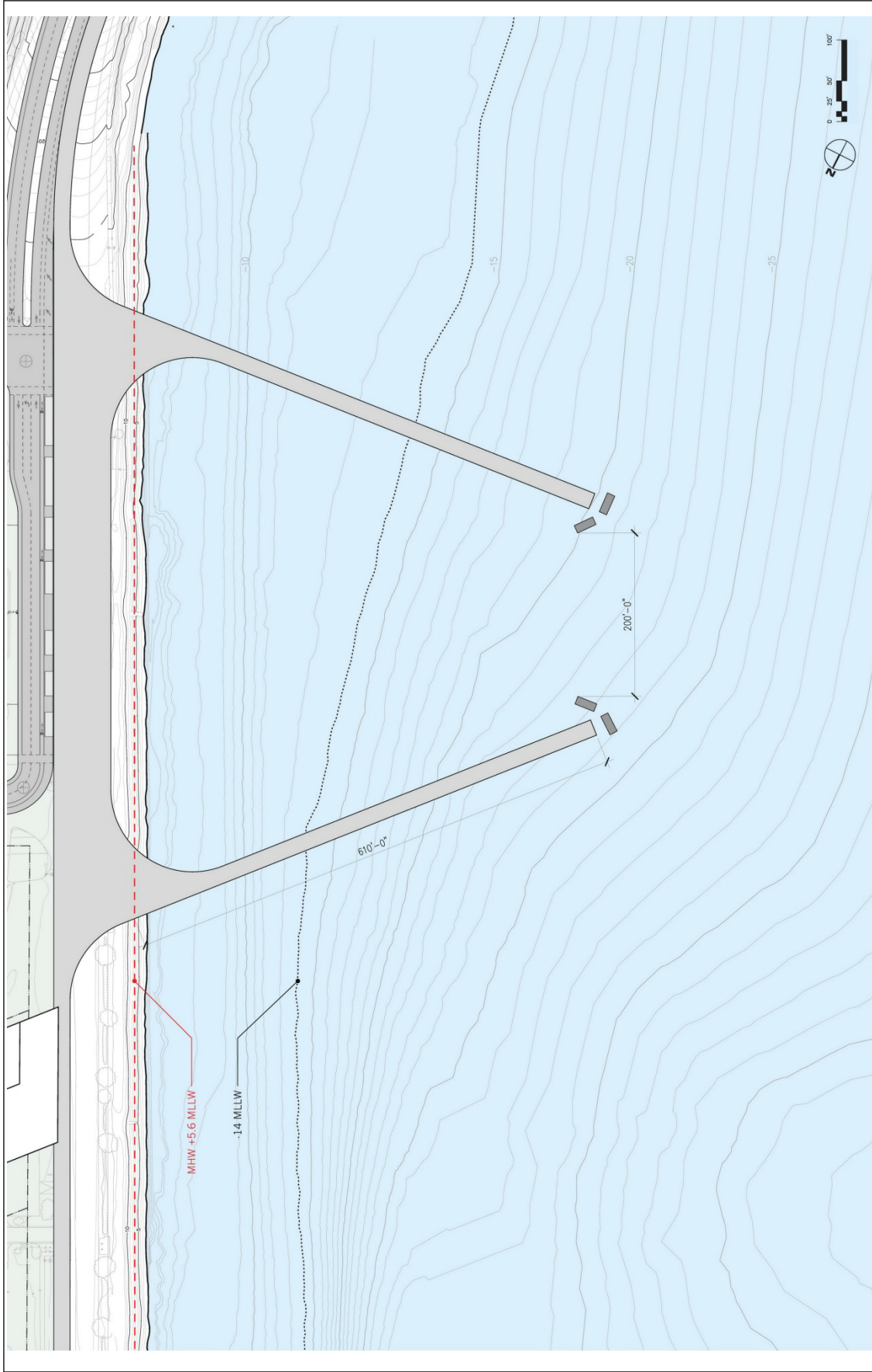

SOURCE: Mofatt & Nichol

TREASURE ISLAND AND TERBA DUEÑA ISLAND REDEVELOPMENT PROJECT EIR

FIGURE VI.3: FERRY TERMINAL BREAKWATER VARIANT B1

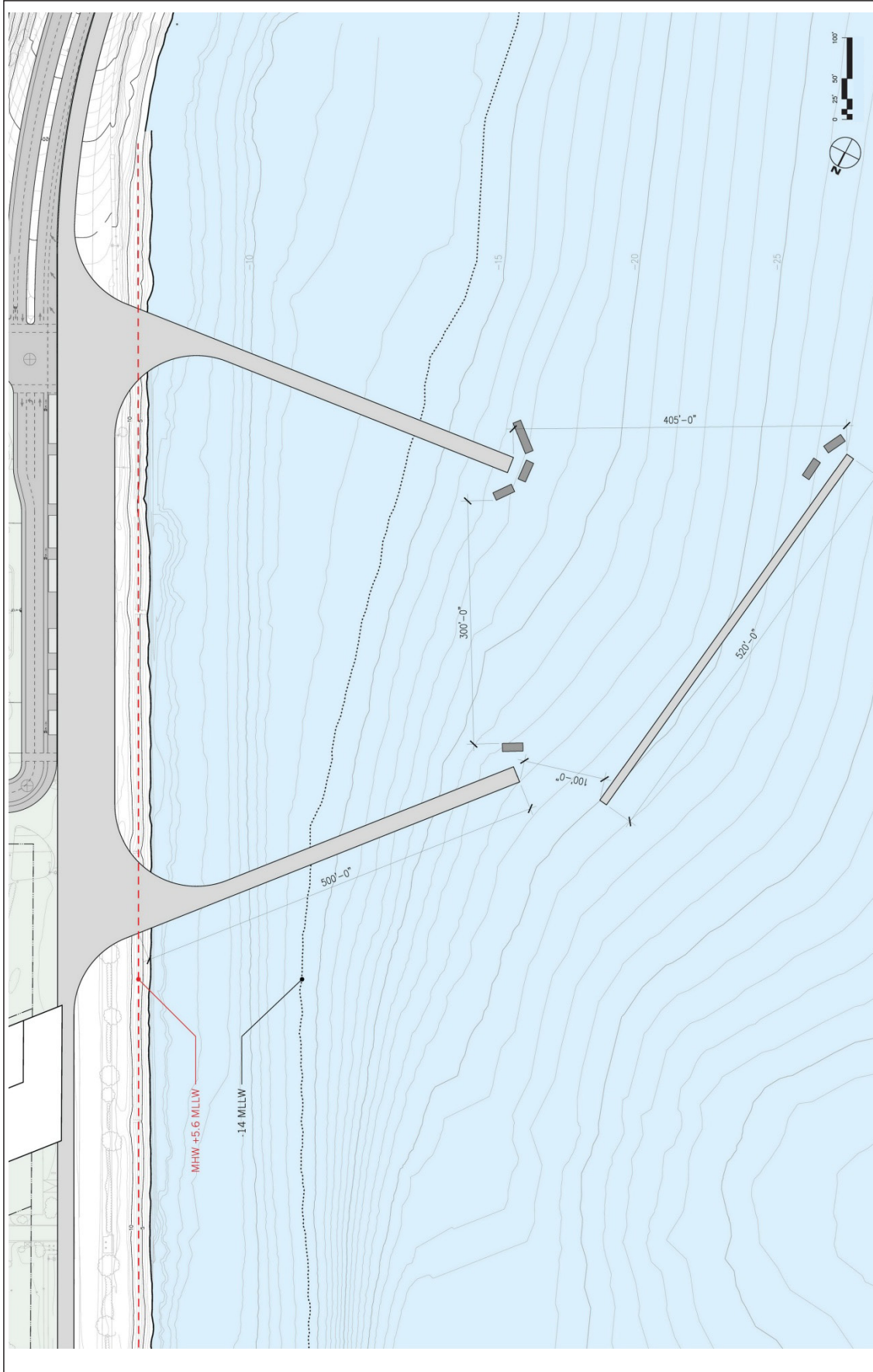

SOURCE: Mofatt & Nichol

TREASURE ISLAND AND TERBA DUEÑA ISLAND REDEVELOPMENT PROJECT EIR

FIGURE VI.4: FERRY TERMINAL BREAKWATER VARIANT B2

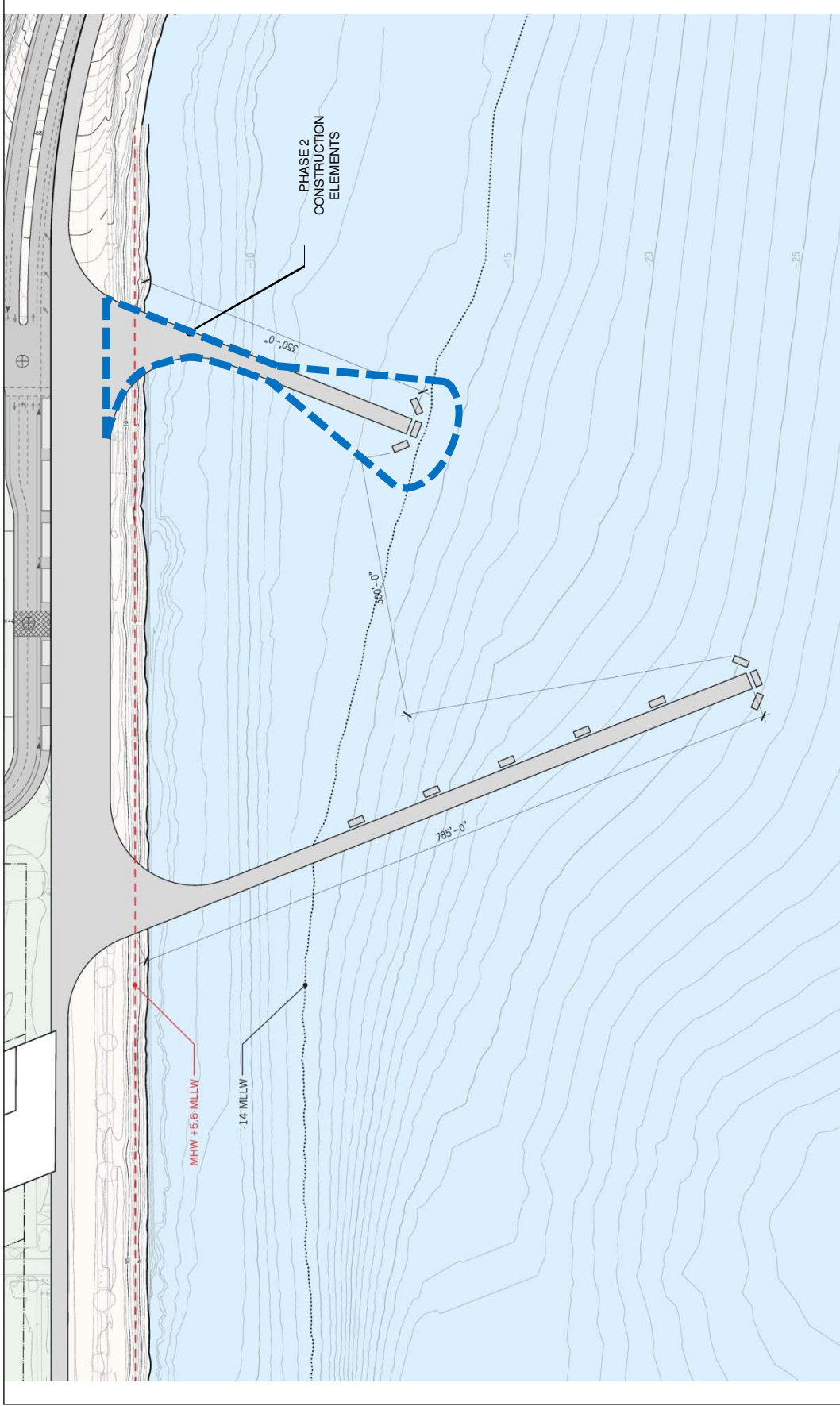

Note: All other waterside work to be completed in Phase 1

Work to be completed in Phase 2

SOURCE: Mofatt & Nichol

TREASURE ISLAND AND TERBA PUENA ISLAND REDEVELOPMENT PROJECT EIR

FIGURE VI.5: FERRY TERMINAL BREAKWATER VARIANT B3

The symmetrical breakwater design, Breakwater Variant B1, would have two angled breakwaters extending about 600 feet from the shore, providing a 200-foot-wide harbor opening. The harbor opening would be directly west of the shoreline and the ferry berths. Breakwater Variant B2 would have two shorter angled breakwaters extending about 500 feet from the shore, with a harbor opening of about 300 feet, plus a third, detached breakwater. The third structure would be about 100 feet from the northern angled breakwater and would extend about 520 feet to the southwest, resulting a distance of about 400 feet from the end of the southern angled breakwater. The harbor opening would face south rather than west as a result of the third structure. In both variants the breakwaters would be constructed of the same materials as for the Proposed Project, using the same construction methods.

Breakwater Variant B3 would construct the breakwaters for the Ferry Terminal in two phases. Phase One of the Breakwater Variant B3 would include only the northern breakwater (about 800 feet long); the southern breakwater (about 450 feet long) would be constructed in a second phase, about 7 to 10 years later. Phase One would also include the edge treatments, buildings, passenger queuing and waiting areas, and the access pier and gangway as described for the Proposed Project. The access pier and gangway would be narrower than the 28-foot-wide transfer spans providing access to the bow-loading ferries described for the Proposed Project. A boarding float would provide two slips for berthing side-loading ferry vessels, rather than bow-loading vessels. The boarding float would be approximately 115 feet long by 45 feet wide, larger than the single float in the Proposed Project (70 by 30 feet) intended to accommodate the occasional side-loading ferry. The side-loading ferries would carry fewer passengers than the bow-loading ferries described for the Proposed Project, at approximately 149 to 399 passengers rather than up to 699 passengers.

IMPACT EVALUATION

Aesthetics

Aesthetics impacts under Variants B1, B2 and B3 would be the same as or similar to those addressed in Section IV.B, Aesthetics, for the Proposed Project, except as described here. The Breakwater Variants would look slightly different when viewed from the Bay compared to the Proposed Project; however, none of the Breakwater Variants would result in a significant adverse change in views. Long-range views of the Proposed Project from San Francisco, including views from Telegraph Hill and Rincon Park, would not change substantially with any of the Breakwater Variants. Therefore, these variants would not result in new significant aesthetic impacts, and the analysis or conclusions in Section IV.B, Aesthetics, for the Proposed Project, would not be changed under Variants B1, B2 and B3.

Transportation

Breakwater Variants B1 and B2 would provide similar docking facilities for large, bow-loading ferries with capacities of up to 699 passengers. Therefore, there would be no changes in transportation impacts compared to the Proposed Project.

Breakwater Variant B3 would accommodate smaller, side-loading ferry vessels, with capacities ranging from 149 to 399 passengers. The capacity available on ferry transit service with Variant B3 would be substantially less than that of the Proposed Project, with a total capacity of up to 399 passengers every 50 minutes, compared to the Proposed Project with up to 699 passengers. As presented in Section IV.E, Transportation, the Proposed Project would generate about 480 ferry riders in the peak direction in the weekday PM peak hour, which is the greatest demand for ferry service. With approximately one ferry per hour, this variant might not provide sufficient capacity to serve the demand, depending on the size of the boat selected. However it is reasonable to assume the largest possible boat would be used if demand warranted. It is reasonable to assume that the majority of the approximately 80 passengers not served by the ferry during the PM peak hour would instead use buses to commute to and from the Islands. As the Proposed Project would result in significant capacity impacts on bus transit (see Impact TR-19 in Section IV.E, Transportation, p.IV.E.95), Variant B3 could slightly exacerbate this significant transit impact.

Mitigation Measure M-TR-2, p. IV.E.74, would provide for three ferry boats rather than only one, with one ferry every 15 minutes. This would provide a capacity of between 600 passengers and 1,600 passengers in each direction, and would more than accommodate the demand estimated in the transportation analysis. Therefore, the impact of this variant would be less than significant with adoption of Mitigation Measure M-TR-2. As explained in the discussion of Mitigation Measure M-TR-2, because the funding for three ferry vessels cannot be assured and associated impacts on transit as a result of a potential mode shift from Ferry to buses, the impact would remain significant and unavoidable.

Based on this analysis, the analysis and conclusions presented in Section IV.E, Transportation, and the mitigation measures identified there, would not be changed with implementation of Variants B1, B2, or B3.

Noise

Construction noise would generally be the same for the three Breakwater Variants as for the Proposed Project. Variant B3 would construct the breakwater into two phases, unlike the Proposed Project and other variants. This would extend the duration of pile driving for Variant B3, although the total number of days of pile driving would be the same. However, pile driving would be occurring around the Island for all phases of construction, and this temporal extension

of pile driving activity would be consistent with the significant unavoidable noise impact identified in Section F. Noise, p. IV.F.17.

Operational noise would be expected to be similar for Variants B1 and B2 as for the Proposed Project. Variant B3 would result in the use of smaller ferries which could have smaller and therefore, quieter engines than the larger ferry of the Proposed Project. Operational noise from ferries is identified as a less than significant impact with adoption of Mitigation Measure M-NO-4, and this impact could be slightly further reduced by selection of Variant B3.

In summary, the analysis and conclusions presented in Section IV.F, Noise, for the Proposed Project, and mitigation measures identified there, would not be changed with implementation of Variants B1, B2, or B3.

Air Quality

Construction air quality impacts would generally be the same for the three Breakwater Variants as for the Proposed Project. Variant B3 would construct the breakwater in two phases, unlike the Proposed Project and other variants. This would extend the duration of construction for Variant B3. However, construction activities would be occurring around the Island for all phases of construction, and this temporal extension of activity would be consistent with the significant unavoidable air quality impact identified in Section G, Air Quality. The same mitigation measures as identified for the Proposed Project would apply to these variants during construction.

Operational air quality impacts would also be expected to be the same for Variants B1 and B2 as for the Proposed Project. However, Variant B3 would result in the use of a smaller ferry, which would have a fuel demand 80 percent less than that assumed for the Proposed Project¹³ or other variants. Consequently, Variant B3 would reduce total NOx emissions from 457 pounds per day under the Proposed Project to 225 pounds per day. The NOx air quality impact would remain significant and unavoidable under Variant B3 but the magnitude of this impact would be substantially reduced. While emissions of ROG and PM₁₀ would also represent a significant and unavoidable impact under the Proposed Project, these pollutants are not substantially emitted by ferries and, therefore, reductions of ferry emissions under Variant B3 would not be as pronounced as reductions of NOx emissions.

Therefore, the analysis and conclusions, and the mitigation measures identified in Section IV.G, Air Quality, for the Proposed Project, would be similar to those under Variants B1, B2 and B3. No new significant impacts would result, and no significant impacts would be reduced to less-than-significant levels.

¹³ Elliott Bay Design Group, Memorandum from John Waterhouse, March 29, 2010 (hereinafter "Elliott Bay Design Group, 2010"). A copy of this document is available for public review at the San Francisco Planning Department, 1650 Mission Street, Suite 400, in Case File No. 2007.0903E.

Greenhouse Gases

Construction GHG impacts would generally be the same for the three Breakwater Variants as for the Proposed Project. Although Variant B3 would construct the breakwater in two phases, GHG impacts are addressed in terms of annual emissions. Further, neither the BAAQMD nor any other regulatory agency has adopted or proposed GHG significance thresholds relative to construction emissions. Consequently, construction related GHG emissions of the three Breakwater Variants are considered to be the same as those identified for the Proposed Project.

Operational GHG impacts would also be expected to be the same for Variants B1 and B2 as for the Proposed Project. However, Variant B3 would result in the use of a smaller ferry vessel, which would have a fuel demand 80 percent less than that assumed for the Proposed Project¹⁴ or other variants. Consequently, Variant B3 would reduce GHG emissions by about 2,597 metric tons per year of CO₂e as compared to the Proposed Project. The GHG impact would remain less than significant under Variant B3, and the magnitude of this impact would be substantially reduced.

Therefore, the analysis and conclusions in Section IV.H, Greenhouse Gas Emissions, for the Proposed Project would not change under Variants B1, B2, and B3.

Biological Resources

Potential effects on marine habitat and associated flora and fauna from the Breakwater Variants are expected to be similar in nature and severity of effect to those of the Proposed Project, with one potential exception for Variant B3 that is discussed below. As discussed in Section IV.M, Biological Resources, the principal potential impacts on the marine environment from construction and operation of the new Treasure Island Ferry Terminal include:

- Loss and alteration to shoreline rocky intertidal habitat along the eastern side of the Ferry Terminal with concurrent reduction in associated intertidal biota,
- Loss and alteration of nearshore subtidal soft bottom habitat under the footprint of the Ferry Terminal breakwater, in the dredged terminal, and to the south and possibly to the north of the breakwater,
- The addition of artificial hard bottom higher relief habitat from the breakwater,
- Temporary deterioration of water quality during dredging operations and from ferry propeller wash,
- Temporary disturbance to sensitive or protected marine mammals and fish from high decibel noise during pile driving,
- Temporary increased exposure to resuspended contaminated sediments during dredging and construction activities,

¹⁴ Elliott Bay Design Group, 2010.

- Altered fish foraging benthic habitat resulting from altered energy regime and the deposition of sediments south and possibly north of the breakwater,
- Increased exposure to accidentally spilled hydrocarbons (fuel, lubricating oils, hydraulic fluids, etc.) from the use of additional ferries and increased ferry trips to support the Treasure Island ferry route, and
- Increased nighttime illumination of Bay waters and air from artificial lighting at the Ferry Terminal.

The Ferry Terminal harbor design that is part of the Proposed Project and the three Breakwater Variants would all involve similar construction and operational activities and require comparable times for construction to full buildout. The ferry quay and breakwater in the Proposed Project and Variants B1 and B2 would be completely constructed in one phase, whereas Variant B3 would be the same design as the Proposed Project but would be constructed in two phases, with the time between construction of the two phases being 7 to 10 years.¹⁵

All variants, at buildout, would require identical volumes of material to be dredged, have the same shoreline footprint, and have comparable losses in habitat under the proposed new breakwater.^{16,17} The geographic area of marine habitat potentially affected is slightly less with Variant B1 than with Variants B2, B3, and the Proposed Project.^{18,19}

Resultant alterations or effects on marine habitats and associated biota from construction at buildout are expected to be similar for all variants to those presented in Section IV.M, Biological Resources, and implementation of the mitigation measures identified for the Proposed Project would be applicable to all Breakwater Variants. These mitigation measures would be expected to reduce impacts to less-than-significant levels. The potential for significant impacts to sensitive and protected aquatic vegetation beds (*Zostera spp.*), marine mammals, protected fish species, and marine communities during construction of the second breakwater in Variant B3 may result in the need for similar mitigation measures, including M-BI-1e for monitoring during off-shore pile driving, and M-BI-2 related to protecting submerged aquatic vegetation, to be carried out again at that time.

¹⁵ Moffatt and Nichol. 2010. Treasure Island Ferry Terminal – Side Loading Ferry Terminal Variant; Memorandum to Alexandra Galovich, April 6, 2010 (hereinafter “Moffatt and Nichol, 2010”). A copy of this document is available for public review at the San Francisco Planning Department, 1650 Mission Street, Suite 400, in Case File No. 2007.0903E.

¹⁶ Moffatt and Nichol, 2009 Moffatt and Nichol,. *Treasure Island Ferry Terminal Project, Coastal Engineering Assessment*. September, 2009 (“Moffatt and Nichol, 2009”) A copy of this document is available for public review at the San Francisco Planning Department, 1650 Mission Street, Suite 400, in Case File No. 2007.0903E.

¹⁷ Moffatt and Nichol, 2010

¹⁸ Moffatt and Nichol, 2009

¹⁹ Moffatt and Nichol, 2010

With the exception of potentially significant impacts on future eelgrass beds and marine mammal utilization of the area resulting from Variant B3's delayed construction schedule for the southern breakwater, the conclusions and mitigation identified in Section IV.M, Biology, for the Proposed Project, would be similar to those under Variants B1, B2 and B3.

Impact BI-8 (Variant B3): For Variant B3, delayed construction of the southern breakwater could result in adverse impacts on sensitive species, such as protected eelgrass beds, protected marine mammals, or protected fish species that are not currently present in or known to frequent the area, but could establish themselves there by the time the southern breakwater is constructed. (*Less than Significant with Mitigation*)

One consequence of delayed construction of the southern breakwater is that over the intervening time period (7 to 10 years after construction of the northern breakwater), baseline conditions for the marine environment offshore Treasure Island and Yerba Buena Island may change from the conditions studied in this environmental analysis. For example, as a result of the reduced energy environment along the southern shoreline of Treasure Island resulting from the construction of the Ferry Terminal's north breakwater, eelgrass (*Zostera spp.*) beds could become established or harbor seals (*Phoca vitulina richardsi*) could establish a new haul-out site along the western shore of Treasure Island that would then be affected by the construction of the southern breakwater. Because of the delayed construction schedule, construction of the southern breakwater could result in a significant impact on sensitive, protected eelgrass beds, protected marine mammals, or protected fish species such as green sturgeon (*Acipenser medirostris*) that are not currently present in or known to frequent the area, but could be there by the time the southern breakwater is constructed. It is not possible to reliably define the potential for impact and the magnitude of that impact at this time. If, at the time of construction of the southern breakwater, site conditions and the presence and/or use of the area by sensitive and protected species, specifically eelgrass or marine mammals, have substantially changed from the site conditions evaluated in this EIR, the potential impact from the delayed construction of the southern breakwater in Variant B3 would be considered significant.

Mitigation Measure M-BI-8 (Variant B3): Minimize Disturbance to Newly Established Sensitive Species During Construction of Southern Breakwater

If Variant B3 is selected as the preferred Ferry Terminal breakwater approach, prior to initiation of any construction activities for the southern breakwater, a survey of the construction area shall be conducted by a qualified marine biologist to assess the presence of eelgrass (*Zostera spp.*) beds, green sturgeon or other protected fish species, and utilization by marine mammals, primarily harbor seals (*Phoca vitulina*) and California sea lions (*Zalophus californianus*). Survey results will be submitted to TIDA, and by TIDA to the ACOE, BCDC, NMFS, and CDFG.

In the event the survey shows that eelgrass (*Zostera spp.*) has established beds within the proposed construction area of the southern breakwater or within close proximity, such that

planned construction activities could have an impact on the beds, then the restoration of offsite eelgrass beds or the transplantation and establishment of offsite or onsite eelgrass beds at a replacement ratio of 3:1 will be made.

In the event the survey shows that the planned establishment or construction of the southern breakwater would affect utilization of the area by protected fish species or by marine mammals as a haul-out area, construction and establishment of the southern breakwater will be done, under consultation with National Marine Fisheries, in a manner that does not adversely affect the protected fish species or prevent the continued utilization of the area by harbor seals or sea lions.

Hydrology and Water Quality

Moffatt and Nichol²⁰ completed an assessment of wave penetration/reflection, swell, harbor resonance, and sedimentation in support of Variants B1-B3. The following compares each variant in terms of wave penetration, swell, resonance, and sedimentation.

Wave Penetration: Variant B1 would have symmetrical angled breakwaters, and wave penetration under this variant would be greatest when waves approach from the west, from the direction of the San Francisco mainland. Wave heights of up to one foot inside the harbor could occur several times per year. For Variants B2 and B3, wave penetration into the harbor would be greatest for waves from the south, consistent with orientation of the entrance channel. For Variant B2, wave heights of up to half a foot could occur approximately once per year. For Variant B3, wave heights of at least one foot could occur several times per year, both before and after installation of the southern breakwater, as for the Proposed Project.

Swell: Swell derived from the Pacific Ocean could affect the Ferry Terminal harbor. The Moffatt and Nichol report indicates that swell would be minor for all three Breakwater Variants. Swell would be the least for Variant B2, and most for Variant B3, until the southern breakwater is installed, with Variant B1 being intermediary. Following installation of the southern breakwater, swell for Variant B3 would be the same as the Proposed Project and more similar to, but still greater than, Variant B1.

Harbor Resonance: Resonance waves could potentially be generated within the ferry basin. The Moffatt and Nichol report indicates that substantial infragravity resonance waves²¹ would not be generated under any of the variants or the Proposed Project. Resonance associated with Pacific

²⁰ Moffatt and Nichol, 2009

²¹ An infragravity wave is a long-period, waterborne wave that is generated along coastlines by incoming ocean swells. Infragravity waves are generally defined as having a period of longer than 30 seconds. In the context of the Proposed Project, resonance refers to the tendency of the ferry basin area to propagate waves of some frequencies at a higher amplitude (e.g., a taller wave) than other frequencies. The concern here is whether an incoming swell having a particular frequency could cause an unexpectedly large standing wave to form inside the harbor.

Ocean derived swell is also expected to be insignificant for all variants. At most, these resonance waves could produce a swell of up to 0.6 foot under all variants, and this amount would not be significant.

Sedimentation: For Variant B1 and Variant B3 following installation of the southern breakwater, sedimentation within the harbor would be minor, as for the Proposed Project. Under Variant B2 and the first phase of Variant B3, sedimentation in the harbor would be relatively increased compared to the Proposed Project. For these two variants, sedimentation would occur during ebb tide, flow would be directed into the harbor, which may result in sedimentation near the harbor entrance. Therefore, under Variant B2 and the first phase of Variant B3, relatively increased dredging operations may be required. These increased dredging operations would be completed pursuant to the permits and procedure discussed in Section IV.O, Hydrology and Water Quality, and therefore would be similar to the Proposed Project, and would result in a less-than-significant impact on water quality.

Although Variants B1, B2, and B3 would result in minor differences associated with wave penetration, swell, resonance, and sedimentation, these differences would result in relatively minor effects on hydrologic resources and water quality, and would remain similar to those discussed in Section IV.O. No mitigation measures would be required, as for Ferry Terminal construction and operation with the Proposed Project.

Other Topics

The Ferry Terminal Breakwater Variants would have no impacts different from the Proposed Project in the areas of land use, population and housing, archaeological and paleontological resources, architectural resources, wind and shadow, recreation, utilities and service systems, public services, geology and soils, hazards and hazardous materials, mineral and energy resources, or agricultural resources and forest land.

C. SUPPLEMENTAL FIREFIGHTING WATER SUPPLY VARIANTS

DESCRIPTION

Two variants to the Supplemental Firefighting Water System are under consideration by project sponsors: Supplemental Firefighting Water Supply Variant C1 (“Supplemental Water Variant C1”) would use potable water by installing additional storage and pumping facilities on Treasure Island; and Supplemental Firefighting Water Supply Variant C2 (“Supplemental Water Variant C2”) would use Bay water by installing a pump station with a saltwater intake pipe and suction hydrants located around the perimeter, and a firefighting water distribution system with hydrants

on Treasure Island. As with the Proposed Project, two fire boat manifolds and two suction hydrants would be installed along the southern shore of Treasure Island and near Pier 1 and the Ferry Terminal as part of Supplemental Water Variant C1. Variant C2 would include these features, but link them to a network of distribution pipes and hydrants. Both variants would reduce the size of the recycled water tank proposed as part of the Proposed Project, from 1.26 million gallons to approximately 420,000 gallons.

Variants C1 and C2 would provide a supplemental firefighting water supply that would be comparable to that of the Proposed Project. The recycled water system included in the Proposed Project was preliminarily identified as preferable by the San Francisco Fire Department. The rationale for this was that Variant C1, which would locate domestic water storage on Treasure Island, would require more routine pumping of domestic water than the Proposed Project, which relies heavily on gravity pressure from the higher tanks on YBI, as well as concerns about staleness of water stored in domestic tanks at an end-point in the distribution network. The pumping would add to the operating costs of the system. Variant C2 was not identified as the preferred approach because there were concerns that salt water in the system intakes, pipes and equipment could cause greater organic and inorganic buildup and corrosion than recycled water, increasing long-term maintenance and replacement costs of the system.

Supplemental Water Variant C1 would include a 1.84 million gallon circular steel or concrete storage tank on Treasure Island in the vicinity of the wastewater treatment plant. It would be approximately 105 feet in diameter and 30 feet tall and would store potable water. With this volume of storage on Treasure Island, the potable water storage tanks on Yerba Buena Island would be reduced by 1 million gallons to a total of 3.0 million gallons, resulting in an overall increase in storage on the Islands of about 840,000 gallons. A pump station and back-up diesel generator would also be constructed on Treasure Island near the water storage tank. Some 8-inch water mains would need to be increased to 12-inch mains to allow delivery of fire flow and domestic water at normal domestic water pressure. Several pressure sustaining and/or pressure reducing valves also would be installed. The recycled water tanks on Treasure Island would be reduced by 840,000 gallons under Variant C1, and the recycled distribution system would be revised to provide minimum pressures and flows, as required for irrigation and commercial uses. The recycled water fire hydrants would also be removed.

Supplemental Firefighting Water Variant C2 would consist of a pump station with a saltwater intake pipe; a main trunk line distribution piping system connected to the pump station, which in turn would be connected to up to 29 fire hydrants and facilities to connect to fireboats; and up to 3 suction hydrants located around the perimeter of Treasure Island. The fireboat connections would be located on either side of Treasure Island, near the Ferry Terminal and near Pier 1. Supplemental Water Variant C2 would have a diesel emergency power generator and additional pumps to provide redundancy during an emergency. The saltwater intake pipe extending into the

water would have a trash screen and may have a retractable fish screen where the pipe connects with the pump. The three suction hydrants would allow fire trucks to draw water directly from the Bay. These three hydrants would not be connected to the firefighting distribution piping and hydrants. The diesel generator and pump facilities would be tested regularly. The recycled water tanks on Treasure Island would be reduced by 840,000 gallons under Variant C2, and the recycled distribution system would be revised to provide minimum pressures and flows, as required for irrigation and commercial uses. The recycled water fire hydrants would also be removed.

IMPACT EVALUATION

Land Use

Land use impacts under Supplemental Firefighting Water Supply Variants C1 and C2 would be the same as or similar to the environmental impacts addressed in Section IV.A, Land Use and Land Use Planning, for the Proposed Project, except as described here.

The additional water tank and back-up generator for Supplemental Firefighting Water Supply Variant C1 would not have a land use impact, because they would be located in the wastewater treatment plant area, and would not be an incompatible land use. The pump station and back-up generator for Supplemental Firefighting Water Supply Variant C2 would be located in a small, one-story building on the southern shoreline of Treasure Island, between Buildings 2 and 3. It would be located in a primarily commercial area, and would not disrupt or divide the Eastside District neighborhood. Neither Variant would result in new significant land use impacts.

In summary, land use impacts under Supplemental Firefighting Water Supply Variants C1 and C2 would be less than significant, as described in Section IV.A, Land Use and Land Use Planning, for the Proposed Project, and would not change the analysis or conclusions presented there.

Aesthetics

Aesthetics impacts under Supplemental Firefighting Water Supply Variants C1 and C2 would be the same as or similar to the environmental impacts addressed in Section IV.B, Aesthetics, for the Proposed Project, except as described below.

The additional water tank and back-up generator for Supplemental Firefighting Water Supply Variant C1 would be approximately 105 feet in diameter and 30 feet tall. It would be near the wastewater treatment plant and therefore, in kind with surrounding structures. The back-up generator would be a smaller piece of equipment, similar to other pieces of industrial equipment in the vicinity of the treatment plant, and thus would not be noticeable from adjacent land uses. The pump station and back-up generator for Variant C2 would appear as a small industrial building in the commercial area around Buildings 2 and 3. The recycled water tanks on Treasure

Island would be reduced in size under Variant C1. These changes would not significantly change views of Clipper Cove or the historic buildings compared to the Proposed Project, and would blend with the proposed new buildings in the vicinity. They would not be visible from long-distance viewpoints, as with the Proposed Project. Neither supplemental firefighting water supply variant would result in new significant visual impacts.

In summary, aesthetic impacts under Supplemental Firefighting Water Supply Variants C1 and C2 would be less than significant as described in Section IV.B, Aesthetics, for the Proposed Project, and would not change the analysis or conclusions of that section.

Noise

Noise impacts under Supplemental Firefighting Water Supply Variants C1 and C2 would be the same as or similar to the environmental impacts addressed in Section IV.F, Noise, for the Proposed Project, except as described here.

Construction of the supplemental firefighting water supply facilities for Variants C1 and C2 would cause temporary noise impacts. The construction noise levels would be similar to that discussed in Section IV.F, Noise, for the Proposed Project, and would not change the significance conclusions. Mitigation Measures M-NO-1a and M-NO-1b, pp. IV.F.16 – IV.F.17, would decrease construction noise levels by requiring construction contractors to implement noise reduction measures for construction activities. Therefore, with implementation of the mitigation measures identified in Section IV.F, Noise, construction noise impacts would be reduced to less-than-significant levels, as for the Proposed Project.

Both Variants C1 and C2 would include a back-up diesel generator and pump stations. Noise shielding would be installed as necessary to comply with the San Francisco Noise Ordinance. The noise from the additional generator would not be different in kind or frequency than noise from the existing two back-up diesel generators that would continue to be used under the Proposed Project. While there would be an increase in noise during intermittent periods of generator maintenance, the additional generator would be located either at the wastewater treatment plant area (Variant C1) or at the pump station (Variant C2). Neither location would substantially increase a cumulative noise impact. Therefore, no significant noise impacts are anticipated.

In summary, noise impacts under Supplemental Firefighting Water Supply Variants C1 and C2 would be reduced to less than significant levels with adoption of mitigation measures as described in Section IV.F, Noise, for the Proposed Project, and would not change the conclusions or mitigation measures identified there.

Air Quality

Air quality impacts under Supplemental Firefighting Water Supply Variants C1 and C2 would be the same as or similar to the environmental impacts addressed in Section IV.G, Air Quality, for the Proposed Project, except as described here.

Installation of the facilities would result in construction dust and equipment and truck emissions. These air quality impacts would be similar to those described Section IV.G, Air Quality, Impacts AQ-1 through AQ-4, for the Proposed Project, and would not change the significance analysis. The same mitigation measures, M-AQ-1, M-AQ-2, and M-AQ-4, pp. IV.G.26 - IV.G.38, would apply.

The additional back-up diesel generator under Variants C1 and C2 would emit air pollutants during weekly testing and during emergency use, similar to the two existing back-up generators that would continue to be used under the Proposed Project. The additional generator would incrementally add to the emissions of criteria pollutants and diesel particulate matter, which is a toxic air contaminant. The back-up diesel generator would require a permit from the Bay Area Air Quality Management District, which would place conditions on emissions and annual operations. The impact analysis and mitigation measures for operation, as described in Section IV.G, Air Quality, would apply, and no new significant impacts would result compared to the Proposed Project.

In summary, air quality impacts under Supplemental Firefighting Water Supply Variants C1 and C2 would remain significant, even with adoption of mitigation measures described in Section IV.G, Air Quality, for the Proposed Project. Including either of the supplemental firefighting Water Supply Variants in the Proposed Project would not change the analysis and conclusions or mitigation measures identified for the Proposed Project.

Greenhouse Gases

Greenhouse Gas emission impacts under Supplemental Firefighting Water Supply Variants C1 and C2 would be the same as or similar to the environmental impacts addressed in Section IV.H, Greenhouse Gas Emissions, for the Proposed Project, except as described here.

Installation of the facilities would result in construction equipment and truck GHG emissions. These GHG impacts would be similar to those described Section IV.H, Greenhouse Gas Emissions.

The operational impact on greenhouse gas emissions and climate change would not be significant, as once water is initially pumped into storage vessels, further pumping would not be required except for emergency use and maintenance.

The back-up diesel generator would require a permit from the Bay Area Air Quality Management District, which would place conditions on emissions and annual operations. As a permitted stationary source, this equipment would be compared to a separate GHG threshold according to proposed BAAQMD Guidance.²² GHG emissions from stationary sources are to be calculated separately from a project's operational emissions because permitted stationary sources would be subject to a different threshold (10,000 Metric tons per year of CO₂e) than land use developments.

Testing and maintenance of back-up generators is typically restricted to less than 60 hours per year by permit. Emissions from a single generator would vary depending on the size and specifications of the generator, however, based on calculations conducted for other projects, GHG emissions would certainly be less than 50 metric tons per year. Based on the above analysis, it can be reasonably asserted that these two variants would not result in a significant stationary source GHG impacts.

In summary, GHG impacts under Supplemental Firefighting Water Supply Variants C1 and C2 would be less than significant as described in Section IV.H, Greenhouse Gas Emissions, for the Proposed Project, and would not change the conclusions in that Section.

Biological Resources

Impacts on biological resources would be the same as or similar to those addressed in Section IV.M, Biological Resources, for the Proposed Project, except as discussed here.

Impact BI-9 (Variant C2): Depending on the intake diameter and amount of water suction occurring with Variant C2, there is the potential for significant fish and invertebrate entrainment and/or impingement as well as disturbance to the Islands' intertidal and near subtidal habitat and associated marine biota. (*Less than Significant with Mitigation*)

The extent of impact would depend on final siting and construction design. Mitigation measures discussed in Section IV.M for protecting the intertidal and near subtidal habitats, including sensitive and protected species, would be expected to reduce potential impacts on those habitats from Variants C1 and C2 to less-than-significant levels.

The potential for fish impingement and/or entrainment of important and protected fish and invertebrates such as green sturgeon (*A. medirostris*), salmon species, pacific herring (*Clupea pallasii*), longfin smelt (*Spirinchus thaleichthys*), Dungeness crabs (*Metacarcinus magister*), and shrimp could be significant if the Bay intake pipe is not designed and constructed in a manner that prevents fish impingement.

²² BAAQMD, *Air Quality CEQA Guidelines*, June 2010, pp. 4-5.

Mitigation Measure M-BI-9 (Variant C2): Impingement and/or Entrainment of Protected Fish and Invertebrates

For Variant C2, the Bay water intake pipe for the supplemental fire water supply shall be designed and constructed in a manner that prevents impingement of fish and macroinvertebrates. This could include, but not be limited to installing the intake pipe inside a screened subsea vault large enough to reduce water suction to acceptable levels wherein impingement of marine fauna would not occur. TIDA will submit the final design of the Bay water intake pipe to the National Marine Fisheries; CDFG; California Water Board, San Francisco Region; and BCDC for approval.

Hydrology and Water Quality

Both Variant C1 and Variant C2 would require the installation of additional infrastructure as compared to the Proposed Project, including an additional water storage tank, and additional water mains for Variant C1, and an additional fireboat connection and hydrants, associated piping, and a pump/intake station for Variant C2. These additional construction activities would be managed according to the applicable NPDES General Construction Permit, as described in Section IV.O, Hydrology and Water Quality. Installation of the proposed water tank under Variant C1, and the proposed pump station under Variant C2, would result in the installation of additional impervious surfaces, which would be managed in accordance with the stormwater BMPs discussed in Section IV.O. Therefore, Variants C1 and C2 would result in less-than-significant water quality, stormwater, and erosion/sedimentation impacts, similar to the Proposed Project.

Variant C2 would require the installation of a saltwater intake, pipeline, and fish screen that would not be installed under the Proposed Project. These facilities would result in additional disturbance to the San Francisco Bay floor during construction, including temporary disturbance to bottom sediments and other potential construction-related water quality impacts. However, potential water quality impacts associated with these activities would be minimized via compliance with applicable permits. Permits that would likely be required include a U.S. Army Corps of Engineers permit for construction within a navigable waterway, and review by the Bay Conservation and Development Commission. Both agencies typically impose conditions to mitigate biological resources impacts, including methods to reduce the effects of disturbing bottom sediments on aquatic and benthic life, similar to the NPDES General Construction Permit, and methods to reduce operational impacts on water quality and aquatic organisms. See also Mitigation Measure M-BI-8 (Variant C2), above.

Finally, the three proposed suction hydrants located around the perimeter of Treasure Island under Variant C2 would have impacts similar to those described for the two suction hydrants under the Proposed Project.

Therefore, potential hydrologic resources impacts associated with Variants C1 and C2 would be similar to those of the Proposed Project described in Section IV.O, Hydrology.

Hazards and Hazardous Materials

Hazards impacts under Supplemental Firefighting Water Supply Variants C1 and C2 would be the same as or similar to the environmental impacts addressed in Section IV.P, Hazards and Hazardous Materials, for the Proposed Project, except as described below.

Variants C1 and C2 would include a diesel fuel storage tank for the back-up diesel generator. The diesel fuel storage tank would be similar to the existing diesel fuel storage tanks, which would be moved and continue in use on Treasure Island. Although there would be some additional risk of having additional flammables and/or fuel spills on Treasure Island, diesel fuel storage tanks are built to withstand shocks, including earthquakes, and any increased risk of fire or fuel spill would not be significant. In addition, the diesel storage tank would be an aboveground tank which generally poses less potential risks to the public or environment compared to underground storage tanks. Therefore, hazards impacts associated with the location and operation of above ground diesel storage tanks under Supplemental Firefighting Water Supply Variants C1 and C2 would be less than significant as described in Section IV.P, Hazards and Hazardous Materials, for the Proposed Project, and would not change the conclusions or mitigation proposed there.

Other Topics

Supplemental Firefighting Water Supply Variants C1 and C2 would have impacts similar to the Proposed Projects in the areas of population and housing, archaeological and paleontological resources, historic architectural resources, transportation, wind and shadow, recreation, public services, geology and soils, mineral and energy resources, and agricultural resources and forest land. No new significant impacts would result.

D. WASTEWATER WETLANDS VARIANTS

DESCRIPTION

Two mutually exclusive variants are under consideration for the wastewater treatment facility, each involving the use of wetlands in the wastewater treatment process. Wastewater Wetlands Variant D1 would use constructed wetlands as part of completing tertiary treatment and would not permit public access; Variant D2 would use constructed wetlands for water polishing and could permit public access.

The two variants are being considered because they might further improve water quality. Although the San Francisco Public Utilities Commission (“SFPUC”) has indicated an interest in

further study as to the benefits and feasibility of these variants, implementation of these variants remains uncertain for both technical and financial reasons. The owner and operator of the wastewater treatment facility, SFPUC, would make the determination as to whether either variant would be implemented after preparing a cost-benefit analysis. For Variant D1, the variant would add to capital costs, as well increase operational costs through additional pumping and maintenance of the system, which may or may not be offset by the operational and financial benefits offered by the variant. Under Variant D2, the costs of constructing and maintaining the system may or may not be warranted for the water quality benefits gained by polishing of effluent which has already been fully treated to discharge compliance standards. The SFPUC has not finalized its operational and financial analysis nor has it committed to providing the funds necessary to construct either of these wetlands. Nevertheless, because SFPUC is considering the adoption of either one of these variants, they are each further analyzed below.

Wastewater Wetlands Variant D1 would use constructed wetlands for tertiary treatment of the portion of the secondary-treated effluent from the treatment plant to be recycled; this would occur prior to the microfiltration step, reducing the need for reverse osmosis for the recycled water. The constructed wetlands would include both open water areas and emergent plants, with the water depth varying from 1.5 to 4 feet. Public access to the constructed wetlands in Wastewater Wetlands Variant D1 would be restricted. Bulrushes and native wetland plant species would be used in the shallower wetlands areas. As with the stormwater wetlands in the Proposed Project, mosquito control measures would be used, such as mosquitofish, varied water levels, and vegetation maintenance to reduce mosquito habitat. The wetlands in this Wastewater Wetlands Variant D1 would be constructed on about 5 acres of land adjacent to the proposed wastewater treatment facility site in the northeast corner of Treasure Island.

- Wastewater Wetlands Variant D2 would use wetlands to polish the majority of the treated wastewater effluent to be discharged through the outfall, after microfiltration and disinfection. In this process, recycled water would not pass through the wetlands; about 0.42 mgd would be diverted from the treatment plant and further treated, to the extent necessary, with reverse osmosis for use in landscape irrigation and appropriate plumbing fixtures in commercial and residential buildings. Wastewater Wetlands Variant D2 would receive the remainder of the disinfected effluent from the treatment plant (about 0.9 mgd). It would be smaller than Variant D1. Variant D2 would be constructed on about 2 to 4 acres of land and would be suitable to serve as wildlife habitat. Public access to the constructed wetlands in Wastewater Wetlands Variant D2 would not be restricted because the water in it would be disinfected.

IMPACT EVALUATION

Land Use

Land use impacts under Wastewater Wetlands Variants D1 and D2 would be the same as or similar to the environmental impacts addressed in Section IV.A, Land Use and Land Use Planning, for the Proposed Project, except as described here.

Wastewater Wetlands Variant D1 would occupy about 5 acres for the wetland, and Variant D2 would occupy about 2 to 4 acres. The wastewater wetlands would be located in the proposed open space areas adjacent to the wastewater treatment plant. Overall, although the open space would not be available for the same types of recreational activities, the land use would not be substantially different from that included in the Proposed Project. No new significant impacts on land use would result from implementation of either of these variants. Therefore, land use impacts under Wastewater Wetlands Variants D1 and D2 would be less than significant as described in Section IV.A, Land Use and Land Use Planning, for the Proposed Project, and would not change the analysis or conclusions presented there.

Aesthetics

Aesthetics impacts under Wastewater Wetlands Variants D1 and D2 would be the same as or similar to the environmental impacts addressed in Section IV.B, Aesthetics, for the Proposed Project, except as described here.

Viewed from mainland locations, the impact on scenic vistas and visual quality of these variants would be substantially the same as that described for the Proposed Project. Viewed from island locations, the visual character of the wetlands under these variants would be similar to that of the Proposed Project. As with the Proposed Project these variants would be required to conform to the design guidelines for the Wastewater Treatment Plant in Section T5.9 of the proposed draft *Design for Development*. Conformity with approved design guidelines in the draft *Design for Development* would ensure that these variants would not cause a significant adverse impact on the visual quality of Treasure Island. Therefore, aesthetics impacts under Wastewater Wetlands Variants D1 and D2 would be similar to those described in Section IV.B, Aesthetics, for the Proposed Project, and would not change the analysis or conclusions of that section.

Recreation

Recreation impacts under Wastewater Wetlands Variants D1 and D2 would be the same as or similar to the environmental impacts addressed in Section IV.J, Recreation, for the Proposed Project, except as described here.

Under Wastewater Wetlands Variant D1, public access to the approximately 5 acre wetland would be restricted. As explained in Section IV.J., Recreation, under Impact RE-2, p. IV.J.18, the Proposed Project would improve access to recreational facilities and would provide approximately 300 acres of recreational and open space. The Proposed Project would exceed by a factor of two the existing open space and recreation areas to be displaced (or modified). Under Wastewater Wetlands Variant D1 about 5 acres of the planned 300 acres of open space would be removed from public accessibility. Nevertheless, there would still be far more acreage added than existing open space displaced, and the wetlands would remain visual open space. Therefore, there would be no significant recreational impacts under Variant D1.

Wastewater Wetlands Variant D2 would allow public access to the wetland. There would be opportunities to view the wetland and the wildlife using the wetland. Variant D2 would not have a significant impact on recreation.

Therefore, recreation impacts under Wastewater Wetlands Variants D1 and D2 would be similar to those described in Section IV.J, Recreation, for the Proposed Project, and would not change the analysis or conclusions of that section.

Biological Resources

Biological Resources impacts under Wastewater Wetlands Variants D1 and D2 would be the same as or similar to the environmental impacts addressed in Section IV.M, Biological Resources, for the Proposed Project, except as described here.

Marine: As discussed in Section IV.M, any discharge from the wetlands to the Bay, regardless of the quality and/or physical condition of the source water, would be covered by an NPDES permit issued by the Regional Water Quality Control Board (RWQCB) and would be required to comply with the Basin Plan for San Francisco Bay. Through compliance with the NPDES permit and the Basin Plan potential impacts associated with methyl mercury generation would be less than significant. As such, the potential for impacts to marine habitat and associated biota from either Variant is expected to remain the same, as discussed for the Proposed Project, and would be less than significant.

Terrestrial Wildlife: In Section IV.M, the stormwater wetlands were considered a benefit to wildlife and no impact was identified. Wastewater wetlands are somewhat more complex. Generally, as demonstrated by 17 wetland treatment system case studies located in 10 states, the USEPA concluded that these systems can provide valuable wetland habitat for waterfowl and other wildlife.²³ On the other hand, wetlands receiving wastewater may also be prone to the

²³ U.S. Environmental Protection Agency. 1993. Constructed Wetlands for Wastewater Treatment and Wildlife Habitat Management. EPA832-R-93-005. September. <http://www.epa.gov/wetlands/pdf/Introduction.pdf>.

bioaccumulation of potentially harmful anthropogenic substances. Waterfowl can be affected by the presence of heavy metals, for example, in plants and invertebrates consumed. Wastewater Wetland Variant D1 would use constructed wetlands for tertiary treatment of the portion of the secondary-treated effluent from the treatment plant, whereas D2 would use wetlands to “polish” already treated water. Therefore, the potential for adverse impacts is greater under D1. However, secondary-treated water in variant D1 is of higher quality than the proposed stormwater, and determining the significance of those impacts would be speculative, especially given the highly mobile nature of birds using a wetland, their exposure to harmful substances at other sites, varying time on the wetland, and different rate and “uptake” of these substances by different plants and in different seasons.

Hydrology and Water Quality

Hydrology and water quality impacts under Wastewater Wetlands Variants D1 and D2 would be the same as or similar to the environmental impacts addressed in Section IV.O, Hydrology and Water Quality, for the Proposed Project, except as described here.

The Wastewater Wetlands Variants would involve the installation of wetlands for treatment of wastewater on Treasure Island. The wetlands would be constructed/engineered and would be in a location that is separate from any natural waterways. They would be protected from overflow during storm events. For Variant D1, where the wetlands would support treatment of recycled wastewater, the effluent from the wetlands would eventually be piped back into the Proposed Project’s recycled water system. This recycled water would be required to meet the same Federal, State, and local standards for recycled water quality as compared to the Proposed Project. Therefore, no water quality degradation would occur.

Under Variant D2, the wetland areas would be used to support wastewater treatment, prior to discharge of the treated wastewater into San Francisco Bay using the wastewater treatment plant discharge facilities. The proposed wetlands would support the wastewater treatment process. Effluent quality of the wastewater treatment plant discharge into the Bay would be required to meet applicable Waste Discharge Requirements under the plant’s NPDES permit. The Waste Discharge Requirements would not be altered as a result of installation of the proposed wetlands. Therefore, the proposed wetlands would not result in reduced water quality, as compared to the Proposed Project.

Therefore, hydrology and water quality impacts under Wastewater Wetlands Variants D1 and D2 would be similar to those described in Section IV.O, Hydrology and Water Quality, for the Proposed Project, and would not change the analysis or conclusions presented there.

Hazards and Hazardous Materials

Hazards impacts under Wastewater Wetlands Variants D1 and D2 would be the same as or similar to the environmental impacts addressed in Section IV.P, Hazards and Hazardous Materials, for the Proposed Project, except as described below.

The construction of wetlands would require grading activities and excavation of existing surface soils. Depending on the location of the Wetland Variants, hazardous materials or wastes could be encountered in subsurface soils or groundwater. Similar to the potential impacts discussed for the stormwater wetland as well as any other grading activities for the proposed development, the potential impacts would be mitigated to a less-than-significant level through implementation of a Soil and Groundwater Management Plan, which provides detailed protocols and handling procedures for any suspect materials. Therefore, although there would be an increase in subsurface materials disturbed, and as a result an increased potential for encountering potentially hazardous materials, the mitigation measures for the other construction activities would continue to be effective for the Wetland Variants.

Therefore, hazards impacts under Wastewater Wetlands Variants D1 and D2 would be similar to those described in Section IV.P, Hazards and Hazardous Materials, for the Proposed Project, and would not change the analysis and conclusions or mitigation measures identified there.

Other Topics

Wastewater Wetlands Variants D1 and D2 would not result in any new impacts in the areas of population and housing, archaeological and paleontological resources, historic architectural resources, transportation, noise, air quality, greenhouse gases, wind and shadow, utilities and service systems, public services, geology and soils, mineral and energy resources, or agricultural resources and forest land compared to those identified for the Proposed Project.

E. AUTOMATED WASTE COLLECTION SYSTEM VARIANT

DESCRIPTION

An automated, mechanical system to collect solid waste from new buildings (“Automated Waste Collection System”) on Treasure Island is under consideration by the project sponsors. This system would be constructed as part of the subsurface infrastructure on Treasure Island and buildings would connect to this system as they were built. The system would terminate in a central waste handling facility, likely to be located in the vicinity of the new Police/Fire station or the Urban Agricultural Park on the edge of the Island Center on Treasure Island, where the solid waste would be loaded into trucks and hauled to a processing facility on the mainland after materials that could be composted on Treasure Island were separated. This automated solid waste collection facility is not proposed to be extended to Yerba Buena Island because building density

would be too low for efficiency. Solid waste collection on Yerba Buena Island would be handled as in the Proposed Project, using standard trash collection trucks that would circulate to pick up trash separated by residents and businesses into recyclables, compostables, and trash. Waste materials would be sent off-site, except for that portion of the material that could be composted on Treasure Island.

The Automated Waste Collection System is being considered because it has the potential to operate more efficiently and would reduce the number of trash collection truck trips and the associated noise. However, the technology is relatively new, and its implementation would require a large investment by the third-party waste management system operator. The Automated Waste Collection System is not part of the Proposed Project and there is no identified funding source. Therefore its implementation remains uncertain.

The automated system on Treasure Island would be designed to accept recyclables, compostables, and trash at separate loading stations in buildings and in public areas, replacing interior and outdoor trash receptacles. In buildings served by common areas, expected to be all buildings over about four stories on Treasure Island, centrally located trash chutes would be provided for each waste stream. For townhomes and other lower-density residential buildings without common areas, loading stations would be placed at locations convenient to groups of residential units. Material would be temporarily stored at the bases of the chutes in higher density buildings and inside the loading stations in the lower density areas.

On a regularly scheduled basis, the different types of stored material would be automatically removed using transport pipes with air stream up to 60 mph directing the waste to the central collection point. Each type of material would be collected and compacted at the central collection station before being hauled to an off-site processing facility. A portion of the compostables collected at the facility would be directed to the Treasure Island composting facility.

The central collection facility would be about 15,000 to 20,000 sq. ft. and no more than 35 feet tall. It could be located within a parking garage or below a parking deck, or in another location that meets the overall development objectives. It would house the suction equipment fans and air compressors, air scrubbers, waste separators, compactors, and containers for temporary storage. Full containers would be collected at a staging facility and loaded on to two to four trucks daily for off-haul. Wet scrubbers would be designed and operated to remove airborne particulates.

IMPACT EVALUATION

Land Use

Land use impacts under the Automated Waste Collection System Variant would be the same as or similar to the environmental impacts addressed in Section IV.A, Land Use and Land Use Planning, for the Proposed Project, except as described here.

The central collection facility would be about 15,000 to 20,000 sq. ft. in size and could be located within a parking garage or below a parking deck or in another location that is consistent with the overall development objectives. The facility would likely be located in the highly concentrated, mixed use, Island Center District, as shown in Figures IV.A2 and IV.A.3 in Section IV.A, Land Use and Land Use Planning. As an infrastructure use in the highly concentrated, mixed use, Island Center District, the central collection facility would likely be sited near a parking garage and/or commercial or institutional uses. It would not be substantially different from other infrastructure building and related uses. As with any proposed new building on Treasure Island under the Proposed Project, this variant would be required to conform to the design guidelines for new construction on Treasure Island included in the draft *Design for Development*. The central collection facility would conform to the design guidelines related to industrial and infrastructure buildings and would also be subject to setbacks and screening. Therefore, similar to above-grade parking garages, the central collection facility would be designed to be compatible with the character of the adjacent land uses. This variant would not result in new significant land use impacts, as with the Proposed Project.

In summary, land use impacts under the Automated Waste Collection System Variant would be less than significant as described in Section IV.A, Land Use and Land Use Planning, for the Proposed Project, and would not change the analysis or conclusions presented there.

Aesthetics

Aesthetics impacts under the Automated Waste Collection System Variant would be the same as or similar to the environmental impacts addressed in Section IV.B, Aesthetics, for the Proposed Project, except as described here.

The central collection facility would be about 15,000 to 20,000 sq. ft. and no more than 35 feet tall. It could be located within a parking garage or below a parking deck, or in another location that is consistent with the overall development objectives. It would be located in the Island Center District of Treasure Island, and would not be visible from off-island locations. Other parts of the Automated Waste Collection System would be underground, except for small trash chutes in neighborhood collection areas. Therefore, implementation of the Automated Waste Collection System would not have significant aesthetic impacts. As with any proposed new building on Treasure Island under the Proposed Project, this variant would be required to conform to the design guidelines for new construction on Treasure Island included in the draft *Design for Development*. Conformity with approved design guidelines in the draft *Design for Development* related to industrial and infrastructure buildings and setbacks and screening would ensure that this variant would not cause a significant adverse impact on the visual quality of Treasure Island.

In summary, aesthetics impacts under the Automated Waste Collection System Variant would be similar to those described in Section IV.B, Aesthetics, for the Proposed Project, and would not change the analysis or conclusions of that section.

Transportation

Transportation impacts under the Automated Waste Collection System Variant would be the same as or similar to the environmental impacts addressed in Section IV.E, Transportation, for the Proposed Project, except as described here.

This variant would reduce the number of truck trips between Treasure Island and the transfer station and recycling facilities in San Francisco, and also internal route truck trips within Treasure Island for trash and recycling pickup. The amount of reduction would be small in relation to the overall numbers of vehicle trips generated by the Proposed Project. Therefore, this variant would have transportation impacts similar to those of the Proposed Project, with somewhat fewer truck trips, and would not change the conclusions or mitigation measures identified in Section IV.E, Transportation.

Noise

Noise impacts under the Automated Waste Collection System Variant would be the same as or similar to the environmental impacts addressed in Section IV.F, Noise, for the Proposed Project, except as described here.

Construction of the Automated Waste Collection System facilities would have similar types of construction-related noise impacts and mitigation measures as discussed for the Proposed Project in Section IV.F, Noise. No new significant construction noise impacts would result from implementing this variant, and no new mitigation measures would be required.

The central collection facility's equipment would generate mechanical noise. At maximum operating speeds, the fans could typically produce between 100 and 125 dB depending on octave range (measured 10 ft from unit).²⁴ The project sponsors would require that the operator of the collection facility reduce fan noise by acoustical treatments on walls and ceilings, and silencers and other methods on the exhaust pipe, to reduce noise levels to 85 dB or less.²⁵

The central collection facility would be in an enclosed building. In addition to the project sponsors' noise reduction methods, noise shielding would be installed as necessary to comply with the San Francisco Noise Ordinance. Shielding and enclosing this facility would be sufficient to ensure compliance with the Noise Ordinance. Therefore, there would be no new significant noise impacts on surrounding land uses.

²⁴ Galovich memo, 9/14/2009, p. 7.

²⁵ *Ibid.*

There would be noise from waste hauling truck trips in and out of the facility, but less overall truck noise due to slightly fewer overall trips around Treasure Island, and slightly fewer truck trips to and from Treasure Island. Therefore, the variant would not result in a change in transportation-generated noise impacts.

In summary, noise impacts under the Automated Waste Collection System Variant would be similar to those described in Section IV.F, Noise, for the Proposed Project, and would not change the analysis, conclusions or mitigation measures identified there.

Air Quality

Air quality impacts under the Automated Waste Collection System Variant would be the same as or similar to the environmental impacts addressed in Section IV.G, Air Quality, for the Proposed Project, except as described here.

Construction of the Automated Waste Collection System facilities would have air quality construction impacts similar to those of the Proposed Project, and the same mitigation measure, M-AQ-1, would apply.

During operation, there would be fewer overall truck trips compared to the Proposed Project, resulting in slightly decreased air emissions. The reduction would not be sufficient to reduce any significant impacts identified for the Proposed Project to less-than-significant levels.

At the central collection facility, wet scrubbers would be designed and operated to remove airborne particulates. Particulate emissions from the facility would be less than significant.

Any solid waste collection system has the potential for odors from organic decomposition and other odorous waste. However, under this variant, the collection system pipes would be under negative pressure (i.e., vacuum towards the central collection facility), including frequent “flushes” with jets of air. Organic material in the system would not be expected to linger long enough to produce objectionable odors, and no significant impact would result.

At the central collection facility, each of the three waste streams (recyclables, compostables, and trash) waste would enter its designated cyclone waste separator and fall into a feed hopper and then a compactor.²⁶ The material would then be pushed (and compacted) into 40 cubic yard containers. Full containers would be disconnected from the compactor and moved to a staging location. An empty container would be moved into place and connected to the compactor. The containers would be moved using an automated rail-based or other automated positioning system. The staged (full) containers would be stored for loading onto trucks. The process described

²⁶ The process description in this paragraph is based on Galovich memo, 9/14/2009, pp. 4-5.

above generally would keep the material under sealed conditions, reducing the potential for odors in the vicinity of the central facility.

According to a manufacturer, this type of system has been installed at many locations around the world; these locations do not have odor problems.²⁷ Given the engineering characteristics of the system, odor problems, if any, would be limited to the environs immediately surrounding the central collection facility. Because the containers receiving the waste would be sealed and driven off-site, odor is not expected to be a significant impact.

In summary, air quality impacts under the Automated Waste Collection System Variant would be similar to those described in Section IV.G, Air Quality, for the Proposed Project, and would not change the analysis and conclusions, or the mitigation measures identified there.

Hydrology and Water Quality

Construction-related impacts on hydrology and water quality of installing the Automated Waste Collection System would be the same as those described for the Proposed Project in Section IV.O, Hydrology and Water Quality. Mitigation Measure M-HY-1, p. IV.O.35, identified as reducing the potential for hazardous materials in groundwater to cause water quality impacts during construction, would be applicable to this variant, and would reduce construction impacts to less-than-significant levels, as with the Proposed Project.

The wet scrubber's water would be recycled within the scrubber until it would need to be replaced. The effluent would be filtered and then discharged to the sanitary sewer.²⁸ This system would not have a significant impact on water quality. The less-than-significant impacts of the proposed wastewater collection and treatment system discussed in Section IV.O, Hydrology and Water Quality, would not change with implementation of this variant.

Hazards and Hazardous Materials

Hazards impacts under the Automated Waste Collection System Variant would be the same as or similar to the environmental impacts addressed in Section IV.P, Hazards and Hazardous Materials, for the Proposed Project, except as described here.

Construction impacts of installing the Automated Waste Collection System's subsurface facilities would be the same as those described in Section IV.P, Hazards and Hazardous Materials for the Proposed Project. Implementation of Mitigation Measure M-HZ-1, to prepare and implement a Soil and Groundwater Management Plan, on p. IV.P.41, would reduce construction-related impacts to less-than-significant levels.

²⁷ Turnstone Consulting, personal communication with Transvac personnel, Jan. 7, 2010.

²⁸ Galovich memo, 9/14/2009, p. 7.

Groundwater on Treasure Island has been found to contain hazardous chemicals in some locations, as discussed in Section IV.P. Although much groundwater contamination is expected to be removed during the Navy's cleanup programs, as discussed in the Background and Setting in Section IV.P, Hazards and Hazardous Materials, some could remain in the groundwater. Depending on what the subsurface piping is composed of, it is possible that small amounts of contaminated groundwater could infiltrate the pipes of the proposed Collection System. If the pipes were constructed of impervious materials, substantial amounts of infiltration would not be expected to occur.

The Proposed Project would include a household hazardous waste collection program. Businesses and government agencies would have to comply with various hazardous waste laws and regulations prohibiting putting hazardous wastes into the solid waste stream. Despite these efforts to keep hazardous materials and wastes out of the Automated Waste Collection System, a de minimus amount may be inadvertently placed in the collection system. As explained in Section IV.P, Hazards and Hazardous Materials, Impact HZ-4, pp. IV.P.44 – IV.P.45, with adherence to the regulatory environment surrounding the use, storage and disposal of typical office and household hazardous materials and wastes, the potential impact would be less than significant. The central collection system variant would not change the analysis or conclusions regarding this impact.

In summary, hazards impacts under the Automated Waste Collection System Variant would be similar to those described in Section IV.P, Hazards and Hazardous Materials, for the Proposed Project, and would not change the analysis and conclusions or mitigation measures identified there.

Mineral and Energy Resources

Mineral and energy resources impacts under the Automated Waste Collection System Variant would be the same as or similar to the environmental impacts addressed in Section IV.Q, Mineral and Energy Resources, for the Proposed Project, except as described here.

Suction equipment fans and air compressors, air scrubbers, waste separators, and compactors, would all use electricity. The project sponsors estimate total system energy consumption would be on average approximately 2 - 4 kWh per month per permanent resident, depending on the ultimate design of the system.²⁹ Electricity consumption would be higher than the Proposed Project; however, haul truck diesel-fuel use would be lower. Given the energy efficiency and sustainable aspects included, this variant would not have a significant impact on energy resources. Therefore, mineral and energy resources impacts under the Automated Waste Collection System Variant would be similar to those described in Section IV.Q, Mineral and

²⁹ Galovich memo, 9/14/2009, pp. 7-8.

Energy Resources, for the Proposed Project, and would not change the analysis or conclusions in this section.

Other Topics

The Automated Waste Collection System Variant would have impacts the same as those identified for the Proposed Project in the areas of population and housing, archaeological and paleontological resources, historic architectural resources, wind and shadow, recreation, utilities and service systems, public services, biological resources, geology and soils, and agricultural resources and forest land. No new significant impacts would result in these areas.

F. OFF-SITE ELECTRICAL TRANSMISSION FACILITY IMPROVEMENTS VARIANT

DESCRIPTION

As described in Section IV.K, Utilities and Services Systems, on p. IV.K.69, transmission of electricity from the PG&E grid to the Islands starts at PG&E's "Station C" at Grove Street and Second Street in Oakland. A 115 kV overhead transmission line carries power about 2.1 miles to the Davis Substation at Seventh Street and Maritime Street on Port of Oakland property. An overhead line carries the power to the shoreline near the eastern end of the Bay Bridge, connecting to the submarine cable that connects to Treasure Island.

Although the capacity of these off-site electrical transmission facilities is sufficient, a number of upgrades to the off-site electrical system could be made to improve capacity and reliability.

These upgrades could be a combination of one or more of the following activities:

- Add fans at the Davis Street Substation to cool equipment, thereby improving capacity and reliability.
- Add switchgear at the Davis Street Substation and add 12 kV connections (bus ties) at the adjacent Cuthbertson Substation, to provide reliability and redundancy. (New concrete pads, trenching, and conduit/cable would be needed.)
- Re-conductor the existing overhead distribution line between the Davis Street Substation and the submarine cable, using the existing poles and pole framing, to provide increased capacity.
- Rebuild the existing overhead distribution line at the same or greater capacity, with new poles, between the Davis Street Substation and the submarine cable, to provide additional capacity and reliability.
- Add one or two new underground lines between the Davis Street Substation and the submarine cable, to either expand (one underground line plus existing overhead line) or replace and expand (two underground lines with no overhead line) capacity, reliability and redundancy.

- Connect the existing submarine cable to the existing PG&E distribution system via a short overhead wire, to provide reliability and redundancy if capacity is available in that part of the distribution system.

The opportunities to combine one or more of these upgrades include the following: 1) making the improvements at the Davis Street Substation, to add fans and to tie the substation to the adjacent Cuthbertson Substation; 2) adding fans at the Davis Street Substation and undergrounding existing overhead lines; or 3) tying the Davis and Cuthbertson Substations, re-conductoring the existing overhead lines, and connecting the submarine cable to the existing PG&E distribution system. It is less likely that both undergrounding the overhead lines would be combined with retaining or improving the overhead lines.³⁰

The decision to implement any of these upgrades would be made by the power provider, and would be contingent on identifying funds to pay for such upgrades.

This variant would be constructed on Port of Oakland and City of Oakland property in an industrial area occupied by trucking transport facilities, parking lots, backlands for storing shipping containers, and other support services for the ocean shipping activity that occurs at this Port. The location is shown on Figure IV.K.7, p. IV.K.76, in Section IV.K, Utilities and Service Systems.

IMPACT EVALUATION

Archaeological and Paleontological Resources

Impacts to archaeological and paleontological resources under the Off-Site Electrical Transmission Facility Improvements Variant would be the same as or similar to the environmental impacts addressed in Section IV.D.1, Archaeological and Paleontological Resources, for the Proposed Project, except as described here.

Construction of some of the off-site electrical facilities would involve small amounts of excavation to install subsurface wiring or other facilities. There would be a limited likelihood of encountering subsurface archaeological deposits, because the area is already fully developed with roads and buildings and because the excavation would be relatively shallow. Therefore, archaeological and paleontological resources impacts under the Off-Site Electrical Transmission Facility Improvements Variant would be similar to those described in Section IV.D.1, Archaeological and Paleontological Resources, for the Proposed Project, and would not change the analysis and conclusions presented there. Mitigation measures identified in Section IV.D.1 would reduce any potential significant impacts to less-than-significant levels.

³⁰ *Infrastructure Update*, Chapter 11, Addendum, Section 11.2.2, Table 11.2, August 18, 2009.

Transportation

Transportation impacts under the Off-Site Electrical Transmission Facility Improvements Variant would be the same as or similar to the environmental impacts addressed in Section IV.E, Transportation, for construction of the Proposed Project, except as described here.

Construction of these facilities would occur in an industrial area dominated by shipping and transportation activities and could result in short-term temporary impacts on traffic and emergency vehicle access. These impacts would be typical of infrastructure construction and repair that occurs throughout urban areas. Similar to the Proposed Project, which includes a construction traffic management program as mitigation for the traffic effects of construction activities, this variant would also be expected to include a construction traffic management program, coordinated with the Port of Oakland. However, unlike the Proposed Project, the construction-related traffic impacts would be less than significant because of the short-term, temporary nature of this work. Project-related transportation impacts under the Off-Site Electrical Transmission Facility Improvements Variant would be similar to those described in Section IV.E, Transportation; addition of the Off-Site Electrical Transmission Facility Improvements to the Proposed Project would not change the analysis and conclusions or mitigation measures identified for the Proposed Project.

Noise

Construction of these facilities would occur in an industrial area dominated by shipping and transportation activities, with no sensitive receptors located nearby. Therefore, temporary construction noise impacts would not be significant. Some of the mechanical equipment, such as fans, may emit noise, including the hum of switch-station equipment, during operation. In this industrial area, the added operational noise would not be significant.

Air Quality

Construction of these off-site electrical facilities would have types of construction-related emissions similar to those identified for the Proposed Project, i.e., dust, equipment emissions, and truck emissions; however, they would be short term and temporary, and would not be significant. Appropriate features from Mitigation Measure M-AQ-1 would typically be required by the Port of Oakland during construction, although they would not be necessary to reduce significant air quality impacts to less-than-significant levels. This variant would not contribute substantially to the Proposed Project's significant construction-related air quality impacts because the activity would be located on the mainland, several miles from the Islands, and because of the short duration of construction activities.

Hazards and Hazardous Materials

Hazards impacts under the Off-Site Electrical Transmission Facility Improvements Variant would be the same as or similar to the environmental impacts addressed in Section IV.P, Hazards and Hazardous Materials, for the Proposed Project, albeit in a different location.

The off-site electrical transmission facility would be located on lands in the vicinity of the Port of Oakland, the Oakland Army Base, and the Oakland touchdown of the Bay Bridge, including portions of the Gateway Redevelopment Site. There have been numerous hazardous materials subsurface investigations and remedial activities carried out at the former base. Potential contaminants of concern in the groundwater include petroleum hydrocarbons, poly-aluminum chloride, volatile organic compounds, arsenic, manganese, benzene, toluene, ethyl benzene, xylene, methyl tertiary-butyl ether, and tetrachloroethylene.³¹ Potential contaminants of concern in the soil would include the same chemicals as those listed for groundwater in addition to acetone, lead, pesticides, cis-1,2-Dichloroethene, dichloromethane, vinyl acetate, and methylene chloride. While some of these contaminants are not present at Treasure Island or Yerba Buena Island, the same protocols as those called for in the Soil and Groundwater Management Plan for the Proposed Project (described in Section IV.P, Hazards and Hazardous Materials, in Mitigation Measure M-HZ-1 on pp. IV.P.41 – IV.P.42) would also be effective in reducing the potential significant effects of this variant.

In summary, hazards impacts under the Off-Site Electrical Transmission Facility Improvements Variant would be similar to those described in Section IV.P, Hazards and Hazardous Materials, for the Proposed Project, and would not change the analysis and conclusions or mitigation measures identified there.

Other Topics

Construction and operation of the off-site electrical improvements in this variant would not result in any changes in land use. If some existing overhead wires were undergrounded, visual conditions would improve; however, as the location is on and adjacent to working Port property, and therefore industrial in nature, overhead wires do not substantially impair the visual conditions in the area. The area where the substation, power lines, and cable connection are located is fully developed and industrial in nature. Therefore there are no special status species, and no significant biological impacts would occur during or following construction. This variant would not result in changes in population and housing, historic architectural resources, wind and

³¹ Stephanie Pavela and James Richie, LFR/Arcadis, Memorandum to Alex Galovich, TICD, "Preliminary Discussion of Environmental Considerations for the Utility and Infrastructure Easement Prior to Undergrounding, Eastern Approach to Treasure Island," October 21, 2009. A copy of this document is available for public review at the San Francisco Planning Department, 1650 Mission Street, Suite 400, in Case File No. 2007.0903E.

shadow, recreation, public services, geology and soils, mineral and energy resources, or agricultural resources and forest land.

VII. ALTERNATIVES

This chapter identifies alternatives to the Proposed Project and discusses the environmental effects associated with them. *CEQA Guidelines* Section 15126.6 requires that an EIR describe a reasonable range of feasible alternatives to a proposed project that could attain most of the basic project objectives. The alternatives considered should focus on elimination or reduction of significant adverse impacts caused by a proposed project.

An EIR need not consider every conceivable alternative to a proposed project. Rather, it must consider a reasonable range of potentially feasible alternatives that will foster informed decision-making and public participation. An EIR is not required to consider alternatives that are infeasible. *CEQA Guidelines* Section 15126.6(f)(1) states that “among the factors that may be taken into account when addressing the feasibility of alternatives are site suitability, economic viability, availability of infrastructure, general plan consistency, other plans or regulatory limitations, jurisdictional boundaries (projects with a regionally significant impact should consider the regional context), and whether the proponent can reasonably acquire, control or otherwise have access to the alternative site (or the site is already owned by the proponent).” The final determination of feasibility will be made by project decision-makers based on substantial evidence in the record, which includes, but is not limited to, information presented in the EIR, comments received on the Draft EIR, and responses to those comments.

The analysis of alternatives is of benefit to decision-makers because it provides more complete information about the potential impacts of land use decisions, and consequently a better understanding of the inter-relationships among all of the environmental topics under evaluation. The City must consider approval of an alternative if that alternative would substantially lessen or avoid significant environmental impacts identified for a proposed project and that alternative is determined to be feasible.

The land uses, transportation program, sustainability goals, and other elements of the Proposed Project were established through a multi-year planning and environmental review process that began in 1997. The 2006 Term Sheet and its accompanying *Transportation Plan*, *Land Plan*, *Sustainability Plan*, and *Infrastructure Plan*, among other exhibits, were developed based on numerous public meetings and with considerable public input and, as amended in 2010,¹ forms the basis for the Proposed Project analyzed in this EIR. After reviewing potential significant impacts of the Proposed Project, a range of alternatives was identified, based on prior development proposals, comments received during the Notice of Preparation (“NOP”) and public

¹ The Update to the *Development Plan and Term Sheet for the Redevelopment of Naval Station Island Treasure Island* was endorsed by the TIDA Board in April 2010 and by the Board of Supervisors in May 2010.

scoping process for this EIR, and consideration of approaches that could avoid or reduce identified impacts. An analysis of these alternatives was conducted to determine which would be feasible, meet most of the project sponsors' objectives, and reduce or avoid some or all significant impacts.

The following alternatives to the Proposed Project that met these criteria are discussed and evaluated in this chapter:

- A. No Project Alternative;
- B. Reduced Development Alternative;
- C. No Ferry Service Alternative; and
- D. Reduced Parking Alternative.

- The differences between the Proposed Project and the development programs for Alternative B, Reduced Development Alternative, Alternative C, No Ferry Service Alternative, and Alternative D, Reduced Parking Alternative, are shown in Table VII.1.

The alternatives analyzed in this EIR have been developed to focus on those that are capable of avoiding or substantially lessening one or more of the significant impacts identified for the Proposed Project pursuant to *CEQA Guidelines* Section 15126.6(b). Significant impacts of the Proposed Project are described in Chapter IV, Environmental Setting and Impacts, and have been identified for the following topics: aesthetics; historic resources; transportation; noise; air quality; wind; biological resources; geology and soils; hydrology and water quality; and hazards. Many of these impacts can be reduced to less than significant with mitigation; however, as discussed in Chapter V, Section B, Significant Unavoidable Impacts, p. V.3, some of the impacts pertaining to aesthetics, historic resources, transportation, noise, air quality, wind, and biological resources would be significant and unavoidable, even with implementation of mitigation measures identified in this EIR.

The alternatives discussed below would avoid or lessen one or more of the significant unavoidable environmental impacts of the Proposed Project, and/or would reduce or eliminate one or more significant environmental effects that could be mitigated, avoiding the need for mitigation.

Among the alternatives analyzed, this chapter identifies an environmentally superior alternative that would result in the least adverse effects on the environment.

● **Table VII.1: Comparison of Alternatives to the Proposed Project**

Topic	Proposed Project	Alternatives Considered			
		No Project Alternative	Reduced Development Alternative	No Ferry Service Alternative	Reduced Parking Alternative
Land Uses					
Residential	8,000 units	No change from existing 1,005 units	6,000 units	5,100 units	8,000 units
Retail	207,000 sq. ft.	No change from existing conditions	207,000 ¹ sq. ft.	207,000 sq. ft.	207,000 sq. ft.
Commercial office	100,000 sq. ft.	No change from existing conditions	No office space	100,000 sq. ft.	100,000 sq. ft.
Hotel	500 hotel rooms	No hotel rooms	500 hotel rooms	500 hotel rooms	500 hotel rooms
Parking	10,675 spaces	No change from existing conditions	8,955 ² spaces	8,255 ³ spaces	6,651 ⁶ spaces
Parks and public open space	300 acres	No change from existing 170 acres	300 acres	306 ⁴ acres	300 acres
New/Upgraded public services, infrastructure and utilities	Yes	No	Yes	Yes	Yes
Historic Resources					
Rehabilitation and adaptive reuse of historic structures ⁵	Yes	No	Yes	Yes	Yes
Preservation of Historic Resource (<i>U.S.S. Buttercup</i>)	No	Yes	No	Yes	No
Transportation					
New ferry service	Yes	No	Yes	No	Yes
Improved bus transit service	Yes	No	Yes	Yes	Yes
New bicycle and pedestrian facilities	Yes	No	Yes	Yes	Yes
Subject to Tidelands Trust Exchange Agreement	Yes	No	Yes	Yes	Yes
Geotechnical Stabilization of TI and YBI causeway	Yes	No	Yes	Yes	Yes
Development of Non-Renewable Resources Infrastructure	Yes	No	Yes	Yes	Yes
Implementation of Sustainability Plan	Yes	No	Yes	Yes	Yes
Implementation of Habitat Management Plan for YBI	Yes	No	Yes	Yes	Yes

Notes:

¹ Compared to the Proposed Project, the Reduced Development Alternative would likely include less neighborhood-serving retail uses (25 percent less) and more regional-serving retail uses.

² This total is based on a reduced number of residential units, no new commercial office space, and a smaller proportion of neighborhood-serving retail uses.

³ This total is based on a reduced number of residential units.

⁴ This total includes the 6 acres on Blocks E5 and E7, the site of the Damage Control Trainer (*U.S.S. Buttercup*), which would be retained in the No Ferry Service Alternative.

⁵ Historic rehabilitation and adaptive reuse of Buildings 1, 2, and 3 on Treasure Island; and the Nimitz House, Senior Officers' Quarters Historic District, Quarters 10, Building 267, and Torpedo Assembly Building on Yerba Buena Island.

⁶ This total is based on providing 0.5 space for each residential unit and reduced parking ratios for the hotel, office, and adaptively reused space in historic buildings.

Source: Turnstone Consulting, June 2010

This chapter also discusses alternatives to the Proposed Project that were considered but not analyzed further because they were rejected as infeasible or failed to meet most of the project sponsors' basic objectives. These include a No Tidelands Trust Exchange Alternative; a 2,800 Housing Unit Alternative with an Amusement Park; an Off-Site Location Alternative; and an alternative with Measures to Reduce Automobile Ownership.

A. NO PROJECT ALTERNATIVE

CEQA Guidelines Section 15126.6 requires that the EIR evaluate a No Project Alternative. The purpose of the No Project Alternative is to allow decision-makers to compare the effects of the Proposed Project with the effects of taking no action.

CEQA Guidelines Section 12126.6(e)(3) requires that the No Project Alternative compare the environmental effects of the Proposed Project to the effects of Project Area remaining in its existing state under current conditions (i.e., the environmental setting). This analysis must take into account any predictable actions by others that could proceed without the Proposed Project being approved. It should also consider environmental effects that would reasonably be expected to occur in the foreseeable future if the Proposed Project were not approved.

NO PROJECT ALTERNATIVE ASSUMPTIONS

Disposal of Treasure Island and Yerba Buena Island are subject to several Federal laws and regulations,² including the Defense Base Closure and Realignment Act ("BRAC"), affecting the disposition of surplus real property (collectively the "Reuse Laws"). The Reuse Laws provide procedures for property reuse and disposal in the absence of adoption of a reuse plan by the local redevelopment authority (the "LRA") which, in this case, is the Treasure Island Development Authority ("TIDA").

Among other requirements, the Reuse Laws require the Federal Department of Housing and Urban Development ("HUD") to identify suitable sites that can be used to assist the homeless. The Navy may convey property identified by HUD for homeless use either directly to the homeless representative or to TIDA to manage such uses in the absence of a reuse plan. Therefore, whether or not the property were to be conveyed to TIDA, the No Project Alternative would likely include a continuation of current homeless assistance activities managed by the Treasure Island Homeless Development Initiative ("TIHDI"), a coalition of non-profit and social service and homeless service organizations.

² Federal Property and Administrative Services Act of 1949, as amended, 40 United States Code ("U.S.C."), Section 471 *et seq.*; the Surplus Property Act of 1944, 50 U.S.C. App. 1622 (g); Federal Property Management Regulations, 41 C.F.R. Chapter 101; the Base Closure Community Redevelopment and Homeless Assistance Act of 1994; and the 1994 Defense Authorization Act and other laws and regulations, including Title 10 of the U.S. Code and Navy regulations.

In addition, the Reuse Laws provide that bases subject to closure under BRAC are made available to other Federal agencies for their use before conveyance to an LRA. In the case of Treasure Island, the Federal Department of Labor exercised its rights under the Reuse Laws and requested facilities to operate its Jobs Corps Program on Treasure Island. The U.S. Coast Guard also requested approximately 48 acres plus water area and the Federal Highway Administration (“FHWA”) requested approximately 18 acres for facilities on Yerba Buena Island. The No Project Alternative, therefore, includes the Job Corps, Coast Guard, and FHWA sites at their current locations.

The Reuse Laws also require the military authority to make the property available to other Federal agencies subject to certain terms and conditions. In the absence of any Federal agency users, the Navy may convey the property to the LRA, State, or other public agencies, or to other private purchasers. In this particular case, conveyance to other State or local public agencies or private purchase would subject the property to the Tidelands Trust Doctrine, which will apply to Treasure Island once the property leaves Federal ownership. State law generally prohibits conveyance of Public Trust property to private parties and currently designates TIDA as the trustee for the Public Trust on Treasure Island and Yerba Buena Island.³

Because of the wide array of possible outcomes, it would be too speculative to predict any particular reuse or conveyance scenario should the Proposed Project not proceed. The likely outcome would be that the Area Plan and Special Use District (“SUD”) would not be adopted, and that the Navy would dispose of the property to one or more Federal agencies subject to the Reuse Laws. Thus, the EIR assumes that under the No Project Alternative, uses similar to the current ones carried out under the existing Cooperative Agreement between the Navy and TIDA would continue. Under this agreement, TIDA, acting through and by various City agencies such as the San Francisco Public Utilities Commission (“SFPUC”) and Department of Public Works, operates and maintains the buildings and grounds of the former Naval Station Treasure Island (“NSTI”), and would likely continue to do so until such a time as the property were disposed of by the Navy subject to the Reuse Laws. It is also assumed that the City and County of San Francisco would continue to provide police and fire services on the Islands.

DESCRIPTION

As discussed above, the analysis of the No Project Alternative assumes that the Project Area would likely remain in its existing condition. Approximately 404 acres of land on Treasure Island and approximately 95 acres of land on Yerba Buena Island, formerly NSTI,

³ Under the Treasure Island Conversion Act of 1996 (Assembly Bill 699, amending California Health and Safety Codes Sections 33492.5 and adding Section 2.1 to Chapter 1333, Statutes of 1968), TIDA was granted the authority to administer and control Tidelands Trust property located on or about NSTI.

would not be conveyed by the Navy to TIDA, and would not be subject to the Conveyance Agreement between the Navy and TIDA. Treasure Island and Yerba Buena Island would not be converted from a former naval military base and redeveloped into a dense, mixed-use development with residential, commercial, cultural, hotel, retail, and park and open space uses supported by a Ferry Terminal, intermodal Transit Hub, and new and/or upgraded public services and utilities. TIDA would not implement the Proposed Project, including the proposed Area Plan/SUD or Development Program.

With the No Project Alternative, the exchange of land from Treasure Island to Yerba Buena Island authorized by the Conversion Act of 1996⁴ would not occur. Existing uses, including interim leasing of existing buildings, would remain, managed either by TIDA under the existing Cooperative Agreement,⁵ which would be subject to annual renewal by the Navy and TIDA, or by the Navy as the owner of the property until an alternative reuse plan were developed and/or the property was conveyed by the Navy subject to the Reuse Laws.

As with the Proposed Project, the No Project Alternative would continue existing land ownership by the U.S. Department of Labor and FHWA on behalf of Caltrans. Approximately 37 acres of land would continue to be occupied by the U.S. Department of Labor for its existing Job Corps Program on Treasure Island, and approximately 18 acres would remain under the jurisdiction of FHWA/Caltrans for construction of the east span of the San Francisco-Oakland Bay Bridge, expected to be completed in 2013. The U.S. Coast Guard would continue to occupy 48 acres on the south and east sides of Yerba Buena Island.

Existing uses within the proposed Development Plan Area on Treasure Island and Yerba Buena would remain. These existing uses include about 1,005 dwelling units, of which about 805 units would continue to be available for occupancy. About 100 buildings suitable for occupancy with existing non-residential uses, in addition to existing parking, roadways, and open space, would continue to be used on the Islands. The existing buildings, whether vacant or occupied, would not be demolished. The existing wastewater treatment facility and other infrastructure would remain to support these uses. Either TIDA under the existing Cooperative Agreement, or the Navy in the event the Cooperative Agreement were to be terminated, would be responsible for the maintenance, operation, and leasing of real property and open space on Treasure Island and Yerba Buena Island, including maintenance of the designated historic Buildings 1, 2, and 3 on Treasure

⁴ Under the No Project Alternative, NSTI would no longer be subject to the Treasure Island Conversion Act of 1996 which authorized the City and County of San Francisco to establish TIDA as the redevelopment agency (i.e., Local Reuse Authority) with jurisdiction over the redevelopment of NSTI.

⁵ On October 1, 1997, concurrent with the operational closure of Treasure Island Naval Station, the City entered into a Cooperative Agreement with the U.S. Navy in which the City agreed to take responsibility for caretaker services on Treasure Island and Yerba Buena Island. TIDA, acting on behalf of the City, would continue to assume this responsibility. The agreement is subject to annual renewal.

Island, and the Nimitz House, the Senior Officers' Quarters Historic District, Quarters 10, Building 267, and the Torpedo Assembly Building on Yerba Buena Island.

The No Project Alternative assumes that TIHDI would continue to manage and lease approximately 250 units and have the ability to lease up to 375 units on the Islands under the existing homeless assistance plan approved by HUD in 1996.

With the No Project Alternative, there would be no new construction within the Development Plan Area of up to 8,000 dwelling units, 140,000 square feet of new commercial and retail space, 100,000 sq. ft. of office space, and 500 hotel rooms. Historic Buildings 1, 2, and 3 on Treasure Island would not receive historic rehabilitation and be adapted to house new commercial and entertainment space, nor would the buildings in the Senior Officers' Quarters Historic District on Yerba Buena Island be adapted for reuse as hotel, community, and public service space. Approximately 300 acres of new and enhanced local and regional open space and parks would not be created on the Islands.

The Project Area would remain in the existing P (Public Use) District and 40-X height and bulk districts, and no amendments to the *San Francisco General Plan* and Planning Code would be required. Related documents, such as a *Design for Development*, would not be adopted. Under the No Project Alternative, a Habitat Management Plan would not be implemented for Yerba Buena Island. Unlike with the Proposed Project, a Sustainability Plan would not be implemented under this alternative. No renewable energy sources would be developed to offset energy demand from the existing uses.

The No Project Alternative would not include stabilization of Treasure Island for geotechnical purposes. It would not include stabilization and re-grading to address flood protection and potential sea level rise. There would be no major infrastructure upgrade; the existing wastewater collection and treatment facilities and stormwater collection facilities would remain in place. No new bicycle or pedestrian facilities would be constructed. The proposed Ferry Terminal and breakwaters would not be constructed. Dredging for the ferry basin would not occur.

The Navy would be responsible for completing its remediation responsibilities under the requirements of the Comprehensive Environmental Response and Liability Act (“CERCLA”) and the Petroleum Program. The clean-up activities that would be completed would generally entail clean-up and closure of all active sites (information on the active sites is provided in Section IV.P, Hazards and Hazardous Materials). Under the No Project Alternative, it is assumed that the Navy would complete this process in accordance with existing, adopted clean-up plans; however, no additional remediation activities would occur.

There would be no new transit service to the East Bay under the No Project Alternative. Current service provided by the San Francisco Municipal Railway (“Muni”) line 108-Treasure Island,

between the Islands and the Transbay Terminal in San Francisco, would continue. There would be no new ferry service introduced between the Islands and the San Francisco mainland. If approved by TIDA in the future, the proposed redevelopment of the marina at Clipper Cove and its expansion to 400 slips could be constructed, as defined in the 2005 *Transfer and Reuse of Naval Station Island Final EIR*. Although the landside improvements for the expanded marina are currently not being pursued, these facilities could still be constructed independent of the Proposed Project under the 2005 EIR. With the No Project Alternative, the landside services and waterside launch facilities at the existing Treasure Island Sailing Center would not be constructed, although the Treasure Island Sailing Center would continue in its existing location.

The No Project Alternative would not further any of the project sponsors' objectives, presented in Chapter II, Project Description, Section II.B, Project Sponsors' Objectives, p. II.4.

ENVIRONMENTAL ANALYSIS

Land Use and Land Use Planning

Under the No Project Alternative, the existing land uses on Treasure Island and Yerba Buena Island as described in the Setting discussion in Section IV.A, Land Use and Land Use Planning, would remain. This alternative would not result in new, dense mixed-use development on currently underused land. The existing retail, office, and educational uses, and the public services (police and fire) would remain. The existing temporary film and television production, music festivals, and other short-term public and private events could continue. The land use impacts described in Section IV.A for the Proposed Project, all less than significant, would not occur. Therefore, as with the Proposed Project, there would be no significant land use impacts under the No Project Alternative.

Aesthetics

Under the No Project Alternative, existing visual conditions described in the Setting discussion in Section IV.B, Aesthetics, would continue for the foreseeable future. The significant and unavoidable adverse impact under the Proposed Project related to scenic vistas would not occur and no mitigation would be required. The less-than-significant impacts related to scenic resources, visual quality, and light and glare described in that section for the Proposed Project would not occur and no mitigation measures would be required.

Population and Housing

Under the No Project Alternative, there would be no new residents or new employment introduced to the Islands. Therefore this alternative would not result in increased population attributable to the Proposed Project, nor would it displace housing or create a demand for new

housing. There would continue to be approximately 1,820 persons residing in the 805 habitable units within the Project Area, as described in the Setting discussion in Section IV.C, Population and Housing. Under the No Project Alternative, all existing non-residential land uses would remain as they are under existing conditions. The existing spaces occupied by retail, office, schools, public services (police and fire), recreational uses (including the Sailing Center), and maintenance of these uses would continue to generate around 320 jobs. The impacts related to population and housing described in Section IV.C, Population and Housing, for the Proposed Project, all less than significant, would not occur.

Cultural and Paleontological Resources

Under the No Project Alternative, existing conditions described in the Setting discussion in Section IV.D.1, Archeological and Paleontological Resources, would continue. The potential impacts on cultural and paleontological resources described in that section for the Proposed Project, all less than significant with mitigation, would not occur, and no mitigation measures would be required.

Also under the No Project Alternative, existing conditions described in the Setting discussion in Section IV.D.2, Historic Architectural Resources, would continue for the foreseeable future. Historic Buildings 1, 2, and 3 would continue to be used for temporary activities such as film production and would not be rehabilitated for long-term reuse. Nor would the Senior Officers' Quarters and Torpedo Assembly Building be rehabilitated for reuse. The *U.S.S. Buttercup*, an historical resource under CEQA, would not be demolished. Therefore, a significant unavoidable impact on this historical resource resulting from demolition of the *U.S.S. Buttercup* under the Proposed Project would not occur, and no mitigation measures would be required.

Transportation

Under the No Project Alternative, no existing buildings would be demolished or new buildings constructed. The No Project Alternative would not result in additional travel demand on the Islands. As a result, the No Project Alternative would result in transportation impacts less than those of the Proposed Project with regard to traffic, transit, bicycle, pedestrian, loading, emergency access, and construction. In contrast to the Proposed Project, the No Project Alternative would not result in any new trips that would create or contribute to impacts on the ramps, the intersections, or transit. Additionally, the No Project Alternative would not result in significant construction impacts. No mitigation measures are required under this alternative.

Noise

Under the No Project Alternative, no new land uses would be developed and, thus, no construction activities would occur. There would be no pile driving, deep dynamic compaction,

vibro-compaction, truck trips or construction equipment activity. Consequently, there would not be any significant construction-related noise impacts under the No Project Alternative.

With this alternative, the intermodal Transit Hub with its associated ferry trips and East Bay bus service would not be developed and there would be no noise impacts from ferry and bus service.

Local roadway traffic volumes would increase slightly in the future as the result of a previously studied marina expansion project. However, the increase in roadway noise generated by the expansion was addressed in the 2005 *Transfer and Reuse of Naval Station Island Final EIR* and would not be considered an impact of the Proposed Project or the No Project Alternative. There would be no increased operational noise impacts under the No Project Alternative. For this reason, the No Project Alternative would avoid the significant noise impacts that would result from implementation of the Proposed Project, including significant and unavoidable construction- and traffic-related noise impacts.

Air Quality

Under the No Project Alternative, no new land uses would be developed and, therefore, no construction activities would occur. There would be no pile driving, deep dynamic compaction, vibro-compaction, truck trips, or construction equipment activity. Consequently, in comparison to the Proposed Project, there would be no construction-related air quality impacts with the No Project Alternative.

Under this alternative, the intermodal Transit Hub with its associated ferry trips and East Bay bus service would not be developed, and there would be no air quality impacts from the ferry service.

Regional trip generation and its associated emissions would be increased slightly in the future if the marina expansion at Clipper Cover were to be approved and constructed. The increase in emissions generated by the expansion was addressed in the 2005 *Transfer and Reuse of Naval Station Island Final EIR* and would not be considered an impact of the Proposed Project or the No Project Alternative. As such, there would be no operational air quality impacts under the No Project Alternative.

Greenhouse Gases

Under the No Project Alternative, no construction would occur. There would be no pile driving, deep dynamic compaction, vibro-compaction, truck trips or construction equipment activity. Consequently, there would not be any significant construction-related greenhouse gas (“GHG”) impacts under the No Project Alternative.

In addition, under this alternative, there would be no new land uses developed. There would be no operational GHG impacts under the No Project Alternative. The Transit Hub with its

associated ferry trips and new East Bay bus service would not be developed, and there would be no GHG emissions generated by the Transit Hub. In summary, the less-than-significant GHG emissions impacts that would result from implementation of the Proposed Project would not occur with the No Project Alternative, and no mitigation is required.

Regional trip generation and the associated emissions would increase slightly in the future as a result of the marina expansion reviewed in the *2005 Transfer and Reuse of Naval Station Treasure Island Final EIR*, if approved by TIDA. However, the increase in GHG emissions generated by this expansion would be very small compared to emissions estimated for the Proposed Project, and would not result in significant cumulative impacts.

Wind and Shadow

Under the No Project Alternative, the existing shadow conditions would not change. There would be no new shadowing of existing open spaces, parks, or recreation areas on Treasure Island or Yerba Buena Island as there would be under the Proposed Project. Since there would be no new open spaces, parks, or recreation areas under the No Project Alternative, there would be no new shadowing of such spaces.

Under the No Project Alternative, the existing wind conditions, which are described under Setting in Section IV.I.2, Wind, would not change. Based on the wind tunnel test results described under Impacts in Section IV.I.2, implementation of the Proposed Project would result in an overall improvement in wind conditions, i.e., fewer wind hazards and fewer hours of hazardous winds, due to the sheltering effect of the proposed buildings. Therefore, the wind conditions under the Proposed Project would represent an overall improvement over the wind conditions under the No Project Alternative.

Recreation

There are currently approximately 170 acres of parks and open space on the Islands (approximately 90 acres on Treasure Island and 80 acres on Yerba Buena Island). In comparison to the Proposed Project, this alternative would provide substantially less open space, since approximately 300 acres of new and enhanced local and regional open space and parks would not be created within the Development Plan Area. Under the No Project Alternative, the existing recreational space and open space, including the various playing fields on Treasure Island, would continue to be available to San Francisco and Bay Area residents. However, the No Project Alternative would not help to reduce the existing shortage of regional field facilities, as the 25- to 40-acre Sports Park would not be developed. The less-than-significant impacts on recreation described in Section IV.J, Recreation, for the Proposed Project would not occur.

Utilities and Service Systems

Under the No Project Alternative, no new or upgraded wastewater, recycled water, stormwater, water supply, electricity, natural gas, or telecommunications infrastructure would be installed. Unlike the Proposed Project, construction impacts, such as noise and dust, associated with replacement utilities would not occur.

The existing wastewater collection and treatment system would continue to provide treatment under the National Pollutant Discharge Elimination System (“NPDES”) permit. Stormwater would continue to be managed under the Municipal Separate Storm Sewer System General Permit. Under the No Project Alternative, untreated stormwater would continue to be discharged to the Bay. In comparison, the Proposed Project would treat stormwater discharge as required by SFPUC and Regional Water Quality Control Board (“RWQCB”); therefore, water quality impacts associated with discharging untreated water into the Bay would not be reduced in the No Project Alternative.

With the No Project Alternative, the SFPUC would implement repairs and upgrades to the existing wastewater and stormwater systems as necessary to keep the systems operational. No water recycling would occur.

Demand for potable water would not increase as it would under the Proposed Project. The existing water supply system would continue to operate, and would be repaired and upgraded as needed. No new potable water storage tanks would be installed.

There would not be increased solid waste generation. There would be no increase in energy demand. Existing electricity, natural gas, and telecommunications infrastructure would continue to operate, and would be repaired and upgraded as necessary.

In summary, as with the Proposed Project, there would be no significant environmental impacts associated with operating the utilities and service systems under the No Project Alternative, and no mitigation measures would be required.

Public Services

Under the No Project Alternative, the existing police and fire stations would not be replaced by a larger, more modern combined station. Since the number of residents and employees would not increase, the number of police officers and firefighters would not be expected to change. Response times for both police and fire services would be unchanged.

The No Project Alternative would not result in the need for new emergency medical services on the Islands or new firefighting equipment. The supplemental water supply system that would provide recycled water for firefighting would not be constructed, and the system that would

provide access for fireboats using seawater would not be put in place. More fire-resistant structures would not be built. Demand for fire protection would not be expected to increase.

Existing educational programs would be likely to continue leasing space on Treasure Island, including the Glide YouthBuild Program, the Life Learning Academy, the Child Development Center, and the SFPD motorcycle training unit. The Treasure Island School would not be renovated nor rebuilt and re-opened as a public elementary school; thus, existing school children residing on the Islands would continue to attend schools off-island, and there would be no new demand for public school facilities. Similarly, there would be no new demand for hospital services or public library facilities, as there would be no measurable increase in residential or employee population under this alternative.

In summary, the less-than-significant impacts on public services discussed in Section IV.L, Public Services, for the Proposed Project would not occur under the No Project Alternative.

Biological Resources

Unlike the Proposed Project, the No Project Alternative would not result in any of the direct terrestrial or offshore biological impacts analyzed in this EIR regarding land conversion, infrastructure development (including the Ferry Terminal), geotechnical stabilization, and storm water pond runoff. Therefore, the No Project Alternative would avoid significant impacts on biological resources, including significant and unavoidable impacts on rafting waterfowl due to ferry operations. The mitigation measures identified to reduce impacts from constructing and operating the ferry service would not be necessary.

The draft *Habitat Management Plan* for Yerba Buena Island would not be implemented as part of the Proposed Project, and its potential for the improvement of habitat structure, biodiversity, and stability on Yerba Buena Island would not be realized. Over the longer term, the lack of habitat preservation and native plant management would result in increasing degradation of the remaining natural areas on Yerba Buena Island, which could adversely impact habitat structure, biodiversity, and stability on Yerba Buena Island. In this respect the No Project Alternative would have greater impacts on terrestrial biological resources than would the Proposed Project; existing conditions on the island represent a CEQA baseline already ecologically compromised, and the difference would not be significant.

Geology and Soils

The No Project Alternative would not include geotechnical stabilization efforts on the Islands that would occur with the Proposed Project. Thus, existing seismic risks to residents, workers, and visitors related to geotechnical stabilization on the Islands would remain.

Hydrology and Water Quality

The Project Area would remain in its existing condition. No new construction would occur, and there would be no changes in impervious surfaces or drainage. Existing flooding conditions would remain. With the No Project Alternative, untreated stormwater runoff would continue to be discharged into the Bay, and there would be no long-term adaptive management strategy to protect Treasure Island from potential flooding due to future potential sea level rise. However, overall, the No Project Alternative would have fewer less-than-significant impacts on hydrology and water quality than the Proposed Project, as there would be no adverse effects associated with disposal of groundwater during construction.

Hazards and Hazardous Materials

With the No Project Alternative, the Navy would continue to be responsible for completing its remediation responsibilities under the requirements of CERCLA and the Petroleum Program; however, no additional remediation activities would occur. With less overall disturbance of subsurface materials, there would be less potential for discovery of previously unknown contamination which could remain as a potential source of groundwater contamination. Otherwise, the No Project Alternative would generally not increase the routine use, storage, and transport of hazardous materials, and would have fewer less-than-significant impacts on hazards than the Proposed Project.

Mineral and Energy Resources

Under the No Project Alternative, demand for electricity, natural gas, heating, or cooling would not increase, as it would if the Proposed Project were implemented. As with the Proposed Project, there would be no significant environmental impacts associated with mineral and energy resources.

The energy efficiencies that would be introduced by energy conservation measures under the Proposed Project would not occur. In addition, no new renewable energy sources, such as solar photovoltaic panels, would be developed to offset energy demand from the existing uses.

Agricultural Resources and Forest Land

Informal harvesting of olives for olive oil would continue under the No Project Alternative. The 20-acre Urban Agricultural Park would not be created, and there would not be opportunities for agricultural-related educational, training, or employment programs. As with the Proposed Project, there would be no rezoning or conversion of designated farmland or timberland, and, similar to the Proposed Project, impacts on agricultural resources and forest land would be less than significant.

B. REDUCED DEVELOPMENT ALTERNATIVE

DESCRIPTION

Under the Reduced Development Alternative (see Figure VII.1: Reduced Development Alternative), the former NSTI lands would be conveyed to TIDA, as they would with the Proposed Project. The basis for the Reduced Development Alternative is the program that was included in the *Development Plan and Term Sheet for the Redevelopment of Naval Station Treasure Island* (the “2006 Term Sheet”) endorsed by TIDA in October 2006 and by the Board of Supervisors in December 2006, but without the 2010 Development Plan Update endorsed by TIDA and the Board of Supervisors in 2010.⁶ The 2006 Term Sheet was prepared along with supporting studies that addressed project design concepts, transportation, infrastructure, sustainability, community services, affordable housing, jobs, and other aspects of the development.

The primary difference between the Proposed Project and the Reduced Development Alternative is that residential development would be reduced from up to 8,000 dwelling units to 6,000 units. There would be no office space in the Reduced Development Alternative. With fewer residential units and no office space, the total number of parking spaces would be reduced by approximately 1,720 spaces. Table VII.2 summarizes the key differences in land use.

● **Table VII.2: Key Land Use Differences - Proposed Project and Reduced Development Alternative**

Land Use	Proposed Project	Reduced Development Alternative
Residential	8,000 units	6,000 units
Office	100,000 sq. ft.	0
Parking	10,675 spaces	8,955 spaces

Source: Turnstone Consulting, April 2010

Although the total amount of retail space in this alternative would be the same as the Proposed Project’s, the portion of the retail space that would likely be “neighborhood-serving,” such as coffee shops, banks, hardware stores, and dry cleaners, would be reduced by approximately 25 percent because there would be fewer residents to support neighborhood-serving retail uses. As a result, unless the neighborhood-serving retail was subsidized, the Reduced Development Alternative would likely provide more square footage dedicated to regional-serving retail uses than would the Proposed Project. The Reduced Development Alternative differs from the

⁶ The Update to the *Development Plan and Term Sheet for the Redevelopment of Naval Station Treasure Island* was endorsed by the TIDA Board in April 2010 and by the Board of Supervisors in May 2010.



- Wireframe heights reflect heights shown in Figure II.6a: Treasure Island Maximum Height Limit Plan
- Existing buildings to be retained
- Proposed buildings

Towers can move within their respective wireframe boxes.
 Towers cannot exceed the heights indicated by their respective wireframe boxes.

SOURCE: Perkins+Will

development plan contained in the 2006 Term Sheet in that it includes the same amount of retail space as the Proposed Project, which is approximately 28,000 sq. ft. less than the 235,000 sq. ft. that was included in the 2006 Term Sheet.

Similar to the Proposed Project, the Reduced Development Alternative would include the rehabilitation and adaptive reuse of historic Buildings 1, 2, and 3 with up to 311,000 sq. ft. of commercial space and entertainment on Treasure Island. As with the Proposed Project, the historic Nimitz House, the Senior Officers' Quarters Historic District (the Great Whites), and the Quarters 10, Building 267, and historic Torpedo Assembly Building on Yerba Buena Island would be rehabilitated and adaptively reused for hotel and other visitor-serving uses.

As with the Proposed Project, the Reduced Development Alternative would include a new joint police/fire station and the existing school would either be upgraded or replaced. New and/or upgraded public utilities would be provided, including a water distribution system, wastewater collection and treatment, recycled water plant, and stormwater collection and treatment. This alternative would make use of the same method of geotechnical stabilization as the Proposed Project; in this regard, the alternative differs from the 2006 Term Sheet, which proposed a different geotechnical approach. The 2006 Term Sheet proposed shoreline stabilization of a 50-foot-wide strip around the perimeter of Treasure Island by installing stone columns, raising the perimeter berm, making ground improvements to the interior in two utility and emergency access corridors, and providing for appropriate foundations. The original stabilization approach would have involved construction activities in the water adjacent to the Treasure Island shoreline, unlike the Proposed Project.

As with the Proposed Project, there would be approximately 300 acres of parks and public open space on Treasure Island and Yerba Buena Island, and a Habitat Management Plan would be implemented for much of the undeveloped portions of Yerba Buena Island. Also similar to the Proposed Project, the Reduced Development Alternative would include new bicycle, transit, and pedestrian facilities, improved transit service and a new Ferry Terminal and intermodal Transit Hub on Treasure Island. The Reduced Development Alternative analyzes conditions both with and without implementation of Mitigation Measure M-TR-2 (Expanded Transit Service), as described in Section IV. E, Transportation, pp. IV.E.74-IV.E.75.⁷ Approval of a system of ramp meters at the Bay Bridge on-ramps would continue to be needed if the ramp meters were located on Caltrans property, and congestion pricing would still be implemented.

⁷ Mitigation Measure M-TR-2 (Expanded Transit Service) includes, but is not limited to: (1) additional ferry service to reduce peak period headways from 50 minutes to as low as 15-minute headways during the AM and PM peak periods; (2) increased frequency on Muni line 108-Treasure Island service to reduce peak period headways from 15 minutes to as low as 7-minute headways in the AM peak period and as low as 5 minutes in the PM peak period; and (3) new bus service to another location in San Francisco (e.g., to the San Francisco Civic Center area) with frequencies as low as 12 minutes during the AM and PM peak periods. Service shall be provided between approximately 5 AM and 10 PM.

The same Tidelands Trust Doctrine and statutory trust created by the Treasure Island Conversion Act of 1996, collectively referred to as the Tidelands Trust⁸ as described for the Proposed Project, would be necessary to implement the Reduced Development Alternative. As under the Proposed Project, the *San Francisco General Plan* and the Planning Code would be amended, and an Area Plan/SUD and *Design for Development* would be adopted. All other approvals listed for the Proposed Project would be necessary to implement the Reduced Development Alternative.

- The Reduced Development Alternative was included to evaluate if reducing the number of residential units on Treasure Island would avoid or substantially lessen traffic (and related air quality and noise) impacts, as well as reduce an aesthetic impact on scenic vistas of the Proposed Project.

The Reduced Development Alternative could feasibly further most of the objectives of the project sponsors, presented in Section II.B, Project Sponsors' Objectives. However, fewer residential units under this alternative (25 percent fewer than the Proposed Project) could reduce some of the economic advantages and efficiencies that a higher density residential development would provide in order to achieve key project objectives (e.g., providing public amenities, infrastructure and transportation improvements; providing affordable housing; providing new and enhanced parks and open space; and creating a community of sufficient size to support neighborhood-serving retail, community facilities, and transit).

ENVIRONMENTAL ANALYSIS

Land Use and Land Use Planning

The land use impacts of the Reduced Development Alternative would be less than significant, and similar to those described for the Proposed Project in Section IV.A, Land Use and Land Use Planning. The same types of land uses would be developed under this alternative; however, development would be less dense, with 2,000 fewer residential units and no new office space. Also, the Reduced Development Alternative would have a smaller proportion (25 percent less) of neighborhood-serving retail uses. Like the Proposed Project, the Reduced Development Alternative would not physically divide an established community, would not have a substantial adverse impact on the character of the vicinity, and would not have a substantial adverse impact on the character of land uses subject to the Tidelands Trust Doctrine. The Reduced Development Alternative would not result in any new significant land use impacts.

⁸ The Treasure Island Conversion Act of 1996 (Assembly Bill 699, amending California Health and Safety Codes Sections 33492.5 and adding Section 2.1 to Chapter 1333, Statutes of 1968).

Aesthetics

Under the Reduced Development Alternative, impacts related to aesthetics would be similar in character to those described for the Proposed Project in Section IV.B, Aesthetics, but potentially lessened somewhat in magnitude given the overall reduced density of new construction under this alternative.

There would likely be fewer towers on Treasure Island under this alternative (about four fewer towers than the 19 towers under the Proposed Project). These would likely be lower in height and spaced farther apart. As with the Proposed Project, this alternative would continue to result in a prominent cluster of high-rise buildings at the center of San Francisco Bay. It would be particularly prominent from public vantage points along the eastern shoreline of San Francisco, Telegraph Hill, and the East Bay shoreline, and from the Bay Bridge east span. Implementation of this alternative would lessen, but not avoid, a significant impact on scenic vistas compared to the Proposed Project.

As with the Proposed Project, a *Design for Development* would be implemented to establish specific requirements for buildings, streets, open spaces, landscaping to encourage high-quality design and materials, an inviting pedestrian-orientation, and visual variety and interest. As with the Proposed Project, impacts related to visual quality under this alternative would be less than significant, and no mitigation measures would be required.

Impacts related to light and glare and scenic resources would be similar in character to those described for the Proposed Project. As with the Proposed Project, impacts related to scenic resources and light and glare for the Reduced Development Alternative would be less than significant, and no mitigation measures would be required.

Population and Housing

Under the Reduced Development Alternative, the number of residential units would be reduced to 6,000 (2,000 fewer units than under the Proposed Project). There would also be no office space under this alternative. Other land uses would be identical to the Proposed Project, except the proportion of neighborhood-serving retail space would be reduced by about one-quarter. Under the Reduced Development Alternative, there would be a total residential population of 13,980 people by 2030 (about 4,550 fewer people than with the Proposed Project). Like the Proposed Project, it would increase the existing area-wide population, although the increase would not be beyond expected growth incorporated into local and regional planning efforts and housing and planning forecasts.

Under the Reduced Development Alternative, non-residential land uses would be the same as those included in the Proposed Project, except that no office space would be constructed. With

this alternative, there would be 360 fewer employees than the Proposed Project, resulting in a total of 2,560 employees and 2,240 net new employees. Like the Proposed Project, employment under the Reduced Development would not create a substantial demand for housing in this neighborhood, San Francisco, or the region in excess of the housing provided as part of the alternative or housing otherwise available in the Bay Area. The amount of housing provided by the Reduced Development Alternative would continue to exceed demand generated by project-generated employees. Therefore, impacts on population and housing would be less than significant under this alternative, as with the Proposed Project, and no mitigation measures would be required.

Cultural and Paleontological Resources

Under this alternative, impacts related to archaeological and paleontological resources would be similar in character to those described for the Proposed Project in Section IV.D.1, Archaeological and Paleontological Resources. The same or similar ground-disturbing, geotechnical stabilization work would take place under this alternative as described for the Proposed Project in Chapter II, Project Description. Roughly the same area of ground would be disturbed, although the depth of ground disturbance could potentially be reduced somewhat, given potentially shallower foundations and a reduced number of off-street structured parking spaces required for this alternative. The same mitigation measures identified for the Proposed Project would apply to this alternative to reduce potential impacts of this alternative on archaeological and paleontological resources to a less-than-significant level.

Under Alternative B, impacts related to historic architectural resources would be identical to those described for the Proposed Project in Section IV.D.2, Historic Architectural Resources. Like the proposed project, this alternative would result in a significant and unavoidable impact on the *U.S.S. Buttercup*, an historical resource.

Transportation

The Reduced Development Alternative would include the same transportation improvements as the Proposed Project, as described in Section IV.E, Transportation, beginning on p. IV.E.30. The Reduced Development Alternative would include the same roadway network as the Proposed Project, and the developed area would be on the same footprint.

With the Reduced Development Alternative, the number of residential units would be 6,000 compared with 8,000 units included in the Proposed Project, and the 100,000 square feet of office space included as part of the Proposed Project would not be constructed. The Reduced Development Alternative would include approximately 2,000 fewer parking spaces than the Proposed Project. All other uses would be the same as those for the Proposed Project. Therefore, compared to the Proposed Project, the Reduced Development Alternative would generate fewer

person and vehicle trips. Table VII.3 summarizes the project travel demand for the Proposed Project and the Reduced Development Alternative. Additional discussion of the Reduced Development Alternative travel demand and impact assessment is included in the *Transportation Impact Study*, in Appendix C to this EIR.

Table VII.3: Person-Trip Generation by Mode – Proposed Project and Reduced Development Alternative

Peak hour	Person-Trip Generation ¹				Vehicle-Trips ²
	External			Internal	
	Ferry	Bus	Auto	Other ³	
<i>Proposed Project</i>					
AM	641	621	3,391	3,296	1,613
PM	817	898	5,124	4,850	2,462
Saturday	473	595	5,913	5,743	2,861
<i>Reduced Development Alternative</i>					
AM	522	486	2,748	2,745	1,294
PM	696	766	4,652	4,240	2,218
Saturday	426	527	5,321	5,164	2,565

Notes:

¹ This analysis assumes no external pedestrian or bicycle trips onto or off of the Islands. With construction of the new east span bicycle/pedestrian path, it is possible that some bicycle trips may occur. However, this number is expected to be very minor and not likely to affect the overall conclusions of this study. Further, the potential new bicycle facility on the west span is still in the conceptual discussion phases, and is not assumed to be in place in this analysis.

² Vehicle-trips include passenger vehicles and vans.

³ Includes internal bicycle and pedestrian trips, and a relatively small number of internal auto trips (e.g., between Yerba Buena Island and Treasure Island).

Source: Fehr & Peers 2010

Construction

Construction activities associated with the Reduced Development Alternative would be similar, but somewhat reduced due to the lesser amount of overall construction for the Proposed Project. Mitigation Measure M-TR-1, a Construction Management Program, described in Section IV.E, Transportation, beginning on p. IV.E.69, would minimize the alternative's contribution to construction-related traffic impacts. However, some disruption and increased delays could still occur even with implementation of M-TR-1, and, as with the Proposed Project, construction-related traffic impacts would remain significant and unavoidable.

Traffic

The Reduced Development Alternative would result in between 240 and 320 fewer vehicle trips during the peak hours than the Proposed Project, with the greatest reduction during the AM peak

hour. As indicated in Table VII.4 and Table VII.5, the Reduced Development Alternative would have similar delays and LOS conditions as the Proposed Project. As with the Proposed Project, the Reduced Development Alternative would result in similar significant and unavoidable impacts related to extensive queues and vehicle delays at the following study ramp locations:

- At the eastbound off-ramp on the west side of Yerba Buena Island;
- Under conditions without the Ramps Project, at the two westbound on-ramps; and
- Under conditions with the Ramps Project, at the ramp meter at the westbound on-ramp at the east side of Yerba Buena Island.

Similar to the Proposed Project, under conditions without and with the Ramps Project, the Reduced Development Alternative would result in less-than-significant impacts at the eastbound on-ramp and eastbound off-ramp on the east side of Yerba Buena Island, and the westbound off-ramp on the east side of Yerba Buena Island. The Reduced Development Alternative would also result in a significant impact on queuing at the Bay Bridge toll plaza during the weekday AM peak hour, and on San Francisco streets approaching the Bay Bridge during the PM peak hour.

Table VII.6, p. VII.25, presents the comparison of intersection Levels of Service (“LOS”) for Existing, Existing plus Proposed Project, and Existing plus Reduced Development Alternative conditions. The results indicate that the Reduced Development Alternative would result in significant impacts at eight study intersections (compared with nine for the Proposed Project).

- The Reduced Development Alternative would result in project-specific impacts at six signalized study intersections that operate at LOS D or better under Existing conditions and would deteriorate to LOS E or LOS F under Existing plus Project conditions, or that operate at LOS E under Existing conditions and would deteriorate to LOS F under Existing plus Project conditions (First/Market, First/Mission, First/Folsom, First/Harrison/I-80 Eastbound On-Ramp, Bryant/Fifth/I-80 Eastbound On-Ramp, Fifth/Harrison/I-80 Westbound Off-Ramp).
- The Reduced Development Alternative would have less-than-significant contributions at four signalized study intersections that operate at LOS E or LOS F under Existing conditions and that would continue to operate at LOS E or LOS F under Existing plus Project conditions (First/Howard, Essex/Harrison/I-80 Eastbound On-Ramp, The Embarcadero/Harrison, and Second/Folsom).
- The Reduced Development Alternative would have less-than-significant contributions at five signalized study intersections that would operate at LOS D or better under Existing plus Project conditions.
- The Reduced Development Alternative would contribute considerably to two uncontrolled study intersections that operate poorly under Existing conditions, resulting in a project-specific impact (Folsom/Essex and Bryant/Sterling).

Table VII.4: Ramp Junction Analysis – Existing, Existing plus Proposed Project, and Existing plus Reduced Development Alternative

Ramp	Peak Hour	Existing		Existing plus Proposed Project		Existing plus Reduced Development Alternative	
		Ramp Merge	Stop-Controlled	Ramp Merge	Stop-Controlled ¹	Ramp Merge	Stop-Controlled ¹
		Density/LOS ²	Delay/LOS ³	Density/LOS ²	Delay/LOS ³	Density/LOS ²	Delay/LOS ³
<i>Ramp Junction LOS without Ramps Project</i>							
Eastbound On-Ramp (East side)	AM	22.3/C	74.2/F	24.1/C	N/A	23.7/C	N/A
	PM	27.8/C	> 80/F	26.3/C	N/A	25.9/C	N/A
	Sat	24.5/C	> 80/F	26.5/C	N/A	26.1/C	N/A
Eastbound Off-Ramp (West side)	AM	30.1/D	N/A	33.4/D	N/A	32.6/D	N/A
	PM	36.2/E	N/A	39.3/E	N/A	39.3/E	N/A
	Sat	32.3/D	N/A	39.7/E	N/A	39.4/E	N/A
Eastbound Off-Ramp (East side) ⁴	AM	N/A	N/A	26.6/C	N/A	26.2/C	N/A
	PM	N/A	N/A	30.4/D	N/A	30.4/D	N/A
	Sat	N/A	N/A	30.8/D	N/A	29.9/D	N/A
Westbound On-Ramp (West side)	AM	27.9/C	> 80/F	26.4/C	> 80/F	26.4/C	> 80/F
	PM	25.1/C	> 80/F	25.0/C	> 80/F	25.0/C	> 80/F
	Sat	24.6/C	> 80/F	23.8/C	> 80/F	23.8/C	> 80/F
Westbound On-Ramp (East side) ⁴	AM	N/A	N/A	27.3/C	> 80/F	27.3/C	> 80/F
	PM	N/A	N/A	26.4/C	> 80/F	26.4/C	> 80/F
	Sat	N/A	N/A	25.1/C	> 80/F	25.1/C	> 80/F
Westbound Off-Ramp (East side)	AM	32.8/D	N/A	32.5/D	N/A	32.1/D	N/A
	PM	29.4/D	N/A	32.6/D	N/A	32.1/D	N/A
	Sat	28.5/D	N/A	31.8/D	N/A	31.5/D	N/A
<i>Ramp Junction LOS with Ramps Project (on Reconstructed Westbound Ramps)</i>							
Westbound On-Ramp (East side) ⁵	AM	N/A	N/A	24.0/C	N/A	23.8/C	N/A
	PM	N/A	N/A	25.2/C	N/A	25.1/C	N/A
	Sat	N/A	N/A	29.6/D	N/A	28.4/D	N/A
Westbound Off-Ramp (East side)	AM	N/A	N/A	26.0/C	N/A	25.7/C	N/A
	PM	N/A	N/A	26.1/C	N/A	25.6/C	N/A
	Sat	N/A	N/A	25.4/C	N/A	25.1/C	N/A

Notes: LOS E and LOS F conditions highlighted in **bold**. N/A = Not Applicable

¹ Under conditions without the Ramps Project, existing stop-control would remain in place on both westbound on-ramps. Under these conditions, similar to the analysis of existing conditions, both the HCM merge analysis and the HCM stop-controlled intersection analysis were performed. There are no stop signs at the off-ramps; therefore, there is no analysis for these ramps in the “Stop-controlled” column.

² Density measured in passenger cars per mile per lane.

³ Delay measured in seconds per vehicle.

⁴ The eastbound off-ramp (east side) and westbound on-ramp (east side) were closed due to construction at the time the existing conditions data were collected, and therefore no ramp merge results are shown under the Existing column. Both ramps have since been reopened.

⁵ Under conditions with the Ramps Project, the westbound on-ramp (west side) is planned to be for transit and emergency vehicle access only. Thus, under conditions with the Ramps Project, ramp junction analysis was only performed for the westbound on-ramp (east side) because volumes would be very small on the westbound on-ramp (west side). Conditions at other YBI ramps would not change from those presented for conditions without the Ramps Project.

Source: Fehr & Peers 2010

Table VII.5: Maximum On-Ramp Queues and Average Delays – Existing plus Project and Existing plus Reduced Development Alternative Conditions

Peak hour	Existing plus Project miles (minutes:seconds)		Existing plus Reduced Development Alternative miles (minutes:seconds)	
	Existing Ramps ^{1,2,4}	With Ramps Project ¹	Existing Ramps ^{1,2,4}	With Ramps Project ¹
AM	0.45 (2:06)	1.23 (5:12)	0.47 (2:00)	0.64 (2:54)
PM	0.45 (2:06)	1.10 (4:54)	0.35 (2:00)	0.45 (2:42)
Saturday ³	0.68 (2:54)	0.00 (0:00)	0.61 (2:30)	0.00 (0:00)

Notes:

¹ Delays greater than 35 seconds per vehicle highlighted in bold.

² Includes planned reconstruction of the eastbound ramp on the east side of Yerba Buena Island as part of the Bay Bridge East Span project.

³ Ramp metering not assumed to be in operation during the Saturday peak hour.

⁴ Queues and delays presented for existing ramps are for each of the two ramps; traffic was assumed to split equally between the two.

Source: Fehr & Peers 2010

As with the Proposed Project, the traffic impacts at ramps and intersections would be minimized but not eliminated with implementation of Mitigation Measure M-TR-2 (Expanded Transit Service) as discussed in Section IV.E, Transportation, pp. IV.E.74-IV.E.75. This mitigation measure would reduce vehicle trip generation and would reinforce the proposed TDM practices included as part of the Reduced Development Alternative, including ramp metering, congestion pricing, etc. Aside from increasing transit, as proposed by Mitigation Measure M-TR-2, there do not appear to be other proven techniques that would achieve the desired mode shift.

Transit

The Reduced Development transit conditions assume implementation of Project-related transit improvements as described in Section IV.E., Transportation, p. IV.E.94. As for the Proposed Project, implementation of the Reduced Development Alternative would exceed the available

Table VII.6: Intersection Levels of Service – Existing and 2030 Cumulative Conditions

Intersection	Peak hour	Existing plus Project			Existing plus Reduced Development Alternative			2030 Cumulative plus Project			2030 Cumulative plus Reduced Development Alternative		
		Delay ¹	LOS ²	v/c	Delay ¹	LOS ²	v/c	Delay ¹	LOS ²	v/c	Delay ¹	LOS ²	v/c
1. Fremont/Howard	AM	19.2	B	0.81	18.8	B	0.80	47.3	D	1.04	44.8	D	1.03
	PM	46.3	D	0.99	46.2	D	0.99	>80	F	1.32	>80	F	1.35
	Sat	14.1	B	0.57	14.0	B	0.56	20.4	C	0.74	20.0	C	0.73
2. Fremont/Folsom	AM	30.4	C	0.71	30.4	C	0.71	>80	F	1.60	>80	F	1.59
	PM	24.5	C	0.46	24.5	C	0.45	33.2	C	0.64	34.0	C	0.69
	Sat	20.8	C	0.23	20.8	C	0.22	21.6	C	0.29	21.5	C	0.28
3. Fremont/I-80 WB Off-Ramp/Harrison	AM	11.0	B	0.39	11.0	B	0.38	>80	F	2.89	>80	F	2.89
	PM	29.5	C	0.86	29.3	C	0.85	35.1	D	0.92	36.9	D	0.96
	Sat	10.7	B	0.23	10.7	B	0.23	11.2	B	0.28	11.1	B	0.27
4. First/Market	AM	43.8	D	0.72	42.0	D	0.71	>80	F	1.12	>80	F	1.11
	PM	>80	F	0.91	>80	F	0.90	>80	F	1.14	>80	F	1.07
	Sat	28.0	C	0.61	26.2	C	0.61	55.0	E	0.71	51.6	E	0.70
5. First/Mission	AM	15.2	B	0.79	15.1	B	0.79	49.2	D	1.03	47.7	D	1.03
	PM	>80	F	0.94	>80	F	0.93	>80	F	1.24	>80	F	1.28
	Sat	21.1	C	0.75	20.9	C	0.75	26.3	C	0.84	25.5	C	0.84
6. First/Howard	AM	15.4	B	0.82	15.3	B	0.82	>80	F	1.39	>80	F	1.39
	PM	74.5	E	1.13	75.0	E	1.13	>80	F	2.19	>80	F	2.20
	Sat	19.3	B	0.48	19.4	B	0.48	15.9	B	0.66	15.5	B	0.65
7. First/Folsom	AM	12.0	B	0.53	12.0	B	0.53	19.1	B	0.83	19.1	B	0.83
	PM	>80	F	1.26	>80	F	1.25	>80	F	1.57	>80	F	1.64
	Sat	17.6	B	0.38	17.7	B	0.37	7.0	A	0.52	6.9	A	0.51
8. First /Harrison/I-80 EB On-Ramp	AM	28.4	C	0.66	28.5	C	0.65	26.7	C	0.87	26.5	C	0.87
	PM	>80	F	1.42	>80	F	1.40	>80	F	1.53	>80	F	1.61
	Sat	13.3	B	0.63	13.0	B	0.63	44.6	D	0.80	41.5	D	0.79
9. Essex/Harrison /I-80 EB On-Ramp ³	AM	7.5	A	0.39	7.5	A	0.39	18.2	B	0.71	18.3	B	0.71
	PM	>80	F	1.31	>80	F	1.30	>80	F	1.49	>80	F	1.54
	Sat	15.6	B	0.39	15.5	B	0.39	23.0	C	0.68	22.7	C	0.62
10. Second/Folsom	AM	13.5	B	0.51	13.5	B	0.51	>80	F	1.27	>80	F	1.27
	PM	68.0	E	0.99	67.0	E	0.99	>80	F	1.59	>80	F	1.63
	Sat	14.9	B	0.39	14.9	B	0.38	23.1	C	0.61	22.9	C	0.60

(continued)

Table VII.6 (continued)

Intersection	Peak hour	Existing plus Project			Existing plus Reduced Development Alternative			2030 Cumulative plus Project			2030 Cumulative plus Reduced Development Alternative		
		Delay ¹	LOS ²	v/c	Delay ¹	LOS ²	v/c	Delay ¹	LOS ²	v/c	Delay ¹	LOS ²	v/c
11. Second/Bryant	AM	11.1	B	0.38	11.2	B	0.38	41.1	D	0.76	40.2	D	0.76
	PM	32.8	C	0.92	32.8	C	0.92	63.0	E	1.15	69.0	E	1.17
	Sat	11.6	B	0.39	11.6	B	0.38	12.2	B	0.45	12.2	B	0.45
12. The Embarcadero / Harrison	AM	68.5	E	0.81	68.5	E	0.81	> 80	F	0.88	> 80	F	0.88
	PM	> 48.6	D	0.85	> 80	F	0.85	> 80	F	1.22	> 80	F	1.23
	Sat	12.2	B	0.40	12.2	B	0.40	15.0	B	0.52	15.0	B	0.52
13. Bryant /Fifth /I-80 EB On-Ramp ³	AM	23.5	C	0.58	23.3	C	0.58	> 80	F	1.27	> 80	F	1.27
	PM	> 80	F	1.74	> 80	F	1.73	> 80	F	2.51	> 80	F	2.59
	Sat	61.3	E	0.73	60.5	E	0.73	73.3	E	1.05	71.0	E	1.03
14. Harrison /Fifth /I-80 WB Off-Ramp	AM	26.7	C	0.54	26.5	C	0.54	34.7	C	0.71	34.3	C	0.70
	PM	63.5	E	0.93	63.0	E	0.93	> 80	F	1.11	> 80	F	1.24
	Sat	25.2	C	0.62	25.1	C	0.61	33.1	C	0.84	32.7	C	0.84
15. Avenue of the Palms/First Street	AM	18.1	B	0.85	13.3	B	0.69	18.1	B	0.85	13.3	B	0.69
	PM	40.5	D	1.03	25.3	C	0.94	40.5	D	1.03	25.3	C	0.94
	Sat	50.6	D	1.09	35.6	D	1.02	50.6	D	1.09	35.6	D	1.02

Notes:

¹ Whole intersection weighted average stopped delay expressed in seconds per vehicle calculated using methods described in the *2000 HCM*. In rare cases, if the Proposed Project adds traffic to movements with lower average delay than the average delay for the entire intersection, the Proposed Project could result in lower average delay per vehicle than the “No Project” condition.

² Intersections operating at LOS E or LOS F conditions highlighted in **bold**.

³ Intersections 9 and 14 are uncontrolled intersections without stop signs or traffic signals; therefore, a level-of-service analysis is not applicable and these intersections are not included in this table.

Source: Fehr & Peers, 2010

transit capacity of Muni line 108-Treasure Island serving the Islands (see Table VII.7). In addition, similar to the Proposed Project, impacts on the new AC Transit bus service and ferry serving the Islands, and impacts on other AC Transit, BART, Golden Gate Transit, SamTrans and other ferry lines would be less than significant. As presented in Table VII.8, the Reduced Development Alternative would add fewer transit trips to the Muni downtown San Francisco screenlines than the Proposed Project, and ridership demand would not exceed capacity.

Similar to the Proposed Project, under conditions with and without the Ramps Project, vehicle queues extending from the Bay Bridge on-ramps at Yerba Buena Island would impact Muni line 108-Treasure Island and AC Transit bus operations. With implementation of Mitigation Measure M-TR-24 (Transit and Emergency Vehicle Only Lane) described in Section IV.E, Transportation, on p. IV.E.100, the impact on Muni line 108-Treasure Island operations would be reduced to a less-than-significant level. Implementation of Mitigation Measure M-TR-24 would improve operations for AC Transit buses destined to the eastbound on-ramp. However, since this improvement would extend only to the transit and emergency vehicle-only westbound on-ramp on the west side of Yerba Buena Island, and since sufficient right-of-way is not available to extend a transit-only lane beyond the transit and emergency vehicle-only westbound on-ramp, AC Transit vehicles would continue to experience congestion between the transit and emergency vehicle-only westbound on-ramp and the eastbound on-ramp. Therefore, similar to the Proposed Project, the impact on AC Transit operations would remain significant and unavoidable.

As with the Proposed Project, transit impacts would occur from traffic congestion delay in downtown San Francisco. Overall, the transit delay conditions with the Reduced Development Alternative would affect the same lines as the Proposed Project would (27-Bryant, 30X-Marina Express, and 47-Van Ness), and would not affect operations of Golden Gate Transit or SamTrans bus lines. As noted above, implementation of Mitigation Measure M-TR-2 would reduce, but not eliminate, traffic impacts at the study intersections, and therefore the transit delay impact on the Muni lines would remain significant and unavoidable.

Bicycles

The Reduced Development Alternative bicycle trips would be accommodated within the proposed street network on the Islands and on mainland San Francisco, and similar to the Proposed Project, impacts related to bicycle accessibility would be less than significant, and no mitigation measures are required. Also, as with the Proposed Project, implementation of Mitigation Measure M-TR-24 would result in the removal of the proposed bicycle lane on a portion of Treasure Island and Hillcrest Roads to accommodate a transit-only lane (Mitigation Measure M-TR-24 would only be implemented if queues on Treasure Island Road materialize and substantially affect transit operations); however, cyclists would continue to have a Class II contra flow facility connecting Treasure Island and the Bay Bridge, via Macalla Road.

Table VII.7: Transit Ridership and Capacity Utilization – Existing plus Project and Existing plus Reduced Development Alternative

Route	Existing plus Project			Existing plus Reduced Development Alternative		
	Capacity	Rider-ship	% Utilization ¹	Capacity	Rider-ship	% Utilization ¹
<i>AM Peak Hour</i>						
AC Transit EB ²	324	107	33%	324	86	27%
AC Transit WB ²	324	67	21%	324	58	18%
Muni EB Bus Service from SF ³	252	261	104%	252	228	90%
Muni WB Bus Service to SF ³	252	384	152%	252	311	123%
Ferry EB ⁴	839	238	28%	839	201	24%
Ferry WB ⁴	839	403	48%	839	321	38%
<i>PM Peak Hour</i>						
AC Transit EB	324	96	30%	324	84	26%
AC Transit WB	324	134	41%	324	116	36%
Muni EB Bus Service from SF	252	515	204%	252	453	180%
Muni WB Bus Service to SF	252	431	171%	252	390	155%
Ferry EB	839	479	57%	839	404	48%
Ferry WB	839	343	41%	839	292	35%
<i>Saturday Peak Hour</i>						
AC Transit EB	324	79	24%	324	71	22%
AC Transit WB	324	90	28%	324	81	25%
Muni EB Bus Service from SF	189	328	174%	189	300	159%
Muni WB Bus Service to SF	189	320	169%	189	297	157%
Ferry EB	839	221	26%	839	226	27%
Ferry WB	839	252	30%	839	199	24%

Notes:

N/A = Not Applicable

¹ **Bold** indicates capacity utilization exceeds the 85 percent capacity utilization standard for Muni line 108-Treasure Island, and the 100 percent capacity utilization standard for new ferry and AC Transit service. Exceedance of the capacity utilization standard is considered a significant impact.

² New AC Transit bus service between the Islands and downtown Oakland at 10-minute peak headways.

³ Muni line 108-Treasure Island service at 15-minute headways during peak periods.

⁴ New ferry service between Treasure Island and San Francisco at 50-minute peak headways.

Source: Fehr & Peers 2010

Table VII.8: Muni Downtown Screenlines – Existing and 2030 Cumulative Conditions

	Existing plus Project			Existing plus Reduced Development Alternative			2030 Cumulative Plus Proposed Project			2030 Cumulative Plus Reduced Development Alternative		
	Project Trips	Total Riders	% Utilization	Project Trips	Total Riders	% Utilization	Project Trips	Total Riders	% Utilization	Project Trips	Total Riders	% Utilization
AM Peak Hour												
Northeast	17	1,899	50%	14	1,896	50%	17	3,003	78%	14	2,999	78%
Northwest	44	7,478	65%	35	7,469	65%	44	8,935	75%	35	8,926	74%
Southwest	89	4,337	69%	71	4,319	69%	89	7,509	74%	71	7,491	73%
Southeast	10	6,637	76%	8	6,635	76%	10	7,671	76%	8	7,669	76%
Total	160	20,351	67%	128	20,319	67%	160	27,118	75%	128	27,085	75%
PM Peak Hour												
Northeast	25	1,211	34%	22	1,208	34%	25	3,130	67%	22	3,126	67%
Northwest	65	6,686	66%	55	6,676	66%	65	8,129	70%	55	8,119	70%
Southwest	130	4,798	68%	111	4,779	68%	130	8,182	82%	111	8,163	82%
Southeast	14	7,448	77%	12	7,446	77%	14	8,823	82%	12	8,821	82%
Total	234	20,143	66%	200	20,109	66%	234	28,264	76%	200	28,229	76%

Sources: Transit Center District Plan – Transit Network Analysis, AECOM 2009, and Fehr & Peers 2010.

Pedestrians

The pedestrian network and improvements would not change materially between the Proposed Project and the Reduced Development Alternative. Generally, similar to the Proposed Project, the pedestrian environment would be improved compared to existing conditions. The Reduced Development Alternative would generate fewer pedestrian trips than the Proposed Project. The Reduced Development Alternative pedestrian trips would be accommodated within the proposed street network on the Islands and at the Ferry Building crosswalks (see Table VII.9), and similar to the Proposed Project, impacts related to pedestrian accessibility would be less than significant. No mitigation measures are required.

● **Table VII.9: Pedestrian Crosswalk Levels of Service – Existing plus Project and Existing plus Reduced Development Alternative**

Crosswalk ¹	Existing plus Project			Existing plus Reduced Development Alternative		
	Project Trips	Density ³	LOS	Project Trips	Density ³	LOS
AM Peak Hour						
Washington Street ¹	26	27.4	A	20	28.6	A
Ferry Bldg (North)	87	6.6	C	67	6.9	C
Market Street	427	6.7	C	330	7.0	C
Don Chee Way	29	17.3	A	22	18.1	A
Mission Street ¹	72	9.9	C	56	10.3	B
PM Peak Hour						
Washington Street ¹	46	13.0	A	38	13.4	A
Ferry Bldg (North)	67	7.2	C	55	7.4	C
Market Street	614	3.9	D	501	4.1	D
Don Chee Way	33	12.9	B	27	13.3	A
Mission Street ¹	61	9.9	C	50	10.1	B
Saturday Peak Hour²						
Market Street	334	4.0	D	301	4.0	D
Don Chee Way	28	6.9	C	25	6.9	C

Notes:

¹ Since the intersections of The Embarcadero with Washington Street and Mission Street each have two crosswalks, the north and south legs of each intersection were averaged.

² The Ferry Building hosts a farmers market on Saturdays.

³ Density measured in square feet per pedestrian.

Source: Fehr & Peers 2010

Loading

Similar to the Proposed Project, development associated with the Reduced Development Alternative would be subject to the freight loading space requirements to accommodate the loading demand, and would be designed to minimize impacts on autos, transit, bicyclists and pedestrians and to ensure that loading activities do not result in hazardous conditions. The Reduced Development Alternative impacts related to loading operations would be less than significant, and no mitigation measures are required.

Emergency Access

The Reduced Development Alternative impacts on emergency access would be the same as for the Proposed Project. Local police and fire facilities would provide first response to incidents on the Islands, and existing emergency routes would be maintained in their existing locations or rerouted as necessary. Similar to the Proposed Project, impacts to emergency access would be less than significant and no mitigation measures are required.

Cumulative Conditions

Although the Reduced Development Alternative would result in construction of 2,000 fewer residential units and would not include construction of 100,000 sq. ft. of office uses, given the overall magnitude of development, the project's prolonged construction period, and the lack of certainty of timing of other construction projects on the Islands, the Reduced Development Alternative would also result in significant contributions to cumulative construction-related traffic impacts.

Under 2030 Cumulative conditions, as with the Proposed Project, the Reduced Development Alternative would contribute to significant cumulative traffic impacts at the following locations:

- At the eastbound off-ramp on the west side of Yerba Buena Island;
- Under conditions without the Ramps Project, at the two westbound on-ramps; and
- Under conditions with the Ramps Project, at the ramp meter at the westbound on-ramp at the east side of Yerba Buena Island.

The Reduced Development Alternative would also result in a significant impact on queuing at the Bay Bridge toll plaza during the weekday AM and PM peak hours, and on San Francisco streets approaching the Bay Bridge during the weekday AM and PM and Saturday peak hours.

- Similar to the Proposed Project, the Reduced Development Alternative would result in less-than-significant impacts at the eastbound on-ramp and eastbound off-ramp on the east side of Yerba Buena Island, and the westbound off-ramp on the east side of Yerba Buena Island.

Table VII.6, p. VII.25, includes the comparison of intersection LOS for 2030 Cumulative plus Proposed Project and 2030 Cumulative plus Reduced Development Alternative conditions. The Reduced Development Alternative would result in significant impacts at six study intersections (compared to seven for the Proposed Project).

- - The Reduced Development Alternative would result in project-specific impacts at six study intersections that would operate at LOS D or better and deteriorate to LOS E or LOS F, or that would operate at LOS E and deteriorate to LOS F under Existing plus Project conditions (listed on p. VII.22). Because the Reduced Development Alternative would result in significant project-specific impacts at these intersections, it would also result in cumulative impacts at these six intersections (First /Market, First/Mission, First/Folsom, First/Harrison/I-80 Eastbound On-Ramp, Bryant/Fifth/I-80 Eastbound On-Ramp, Fifth/Harrison/I-80 Westbound Off-Ramp).
 - The Reduced Development Alternative would contribute considerably to critical movements at one study intersection that would operate at LOS E or LOS F under 2030 Cumulative plus Reduced Development Alternative conditions, resulting in a project impact (Second/Folsom).
- - The Reduced Development Alternative would have less-than-significant contributions at seven study intersections that would operate at LOS E or LOS F under 2030 Cumulative No Project conditions (Fremont/Howard, Fremont/Folsom, Fremont/I-80 Westbound Off-Ramp/Harrison, First/Howard, Essex/Harrison/I-80 Eastbound On-Ramp, Second/Bryant, and The Embarcadero/Harrison).
 - The Reduced Development Alternative would contribute considerably to significant cumulative impacts at two uncontrolled study intersections (Folsom/Essex and Bryant/Sterling).

As with the Proposed Project, the traffic impacts at ramps and intersections would be minimized, but not eliminated, with implementation of Mitigation Measure M-TR-2.

Under 2030 Cumulative conditions, implementation of the Reduced Development Alternative would have transit impacts similar to those of the Proposed Project. Ridership under this alternative would exceed the capacity of the Muni 108-Treasure Island bus line. The Reduced Development Alternative would add fewer transit trips to the Muni downtown San Francisco screenlines than the Proposed Project, ridership demand would not exceed capacity, and impacts on the downtown San Francisco screenlines would be less than significant (see Table VII.8). Transit impacts would occur from traffic congestion delay in downtown San Francisco and would affect the same lines as the Proposed Project would (10-Townsend, 27-Bryant, 30X-Marina Express, and 47-Van Ness). While implementation of Mitigation Measure M-TR-2 (Expanded Transit Service) would somewhat reduce delays at the downtown study intersections, the impact on transit would remain significant and unavoidable. Increased traffic congestion delay in downtown San Francisco would not affect operations of Golden Gate Transit or SamTrans bus lines.

Parking Information

Similar to the Proposed Project, development associated with the Reduced Development Alternative would be subject to parking space maximums. The Reduced Development Alternative would include 8,953 parking spaces, including 6,000 spaces for residential uses, and

2,953 spaces for non-residential uses. The Reduced Development Alternative would result in a demand for 7,624 spaces for residential uses and 2,056 spaces for non-residential uses. Overall, during the peak hour of parking demand for all of Treasure Island, the Reduced Development Alternative would result in a deficit of 651 parking spaces, including a deficit of 1,565 residential spaces and a surplus of 914 non-residential spaces. Yerba Buena Island would experience a shortfall of 76 spaces during its peak hour of parking demand, comprised of 59 residential spaces and 17 non-residential spaces.

As with the Proposed Project, implementation of the parking supply maximums would result in secondary physical impacts caused by increased traffic congestion and a mode shift to transit that would exacerbate the exceedance of capacity utilization standards on Muni line 108-Treasure Island. As with the Proposed Project, the transit capacity utilization would be minimized, but not eliminated, with implementation of Mitigation Measure M-TR-2.

Noise

Under the Reduced Development Alternative, similar construction activities would occur as under the Proposed Project. Deep dynamic compaction and vibro-compaction would occur to the same degree as the Proposed Project. Pile driving for the ferry quay and breakwaters would also be the same, but there may be reduced duration of pile driving for construction of multi-story residential buildings. Noise impacts from non-impact equipment and truck trips would be similar to those of the Proposed Project.

This alternative would develop the same land uses except that no office space and fewer residential units would be developed. Operational noise impacts from the intermodal Transit Hub with its associated ferry trips and East Bay bus service would be the same as for the Proposed Project.

Because the Reduced Development Alternative would include fewer residential units, local roadway traffic volumes would be decreased slightly in the future compared to the Proposed Project. Table VII.10 presents the modeled roadway noise levels that would occur with development of the Reduced Development Alternative, with and without implementation of Mitigation Measure M-TR-2 (Expanded Transit Service), as described in Section IV. E, Transportation, p. IV.E.74.

Table VII.10: Modeled Reduced Development Alternative Traffic L_{dn} Noise Levels

Roadway Segment ^a	Existing	Existing plus Reduced Development Alternative	dBA Difference	Significant Increase	Existing plus Reduced Development Alternative with Mitigated Transit ^b	dBA Difference	Significant Increase
Weekday L_{dn} Noise Levels							
Avenue of the Palms, north of 1st Street	61.9	66.9	5.0	Yes	66.6	4.7	Yes
Avenue of the Palms, south of 1st Street	62.2	67.9	5.7	Yes	67.8	5.6	Yes
1st Street, east of Avenue of the Palms	56.8	65.5	8.7	Yes	66.0	9.2	Yes
Saturday L_{dn} Noise Levels							
Avenue of the Palms, north of 1st Street	69.3	68.9	-0.4	No	68.7	-0.6	No
Avenue of the Palms, south of 1st Street	60.8	70.0	9.2	Yes	69.7	8.9	Yes
1st Street, east of Avenue of the Palms	56.7	65.9	9.2	Yes	66.0	9.3	Yes

Notes:

^a Road center to receptor distance is assumed to be 50 feet for values shown in this table. Noise levels were determined using FHWA Traffic Noise Model Version 2.5 Look-Up Tables. The average speed on these segments is assumed to be 25 miles per hour. For all other assumptions, refer to Appendix D. The incremental increase is considered significant if the increase is more than or equal to 5 dBA, or if it is equal to or greater than 3 dBA with an ambient noise environment between 60 and 65 dBA, or if the noise increase is equal to or greater than 1.5 dBA with an ambient noise environment greater than 65 dBA.

^b This condition assumes implementation of Mitigation Measure M-TR-2 (Expanded Transit Service) as discussed in Section IV.E, Transportation, p. IV.E.74.

Source: ESA 2010

The noise modeling results indicate that while noise levels would be reduced at most roadways, all significant roadway noise impacts identified for the Proposed Project would also occur with the Reduced Development Alternative.

Cumulative roadway noise levels would also be reduced under this alternative. Table VII.11 presents the modeled cumulative roadway noise levels that would occur with development of the Reduced Development Alternative. The noise modeling results indicate that while cumulative noise levels would be reduced at most roadways, all significant cumulative roadway noise impacts identified for the Proposed Project would also occur with this alternative.

Table VII.11: Modeled Cumulative Reduced Development Alternative Traffic L_{dn} Noise Levels

Roadway Segment	Existing	2030 plus Reduced Development Alternative	dBA Difference	Significant Increase	2030 plus Red. Development plus Expanded Transit	dBA Difference	Significant Increase
Weekday L_{dn} Noise Levels							
Avenue of the Palms, north of 1st Street	61.9	66.5	4.6	Yes	66.6	4.7	Yes
Avenue of the Palms, south of 1st Street	62.2	66.9	4.7	Yes	67.6	5.4	Yes
1st Street, east of Avenue of the Palms	56.8	65.5	8.7	Yes	66.0	9.2	Yes
Saturday L_{dn} Noise Levels							
Avenue of the Palms, north of 1st Street	69.3	68.9	-0.4	No	68.7	-0.6	No
Avenue of the Palms, south of 1st Street	60.8	70.0	9.2	Yes	69.7	8.9	Yes
1st Street, east of Avenue of the Palms	56.7	65.9	9.2	Yes	66.0	9.3	Yes

Note:

Road center to receptor distance is assumed to be 50 feet for values shown in this table. Noise levels were determined using FHWA Traffic Noise Model Version 2.5 Look-Up Tables. The average speed on these segments is assumed to be 25 miles per hour. For all other assumptions, refer to Appendix D. The incremental increase is considered significant if the increase is more than or equal to 5 dBA, or if it is equal to or greater than 3 dBA with an ambient noise environment between 60 and 65 dBA, or if the noise increase is equal to or greater than 1.5 dBA with an ambient noise environment greater than 65 dBA.

Source: ESA 2010

Air Quality

Under the Reduced Development Alternative, similar construction activities would occur as under the Proposed Project. The same type of diesel powered construction equipment and truck trips would be generated, but materials delivery truck trips would be reduced, as the number of residential units constructed would be reduced. The duration of later phases of construction would also be reduced compared to the Proposed Project. Fugitive construction dust would also be generated from excavation and movement of trucks and equipment both on-road and off-road. As with the Proposed Project, fugitive dust emissions from construction activities would be less than significant with incorporation of BAAQMD-identified mitigation measures in Mitigation Measure M-AQ-1, p. IV.G.26.

Daily criteria pollutant emission estimates from construction would be the same as those calculated for the Proposed Project and would remain significant and unavoidable under this alternative with implementation of Mitigation Measure M-AQ-2, although the duration of this significant impact may be reduced with construction of fewer residential units. Health risks from

construction-related diesel particulate matter (“DPM”) and PM2.5 would also be the same as the Proposed Project and would remain significant and unavoidable even with implementation of Mitigation Measure M-AQ-3.

The Reduced Development Alternative would develop the same land uses with the exception of no office space and fewer residential units. Operational emissions from vehicle trip generation would be slightly reduced, as the Proposed Project would generate 30,330 additional vehicle trips per day and the Reduced Development Alternative would generate about 26,965 additional vehicle trips per day. Operational air quality emissions from the Transit Hub with its associated ferry trips and new East Bay bus service would be similar to the Proposed Project.

Because of the reduced amount of development in this alternative, vehicle trip generation and its associated regional air pollutant emissions would be decreased in the future compared to the Proposed Project. Table VII.12 presents the modeled air emissions that would occur with the Proposed Project and with the Reduced Development Alternative. Table VII.13 presents the modeled air emissions that would occur with the Expanded Transit Service in Mitigation Measure M-TR-2 applied to the Proposed Project, and compares them to those from the Reduced Development Alternative with the same mitigation measure (M-TR-2, Expanded Transit Service).

The Expanded Transit Service would include the same Transportation Design Features as the Base Transit System included in both the Proposed Project and the Reduced Development Alternative, with the following changes or additions:

- New ferry service to San Francisco every 15 minutes provided by a fleet of three ferries;
- Modification of the existing Muni line 108-Treasure Island bus service to increase peak hour frequency from every 15 minutes to every 7 minutes in the AM peak hour and every 5 minutes in the PM peak hour. Additionally, existing buses would be replaced with larger capacity buses; and
- New SF Muni bus service to the San Francisco Civic Center area.

As can be seen from Table VII.12, the Reduced Development Alternative would reduce ROG emissions by 22 percent, NOx emissions by 4 percent, PM10 emissions by 12 percent and PM2.5 emissions by 10 percent compared to the Proposed Project.

The Reduced Development Alternative with Mitigation Measure M-TR-2 (Expanded Transit Service) would reduce ROG emissions by 20 percent, NOx emissions by 2 percent, PM10 emissions by 12 percent and PM2.5 emissions by 10 percent compared to the Proposed Project with Expanded Transit Service. Reduced motor vehicle trip generation under this Alternative would also result in lower localized CO concentrations. CO concentrations under all scenarios

Table VII.12: Estimated Daily Emissions - Proposed Project and Reduced Development Alternative

Emission Source	Estimated Daily Emissions (pounds per day)					
	ROG	NO _x	CO ^a	SO ₂	PM10	PM2.5
Proposed Project (2030)						
On Site Natural Gas	2	26	22	<1	<1	<1
Landscape Equipment	1	<1	18	<1	<1	<1
Consumer Products	392	NA	NA	NA	NA	NA
Architectural Coating	66	NA	NA	NA	NA	NA
Motor Vehicles	130	97	1,047	3	517	97
Buses	1	29	4	<1	3	1
Ferries	21	290	136	<1	8	7
Shuttle Buses	2	15	9	<1	<1	<1
Total Proposed Project (2030)	615	457	1,236	3	528	105
<i>1999 BAAQMD Threshold</i>	<i>80</i>	<i>80</i>	<i>550</i>	<i>NA</i>	<i>80</i>	<i>NA</i>
Significant?	Yes	Yes	Yes	No	Yes	NA
<i>2010 BAAQMD Threshold</i>	<i>54</i>	<i>54</i>	<i>NA</i>	<i>NA</i>	<i>82</i>	<i>54</i>
Significant?	Yes	Yes	NA	NA	Yes	Yes
Reduced Development Alternative (2030)						
On Site Natural Gas	2	20	17	<1	<1	<1
Landscape Equipment	1	<1	17	<1	<1	<1
Consumer Products	293	NA	NA	NA	NA	NA
Architectural Coating	52	NA	NA	NA	NA	NA
Motor Vehicles	110	85	947	3	455	86
Buses	1	29	4	<1	3	1
Ferries	21	290	136	<1	8	7
Shuttle Buses	2	15	9	<1	<1	<1
Total Reduced Development Alternative (2030)	482	439	1,130	3	466	94
<i>1999 BAAQMD Threshold</i>	<i>80</i>	<i>80</i>	<i>550</i>	<i>NA</i>	<i>80</i>	<i>NA</i>
Significant?	Yes	Yes	Yes	No	Yes	No
<i>2010 BAAQMD Threshold</i>	<i>54</i>	<i>54</i>	<i>NA</i>	<i>NA</i>	<i>82</i>	<i>54</i>
Significant?	Yes	Yes	No	No	Yes	Yes

Note:

^a The 1999 BAAQMD CEQA Guidelines state that exceeding the 550 pound-per-day CO threshold does not necessarily reflect a significant CO impact, but it does trigger a modeling assessment of localized CO concentrations to determine significance. This modeling analysis is addressed for the Proposed Project in Section IV.G, Air Quality, Impact AQ-6, and shows that the Proposed Project would not exceed State or Federal CO standards. The Reduced Development Alternative would result in less CO emissions and therefore would also not exceed CO standards.

Source: ESA 2010

Table VII.13: Estimated Daily Emissions - Proposed Project and Reduced Development Alternative with Expanded Transit Service Mitigation Measure

Emission Source	Estimated Daily Emissions (pounds per day)					
	ROG	NO _x	CO ^a	SO ₂	PM10	PM2.5
Proposed Project w/ Expanded Transit Service (2030)						
On Site Natural Gas	2	26	22	<1	<1	<1
Landscape Equipment	1	<1	18	<1	<1	<1
Consumer Products	392	NA	NA	NA	NA	NA
Architectural Coating	66	NA	NA	NA	NA	NA
Motor Vehicles	115	81	879	2	434	82
Buses	2	57	8	<1	5	3
Ferries	62	871	409	<1	23	22
Shuttle Buses	2	15	9	<1	<1	<1
Total, Proposed Project w/ Expanded Transit Service (2030)	642	1,050	1,345	2	462	107
<i>1999 BAAQMD Threshold</i>	80	80	550	NA	80	NA
Significant?	Yes	Yes	Yes	No	Yes	No
<i>2010 BAAQMD Threshold</i>	54	54	NA	NA	82	54
Significant?	Yes	Yes	NA	NA	Yes	Yes
Reduced Development Alternative w/ Expanded Transit Service (2030)						
On Site Natural Gas	2	20	17	<1	<1	<1
Landscape Equipment	1	<1	17	<1	<1	<1
Consumer Products	293	NA	NA	NA	NA	NA
Architectural Coating	52	NA	NA	NA	NA	NA
Motor Vehicles	97	71	789	2	379	71
Buses	2	57	8	<1	5	3
Ferries	62	871	409	<1	23	22
Shuttle Buses	2	15	9	<1	<1	<1
Total Reduced Development Alt. w/ Expanded Transit Service (2030)	511	1,034	1,249	2	407	96
<i>1999 BAAQMD Threshold</i>	80	80	550	NA	80	NA
Significant?	Yes	Yes	Yes	No	Yes	No
<i>2010 BAAQMD Threshold</i>	54	54	NA	NA	82	54
Significant?	Yes	Yes	No	No	Yes	Yes

Note:

^a The 1999 BAAQMD CEQA Guidelines state that exceeding the 550 pound-per-day CO threshold does not necessarily reflect a significant CO impact, but it does trigger a modeling assessment of localized CO concentrations to determine significance. This modeling analysis is addressed for the Proposed Project in Section IV.G, Air Quality, Impact AQ-6, and shows that the Proposed Project would not exceed State or Federal CO standards. The Reduced Development Alternative would result in less CO emissions and therefore would also not exceed CO standards.

Source: ESA 2010

would be less than those with the Proposed Project, which were shown in Section IV.G, Air Quality, Impact AQ-6, to be well below State standards; therefore, the CO concentrations under the Reduced Development Alternative would represent a less-than-significant impact.

Health risks from exposure to project-generated DPM were found to be significant under the Proposed Project unless mitigated by diesel particulate filters or other technology with similar effectiveness. These emissions would be generated by both ferries and diesel buses. The Reduced Development Alternative would result in the same numbers of ferry and bus trips as the Proposed Project. Consequently, health risk impacts related to DPM exposure would be the same under this Alternative as under the Proposed Project. Health risk impacts related to DPM exposure would also be the same under the Reduced Development Alternative with Mitigation Measure M-TR-2 (Expanded Transit Service) as under the Proposed Project with the Expanded Transit Service. Health risk impacts from exposure to DPM from existing mobile sources on the Bay Bridge would also be the same under the Proposed Project and the Reduced Development Alternative.

Health risks from exposure⁹ to project-generated fine particulate matter (PM2.5) were found to be less than significant under the Proposed Project and would be further reduced by diesel particulate filters identified as mitigation for DPM impacts. These emissions would be generated by both ferries and diesel buses, as well as by motor vehicles. The Reduced Development Alternative would result in the same numbers of ferry and bus trips as the Proposed Project and would reduce motor vehicle trips (by 11 percent). Consequently, health risk impacts related to project-generated PM2.5 exposure would be less under the Reduced Development Alternative than under the Proposed Project and would also be less than significant. Health risk impacts to new residents on Yerba Buena Island from exposure to PM2.5 from existing mobile sources on the Bay Bridge would also be the same under the Proposed Project and the Reduced Development Alternative, although the number of new receptors exposed to high levels of PM2.5 might be less if fewer residential units were constructed on Yerba Buena Island with this alternative.

There would be no differences between the Reduced Development Alternative and the Proposed Project with regard to existing or proposed odor sources, because the types of uses would be the same for both, and the new or upgraded wastewater treatment plant would be in the same location, would use the same processes and chemicals, and would be essentially the same size. Odor impacts, like those under the Proposed Project, would be less than significant under the Reduced Development Alternative.

There would be no differences between the Reduced Development Alternative and the Proposed Project with regard to consistency with the Bay Area Clean Air Plan (“CAP”). CAP consistency

⁹ This refers to localized exposures to concentrations of PM2.5, not mass daily emissions of PM2.5, which is a regional impact.

impacts would be significant under the Reduced Development Alternative, like those identified for the Proposed Project as the rate of increase in vehicle miles traveled under this alternative (0.54 percent) would be greater than the rate of increase in population (0.42 percent). Unlike the Proposed Project with Expanded Transit Service, the Reduced Development Alternative with Expanded Transit Service would have a significant CAP consistency impact, as the rate of increase in vehicle miles traveled under this alternative (0.45 percent) would be greater than the rate of increase in population (0.42 percent).

Cumulative air quality impacts, like those under the Proposed Project, would be significant and unavoidable under the Reduced Development Alternative.

Greenhouse Gases

Under the Reduced Development Alternative, construction activities would be similar to those with the Proposed Project. The same types of diesel-powered construction equipment and truck trips would be generated, but the number of materials delivery truck trips would be somewhat reduced and construction duration could be reduced, as there would be 25 percent fewer residential units constructed. Therefore, construction-related GHG emissions over the entire duration of construction would be less under the Reduced Development Alternative than under the Proposed Project, even if emissions on a peak daily basis would be similar.

The Reduced Development Alternative would develop the same land uses with the exception of no new office space and fewer residential units. Operational GHG emissions from increased vehicle trip generation would be slightly reduced from those of the Proposed Project, as the Proposed Project would generate 30,330 additional vehicle trips per day and the Reduced Development Alternative would generate about 26,965 additional vehicle trips per day. Operational GHG emissions from the Transit Hub with its associated ferry trips and East Bay bus service would be similar to the Proposed Project, because the same numbers of ferry and bus trips are assumed with this alternative.

Under the Reduced Development Alternative, vehicle trip generation and its associated GHG emissions would be less in the future compared to the Proposed Project. Table VII.14 presents the modeled air emissions that would occur with the Proposed Project and with the Reduced Development Alternative. Table VII.15 presents the modeled GHG emissions that would occur under the Proposed Project with implementation of Mitigation Measure M-TR-2 (Expanded Transit Service) and compares them to the Reduced Development Alternative with an Expanded Transit Service.

The Expanded Transit Service mitigation measure would include the same Transportation Design Features as in the Base Transit Scenario included in both the Proposed Project and the Reduced Development Alternative, with the following changes or additions:

Table VII.14: Emissions of GHG - Proposed Project and Reduced Development Alternative

Emission Source/Sink	Emissions (metric tons CO ₂ e per year)			
	CO ₂	CH ₄	N ₂ O	Total CO ₂ e
Proposed Project				
Motor vehicle trips	45,431	139	2,729	48,299
Buses	971	--	1	972
Ferries	3,215	5	26	3,246
Shuttle Buses	247	5	6	258
Natural gas	5,188	10	3	5,201
Grid Electricity	--	--	--	1,030
Solid Waste generation	--	--	--	4,544
Water Conveyance	452	--	2	455
Wastewater Treatment & Conveyance	On-island WWTP Treatment & Conveyance Energy included in Grid Electricity Above (inclusive of stormwater and recycled water)			
Area Source (landscape maintenance)	3	--	--	3
Total Proposed Project Operational Greenhouse Gas Emissions				64,008
Reduced Development Alternative				
Motor vehicle trips	39,966	122	2,403	42,491
Buses	971	--	1	972
Ferries	3,215	5	26	3,246
Shuttle Buses	247	5	6	258
Natural gas	3,891	8	3	3,901
Grid Electricity	--	--	--	745
Solid Waste generation	--	--	--	3,476
Water Conveyance	339	--	2	341
Wastewater Treatment & Conveyance	On-island WWTP Treatment & Conveyance Energy included in Grid Electricity Above (inclusive of stormwater and recycled water)			
Area Source (landscape maintenance)	3	--	--	3
Total Reduced Development Alternative Operational Greenhouse Gas Emissions				55,433

Source: ESA 2010

- New ferry service to San Francisco every 15 minutes provided by a fleet of three ferries;
- Modification of the existing Muni line 108-Treasure Island bus service to increase peak hour frequency from every 15 minutes to every 7 minutes in the AM peak hour and every 5 minutes in the PM peak hour. Additionally, existing buses would be replaced with larger capacity buses; and
- New SF Muni bus service to the San Francisco Civic Center area.

As can be seen from Table VII.14 the Reduced Development Alternative would reduce operational GHG emissions by 13 percent compared to the Proposed Project. Table VII.15 shows that the Reduced Development Alternative with the Expanded Transit Service in Mitigation Measure M-TR-2 would reduce operational GHG emissions by 12 percent compared to the Proposed Project with the Expanded Transit Service.

Table VII.15: Emissions of GHGs - Proposed Project and Reduced Development Alternative with Expanded Transit Service Mitigation Measure

Emission Source/Sink	Emissions (metric tons CO ₂ e per year)			
	CO ₂	CH ₄	N ₂ O	Total CO ₂ e
Proposed Project with Expanded Transit Service				
Motor vehicle trips	38,147	116	2,292	40,555
Buses	1,905	--	1	1,906
Ferries	9,645	15	77	9,737
Shuttle Buses	247	5	6	258
Natural gas	5,188	10	3	5,201
Grid Electricity	--	--	--	1,030
Solid Waste generation	--	--	--	4,544
Water Conveyance	452	--	2	455
Wastewater Treatment & Conveyance	On-Island WWTP Treatment & Conveyance Energy included in Grid Electricity Above (inclusive of stormwater and recycled water)			
Area Source (landscape maintenance)	3	--	--	3
Total Proposed Project with Expanded Transit Service Operational Greenhouse Gas Emissions				63,689
Reduced Development Alternative with Expanded Transit Service				
Motor vehicle trips	33,264	102	2,000	35,365
Buses	1,905	--	1	1,906
Ferries	9,645	15	77	9,737
Shuttle Buses	247	5	6	258
Natural gas	3,891	8	3	3,901
Grid Electricity	--	--	--	745
Solid Waste generation	--	--	--	3,476
Water Conveyance	339	--	2	341
Wastewater Treatment & Conveyance	On-Island WWTP Treatment & Conveyance Energy included in Grid Electricity Above (inclusive of stormwater and recycled water)			
Area Source (landscape maintenance)				3
Total Reduced Development Alternative with Expanded Transit Service Operational Greenhouse Gas Emissions				55,732

Source: ESA 2010

Wind and Shadow

The Reduced Development Alternative would have the same street grid and a similar organization of low- and mid-rise buildings as the Proposed Project, but it could potentially have fewer high-rise towers than the 19 high-rise towers in the Proposed Project. As a direct result of having the same street grid and a similar organization of low- and mid-rise buildings, the Reduced Development Alternative would cause overall shadowing of adjacent streets, sidewalks,

and neighborhood open spaces that would be generally the same as the shadowing from the Proposed Project. However, with fewer towers, there would be less transitory shadow reaching into the larger open spaces from the towers, primarily during the early mornings and late afternoons during the spring, autumn, and winter months.

As a result of having the same street grid and a similar organization of low- and mid-rise buildings as the Proposed Project, the Reduced Development Alternative would result in overall reductions in wind speeds in the interior of the development, similar to the Proposed Project, while wind conditions at the outer edges of the built areas would remain very windy. It is anticipated that the reductions in the wind speeds that would be exceeded 10 percent of the time would be similar to those of the Proposed Project. Furthermore, it is anticipated that the substantial reductions in the number and duration of the existing wind hazards that would occur with the Proposed Project would also occur with the Reduced Development Alternative. As with the Proposed Project, under the Reduced Development Alternative, the occurrence of wind hazards would be higher along the development's outer edges and the relative frequency of wind hazards generally would diminish in its interior, except for the particular wind effects of open exposures to winds from the Bay, the pedestrian-level wind effects of tall buildings, or the effects of strong incident winds channeling between the building masses and along the streets. Similar mitigation (Mitigation Measures M-WS-3 and M-WS-4) would be available to address wind impacts. As discussed under Impacts in Section IV.I.2, Wind, it may not be possible to mitigate all wind hazards, existing or new, to less-than-significant levels. Thus, the wind impacts of the Reduced Development Alternative, like those of the Proposed Project, would be considered to be significant and unavoidable.

Recreation

As with the Proposed Project, the Reduced Development Alternative would provide approximately 300 acres of parks and open space on Treasure Island and Yerba Buena Island, for use by local and Bay Area residents, and a Habitat Management Plan would be implemented for much of the undeveloped open space portions of Yerba Buena Island.

Like the Proposed Project, the Reduced Development Alternative would provide an integrated system of neighborhood- and region-serving parks and playgrounds, open spaces such as public plazas, courtyards, and cultural areas, athletic fields, and greenways. However, since this alternative would result in 4,550 fewer residents than the Proposed Project, it would provide more parks and open space per resident than the Proposed Project would - about 23 acres of parks and open space per 1,000 residents, compared to 17 acres with the Proposed Project. This ratio is substantially higher than the current Citywide ratio of about 8 acres of parks and open space per 1,000 residents. The Reduced Development Alternative would generate approximately 2,560 jobs, which could result in a maximum daytime population of up to approximately 16,540

(including the [increased] residential population of about 13,980), and assuming that no residents were employed off site, which is unlikely. Counting the entire daytime population as a part of the population served by the parks and open space in the Development Plan Area, the parks and open space-to-population ratio would be about 20 acres per 1,000 employees and residents. As with the Proposed Project, soccer pitches, baseball diamonds and other athletic fields (as part of the 25- to 40-acre Sports Park) would be provided under this alternative which would help the City meet the existing unmet demand for 35 additional soccer fields and 30 additional baseball/softball fields, as discussed in Section IV.J, Recreation.

Public health concerns about the use of recycled rubber tires as a base material for synthetic turf fields as well as the use of synthetic grass blades discussed for the Proposed Project (see pp. IV.J.21-IV.J.25) would be applicable under the Reduced Development Alternative, and the impact would be less than significant. As with the Proposed Project, these potential concerns could be minimized with implementation of Improvement Measure I-RE-1.

The Reduced Development Alternative would not cause substantial physical degradation of other City or regional recreation facilities or resources; nor would it result in construction of recreation facilities that would adversely impact the environment. Therefore, as with the Proposed Project, the Reduced Development Alternative would have less-than-significant impacts on recreation and no mitigation measures are required.

Utilities and Service Systems

Under the Reduced Development Alternative, new or upgraded wastewater, recycled water, stormwater, water supply, electricity, natural gas, and telecommunications infrastructure would be installed, similar to those planned for the Proposed Project (see Section IV.K, Utilities and Service Systems). Construction of these infrastructure improvements could result in impacts on air quality, noise, water quality, transportation, hazardous materials, and biological resources. These impacts are discussed under appropriate topic headings for this alternative. Because some of the infrastructure may be slightly less than that for the Proposed Project, construction impacts in some cases could be correspondingly smaller in scale or duration; however, the reduced scale would not be expected to substantially reduce any construction-related impacts identified for the Proposed Project, as the overall development footprint and layout of the infrastructure network would largely be the same.

The Reduced Development Alternative would include a new or upgraded wastewater collection and treatment system, a new stormwater collection and treatment system, and a recycled water system, as would the Proposed Project. Various tanks, pipes, or other equipment for the wastewater collection and treatment system could be slightly smaller, because less wastewater would be generated, but the impact conclusions would remain less than significant, as those identified for the Proposed Project for all three of these systems.

Demand for potable water would be less than that described for the Proposed Project. Various storage tanks, pipes, or other equipment would be slightly smaller because of lower demand. The impact analysis regarding water supply would not be qualitatively different from that for the Proposed Project, and sufficient water would be available through the SFPUC's Regional Water System to serve the development under this alternative. As with the Proposed Project, no significant impacts on water supply would result.

Solid waste generation would be less than that under the Proposed Project. The conclusions of the impact analysis would not change for the Reduced Development Alternative.

New electricity, natural gas, and telecommunications infrastructure would be installed. Particular distribution lines and equipment might be somewhat smaller, due to lower demand. The impact analysis and conclusions would be similar to those for the Proposed Project.

In summary, as with the Proposed Project, there would be no significant environmental impacts associated with operating the utilities and service systems under the Reduced Development Alternative.

Public Services

Compared to the Proposed Project, the Reduced Development Alternative would require similar police and fire staffing levels at the new combined police and fire station, because staffing levels are based in part on the number of residents, and in part on the expected number of emergency calls. Response times for police and fire protection services would also be similar. Under this alternative, the new combined police/fire station would be constructed on Treasure Island in the same central location, and the recycled water firefighting system would be installed. The Reduced Development Alternative would have less-than-significant impacts on police and fire and emergency services, similar to those described for the Proposed Project in Section IV.L, Public Services.

In this alternative, the Treasure Island School would be renovated or rebuilt, and existing educational programs would need to be relocated, as they would for the Proposed Project. Since there would be fewer students located on the Islands under the Reduced Development Alternative, fewer high-school students would be added to the expected future shortfall of classroom space in San Francisco, and more off-Islands elementary and middle school students would be accommodated at the Treasure Island School. As with the Proposed Project, impacts on schools would be less than significant with this alternative.

As with the Proposed Project, libraries and hospitals would have sufficient capacity to serve the Islands' future residents.

Overall, the Reduced Development Alternative would have less-than-significant impacts on public services, similar to those identified for the Proposed Project in Section IV.L, Public Services.

Biological Resources

Compared with the Proposed Project, the Reduced Development Alternative would have many of the same or nearly the same direct terrestrial or offshore biological impacts analyzed for the Proposed Project regarding land conversion, geotechnical stabilization, and infrastructure development, especially the ferry quay. The reduced footprint and lower number of residents would proportionately lessen the human-induced wildlife disturbance such as foot and vehicle traffic, off-leash dogs and feral cats. The draft *Habitat Management Plan* for Yerba Buena Island would be implemented as part of the Reduced Development Alternative. This would be expected to improve habitat structure, biodiversity and stability on Yerba Buena Island. With the Proposed Project, biological impacts of the Reduced Development Alternative would be less than significant with implementation of the mitigation measures identified for the Proposed Project in Section IV.M, Biological Resources. As with the Proposed Project, however, the impact of ferry service on rafting waterbirds would remain significant and unavoidable if the Water Emergency Transit Authority (“WETA”), the responsible agency, does not implement Mitigation Measure M-BI-4b: Changes in Ferry Service to Protect Rafting Waterbirds.

Geology and Soils

The Reduced Development Alternative would have impacts similar to those identified for the Proposed Project. As with the Proposed Project, the Reduced Development Alternative would implement geotechnical stabilization measures that would reduce seismic hazards. The Reduced Development Alternative would include Mitigation Measure M-GE-5 which would require slope stability improvements on Yerba Buena Island. This alternative would also incorporate emergency access procedures during the event of damage to the ferry quay or viaduct structures on Yerba Buena Island. Therefore, the Reduced Development Alternative would have similar, less-than-significant impacts on geology and soils in comparison to the Proposed Project.

Hydrology and Water Quality

Implementation of the Reduced Development Alternative would result in reduced construction activities compared to the Proposed Project. The Reduced Development Alternative would have the same amount of open space as the Proposed Project, and therefore is anticipated to have approximately the same area of new impervious surfaces as the Proposed Project. Facilities, including proposed wastewater treatment plant upgrades, water and utility infrastructure, a Ferry Terminal, and other facilities constructed under this alternative would also be similar to the Proposed Project, although these would likely be sized somewhat smaller or lesser in extent,

- according to reduced load requirements of more limited development. The Reduced Development Alternative would include implementation of stormwater Best Management Practices (“BMPs”) and adherence to water discharge and other permit conditions during construction, as described for the Proposed Project in Impacts HY-1 and HY-2 on pp. IV.O.35-IV.O.38, and an adaptive management strategy to protect Treasure Island from potential flooding due to sea level rise as described for the Proposed Project on pp. IV.O.32-IV.O.35. Therefore, implementation of this alternative would result in similar hydrology and water quality impacts, although slightly reduced in intensity, as compared to the Proposed Project. Therefore, as with the Proposed Project, construction-related hydrology and water quality impacts of this alternative would be less than significant with implementation of Mitigation Measure M-HZ-1, which requires a Site and Groundwater Management Plan (“SGMP”) as included in the Proposed Project.

Hazards and Hazardous Materials

The Reduced Development Alternative would have potential impacts similar to those of the Proposed Project, although the overall use, storage and transport of hazardous materials would be reduced. The Navy would continue to be responsible for completing its remediation responsibilities under the requirements of CERCLA and the Petroleum Program. The additional remediation required to support the proposed land uses by the project sponsors would be the same. As with the Proposed Project, implementation of Mitigation Measures M-HZ-1 and M-HZ-8 would reduce potential exposure to hazardous materials emissions during construction, and implementation of Mitigation Measure M-HZ-13 would reduce potential exposure to hazardous materials emissions at the existing Treasure Island School to less-than-significant levels. Therefore, as with the Proposed Project, impacts of the Reduced Development Alternative on hazards and hazardous materials would be less than significant with implementation of the proposed mitigation measures included in the Proposed Project.

Mineral and Energy Resources

The Reduced Development Alternative would include the same types of energy conservation measures as the Proposed Project would. In addition, new renewable energy sources, such as solar photovoltaic panels, would be developed to offset energy demand. This alternative would generate less demand for electricity, natural gas, heating, and cooling on the Islands than under the Proposed Project because fewer people would live and work there. Like the Proposed Project, the Reduced Development Alternative would not result in significant environmental impacts associated with mineral and energy resources.

Agricultural Resources and Forest Land

The Reduced Development Alternative would have agricultural effects similar to those described for the Proposed Project in Section IV.R, Agricultural Resources and Forest Land. Informal harvesting of olives for olive oil would be halted. The proposed 20-acre Urban Agricultural Park would be created, which would provide for composting green waste generated on the Islands. As under the Proposed Project, the Urban Agricultural Park would provide new opportunities for agricultural-related training and employment, local business development, and educational programs.

Similarly, natural habitats on Yerba Buena Island would be maintained under a Habitat Management Plan that would be implemented as part of the Reduced Development Alternative, to protect and enhance existing native habitat. Therefore, as with the Proposed Project, impacts to agricultural resources and forest land would be less than significant under the Reduced Development Alternative.

C. NO FERRY SERVICE ALTERNATIVE

DESCRIPTION

Unlike the Proposed Project, Alternative C, No Ferry Service, would not include the proposed Ferry Terminal and ferry service would not be provided (see Figure VII.2: No Ferry Service Alternative). If no ferry service is provided, residents, visitors, and employees would travel to and from the Island by private vehicle or bus transit. This alternative assumes that funding would be available to provide the level of bus service to San Francisco and the East Bay that is described in transportation Mitigation Measure M-TR-2, Expanded Transit Service (see Section IV.E, Transportation, pp. IV.E.74-IV.E.75). Thus, the level of bus service to the San Francisco mainland in this alternative would be greater than that for the Proposed Project. The No Ferry Service Alternative would provide fewer residential units and less neighborhood-serving retail space than in the Proposed Project, unless it were subsidized; these reductions were estimated based on the estimated amount of transit service that would be available, and assuming that Muni service goals would be met (buses operating at an average of 85 percent of seated and standing capacity).

Based on these factors, the number of residential units in the No Ferry Service Alternative would be reduced to amounts that would generate peak commute travel that could be accommodated by bus transit alone, without increasing peak-hour automobile travel. Therefore, this alternative would include up to 5,100 residential units, about 2,900 fewer units than with the Proposed Project. Residential parking would be reduced by the same amount, resulting in a total of about 8,255 parking spaces that would include the same number of on-street parking spaces as in the Proposed Project. The No Ferry Service Alternative was considered in response to comments on



— Wireframe heights reflect heights shown
in Figure II.6a: Treasure Island Maximum Height Limit Plan

■ Existing buildings to be retained

□ Proposed buildings

Towers can move within their respective wireframe boxes.

Towers cannot exceed the heights indicated by their respective wireframe boxes.

SOURCE: Perkins+Will

the NOP and to evaluate if and to what extent development of fewer residential units on Treasure Island would avoid or substantially lessen traffic and traffic-related air quality and noise impacts, as well as air quality impacts related to ferry operations. This alternative was also considered to evaluate to what extent it would avoid or lessen impacts on scenic views, noise, and historic resources.

Table VII.16 summarizes the major differences in land uses.

● **Table VII.16: Key Land Use Differences - Proposed Project and No Ferry Service Alternative**

Land Use	Proposed Project	No Ferry Service Alternative
Residential	8,000 units	5,100 units
Parking	10,675 spaces	8,255 spaces
Parks and Open Space	300 acres	306 acres

Source: Turnstone Consulting April, 2010

Most other land uses would be the same as with the Proposed Project: 100,000 sq. ft. of office space; 500 hotel rooms, including 50 on Yerba Buena Island; adaptive reuse of about 311,000 sq. ft. of Buildings 1, 2, and 3 with retail, light industrial/food production, and entertainment uses; landside facilities to support the expanded marina at Clipper Cove; new Sailing Center landside support and waterside launch facilities; and reuse or reconstruction of the existing Treasure Island elementary school at its current location.

As discussed below, the development footprint would be slightly reduced compared to the Proposed Project, to accommodate preservation of the *U.S.S. Buttercup* training facility.

The blocks not developed as a result of this preservation (Blocks E5 and E7) would be added to the overall open space program, resulting in about 306 acres of open space for this alternative, 6 more acres than provided in the Proposed Project. Up to 40 acres of athletic fields in a Sports Park, and a cultural park with a museum would be included in the open space, as with the Proposed Project. A new joint police/fire station would be provided on Treasure Island, as with the Proposed Project.

It is assumed that development would occur on the same general footprints as for the Proposed Project on Treasure Island and Yerba Buena Island, and that there would be a larger number of 3- to 6-story buildings and fewer high-rise buildings than with the Proposed Project, since nearly 3,000 fewer residential units would be constructed. The footprint of development would be slightly altered compared to the Proposed Project because this alternative would not develop Blocks E5 and E7 in the Eastside District (see Figure IV.A.2: Proposed Land Use Plan for Treasure Island, in Section IV.A, Land Use and Land Use Planning, p. IV.A.17, for development block numbers on Treasure Island), and the *U.S.S. Buttercup* training facility would be retained in place. This facility is identified as an historical resource for the purposes of CEQA; thus, the No Ferry Alternative would preserve the structure identified as historically important that would be demolished with the Proposed Project.

Geotechnical stabilization would occur in the same manner and over the same area of Treasure Island as with the Proposed Project, except for blocks E5 and E7. Existing utilities would be replaced, and a Transit Hub would be provided in the Island Center District on Treasure Island. The Ferry Terminal would not be built. Dredging for the ferry basin would not occur.

This alternative would provide for bus service similar to that described in Mitigation Measure M-TR-2, Expanded Transit Service, for the Proposed Project, which provides for more frequent service to San Francisco during the peak hours and two bus routes serving the Transbay Terminal area and the Civic Center area. Bus service to downtown Oakland would be the same as described for the Proposed Project. It is assumed that funding to provide the additional buses and operators for increased bus service to San Francisco would be available because there would be no Ferry Terminal construction, and no need to lease ferry boats or provide project-generated funding for ferry operations.

As for the Proposed Project, the No Ferry Service Alternative would include conveyance of NSTI by the Navy to TIDA and would be subject to the same provisions of the Tidelands Trust Conversion Act. The No Ferry Service Alternative would require the same or similar amendments to the *San Francisco General Plan* and the Planning Code. Height limits and design guidelines would be modified in the SUD and *Design for Development* compared to those included in the Proposed Project, based on constructing substantially fewer residential units and building types; the same approval actions related to adopting a redevelopment plan would be necessary as those needed for the Proposed Project. Subdivision actions and an interagency cooperative agreement among various San Francisco City agencies would be needed for this alternative, as for the Proposed Project. Approval of a system of ramp meters at the Bay Bridge on-ramps would continue to be needed if the ramp meters were located on Caltrans property, and congestion pricing would still be implemented. Approvals necessary to construct and operate the ferry terminal, including actions by the U.S. Army Corps of Engineers, RWQCB,

and BCDC, and approvals and operation of the ferry service by WETA would not be required for the No Ferry Service Alternative.

The No Ferry Service Alternative could feasibly meet most of the key objectives of the project sponsors, presented in Section II.B, Project Sponsors' Objectives. However, without ferry service, this alternative would provide 2,900 fewer residential units and fewer transit options for residents of the Islands than the Proposed Project. It would provide less encouragement for non-residents to visit the Islands, such that the Islands could be less attractive as a residential community and regional destination than the Proposed Project. In addition, as with the Reduced Development Alternative, fewer residential units under this alternative could reduce some of the economic efficiencies that higher density residential could provide in achieving key project objectives (e.g., providing public amenities and infrastructure and transit improvements; providing affordable housing; and creating a community of sufficient size to support neighborhood-serving retail, community facilities, and transit).

ENVIRONMENTAL ANALYSIS

Land Use and Land Use Planning

The land use impacts of the No Ferry Service Alternative would be similar to those described for the Proposed Project in Section IV.A, Land Use and Land Use Planning. The same types of land uses would be developed under this alternative, but the density of development would be reduced, there would be no Ferry Terminal or ferry service, and there would be 2,900 fewer residential units and slightly more open space. Like the Proposed Project, the No Ferry Service Alternative would not physically divide an established community, would not have a substantial adverse impact on the character of the vicinity, and would not have a substantial adverse impact on the character of land uses subject to the Tidelands Trust Doctrine. As with the Proposed Project, there would be no significant environmental impacts related to land use under this alternative, and no mitigation is required.

Aesthetics

Under the No Ferry Service Alternative, impacts related to aesthetics would be similar in character to those described for the Proposed Project in Section IV.B, Aesthetics, but lessened somewhat in magnitude given the reduced density of new construction overall under this alternative.

There would likely be fewer towers on Treasure Island under this alternative given the reduced number of residential units (about five fewer towers than the 19 towers under the Proposed Project). These would likely be lower in height and spaced farther apart on Treasure Island. As with the Proposed Project, the No Ferry Service Alternative would continue to result in a

prominent cluster of high-rise buildings at the center of San Francisco Bay. It would be particularly prominent from public vantage points along the eastern shoreline of San Francisco, Telegraph Hill, the East Bay shoreline, and from the Bay Bridge east span. Implementation of this alternative would lessen, but not avoid, a significant impact on scenic vistas compared to the Proposed Project.

As with the Proposed Project, a *Design for Development* would be implemented to establish specific requirements for buildings, streets, open spaces, and landscaping to encourage high-quality design and materials, an inviting pedestrian-orientation, and visual variety and interest. As with the Proposed Project, impacts related to visual quality and scenic resources under this alternative would be less than significant, and no mitigation is required.

Impacts related to light and glare would be similar in character to those described for the Proposed Project, but lessened somewhat in magnitude given the reduced density of new construction overall under the No Ferry Service Alternative. As with the Proposed Project, impacts related to light and glare would be less than significant, and no mitigation is required.

In summary, the No Ferry Service Alternative would reduce the number of residential units and, therefore, the height and number of residential towers. Aesthetic impacts on scenic vistas would be slightly reduced in comparison to the Proposed Project, but impacts on scenic vistas would remain significant and unavoidable.

Population and Housing

Under the No Ferry Service Alternative, the number of residential units would be reduced to 5,100 (2,900 fewer units than the Proposed Project). All remaining land uses would be the same as the Proposed Project. There would be a total residential population of about 11,880 people by 2030, about 6,760 fewer people than with the Proposed Project. Like the Proposed Project, the population would increase, although this increase would not be beyond expected growth incorporated into local and regional planning efforts and employment and housing forecasts.

With implementation of the No Ferry Service Alternative, non-residential employment-generating land uses would be the same as in the Proposed Project. There would be about 2,920 employees (2,600 net new). Therefore, as with the Proposed Project, employment under this alternative would not create a substantial demand for housing in the neighborhood, San Francisco, or the region, in excess of the housing provided as part of the alternative or housing otherwise available in the Bay Area. The amount of housing provided by the No Ferry Service Alternative would continue to exceed demand generated by project employees. Therefore, similar to the Proposed Project, project-level and cumulative impacts on population and housing would be less than significant under the No Ferry Service Alternative, and no mitigation measures are required.

Cultural and Paleontological Resources

Under the No Ferry Service Alternative, impacts related to archaeological and paleontological resources would be similar in character to those described for the Proposed Project in Section IV.D.1, Archaeological and Paleontological Resources. The same ground-disturbing, geotechnical stabilization work would take place under this alternative as described for the Proposed Project in Chapter II, Project Description. Slightly less area of ground would be disturbed under this alternative because Blocks E-5 and E-7 would not be developed since the *U.S.S. Buttercup* historical resource would be retained. Ground disturbance could also be reduced somewhat with the potential for a reduced number of off-street structured parking spaces required for this alternative, and because no harbor dredging would be necessary under this alternative. The same mitigation measures identified for the Proposed Project would apply to this alternative to reduce potential impacts on archaeological and paleontological resources to a less-than-significant level.

The *U.S.S. Buttercup* training facility, located at 320 Avenue M near the corner of Fourth Street, is evaluated for its significance under California Register of Historical Resources criteria in Section IV.D.2, Historic Architectural Resources. That section concludes that it is individually eligible for inclusion in the California Register and is therefore considered an historical resource for the purposes of CEQA. On this basis, that section concludes that demolition of the *U.S.S. Buttercup* historical resource under the Proposed Project would result in a material adverse change in the significance of a historical resource under CEQA. With the No Ferry Service Alternative, the *U.S.S. Buttercup* would be retained. It is also assumed under this alternative that the *U.S.S. Buttercup* would be stabilized and repaired in conformity with the *Secretary of the Interior's Standards for Rehabilitation*, and that the resource would be made accessible to the public as part of the recreational program.

Retention and reuse of the *U.S.S. Buttercup* under the No Ferry Service Alternative would avoid the significant impact resulting from the demolition of this individual historical resource under the Proposed Project.

Transportation

The No Ferry Service Alternative would include the same transportation improvements as the Proposed Project as described in Section IV.E, Transportation, beginning on p. IV.E.30, with the exception that ferry service between Treasure Island and downtown San Francisco would not be provided. Instead, this alternative assumes that funding would be available to provide the amount of bus service to San Francisco and the East Bay that is described in Mitigation Measure M-TR-2, Expanded Transit Service, on p. IV.E.74.

With the No Ferry Service Alternative, the number of residential units would be 5,100 units, compared to 8,000 units included in the Proposed Project (2,900 fewer units). The No Ferry Service Alternative would include approximately 2,900 fewer parking spaces than the Proposed Project. All other land uses would be the same as the Proposed Project. Therefore, compared to the Proposed Project, the No Ferry Service Alternative would generate fewer person- and vehicle trips.

Eliminating ferry service would reduce transit capacity between the Islands and San Francisco, but the capacity would be made up by the expanded bus service described in Mitigation Measure M-TR-2. With the expanded bus service, the No Ferry Service Alternative would result in a slightly higher overall transit mode share compared to the Proposed Project. The number of vehicle trips generated by the No Ferry Service Alternative would be less than the number generated by the Proposed Project, but similar to the number generated by the Proposed Project with implementation of Expanded Transit Service described in Mitigation Measure M-TR-2.

Construction

Construction activities associated with the No Ferry Service Alternative would be similar to the Proposed Project, but somewhat reduced due to the lesser amount of overall development, with fewer residential units and no Ferry Terminal. Mitigation Measure M-TR-1, a Construction Management Plan, would minimize the alternative's contribution to construction-related traffic impacts; however, some disruption and increased delays would still occur even with implementation of Mitigation Measure M-TR-1, and, as with the Proposed Project, construction-related traffic impacts would remain significant and unavoidable.

Traffic

The No Ferry Service Alternative would result in significant and unavoidable impacts related to extensive queues and vehicle delays at the same study ramp locations as the Proposed Project.

The impacts would be similar to the Proposed Project with implementation of Mitigation Measure M-TR-2. The No Ferry Service Alternative would result in significant and unavoidable impacts at the following ramp locations:

- At the eastbound off-ramp on the west side of Yerba Buena Island;
- Under conditions without the Ramps Project, at the two westbound on-ramps; and
- Under conditions with the Ramps Project, at the ramp meter at the westbound on-ramp at the east side of Yerba Buena Island.

As for the Proposed Project, under conditions without and with the Ramps Project, the No Ferry Service Alternative would result in less-than-significant impacts at the eastbound on-ramp and

eastbound off-ramp on the east side of Yerba Buena Island, and the westbound off-ramp on the east side of Yerba Buena Island. The No Ferry Service Alternative would also result in a significant impact on queuing at the Bay Bridge toll plaza during the weekday AM peak hour, and on San Francisco streets approaching the Bay Bridge during the PM peak hour, although the magnitude would be less than the Proposed Project because the amount of vehicular traffic generated would be less.

Implementation of the No Ferry Service Alternative would result in significant impacts on the same study intersections as for the Proposed Project (the intersection LOS would be the same as presented in Table IV.E.15 for the Proposed Project, although delay would be less and more similar to the Proposed Project with implementation of Mitigation Measure M-TR-2 discussed throughout the Impacts section of Section IV.E, Transportation). The results indicate that the No Ferry Service Alternative would result in significant impacts at nine study intersections.

- The No Ferry Service Alternative would result in project-specific impacts at six signalized study intersections that operate at LOS D or better under Existing conditions and would deteriorate to LOS E or LOS F under Existing plus Project conditions, or that operate at LOS E under Existing conditions and would deteriorate to LOS F under Existing plus Project conditions (First/Market, First/Mission, First/Folsom, First/Harrison/I-80 Eastbound On-Ramp, Bryant/Fifth/I-80 Eastbound On-Ramp, Fifth/Harrison/I-80 Westbound Off-Ramp).
- The No Ferry Service Alternative would contribute considerably to critical movements at one signalized study intersection that operates at LOS E or LOS F under Existing conditions and would continue to operate at LOS E or LOS F under Existing plus Project conditions (Second/Folsom).
- The No Ferry Service Alternative would have less-than-significant contributions at three signalized study intersections that operate at LOS E or LOS F under Existing conditions and that would continue to operate at LOS E or LOS F under Existing plus Project conditions (First/Howard, Essex/Harrison/I-80 Eastbound On-Ramp, The Embarcadero/Harrison).
- The No Ferry Service Alternative would have less-than-significant contributions at five signalized study intersections that would operate at LOS D or better under Existing plus Project conditions (Fremont/Howard, Fremont/Folsom, Fremont/I-80 Westbound Off-Ramp/Harrison, Second/Bryant, Avenue of Palms/First Street).
- The No Ferry Service Alternative would contribute considerably to two uncontrolled study intersections that operate poorly under Existing conditions, resulting in a project-specific impact (Folsom/Essex and Bryant/Sterling).

If the anticipated transit mode share is not attained by the alternative, the potential exists that additional vehicle trips would be generated by the No Ferry Service Alternative, which could result in greater vehicle delays than identified for the Proposed Project. If the bus transit use is less than projected, additional transit service may need to be provided to increase the transit mode share and reduce vehicle delays and poor operating conditions.

Transit

The No Ferry Service Alternative transit conditions assume implementation of Project-related transit improvements as described in Section IV.E, Transportation, on p. IV.E.93, with the exception of ferry service that would not be provided. Instead, this alternative assumes that funding would be available to provide the amount of bus service to San Francisco and the East Bay that is described in Mitigation Measure M-TR-2, the Expanded Transit Service. Thus, the amount of bus service to San Francisco in this alternative would be greater than that for the Proposed Project. Therefore, with implementation of the No Ferry Service Alternative, the additional bus service would accommodate the shift in transit demand from ferry to bus, and the transit capacity utilization standard of 85 percent on Muni's 108-Treasure Island bus line serving the Islands would not be exceeded. Based on this projection, the No Ferry Service Alternative would result in a less-than-significant impact on the capacity of the Muni 108-Treasure Island. Similar to the Proposed Project, impacts on the new AC Transit bus service between the Islands and the East Bay, and impacts on other AC Transit, BART, Golden Gate Transit, SamTrans and regional ferry lines would be less than significant. The No Ferry Service Alternative would add fewer transit trips to the Muni downtown San Francisco screenlines than the Proposed Project, and ridership demand would not exceed capacity utilization standards.

- Similar to the Proposed Project, under conditions without and with the Ramps Project, vehicle queues extending from the Bay Bridge on-ramps at Yerba Buena Island would impact Muni line 108-Treasure Island and AC Transit bus operations. With implementation of Mitigation Measure M-TR-24 (Transit and Emergency Vehicle Only Lane) identified in Section IV.E, Transportation, for the Proposed Project (p. IV.E.100), the impact on Muni line 108-Treasure Island operations under conditions without the Ramps Project would be reduced to a less-than-significant level. Implementation of Mitigation Measure M-TR-24 would improve operations for AC Transit buses destined to the eastbound on-ramp. However, since this improvement would extend only to the transit and emergency vehicle-only westbound on-ramp on the west side of Yerba Buena Island, and since sufficient right-of-way is not available to extend a transit-only lane beyond the transit and emergency vehicle-only westbound on-ramp, AC Transit vehicles would continue to experience congestion between the transit and emergency vehicle-only westbound on-ramp and the eastbound on-ramp under conditions with and without the Ramps Project. Therefore, similar to the Proposed Project, the impact to AC Transit operations would remain significant and unavoidable.

As with the Proposed Project, transit impacts would occur from traffic congestion delay in downtown San Francisco. Overall, the transit delay conditions with the No Ferry Service Alternative would affect the same lines as with the Proposed Project (27-Bryant, 30X-Marina

Express, and 47-Van Ness), and would not affect operations of Golden Gate Transit or SamTrans bus lines. Impacts on the Muni bus lines would be significant and unavoidable.

Bicycles

The No Ferry Service Alternative bicycle trips would be accommodated within the proposed street network on the Islands and on mainland San Francisco. In the absence of ferry service, cyclists would be able to travel between the Islands and mainland San Francisco using bicycle racks on the Muni line 108-Treasure Island buses. Similar to the Proposed Project, impacts related to bicycle accessibility would be less than significant, and no mitigation measures are required. Also, as with the Proposed Project, implementation of Mitigation Measure M-TR-24 would result in the removal of the proposed Class II bicycle lane on a portion of Treasure Island and Hillcrest Roads to accommodate a transit-only lane (Mitigation Measure M-TR-24 would only be implemented if queues on Treasure Island Road materialize and substantially affect transit operations). However, cyclists would continue to have a Class II contra flow facility connecting the Islands and the Bay Bridge, via Macalla Road.

Pedestrians

The pedestrian network and improvements would not change materially between the Proposed Project and the No Ferry Service Alternative, and, similar to the Proposed Project, the pedestrian environment would be improved compared to existing conditions. The No Ferry Service Alternative would generate fewer pedestrian trips than the Proposed Project, which would be accommodated within the proposed street network on the Islands. Unlike the Proposed Project, the No Ferry Service Alternative would not be expected to generate pedestrian trips across The Embarcadero at the Ferry Building crosswalks. Similar to the Proposed Project, impacts related to pedestrian accessibility would be less than significant, and no mitigation measures are required.

Loading

Similar to the Proposed Project, development associated with the No Ferry Service Alternative would be subject to freight loading space requirements to accommodate the loading demand, and would be designed to minimize impacts on autos, transit, bicyclists and pedestrians and to ensure that loading activities do not result in hazardous conditions. The No Ferry Service Alternative impacts related to loading operations would be less than significant, and no mitigation measures are required.

Emergency Access

The No Ferry Service Alternative impacts on emergency access would be the same as for the Proposed Project. Local police and fire facilities would provide first response to incidents on the Islands, and existing emergency routes would be maintained in their existing locations or rerouted as necessary. Similar to the Proposed Project, impacts on emergency access would be less than significant, and no mitigation measures are required.

Cumulative Conditions

Although the No Ferry Service Alternative would result in construction of 2,900 fewer residential units and would not include construction of ferry facilities, given the overall magnitude of development, the alternative's prolonged construction period, and the lack of certainty of timing of other projects in the area, the No Ferry Service Alternative would also result in significant contributions to cumulative construction-related traffic impacts.

Under 2030 Cumulative conditions, as with the Proposed Project, the No Ferry Service Alternative would contribute to significant cumulative traffic impacts at the following locations:

- at the eastbound off-ramp on the west side of Yerba Buena Island;
- under conditions without the Ramps Project, at the two westbound on-ramps; and
- under conditions with the Ramps Project, at the ramp meter at the westbound on-ramp at the east side of Yerba Buena Island.

The No Ferry Service Alternative would also result in a significant cumulative impact on queuing at the Bay Bridge toll plaza during the weekday AM and PM peak hours, and on San Francisco streets approaching the Bay Bridge during the weekday AM and PM and Saturday peak hours. As with other significant impacts identified under the No Ferry Service Alternative, the magnitude of the impact would be less than that of the Proposed Project, and more similar to the impacts of the Proposed Project with implementation of Mitigation Measure M-TR-2.

The No Ferry Service Alternative would result in significant impacts at seven study intersections.

- Similar to the Proposed Project, the No Ferry Service Alternative would result in project-specific impacts at six study intersections that would operate at LOS D or better and deteriorate to LOS E or LOS F, or that would operate at LOS E and deteriorate to LOS F under Existing plus Project conditions, although the magnitude of the impact would be reduced (the magnitude would be most similar to the Proposed Project with implementation of Mitigation Measure M-TR-2). Because the No Ferry Service Alternative would result in significant project-specific impacts at these intersections, it would also result in cumulative impacts at these intersections (First /Market, First/Mission, First/Folsom, First/Harrison/I-80 Eastbound On-Ramp, Bryant/Fifth/I-80 Eastbound On-Ramp, Fifth/Harrison/I-80 Westbound Off-Ramp).

- The No Ferry Service Alternative would contribute considerably to critical movements at one study intersection that would operate at LOS E or LOS F under 2030 Cumulative No Project conditions, resulting in a project impact (Second/Folsom).
- The No Ferry Service Alternative would have less-than-significant contributions at seven study intersections that would operate at LOS E or LOS F under 2030 Cumulative No Project conditions (Fremont/Howard, Fremont/Folsom, Fremont/I-80 Westbound Off-Ramp/Harrison, First/Howard, Essex/Harrison/I-80 Eastbound On-Ramp, Second/Bryant, The Embarcadero/Harrison).
- The No Ferry Service Alternative would contribute considerably to significant cumulative impacts at the two uncontrolled study intersections (Folsom/Essex and Bryant/Sterling).

Under 2030 Cumulative conditions, implementation of the No Ferry Service Alternative would have significant impacts to the same transit system components as the Proposed Project except that Muni capacity utilization would not be exceeded under the No Ferry Service Alternative, and the magnitude of the No Ferry Service Alternative impacts would be reduced compared to the Proposed Project. The No Ferry Service Alternative would add more transit trips to the Muni downtown San Francisco screenlines than the Proposed Project but fewer than the Proposed Project with implementation of Mitigation Measure M-TR-2. As a result, ridership demand would not exceed capacity, and impacts on the downtown San Francisco screenlines would be less than significant. Transit impacts from cumulative traffic congestion delay in downtown San Francisco would affect the same lines as the Proposed Project (10-Townsend, 27-Bryant, 30X-Marina Express, and 47-Van Ness). Increased traffic congestion delay in downtown San Francisco would not affect operations of Golden Gate Transit or SamTrans bus lines.

Parking Information

Similar to the Proposed Project, development associated with the No Ferry Service Alternative would be subject to parking space maximums. The No Ferry Service Alternative would include 2,900 fewer residential units and residential parking spaces than the Proposed Project. Therefore, similar to the Proposed Project, the No Ferry Service Alternative would result in a parking deficit for both residential and non-residential uses. However, parking shortfalls are not considered to be physical environmental impacts under CEQA.

As with the Proposed Project, implementation of the parking supply maximums would result in secondary physical impacts caused by increased traffic congestion and a mode shift to transit that would exacerbate the exceedance of capacity utilization standards on Muni's 108-Treasure Island bus line. As noted above, the No Ferry Service Alternative includes the expanded bus service to San Francisco and the East Bay that is described in Mitigation Measure M-TR-2. Expansion of M-TR-2, such as provision of additional bus routes to San Francisco, would minimize but not eliminate the No Ferry Service Alternative's impacts on transit capacity utilization, and the effects on transit related to secondary impacts would remain significant and unavoidable.

Noise

The No Ferry Service Alternative would result in similar construction activities as would occur with the Proposed Project. Deep dynamic compaction and vibro-compaction would occur generally to the same degree as the Proposed Project. Pile driving for the Ferry Terminal would not occur and there may be a reduced amount of pile driving for construction of multi-story residential buildings due to the reduced number of residential units and the reduced height of residential buildings under this alternative. Noise impacts from non-impact equipment and construction truck trips would be similar to those of the Proposed Project. As with the Proposed Project, Mitigation Measures M-NO-1a and M-NO-2 (pp. IV.F.16 and IV.F.20) could be implemented to lessen construction-related noise impacts; however, noise from impact equipment would be of reduced duration but would still represent a significant unavoidable noise and vibration impact.

The No Ferry Service Alternative would develop the same land uses, but with fewer residential units. Bus service would be the same as the Proposed Project assuming implementation of Mitigation Measure M-TR-2, Expanded Transit Service. Operational noise impacts from ferry operations at the Transit Hub would not occur. Therefore, operational noise impacts due to ferry operations identified for the Proposed Project would not occur under this alternative.

Although there would be less residential development under the No Ferry Service Alternative, local roadway traffic volumes would be similar to the Proposed Project with Expanded Transit Service, as the removal of the proposed ferry trips is assumed to result in an increase in vehicle trips.¹⁰ Consequently, the roadway noise impacts of this alternative would be the same as or similar to those identified for the Proposed Project, and would be significant and unavoidable. This would also be true of cumulative roadway noise impacts.

Air Quality

Under the No Ferry Service Alternative, the same construction activities would occur as under the Proposed Project. The same type of diesel powered construction equipment and truck trips would be generated. Fugitive construction dust would also be generated from excavation and movement of truck and equipment both on-road and off-road. Although there would be no construction of the Ferry Terminal and the overall duration of construction would be reduced with fewer residential units included, peak daily construction activities would be the same as the Proposed Project under the No Ferry Service Alternative. Like the Proposed Project, fugitive dust emissions from construction activities would be less than significant with incorporation of BAAQMD-identified mitigation measures.

¹⁰ Henry, Todd, Transportation Planner, Fehr & Peers, Letter to Viktoriya Wise, Francisco Planning Department, February 6, 2010.

Daily criteria pollutant emission estimates from construction would be similar to those calculated for the Proposed Project, and would remain significant and unavoidable under this alternative, although construction activities for the Ferry Terminal would not occur, which would reduce construction emissions during Phase 1. Health risks from diesel particulate matter and PM2.5 would also be the same as the Proposed Project and would remain significant and unavoidable, even with implementation of Mitigation Measure M-AQ-3.

The No Ferry Service Alternative would develop the same land uses as the Proposed Project, with fewer residential units. Operational emissions from increased vehicle trip generation compared to existing conditions would, however, be similar to those of the Proposed Project with the Expanded Transit Service mitigation measure, because removal of the proposed ferry trips is assumed to result in an increase in the number of vehicle trips commensurate with the reduction in transit service.¹¹ Operational air quality emissions from the Transit Hub associated with ferry trips would not occur, unlike in the Proposed Project.

Table VII.17, p. VII.64, presents the modeled air emissions that would occur with the Proposed Project and with development of the No Ferry Service Alternative. As can be seen from this table, the No Ferry Service Alternative would reduce ROG emissions by 35 percent, NOx emissions by 64 percent, PM10 emissions by 24 percent, and PM2.5 emissions by 27 percent compared to the Proposed Project. However, the impacts would remain significant and unavoidable.

Motor vehicle trip generation under the No Ferry Service Alternative would be approximately 7 percent less than the Proposed Project. CO concentrations under this alternative would be less than the Proposed Project and would be less than significant, as described for the Proposed Project in Impact AQ-6 (pp. IV.G.43-IV.G.44).

Health risks from exposure to diesel particulate matter (“DPM”) were found to be significant under the Proposed Project with the Expanded Transit Service transportation mitigation measure unless mitigated by diesel particulate filters. These emissions would be generated by both ferries and diesel buses, with approximately 89 percent of DPM emissions attributable to ferries. Without the contribution of ferry emissions, cancer risk attributable to DPM emissions would be the result of buses alone. The maximum incremental residential cancer risk from the No Ferry Service Alternative would be 8.3 in one million with application of age sensitivity factors. Consequently, health risk impacts related to DPM exposure would be substantially reduced under the No Ferry Service Alternative compared to the Proposed Project and no mitigation is required.

¹¹ Henry, Todd, Transportation Planner, Fehr & Peers, Letter to Viktoriya Wise, San Francisco Planning Department, February 6, 2010.

Health risks from exposure to project-generated fine particulate matter¹² (“PM2.5”) were found to be less than significant under the Proposed Project and would be further reduced by diesel particulate filters identified as mitigation for DPM impacts. These emissions would be generated by both ferries and diesel buses, as well as by motor vehicles. The No Ferry Service Alternative would result in reduced numbers of motor vehicle and bus trips compared to those of the Proposed Project and would have no emissions from ferry vessels. Consequently, health risk impacts related to PM2.5 exposure would be less under this alternative than under the Proposed Project and would also be less than significant. Health risk impacts to new residents on Yerba Buena Island from exposure to PM2.5 from existing mobile sources on the Bay Bridge would be the same under the Proposed Project and the No Ferry Service Alternative, although the number of new receptors exposed to high levels of PM2.5 might be less if fewer residential units were constructed on Yerba Buena Island with this alternative.

There would be no differences between the No Ferry Service Alternative and the Proposed Project with regard to existing or proposed odor sources. Odor impacts, like those under the Proposed Project would be less than significant under this alternative.

There would be no differences between the No Ferry Service Alternative and the Proposed Project with regard to consistency with the Bay Area Clean Air Plan (CAP). CAP consistency impacts, like those under the Proposed Project would be significant under this alternative, as the rate of increase in vehicle miles travelled under this alternative (0.47 percent) would be greater than the rate of increase in population (0.41 percent).

While both the Proposed Project and the No Ferry Service Alternative would have significant cumulative air quality impacts, the contribution to that cumulative impact would be substantially lower under the No Ferry Service Alternative than under the Proposed Project.

Greenhouse Gases

Under the No Ferry Service Alternative, similar construction activities would occur as under the Proposed Project. The same type of diesel powered construction equipment and truck trips would be generated but materials delivery truck trips would be reduced as the number of residential units constructed would be reduced. There would also be no construction of the Ferry Terminal under this alternative, so construction-related GHG emissions over the entire duration of construction would be reduced under the No Ferry Service Alternative, even if emissions on a peak daily basis would be similar.

¹² This refers to localized exposures to concentrations of PM2.5, not mass daily emissions of PM2.5, which is a regional impact.

Table VII.17: Estimated Daily Emissions for the Proposed Project and the No Ferry Service Alternative

Emission Source	Estimated Daily Emissions (pounds per day)					
	ROG	NOx	CO ^a	SO ₂	PM10	PM2.5
Proposed Project (2030)						
On Site Natural Gas	2	26	22	<1	<1	<1
Landscape Equipment	1	<1	18	<1	<1	<1
Consumer Products	392	NA	NA	NA	NA	NA
Architectural Coating	66	NA	NA	NA	NA	NA
Motor Vehicles	130	97	1,047	3	517	97
Buses	1	29	4	<1	3	1
Ferries	21	290	136	<1	8	7
Shuttle Buses	2	15	9	<1	<1	<1
Total Proposed Project (2030)	615	457	1,236	3	528	105
<i>1999 BAAQMD Threshold</i>	80	80	550	NA	80	NA
Significant?	Yes	Yes	Yes	No	Yes	NA
<i>2010 BAAQMD Threshold</i>	54	54	NA	NA	82	54
Significant?	Yes	Yes	NA	NA	Yes	Yes
No Ferry Service Alternative (includes Expanded Transit level of bus service) (2030)						
On Site Natural Gas	1	17	14	<1	<1	<1
Landscape Equipment	2	<1	19	<1	<1	<1
Consumer Products	250	NA	NA	NA	NA	NA
Architectural Coating	47	NA	NA	NA	NA	NA
Motor Vehicles	96	74	798	2	396	74
Buses	2	57	8	<1	5	3
Ferries	0	0	0	0	0	0
Shuttle Buses	2	15	9	<1	<1	<1
Total No Ferry Service Alt (2030)	400	163	848	2	401	77
<i>1999 BAAQMD Threshold</i>	80	80	550	NA	80	NA
Significant?	Yes	Yes	Yes	No	Yes	No
<i>2010 BAAQMD Threshold</i>	54	54	NA	NA	82	54
Significant?	Yes	Yes	No	No	Yes	Yes
Proposed Project with Expanded Transit Service (2030)						
On Site Natural Gas	2	26	22	<1	<1	<1
Landscape Equipment	1	<1	18	<1	<1	<1
Consumer Products	392	NA	NA	NA	NA	NA
Architectural Coating	66	NA	NA	NA	NA	NA
Motor Vehicles	115	81	879	2	434	82
Buses	2	57	8	<1	5	3
Ferries	62	871	409	<1	23	22
Shuttle Buses	2	15	9	<1	<1	<1

(continued)

Table VII.17: (continued)

Emission Source	Estimated Daily Emissions (pounds per day)					
	ROG	NOx	CO ^a	SO ₂	PM10	PM2.5
Total Proposed Project with Expanded Transit Service (2030)	642	1,050	1,345	2	462	107
<i>1999 BAAQMD Threshold</i>	<i>80</i>	<i>80</i>	<i>550</i>	<i>NA</i>	<i>80</i>	<i>NA</i>
Significant?	Yes	Yes	Yes	No	Yes	NA
<i>2010 BAAQMD Threshold</i>	<i>54</i>	<i>54</i>	<i>NA</i>	<i>NA</i>	<i>82</i>	<i>54</i>
Significant?	Yes	Yes	NA	NA	Yes	Yes

Note:

^a The 1999 BAAQMD CEQA Guidelines state that exceeding the 550 pound-per-day CO threshold does not necessarily reflect a significant CO impact but rather, triggers a modeling assessment of localized CO concentrations to determine significance. This modeling analysis is addressed for the Proposed Project in Section IV.G, Air Quality, in Impact AQ-6, and shows that the Proposed Project, with Expanded Transit Service, would not exceed State or Federal CO standards. The No Ferry Service Alternative (including Expanded Transit Service) would result in less CO emissions than would the Proposed Project with Expanded Transit Service, and therefore would also not exceed CO standards.

Source: ESA 2010

The No Ferry Service Alternative would develop the same land uses as the Proposed Project, but with fewer residential units. Operational GHG emissions from increased vehicle trip generation (compared to existing conditions) would be less than both the Proposed Project and those from the Proposed Project with implementation of Mitigation Measure M-TR-2 (Expanded Transit Service), as the reduction in residential development would more than compensate for the increase in vehicle use which would result from the absence of ferry service. Operational GHG emissions from the Transit Hub would be reduced with no ferry vessel operations, although bus service would be increased to the same level as under the Proposed Project with Expanded Transit Service. Table VII.18 presents the modeled air emissions that would occur with the development of the No Ferry Service Alternative and compares them to the Proposed Project and to the Proposed Project with Expanded Transit Service.

As can be seen from Table VII.18, this alternative would reduce operational GHG emissions by 27 percent compared to the Proposed Project. Table VII.18 shows that the alternative would reduce operational GHG emissions by 26 percent compared to the Proposed Project with the Expanded Transit Service mitigation measure.

Table VII.18: Emissions of GHG from the Proposed Project and No Ferry Service Alternative

Emission Source/Sink	Emissions (metric tons CO ₂ e per year)			
	CO ₂	CH ₄	N ₂ O	Total CO ₂ e
Proposed Project				
Motor vehicle trips	45,431	139	2,729	48,299
Buses	971	--	1	972
Ferries	3,215	5	26	3,246
Shuttle Buses	247	5	6	258
Natural gas	5,188	10	3	5,201
Grid Electricity	--	--	--	1,030
Solid Waste generation	--	--	--	4,544
Water Conveyance	452	--	2	455
Wastewater Treatment & Conveyance	On-island WWTP Treatment & Conveyance Energy included in Grid Electricity Above (inclusive of stormwater and recycled water)			
Area Source (landscape maintenance)	3	--	--	3
Total Proposed Project Operational Greenhouse Gas Emissions				64,008
No Ferry Service Alternative				
Motor vehicle trips	34,777	106	2,092	36,974
Buses	1,905	--	1	1,906
Ferries	0	0	0	0
Shuttle Buses	247	5	6	258
Natural gas	3,306	7	3	3,316
Grid Electricity	--	--	--	775
Solid Waste generation	--	--	--	3,489
Water Conveyance	288	1	1	290
Wastewater Treatment & Conveyance	On-island WWTP Treatment & Conveyance Energy included in Grid Electricity Above (inclusive of stormwater and recycled water)			
Area Source (landscape maintenance)	3	--	--	3
Total No Ferry Service Alternative Operational Greenhouse Gas Emissions (includes Expanded Transit level of bus service)				47,011
Proposed Project with Expanded Transit Service				
Motor vehicle trips	38,147	116	2,292	40,555
Buses	1,905	--	1	1,906
Ferries	9,645	15	77	9,737
Shuttle Buses	247	5	6	258
Natural gas	5,188	10	3	5,201
Grid Electricity	--	--	--	1,030
Solid Waste generation	--	--	--	4,544
Water Conveyance	452	--	2	455
Wastewater Treatment & Conveyance	On-island WWTP Treatment & Conveyance Energy included in Grid Electricity Above (inclusive of stormwater and recycled water)			
Area Source (landscape maintenance)	3	--	--	3
Total Proposed Project with Expanded Transit Service Operational Greenhouse Gas Emissions				63,689

Source: ESA, 2010

Wind and Shadow

The No Ferry Service Alternative would have the same street grid and a similar organization of low- and mid-rise buildings as the Proposed Project, but it could potentially have approximately

five fewer towers than the 19 high-rise towers in the Proposed Project. As a direct result of having the same street grid and a similar organization of low- and mid-rise buildings, the No Ferry Service Alternative would cause overall shadowing of adjacent streets, sidewalks, and neighborhood open spaces that would be generally the same as the shadowing from the Proposed Project. However, with fewer towers, there would be less transitory shadow reaching into the alternative's larger open spaces from the towers, primarily during the early mornings and late afternoons during the spring, autumn, and winter months.

As a result of having the same street grid and a similar organization of low- and mid-rise buildings, the No Ferry Service Alternative would result in overall reductions in wind speed in the interior of the development, similar to the Proposed Project, while wind conditions at the outer edges of the built areas would remain very windy. It is anticipated that the reductions in the wind speeds would be similar to, but of lesser magnitude, than those of the Proposed Project. It is anticipated that reductions in the number and duration of the existing wind hazards that would occur with the Proposed Project would also occur with the No Ferry Service Alternative. As with the Proposed Project, under the No Ferry Service Alternative, the occurrence of wind hazards would be higher along the development's outer edges and the relative frequency of wind hazards generally would diminish in its interior, except for the particular wind effects of open exposures to winds from the Bay, the pedestrian-level wind effects of tall buildings, or the effects of strong incident winds channeling between the building masses and along the streets. Mitigation Measures M-WS-3 and M-SW-4 similar to those identified for the Proposed would be available to address hazardous wind impacts of the No Ferry Service Alternative. However, it may not be possible to mitigate all wind hazards, existing or new, to less-than-significant levels. Thus, even with implementation of Mitigation Measures M-WS-3 and M-WS-4 to reduce hazardous wind impacts, the wind impacts of the No Ferry Service Alternative, like those of the Proposed Project, would be considered to be significant and unavoidable.

Recreation

The No Ferry Service Alternative would provide 306 acres of parks and open space on Treasure Island and Yerba Buena Island, six more acres than would be included in the Proposed Project. A Habitat Management Plan would be implemented for much of the undeveloped portions of Yerba Buena Island, as it would for the Proposed Project.

The No Ferry Service Alternative would provide an integrated system of neighborhood- and region- serving parks and playgrounds, open spaces such as public plazas, courtyards, and cultural areas, athletic fields, and greenways, as would the Proposed Project. However, because this alternative would result in 6,760 fewer residents, it would provide more parks and open space per resident than the Proposed Project would - more than 27 acres of parks and open space per 1,000 residents, compared to about 17 acres with the Proposed Project. Ratios for both the

Proposed Project and this alternative are higher than the current Citywide ratio of about 8 acres of parks and open space per 1,000 residents. The No Ferry Service Alternative would generate approximately 2,920 jobs, the same as the Proposed Project, which could result in a maximum daytime population of up to approximately 14,800 (adding the residential population of about 11,880 and assuming that no residents were employed off site, which is unlikely). Counting the entire daytime population as a part of the population served by the parks and open space in the Development Plan Area, the parks and open space-to-population ratio would be more than 20 acres per 1,000 employees and residents, compared to a daytime population ratio of 14 acres for the Proposed Project. Soccer pitches, baseball diamonds, and other athletic fields (as part of the 25- to 40-acre Sports Park) would be provided in this alternative, as they would for the Proposed Project which would help the City meet the existing unmet demand for 35 additional soccer fields and 30 additional baseball/softball fields, as discussed in Section IV.J, Recreation.

Public health concerns about the use of recycled rubber tires as a base material for synthetic turf fields as well as the use of synthetic grass blades discussed for the Proposed Project (see pp. IV.J.21-IV.J.25) would be applicable under the No Ferry Service Alternative and the impact would remain less than significant. As with the Proposed Project, these potential concerns could be minimized with implementation of Improvement Measure I-RE-1.

The No Ferry Service Alternative would not cause substantial physical degradation of other City or regional recreation facilities or resources, or involve construction of recreation facilities that would adversely affect the environment. Therefore, as with the Proposed Project, the No Ferry Service Alternative would have less-than-significant impacts on recreation, and no mitigation measures are required.

Utilities and Service Systems

The No Ferry Service Alternative would have less overall development and, therefore, less demand for certain services, and consequently, slightly smaller infrastructure needs.

Under the No Ferry Service Alternative, new or upgraded wastewater, recycled water, stormwater, water supply, electricity, natural gas, and telecommunications infrastructure would be installed, similar to those planned under the Proposed Project. Construction of these infrastructure improvements could result in impacts on air quality, noise, water quality, transportation, hazardous materials, and biological resources, as discussed under appropriate topics for this alternative. Because some of the infrastructure may be slightly smaller than that for the Proposed Project, construction impacts in some cases could be correspondingly smaller in scale or duration; however, the reduced scale would not be expected to substantially reduce any significant construction impacts identified for the Proposed Project.

The No Ferry Service Alternative would include a new or upgraded wastewater collection and treatment system, a new stormwater collection and treatment system, and a recycled water system, as would the Proposed Project. Various tanks, pipes, or other equipment would be slightly smaller because less wastewater would be generated, but the impact analysis and conclusions would be the same as those identified for the Proposed Project for all three of these systems.

Demand for potable water would be less than that described for the Proposed Project. Various tanks, pipes, or other equipment would be slightly smaller because of lower demand. The impact analysis regarding water supply would not be qualitatively different from that for the Proposed Project, and sufficient water would be available through the SFPUC's Regional Water System to serve the development in this alternative. As with the Proposed Project, no significant impacts on water supply would result.

Solid waste generation would be less than that under the Proposed Project. The conclusions of the impact analysis would not change for the No Ferry Service Alternative

New electricity, natural gas, and telecommunications infrastructure would be installed. Particular distribution lines and equipment might be somewhat smaller, due to lower demand. The impact analysis and conclusions would be the same as those for the Proposed Project.

In summary, as with the Proposed Project, there would be less than significant environmental impacts associated with operating the utilities and service systems under the No Ferry Service Alternative. No mitigation is required.

Public Services

Compared to the Proposed Project, the No Ferry Service Alternative would require similar police and fire staffing levels at the new combined police and fire station, because staffing levels are based in part on the number of residents, and in part on the expected number of emergency calls that would result. Response times for police and fire protection services would also be similar. Under this alternative, the new combined police and fire station would be constructed on Treasure Island in the same central location, and the recycled water firefighting system would be installed. The No Ferry Service Alternative would have less-than-significant impacts on police and fire and emergency services, similar to those described for the Proposed Project in Section IV.L, Public Services, and no mitigation is required.

In this alternative, the Treasure Island School would be renovated or rebuilt, and the existing educational programs would need to be relocated, as they would for the Proposed Project. Since there would be fewer students located on the Islands, fewer high school students would be added to the expected future shortfall of high school classroom space in the SFUSD system, and more

off-Islands elementary and middle school students could be accommodated at the Treasure Island School. As with the Proposed Project, these impacts would be less than significant, and no mitigation is required.

As with the Proposed Project, hospitals and libraries would have sufficient capacity to serve the Islands' additional residents.

Overall, the No Ferry Service Alternative would have less-than-significant impacts on public services, similar to those described for the Proposed Project in Section IV.L, Public Services.

Biological Resources

Compared to the Proposed Project, the No Ferry Service Alternative would lessen the offshore construction impacts on biological resources identified for the Proposed Project because the Ferry Terminal would not be constructed. As a result, construction noise and exposure to surface runoff, contaminants from onshore demolition and construction activities would not occur. However, other offshore construction impacts similar to those of the Proposed Project would continue to occur under this.

The reduced footprint and number of residents would lessen the human-induced wildlife disturbance such as foot traffic, off-leash dogs and feral cats somewhat. A Habitat Management Plan for Yerba Buena Island is assumed to be part of the No Ferry Service Alternative and its expected improvements for habitat structure, biodiversity and stability on the island would be realized.

The significant impact of ferry service operation on rafting waterfowl identified for the Proposed Project would be eliminated under this alternative because ferry service would not be provided. Mitigation Measure M-BI-4b: Changes in Ferry Service to Protect Rafting Waterbirds, identified for the Proposed Project to reduce these impacts to a less-than-significant level, is outside the jurisdiction of the City because the ferry service would be operated by WETA, the responsible agency. This impact, therefore, was considered significant and unavoidable for the Proposed Project.

With ferry service removed as part of the project, biological impacts of the No Ferry Service Alternative would be less-than-significant with implementation of the same mitigation measures (M-B1-1a through 1d, M-B2-2a through 2c, and M-B1-4a) identified for the Proposed Project.

Geology and Soils

The No Ferry Service Alternative would have impacts similar to those identified for the Proposed Project. As with the Proposed Project, the No Ferry Service Alternative would implement the

same geotechnical stabilization measures that would reduce seismic hazards impacts related to geology and soils to a less-than-significant level.

However, the loss of the ferry service would represent a loss in alternative emergency access to, and egress from, Treasure Island in the event of a major earthquake. As such, the less-than-significant impact related to limited emergency access to and egress from the Islands in the event of a major earthquake, as identified for the Proposed Project (Impact GE.6), would be increased in magnitude under the No Ferry Service Alternative. However, as with the Proposed Project, on-Island emergency police and fire services and back-up utility infrastructure would be available on both islands. Additionally, alternate water access and egress would continue to be available at Pier 1 on the east side of the Treasure Island. For these reasons, the impact of limited emergency access and egress under the No Ferry Service Alternative would be less than significant, and no mitigation is required.

Hydrology and Water Quality

Potential impacts to hydrology and water quality under the No Ferry Service Alternative would be similar to those discussed for the Proposed Project, except of reduced intensity for some impact categories. Development would be reduced under this alternative, which would result in reduced intensity of construction-period disturbances that could affect stormwater quality. Potential water quality effects associated with dredging and installation of facilities into the San Francisco Bay, in support of a ferry terminal, would not occur under this alternative. Other facilities, including the proposed wastewater treatment plant upgrades, water and utility infrastructure, the stormwater treatment wetland, and other facilities installed under the No Ferry Service Alternative would be similar to those indicated for the Proposed Project, although likely sized slightly smaller or lesser in extent, according to reduced load requirements of less development. This alternative would include slightly more open space than the Proposed Project (about 6 more acres), and is therefore, anticipated to have slightly more area of new impervious surfaces as compared to the Proposed Project. The No Ferry Service Alternative would result in implementation of similar measures to minimize hydrologic resources impacts, as compared to the Proposed Project. These would include installation of stormwater BMPs, adherence to water discharge and other permit conditions, and climate change mitigation measures. For these reasons, implementation of the No Ferry Service Alternative would result in similar hydrology and water quality impacts, although reduced in intensity, as compared to the Proposed Project, while those impacts related to ferry service operations would be eliminated entirely. Therefore, as with the Proposed Project, construction-related hydrology and water quality impacts of this alternative would be less-than-significant with implementation of Mitigation Measure M-HZ-1 which requires a SGMP as identified in the Proposed Project.

Hazards and Hazardous Materials

The No Ferry Service Alternative would have potential impacts similar to the Proposed Project related to hazards and hazardous materials, although the overall use, storage and transport of hazardous materials would be reduced. The Navy would continue to be responsible for completing its remediation responsibilities under the requirements of CERCLA and the Petroleum Program. The additional remediation required to support the proposed land uses by the project sponsors also would be the same. As with the Proposed Project, implementation of Mitigation Measures M-HZ-1 and M-HZ-8 would reduce potential exposure to hazardous materials emissions during project construction, and Mitigation Measure M-HZ-13 would reduce potential exposure at the existing Treasure Island School. Therefore, as with the Proposed Project, impacts of the No Ferry Service Alternative on hazards and hazardous materials would be less than significant with implementation of the proposed mitigation measures identified for the Proposed Project.

Mineral and Energy Resources

The No Ferry Service Alternative would include the same types of energy conservation measures as would the Proposed Project. In addition, new renewable energy sources, such as solar photovoltaic panels, would be developed to offset energy demand. This alternative would generate less demand for electricity, natural gas, heating, and cooling on the Islands than under the Proposed Project because fewer people would live and work on the Islands. Like the Proposed Project, the No Ferry Service Alternative would not result in significant environmental impacts associated with mineral and energy resources.

Agricultural Resources and Forest Land

The No Ferry Service Alternative would have the same impacts on agricultural resources as the Proposed Project. Informal harvesting of olives for olive oil would be halted, the 20-acre Urban Agricultural Park would be created, and Islands-created green waste would be composted. Locally-grown food would be created on the Urban Agricultural Park, and there would be new opportunities for agricultural-related training and employment, local business development, and educational programs.

Similarly, natural habitats on Yerba Buena Island would be maintained under a Habitat Management Plan implemented as part of the No Ferry Service Alternative to protect and enhance native habitat. As with the Proposed Project, implementation of a Habitat Management Plan would not result in significant impacts on timberland and could result in improvements to oak woodlands and other natural habitats. Therefore, as with the Proposed Project, impacts to agricultural resources and forest land would be less than significant under the No Ferry Service Alternative.

- **D. REDUCED PARKING ALTERNATIVE**

DESCRIPTION

The Reduced Parking Alternative would reduce the maximum total amount of off-street parking that could be provided on the Islands. The alternative would provide a maximum of 0.5 parking spaces per residential unit, for a total of 4,000 parking spaces available to residents on an Islands-wide basis. It would provide a maximum of 1 parking space per 1,000 sq. ft. of commercial/flex space in Buildings 1, 2, and 3 and for office uses, and a maximum of 0.4 parking spaces per hotel room. Retail parking would continue to be provided at a maximum of 2 spaces per 1,000 sq. ft., as in the Proposed Project. The amount of parking for open space uses and the marina and Sailing Center would also remain as in the Proposed Project. On-street parking, all of which would continue to be metered spaces, would remain at 1,035 spaces because the on-street parking supply is a function of the layout of the street network, which was not assumed to change. On-street parking spaces represent less than 10 percent of the overall supply. Taken together, the reduction in parking ratios for the above listed land uses in the Reduced Parking Alternative

- would reduce the total number of off-street parking spaces by about 4,030, from about 9,646 in the Proposed Project to about 5,616 spaces.

As with the Proposed Project, the parking supply discussed within this section refers to the Islands-wide maximums for individual uses, and as with the Proposed Project, there are no parking minimums for individual uses. Table VII.19: Proposed Parking Supply Ratios and Supply by Land Use, compares, by land use, the amount of parking in the Proposed Project with the Reduced Parking Alternative. The Reduced Parking Alternative's parking supply would be about one-half of that generally required by the City's Planning Code for similar land uses. However, there are some areas of San Francisco, such as Downtown (e.g., the Rincon Hill and South of Market areas), the Eastern Neighborhoods, North Beach, and the Market/Octavia neighborhood, among others, where other public and private on-street and off-street parking facilities supplement parking provided by individual developments; these neighborhoods have parking maximums lower than required generally in other parts of the City. For comparison purposes, Table VII.20 summarizes a variety of different parking requirements from the City's Planning Code, both generally for the City and for neighborhoods with unique requirements. However, it is important to note that supplemental parking facilities would not be permitted on Treasure Island under the proposed *Design for Development*, because the 1:1 residential parking ratio represents an Islands-wide cap, unlike the other San Francisco neighborhoods noted above.

● **Table VII.19: Proposed Parking Supply Ratios and Supply by Land Use**

Land Use	Size	Proposed Project		Reduced Parking Alternative	
		Ratio	Supply	Ratio	Supply
Residential	8,000 d.u.	1 space/d.u. ²	8,000	0.5 space/d.u.	4,000
Hotel (Treasure Island)	450 Rooms	0.4 spaces/room ³	180	0.4 spaces/room	180
Hotel (Yerba Buena Island)	50 Rooms	0.8 spaces/room ³	40	0.4 spaces/room	20
Retail	207,000 square feet	2/1,000 square feet ⁴	414	2/1,000 square feet ⁹	414
Open Space (Athletic Fields)	40 acres	5.1/acre ⁵	204	5.1/acre	204
Open Space (Other)	260 acres	1/acre ⁵	260	1/acre	260
Marina	400 slips	0.59/slip ⁵	236	0.59/slip	236
Flex ¹	202,000 square feet ¹	1/1,000 square feet ⁶	202	1/1,000 square feet	202
Office	100,000 square feet	1/1,000 square feet ⁶	100	1/1,000 square feet	100
Police/Fire	30,000 square feet	None ⁷	N/A	None	N/A
School	105,000 square feet	None ⁷	N/A	None	N/A
Community Center	48,500 square feet	Street parking ⁸	N/A	Street parking	N/A
Cultural Park/Museum	75,000 square feet	Street parking ⁸	<u>N/A</u>	Street parking	<u>N/A</u>
Off-Street Parking Subtotal			9,646		5,616
General On-Street Parking	N/A	N/A	<u>1,035</u>	N/A	<u>1,035</u>
Total			10,681		6,651

Notes:

General note: Land uses where parking rates differ from the Proposed Project are shaded in gray.

¹ Includes 22 ksf food production/industrial/manufacturing, 150 ksf entertainment, and 30 ksf community/office uses.

² Consistent with *San Francisco Planning Code* for neighborhoods in San Francisco without specific and unique requirements except that Treasure Island parking requirements are a maximum and thus, not required, whereas *Planning Code* requirements are a minimum. See Table VII.20 for comparison of parking requirements for various land uses in several districts in San Francisco.

³ Hotel rate is the same as or less than the rate for hotels in Neighborhood Commercial District, *San Francisco Planning Code*.

⁴ Lower than permitted in *San Francisco Planning Code* for comparable neighborhoods, which permits up to 2 spaces per 1,000 square feet and up to 4 spaces per 1,000 square feet above 20,000 square feet. (Retail parking rates were not adjusted between the Proposed Project and the Reduced Parking Alternative, as explained in footnote 9).

⁵ Consistent with *Parking Generation*, Third Edition, Institute of Transportation Engineers. As somewhat unique land uses compared to retail, hotel, housing, and office uses, parking rates for the open space and marina uses were not adjusted from standard rates.

⁶ Consistent with *San Francisco Planning Code* rate for Office uses, although for flex space, in addition to office space, uses could include entertainment and some production, distribution, and repair uses, some of which have higher and some of which have lower parking rates than included in the *San Francisco Planning Code*.

⁷ Parking for police/fire and school facilities expected to be provided separately within the respective sites. Neither parking demand nor supply for these uses is included in this analysis.

⁸ These uses would share from the available pool of 1,035 on-street parking listed under the general on-street parking.

⁹ Although requested by some commenters, the retail rate was not adjusted in the Reduced Parking Alternative because the rate included in the Proposed Project is already 50 percent lower than what is permitted by the *San Francisco Planning Code*. Under both the Proposed Project and the Reduced Parking Alternative, the proposed retail parking rates do represent a reduction from the Planning Code – see footnote 4 above. In addition, parking for retail uses (414 spaces) represents a relatively small percentage (under 4 percent) of the overall supply of parking for the Proposed Project.

Source: TICD, 2009; Fehr & Peers, 2010

● **Table VII.20: San Francisco Off-Street Parking Required or Permitted as Accessory for Select Districts and Uses**

Land Use	Permitted or Required Parking ¹	Parking Permitted with Planning Commission Approval	Parking Maximum
<u>Citywide Parking (except as below)</u>			
Dwelling Units	1 space / unit		
Office ²	2.0 spaces/1,000 square feet		
Retail (<5,000 square feet)	None required		
Retail (between 5,000 and 20,000 square feet)	2.0 spaces/1,000 square feet		
Retail (for each 1,000 square feet in excess of 20,000)	4.0 spaces/1,000 square feet		
Retail devoted to handling bulky merchandise (>5,000 square feet)	1.0 space/1,000 square feet		
Restaurant, bar, nightclub, pool hall, dance hall, bowling alley, or other similar enterprise (>5,000 square feet)	5.0 spaces/1,000 square feet		
<u>Commercial Districts (C-3)</u>			
Dwelling Units	.25 space/unit	.75 space/unit	.75 space/unit
Dwelling Units (with at least 2 bedrooms and at least 1,000 square feet)	.25 space/unit	1.0 space/unit	1.0 space/unit
Non-residential uses	None required		7 Percent of Gross Floor Area
<u>Van Ness and Market DTR Special Use District</u>			
Dwelling Units	.25 space/unit	.50 space/unit	.50 space/unit
<u>Neighborhood Commercial Transit (NCT)</u>			
Dwelling Units	.5 space/unit	.75 space/unit	.75 space/unit
Non-Residential	None required		1.0 space / 1,500 square feet
<u>Residential Transit-Oriented (RTO)</u>			
Dwelling Units	.75 space/unit	1 space/unit	1 space/unit
Non-Residential	None permitted	None permitted	None permitted
<u>Rincon Hill DTR District</u>			
Dwelling Units	.50 space/unit	1.0 space/unit	1.0 space/unit (continued)

● **Table VII.20 (cont.)**

Land Use	Permitted or Required Parking ¹	Parking Permitted with Planning Commission Approval	Parking Maximum
<u>Eastern Neighborhoods: Mixed Use General, Mixed Use Office, and Mixed Use Residential</u>			
Dwelling Units	.25 space/unit	.75 space/unit	.75 space/unit
Dwelling Units (with at least 2 bedrooms and at least 1,000 square feet)	.25 space/unit	1.0 space/unit	1.0 space/unit
Office	None required		7 Percent of Gross Floor Area
Retail (where any portion of the parcel is less than ¼ mile from Market, Mission, Third, and Fourth Streets, except grocery stores >20,000 gross square feet)	1.0 space / 1,500 square feet		1.0 space / 1,500 square feet
<u>Eastern Neighborhoods: Urban Mixed Use</u>			
Dwelling Units	.75 space/unit		.75 space/unit
Dwelling Units (with at least 2 bedrooms and at least 1,000 square feet)	1.0 space/unit		1.0 space/unit
Office	1.0 space/1,000 square feet		1.0 space/1,000 square feet
Office (where the entire parcel is greater than ¼ mile from Market, Mission, Third, or Fourth Streets)	2.0 spaces/1,000 square feet		2.0 spaces/1,000 square feet

Notes:

¹ Parking rates shown for “Citywide” are minimum parking requirements. Parking rates shown for other special districts are parking maximums.

² Section 151 of the Planning Code makes a distinction between several different types of office. The rate presented here is for the “Other Business Office” category and is intended to illustrate the rate that is most commonly applied. Please refer to Planning Code Sections 151 and 151.1 for details or rates for other types of office use.

³ Retail grocery stores with over 20,000 square feet of occupied floor area are permitted 1 space/500 square feet and can receive Planning Commission Authorization for up to 1 space/250 square feet.

Source: San Francisco Planning Code

Land uses would remain the same as in the Proposed Project, except that fewer parking spaces would be permitted to be constructed for residential and hotel uses and less parking would be permitted to be constructed for certain commercial uses. The numbers, types, and sizes of buildings would not change substantially with the alternative; some buildings might have fewer basement levels for parking, and some buildings that might have included above-ground parking wrapped by residential or commercial uses might not include parking. As in the Proposed Project, stand-alone parking garages with no other uses included were not proposed for off-street parking; any above-ground parking garages in residential or mixed-use buildings would be required to be wrapped by active commercial or residential uses, and parking would not be visible

from public rights-of-way.¹³ Also as in the Proposed Project, parking would not be required to be included in buildings; therefore, while more buildings might be constructed with no parking in the Reduced Parking Alternative, some also might be constructed with no parking in the Proposed Project, as there are no parking minimums on either a building or Islands-wide basis.

The Reduced Parking Alternative would provide the same base transit service, with the Muni line 108 - Treasure Island bus service at existing headways, new bus service to the East Bay at approximately 10 minute peak headways, and ferry service to San Francisco at approximately 50 minute headways. Fare-free shuttle service throughout the Islands would be provided and would be available to residents and visitors as described for the Proposed Project. Bicycle and pedestrian networks on the Islands would remain the same as in the Proposed Project. Utilities and infrastructure included in the Proposed Project would be the same in the Reduced Parking Alternative. Geotechnical stabilization would occur in the same manner and in the same locations as in the Proposed Project. The Reduced Parking Alternative would require all of the same approval actions as those listed for the Proposed Project on pp. II.83 – II.84.

The Proposed Project's basic objectives include: a) to implement a land use program with high-density, compact residential and commercial development located within walking distance of an intermodal Transit Hub to maximize walking, bicycling, and use of public transportation and to minimize the use and impacts of private automobiles; b) to provide high-density, mixed-income housing consistent with transit-oriented development; c) to create a circulation and transportation system that emphasizes transit-oriented development, discourages automobile use, and supports and promotes the use of public transportation; d) to create a development that is financially feasible, that allows for the delivery of infrastructure, public benefits, and affordable housing subsidies; and that is able to fund the Proposed Project's capital costs and ongoing operation and maintenance costs relating to the redevelopment and long-term operation of the project site; and e) construct a high-quality development project that is able to attract investment capital and construction financing and produce a reasonable return on investment.

The Reduced Parking Alternative would not meet some of these basic project objectives. In particular, the project sponsors believe that the Reduced Parking Alternative would not "create a development that is financially feasible, that allows for the delivery of infrastructure, public benefits, and affordable housing subsidies; and that is able to fund the Proposed Project's capital costs and ongoing operation and maintenance costs relating to the redevelopment and long-term operation of the project site." In addition, the project sponsors believe that the Reduced Parking

¹³ *Treasure Island + Yerba Buena Island Design For Development*, Draft dated March 5, 2010, Section 6.1.2, p. 204.

Alternative would not result in “a high-quality development project that is able to attract investment capital and construction financing and produce a reasonable return on investment.” The alternative would not “minimize the...impacts of private automobiles” more than would the Proposed Project, as significant traffic impacts identified for the Proposed Project would not be substantially reduced. Therefore the alternative would not be more effective at meeting this basic project objective than would the Proposed Project.

ENVIRONMENTAL ANALYSIS

Transportation

The Reduced Parking Alternative would include the same transportation improvements as the Proposed Project, as described in Section IV.E, Transportation, beginning on p. IV.E.30, with the exception of the reduced parking program as described above. The Reduced Parking Alternative would include the same roadway network as the Proposed Project, and the developed area would be on the same footprint. With the Reduced Parking Alternative, the total number of off-street parking spaces would be up to about 5,615 compared with up to about 9,645 spaces included in the Proposed Project. Both alternatives would include 1,035 on-street parking spaces. All other uses would be the same as those for the Proposed Project.

Methodology

A number of comments requested a Reduced Parking Alternative be analyzed and suggested that such an alternative would likely reduce transportation impacts by reducing automobile trips. This section summarizes the available methodologies for assessing the effects of reduced parking supplies on peak hour vehicle trip generation based on a literature review conducted by the EIR preparers. Additional discussion of the travel demand methodology for the Reduced Parking Alternative is included in the memorandum titled *Supplemental Transportation Analysis for Reduced Parking Alternative Treasure Island/Yerba Buena Island EIR*, February 25, 2011 (“*Supplemental Transportation Analysis memorandum*”).¹⁴

Comments suggested reductions to both residential and non-residential parking supply. As the effects of residential and non-residential parking supply on travel demand are somewhat independent with respect to the Proposed Project, each is discussed separately below.

¹⁴ Fehr & Peers, February 25, 2011, Letter to San Francisco Planning Department, *Supplemental Transportation Analysis for Reduced Parking Alternative: Treasure Island / Yerba Buena Island Redevelopment Plan EIR* (hereinafter cited as “*Supplemental Transportation Analysis memorandum, 2/25/11*”). A copy of this document is available for public review at the San Francisco Planning Department, 1650 Mission Street, Suite 400, in Case File No. 2007.0903E.

Residential Parking Supply

As part of the transportation analysis effort for the Proposed Project, a literature review was conducted on the effects that parking supply has on trip generation (documented in Fehr & Peers letter to Planning Department dated February 15, 2010) to determine whether independent research has established a direct correlation between parking supply and vehicle trip generation. Although reducing parking supplies may be an effective land use strategy, particularly in areas well-served by transit like Downtown or the Market/Octavia area of San Francisco, where public and private on-street and off-street parking facilities supplement parking provided by individual uses, there is inadequate data to accurately predict and quantify reductions in vehicle trip generation associated with the individual effect of reduced parking supply.¹⁵

One of the reports included in the literature review, published by the Transit Cooperative Research Program (“TCRP”), a cooperative effort of the Federal Transit Administration, the Transportation Research Board, and the Transit Development Corporation, Inc., *TCRP Report 128 – Effects of TOD on Housing, Parking, and Travel* (“TCRP Report”),¹⁶ did identify relationships between residential parking supply and peak hour trip generation, although the identified relationships are statistically very weak. In fact, it is precisely because these relationships are very weak that transportation engineers and planners who study them do not commonly use them in forecasting travel demand. Because of the weak linkages in the study, caution should be exercised in using them to make major land use or policy decisions. However, in light of the public comments received on the Draft EIR, the City elected to analyze the potential effects of a reduced parking supply on trip generation based on the data available from the TCRP Report, even though the limitations of that study and generally low confidence in the data are acknowledged.

The equations in the TCRP Report predict some reduction in peak hour vehicle trip generation based on reductions in residential parking supply. Generally, as residential parking supply ratios decrease from 1 space per dwelling unit to 0.5 spaces per dwelling unit, the TCRP Report’s equations predict a vehicle trip reduction for residential uses of 24 percent daily, 30 percent in the AM peak hour, and 16 percent in the PM peak hour. Although the TCRP report does not include data regarding Saturday peak hour travel demand, Fehr & Peers derived relationships and applied the weekday data from the TCRP Report to Saturday peak hour travel demand. The result of this analysis suggests a 10 percent reduction in Saturday peak hour residential travel demand associated with the reduced residential parking.

¹⁵ Supplemental Transportation Analysis memorandum, 2/25/11.

¹⁶ *TCRP Report 128 – Effects of TOD on Housing, Parking, and Travel*; Arrington, G.B., and Cervero, R.; Transportation Research Board, Washington, D.C., 2008). A copy of this report is available for public review at the San Francisco Planning Department, 1650 Mission Street, Suite 400, in Case File No. 2007.0903E.

However, the City does not believe it would be appropriate to rely on the TCRP Report's predictive equations to quantify trip reductions for a number of reasons outlined in the *Supplemental Transportation Analysis* memorandum. Specific reasons described in the memorandum are:

- The relationships are described in the TCRP report itself as “fairly weak;”
- The relationships are derived primarily from areas with parking supplies higher than what is proposed in the Reduced Parking Alternative, which may mean that the TCRP data is not entirely applicable to the Reduced Parking Alternative; and
- The sites that were surveyed to derive the relationships were not consistent with respect to density, land use diversity, and other variables that may have a greater effect on trip generation, which suggests that other factors may be affecting the relationships and not exclusively parking supply.

Thus, for the reasons stated above, the City has concluded that it would not be appropriate to assume that the trip reductions predicted by the TCRP Report's equation would materialize, and therefore, the Reduced Parking Alternative could not be relied upon to reduce traffic impacts. The trip generation assumptions for the Proposed Project included in the EIR already account for many of the more influential factors noted in the TCRP Report, such as the project's density, development scale, diversity of uses, and design of its street network (collectively referred to as the 4D's¹⁷ throughout the EIR).

However, the City also acknowledges that despite the lack of conclusive data demonstrating a link between parking supply and trip generation, it is possible that such a link could exist for the Proposed Project. The Proposed Project is unique in a number of respects from other projects. The Proposed Project is located on two islands and isolated from other peripheral parking lots and garages. The Proposed Project uses an Islands-wide cap on parking supply, rather than the building-by-building parking limits that are more commonly found in parking codes that seek to restrict parking supply. (All of the parking ratios in the current San Francisco Planning Code that are summarized in Table VII.20 are applied on a building-by-building basis.) Together, these factors mean that parking supply restrictions on the Islands may produce different results from those in many downtown San Francisco projects. In downtown San Francisco, for example, individual buildings have limitations on parking supply, but there are other nearby free-standing parking facilities, surface lots, or street parking that can serve the building occupants, allowing some residents who do not have parking in their building to secure parking in another location. This would not be possible on the Islands, as constructing any additional reservoirs of parking exceeding the Islands-wide maximums would not be permitted, no additional parking would be

¹⁷ Refer to the *Transportation Impact Study* in Appendix C of the EIR for additional discussion of the 4Ds.

available on the periphery or in an adjacent neighborhood, and all on-street parking would be priced for short-term usage by both residents and visitors. While the City acknowledges it is possible that the unique conditions of the Proposed Project might make it more likely that the reductions in parking supply would influence vehicle trip generation, the City does not have data to support this conclusion. Further, there are not adequate examples in the United States of neighborhoods located on islands with the mix of land uses, proximity to transit supply, and regional connectivity characteristics similar to the Proposed Project from which additional studies could be performed or data could be obtained.

While the City is not able to rely on trip reductions in its impact analysis, the analysis of the Reduced Parking Alternative includes a discussion as to how the reduced parking supply might affect the travel behavior and resulting impacts discussed in the EIR. The quantification of potential reductions associated with the Reduced Parking Alternative included in the discussion below is not meant to suggest a confident forecast of travel behavior changes that may be expected due to a reduced parking supply, nor does the City intend to use the quantification for the purposes of evaluating travel demand for future projects. Rather, the purpose of the discussion is meant to illustrate how reductions in trip generation might affect the impacts concluded for the Proposed Project, if in fact, they were to materialize, despite limited empirical evidence.

In the absence of other independent, verifiable data, the City relied on the TCRP Report's predicted traffic generation reductions as the basis for this discussion.

Non-Residential Parking Supply

Comments also requested that the Reduced Parking Alternative examine the effects of reduced parking supply for non-residential uses. In response, as discussed earlier in this section, the Reduced Parking Alternative includes reductions to maximum parking supply rates for Flex, Hotel, and Office uses compared to the rates in the Proposed Project. No adjustments to the Retail parking rate are proposed as part of the Reduced Parking Alternative, because unlike other uses, the rate proposed as part of the Proposed Project is already 50 percent lower than the minimum generally required by the *San Francisco Planning Code* for buildings greater than 20,000 square feet. As a result, the Reduced Parking Alternative includes maximum parking supply rates for Residential, Hotel, Retail, Flex, and Office uses that are approximately 50 percent lower than the minimum generally required by the *San Francisco Planning Code*.

As shown in Appendix D2 to the Project's *Transportation Impact Study*, the Flex, Hotel, and Office components of the Proposed Project generate relatively small amounts of vehicle trips,

compared to the Proposed Project as a whole. Combined, these uses generate 15 percent of the project's total vehicle trip generation in the AM peak hour and 11 percent in the PM peak hour. Therefore, even if reductions to parking supplies for these non-residential uses were to result in a reduction in peak hour vehicle trip generation, the overall effect to the number of vehicle trips generated onto and off of the Islands would be relatively small.

However, in response to numerous comments on the subject, the literature review conducted for the Proposed Project also looked for studies that examine the links between non-residential parking supply and vehicle trip generation. No studies were found that identified such links specifically and exclusively for non-residential parking supply. However, a few more comprehensive studies were found that identified the total vehicle trip reductions that have been observed associated with a number of different travel demand management strategies (including parking supply reductions) individually and combined. These studies suggest that there are limits as to how much total vehicle trip reduction can be achieved, and that the Reduced Parking Alternative, including vehicle trip reductions associated with residential parking reductions, would meet or exceed those limits, even without accounting for non-residential parking reductions.

One of the more exhaustive studies on the effectiveness of various strategies at reducing vehicle trip generation was a report prepared by Fehr & Peers for the California Air Pollution Control Officers Association ("CAPCOA"), *Quantifying Greenhouse Gas Mitigation Measures – A Resource for Local Government to Assess Emission Reductions from Greenhouse Gas Mitigation Measures*. The CAPCOA report summarized a number of other studies, including one conducted by Nelson\Nygaard Consulting Associates that specifically discussed the general relationship between parking supply and vehicle trip generation. Although not specific to non-residential parking supply, the Nelson\Nygaard study could be applied to the non-residential uses for purposes of assessing the effects on vehicle trip generation of the Reduced Parking Alternative. The Nelson\Nygaard study developed a model that uses the ITE *Parking Generation* handbook as the baseline figure for parking supply.¹⁸ The Nelson\Nygaard study assumes data in the ITE research to represent unconstrained demand (or, the parking demand in a typical, auto-oriented, suburban setting), since ITE parking rates are based on suburban development and have tended to overestimate the demand for parking in more urbanized areas. However, the literature suggests no reductions to trip generation associated with reductions in parking supply should be taken once

¹⁸ Nelson\Nygaard, 2005. *Crediting Low-Traffic Developments* (p. 16)
<http://www.montgomeryplanning.org/transportation/documents/TripGenerationAnalysisUsingURBEMIS.pdf>

trip generation forecasts are below 50 percent of typical rates as suggested by ITE. That is, once the forecast of trip generation rates has been reduced by 50 percent by virtue of the high-density, mixed-use, or transit-oriented characteristics of the project, as compared to standard ITE trip generation rates, no data supports further reductions beyond 50 percent by virtue of constraining the parking supply available to the project.

In the case of both the Reduced Parking Alternative and the Proposed Project, the reductions already taken to account for the Proposed Project's characteristics (density, diversity of uses, robust transit supply, and reductions to residential parking supply exceed 50 percent of the unadjusted ITE trip generation forecasts. For example, as shown in Table IV.E.4: Person-Trip Generation by Land Use, on p. IV.E.58 of the EIR, in the PM peak hour the combined effect of adjustments made for the projects' density, diversity of uses, etc. (collectively, the 4D's) is 39 percent. As shown on Table IV.E.5: Person-Trip Generation by Mode, on p. IV.E.60 of the EIR, 25 percent of the trips coming to or leaving the Islands would be by transit. This represents 15 percent of total trips (internal and external) generated during the PM peak hour. The combined effect of the 4D's and the reduction associated with transit is 54 percent (39 percent associated with the 4D's and 15 percent associated with transit use). Therefore, since the analysis has already included reductions of more than 50 percent due to other features of the Proposed Project, the data suggests additional trip reductions should not be taken as a result of non-residential parking supply reductions; and, as noted earlier, even if reductions to vehicle trip generation were to materialize, the effect would be relatively small since the affected uses generate a relatively small portion of overall vehicle trips associated with the Proposed Project. In summary, although the Reduced Parking Alternative includes reductions to the parking supply for the flex, hotel, and office uses, no associated reductions were made to the trip generation associated with these uses.

Travel Demand

As described above, the potential changes to trip generation associated with the reduction in parking supply included in the Reduced Parking Alternative have been quantified. Overall, except for the accounting for reduced parking supply as described above, the methodology for assessing travel demand of the Reduced Parking Alternative was the same as that used for the Proposed Project. Table VII.21 summarizes the project travel demand for the Proposed Project and the Reduced Parking Alternative that would occur if the reduction in vehicle trips associated with the reduced parking supply implied by the TCRP Report data presented above were to materialize. The TCRP Report does not quantify whether the reduced automobile trip generation would result from a net decrease in total person-trips or whether all of the trips that would no longer be made by auto would still be made during the peak hours, but via different mode. To be

● **Table VII.21: Person-Trip Generation by Mode – Proposed Project and Reduced Parking Alternative**

Peak hour	Person-Trip Generation ¹				Total Vehicle-Trips ²
	External		Internal		
	Ferry	Bus	Auto	Other ³	
Proposed Project					
AM	641	621	3,391	3,296	1,613
PM	817	898	5,124	4,850	2,462
Saturday	473	595	5,913	5,743	2,861
Reduced Parking Alternative					
AM	948	991	2,714	3,296	1,277
PM	1,003	1,125	4,711	4,850	2,255
Saturday	580	754	5,647	5,743	2,728

Notes:

¹ This analysis assumes no external pedestrian or bicycle trips onto or off of the Islands. With construction of the new east span bicycle/pedestrian path, it is possible that some bicycle trips may occur. However, this number is not likely to affect the overall conclusions of this study. Further, the potential new bicycle facility on the west span of the Bay Bridge is still in the Project Study Report (PSR) phase, and is not assumed to be in place in this analysis.

² Vehicle-trips include passenger vehicles and vans. Refer to EIR for discussion of methodology for calculating net vehicle trip generation increases.

³ Includes internal bicycle and pedestrian trips, and a relatively small number of internal auto trips (e.g., between Yerba Buena Island and Treasure Island).

Source: Fehr & Peers 2010

conservative, this analysis assumes the total person trip-generation would not change; instead there would be a shift from auto use to bus and ferry use, resulting in a decrease in vehicle trips but an increase in transit trips. The allocation of those new transit trips between buses and ferries was done using the same methodology as that of the Proposed Project, based on the type of land use generating the trips (in this case, residential) and the type of trips generated by that land use during the peak hours (50 percent work and 50 percent non-work). In this case, all of the additional peak-hour transit trips were residential, which are more likely to be work trips than the average trip generated by the project. Because work and non-work trips have different propensities to choose buses or ferries, the ferry and bus ridership did not increase proportionally to the ferry and bus ridership of the Proposed Project. The data presented in Table VII.21 are for the same base transit service proposed by the Project, without expanded transit service as proposed in Mitigation Measure M-TR-2¹⁹. Table VII.22 compares the same information under conditions with Mitigation Measure M-TR-2 in place. The percentage reduction in vehicle trips

¹⁹ Mitigation Measure M-TR-2 would increase peak period ferry service from 50 minute frequencies to as much as 15-minute frequencies. It would increase peak period frequencies on the 108-Treasure Island bus route from 15 minutes to between 5 and 7 minutes. It would also create a new bus route to another location in San Francisco, such as the Civic Center area, with frequencies as low as 12-minutes during peak periods. Bus service to the East Bay would not be affected.

● **Table VII.22: Person-Trip Generation by Mode – Proposed Project and Reduced Parking Alternative (With Implementation of Mitigation Measure M-TR-2)**

Peak hour	Person-Trip Generation ¹				Total Vehicle-Trips ²
	External			Internal	
	Ferry	Bus	Auto	Other ³	
Proposed Project (With M-TR-2)					
AM	958	1,075	2,619	3,296	1,228
PM	1,235	1,567	4,175	4,850	1,983
Saturday	718	1,078	5,043	5,743	2,437
Reduced Parking Alternative (With M-TR-2)					
AM	1,186	1,365	2,101	3,296	961
PM	1,369	1,746	3,862	4,850	1,827
Saturday	807	1,223	4,809	5,743	2,319

Notes:

¹ This analysis assumes no external pedestrian or bicycle trips onto or off of the Islands. With construction of the new east span bicycle/pedestrian path, it is possible that some bicycle trips may occur. However, this number is not likely to affect the overall conclusions of this study. Further, the potential new bicycle facility on the west span of the Bay Bridge is still in the Project Study Report (PSR) phase, and is not assumed to be in place in this analysis.

² Vehicle-trips include passenger vehicles and vans. Refer to EIR for discussion of methodology for calculating net vehicle trip generation increases.

³ Includes internal bicycle and pedestrian trips, and a relatively small number of internal auto trips (e.g., between Yerba Buena Island and Treasure Island).

Source: Fehr & Peers 2010

associated with congestion pricing has not been re-analyzed because the change would be very small. Instead, the trip generation forecasts assume the same percentage reduction to total vehicle trip generation associated with congestion pricing for the Proposed Project would apply to the Reduced Parking Alternative.

For conditions without Mitigation Measure M-TR-2, compared to the Proposed Project, there would be 336 fewer vehicle trips during the weekday AM peak hour (a reduction of 21 percent), 207 fewer vehicles during the PM peak hour (a reduction of 8 percent), and 133 fewer vehicle trips during the Saturday peak hour (a reduction of 5 percent). Also, compared to the Proposed Project there would be 677 more person-trips by ferry or bus during the AM peak hour, 413 more ferry/bus trips during the PM peak hour, and 266 more ferry/bus trips during the Saturday peak hour. Although the number of internal trips is expected to be the same between the Proposed Project and the Reduced Parking Alternative, the increased transit ridership in the Reduced Parking Alternative may result in an increased number of bicycle and pedestrian trips on the Islands.

For conditions with Mitigation Measure M-TR-2, compared to the Proposed Project, there would be 312 fewer vehicle trips during the weekday AM peak hour (a reduction of 25 percent), 156 fewer vehicles during the PM peak hour (a reduction of 8 percent), and 118 fewer vehicle trips

during the Saturday peak hour (a reduction of 5 percent). Also, compared to the Proposed Project there would be 518 more person-trips by transit during the AM peak hour, 313 more ferry/bus trips during the PM peak hour, and 234 more ferry/bus trips during the Saturday peak hour.

Construction Impacts

Construction activities associated with the Reduced Parking Alternative would be similar and only somewhat reduced due to the slightly lesser amount of overall construction as compared to the Proposed Project. Mitigation Measure M-TR-1, a Construction Management Program, described in Section IV.E, Transportation, beginning on p. IV.E.69, would minimize the alternative's contribution to construction-related traffic impacts. However, some disruption and increased delays could still occur even with implementation of M-TR-1, and, as with the Proposed Project, construction-related traffic impacts would remain significant and unavoidable (Impact TR-1).²⁰

Operational Impacts

Traffic

During the peak study periods, the Reduced Parking Alternative would reduce peak hour vehicle trips by approximately 336 trips in the AM peak hour (from 1,613 to 1,277), 207 trips in the PM peak hour (from 2,462 to 2,255), and 133 trips in the Saturday peak hour (from 2,861 to 2,728). Because the analysis assumes that these reductions would be to residential trip generation, they would most likely occur in the peak direction of travel during each peak hour, since travel associated with the Proposed Project would be highly influenced by the residential component.

The EIR included an analysis of the traffic impacts of the Reduced Development Alternative. The person trip generation under the Reduced Development Alternative and under the Reduced Parking Alternative is summarized in Table VII.23, below. As this table shows, the vehicle trip generation for the Reduced Parking Alternative is predicted to be very similar to that of the Reduced Development Alternative, described in Chapter VII, Alternatives as Alternative B, Reduced Development Alternative, beginning on EIR p. VI.15. Further analysis was performed to confirm that the overall geographic distribution of these vehicle trips would also be very similar.²¹

²⁰ The identification of an impact number (i.e., Impact TR-1) refers to the enumeration of impacts in the EIR associated with the Proposed Project. It is provided to facilitate the comparison of impacts of the Reduced Parking Alternative to the Proposed Project. However, the traffic impacts of the Reduced Parking Alternative would be most similar to the impacts of the Reduced Development Alternative.

²¹ *Supplemental Transportation Analysis* memorandum, 2/25/11.

● **Table VII.23: Person-Trip Generation by Mode – Reduced Development Alternative and Reduced Parking Alternative (Without Implementation of M-TR-2)**

Peak hour	Person-Trip Generation ¹				Vehicle-Trips ²
	External		Internal		
	Ferry	Bus	Auto	Other ³	
Reduced Development Alternative					
AM	522	486	2,748	2,745	1,294
PM	696	766	4,652	4,240	2,218
Saturday	426	527	5,321	5,164	2,565
Reduced Parking Alternative					
AM	948	991	2,714	3,296	1,277
PM	1,003	1,125	4,711	4,850	2,255
Saturday	580	754	5,647	5,743	2,728

Notes:

¹ This analysis assumes no external pedestrian or bicycle trips onto or off of the Islands. With construction of the new east span bicycle/pedestrian path, it is possible that some bicycle trips may occur. However, this number is not likely to affect the overall conclusions of this study. Further, the potential new bicycle facility on the west span of the Bay Bridge is still in the Project Study Report (PSR) phase, and is not assumed to be in place in this analysis.

² Vehicle-trips include passenger vehicles and vans. Refer to EIR for discussion of methodology for calculating net vehicle trip generation increases.

³ Includes internal bicycle and pedestrian trips, and a relatively small number of internal auto trips (e.g., between Yerba Buena Island and Treasure Island).

Source: Fehr & Peers 2010

Due to the similarity in vehicle trip generation between the Reduced Development Alternative and the Reduced Parking Alternative, it is possible to use the traffic impact analysis from the Reduced Development Alternative to understand the possible impacts for the Reduced Parking Alternative. Accordingly, if the trip reductions associated with the Reduced Parking Alternative were to materialize, traffic impacts would be nearly identical to those described in the Reduced Development Alternative. Thus, for comparison purposes, the discussion below summarizes the results of the transportation impact analysis conducted for the Reduced Development Alternative, as presented on pp. VII.20 – VII.33, above.

The Reduced Parking Alternative could result in similar significant and unavoidable impacts related to extensive queues and vehicle delays as the Reduced Development Alternative (summarized in Tables VII.4: Ramp Junction Analysis – Existing, Existing plus Proposed Project, and Existing plus Reduced Development Alternative, and Table VII.5: Maximum On-Ramp Queues and Average Delays – Existing plus Project and Existing plus Reduced Development Alternative Conditions, on pp. VII.23 and VII.24), at the following study ramp locations:

- At the eastbound off-ramp on the west side of Yerba Buena Island during the PM peak hour (Impact TR-2);

- Under conditions without the Ramps Project, at the two westbound on-ramps during the AM, PM and Saturday peak hours (Impact TR-3); and
- Under conditions with the Ramps Project, at the ramp meter at the westbound on-ramp on the east side of Yerba Buena Island during the AM and PM peak hours (Impact TR-4).

Similar to both the Proposed Project and the Reduced Development Alternative, under conditions without and with the Ramps Project, the Reduced Parking Alternative would result in less-than-significant impacts at the eastbound on-ramp and eastbound off-ramp on the east side of Yerba Buena Island, and the westbound off-ramp on the east side of Yerba Buena Island (Impact TR-5). Similarly, under conditions without and with the Ramps Project, the Reduced Parking Alternative would also result in a significant impact on queuing at the Bay Bridge toll plaza during the weekday AM peak hour (Impact TR-6), and on San Francisco streets approaching the Bay Bridge during the PM peak hour (Impact TR-7).

Table VII.6: Intersection Levels of Service – Existing and 2030 Cumulative Conditions, on pp. VII.25 – VII.26, presents the comparison of intersection Levels of Service (“LOS”) for Existing plus Project and Existing plus Reduced Development Alternative conditions. Since the Reduced Parking Alternative would be nearly identical to the Reduced Development Alternative in terms of traffic impacts, similar to the Reduced Development Alternative, the Reduced Parking Alternative would result in significant impacts at eight study intersections (compared with nine for the Proposed Project).²²

- Similar to the Reduced Development Alternative, the Reduced Parking Alternative would result in project-specific impacts at six signalized study intersections that operate at LOS D or better under Existing conditions and would deteriorate to LOS E or LOS F under Existing plus Project conditions, or that operate at LOS E under Existing conditions and would deteriorate to LOS F under Existing plus Project conditions (First/Market, First/Mission, First/Folsom, First/Harrison/I-80 Eastbound On-Ramp, Bryant/Fifth/I-80 Eastbound On-Ramp, Fifth/Harrison/I-80 Westbound Off-Ramp) (Impacts TR-8 through TR-13).
- Similar to the Reduced Development Alternative, the Reduced Parking Alternative would have less-than-significant contributions at four signalized study intersections that operate at LOS E or LOS F under Existing conditions and that would continue to operate at LOS E or LOS F under Existing plus Project conditions (First/Howard, Essex/Harrison/I-80 Eastbound On-Ramp, The Embarcadero/Harrison, and Second/Folsom) (Impacts TR-14 and TR-15).
- Similar to the Reduced Development Alternative, the Reduced Parking Alternative would have less-than-significant contributions at five signalized study intersections that would operate at LOS D or better under Existing plus Project conditions (Impact TR-16).

²² The project-specific impact at Second/Folsom would be less-than-significant under the Reduced Development Alternative and, therefore, under the Reduced Parking Alternative.

- Similar to the Reduced Development Alternative, the Reduced Parking Alternative would contribute considerably to two uncontrolled study intersections that operate poorly under Existing conditions, resulting in a project-specific impact (Folsom/Essex and Bryant/Sterling) (Impacts TR-17 and TR-18).

As with the Proposed Project and the Reduced Development Alternative, the traffic impacts at ramps and intersections would be minimized but not eliminated with implementation of Mitigation Measure M-TR-2 (Expanded Transit Service) as discussed in Section IV.E, Transportation, pp. IV.E.74 – IV.E.75. This mitigation measure would reduce vehicle trip generation and would reinforce the proposed TDM practices included as part of the Reduced Parking Alternative, including ramp metering, congestion pricing, etc. As with the Proposed Project and the Reduced Development Alternative, because of uncertainties regarding sources for full funding to implement M-TR-2, its feasibility is uncertain and the impacts that could be mitigated by implementation of M-TR-2 are assumed to remain significant and unavoidable. Aside from increasing the availability of transit service, as proposed by Mitigation Measure M-TR-2, there do not appear to be other proven and/or feasible techniques that are not already part of the Proposed Project that would achieve a substantial increase in transit ridership.

In sum, the Reduced Parking Alternative could potentially have traffic impacts similar to the Reduced Development Alternative, which would be similar to those of the Proposed Project except for one intersection, Second/Folsom (Impact TR-14). That intersection would experience a significant and unavoidable impact with mitigation under the Proposed Project, but the impact could be less-than-significant without mitigation under the Reduced Development Alternative and the Reduced Parking Alternative. However, as noted above, the City has very low confidence in the predictions of the TCRP data, and because of the uncertainty in the estimates, the City cannot reliably conclude that reductions in impacts would occur.

Transit Impacts

The Reduced Parking Alternative transit conditions assume implementation of Project-related transit improvements as described in Section IV.E., Transportation, p. IV.E.94. If travel demand characteristics of the Reduced Parking Alternative shown in Table VII.23 were to materialize, transit ridership in the Reduced Parking Alternative would exceed what was projected for the Proposed Project. Table VII.24 presents the transit ridership and capacity utilization information for the Reduced Parking Alternative (with the base level of transit). As shown in Table VII.24, similar to the Proposed Project, the Reduced Parking Alternative would have a significant impact on transit capacity for Muni service between the Islands and San Francisco because Muni's transit capacity utilization standard of 85 percent would be exceeded. This was also identified as a

● **Table VII.24: Transit Ridership and Capacity Utilization – Existing plus Project and Existing plus Reduced Parking Alternative (Prior to Implementation of M-TR-2)**

Route	Existing plus Project			Existing plus Reduced Parking Alternative		
	Capacity	Rider-ship	% Utilization ¹	Capacity	Rider-ship	% Utilization ¹
<i>AM Peak Hour</i>						
AC Transit EB ²	324	107	33%	324	155	48%
AC Transit WB ²	324	67	21%	324	97	30%
Muni EB Bus Service from SF ³	252	261	104%	252	367	146%
Muni WB Bus Service to SF ³	252	384	152%	252	571	227%
Ferry EB 4	839	238	28%	839	352	42%
Ferry WB 4	839	403	48%	839	596	71%
<i>PM Peak Hour</i>						
AC Transit EB	324	96	30%	324	116	36%
AC Transit WB	324	134	41%	324	162	50%
Muni EB Bus Service from SF	252	515	204%	252	612	243%
Muni WB Bus Service to SF	252	431	171%	252	513	203%
Ferry EB	839	479	57%	839	584	70%
Ferry WB	839	343	41%	839	419	50%
<i>Saturday Peak Hour</i>						
AC Transit EB	324	79	24%	324	94	39%
AC Transit WB	324	90	28%	324	108	33%
Muni EB Bus Service from SF	189	328	174%	189	391	207%
Muni WB Bus Service to SF	189	320	169%	189	383	203%
Ferry EB	839	221	26%	839	271	32%
Ferry WB	839	252	30%	839	309	37%

Notes:

N/A = Not Applicable

¹ **Bold** indicates capacity utilization exceeds the 85 percent capacity utilization standard for Muni line 108-Treasure Island, and the 100 percent capacity utilization standard for new ferry and AC Transit service. Exceedance of the capacity utilization standard is considered a significant impact. Implementation of Mitigation Measure M-TR-2 would result in adequate transit capacity reducing the impacts to less than significant levels.

² New AC Transit bus service between the Islands and downtown Oakland at 10-minute peak headways.

³ Muni line 108-Treasure Island service at 15-minute headways during peak periods.

⁴ New ferry service between Treasure Island and San Francisco at 50-minute peak headways.

Source: Fehr & Peers 2010

significant impact associated with the Proposed Project (Impact TR-19, p. IV.E.95). However, the impact would be exacerbated with the Reduced Parking Alternative, since transit demand would increase. Similar to the Proposed Project, implementation of Mitigation Measure M-TR-2 would increase transit capacity and ridership; however, the capacity increases would be far greater than the ridership increases, and with implementation of Mitigation Measure M-TR-2, the capacity would be adequate to serve projected demand. However, as explained in Section IV.E, Transportation, implementation of M-TR-2 is uncertain, and therefore, the impacts to Muni capacity utilization would remain significant and unavoidable.

Similar to the Proposed Project, impacts on the new AC Transit bus service and ferry serving the Islands, and impacts on other AC Transit, BART, Golden Gate Transit, SamTrans and other ferry lines would be less than significant (Impacts TR-20, TR-21, and TR-23). As presented in Table IV.E.18 on p. IV.E.98, the Muni downtown San Francisco screenlines are not expected to operate near their capacity utilization threshold of 85 percent under conditions with the Proposed Project. The additional transit riders that would occur with the Reduced Parking Alternative would not be enough to cause the downtown screenlines to exceed capacity utilization thresholds and therefore, the Reduced Parking Alternative's impacts to the downtown screenlines would be less than significant (Impact TR-22).

As with the Proposed Project and Reduced Development Alternative, some transit impacts would result from increased traffic congestion at the approaches to the Bay Bridge on-ramps at Yerba Buena Island (Impacts TR-24, TR-25, TR-26, and TR-27). As noted earlier, if reductions in vehicle trip generation associated with the Reduced Parking Alternative were to materialize, traffic impacts would be nearly identical to the Reduced Development Alternative. Thus, similar to the Proposed Project and the Reduced Development Alternative, under conditions with and without the Ramps Project, vehicle queues extending from the Bay Bridge on-ramps at Yerba Buena Island may impact Muni line 108-Treasure Island and AC Transit bus operations during the AM, PM and Saturday peak hours, causing delays to bus service. With implementation of Mitigation Measure M-TR-24 (Transit and Emergency Vehicle Only Lane) described in Section IV.E, Transportation, on p. IV.E.100, the impact on Muni operations would be reduced to a less-than-significant level (Impacts TR-24 and TR-26). Implementation of Mitigation Measure M-TR-24 would improve operations for AC Transit buses destined for the eastbound on-ramp. However, because this improvement would extend only to the transit and emergency vehicle-only westbound on-ramp on the west side of Yerba Buena Island, and because sufficient right-of-way is not available to extend a transit-only lane beyond the transit and emergency vehicle-only westbound on-ramp, AC Transit vehicles would continue to experience congestion between the

transit and emergency vehicle-only westbound on-ramp and the eastbound on-ramp. Therefore, similar to the Proposed Project and the Reduced Development Alternative, the impact on AC Transit operations would remain significant and unavoidable (Impacts TR-25 and TR-27).

Similar to the Proposed Project, implementation of the Reduced Parking Alternative would result in less-than-significant impacts to the existing and proposed ferry services on the San Francisco Bay (Impact TR-28).

As with the Proposed Project and the Reduced Development Alternative, transit impacts would occur from traffic congestion delay in downtown San Francisco with the Reduced Parking Alternative. The transit delay conditions with the Reduced Parking Alternative would affect the same lines as the Proposed Project and the Reduced Development Alternative (27-Bryant, 30X-Marina Express, and 47-Van Ness), resulting in significant and unavoidable impacts (Impacts TR-29 through TR-31). As with the Proposed Project and the Reduced Development Alternative, the Reduced Parking Alternative would not adversely affect operations of Golden Gate Transit or SamTrans bus lines (Impact TR-32).

Implementation of Mitigation Measure M-TR-2 would reduce, but not eliminate, traffic impacts at the study intersections, and therefore, the transit delay impacts of the Reduced Parking Alternative on the Muni lines would remain significant and unavoidable.

In summary, the Reduced Parking Alternative would have the same number of significant transit-related impacts as the Proposed Project, although the severity of the impacts may be somewhat different. If automobile trip generation reductions associated with reduced parking supply were to materialize, the significant impacts due to transit ridership increases would be more severe than the Proposed Project and the significant impacts due to traffic congestion would be less severe than the Proposed Project (and comparable to those of the Reduced Development Alternative). However, as noted earlier in the discussion of traffic impacts, the City has very low confidence in the predictions of the TCRP data, and because of the uncertainty in the estimates, the City cannot reliably conclude that differences in the severity of impacts would occur.

Bicycles

The Reduced Parking Alternative bicycle trips would be accommodated within the proposed street network on the Islands and on mainland San Francisco, and similar to the Proposed Project, impacts related to bicycle accessibility would be less than significant, and no mitigation measures are required (Impacts TR-33 and TR-34). Also, as with the Proposed Project, implementation of Mitigation Measure M-TR-24 would result in the removal of the proposed bicycle lane on a portion of Treasure Island and Hillcrest Roads to accommodate a transit-only lane (Mitigation Measure M-TR-24 would only be implemented if queues on Treasure Island Road materialize

and substantially affect transit operations); however, cyclists would continue to have a continuous Class I shared bicycle and pedestrian facility connecting Treasure Island and the Class I shared bicycle and pedestrian facility currently under construction on the Bay Bridge east span, from the intermodal transit hub to Treasure Island Road across the causeway and continuing along Macalla Road on Yerba Buena Island.

As discussed in the methodology section above and presented in Table VII.20, the analysis assumes that the reduction in vehicle traffic would manifest itself entirely in a mode shift to transit. It is possible that a small portion of the mode shift would be to bicycle instead of to transit; however, given the lack of a bicycle connection to San Francisco, the only travelers this mode shift would affect would be those traveling between the Proposed Project and the East Bay. Further, it is likely that an increase in bicycling would not be so substantial as to affect the analysis of other modes.

Pedestrians

The pedestrian network and improvements would not change materially between the Proposed Project and the Reduced Parking Alternative. Generally, similar to the Proposed Project, the pedestrian environment would be improved compared to existing conditions. As such, the Reduced Parking Alternative would not create potentially hazardous conditions for pedestrians (Impact TR-35). Although the data is uncertain, if the travel characteristics of the Reduced Parking Alternative materialized as summarized in Table VII.21, the Reduced Parking Alternative would result in more pedestrian trips near the Ferry Building in San Francisco than the Proposed Project because there would be increased ferry ridership.

Further, the increased transit ridership may result in an increase in bicycle and pedestrian trips on the Islands. However, the on-island bicycle and pedestrian circulation network would remain adequate to serve expected demands.

Compared to the Proposed Project, the Reduced Parking Alternative would result in 307 more ferry trips during the AM peak hour, 181 more ferry trips during the PM peak hour, and 107 more ferry trips during the Saturday peak hour. With implementation of Mitigation Measure M-TR-2 there would be even more pedestrian trips since the increased transit service would attract more riders.

As shown in Table VII.25, these pedestrians would be accommodated at the crosswalks in the vicinity of the Ferry Building, most of which were projected to operate at LOS C or better under the Proposed Project. Under the Reduced Parking Alternative, the crosswalk at Market Street across from the Ferry Building is projected to operate at LOS D, which is still considered acceptable. Therefore, impacts related to pedestrians would be less than significant, and no mitigation measures are required (Impact TR-36).

● **Table VII.25: Pedestrian Crosswalk Levels of Service – Existing plus Project and Existing plus Reduced Parking Alternative**

Crosswalk ¹	Existing plus Project			Existing plus Reduced Parking Alternative		
	Project Trips	Density ³	LOS	Project Trips	Density ³	LOS
<i>AM Peak Hour</i>						
Washington Street ¹	26	27.4	A	39	25.2	A
Ferry Bldg (North)	87	6.6	C	129	6.1	C
Market Street	427	6.7	C	631	6.2	C
Don Chee Way	29	17.3	A	43	15.9	A
Mission Street ¹	72	9.9	C	107	9.1	C
<i>PM Peak Hour</i>						
Washington Street ¹	46	13.0	A	57	12.6	B
Ferry Bldg (North)	67	7.2	C	82	7.0	C
Market Street	614	3.9	D	749	3.8	D
Don Chee Way	33	12.9	B	40	12.5	B
Mission Street ¹	61	9.9	C	75	9.5	C
<i>Saturday Peak Hour²</i>						
Market Street	334	4.0	D	410	3.9	D
Don Chee Way	28	6.9	C	34	6.8	C

Notes:

¹ Since the intersections of The Embarcadero with Washington Street and Mission Street each have two crosswalks, the north and south legs of each intersection were averaged.

² The Ferry Building hosts a farmers market on Saturdays.

³ Density measured in square feet per pedestrian

Source: Fehr & Peers 2011

Loading

Similar to the Proposed Project, development associated with the Reduced Parking Alternative would be subject to the freight loading space requirements to accommodate the loading demand, and would be designed to minimize impacts on autos, transit, bicyclists and pedestrians and to ensure that loading activities do not result in hazardous conditions. The Reduced Parking Alternative impacts related to loading operations would be less than significant, and no mitigation measures are required (Impact TR-37).

Emergency Access

The Reduced Parking Alternative impacts on emergency access would be the same as for the Proposed Project. Local police and fire facilities would provide first response to incidents on the Islands, and existing emergency routes would be maintained in their existing locations or rerouted as necessary. Similar to the Proposed Project, impacts to emergency access would be less than significant and no mitigation measures are required (Impact TR-38).

Cumulative Conditions

The Reduced Parking Alternative would result in similar construction activities to that of the Proposed Project. As with the Proposed Project, given the overall magnitude of development, the project's prolonged construction period, and the lack of certainty of timing of other construction projects on the Islands, the Reduced Parking Alternative would also result in significant contributions to cumulative construction-related traffic impacts (Impact TR-39).

Overall, if vehicle trip generation reductions associated with the Reduced Parking Alternative were to materialize as described in this section, 2030 Cumulative Conditions traffic operational impacts would be nearly identical to those described for the Reduced Development Alternative. In those circumstances, under 2030 Cumulative conditions, as with the Proposed Project and the Reduced Development Alternative, the Reduced Parking Alternative would contribute to significant cumulative traffic impacts at the following locations:

- At the eastbound off-ramp on the west side of Yerba Buena Island (Impact TR-40);
- Under conditions without the Ramps Project, at the two westbound on-ramps (Impact TR-41); and
- Under conditions with the Ramps Project, at the ramp meter at the westbound on-ramp at the east side of Yerba Buena Island (Impact TR-42).

Similar to the Proposed Project and the Reduced Development Alternative, the Reduced Parking Alternative would result in less-than-significant impacts at the eastbound on-ramp and eastbound off-ramp on the east side of Yerba Buena Island, and the westbound off-ramp on the east side of Yerba Buena Island (Impact TR-43).

Similar to the Proposed Project and the Reduced Development Alternative, the Reduced Parking Alternative would also result in a significant impact on queuing at the Bay Bridge toll plaza during the weekday AM and PM peak hours, and on San Francisco streets approaching the Bay Bridge during the weekday AM and PM and Saturday peak hours (Impacts TR-44 and TR-45).

Table VII.6, on pp. VII.25 – VII.26, includes the comparison of intersection LOS for 2030 Cumulative plus Proposed Project and 2030 Cumulative plus Reduced Development Alternative conditions. The Reduced Parking Alternative would be nearly identical to the Reduced Development Alternative in terms of vehicular trip generation and therefore, would result in the same significant impacts at study intersections as the Reduced Development Alternative and the Proposed Project. Although the Reduced Development Alternative had one fewer project-related impacts than the Proposed Project, the Reduced Development Alternative, and therefore the Reduced Parking Alternative, would have the same number of cumulative impacts as the Proposed Project.

- Similar to the Reduced Development Alternative and the Proposed Project, the Reduced Parking Alternative would result in project-specific impacts at six signalized study intersections that operate at LOS D or better under Existing conditions and would deteriorate to LOS E or LOS F under Existing plus Project conditions, or that operate at LOS E under Existing conditions and would deteriorate to LOS F under Existing plus Project conditions. Because the Reduced Parking Alternative would result in significant project-related impacts at these intersections, it would also result in cumulative impacts at these six intersections (First/Market, First/Mission, First/Folsom, First/Harrison/I-80 Eastbound On-Ramp, Bryant/Fifth/I-80 Eastbound On-Ramp, Fifth/Harrison/I-80 Westbound Off-Ramp) (Impacts TR-46 through TR-51).
- Similar to the Reduced Development Alternative and the Proposed Project, the Reduced Parking Alternative would contribute considerably to critical movements at one study intersection that would operate at LOS E or LOS F under 2030 Cumulative plus Reduced Parking Alternative conditions, resulting in a project impact (Second/Folsom). (Impact TR-52)
- Similar to the Reduced Development Alternative and the Proposed Project, the Reduced Parking Alternative would have less-than-significant contributions at seven study intersections that would operate at LOS E or LOS F under 2030 Cumulative No Project conditions (Fremont/Howard, Fremont/Folsom, Fremont/I-80 Westbound Off-Ramp/Harrison, First/Howard, Essex/Harrison/I-80 Eastbound On-Ramp, Second/Bryant, and The Embarcadero/Harrison). (Impact TR-53).
- Similar to the Reduced Development Alternative and the Proposed Project, the Reduced Parking Alternative would contribute considerably to significant cumulative impacts at two uncontrolled study intersections (Folsom/Essex and Bryant/Sterling) (Impacts TR-54 and TR-55).

As with the Proposed Project and the Reduced Development Alternative, the Reduced Parking Alternative's contribution to cumulative traffic impacts at ramps and intersections would be lessened, but not eliminated, with implementation of Mitigation Measure M-TR-2.

Under 2030 Cumulative conditions, implementation of the Reduced Parking Alternative would have transit impacts similar to those of the Proposed Project, although transit ridership would be higher than under conditions with the Proposed Project. Similar to the Proposed Project, ridership under this alternative would also exceed the capacity of the Muni screenline between the Islands and Downtown San Francisco. Impacts to this screenline would be the same as identified for Existing plus Reduced Parking Alternative conditions, and summarized in Table VII.21. The Reduced Parking Alternative would also add more transit trips to the standard Muni downtown San Francisco screenlines than the Proposed Project; however, the increase is not expected to be severe enough such that ridership demand would exceed capacity, and cumulative impacts on the standard downtown San Francisco screenlines would be less than significant (Impact TR-56). The Reduced Parking Alternative's contributions to cumulative transit trips on AC Transit, BART, Golden Gate Transit, SamTrans, Caltrain, and other ferry routes would not increase demand in excess of available capacity (Impact TR-57). Transit impacts would result from traffic congestion delay in downtown San Francisco and would affect the same lines as the Proposed Project and Reduced Development Alternative would (10-Townsend, 27-Bryant, 30X-Marina Express, and 47-Van Ness) (Impacts TR-58 through TR-61). While implementation of Mitigation Measure M-TR-2 (Expanded Transit Service) would somewhat reduce delays at the downtown study intersections, the impact on transit would remain significant and unavoidable. Increased traffic congestion delay in downtown San Francisco would not affect operations of Golden Gate Transit or SamTrans bus lines (Impact TR-62).

Parking Information

Similar to the Proposed Project, development associated with the Reduced Parking Alternative would be subject to parking space maximums; however, those maximums would be substantially lower than the Proposed Project. As summarized in Table VII.19, the Reduced Parking Alternative would include 6,651 parking spaces, including 4,000 off-street spaces for residential uses, 1,616 off-street spaces for non-residential uses, and 1,035 on-street parking spaces. If travel behavior materialized as summarized in Table VII.21, although the overall demand for spaces would be less than the Proposed Project, parking shortfalls associated with the Reduced Parking Alternative would likely exceed those projected for the Proposed Project.²³

As with the Proposed Project, implementation of the reduced parking supply maximums would result in secondary physical impacts caused by increased traffic congestion and a mode shift to

²³ Since parking supply is reduced for residential units by 50 percent, there would also have to be a reduction in residential trip generation of 50 percent to maintain the same parking shortfall. Since trip generation is not expected to decrease by as much as the parking supply is decreasing, the shortfall under the Reduced Parking Alternative would be greater than under the Proposed Project.

transit that would exacerbate the degree to which capacity utilization standards were exceeded on Muni line 108-Treasure Island. As with the Proposed Project, impacts on the transit capacity utilization would be less than significant with implementation of Mitigation Measure M-TR-2. However, because implementation of Mitigation Measure M-TR-2 is uncertain, impacts would remain significant and unavoidable.

Aesthetics

Off-street parking facilities constructed in mixed-use or residential buildings as part of development in the Reduced Parking Alternative would continue to be wrapped by residential or commercial uses and not be readily visible from public rights-of-way, as with the Proposed Project. Land uses would be the same as the Proposed Project, and heights and densities would also be the same. The numbers, types, and sizes of buildings would not change substantially with the alternative. Therefore, the visual impacts identified for the Proposed Project in Section IV.B, Aesthetics, would not change with the Reduced Parking Alternative.

Noise

As discussed under “Transportation” above, the City has very low confidence that traffic would be substantially reduced if less parking were provided on the Islands. If there were a reduction in vehicle trips as a result of reducing the amount of parking provided, there would be a slight reduction in traffic noise compared to operational traffic noise levels estimated for the Proposed Project in Section IV.F, Noise, in Impact NO-3. The reduction in daily vehicle traffic would not be more than approximately 10 percent. A reduction in traffic volumes of about 10 percent would not reduce the significant noise impacts identified in Impact NO-3 to less-than-significant levels, because the change in noise levels would continue to be 5 dBA or greater (see Table IV.F.6 on p. IV.F.23). Other operational noise impacts would remain the same as those identified for the Proposed Project. Construction noise impacts would not change with the Reduced Parking Alternative, and would remain significant and unavoidable. Mitigation measures identified for the Proposed Project would be applicable to the Reduced Parking Alternative.

Air Quality

As discussed under “Transportation,” the City has very low confidence that traffic would be substantially reduced if less parking were provided. If there were a reduction in vehicle trips as a result of reducing the amount of parking available, there would be a slight reduction in emissions of criteria pollutants compared to emissions from motor vehicles in the Proposed Project. Reducing motor vehicle emissions by approximately 10 percent would not reduce any of the

significant air quality impacts identified in Impact AQ-5 and shown in Table IV.G.5 on p. IV.G.41, as the emissions from other sources would continue to be the same as for the Proposed Project. A reduction of over 50 percent in motor vehicle emissions would be required to reduce the significant impacts of PM 2.5 emissions to less-than-significant levels, and substantially greater reductions in motor vehicle emissions would be necessary to reduce the other significant air quality impacts to less-than-significant levels. A reduction of 50 percent in motor vehicle emissions would not be achieved under the Reduced Parking Alternative. The possible reduction in vehicle trips with reduced parking would not substantially change the amount of diesel particulate emissions, as few of the trips removed would be in diesel-fueled vehicles. Construction air emissions would not change substantially with the Reduced Parking Alternative. Therefore, the air quality impacts identified as significant and unavoidable in the analysis of the Proposed Project would continue to be significant and unavoidable with the Reduced Parking Alternative, and mitigation measures identified for the Proposed Project would be applicable to the Reduced Parking Alternative.

Greenhouse Gases

As described for noise and air emissions, greenhouse gas (“GHG”) emissions might be reduced somewhat with the Reduced Parking Alternative if the alternative were to result in reductions in vehicle trips. Motor vehicle emissions are the largest single source of CO₂e during operation of the Proposed Project (see Tables IV.H.3 and IV.H.4 on pp. IV.H.36 and IV.H.37); however, reductions of 10 percent in motor vehicle emissions would not make a substantial difference in the overall amount of annual CO₂e emissions and therefore would not substantially change the emissions per year per service population presented on p. IV.H.45. The Proposed Project would have a less-than-significant impact on GHG emission, as discussed in Impact GHG-1 on pp. IV.H.44 and IV.H.45. Therefore the Reduced Parking Alternative, if it were to result in fewer vehicle trips, would not cause a significant impact to be reduced to less-than-significant levels.

Other Topics

The Reduced Parking Alternative would have essentially the same impacts as the Proposed Project in the areas of Land Use, Population and Housing, Cultural Resources, Wind and Shadow, Recreation, Utilities, Public Services, Biological Resources, Geology and Soils, Hydrology and Water Quality, Hazards and Hazardous Materials, Agricultural Resources, and Minerals and Energy Resources. Any mitigation measures identified in the subsections of Chapter IV covering these topics would be applicable to the Reduced Parking Alternative.

Conclusion

Overall, the Reduced Parking Alternative would have the same significant impacts as those identified for the Proposed Project except for a possible reduction in one significant traffic impact from significant and unavoidable with mitigation to less-than-significant. In addition, the project sponsors believe that the reduction in parking would undermine the market acceptance of the alternative, yielding a reduced rate of return that is commercially infeasible and a reduction in funding available to support transit services that make this alternative infeasible.

- **E. ALTERNATIVES CONSIDERED BUT REJECTED**

- This section discusses four alternatives that were considered by the project sponsors, but are not analyzed further in this Chapter of the EIR because they either would not achieve most of the project sponsors' objectives, would not reduce significant environmental project impacts, would result in greater impacts than the Proposed Project, and/or do not represent feasible alternatives for other economic, social or environmental reasons. These considered and rejected alternatives include the No Public Trust Exchange Agreement and the Maximum Development Alternative proposed in the *2005 Transfer and Reuse of Naval Station Treasure Island Final EIR*. An off-site location and an alternative including measures to reduce automobile ownership are also briefly discussed.

- **E.1 NO PUBLIC TRUST EXCHANGE AGREEMENT**

All of Treasure Island, including the 367 acres included within the proposed Development Plan Area, would be subject to the Tidelands Trust upon transfer out of federal ownership, from the Navy to TIDA. The Tidelands Trust generally prohibits residential, general office, non-maritime industrial, and certain recreational uses on lands that are subject to the Trust.²⁴ State legislation adopted in 2004 and amended in 2007 and 2009 authorize the State Lands Commission to approve an exchange of Trust-restricted land on Treasure Island to certain non-Trust-restricted lands on Yerba Buena Island proposed for Trust-compatible uses in the Proposed Project. TIDA considered an alternative Development Program that would not require a Public Trust Exchange Agreement (“Agreement”). The purpose of this alternative was to determine whether the project sponsors' objectives could be achieved without execution of the Agreement.

Without the Agreement, Tidelands Trust restrictions would not be lifted from the portions of Treasure Island that are planned for residential and other non-Trust uses and transferred to portions of Yerba Buena Island that currently are not subject to the Tidelands Trust (see Chapter II, Project Description, Figure II.3, Tidelands Trust Land Exchange, p. II.15). In this alternative, the 367 acres of land on Treasure Island transferred to TIDA by the Navy would remain subject to the Tidelands Trust,²⁵ and there would be no exchange of Trust land from Treasure Island to certain non-Trust-restricted lands on Yerba Buena Island. All but two of the approximately 150 acres on Yerba Buena Island would continue to remain free from the Tidelands Trust and the land use restrictions placed on Trust lands.

²⁴ The Tidelands Trust limits the types of uses that can be developed on those properties. Under the 1997 Treasure Island Conversion Act (Cal. Health & Safety Code §33492.5), existing uses on Treasure Island that are inconsistent with the Tidelands Trust, such as the existing residential buildings, are permitted to continue for their remaining useful life, defined as no less than 25 years or no more than 40 years from the date of the Act.

²⁵ The approximately 37 acres occupied by the Job Corps campus would remain in Federal ownership and would not be subject to the Trust.

Public comment during public scoping for this EIR questioned the usefulness of a No Public Trust Exchange Agreement alternative. TIDA rejected this alternative because it would not achieve many of the basic project objectives. It would not allow for development of new housing units on Treasure Island, including both market-rate and affordable rental and for-sale units, and would require that use of all existing residential units be phased out over the next 25-40 years. This alternative was also rejected because the types of non-residential uses permitted under the Tidelands Trust would not achieve the project sponsors' objectives to create a new, unique mixed-use San Francisco neighborhood, implement a land use program with high-density residential areas located within walking distance of transit. Additionally, without the proposed residential development, the Proposed Project would not be able to finance and support proposed infrastructure and transportation improvements, a new regional waterfront system of parks and public open space, or implement sustainable design and development practices. Although Yerba Buena Island is not subject to the Tidelands Trust, and could be developed without the Public Trust Exchange Agreement, the project sponsors would not likely pursue development of residential units on Yerba Buena Island alone, as the island is topographically constrained and could not accommodate large amounts of residential development and neighborhood-serving retail or community service uses. Biological and cultural impacts associated with this alternative could also potentially be greater than those identified for the Proposed Project due to the presence of sensitive resources on Yerba Buena Island. This alternative was also rejected because of public comments that suggested that this alternative not be studied in the EIR.

● E.2 2800 HOUSING UNIT ALTERNATIVE WITH AN AMUSEMENT PARK

This alternative was analyzed as the Maximum Development Alternative in the *2005 Transfer and Reuse of Naval Station Island Final EIR* ("2005 Final EIR"). Under this alternative, residential land use would occupy about 30 percent of the Project Area, publicly oriented uses 35 percent, open space/recreation 26 percent, and community services 9 percent.

Under the 2005 Maximum Development Alternative analyzed in the 2005 Final EIR, the major publicly oriented development on Treasure Island would be a themed attraction with the potential to attract an average of 13,700 daily visitors and to employ up to approximately 3,500 seasonal and permanent workers. The plan would include 3 hotels, totaling 1,450 rooms. Existing film production facilities would be expanded by 100,000 square feet.

This alternative would include 2,500 housing units on Treasure Island and 300 units on Yerba Buena Island. This plan would reuse 200 of the existing 905 housing units on Treasure Island and 90 of the existing units on Yerba Buena Island. Land for housing for formerly homeless individuals and families would be available for the Treasure Island Homeless Development Initiative when new housing is constructed.

The alternative would provide seismic upgrades to the perimeter of Treasure Island only. A new utility corridor would run under the perimeter of Treasure Island, carrying both wet utilities (storm and sanitary sewer mains, water mains, and recycled water mains), and dry utilities (electricity, gas, and telecommunications lines). The utility corridor would also cross Treasure Island. As with the Proposed Project, a new combined police and fire station, and new or upgraded wastewater treatment plant would be provided. The existing Treasure Island shoreline band open space would be widened to approximately 100 feet and would include a bikeway and pedestrian path. The perimeter open space would be linked to parks, greens, and overlooks. Ferry terminals would be constructed on both the east and west sides of Treasure Island, providing service to the East Bay and to San Francisco.

This alternative was rejected because TIDA and the City and County of San Francisco decided that an amusement theme park would not be a desirable use for the long-term development of Treasure Island and Yerba Buena Island. As reflected in the Term Sheet endorsed by the Board of Supervisors, in the course of multiple meetings with stakeholders and decision-makers since completion of the *2005 EIR/EIS*, the land use plan underwent substantial revision and refinement designed to meet a variety of objectives. The prior land use plan, which relied heavily on visitor-serving commercial uses, was replaced with the Proposed Project. The alternative with 2800 residential units and an amusement park would not meet the project sponsors' objectives of providing a high-density, compact residential development located within walking distance of transit and providing high-density, mixed income housing with both ownership and rental opportunities. In addition, this alternative would not provide sufficient revenue to support construction of the infrastructure improvements necessary for development and the transit facilities proposed.



- THIS PAGE INTENTIONALLY LEFT BLANK



- **E.3 OFF-SITE LOCATION**

This alternative would involve development of the Proposed Project land uses at a site other than Treasure Island and Yerba Buena Island. An alternative location is required to be considered if feasible alternative locations exist that would avoid or substantially reduce any of the significant effects of the Proposed Project.²⁶ This alternative was not considered for further study in the EIR because there are no vacant or substantially underused parcels or designated redevelopment areas that could be available to TIDA that are large enough to accommodate the Proposed Project. In addition, developing the Proposed Project at another location would relocate many of the significant impacts identified for the Proposed Project, including transportation, noise, air quality, and visual impacts. Development of the Proposed Project at another location would not meet a fundamental purpose of TIDA, which is to redevelop the former Naval Station Treasure Island military base into a high-density urban neighborhood in San Francisco.

- **E.4 MEASURES TO REDUCE AUTOMOBILE OWNERSHIP**

A number of comments received during the public scoping process for EIR preparation suggested that the EIR should analyze alternatives with features designed to reduce reliance on private automobiles. Measures proposed included reduced parking, off-peak access fees, and additional incentives and services that could reduce automobile ownership. A reduced parking alternative is

- discussed above in Section VII.D. An alternative that would impose access fees, such as the proposed congestion pricing fee, during off-peak hours was not considered for further review in the EIR, as it would not reduce the significant transportation impacts associated with peak hour travel identified in Section IV.E, Transportation, to less-than-significant levels. Mitigation Measure M-TR-2, Expanded Transit Service, would be necessary to reduce impacts on Muni service capacity and traffic impacts on approaches to the Bay Bridge on-ramps. Many of the other measures suggested, such as an on-island shuttle, time limits for on-street parking, and car-share membership are already included in the Proposed Project. Other fine-grained measures
- such as grocery delivery services could be implemented as appropriate by the Treasure Island

²⁶ CEQA Guidelines Section 15126.6(f)(2).

Transportation Management Agency (“TITMA”). As such, the menu of modified transportation measures would not be an alternative to the Proposed Project. Based on the analysis in Section IV.E, Transportation, and in the *Transportation Impact Study* in Appendix C to this EIR, these measures would not be expected to reduce significant transportation, air quality, or noise impacts of the Proposed Project to less-than-significant levels.

● **F. ENVIRONMENTALLY SUPERIOR ALTERNATIVE**

An EIR is required to identify the environmentally superior alternative that has the fewest significant environmental impacts from among the alternatives evaluated. Besides the No Project Alternative, Alternative C, the No Ferry Service Alternative would be the environmentally superior alternative. The No Ferry Service Alternative would retain the *U.S.S. Buttercup*, and thereby avoid the significant adverse impact on that historical resource which would result from its demolition under the Proposed Project.

The elimination of ferry service under the No Ferry Service Alternative would also avoid some significant adverse noise, air quality and biological resource impacts related to ferry operations. The No Ferry Service Alternative would eliminate the significant impact on rafting waterfowl that would result from ferry operations under the Proposed Project. Mitigation Measure M-BI-4b to reduce impacts on rafting waterfowl, which would be implemented by the Water Emergency Transit Authority (“WETA”) and is therefore outside the jurisdiction of the City, would not be necessary. The health risks from diesel particulate matter would be reduced to less-than-significant levels with no ferry service. Mitigation Measure M-AQ-5 to reduce these emissions from ferry vessels, which would be implemented by WETA and is therefore outside the jurisdiction of the City, would not be necessary. The significant noise impacts that would result from the Proposed Project’s ferry service would be eliminated, and the operational mitigation measure identified for the Proposed Project, Measure M-NO-4, to be implemented by WETA and therefore outside the jurisdiction of the City, would not be necessary.

Due to the substantially smaller number of residential units that would be constructed, the No Ferry Service Alternative also would lessen (but not avoid) other significant adverse impact(s) identified for the Proposed Project related to the topics of Aesthetics, Transportation, Noise, Air Quality, and Biological Resources. The No Ferry Service Alternative could also lessen impacts of the Proposed Project that were found to be less than significant, or less than significant with mitigation, related to the topics of land use, archaeological and paleontological resources, greenhouse gas emissions, shadow, recreation, utilities and service systems, public services, Geology and Soils, Hazards and Hazardous Materials, Mineral and Energy Resources, and agricultural resources due to the reduced number of residential units, the reduced development footprint and the reduced number of tower structures.

VIII. AUTHORS AND PERSONS CONSULTED

EIR AUTHORS

Planning Department, City and County of San Francisco
1650 Mission Street, Suite 400
San Francisco, CA 94103

Environmental Review Officer:	Bill Wycko
Environmental Review Coordinator:	Rick Cooper
Environmental Planner:	Andrea Contreras, LEED AP
Preservation Technical Specialist:	Sophie Middlebrook Hayward
Senior Transportation Planner:	Viktoriya Wise, AICP, LEED AP
Archeologist:	Randall Dean

San Francisco City Attorney's Office
City Hall, Room 234
San Francisco, CA 94102

Deputy City Attorney:	John D. Malamut
Deputy City Attorney:	Andrea Ruiz-Esquide

EIR CONSULTANTS

Turnstone Consulting
330 Townsend Street, Suite 216
San Francisco, CA 94107

Project Director:	Nancy Cunningham Clark
Project Manager:	Barbara W. Sahn
Deputy Project Manager:	Donna R. Pittman
Senior Planner:	Michael Kometani
Senior Planner:	Michael Li
Senior Planner:	Julie Tilley Barlow, AICP
Senior Transportation Planner:	Luba C. Wyznyckyj, AICP
Senior Scientist:	William F. Dietrich
Staff Planner:	Eric Dupré
Staff Planner:	Peter Mye
Staff Scientist:	Barbara Westree
Research Editor:	Elizabeth Haines
Project Coordinator:	Juliana Clark

Environmental Science Associates
225 Bush Street, Suite 1700
San Francisco, CA 94104

Deborah Kirtman, AICP
Charles B. Bennett
Reema Y. Mahamood
Chris Sanchez
Eric Schniewind

Tom Roberts
Robert Eckard

Applied Marine Sciences (Marine Biology)
4749 Bennett Drive, Suite L
Livermore, CA 94551
Jay Johnson, Principal

Archeo-Tec (Archaeology)
5283 Broadway
Oakland, CA 96418
Allen Pastron, President

Fehr & Peers (Transportation)
332 Pine Street, 4th Floor
San Francisco, CA 94104
Chris Mitchell, PE
Todd Henry

Knapp and Associates (Historic Resources)
724 Pine Street
San Francisco, CA 94108
Frederic Knapp

Square One Productions (Visual Simulations)
1736 Stockton Street
San Francisco, CA 94133
Angela Lin

PROJECT SPONSORS

Treasure Island Development Authority (TIDA)

City of San Francisco
Office of Economic and Workforce Development
City Hall, Room 448
1 Dr. Carlton B. Goodlett Place
San Francisco, CA 94102

Jack Sylvan, Director
Michael Tymoff, Project Manager

Treasure Island Community Development (TICD)

Wilson Meany Sullivan
Four Embarcadero Center, Suite 3300
San Francisco, CA 94111

Kheay Loke
Alexandra Galovich

VIII. Authors and Persons Consulted

Lennar Corporation
1 California, Suite 2700
San Francisco, CA 94111

Stephen Proud
Kim Diamond

Kenwood Investments
100 Spear Street, Suite 1600
San Francisco, CA 94105

PROJECT ATTORNEYS

Gibson, Dunn & Crutcher
555 Mission Street, Suite 3000
San Francisco, CA 94105

Mary G. Murphy
Neil H. Sekhri

PROJECT ARCHITECTS

Perkins + Will
185 Berry St., Lobby One, Suite 5100
San Francisco, California 94107

Karen Alschuler, Principal

Paul, Hastings, Janofsky & Walker LLP
55 Second Street, Twenty-Fourth Floor
San Francisco, CA 94105

Deborah Schmall

Skidmore Owings & Merrill
One Front Street, Suite 2400
San Francisco, CA 94111

Craig Hartman, Principal

OTHER PROJECT SPONSOR CONSULTANTS

Page & Turnbull (Historic Resources)
724 Pine Street
San Francisco, CA 94108

Jay Turnbull
Carolyn Kiernat
Gretchen Hilyard

BKF Engineers Surveyor Planners
255 Shoreline Drive, Suite 200
Redwood City, CA 94065

Todd Adair, P.E.
Tom Morse
Suzanne King

Moffatt and Nichol (Coastal Flooding, Ferry Harbor Design)
2001 North Main Street, Suite 360
Walnut Creek, CA 94596

Christopher Devick
Dilip Trivedi
Ted Bell

VIII. Authors and Persons Consulted

Arup (Energy)
901 Market Street, Suite 260
San Francisco, CA 94103

Jean Rogers
Martin Howell
Chris Brosz
Orion Fulton

CMG Landscape Architecture
500 Third Street, Suite 215
San Francisco, CA 94107

Willet Moss
Kevin Conger
Brennan Cox
Jamie Philips

ENGEO Incorporated (Geotechnical)
332 Pine Street, Suite 300
San Francisco, CA 94104

Stefanos Papdopoulos, PE
Uri Eliahu, GE

Donald J. Ballanti (Wind)
Certified Consulting Meteorologist
1424 Scott Street
El Cerrito, CA 94530

Donald Ballanti

AECOM
155 Grand Avenue, Suite 700
Oakland, CA 94612

Bill Burton

Brown and Caldwell
201 North Civic Drive, Suite 115
Walnut Creek, CA 94596

Tracy Stigers
Ron Crites

Arcadis (formerly LFR)
1900 Powell Street, 12th Floor
Emeryville, CA 94608-1827

Bill Carson

URS Corporation (TIDA Peer Review: Infrastructure and Sea Level Rise)
221 Main Street, Suite 600
San Francisco, CA 94105

Tom Sweet

SERA Architects (TIDA Peer Review: Design for Development)
338 NW 5th Avenue
Portland, OR 97209

Tim Smith

Nelson Nygaard (TIDA Peer Review: Transportation)
785 Market Street, Suite 13000
San Francisco, CA 94103

Bonnie Nelson

VIII. Authors and Persons Consulted

AMEC Geomatrix (TIDA: Environmental)
2101 Webster Street, 12th Floor
Oakland, CA 94612

Gary Foote

Economic Planning Systems (TIDA: Employment Projections)
2501 Ninth Street, Suite 200
Berkeley, CA 94710

Richard Berkson

Seifel Consulting (TIDA: Housing and Redevelopment Plan)
221 Main Street, Suite 420
San Francisco, CA 94105

Libby Seifel

AGENCIES AND PERSONS CONSULTED

San Francisco Public Utilities Commission
1145 Market Street, Suite 400
San Francisco, CA 94103

John Loiacono

San Francisco Municipal Transportation Agency
1 South Van Ness Avenue
San Francisco, CA 94103

Peter Albert
Peter Straus
Julie Kirschbaum

San Francisco Bay Area Water Emergency Transportation Authority
Pier 9, Suite 111, The Embarcadero
San Francisco, CA 94111

John Sindzinski

California Department of Transportation (Caltran)
Local Development-Intergovernmental Review
111 Grand Avenue
PO Box 23660
Oakland, CA 94623-0660

Lisa Carboni
Yatman Kwan
Rodney Oto

PBS&J (Water Supply Assessment)
1410 Rocky Ridge Drive
Roseville, CA 95661