

24 3D - UPPER STAIRS

19 3D OVERLOOK

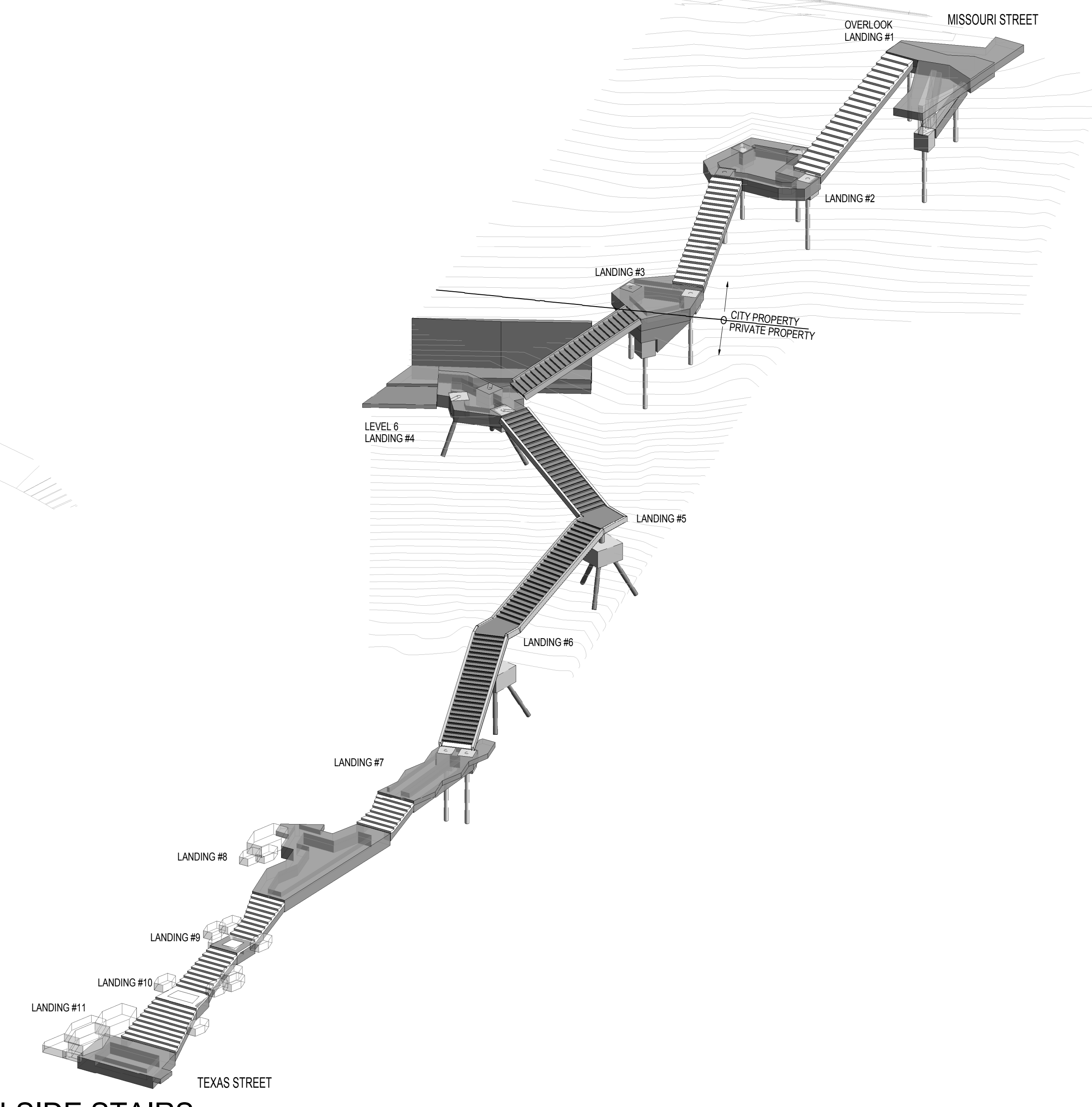

9 3D - HILLSIDE STAIRS

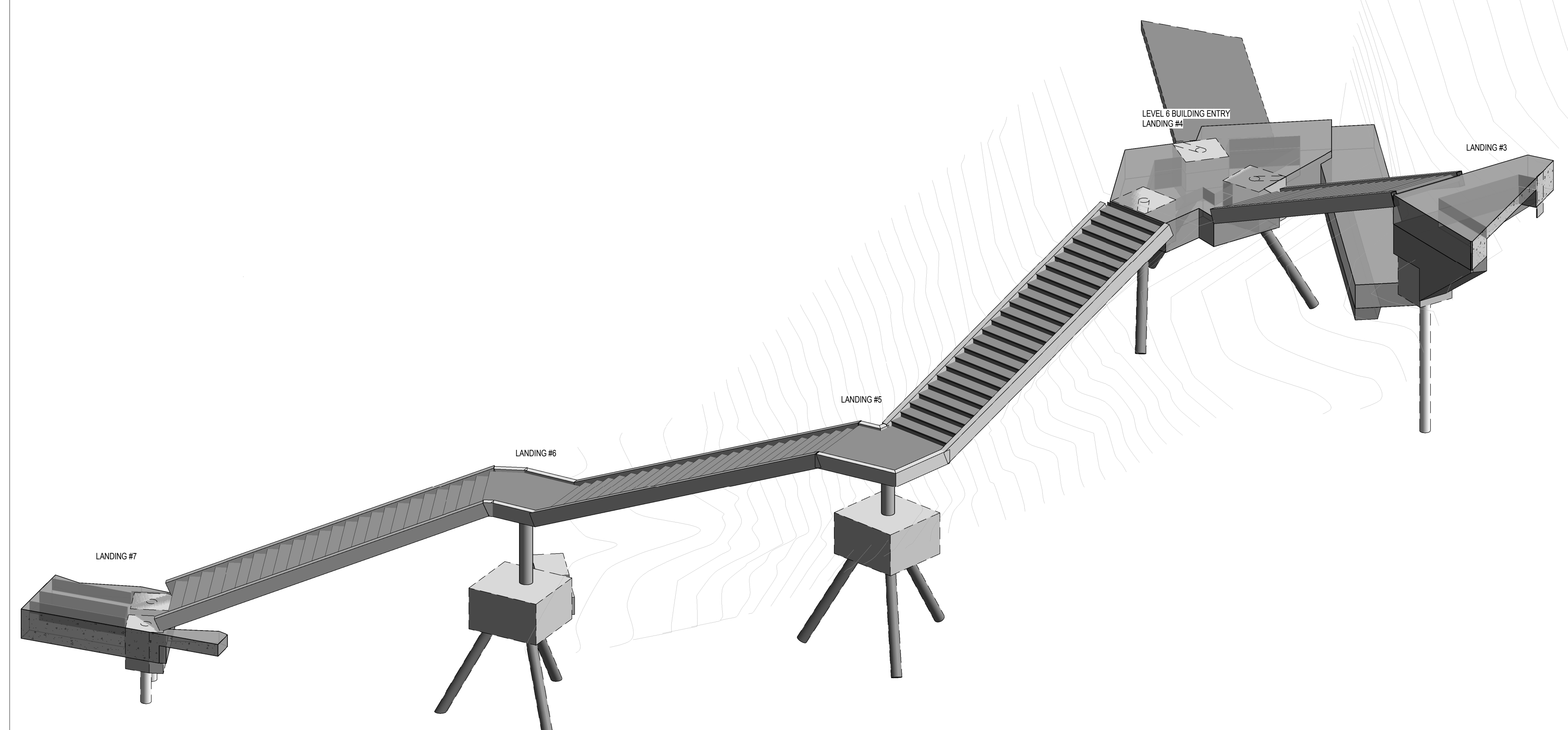

22 3D - HILLSIDE ELEVATED STEEL STAIRS

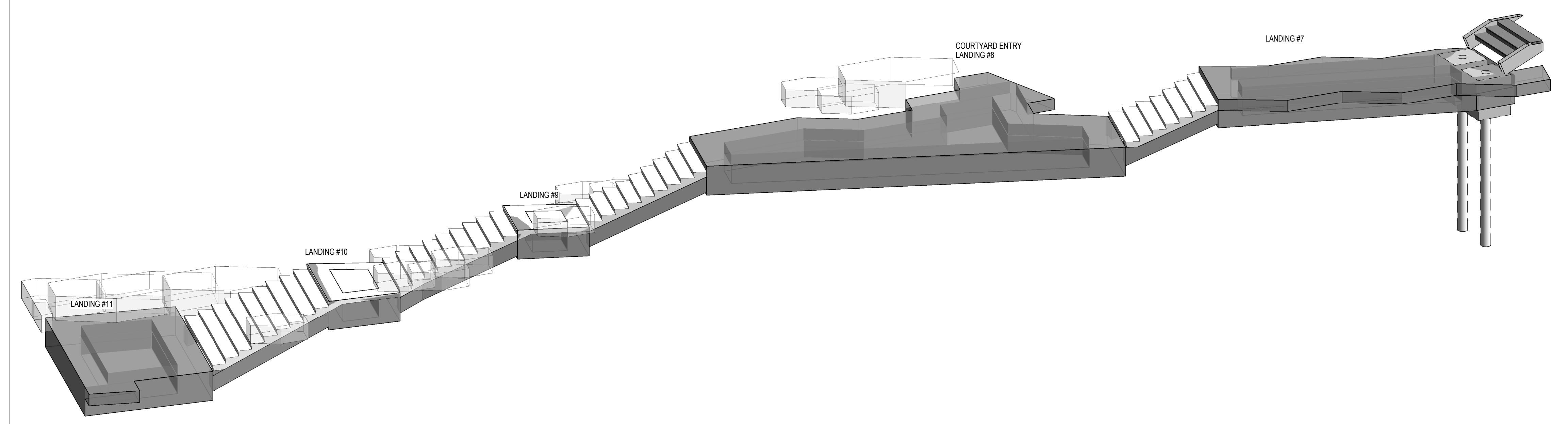

21 3D - LOWER STAIRS

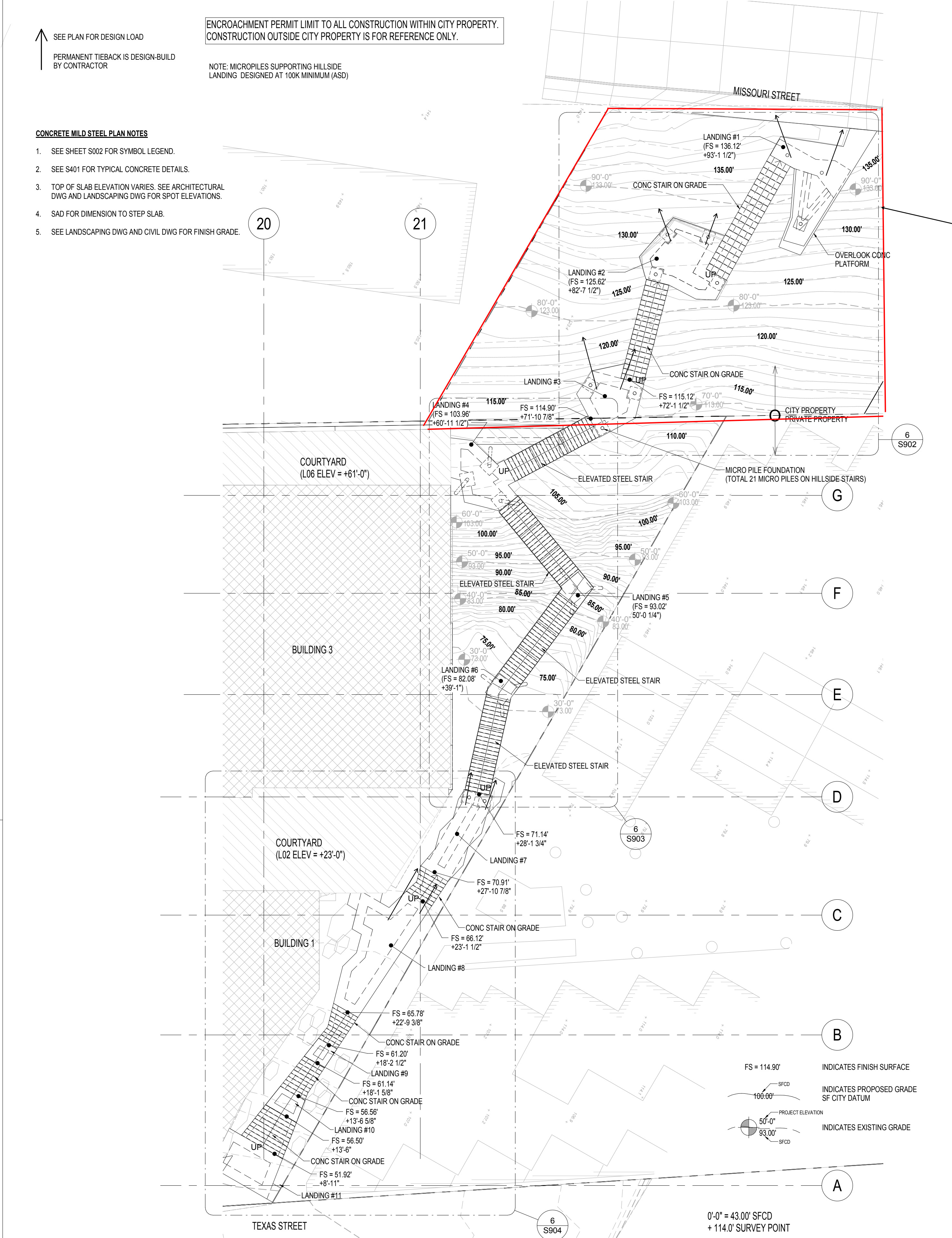

6 HILLSIDE STAIRS OVERALL PLAN

Structure within the ROW

PROJECT KEY PLAN

1395 22ND STREET
 SAN FRANCISCO, CALIFORNIA
ALIGN
 REAL ESTATE

ISSUE HISTORY	
75% SCHEMATIC DESIGN	10/23/15
100% SCHEMATIC DESIGN	12/16/15
100% SCHEMATIC DESIGN	02/18/16
100% DESIGN DEVELOPMENT	08/19/16
50% CONSTRUCTION DRAWINGS	11/18/16
75% CONSTRUCTION DRAWINGS	01/06/17
MAJOR ENCROACHMENT PERMIT	03/15/17
ADDENDUM #1 - FOUNDATION	05/24/17

PROJECT NUMBER 7502
 SCALE As indicated
 SHEET TITLE **HILLSIDE STAIRS OVERALL PLAN**
 SHEET NUMBER **S901**
 PROFESSIONAL SEAL

