



SFMTA
Municipal
Transportation
Agency

Edwin M. Lee, *Mayor*

Tom Nolan, *Chairman*

Malcolm Heinicke, *Director*

Joél Ramos, *Director*

Edward D. Reiskin, *Director of Transportation*

Cheryl Brinkman, *Vice-Chairman*

Jerry Lee, *Director*

Cristina Rubke, *Director*

MEMORANDUM

Date: May 24, 2016

To: Christopher Espiritu, San Francisco Planning Department

From: Casey Hildreth, San Francisco Municipal Transportation Agency

Through: Erik Jaszewski, San Francisco Municipal Transportation Agency

Subject: Turk and Leavenworth Bulb-Outs

The San Francisco Municipal Transportation Agency (SFMTA) proposes to construct three (3) concrete sidewalk bulb-outs at the intersections of Eddy and Leavenworth Street, Turk and Leavenworth Street, and Turk and Jones Street. These bulb-outs would replace three existing painted safety zones¹ (PSZs) and would occupy approximately the same area; more detail can be found in **Appendix A**. The three bulb-outs would be installed at the following locations:

- Eddy Street/Leavenworth Street – pedestrian bulb on southeast corner
- Turk Street/Leavenworth Street – pedestrian bulb on southwest corner
- Turk Street/Jones Street – pedestrian bulb on southeast corner

No more than three parking spaces would foreseeably be removed as part of the project, though likely no parking loss would result. The proposed bulb-outs would require excavation to a depth of approximately three feet in the public right-of-way.

Categorically Exempt pursuant to CEQA as defined in CEQA Guidelines Section 15301 Class 1(c):
Operation, repair, maintenance, or minor alteration of existing public facilities including existing highways and streets, sidewalks, gutters, bicycle and pedestrian trails, and similar facilities

5/24/2016

Erik Jaszewski
San Francisco Municipal Transportation Agency

Date

5/25/2016

Christopher Espiritu
San Francisco Planning Department

Date

¹ Painted Safety Zone refers to an area of the roadway surface delineated with khaki-colored paint and usually soft-hit posts in the appearance of a sidewalk bulb-out. This treatment is intended to improve safety for pedestrians crossing an intersection.



SAN FRANCISCO PLANNING DEPARTMENT

ENVIRONMENTAL EVALUATION APPLICATION COVER MEMO - PUBLIC PROJECTS ONLY

In accordance with Chapter 31 of the San Francisco Administrative Code, an appeal of an exemption determination can only be filed within 30 days of the project receiving the first approval action.

Please attach this memo along with all necessary materials to the Environmental Evaluation Application.

Project Address and/or Title:	Turk and Leavenworth Bulb-Outs
Project Approval Action:	SF Board of Supervisors - Authorization to Execute Grant
Will the approval action be taken at a noticed public hearing? <input checked="" type="checkbox"/> YES* <input type="checkbox"/> NO	
* If YES is checked, please see below.	

IF APPROVAL ACTION IS TAKEN AT A NOTICED PUBLIC HEARING, INCLUDE THE FOLLOWING CALENDAR LANGUAGE:

End of Calendar: CEQA Appeal Rights under Chapter 31 of the San Francisco Administrative Code If the Commission approves an action identified by an exemption or negative declaration as the Approval Action (as defined in S.F. Administrative Code Chapter 31, as amended, Board of Supervisors Ordinance Number 161-13), then the CEQA decision prepared in support of that Approval Action is thereafter subject to appeal within the time frame specified in S.F. Administrative Code Section 31.16. Typically, an appeal must be filed within 30 calendar days of the Approval Action. For information on filing an appeal under Chapter 31, contact the Clerk of the Board of Supervisors at City Hall, 1 Dr. Carlton B. Goodlett Place, Room 244, San Francisco, CA 94102, or call (415) 554-5184. If the Department’s Environmental Review Officer has deemed a project to be exempt from further environmental review, an exemption determination has been prepared and can be obtained on-line at <http://sf-planning.org/index.aspx?page=3447>. Under CEQA, in a later court challenge, a litigant may be limited to raising only those issues previously raised at a hearing on the project or in written correspondence delivered to the Board of Supervisors, Planning Commission, Planning Department or other City board, commission or department at, or prior to, such hearing, or as part of the appeal hearing process on the CEQA decision.

Individual calendar items: This proposed action is the Approval Action as defined by S.F. Administrative Code Chapter 31.

THE FOLLOWING MATERIALS ARE INCLUDED:

- 2 sets of plans (11x17)
- Project description
- Photos of proposed work areas/project site
- Necessary background reports (specified in EEA)
-

APPENDIX A
Plan Drawings



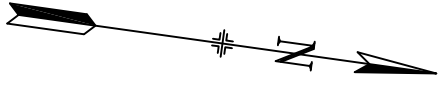

LEAVENWORTH ST

PAINTED SAFETY ZONE

EDDY ST.

STAMPED CROSSWALKS

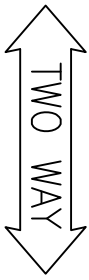

SAFE HIT POSTS
4 @ 7 FT

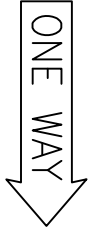

150' 4" - BW

12" SW TYP

12" SOLID WHITE

DETAIL
40

12'

44' 9"

12'

24'

6'

17' 10' 17'

STOP

STOP

4" BW

22' 4 1/2"

22' 4 1/2"

12'

44' 9"

12'



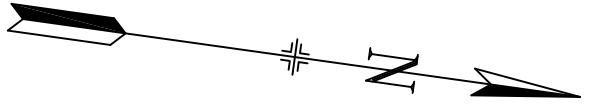

LEAVENWORTH ST

PAINTED SAFETY ZONE DETAIL A

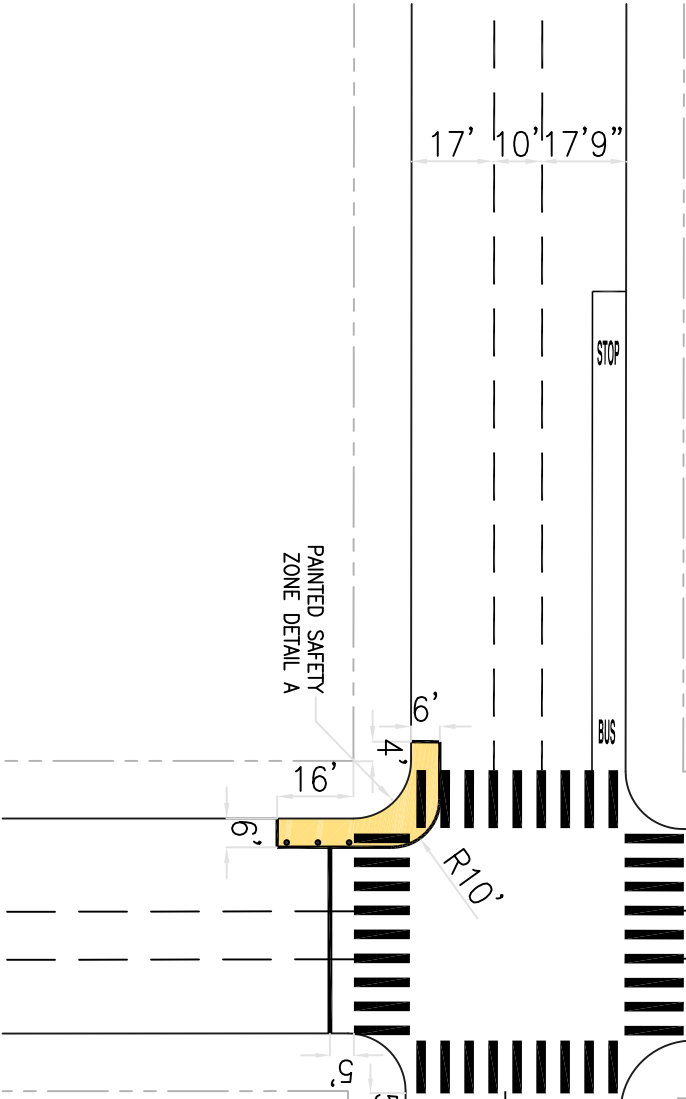

ONE WAY

PAINTED SAFETY ZONE

DETAIL A

TURK ST

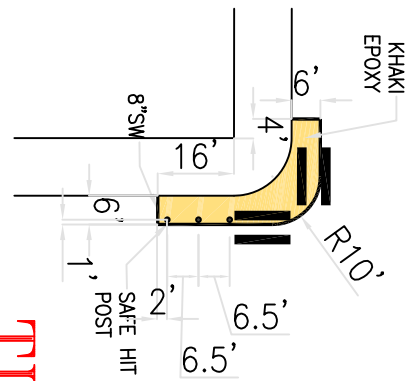

ONE WAY

4" BW

12' 44' 9" 12'

412'±

TURK ST

YELLOW
LADDER
X-WALK

17' 10' 18'

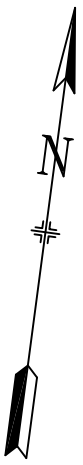

17' 10' 18'

R15'

20'



PAINTED SAFETY
ZONE
DETAIL A

PAINTED SAFETY ZONE

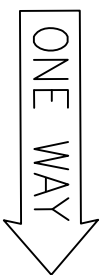

JONES ST

8" BW
4" BW

12' 44' 9" 12'

17' 6" 10' 17' 3"

14'

5'-6" 5'-6" 5'-6" 5'-6"

SAFE HIT
POST

DETAIL A

