

File No. 210159

Committee Item No. 2

Board Item No. 2

COMMITTEE/BOARD OF SUPERVISORS

AGENDA PACKET CONTENTS LIST

Committee: Budget & Finance Committee

Date April 7, 2021

Board of Supervisors Meeting

Date April 20, 2021

Cmte Board

- | | | |
|-------------------------------------|-------------------------------------|--|
| <input type="checkbox"/> | <input type="checkbox"/> | Motion |
| <input type="checkbox"/> | <input type="checkbox"/> | Resolution |
| <input checked="" type="checkbox"/> | <input checked="" type="checkbox"/> | Ordinance |
| <input checked="" type="checkbox"/> | <input checked="" type="checkbox"/> | Legislative Digest |
| <input checked="" type="checkbox"/> | <input checked="" type="checkbox"/> | Budget and Legislative Analyst Report |
| <input type="checkbox"/> | <input type="checkbox"/> | Youth Commission Report |
| <input type="checkbox"/> | <input type="checkbox"/> | Introduction Form |
| <input checked="" type="checkbox"/> | <input checked="" type="checkbox"/> | Department/Agency Cover Letter and/or Report |
| <input type="checkbox"/> | <input type="checkbox"/> | MOU |
| <input type="checkbox"/> | <input type="checkbox"/> | Grant Information Form |
| <input type="checkbox"/> | <input type="checkbox"/> | Grant Budget |
| <input type="checkbox"/> | <input type="checkbox"/> | Subcontract Budget |
| <input checked="" type="checkbox"/> | <input checked="" type="checkbox"/> | Contract/Agreement |
| <input checked="" type="checkbox"/> | <input checked="" type="checkbox"/> | Form 126 – Ethics Commission |
| <input type="checkbox"/> | <input type="checkbox"/> | Award Letter |
| <input type="checkbox"/> | <input type="checkbox"/> | Application |
| <input type="checkbox"/> | <input type="checkbox"/> | Public Correspondence |

OTHER (Use back side if additional space is needed)

- | | | |
|-------------------------------------|-------------------------------------|--|
| <input checked="" type="checkbox"/> | <input checked="" type="checkbox"/> | <u>SFPUC Resolution No. 21-0010</u> |
| <input checked="" type="checkbox"/> | <input checked="" type="checkbox"/> | <u>Planning Department's CEQA Determination - October 24, 2019</u> |
| <input type="checkbox"/> | <input checked="" type="checkbox"/> | <u>SFPUC Presentation - April 7, 2021</u> |
| <input type="checkbox"/> | <input type="checkbox"/> | _____ |
| <input type="checkbox"/> | <input type="checkbox"/> | _____ |
| <input type="checkbox"/> | <input type="checkbox"/> | _____ |
| <input type="checkbox"/> | <input type="checkbox"/> | _____ |
| <input type="checkbox"/> | <input type="checkbox"/> | _____ |
| <input type="checkbox"/> | <input type="checkbox"/> | _____ |
| <input type="checkbox"/> | <input type="checkbox"/> | _____ |
| <input type="checkbox"/> | <input type="checkbox"/> | _____ |

Completed by: Linda Wong Date April 2, 2021

Completed by: Linda Wong Date April 9, 2021

1 [Transmission Facilities Agreement - Pacific Gas and Electric Company - Electric Grid
2 Interconnection - \$21,165,000]

3 **Ordinance approving a Transmission Facilities Agreement with Pacific Gas and Electric**
4 **Company to interconnect City-owned transmission facilities to the electric grid for a**
5 **total cost of \$21,165,000 and a term of four years and three months commencing in**
6 **April 2021 and ending in June 2025, and waiving certain provisions of the**
7 **Administrative and Environment Codes.**

8 NOTE: **Unchanged Code text and uncodified text** are in plain Arial font.
9 **Additions to Codes** are in *single-underline italics Times New Roman font*.
10 **Deletions to Codes** are in *strikethrough italics Times New Roman font*.
11 **Board amendment additions** are in double-underlined Arial font.
12 **Board amendment deletions** are in ~~strikethrough Arial font~~.
13 **Asterisks (* * * *)** indicate the omission of unchanged Code
14 subsections or parts of tables.

15 Be it ordained by the People of the City and County of San Francisco:

16 Section 1. Background and Findings.

17 (a) The Public Utilities Commission (PUC) is constructing the Bay Corridor
18 Transmission and Distribution project (BCTD) which consists of a high voltage electric
19 transmission line, transmission substation, and related electric facilities in the southeast area
20 of the City. The PUC will interconnect new customers in the southeast area directly to the
21 BCTD, thereby avoiding distribution level connections with Pacific Gas and Electric (PG&E)
22 for these customers and avoiding the significant disputes, delays, and high costs associated
23 with interconnecting and serving customers through PG&E's distribution system.

24 (b) The BCTD must be interconnected to PG&E's transmission system in order to
25 energize the BCTD and deliver Hetch Hetchy power to customers. The BCTD will be
connected at PG&E's Potrero Switchyard located at 1201 Illinois Street. In order to provide

1 service to BCTD, PG&E will design and construct upgrades to PG&E's switchgear at the
2 Potrero Switchyard and a line to the PUC's new substation located on Davidson Avenue
3 (Upgrades) and the PUC will pay PG&E \$18,600,000 for the cost of the Upgrades. In
4 addition, after construction and energization of the Upgrades, the PUC will pay PG&E a
5 monthly cost of ownership charge of \$57,000 for the 45 month term of the TFA to own,
6 operate, maintain, and repair the Upgrades for a total of \$2,565,000 in monthly charges for
7 the term of the TFA.

8 (c) The PUC and PG&E must execute a Transmission Facilities Agreement (TFA)
9 providing for the construction of the Upgrades. The draft TFA is on file with the Clerk of the
10 Board of Supervisors in File No. 210159 and is incorporated by reference as if fully set forth
11 herein. The Public Utilities Commission approved the TFA at its meeting on January 26,
12 2021 in Resolution No. 21-0010.

13 (d) The TFA is a form agreement that is part of PG&E's Transmission Owner Tariff
14 and is approved by the Federal Energy Regulatory Commission (FERC). Because the TFA is
15 a tariffed form agreement that must comply with FERC requirements, it is not possible to
16 include the City's standard contract terms and conditions in the TFA.

17 (e) The TFA will take effect upon approval by FERC and expire on June 30, 2025.
18 Upon expiration of the TFA, the PUC anticipates that it will enter into a second TFA with
19 PG&E for the continued operation, maintenance, and repair of the Upgrades.

20 (f) The City Attorney has approved the liability and idemnification language set forth in
21 sections 19 and 20 of the TFA.

22 (g) The PUC's Risk Manager has approved the insurance language set forth in the
23 TFA.

24 (h) The PUC's Bureau of Environmental Management determined that the construction
25 of the new Davidson Substation and connection to the PG&E Potrero Switchyard is

1 categorically exempt under CEQA Guidelines Section 15303 and on October 24, 2019 the
2 Planning Department concurred with this determination under case number 2019-
3 013330ENV.

4
5 Section 2. Authorization of the TFA. Pursuant to Charter Section 9.118, the Board of
6 Supervisors hereby authorizes the General Manager of the PUC to execute the TFA with
7 PG&E in an amount not to exceed \$21,165,000 for construction of the Upgrades and the
8 \$57,000 monthly charges, and to make modifications to the agreement so long as the General
9 Manager and City Attorney determine that the modifications do not materially decrease the
10 City's rights or increase its liabilities.

11
12 Section 3. Waivers of the Administrative Code and the Environment Code.

13 (a) The Board of Supervisors hereby waives the following Administrative and
14 Environment Code sections for the TFA and finds such waivers to be necessary and in the
15 public interest:

- 16 (1) Non-discrimination in contracts (Admin. Code Chapter 12B);
17 (2) Minimum compensation (Admin. Code Chapter 12P);
18 (3) Health care accountability (Admin. Code Chapter 12Q);
19 (4) Consideration of criminal history in hiring (Admin. Code Chapter 12T);
20 (5) Increased participation by small and micro local businesses in City
21 contracts (Admin. Code Chapter 14B);
22 (6) The competitive bidding requirement (Admin. Code Section 21.1);
23 (7) First source hiring requirements (Admin. Code Chapter 83);
24 (8) The tropical hardwood and virgin redwood ban (Environ. Code
25 Chapter 8); and

1 (9) Preservative treated wood products (Environ. Code Chapter 13).

2 (b) The Board of Supervisors waives the requirement to include in the TFA
3 references to the following City Code provisions and finds such waivers to be reasonable and
4 in the public interest:

5 (1) Use of City funds for political activities (Admin. Code Chapter 12G); and

6 (2) Guaranteed maximum costs (Admin. Code Section 21.19).

7
8 Section 4. Effective Date. This ordinance shall become effective 30 days after
9 enactment. Enactment occurs when the Mayor signs the ordinance, the Mayor returns the
10 ordinance unsigned or does not sign the ordinance within ten days of receiving it, or the Board
11 of Supervisors overrides the Mayor's veto of the ordinance.

12
13 APPROVED AS TO FORM:
14 DENNIS J. HERRERA, City Attorney

15 By: /s/
16 THERESA CHO
17 Deputy City Attorney

18
19
20
21
22
23
24
25
n:\legana\as2021\2100263\01509648.docx

LEGISLATIVE DIGEST

[Approving Transmission Facilities Agreement - Pacific Gas and Electric Company - Electric Grid Interconnection - \$21,165,000]

Ordinance approving a Transmission Facilities Agreement with Pacific Gas and Electric Company to interconnect City-owned transmission facilities to the electric grid for a total cost of \$21,165,000 and a term of four years and three months commencing in April 2021 and ending in June 2025, and waiving certain provisions of the Administrative and Environment Codes.

Existing Law

The San Francisco Municipal Code contains many contracting requirements for the procurement of goods and services. The Board of Supervisors may exempt contracts from these requirements via ordinance.

Amendments to Current Law

The ordinance does not amend current law.

Background Information

The Public Utilities Commission (PUC) is nearing completion of the construction of the Bay Corridor Transmission and Distribution project (BCTD), a \$166.6 million project which consists of a high voltage electric transmission line, transmission substation (Davidson Substation), distribution lines, and related electric facilities in the southeast area of the City. When completed, the PUC will deliver 100% greenhouse gas free Hetch Hetchy power to PUC customers along Pier 50 to South of Islais Creek through BCTD. The BCTD will allow the PUC to bypass PG&E distribution services, thereby avoiding the excessive delays and costs associated with PG&E distribution service.

The Davidson Substation must be connected to PG&E's transmission system in order to energize the BCTD and deliver Hetch Hetchy power to PUC customers. The BCTD will interconnect to PG&E's Potrero Switchyard and PG&E must construct certain transmission facilities to accommodate the BCTD, including upgrades to PG&E's equipment at the Potrero Switchyard and a high voltage underground cable (Upgrades). The PUC must enter into a Transmission Facilities Agreement (TFA) with PG&E for the construction of the Upgrades, reimbursement to PG&E for the cost of the Upgrades, and monthly charges for PG&E's ownership, operation, maintenance, and repair of the Upgrades. If the PUC does not execute the TFA, the BCTD cannot go into operation.

The total cost of the TFA is estimated at \$21,165,000. The cost of the Upgrades is \$18,600,000 and includes engineering work, equipment and materials, construction, and testing and commissioning. To date, the PUC has made a \$1,750,000 payment for engineering work and a \$3,000,000 payment for equipment under two previous agreements with PG&E. These amounts will be credited to the PUC against the \$18,600,000 cost of the contract.

When the Upgrades are completed and the BCTD is energized, the PUC will pay PG&E \$57,000 per month for the remaining term of the TFA. The TFA will expire on June 30, 2025 and the PUC estimates that the BCTD will be energized in October 2021, resulting in 45 months of monthly charges for a total of \$2,565,000. When the TFA expires in 2025, the PUC anticipates that it will enter into a second TFA with PG&E for the continued operation and maintenance of the Upgrades. The PUC will obtain all required approvals for the second TFA at that time.

The TFA is a form agreement that was approved by the Federal Energy Regulatory Commission (FERC) as part of PG&E's Transmission Owner Tariff and the TFA must be approved by FERC. Because the TFA is a tariffed form agreement, PG&E will not agree to include the terms and conditions for City contracts in the Administrative and Environment Codes. Therefore, the ordinance seeks waivers of certain provisions of the Administrative and Environment Codes for the TFA.

n:\legana\as2021\2100263\01509650.docx

Item 2 File 21-0159	Department: Public Utilities Commission (PUC)
EXECUTIVE SUMMARY	
<p>Legislative Objectives</p> <ul style="list-style-type: none"> • The proposed ordinance would approve a Transmission Facilities Agreement (TFA) between San Francisco Public Utilities Commission (SFPUC) and Pacific Gas and Electric Company (PG&E) to interconnect City-owned transmission facilities to the electric grid for a term of four years and three months from April 2021 through June 2025, for an amount to be paid by SFPUC not to exceed \$21,165,000, and waive certain provisions of the Administrative and Environment Codes. <p>Key Points</p> <ul style="list-style-type: none"> • SFPUC’s Power Enterprise Bay Corridor Transmission and Distribution Project (BCTD) is a \$166.6 million project consisting of a high voltage transmission line, transmission substation (Davidson Substation), distribution lines, and related electric facilities in the southeast area of the City. The project will deliver Hetch Hetchy power to City facilities and other SFPUC customers between Pier 50 and south of Islais Creek, bypassing PG&E distribution services. The Davidson Substation would need to be connected to PG&E’s Potrero Switchyard to power the BCTD, which requires PG&E to upgrade the Potrero Switchyard to connect to the BCTD. <p>Fiscal Impact</p> <ul style="list-style-type: none"> • Under the proposed TFA, the not-to-exceed cost for SFPUC would be \$21,165,000. This amount is comprised of (i) \$15,000,000 for Substation work, (ii) \$3,600,000 to compensate PG&E for income taxes it must pay (Income Tax Component of Contribution, or ITCC), and (iii) \$2,565,000 for 45 months of Cost of Ownership Charges, at an amount of \$57,000 per month. • The \$18,600,000 amount for the Substation work and ITCC would be funded by the SFPUC Hetch Hetchy Power Enterprise capital budget, and the \$2,565,000 in Cost of Ownership Charges would be funded by the Hetch Hetchy Power Enterprise operating budget. • The SFPUC has already made related payments to PG&E of \$4,750,000 under a separate agreement. Costs included a feasibility study, engineering design work, and purchase the necessary equipment that has a long-lead time. These costs are also included in the proposed TFA. <p>Recommendation</p> <ul style="list-style-type: none"> • Approve the proposed ordinance. 	

MANDATE STATEMENT

City Charter Section 9.118(b) states that any contract entered into by a department, board or commission that (1) has a term of more than ten years, (2) requires expenditures of \$10 million or more, or (3) requires a modification of more than \$500,000 is subject to Board of Supervisors approval.

BACKGROUND

The San Francisco Public Utilities Commission (SFPUC) Power Enterprise Bay Corridor Transmission and Distribution Project (BCTD) is a \$166.6 million project consisting of a high voltage transmission line, transmission substation (Davidson Substation), distribution lines, and related electric facilities in the southeast area of the City. The project will deliver Hetch Hetchy power to City facilities and other SFPUC customers between Pier 50 and south of Islais Creek, bypassing Pacific Gas and Electric Company's (PG&E) distribution services.

The Davidson Substation, to be constructed at 1535 Davidson Avenue, would need to be connected to PG&E's Potrero Switchyard, located at 1201 Illinois Street, to power the BCTD. Connecting the Davidson Substation to the Potrero Switchyard requires PG&E to design, furnish equipment and materials, and expand its existing switchgear at the Potrero Switchyard to connect to the BCTD. In January 2021, the SFPUC Commission approved a Transmission Facilities Agreement (TFA) with PG&E to furnish and construct a new 230 kV interconnection from the Potrero Switchyard to the Davidson Substation.

DETAILS OF PROPOSED LEGISLATION

The proposed resolution would approve a TFA between SFPUC and PG&E to interconnect City-owned transmission facilities to the PG&E electric grid for a term of four years and three months from April 2021 through June 2025, for an amount not to exceed \$21,165,000, and waive certain provisions of the Administrative and Environment Codes.

According to Mr. Ramon Abueg, SFPUC Deputy Assistant General Manager, the BCTD system would allow SFPUC to serve customers directly. Otherwise, to provide Hetch Hetchy power to these customers, including City facilities, SFPUC would have to apply for a Wholesale Distribution Tariff (WDT) with PG&E.¹ According to Mr. Abueg, each service connection through the WDT requires costly upgrades to the PG&E system and installation of primary equipment; the cost invested in WDT services to upgrade the PG&E system benefits only PG&E. Additionally, according to Mr. Abueg, installation of primary equipment is duplicative in that PG&E installs the same equipment as installed by SFPUC to establish a utility to utility connection. This requires that the customers provide property that could otherwise be available for other uses to install

¹ According to the California Public Utilities Commission, the Wholesale Distribution Tariff is a tariff that describes the interconnection, operating and metering requirements for generation facilities to be connected to a utility's distribution system. The tariff provides customers wishing to install generating or storage facilities on their premises with access to the electric grid while protecting the safety and reliability of the distribution and transmission systems at the local and system levels.

the equipment. The BCTD project is intended to reduce costs to SFPUC and customers over the long-term, maintain control of the power distribution system, and eliminate the need for giving up space to accommodate the installation of duplicative equipment.

According to Mr. Abueg, the decision to supply Hetch Hetchy Power directly to the area between Pier 50 and south of Islais Creek is due to the number of City-owned facilities in the area, particularly the SFPUC's Southeast Treatment Plant, which is undergoing major upgrades through the Sewer System Improvement Project (SSIP). Other customers served by BCTD would include Seawall Lot 337, Pier 48, Pier 50, Mission Rock, Mission Bay Ferry Landing, Mariposa Pump Station, Pier 70, Booster Pump Station, Central Bayside Station, Bruce Flynn Station, Southeast Community Center, and University of California, San Francisco (UCSF).

The proposed TFA would expire June 30, 2025. According to Mr. Abueg, SFPUC would seek to renew the TFA once it expires. If renewed, SFPUC would continue paying PG&E the Cost of Ownership Charge of \$57,000 per month, an amount that would be fixed in perpetuity for the duration of the agreement.

The TFA is a form agreement that needs to be approved by the Federal Energy Regulatory Commission (FERC).² Because the TFA is a form agreement, it does not include the terms and conditions required for City contracts under the Administrative and Environment Codes.³ Therefore, the proposed ordinance would waive these provisions.

FISCAL IMPACT

Under the proposed TFA, the not-to-exceed cost for SFPUC would be \$21,165,000. This amount is comprised of (i) \$15,000,000 for Substation work, (ii) \$3,600,000 to compensate PG&E for income taxes it must pay (Income Tax Component of Contribution, or ITCC), and (iii) \$2,565,000 for 45 months of Cost of Ownership Charges, at an amount of \$57,000 per month. The cost breakdown for the TFA is shown in Table 1 below.

² A form agreement is a standard, or boilerplate, contract where the terms and conditions are set by one party and typically cannot be negotiated by the other party. Because the TFA must comply with FERC requirements, it is not possible to include the City's Administrative and Environment Code requirements.

³ Administrative and Environmental Code provisions waived by the proposed ordinance include non-discrimination in contracts (Admin Code Sec. 12B); minimum compensation (Admin Code Sec. 12P); health care accountability (Admin Code Sec. 12Q); consideration of criminal history in hiring (Admin Code Sec. 12T); small and micro local business participation (Admin Code Sec. 14B); competitive bidding (Admin Code Sec. 21.1); tropical hardwood and virgin redwood ban (Env. Code Chapter 8); preservative treated wood products (Env. Code Chapter 13); use of City funds for political activities (Admin Code Chapter 12B); and guaranteed maximum costs (Admin Code Sec. 21.19).

Table 1: TFA Cost Breakdown

Item	Amount
Substation Work	
Engineering	\$2,000,000
Project Management	1,500,000
Property Improvements	750,000
Station Equipment and Labor	3,500,000
Removal	50,000
Telecommunications	150,000
Testing	1,300,000
Maintenance & Operations	500,000
Land & Environmental	250,000
<i>Subtotal Project Costs</i>	<i>\$10,000,000</i>
Contract & Group Support	5,000,000
Substation Work Subtotal	\$15,000,000
Income Tax Component of Contribution	3,600,000
Cost of Ownership Charges	2,565,000
Total Not to Exceed Amount	\$21,165,000

Previously Paid Costs

Under a separate 2018 agreement with PG&E, the SFPUC made related payments of \$4,750,000 to perform a feasibility study for the interconnection, engineering design, and to purchase the necessary equipment that has a long-lead time. According to Mr. Abueg, FERC required that the costs also be included under the proposed TFA amount of \$21,165,000.

Contract and Group Support

The \$5,000,000 Contract & Group Support amount shown in Table 1 accounts for contingencies including environmental mitigation, coverage for loss of transmission clearance window due to system conditions, unforeseen or unknown items as a result of insufficient engineering, increase in overhead costs due to schedule delays, increase in labor due to level of effort being insufficient, and increased contract costs due to unexpected change orders. The Contract & Group Support amount of \$5,000,000 is one-third of total project costs estimated by PG&E to be \$15,000,000.

In accordance with the proposed TFA, SFPUC paid an initial charge of \$4,750,000 to PG&E for feasibility study, engineering work and purchase of the equipment. The TFA provides for PG&E to invoice SFPUC periodically for PG&E’s project costs, and to provide a final accounting of project costs at project completion. According to Mr. Abueg, the most recent scope and cost estimate provided by PG&E for the project is approximately \$11,000,000, or approximately \$1,000,000 more than the \$10,000,000 in direct project costs shown in Table 1 above, which would be paid from the \$5,000,000 Contract & Group Support contingency. The total Contract & Group Support contingency amount of \$5,000,000 is intended to provide sufficient spending authority to

prevent project delays that could disrupt the planned timing of connecting the new substation to the distribution system.⁴

Income Tax Component of Contribution

According to the proposed TFA, the Income Tax Component of Contribution is calculated based on PG&E's gross income realized for income tax purposes multiplied by the percentage set forth in PG&E's electric tariffs approved by the California Public Utilities Commission.

Cost of Ownership

The estimated Cost of Ownership is calculated based on PG&E's estimate of the cost of substation work of \$15,000,000 times the current FERC transmission customer-financed monthly Cost of Ownership rate, which is fixed at the time that the substation is placed into service. If the actual cost of substation work is less than \$15,000,000, the Cost of Ownership charge would be less.

The \$18,600,000 amount for the Substation work and ITCC would be funded by the SFPUC Hetch Hetchy Power Enterprise capital budget, and the \$2,565,000 in Cost of Ownership Charges would be funded by the Hetch Hetchy Power Enterprise operating budget.

RECOMMENDATION

Approve the proposed ordinance.

⁴ According to Mr. Abueg, the window for connecting the new substation to PG&E's electric grid is narrow because PG&E must shut down high voltage electricity for the interconnection work.

**TRANSMISSION FACILITIES AGREEMENT
BETWEEN
CITY AND COUNTY OF SAN FRANCISCO
AND
PACIFIC GAS AND ELECTRIC COMPANY**

Potrero Switchyard 230 kV Interconnection Project

At the request of City and County of San Francisco (“Customer” or “CCSF”), Pacific Gas and Electric Company (“PG&E”), a California corporation (collectively, “Parties”), agrees to furnish and construct, at the Customer’s expense, a new 230 kV interconnection from the PG&E Potrero 230 kV Switchyard (“Potrero Switchyard”) to a new CCSF’s 230 kV Substation being constructed by CCSF (“Davidson Substation”), described in Exhibit A attached to this Transmission Facilities Agreement (“TFA”).

This TFA, inclusive of its Exhibits, which are identified herein, is entered into to support CCSF’s proposed Potrero Switchyard 230 kV Interconnection Project (“Potrero 230 kV Interconnection”) pursuant to the CCSF Transmission Interconnection Agreement (“CCSF TIA”) under Service Agreement No. 284 and is subject to all terms and conditions thereof. For purposes of interpreting this TFA, if any term or condition of this TFA conflicts with the CCSF TIA, this TFA shall govern.

All capitalized terms not defined herein, are defined in the CCSF TIA.

1. CCSF’s Interconnection Facilities

CCSF’s Interconnection Facilities (“CCSF Facilities”) shall consist of the following equipment, all of which will be owned, operated, repaired, maintained and replaced by CCSF:

- (a) CCSF’s Davidson Substation and all equipment located within Davidson Substation;

- (b) CCSF's duct bank extending to the Potrero Switchyard property line where it will meet PG&E's duct bank;
- (c) Metering units and required communication and telemetry devices, per CAISO requirements;
- (d) The 230 kV cable between CCSF's Davidson Substation and PG&E's Potrero Switchyard property line ("CCSF Cable") where it will meet PG&E's 230 kV cable at the point of the interconnection;
- (e) The relays in the Davidson Substation, including related line protection and telecommunication equipment, which is currently contemplated to consist of:
 - 230 kV primary line relay – (an SEL-411L Relay),
 - 230 kV backup line relay – (an SEL-411L Relay); and
- (e) Fiber optic cables between the two stations required for line tripping and the Remote Terminal Unit ("RTU") communication between PG&E and CCSF.

2. PG&E's Upgrades and Direct Assignment Interconnection Facilities

PG&E will construct Potrero Switchyard 230 kV Interconnection Facilities ("PG&E Facilities") at CCSF's cost to accommodate CCSF's interconnection request. The PG&E Facilities described below are Direct Assignment Facilities, as defined in TIA, and will be owned, maintained, operated, repaired and replaced by PG&E to serve CCSF except the PG&E Cable which will be repaired and replaced by CCSF. These PG&E Facilities are all Direct Assignment Facilities, as defined in TIA, for the sole use and benefit of CCSF:

- (a) A new 230 kV line position with two 230 kV breakers in a breaker-and-a-half circuit configuration located at PG&E's Potrero Switchyard;
- (b) Protection equipment in PG&E's Potrero Switchyard;

- (c) To the extent necessary, SF Remedial Action Scheme (“SFRAS”) equipment for the new CCSF Cable and circuit breakers;
- (d) 230 kV line switch at PG&E’s Potrero Switchyard for the CCSF Cable;
- (e) 230 kV line terminations located in the basement of PG&E’s Potrero Gas Insulated Substation (“GIS”)/Modular Protection Automation and Control (“MPAC” Building);
- (f) The 230 kV cable between the 230 kV line terminations located inside the Potrero Switchyard and PG&E’s Potrero Switchyard property line (“PG&E Cable”).
- (g) Foundation for the 230 kV line terminations located in the basement of PG&E’s Potrero GIS/MPAC Building;
- (h) Conduit duct bank from basement of PG&E’s Potrero GIS/MPAC Building to PG&E’s Potrero Switchyard property line; and
- (i) New System Control and Data Acquisition Remote Terminal Unit to provide circuit breaker information to CCSF.

3. Engineering Agreement and Procurement Agreement

The Parties previously entered into an Engineering Agreement that was filed with FERC, in FERC Docket No. ER18-2207-000, accepted on August 14, 2018, as amended.

The Parties previously entered into a Procurement Agreement that was filed with FERC, in FERC Docket No. ER20-138-000, accepted on October 21, 2019, as amended.

The Engineering Agreement and the Procurement Agreement will terminate when this TFA is accepted by FERC. This TFA incorporates all the costs and work that PG&E performed under that Engineering Agreement and Procurement Agreement.

4. This TFA includes and incorporates:

Exhibit A: Interconnection Facilities and Ownership Schematic

Exhibit B: Detail of Estimated Direct Assignment Facilities Charges

Exhibit B-1: Description of Direct Assignment Facilities

5. Operational Considerations

- 5.1 CCSF shall maintain and perform its own Under Frequency Load Shedding program.
- 5.2 Pursuant to this TFA, PG&E agrees to construct a 230 kV interconnection to Davidson Substation that shall serve a maximum capacity of no more than 68 MW and with a power factor of 0.97 based on the latest study report. If CCSF requires additional capacity, it must apply for such additional capacity in advance.

Consistent with Section 11.2 of the TIA, due to safety and reliability concerns, CCSF shall not interconnect any electric generating facility directly or indirectly to CCSF's Electric System served from CCSF's 230 kV Davidson Substation that would operate in 'parallel' mode with the PG&E Electric System without PG&E's prior written approval. To obtain such approval, CCSF shall submit an interconnection request to PG&E so that the proposed generating unit will be studied to identify any potential impacts resulting from interconnection of such generation. CCSF will be responsible for all study costs (i.e., System Impact Studies followed by Facilities Studies, if necessary, according to the Transmission Owner Tariff, FERC Electric Tariff Volume No. 5) and equipment and installation costs associated with all facilities and modifications required by the study. Interconnection of generators will not be permitted until CCSF completes installation of all equipment required by the study and receives written confirmation from PG&E that the installation is complete and consistent with PG&E's Transmission Interconnection Handbook and Good Utility Practice.

- 5.3 Maintenance and Emergency Conditions

Pursuant to TIA Section 10, PG&E is not responsible for power outages during maintenance and emergency conditions. PG&E will provide CCSF a minimum of 96 hours notice prior to performing any scheduled work on the breaker at Potrero Switchyard.

5.4 Future Upgrades

Consistent with Section 9.3 of the TIA, CCSF shall upgrade CCSF Facilities to match corresponding PG&E upgrades at CCSF's cost to the extent necessary to ensure continued and reliable service. Pursuant to Section 9.3 of the CCSF TIA, the Parties shall coordinate their efforts pertaining to upgrades and provide as much advance notice to the other Party as is reasonably possible.

5.5 CCSF Work Inside Potrero Switchyard

- (a) CCSF Contractors/Personnel will be performing work in the Potrero Switchyard to pull and terminate the CCSF Cable. CCSF Contractors/Personnel entering the Potrero Switchyard must complete a safety orientation and pass any exams necessary to meet PG&E's current safety requirements and NERC compliance standard requirements in order to perform such work.
- (b) In the future, when necessary to perform repair work on the CCSF Cable and the PG&E Cable and terminations, PG&E will grant supervised/escorted access to CCSF provided that CCSF Contractors/Personnel satisfy PG&E's requirements for access to the Potrero Switchyard. Such requirements include, but are not limited to the then current NERC, NERC CIP, and CPUC requirements for entry into such a low impact CIP site. The Parties recognize that the CIP classification of Potrero Switchyard may change and NERC, NERC CIP, and CPUC requirements may change. The Parties will develop procedures to address these changes in the future such that CCSF will be able to maintain and

repair/replace the CCSF Cable and to repair/replace the PG&E Cable and terminations.

- (c) PG&E will be responsible for the maintenance of the PG&E Cable and terminations. . CCSF will be responsible for the repair or replacement of the PG&E Cable and terminations. . CCSF Contractors/Personnel will be given supervised access into Potrero Switchyard for this purpose, as discussed above.

6. Within thirty (30) business days, Customer shall pay PG&E the amount set forth in Exhibit B, Section II, including an initial charge (“Initial Charge”) equal to the sum of the estimated amounts identified in subsections A-F of Exhibit B, Section II, subject to true-up as provided in Section 7 of this TFA. The Parties have agreed that, on an as-needed basis, following receipt of the Initial Charge PG&E may invoice CCSF for additional project-related costs and charges when the actual cost exceeds 10% or more of the Initial Charge, and CCSF shall pay all invoices in accordance with Section 14 of the CCSF TIA within thirty (30) business days. A failure by CCSF to pay any invoices for additional project-related costs and charges exceeding the Initial Charge will result in PG&E stopping work until it receives payment.
7. PG&E shall determine the actual cost of installing the PG&E Facilities and shall provide Customer a final accounting within one-hundred eighty (180) calendar days of energization of the PG&E Facilities identified in the Description of Facilities, attached hereto as Exhibit B-1. If the actual cost of the identified project is greater than the total amount that has been paid by Customer, then PG&E shall bill, and Customer shall pay for the remaining, including interest determined pursuant to Section 35.19(a) of the Federal Energy Regulatory Commission’s (FERC’s or Commission’s) Regulations, 18 CFR § 35.19(a) within thirty (30) business days. If the actual cost is less than the total amount that has been paid by Customer, then PG&E shall reimburse Customer the difference, including interest determined pursuant to Section 35.19(a) of FERC’s Regulations, 18 CFR § 35.19(a) within thirty (30) business days.

8. Where, as in this case, Customer has requested and PG&E has provided facilities, Customer also shall pay PG&E any applicable monthly rates and charges, plus an ownership charge, as specified in Sections III or IV of Exhibit B to this TFA:

Section III: A Cost-of-Ownership Charge representing PG&E's continuing monthly cost of owning, operating and maintaining the PG&E Facilities; or

Section IV: An Equivalent One-Time Charge equal to the present value of the monthly Cost-of-Ownership Charge in perpetuity.

The Cost-of-Ownership Charge shall commence on the date PG&E Facilities are first available for Customer's use, as such date is established in PG&E's records. PG&E will notify Customer, in writing, of such commencement date. The Equivalent One-Time Charge (if applicable) shall be payable by Customer to PG&E within 30 business days from receipt of an invoice from PG&E.

9. The Cost-of-Ownership Charge for interconnections provided under this TFA is determined by PG&E in accordance with PG&E's applicable percentage rates, which are calculated using PG&E's most recent transmission owner revenue requirement on file with and accepted by FERC. PG&E charges the following Cost-of-Ownership rates for transmission facilities: Customer-financed, transmission-level rate = 0.38% of the project facilities costs monthly; and PG&E-financed, transmission-level rate = 1.20% of the project facilities costs monthly. Either Party may apply unilaterally for a change in rate pursuant to Section 33 of the CCSF TIA.
10. To the extent that it becomes necessary to install facilities on Customer's premises, PG&E and Customer shall make arrangements such that PG&E:
 - (a) Is given escorted access such that it can perform installation on Customer's premises along the shortest practical route thereon with sufficient legal clearance from all structures above and below ground now or hereafter erected or installed on Customer's premises; and

- (b) Has escorted ingress and egress from Customer's premises at all reasonable hours for any purposes reasonably connected with the installation, operation and maintenance of PG&E facilities.
11. When formal rights of way, easements or special use permits are required on or over Customer's property or the property of third parties for the installation of facilities, Customer agrees that PG&E shall use all reasonable efforts to obtain such rights of way, easements or special use permits, which shall be obtained at Customer's expense or, if Customer and PG&E agree, Customer shall obtain any necessary permanent rights of way, easements or special use permits, satisfactory to and without cost to PG&E. To the extent that modification is required of other agreements between Customer and PG&E regarding current or planned transmission projects in the vicinity of or impacted by the CCSF Facilities or PG&E Facilities to be installed in connection with this TFA, Customer and PG&E shall make good faith efforts to agree on such modifications, recognizing that such modifications may be a necessary element of the overall scheme of generation and transmission facilities sought to be installed by PG&E and also recognizing that PG&E has already expended effort and costs to fulfill such other agreements.
12. PG&E shall not be responsible for any reasonable delay in completion of the installation of PG&E Facilities resulting from shortage of labor or materials, pandemics, strike, labor disturbance, cyber attack, war, riot, weather conditions, governmental rule, regulation or order, including orders or judgments of any court or regulatory agency, delay in obtaining necessary rights of way, special use permits and easements, acts of God, delays resulting from PG&E's responsibility to coordinate certain electric interconnections or modifications with the California Independent System Operator Corporation, or any other cause or condition beyond the control of PG&E. Moreover, PG&E shall not be liable for any direct, incidental, indirect, special, punitive, or consequential damages resulting from such delay. PG&E shall have the right, if for one of the above reasons it is unable to obtain materials or labor for all of its construction requirements, to allocate materials and labor to construction projects which it deems, in its sole discretion, most important to serve the

needs of its customers, and any delay in construction, hereunder resulting from such allocation shall be deemed to be a cause beyond PG&E's control. In any event, PG&E's total liability for any delay in the completion of the installation of PG&E Facilities shall not exceed the Initial Charge paid by Customer.

13. New electric extensions and connections, capacity upgrades to existing facilities, conduits and substructures, and the maintenance of facilities, conduits and substructures provided under this TFA shall be installed and made in accordance with fundamental design, installation, ownership, and maintenance provisions of Applicable Requirements and Good Utility Practice as defined in Sections 4.3 and 4.19, respectively, and as described in Section 10, General Interconnection Requirements, of the CCSF TIA. Interconnection facilities for points of interconnection at transmission voltage shall be installed, operated and maintained in accordance with PG&E's then-current Transmission Interconnection Handbook. All charges, payments and refunds shall be made solely under the provisions of this TFA.
14. If PG&E is prevented from completing the installation of PG&E Facilities for reasons beyond its reasonable control after twelve (12) months following the date of this TFA, PG&E shall have the right to supersede the applicable Exhibit or Exhibits to this TFA to reflect cost changes upon at least thirty (30) calendar days' written notice to Customer. PG&E shall have the right to adjust any amounts required to be paid by Customer hereunder that may be due based on that portion of the PG&E Facilities then completed, if any, utilizing the estimated costs developed by PG&E for the applicable Exhibit or Exhibits to this TFA. Such superseding Exhibit or Exhibits shall be in substantially the same form as the then-existing Exhibit or Exhibits to this TFA and must be approved in writing by the Parties hereto. If Customer does not approve the superseding Exhibit or Exhibits within thirty (30) business days of delivery of PG&E's notice, the original Exhibit or Exhibits to this TFA shall terminate, and the payment provisions of Section 17 herein shall be applied to that portion of PG&E Facilities then completed, even if the TFA itself has not been terminated. Customer also shall reimburse PG&E for any actual documented expenses

PG&E may have incurred for engineering, surveying, right of way acquisition and other work associated with that portion of PG&E Facilities not installed.

15. This TFA shall become effective on the later of (1) **February 1, 2021** or (2) when it is accepted for filing and permitted to become effective by the Federal Energy Regulatory Commission. Except as provided for in Section 12 herein, this TFA shall remain in force and for the duration of the existing CCSF TIA or until one of the following events occurs:
- (a) Customer fails to make timely payment for the Initial Charge and any additional costs or charges invoiced by PG&E pursuant to Section 6 of this TFA. PG&E has the right to immediately cease work in the event of non-payment; or
 - (b) Customer or its successor, terminates this TFA without a FERC-approved replacement agreement; or
 - (c) Customer fails to pay the monthly Cost-of-Ownership Charge prescribed in the TFA Exhibit B and described in Sections 8 and 9 of this TFA;
 - (d) The CCSF TIA is terminated without a FERC-approved replacement agreement; or
 - (e) The Parties agree in writing to terminate this TFA.

PG&E shall provide Customer at least thirty (30) business days' written notice of termination pursuant to subpart (a) or (c) and a reasonable opportunity to cure (if appropriate) before termination becomes effective pursuant to this Section 16.

16. Upon termination of the TFA for any reason:

- (a) Customer shall pay to PG&E a facilities termination charge, defined as the estimated removal cost, less the estimated salvage value for any Facilities that can be removed, all as determined by PG&E in accordance with its standard accounting practices. PG&E shall deduct the unused Initial Charge from the facilities termination charge. Any credits with regard to the unamortized balance of the Equivalent One-Time Charge previously paid, if any, will be negotiated by the

Parties. If the Initial Charge paid is greater than the facilities termination charge, PG&E shall refund the difference, without interest to Customer within a reasonable time.

- (b) PG&E shall be entitled to remove and shall have a reasonable time in which to remove, any portion of the facilities located on Customer's premises.
 - (c) Pursuant to FERC's rules and regulations, PG&E will make a filing and obtain FERC acceptance prior to billing Customer for any facilities termination charge.
17. Nothing contained herein shall be construed as affecting in any way the right of PG&E to unilaterally make application to FERC for a change in rates, including terms and conditions, under Section 205 of the Federal Power Act ("FPA") and pursuant to FERC's Rules and Regulations promulgated thereunder. Nothing contained herein shall be construed as affecting in any way CCSF's rights under Section 206 of the FPA.
18. No transfer or assignment of either Party's rights, benefits or duties under this TFA shall be effective without the prior written consent of the other Party, which consent shall not be withheld unreasonably; provided, however, that this Section 18 shall not apply to interests that arise by reason of any deed of trust, mortgage, indenture or security agreement granted or executed by either Party. No partial assignment of either Party's rights, benefits or duties shall be permitted under this TFA unless otherwise agreed in writing to by the Parties. Any successor to or transferee or assignee of the rights or obligations of a Party, whether by voluntary transfer, judicial sale, foreclosure sale or otherwise, shall be subject to all terms and conditions of this TFA to the same extent as though such successor, transferee, or assignee were an original party.

19. Liability and Indemnity

Section 25 of the CCSF TIA (Indemnity) and Section 26 of the CCSF TIA (Liability) shall apply to this TFA.

20. In no event shall either Party hereto or any subcontractor be liable for indirect, special, incidental, consequential or exemplary damages, including but not limited to, the loss of profits or revenue, loss of use of the equipment or any associated equipment, cost of capital, cost of substitute equipment, facilities or services, down time costs, costs in excess of estimates, loss of opportunity, loss of data, loss of goodwill or claims of customers of the other Party for such damages, and each Party hereby releases each other Party there from. Any dispute arising from this TFA shall be resolved in accordance with Appendix A of the CCSF TIA.
21. Customer's liability for the Income Tax Component of Contribution ("ITCC") under this TFA shall equal the product of (i) the gross income realized by PG&E for income tax purposes with respect to the payments or property transfers made by Customer to PG&E under this TFA for the construction of PG&E Facilities multiplied by (ii) the "Gross-up Percentage" (as defined below). The "Gross-up Percentage" shall equal the gross-up percentage determined in accordance with "method 5," as described in CPUC Decision 87-09-026 for taxable contributions-in-aid-of-construction paid to PG&E in the year the Gross Income Amount is includable in PG&E's taxable income. The "Gross-up Percentage" shall be presumed to be the percentage set forth in PG&E's electric tariffs accepted by the CPUC for taxable contributions in aid of construction.
22. This TFA may be executed in any number of counterparts, each of which shall be an original and all of which together shall constitute one instrument.
23. This TFA may be amended or modified only by the written agreement of the Parties, except as otherwise specifically provided herein.
24. This TFA, inclusive of its exhibits and, by reference, the CCSF TIA, constitutes the complete and final expression of the rights and obligations of the Parties in connection with the subject matter of this TFA and is intended as a complete and exclusive statement of the terms of their agreement which supersedes all prior and contemporaneous offers, promises, representations, negotiations, discussions, communications, and contracts which may have been made in connection with the subject matter of this TFA. The exhibits to this TFA, as

they may be revised from time to time by written agreement of the Parties, are attached to this TFA and are incorporated by reference as if herein fully set forth.

IN WITNESS WHEREOF, the Parties have caused this Agreement to be executed this 1st day of February, 2021 but effective as set forth above.

CITY AND COUNTY OF SAN FRANCISCO

Print Name: _____

Signature: _____

Title: _____

Date: _____

PACIFIC GAS AND ELECTRIC COMPANY

Print Name: _____

Signature: _____

Title: _____

Date: _____

Attachments:

TFA Exhibit A Interconnection Facilities and Ownership Schematic

TFA Exhibit B Detail of Estimated Direct Assignment Facilities Charges

DRAFT

EXHIBIT A

INTERCONNECTION FACILITIES AND OWNERSHIP SCHEMATIC

Potrero 230 kV Switchyard

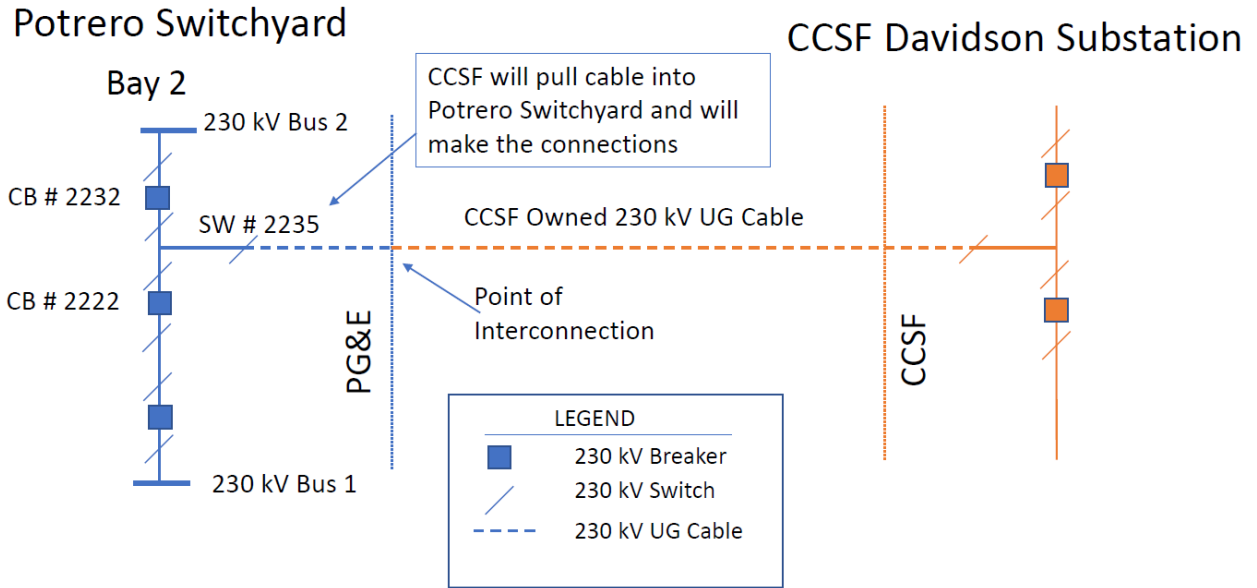

EXHIBIT B

DETAIL OF ESTIMATED DIRECT ASSIGNMENT FACILITIES CHARGES

I. Applicability

The application of charges specified herein as Direct Assignment Facilities, as defined in TIA, is pursuant to the provisions of this TFA between CCSF and PG&E and shall be a part thereof and in effect until superseded by mutual agreement.

II. Initial Estimated Charges

A.	Net Cost of PG&E Facilities (see Exhibit B-1)	\$15,000,000.00	
	ITCC ¹ (24%)	\$3,600,000.00	
	Including Engineering Agreement Phase 1 Payment ITCC (\$420,000.00) and Procurement Agreement Payment ITCC (\$720,000.00)		
	Total Cost of PG&E Facilities (including ITCC, see Exhibit B-1)		\$18,600,000.00
B.	Less the cost of “removable and reusable” facilities which are provided, installed, financed, and furnished by PG&E		\$0.00
C.	Less PG&E’s estimate of the total cost of facilities provided and installed by Customer (excluding costs of design and administration by PG&E)		\$0.00

¹ For a project of this magnitude, the ITCC rate is generally assessed at the time the facilities are put into service. The current rate of 24% is shown for illustrative purposes only. The then-current ITCC rate will be used at the time that the project is completed and put into service.

D.	Engineering Agreement Phase 1 Payment on 08/15/2018	(\$1,750,000.00)	
	Procurement Agreement Payment on 10/18/2019	(\$3,000,000.00)	
	Less total credit for customer advance funding (excluding ITCC)		(\$4,750,000.00)
E.	Plus Rearrangement Charge		\$0.00
F.	Initial Estimated Charge (including ITCC)		\$13,850,000.00

III. Estimated Monthly Cost of Ownership Charge

Facilities Financed By:	Application Base	Cost	Current Percentage Rate	Monthly Charge
A. Customer	Net Cost of Direct Assignment Facilities (II.A. above)			
	1. Estimated cost of Direct Assignment Facilities installed by PG&E	\$15,000,000		
	2. Estimated cost of Direct Assignment Facilities installed by Customer and deeded to PG&E	\$0		
	3. Less allowance for existing facilities	\$0		
	4. Net amount	\$15,000,000	$\times 0.38\% / \text{mo}$	$= \$57,000.00 / \text{mo}$

² The current FERC transmission customer-financed monthly Cost of Ownership rate. The then-current Cost of Ownership rate will be used at the time that the project is completed and put into servi

B. PG&E	Existing facilities allocated as Facilities (III. Above = 2. below)			
	1. Transmission Facilities	\$0	× \$0 / mo	= \$0 / mo
	Total Estimated Monthly COST-OF-OWNERSHIP CHARGE			= \$57,000.00 / mo

IV. Equivalent of One Time Charge (in lieu of monthly Cost-of-Ownership Charge).

$$\$57,000 \times 12 \text{ months} \times 14.73^3 \text{ years} = \$10,075,320.00$$

DRAFT

³ The current Present Worth Factor rate is 14.73. The then-current Present Worth Factor rate will be used at the time that the project is completed and put into service.

**EXHIBIT B-1:
DESCRIPTION OF DIRECT ASSIGNMENT FACILITIES**

INSTALLATION OF THE PG&E FACILITIES

WORK ITEM	COST	COST
SUBSTATION WORK		
This includes the necessary upgrades to PG&E's substation equipment, protection system, relays, telecommunications equipment, and other substation equipment at the Potrero Switchyard.		
(a) Engineering	\$2,000,000	
(b) Project Management	\$1,500,000	
(c) Property Improvements	\$750,000	
(d) Station Equipment and Labor	\$3,500,000	
(e) Removal	\$50,000	
(f) Telecommunications	\$150,000	
(g) Testing	\$1,300,000	
(h) Maintenance & Operations	\$500,000	
(i) Land & Environmental	\$250,000	
(j) Contract & Various Group Support	\$5,000,000	
Total Substation Work		\$15,000,000
FACILITIES WORK INSTALLED BY CUSTOMER AND DEDED TO PG&E		\$0
Less PG&E's estimate of the total cost of facilities provided, installed and dedeed to PG&E by Customer (excluding costs of design and administration by PG&E)		\$0
TOTAL DIRECT ASSIGNMENT FACILITIES		\$15,000,000

PUBLIC UTILITIES COMMISSION

City and County of San Francisco

RESOLUTION NO. 21-0010

WHEREAS, San Francisco Public Utilities Commission (SFPUC) Power Enterprise is planning the design and construction of a new 230 kilovolt (kV) interconnection from the Pacific Gas and Electric Company (PG&E) Potrero 230 kV Switchyard (“Potrero Switchyard”) to a new CCSF 230 kV Substation being constructed by CCSF (“Davidson Substation”) to allow SFPUC to deliver 100% GHG-free energy from Hetch Hetchy to its customers; and

WHEREAS, In order for PG&E to construct improvements at the Potrero Switchyard that are necessary for SFPUC to deliver electricity to the customers through BCTD, SFPUC must enter into a Transmission Facilities Agreement (TFA) with PG&E; and

WHEREAS, The estimated cost of the services to be provided under the TFA is \$18,600,000, plus \$57,000 per month to cover PG&E’s cost of ownership; and

WHEREAS, The total contracting authority sought herein is \$18,600,000, which reflects a 10% contingency to account for any unforeseen events in PG&E’s cost estimate; and

WHEREAS, Funding for the TFA is available from project 10014227 – Bay Corridor Project for a one-time cost of \$18,600,000 and monthly costs of \$57,000 will be paid from the Hetch Hetchy operating budget; and

WHEREAS, The TFA has a five year initial term, which staff expects to be extended; and

WHEREAS, On October 24, 2019, the Planning Department determined that the construction of the new Davidson Substation and connection to the PG&E Potrero 230 kV Switchyard is categorically exempt under the California Environmental Quality Act (CEQA) Guidelines Section 15303 (Class 3 New Construction or Conversion of Small Structures); and

WHEREAS, Funds for the TFA will be available at the time of award of the agreement from Project No. 10014227 - Bay Corridor Project; now, therefore, be it

RESOLVED, That this Commission hereby authorizes the General Manager of the San Francisco Public Utilities Commission to execute a Transmission Facilities Agreement with Pacific Gas and Electric Company to furnish and construct a new 230 kilovolt (kV) interconnection from the PG&E Potrero 230 kV Switchyard to the new CCSF 230 kV Substation being constructed by SFPUC, substantially in the form of the draft agreement attached to this Resolution, with an amount not-to-exceed \$18,600,000, plus monthly cost of ownership charges of \$57,000, and for the initial five-year term of the TFA; and be it

FURTHER RESOLVED, That this Commission authorizes the General Manager to approve necessary changes to the Transmission Facilities Agreement that he or she determines, in consultation with the City Attorney, do not materially alter the balance of benefits and burdens to the City from the Agreement and to direct SFPUC staff to take actions necessary to implement the Agreement; and be it,

FURTHER RESOLVED, That this Commission authorizes the General Manager to submit the agreement to the Board of Supervisors for its review and approval, pursuant to Charter Section 9.118.

I hereby certify that the foregoing resolution was adopted by the Public Utilities Commission at its meeting of January 26, 2021.

A handwritten signature in black ink that reads "Alonna Wood". The signature is written in a cursive, flowing style.

Secretary, Public Utilities Commission

**TRANSMISSION FACILITIES AGREEMENT
BETWEEN
CITY AND COUNTY OF SAN FRANCISCO
AND
PACIFIC GAS AND ELECTRIC COMPANY**

Potrero Switchyard 230 kV Interconnection Project

At the request of City and County of San Francisco (“Customer” or “CCSF”), Pacific Gas and Electric Company (“PG&E”), a California corporation (collectively, “Parties”), agrees to furnish and construct, at the Customer’s expense, a new 230 kV interconnection from the PG&E Potrero 230 kV Switchyard (“Potrero Switchyard”) to a new CCSF’s 230 kV Substation being constructed by CCSF (“Davidson Substation”), described in Exhibit A attached to this Transmission Facilities Agreement (“TFA”).

This TFA, inclusive of its Exhibits, which are identified herein, is entered into to support CCSF’s proposed Potrero Switchyard 230 kV Interconnection Project (“Potrero 230 kV Interconnection”) pursuant to the CCSF Transmission Interconnection Agreement (“CCSF TIA”) under Service Agreement No. 284 and is subject to all terms and conditions thereof. For purposes of interpreting this TFA, if any term or condition of this TFA conflicts with the CCSF TIA, this TFA shall govern.

All capitalized terms not defined herein, are defined in the CCSF TIA.

1. CCSF’s Interconnection Facilities

CCSF’s Interconnection Facilities shall consist of the following equipment, all of which will be owned, operated, repaired, maintained and replaced by CCSF:

- (a) CCSF’s Davidson Substation and all equipment located within Davidson Substation;

- (b) CCSF's duct bank extending to the Potrero Switchyard property line where it will meet PG&E's duct bank;
- (c) Metering units and required communication and telemetry devices, per CAISO requirements;
- (d) The 230 kV cable between CCSF's Davidson Substation ("CCSF Cable") and PG&E's Potrero Switchyard property line where it will meet PG&E's 230 kV cable ("Point of Interconnection");
- (e) The relays in the Davidson Substation, including related line protection and telecommunication equipment, which is currently contemplated to consist of:
 - 230 kV primary line relay – (an SEL-411L Relay),
 - 230 kV backup line relay – (an SEL-411L Relay); and
- (e) Fiber optic cables between the two stations required for line tripping and the Remote Terminal Unit ("RTU") communication between PG&E and CCSF.

2. PG&E's Interconnection Facilities

PG&E will construct Potrero Switchyard 230 kV Interconnection Facilities ("PG&E Facilities") at CCSF's cost to accommodate CCSF's interconnection request. The PG&E Facilities described below are Direct Assignment Facilities, as defined in TIA, and will be owned, maintained, operated, repaired and replaced by PG&E to serve CCSF.

- (a) A new 230 kV line position with two 230 kV breaker-and-a-half (BAAH) circuit breakers located at PG&E's Potrero Switchyard;
- (b) Protection equipment in PG&E's Potrero Switchyard;
- (c) To the extent necessary, SF Remedial Action Scheme ("SFRAS") equipment for the new CCSF Cable and circuit breakers;

- (d) 230 kV line switch at PG&E's Potrero Switchyard for the CCSF Cable;
- (e) 230 kV line terminations located in the basement of PG&E's Potrero Gas Insulated Substation ("GIS")/Modular Protection Automation and Control ("MPAC" Building);
- (f) Foundation for the 230 kV line terminations located in the basement of PG&E's Potrero GIS/MPAC Building;
- (g) Conduit duct bank from basement of PG&E's Potrero GIS/MPAC Building to PG&E's Potrero Switchyard property line; and
- (h) New System Control and Data Acquisition Remote Terminal Unit to provide circuit breaker information to CCSF.

3. Engineering Agreement and Procurement Agreement

The Parties previously entered into an Engineering Agreement that was filed with FERC, in FERC Docket No. ER18-2207-000, accepted on August 14, 2018, as amended.

The Parties previously entered into a Procurement Agreement that was filed with FERC, in FERC Docket No. ER20-138-000, accepted on October 21, 2019, as amended.

The Engineering Agreement and the Procurement Agreement will terminate when this TFA is accepted by FERC. This TFA incorporates all the costs and work that PG&E performed under that Engineering Agreement and Procurement Agreement.

4. This TFA includes and incorporates:

Exhibit A: Interconnection Facilities and Ownership Schematic

Exhibit B: Detail of Facilities Charges

Exhibit B-1: Description of Facilities

5. Operational Considerations

- 5.1 CCSF shall maintain and perform its own Under Frequency Load Shedding program.
- 5.2 Pursuant to this TFA, PG&E agrees to construct a 230 kV interconnection to Davidson Substation that shall serve a maximum capacity of no more than 68 MW and with a power factor of 0.97 based on the latest study report. If CCSF requires additional capacity, it must apply for such additional capacity in advance.

Consistent with Section 11.2 of the TIA, due to safety and reliability concerns, CCSF shall not interconnect electric generating facility directly to CCSF's Electric Primary 12 kV Distribution System served from CCSF's 230 kV Davidson Substation that would operate in 'parallel' mode with the PG&E Electric System without PG&E's prior written approval. To obtain such approval, CCSF shall submit an interconnection request to PG&E so that the proposed generating unit will be studied to identify any potential impacts resulting from interconnection of such generation. CCSF will be responsible for all study costs (i.e., System Impact Studies followed by Facilities Studies, if necessary, according to the Transmission Owner Tariff, FERC Electric Tariff Volume No. 5) and equipment and installation costs associated with all facilities and modifications required by the study. Interconnection of generators will not be permitted until CCSF completes installation of all equipment required by the study and receives written confirmation from PG&E that the installation is complete and consistent with PG&E's Transmission Interconnection Handbook and Good Utility Practice.

5.3 Maintenance and Emergency Conditions

Pursuant to TIA Section 10, PG&E is not responsible for power outages during maintenance and emergency conditions. PG&E will provide CCSF a minimum of 96 hours notice prior to performing any scheduled work on the breaker at Potrero Switchyard.

5.4 Future Upgrades

Consistent with Section 9.3 of the TIA, CCSF shall upgrade Davidson Substation facilities to match corresponding PG&E upgrades at CCSF's cost to the extent necessary to ensure continued and reliable service. Pursuant to Section 9.3 of the CCSF TIA, the Parties shall coordinate their efforts pertaining to upgrades and provide as much advance notice to the other Party as is reasonably possible.

5.5 CCSF Work Inside Potrero Switchyard

- (a) CCSF Contractors/Personnel will be performing work in the Potrero Switchyard to pull and terminate the 230 kV Cable.
- (b) CCSF Contractors/Personnel entering the Potrero Switchyard must complete a safety orientation and pass an exam with a score greater than 100% in order to perform the Work Inside Potrero Switchyard.
- (c) CCSF Contractors/Personnel must agree to meet all NERC and CIP protocols. The Parties will make an arrangement under which CCSF Contractors/Personnel will be permitted supervised access to Potrero Switchyard for purposes related to maintenance and repair of the 230 kV connection.
- (d) While the 230 kV cable located inside the Potrero Switchyard property line used to serve Davidson Substation will be owned by PG&E, any maintenance or repair will be CCSF's obligation. If the portion of the cable that is within Potrero Switchyard and owned by PG&E is damaged and needs to be repaired or replaced, it will be the obligation of CCSF to make such repairs or replacements. CCSF Contractors/Personnel will be given supervised access into Potrero Switchyard for this purpose.
- (a) CCSF Contractors/Personnel will be performing work in the Potrero Switchyard to pull and terminate the 230 kV Cable. CCSF Contractors/Personnel entering the Potrero Switchyard must complete a safety orientation and pass any exams necessary to meet PG&E's current

safety requirements and NERC compliance standard requirements in order to perform such work.

(b) In the future, when necessary to perform repair work on the CCSF installed 230 kV Cable, PG&E will grant supervised/escorted access to CCSF provided that CCSF Contractors/Personnel satisfy PG&E's requirements for access to the Potrero Switchyard. Such requirements include, but are not limited to the then current NERC, NERC CIP, and CPUC requirements for entry into such a low impact CIP site. The Parties recognize that the CIP classification of Potrero Switchyard may change and NERC, NERC CIP, and CPUC requirements may change. The Parties will develop procedures to address these changes in the future such that CCSF will be able to maintain and repair the 230 kV Cable.

(c) PG&E will be responsible for the maintenance of the cable located inside the Potrero Switchyard. While the 230 kV cable located inside the Potrero Switchyard property line used to serve Davidson Substation will be owned by PG&E, any repair or replacement will be CCSF's obligation. Therefore, if the portion of the cable that is within Potrero Switchyard and owned by PG&E is damaged and needs to be repaired or replaced, it will be the obligation of CCSF to make such repairs or replacements. CCSF Contractors/Personnel will be given supervised access into Potrero Switchyard for this purpose, as discussed above.

6. Within thirty (30) business days, Customer shall pay PG&E the amount set forth in Exhibit B, Section II, including an Initial Charge equal to the sum of the estimated amounts identified in subsections A-F of Exhibit B, Section II, subject to true-up as provided in Section 7 of this TFA. The Parties have agreed that, on an as-needed basis, following receipt of the Initial Charge PG&E may invoice CCSF for additional project-related costs and charges when the actual cost exceeds 10% or more of the Initial Charge, and CCSF shall pay all invoices in accordance with Section 14 of the CCSF TIA within thirty (30)

business days. A failure by CCSF to pay any invoices for additional project-related costs and charges exceeding the Initial Charge will result in PG&E stopping work until it receives payment.

7. PG&E shall determine the actual cost of installing the Facilities and shall provide Customer a final accounting within one-hundred eighty (180) calendar days of energization of the Facilities identified in the Description of Facilities, attached hereto as Exhibit B-1. If the actual cost of the identified project is greater than the total amount that has been paid by Customer, then PG&E shall bill, and Customer shall pay for the remaining, including interest determined pursuant to Section 35.19(a) of the Federal Energy Regulatory Commission's (FERC's or Commission's) Regulations, 18 CFR § 35.19(a) within thirty (30) business days. If the actual cost is less than the total amount that has been paid by Customer, then PG&E shall reimburse Customer the difference, including interest determined pursuant to Section 35.19(a) of FERC's Regulations, 18 CFR § 35.19(a) within thirty (30) business days.
8. Where, as in this case, Customer has requested and PG&E has provided Facilities, Customer also shall pay PG&E any applicable monthly rates and charges, plus an ownership charge, as specified in Sections III or IV of Exhibit B to this TFA:

Section III: A Cost-of-Ownership Charge representing PG&E's continuing monthly cost of financing (if PG&E has financed the facilities), owning, operating and maintaining Facilities; or

Section IV: An Equivalent One-Time Charge equal to the present value of the monthly Cost-of-Ownership Charge in perpetuity.

The Cost-of-Ownership Charge shall commence on the date Facilities are first available for Customer's use, as such date is established in PG&E's records. PG&E will notify Customer, in writing, of such commencement date. The Equivalent One-Time Charge (if applicable) shall be payable by Customer to PG&E within 30 business days from receipt of an invoice from PG&E.

9. The Cost-of-Ownership Charge for interconnections provided under this TFA is determined by PG&E in accordance with PG&E's applicable percentage rates, which are calculated using PG&E's most recent transmission owner revenue requirement on file with and accepted by FERC. PG&E charges the following Cost-of-Ownership rates for transmission facilities: Customer-financed, transmission-level rate = 0.38% of the project facilities costs monthly; and PG&E-financed, transmission-level rate = 1.20% of the project facilities costs monthly. Either Party may apply unilaterally for a change in rate pursuant to Section 33 of the CCSF TIA.
10. To the extent that it becomes necessary to install Facilities on Customer's premises, PG&E and Customer shall make arrangements such that PG&E:
 - (a) Is given escorted access such installation on Customer's premises along the shortest practical route thereon with sufficient legal clearance from all structures above and below ground now or hereafter erected or installed on Customer's premises; and
 - (b) Has escorted ingress and egress from Customer's premises at all reasonable hours for any purposes reasonably connected with the installation, operation and maintenance of Facilities.
11. When formal rights of way, easements or special use permits are required on or over Customer's property or the property of third parties for the installation of Facilities, Customer agrees that PG&E shall use all reasonable efforts to obtain such rights of way, easements or special use permits, which shall be obtained at Customer's expense or, if Customer and PG&E agree, Customer shall obtain any necessary permanent rights of way, easements or special use permits, satisfactory to and without cost to PG&E. To the extent that modification is required of other agreements between Customer and PG&E regarding current or planned transmission projects in the vicinity of or impacted by the Facilities to be installed in connection with this TFA, Customer and PG&E shall make good faith efforts to agree on such modifications, recognizing that such modifications may be a necessary element of the overall scheme of generation and transmission facilities sought to be

installed by PG&E and also recognizing that PG&E has already expended effort and costs to fulfill such other agreements.

12. PG&E shall not be responsible for any reasonable delay in completion of the installation of Facilities resulting from shortage of labor or materials, pandemics, strike, labor disturbance, cyber attack, war, riot, weather conditions, governmental rule, regulation or order, including orders or judgments of any court or regulatory agency, delay in obtaining necessary rights of way, special use permits and easements, acts of God, delays resulting from PG&E's responsibility to coordinate certain electric interconnections or modifications with the California Independent System Operator Corporation, or any other cause or condition beyond the control of PG&E. Moreover, PG&E shall not be liable for any direct, incidental, indirect, special, punitive, or consequential damages resulting from such delay. PG&E shall have the right, if for one of the above reasons it is unable to obtain materials or labor for all of its construction requirements, to allocate materials and labor to construction projects which it deems, in its sole discretion, most important to serve the needs of its customers, and any delay in construction, hereunder resulting from such allocation shall be deemed to be a cause beyond PG&E's control. In any event, PG&E's total liability for any delay in the completion of the installation of Facilities shall not exceed the Initial Charge paid by Customer.
13. New electric extensions and connections, capacity upgrades to existing facilities, conduits and substructures, and the maintenance of facilities, conduits and substructures provided under this TFA shall be installed and made in accordance with fundamental design, installation, ownership, and maintenance provisions of Applicable Requirements and Good Utility Practice as defined in Sections 4.3 and 4.19, respectively, and as described in Section 10, General Interconnection Requirements, of the CCSF TIA. Interconnection facilities for Points of Interconnection at transmission voltage shall be installed, operated and maintained in accordance with PG&E's then-current Transmission Interconnection Handbook. All charges, payments and refunds shall be made solely under the provisions of this TFA.

14. If PG&E is prevented from completing the installation of Facilities for reasons beyond its reasonable control after twelve (12) months following the date of this TFA, PG&E shall have the right to supersede the applicable Exhibit or Exhibits to this TFA to reflect cost changes upon at least thirty (30) calendar days' written notice to Customer. PG&E shall have the right to adjust any amounts required to be paid by Customer hereunder that may be due based on that portion of the Facilities then completed, if any, utilizing the estimated costs developed by PG&E for the applicable Exhibit or Exhibits to this TFA. Such superseding Exhibit or Exhibits shall be in substantially the same form as the then-existing Exhibit or Exhibits to this TFA, and must be approved in writing by the Parties hereto. If Customer does not approve the superseding Exhibit or Exhibits within thirty (30) business days of delivery of PG&E's notice, the original Exhibit or Exhibits to this TFA shall terminate, and the payment provisions of Section 17 herein shall be applied to that portion of Facilities then completed, even if the TFA itself has not been terminated. Customer also shall reimburse PG&E for any actual documented expenses PG&E may have incurred for engineering, surveying, right of way acquisition and other work associated with that portion of Facilities not installed.
15. This TFA shall become effective on the later of (1) [TBD], 2021 or (2) when it is accepted for filing and permitted to become effective by the Federal Energy Regulatory Commission. Except as provided for in Section 12 herein, this TFA shall remain in force and for the duration of the existing CCSF TIA or until one of the following events occurs:
- (a) Customer fails to make timely payment for the Initial Charge and any additional costs or charges invoiced by PG&E pursuant to Section 6 of this TFA. PG&E has the right to immediately cease work in the event of non-payment; or
 - (b) Customer or its successor, terminates this TFA without a FERC-approved replacement agreement; or
 - (c) Customer fails to pay the monthly Cost-of-Ownership Charge prescribed in the TFA Exhibit B and described in Sections 8 and 9 of this TFA;

- (d) The CCSF TIA is terminated without a FERC-approved replacement agreement; or
- (e) The Parties agree in writing to terminate this TFA.

PG&E shall provide Customer at least thirty (30) business days' written notice of termination pursuant to subpart (a) or (c) and a reasonable opportunity to cure (if appropriate) before termination becomes effective pursuant to this Section 16.

16. Upon termination of the TFA for any reason:

- (a) Customer shall pay to PG&E a Facilities Termination Charge, defined as the estimated removal cost, less the estimated salvage value for any Facilities that can be removed, all as determined by PG&E in accordance with its standard accounting practices. PG&E shall deduct the Initial Charge from the Facilities Termination Charge. Any credits with regard to the unamortized balance of the Equivalent One-Time Charge previously paid, if any, will be negotiated by the Parties. If the Initial Charge paid is greater than the Facilities Termination Charge, PG&E shall refund the difference, without interest to Customer within a reasonable time; and
 - (b) PG&E shall be entitled to remove, and shall have a reasonable time in which to remove, any portion of the Facilities located on Customer's premises.
 - (c) Pursuant to FERC's rules and regulations, PG&E will make a filing and obtain FERC acceptance prior to billing Customer for any Facilities Termination Charge.
17. Nothing contained herein shall be construed as affecting in any way the right of PG&E to unilaterally make application to FERC for a change in rates, including terms and conditions, under Section 205 of the Federal Power Act ("FPA") and pursuant to FERC's Rules and Regulations promulgated thereunder. Nothing contained herein shall be construed as affecting in any way CCSF's rights under Section 206 of the FPA.
18. No transfer or assignment of either Party's rights, benefits or duties under this TFA shall be effective without the prior written consent of the other Party, which consent shall not be

withheld unreasonably; provided, however, that this Section 18 shall not apply to interests that arise by reason of any deed of trust, mortgage, indenture or security agreement granted or executed by either Party. No partial assignment of either Party's rights, benefits or duties shall be permitted under this TFA unless otherwise agreed in writing to by the Parties. Any successor to or transferee or assignee of the rights or obligations of a Party, whether by voluntary transfer, judicial sale, foreclosure sale or otherwise, shall be subject to all terms and conditions of this TFA to the same extent as though such successor, transferee, or assignee were an original party.

19. Liability and Indemnity

Section 25 of the CCSF TIA (Indemnity) and Section 26 of the CCSF TIA (Liability) shall apply to this TFA.

20. In no event shall either Party hereto or any subcontractor be liable for indirect, special, incidental, consequential or exemplary damages, including but not limited to, the loss of profits or revenue, loss of use of the equipment or any associated equipment, cost of capital, cost of substitute equipment, facilities or services, down time costs, costs in excess of estimates, loss of opportunity, loss of data, loss of goodwill or claims of customers of the other Party for such damages, and each Party hereby releases each other Party there from. Any dispute arising from this TFA shall be resolved in accordance with Appendix A of the CCSF TIA.
21. Customer's liability for the Income Tax Component of Contribution ("ITCC") under this TFA shall equal the product of (i) the gross income realized by PG&E for income tax purposes with respect to the payments or property transfers made by Customer to PG&E under this TFA for the construction of Facilities multiplied by (ii) the "Gross-up Percentage" (as defined below). The "Gross-up Percentage" shall equal the gross-up percentage determined in accordance with "method 5," as described in CPUC Decision 87-09-026 for taxable contributions-in-aid-of-construction paid to PG&E in the year the Gross Income Amount is includable in PG&E's taxable income. The "Gross-up Percentage" shall

be presumed to be the percentage set forth in PG&E's electric tariffs accepted by the CPUC for taxable contributions in aid of construction.

22. This TFA may be executed in any number of counterparts, each of which shall be an original and all of which together shall constitute one instrument.
23. This TFA may be amended or modified only by the written agreement of the Parties, except as otherwise specifically provided herein.
24. This TFA, inclusive of its exhibits and, by reference, the CCSF TIA, constitutes the complete and final expression of the rights and obligations of the Parties in connection with the subject matter of this TFA and is intended as a complete and exclusive statement of the terms of their agreement which supersedes all prior and contemporaneous offers, promises, representations, negotiations, discussions, communications, and contracts which may have been made in connection with the subject matter of this TFA. The exhibits to this TFA, as they may be revised from time to time by written agreement of the Parties, are attached to this TFA and are incorporated by reference as if herein fully set forth.

IN WITNESS WHEREOF, the Parties have caused this Agreement to be executed this [TBD] day of [TBD], 2021 but effective as set forth above.

CITY AND COUNTY OF SAN FRANCISCO

Print Name: _____

Signature: _____

Title: _____

Date: _____

Draft November 17, 2020
CCSF edits, December 17, 2020
PG&E edits, December 23, 2020

PACIFIC GAS AND ELECTRIC COMPANY

Print Name: _____

Signature: _____

Title: _____

Date: _____

DRAFT

Draft November 17, 2020
CCSF edits, December 17, 2020
PG&E edits, December 23, 2020

Attachments:

- | | |
|------------------------|--|
| TFA Exhibit A | Interconnection Facilities and Ownership Schematic |
| TFA Exhibit B | Detail of Direct Assignment Facilities Charges |
| TFA Exhibit B-1 | Description of Facilities |

DRAFT

EXHIBIT A

INTERCONNECTION FACILITIES AND OWNERSHIP SCHEMATIC

Potrero 230 kV Switchyard

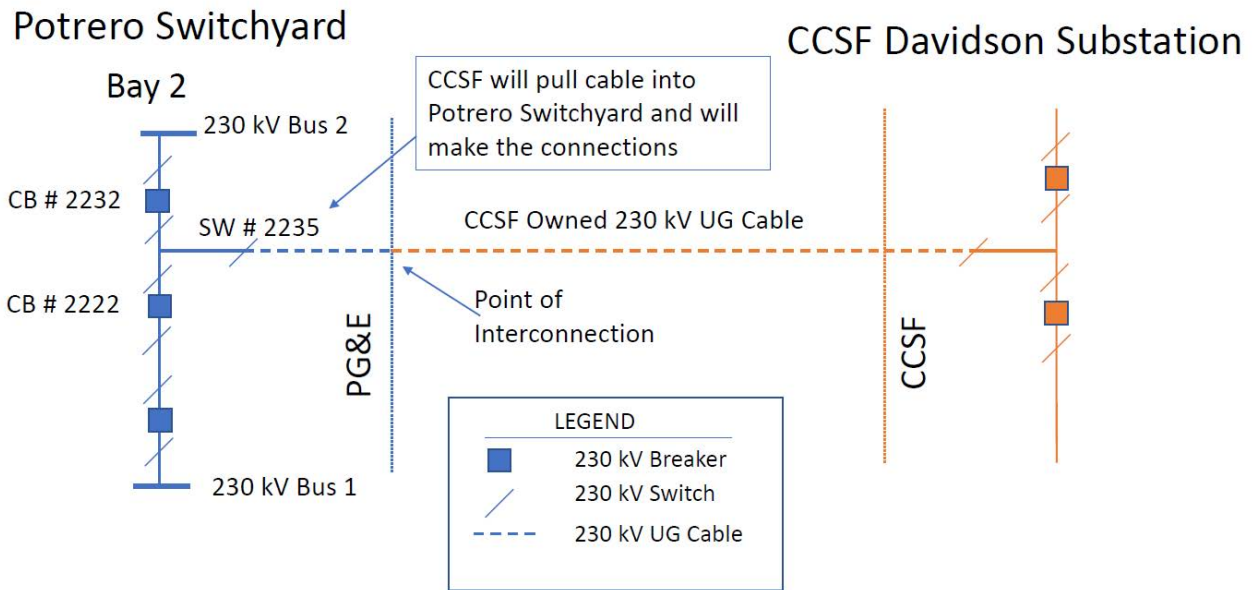

Draft November 17, 2020
CCSF edits, December 17, 2020
PG&E edits, December 23, 2020

DRAFT

EXHIBIT B

DETAIL OF ESTIMATED DIRECT ASSIGNMENT FACILITIES CHARGES

I. Applicability

The application of charges specified herein as Direct Assignment Facilities, as defined in TIA, is pursuant to the provisions of this TFA between CCSF and PG&E and shall be a part thereof and in effect until superseded by mutual agreement.

II. Initial Estimated Charges

A.	Net Cost of Facilities (see Exhibit B-1)	\$15,000,000.00	
	ITCC ¹ (24%) Including Engineering Agreement Phase 1 Payment ITCC (\$420,000.00) and Procurement Agreement Payment ITCC (\$720,000.00)	\$3,600,000.00	
	Total Cost of Facilities (including ITCC, see Exhibit B-1)		\$18,600,000.00
B.	Less the cost of “removable and reusable” Facilities which are provided, installed, financed, and furnished by PG&E		\$0.00
C.	Less PG&E’s estimate of the total cost of Facilities provided and installed by Customer (excluding costs of design and administration by PG&E)		\$0.00
D.			

¹ For a project of this magnitude, the ITCC rate is generally assessed at the time the facilities are put into service. The current rate of 24% is shown for illustrative purposes only. The then-current ITCC rate will be used at the time that the project is completed and put into service.

	Engineering Agreement Phase 1 Payment on 08/15/2018	(\$1,750,000.00)	
	Procurement Agreement Payment on 10/18/2019	(\$3,000,000.00)	
	Less total credit for customer advance funding (excluding ITCC)		(\$4,750,000.00)
E.	Plus Rearrangement Charge		\$0.00
F.	Initial Estimated Charge (including ITCC)		\$13,850,000.00

III. Estimated Monthly Cost of Ownership Charge

Facilities Financed By:	Application Base	Cost	Current Percentage Rate	Monthly Charge
A. Customer	Net Cost of Direct Assignment Facilities (II.A. above)			
	1. Estimated cost of Direct Assignment Facilities installed by PG&E	\$15,000,000		
	2. Estimated cost of Direct Assignment Facilities installed by Customer and deeded to PG&E	\$0		
	3. Less allowance for existing facilities	\$0		
	4. Net amount	\$15,000,000	$\times 0.38\% ^2 / \text{mo}$	$= \$57,000.00 / \text{mo}$

² The current FERC transmission customer-financed monthly Cost of Ownership rate. The then-current Cost of Ownership rate will be used at the time that the project is completed and put into service.

Draft November 17, 2020
 CCSF edits, December 17, 2020
 PG&E edits, December 23, 2020

B. PG&E	Existing facilities allocated as Facilities (III. Above = 2. below) 1. Transmission Facilities	\$0	× \$0 / mo	= \$0 / mo
	Total Estimated Monthly COST-OF-OWNERSHIP CHARGE			= \$57,000.00 / mo

DRAFT

EXHIBIT B-1:
DESCRIPTION OF DIRECT ASSIGNMENT FACILITIES

FACILITIES WORK INSTALLED BY PG&E

WORK ITEM	COST	COST
SUBSTATION WORK		
This includes the necessary upgrades to PG&E's substation equipment, protection system, relays, telecommunications equipment, and other substation equipment at the Potrero Switchyard.		
(a) Engineering	\$2,000,000	
(b) Project Management	\$1,500,000	
(c) Property Improvements	\$750,000	
(d) Station Equipment and Labor	\$3,500,000	
(e) Removal	\$50,000	
(f) Telecommunications	\$150,000	
(g) Testing	\$1,300,000	
(h) Maintenance & Operations	\$500,000	
(i) Land & Environmental	\$250,000	
(j) Contract & Various Group Support	\$5,000,000	
Total Substation Work		\$15,000,000
FACILITIES WORK INSTALLED BY CUSTOMER AND DEEDED TO PG&E		\$0
Less PG&E's estimate of the total cost of Facilities provided, installed and dedeed to PG&E by Customer (excluding costs of design and administration by PG&E)		\$0
TOTAL DIRECT ASSIGNMENT FACILITIES		\$15,000,000



TO: Angela Calvillo, Clerk of the Board

FROM: John Scarpulla, Policy and Government Affairs

DATE: February 2, 2021

SUBJECT: Transmission Facilities Agreement with Pacific Gas and Electric Company for a total cost of \$21,165,000 and a term of 4.5 years.

Please see attached a proposed Ordinance authorizing the San Francisco Public Utilities Commission to execute a Transmission Facilities Agreement (TFA) with PG&E for a term of 4.5 years and at a total cost of \$21,165,000.

The following is a list of accompanying documents:

- Proposed TFA Ordinance (Word Doc Version)
- Proposed TFA Ordinance (Signed PDF Version)
- Legislative Digest
- Draft TFA Contract Agreement

Please contact John Scarpulla at (415) 934-5782 or jscarpulla@sfgwater.org if you need any additional information on these items.

London N. Breed
Mayor

Sophie Maxwell
President

Anson Moran
Vice President

Tim Paulson
Commissioner

Ed Harrington
Commissioner

Michael Carlin
Acting
General Manager





SAN FRANCISCO PLANNING DEPARTMENT

CEQA CATEGORICAL EXEMPTION FORM

PROJECT NAME: SFPUC - 398 Quint Substation Project

PROJECT LOCATION: 398 Quint St, Bayview/Hunters Point

CASE NUMBER: 2019-013330ENV

PROJECT TYPE: New Facility Replacement Facility/Equipment
 Repair/Maintenance/Upgrade Other: _____

1. EXEMPTION CLASS

- Class 1: Existing Facilities
- Class 2: Replacement or Reconstruction
- Class 3: New Construction or Conversion of Small Structures
- Class 6: Information Collection
- Other: _____

2. CEQA Impacts

For any box checked below, refer to the attached Environmental Evaluation Application with supporting analysis and documentation.

- Air Quality:** Would the project affect sensitive receptors (specifically schools, colleges, universities, day care facilities, hospitals, residential dwellings, or senior-care facilities)? Would project construction or operations exceed air quality screening criteria using either the SFPUC Air Quality Screening Tool or CalEEMOD?
- Noise:** Would the project conflict with the applicable local Noise Ordinance?
- Hazardous Materials:** Would the project be located on a site included on any list compiled pursuant to Section 65962.5 of the Government Code, or impact an area with known hazardous materials such as a former gas station, auto repair, dry cleaners, heavy manufacturing use, or site with underground storage tanks? If the project site is suspected of containing hazardous materials, would the project involve 50 cubic yards or more of soil disturbance?
- Soils Disturbance/Modification:** Would the project result in soil disturbance greater than 2 feet below grade in an archeological sensitive area or 8 feet in a non-archeological sensitive area?

Slope/Geological Hazards: If located on slopes of 20% or greater, in a landslide or liquefaction zone, does the project involve excavation of 50 cubic yards of soil or more, new construction, or square footage expansion greater than 1,000 sq. ft. outside of the existing building footprint?

Hydrology/Water Quality: Would the project cause flooding impacts, violate water quality standards, result in on- or off-site erosion impacts, or otherwise substantially degrade water quality?

Biology: Would the project have the potential to impact sensitive species, rare plants or designated critical habitat? Is the project consistent with the applicable tree protection ordinance?

Visual: Is the project located within or adjacent to a designated scenic roadway, or would the project have the potential to impact scenic resources that are visible from public locations?

Transportation: Would project construction or operation have the potential to adversely affect existing traffic patterns, transit operations, pedestrian and/or bicycle safety (hazards), or the adequacy of nearby transit, pedestrian and/or bicycle facilities?

Historical Resources: Is the project located on a site with a known or potential historical resource?

Other: _____

3. CATEGORICAL EXEMPTION DETERMINATION

Further Environmental Review Required.

Notes: _____

No Further Environmental Review Required. Project is categorically exempt under CEQA.

Timothy J. Johnston Digitally signed by Timothy J. Johnston
Date: 2019.10.24 14:14:49 -07'00'

Planner's Signature

10/24/2019

Date

Timothy Johnston, senior environmental planner

Name, Title

Project Approval Action: SFPUC public hearing

Once signed and dated, this document constitutes a categorical exemption pursuant to CEQA Guidelines and Chapter 31 of the Administrative Code.



PUBLIC PROJECT APPLICATION

The purpose of the Public Project Application is to collect all relevant information necessary for the Planning Department to appropriately conduct environmental review. Unless otherwise specified by your liaison at Environmental Planning, please submit a completed Public Project Application, along with necessary materials to CPC.EPIntake@sfgov.org.

Once a project is received, you will be contacted regarding payment and/or any additional materials necessary. When payment and/or all missing materials are received; you will receive an email with the ENV case number and contact information for the assigned planner.

Please note that this application is only for projects that do not require an entitlement decision from the San Francisco Planning Commission and/or review of a building permit by Current Planning. For projects requiring an entitlement or review by Current Planning, please complete a regular Project Application and submit according to the submittal instructions outlined in the application.

PROJECT INFORMATION

Property Information

Project Address: **398 Quint Street**

Block/Lot(s): **5227 001**

Applicant Information

Public Agency: **SFPUC**

Name: **Scott MacPherson**

Phone Number: **(415) 551-4525**

Email: **smacpherson@sfgwater.org**

REQUIRED MATERIALS

- Electronic set of plans (11x17) Please see the Department's Plan Submittal Guidelines for more information.
- Photos of proposed work areas/project site.
- Necessary background reports and supplemental applications (specified in Environmental Evaluation Screening Form)
- MTA only: Synchro data for lane reductions and traffic calming projects.

PROJECT DESCRIPTION

Please provide a narrative project description that summarizes the project and its purpose. If additional space is necessary, please attach a separate document with a complete project description.

The SFPUC is proposing a substation on the northwestern portion of its 398 Quint parcel, within an approximate 10,500 square foot triangular areas (see attached site plan). To account for future Sea Level Rise, the site elevation will be raised by approximately 3.5 feet. The substation will be bounded on the three sides with a fire-rated concrete perimeter wall, approximately 12' to 20' in height. The electrical equipment will be mounted to concrete pads founded on driven precast concrete piles. The precast concrete piles utilized both for the pile caps and perimeter wall will be 14" square and approximately 120' in length. Two large vaults (12' wide x 30' long x 11' deep and 10' wide x 48' long x 11' deep) will be excavated and installed below the Substation. Streetscape improvements, including sidewalks and landscape plantings, will be included along Davidson Avenue.

APPROVAL ACTION

In accordance with Chapter 31 of the San Francisco Administrative Code, an appeal of an exemption determination can only be filed within 30 days of the project receiving the first approval action.

Project Approval Action:	SFPUC public hearing
Will the approval action be taken at a noticed public hearing?	<input checked="" type="checkbox"/> YES* <input type="checkbox"/> NO **
* If YES is checked, please see below. **Email CPC.EPIntake@sfgov.org the date of the approval	

IF APPROVAL ACTION IS TAKEN AT A NOTICED PUBLIC HEARING, INCLUDE THE FOLLOWING CALENDAR LANGUAGE:

End of Calendar:

CEQA Appeal Rights under Chapter 31 of the San Francisco Administrative Code. If the Commission approves an action identified by an exemption or negative declaration as the Approval Action (as defined in S.F. Administrative Code Chapter 31, as amended, Board of Supervisors Ordinance Number 161-13), then the CEQA decision prepared in support of that Approval Action is thereafter subject to appeal within the time frame specified in S.F. Administrative Code Section 31.16. Typically, an appeal must be filed within 30 calendar days of the Approval Action. For information on filing an appeal under Chapter 31, contact the Clerk of the Board of Supervisors at City Hall, 1 Dr. Carlton B. Goodlett Place, Room 244, San Francisco, CA 94102, or call (415) 554-5184. If the Department's Environmental Review Officer has deemed a project to be exempt from further environmental review, an exemption determination has been prepared and can be obtained on-line at <http://sf-planning.org/index.aspx?page=3447>. Under CEQA, in a later court challenge, a litigant may be limited to raising only those issues previously raised at a hearing on the project or in written correspondence delivered to the Board of Supervisors, Planning Commission, Planning Department or other City board, commission or department at, or prior to, such hearing, or as part of the appeal hearing process on the CEQA decision. Individual calendar items: This proposed action is the Approval Action as defined by S.F. Administrative Code Chapter 31.

Individual calendar items:

This proposed action is the Approval Action as defined by S.F. Administrative Code Chapter 31.





ENVIRONMENTAL EVALUATION SCREENING FORM

This form will determine the level of environmental review required. You will be contacted by CPC.EPIntake@sfgov.org with a payment request and planner contact information.

If you are submitting an application for entitlement, please submit the Project Application with either Building Permit or Entitlement Intake Appointment.

Environmental Topic	Information	Applicable to Proposed Project?	Notes/Requirements
1a. General	Estimated construction duration (months):	N/A	<u>approximately 9 months</u>
1b. General	Does the project involve replacement or repair of a building foundation? If yes, please provide the foundation design type (e.g., mat foundation, spread footings, drilled piers, etc)	<input type="checkbox"/> Yes <input checked="" type="checkbox"/> No	<hr/>
2. Transportation	Does the project involve a child care facility or school with 30 or more students, or a location 1,500 square feet or greater?	<input type="checkbox"/> Yes <input checked="" type="checkbox"/> No	If yes, submit an Environmental Supplemental- School and Child Care Drop-Off & Pick-Up Management Plan .
3. Shadow	Would the project result in any construction over 40 feet in height?	<input type="checkbox"/> Yes <input checked="" type="checkbox"/> No	If yes, an initial review by a shadow expert, including a recommendation as to whether a shadow analysis is needed, may be required, as determined by Planning staff. (If the project already underwent Preliminary Project Assessment, refer to the shadow discussion in the PPA letter.) An additional fee for a shadow review may be required.
4. Biological Resources	Does the project include the removal or addition of trees on, over, or adjacent to the project site?	<input checked="" type="checkbox"/> Yes <input type="checkbox"/> No	If yes: Number of existing trees on, over, or adjacent to the project site: <u>2</u> Number of existing trees on, over, or adjacent to the project site that would be removed by the project: <u>2</u> Number of trees on, over, or adjacent to the project site that would be added by the project: <hr/>
5a. Historic Preservation 	Would the project involve changes to the front façade or an addition visible from the public right-of-way of a structure built 45 or more years ago or located in a historic district?	<input type="checkbox"/> Yes <input checked="" type="checkbox"/> No	If yes, submit a complete Historic Resource Determination Supplemental Application . Include all materials required in the application, including a complete record (with copies) of all building permits.
5b. Historic Preservation	Would the project involve demolition of a structure constructed 45 or more years ago, or a structure located within a historic district?	<input type="checkbox"/> Yes <input checked="" type="checkbox"/> No	If yes, a historic resource evaluation (HRE) report will be required. The scope of the HRE will be determined in consultation with CPC-HRE@sfgov.org .

 Please see the [Property Information Map](#) or speak with Planning Information Center (PIC) staff to determine if this applies.

Environmental Topic	Information	Applicable to Proposed Project?	Notes/Requirements
6. Archeology 	Would the project result in soil disturbance/modification greater than two (2) feet below grade in an archeologically sensitive area or eight (8) feet below grade in a non-archeologically sensitive area?	<input checked="" type="checkbox"/> Yes <input type="checkbox"/> No	If Yes, provide depth of excavation/disturbance below grade (in feet*): <i>*Note this includes foundation work</i>
7. Geology and Soils 	Is the project located within a Landslide Hazard Zone, Liquefaction Zone or on a lot with an average slope of 20% or greater? ----- Area of excavation/disturbance (in square feet): Amount of excavation (in cubic yards): 2,325	<input type="checkbox"/> Yes <input checked="" type="checkbox"/> No	A geotechnical report prepared by a qualified professional must be submitted if one of the following thresholds apply to the project: <ul style="list-style-type: none"> ● The project involves: <ul style="list-style-type: none"> ○ excavation of 50 or more cubic yards of soil, or ○ building expansion greater than 1,000 square feet outside of the existing building footprint. ● The project involves a lot split located on a slope equal to or greater than 20 percent. <i>A geotechnical report may also be required for other circumstances as determined by Environmental Planning staff.</i>
8. Air Quality 	Would the project add new sensitive receptors (specifically, schools, day care facilities, hospitals, residential dwellings, and senior-care facilities) within an Air Pollutant Exposure Zone?	<input type="checkbox"/> Yes <input checked="" type="checkbox"/> No	If yes, the property owner must submit copy of initial filed application with department of public health. More information is found here .
9a. Hazardous Materials	Would the project involve work on a site with an existing or former gas station, parking lot, auto repair, dry cleaners, or heavy manufacturing use, or a site with underground storage tanks?	<input checked="" type="checkbox"/> Yes <input type="checkbox"/> No	If yes, submit a Phase I Environmental Site Assessment prepared by a qualified consultant.
9b. Hazardous Materials 	Is the project site located within the Maher area and would it involve ground disturbance of at least 50 cubic yards or a change of use from an industrial use to a residential or institutional use?	<input checked="" type="checkbox"/> Yes <input type="checkbox"/> No	If yes, submit a copy of the Maher Application Form to the Department of Public Health. Also submit a receipt of Maher enrollment with the Project Application. For more information about the Maher program and enrollment, refer to the Department of Public Health's Environmental Health Division . <i>Maher enrollment may also be required for other circumstances as determined by Environmental Planning staff.</i>

 Please see the [Property Information Map](#) or speak with Planning Information Center (PIC) staff to determine if this applies.



October 8, 2019

Mr. Timothy Johnston, MP, Environmental Planner
 Environmental Planning Division
 San Francisco Planning Department
 1650 Mission Street, Fourth Floor
 San Francisco, CA 94103

RE: 398 Quint Substation Project
 CEQA Exemption Request
 Case No. 2019-013330ENV
 ("CUH87002: Bay Corridor Transmission
 Distribution (BCTD) in eTime)

Dear Timothy:

The San Francisco Public Utilities Commission (SFPUC) requests review of the proposed Bay Corridor Transmission and Distribution Project (project) under the California Environmental Quality Act (CEQA). The purposes of this letter are to: 1) Provide the Environmental Planning (EP) Division with a detailed description of the project, and 2) Request EP review and concurrence that the proposed project is categorically exempt under CEQA State Guidelines Section 15303, (Class 3 New Construction or Conversion of Small Structures). Class 3 consists of construction and location of limited numbers of new, small facilities or structures, including "water main, sewage, electrical, gas and other utility extensions".

The following description provides relevant background information regarding the purpose and need for the project and presents an analysis of potential environmental effects that demonstrates that the project would not result in adverse environmental effects, and provides support for our recommendation that the activities are categorically exempt under CEQA.

The project would be conducted in compliance with applicable federal, State and local regulations, and under contractual provisions prohibiting work in violation of applicable regulations and plans. Contractors would comply with all applicable SFPUC Standard Construction Measures, issued July 1, 2015, which are on file at EP.

OUR MISSION: To provide our customers with high-quality, efficient and reliable water, power and sewer services in a manner that values environmental and community interests and sustains the resources entrusted to our care.

- London N. Breed**
Mayor
- Ann Moller Caen**
President
- Francesca Vietor**
Vice President
- Anson Moran**
Commissioner
- Sophie Maxwell**
Commissioner
- Tim Paulson**
Commissioner
- Harlan L. Kelly, Jr.**
General Manager



Background

The SFPUC is San Francisco's municipal power utility. The SFPUC also provides electric services to select local residential and business communities. The SFPUC owns and operates the Hetch Hetchy Power System (HHPS), the main source of SFPUC's power. The HHPS network supplies clean energy to most of San Francisco's municipal facilities, services and customers, which includes San Francisco International Airport; San Francisco General Hospital; MUNI; Police; Fire; retail tenants, residences and businesses in the San Francisco Shipyard; Treasure Island and more. The HHPS is composed of three hydroelectric powerhouses with a combined total hydroelectric output of nearly 400 megawatts (MW). The SFPUC also generates over 10 MW of clean, renewable energy from 19 solar arrays and 2 biogas cogeneration facilities.

To reduce costs and SFPUC's reliance on Pacific Gas and Electric Company (PG&E) for delivery of distribution-level electricity to customers, the SFPUC must increase investment in local distribution assets.

Project Description

The project would be located at the 398 Quint Street parcel, which is bisected by existing railroad tracks. The substation would be constructed on the northwestern portion of the property within an approximate 10,500 square foot triangular area bordered on the north by Davidson Avenue and to the southeast by the existing railroad tracks (see attached site plan). Project components include incoming underground high voltage (HV) power conductors, outgoing underground medium voltage (MV) power conductors, electrical power protection equipment, power transformers, HV and MV switchgear, control systems, MV distribution equipment, and associated equipment required for power system operation.

The SFPUC Substation would receive power at 230 Kilovolts (kV) from Pacific Gas and Electric Company (PG&E) Potrero Substation (Potrero) via a transmission line consisting of three, insulated single-conductor copper cables routed through underground duct banks. The substation would include two 62.5 megavolt-ampere (MVA) transformers, to convert incoming power at 230kV to power at 12.47kV for distribution to customers. Gas Insulated Switchgear (GIS) would serve as the protection for and the electrical disconnect between the incoming HV 230kV transmission line and the HV transformer. 12.47 kV metal-

clad switchgear would be installed to facilitate the power supply to planned customers in the north utilizing insulated copper cables routed through underground duct banks.

The substation would be bounded on the three sides with a fire-rated concrete or metal perimeter wall, approximately 12 to 20 feet in height. The perimeter wall would be supported by driven precast concrete piles. The electrical equipment would be mounted to concrete pads founded on impact-driven precast concrete piles. The precast concrete piles utilized both for the pile caps and perimeter wall would be 14 inches square and approximately 120 feet in length. Two large vaults (12-foot wide x 30-foot long x 11-foot deep and 10-foot wide x 48-foot long x 11-foot deep) would be excavated and installed below the Substation to facilitate cable routing into and out of the electrical equipment. To account for future Sea Level Rise, the site elevation would be raised by approximately 3.5 feet. The deepest excavation is anticipated to be approximately 15 feet for the 11-ft deep vault, measured from the finished grade (12.5 feet below the existing grade). Aggregate base would be placed around the electrical equipment to ensure proper drainage of the site. Streetscape improvements, including sidewalks and landscape plantings, would be included along Davidson Avenue. Two street trees would be removed. Additional site improvements such as initial clearing and grubbing of existing conditions, site lighting, fencing, security cameras, grading, and drainage would be included. Most of the construction would be restricted to the 398 Quint Street Site, except a connection to underground power lines under Davidson Avenue, adjacent to the project site.

The substation is expected to be completed in approximately nine months, with work beginning in 2020.

The project would include pre-construction borings to characterize soil conditions, and geoarcheological testing.

Approximately 2,325 cubic yards and 3,750 cubic yards of material would be excavated and imported, respectively. Based on a 16-cubic yard capacity dump truck, approximately 760 one-way truck trips would be required to import and export material as necessary, or approximately four per day.

Access and Staging

Access would be through Davidson Avenue. Construction equipment and materials would be staged within the site or within the areas of public right-of-way including the sidewalk, parking lane, and roadways near the site.

Project Equipment

The proposed project would require the following pieces of equipment:

- Crane
- Pile Driver
- Concrete Trucks
- Water Truck
- Excavator
- Backhoe/Front End Loader
- Air Compressor
- Diesel Generator
- Flatbed Truck
- Dump Truck
- Compactor
- Work Crew Passenger Vehicles

The work crew would vary between approximately 10 and 13 members per day. Approximately ten passenger vehicles would be used to transport work crew members to and from the project site each day.

Setting

The project is located in the Bayview Hunters Point neighborhood. The project is located within PDR and Industrial uses, including the Southeast Treatment Plant across Evans Ave. to the south. A wastewater pump station (Bruce Flynn Pump Station) is located on the same parcel as the project.

Schedule

Construction would take approximately nine months. This work could be discontinuous and is estimated to occur between January 2020 and December 2022. Construction would typically occur weekdays between 7 a.m. and 5 p.m. but could also extend to 8 p.m. depending on construction restrictions. While not expected, weekend work could also be required.

ENVIRONMENTAL INFORMATION

Aesthetics

The project location is currently enclosed by an approximately ten-foot-high corrugated steel fence. The neighborhood is industrial, and nearby buildings are either utility oriented or warehouses. The project includes a 12 to 20-foot high wall on three sides, of which bushings on the top of the transformers would extend above the wall by an estimated three to five feet. Two trees would be removed on Davidson Street. While the visual character of the site would be modified, the project would be visually similar to other industrial and utility uses in the area (such as the Bruce Flynn Pump Station, on the same parcel). Therefore, adverse effects to aesthetics would not be expected.

Air Quality

The proposed project construction equipment and vehicles would comply with the City's Clean Construction Ordinance (CCO). As the project is in an Air Pollutant Exposure Zone (APEZ), equipment would be required to have Tier 2 or higher engines **and** the most effective Verified Diesel Emission Control strategy (VDECS) available for the engine type (Tier 4 engines automatically meet this requirement) as certified by the California Air Resources Board. This project would use Tier 4 equipment as required in the contract specifications.

The SFPUC has estimated the criteria air pollutants generated during project construction based on the maximum number of pieces of equipment that might be operating at one time, a summary of which is shown in Tables 1 and 2 (See Attachment, "Memorandum Bay Corridor Transmission and Distribution Project Air Quality Analysis and Results" for full results).

Cumulative Emissions

An analysis was conducted to determine if other Hetch Hetchy Power System projects in the vicinity would result in significant cumulative effects. This work consists of Contract DB-128R2 (installation of electrical lines in Mission Bay) and DB-129 (installation of electrical lines in south Mission Bay and northern Bayview and ground improvements adjacent to and Islais Creek conduit crossing). While the DB-128R2 contract is scheduled to be completed before construction of the proposed project, we have included emissions estimates for

2020 as a conservative assumption. These contracts specify Tier 4 equipment must be used. The analysis is summarized in Tables 3 and 4, below.

Table 1: Project Emissions 2020

Pollutant	Project emissions (lbs/day)	May 2011 BAAQMD Thresholds (lbs/day)
PM ₁₀	0.03	54
PM _{2.5}	0.03	82
NO _x	1.84	54
ROG	0.29	54

Project emissions derived from the *Memorandum Bay Corridor Transmission and Distribution Project Air Quality Analysis and Results*, attached, Table 7. Average Daily Emissions are calculated based on approximately 154 workdays in 2020

Table 2: Project Emissions 2021

Pollutant	Project emissions (lbs/day)	May 2011 BAAQMD Thresholds (lbs/day)
PM ₁₀	0.04	54
PM _{2.5}	0.04	82
NO _x	4.51	54
ROG	0.35	54

Project emissions derived from the *Memorandum Bay Corridor Transmission and Distribution Project Air Quality Analysis and Results*, attached, Table 8. Average Daily Emissions are calculated based on approximately 42 workdays in 2021.

Table 3: Cumulative Project Emissions 2020

Pollutant	Project emissions (lbs/day)	May 2011 BAAQMD Thresholds (lbs/day)
PM ₁₀	0.13	54
PM _{2.5}	0.13	82
NO _x	22.54	54
ROG	1.18	54

Project emissions derived from the *Memorandum Bay Corridor Transmission and Distribution Project Air Quality Analysis and Results*, attached, Table 9. Average Daily Emissions are calculated based on approximately 154 workdays in 2020.

Table 4: Cumulative Project Emissions 2021

Pollutant	Project emissions (lbs/day)	May 2011 BAAQMD Thresholds (lbs/day)
PM ₁₀	0.10	54
PM _{2.5}	0.10	82
NO _x	15.08	54
ROG	0.90	54

Project emissions derived from the *Memorandum Bay Corridor Transmission and Distribution Project Air Quality Analysis and Results*, attached, Table 10. Average Daily Emissions are calculated based on approximately 42 workdays in 2021.

Per SFPUC Standard Construction Measure Number 2, the proposed project construction equipment and vehicles would comply with the City's Clean Construction Ordinance and Construction Dust Control Ordinance. To meet air quality thresholds, the project would (as necessary) implement air quality controls to be tailored to the project, such as restricting the number of crews operating at the same time, Verified Diesel Emissions Control Strategies (VDECS) such as diesel particulate filters, customized construction schedules and procedures, and low emissions fuel.

Given the project would comply with construction dust and criteria emissions standards, adverse effects on air quality would not be expected.

Biological Resources

The project is located on an urban, paved parcel and the only biological resources that would be affected are two street trees, which would be removed. In accordance with SFPUC Standard Construction Measure Number 7, trees to be removed would be surveyed for nesting birds between February 15 and August 31 to ensure active migratory bird nests (containing eggs or chicks), if present, are not destroyed. The project would comply with the Urban Forestry Ordinance (Article 16 of the San Francisco Public Works Code). Therefore, adverse effects to biological resources would not be expected.

Cultural Resources

Far Western's draft (2019) prehistoric sensitivity model maps the project site as not sensitive for near surface or buried prehistoric resources. Sensitivity for submerged resources is ranked as moderate, since the project site was

inundated by the rising bay between 8,000 and 6,000 years ago, at which time the bay region is believed to have been only very sparsely settled. However, the project site is in the same age-of-submergence band in which two isolate prehistoric lithic flakes were encountered at the SEP. On this basis, there is the potential for the presence of very deeply buried early Holocene sites to be affected by pile construction at the project site. Some geotechnical cores in the vicinity also encountered a deeply buried thick layer of plants, which may be suggestive of a buried terrestrial surface.

Historic mapping suggests that although there was a 19th century tannery operation on a wharf or elevated berm along Evans Street adjacent to the project block, the project block itself was within the Islais Creek Estuary and was not filled until approximately 1915. One geotechnical core in Evans Ave encountered a thick wood layer that likely represents the wooden boardwalk on which the tanneries operated. It is unlikely that this boardwalk extends into the project area. Tannery waste (bone, hair, possibly industrial or residential debris) could be present in the upper layers of the Young Bay sediments that underlie the project site. Project excavations would only marginally penetrate the overlying recent fill and are unlikely to expose this material, but it could be encountered by pile drilling. While its information potential is likely limited, sampling for characterization would be appropriate. Post fill development of the project site appears to have been confined to use as a lumber yard. This included a waste burning facility (Sanborn 1950: 808); resultant material may be present in the fill on the project site. This material is unlikely to have significant information potential, as it would be expected to consist primarily of wood ash and other material routinely associated with modern lumber operations.

The potential of the project to adversely affect archeological resources may be avoided by implementation of SFPUC Standard Archeological Measure I (Discovery during Construction, and SFPUC Standard Archeological Measure III (Archeological Testing), which would consist of geoarchaeological testing prior to construction.

The project therefore would not result in adverse effects to archeological and historic resources.

Hazardous Materials

BEM staff reviewed the State Water Resources Control Board (SWRQB) GeoTracker and Department of Toxic Substances Control (DTSC) Envirostor databases. The closest site is a closed LUST cleanup location at Circosta Iron & Metal at 1801 Evans Avenue. During construction, the project would follow the requirements of the Maher Ordinance (Article 22A of the San Francisco Health Code). Therefore, adverse effects related to hazardous materials are not expected to occur.

Noise

Operational Noise

Each transformer (only one of which would be used at a time) could generate up to 81 dBA at six feet. The nearest sensitive receptor is a residential complex located at 3900 Third Street, approximately 1,100 feet away. At that distance, noise would be approximately 36 dBA¹, which is far below ambient nighttime noise levels in the area². This is a very conservative calculation, as the actual noise would be expected to be significantly lower due to intervening structures and the project wall.

Construction Noise

During construction, the project would follow the requirements of the San Francisco noise ordinance (Article 29 of the San Francisco Police Code).

Therefore, adverse effects related to noise are not expected to occur.

Transportation

Construction would require the temporary closure of the south lane of Davidson Avenue, and the temporary occupancy of on-street parking spaces. Construction staging and delivery vehicles may temporarily impede traffic flow on Davidson Avenue and surrounding streets. If necessary, through traffic may be temporarily detoured around the construction site to avoid conflicts with

¹ Calculated by using the inverse square law.

² The Biosolids Digester Facilities Project Final EIR measured ambient nighttime noise levels (Leq) between 55 and 64 dBA. *Biosolids Digester Facilities Project Final EIR*, page 4.7-10 (Case No. 2015-000644ENV).

construction equipment. During the construction period, temporary and intermittent traffic and transit delays may result from truck movements to and from the construction site. In general, parking lane, travel lane, and sidewalk closures are subject to review and approval by the City's Transportation Advisory Staff Committee (TASC) which consists of representatives from City departments including the SFMTA, Public Works, Fire, Police, Public Health, the Port, and the Taxi Commission. The TASC review and approval process takes into consideration other construction projects in the vicinity (such as other SFPUC utility projects); pedestrian, transit and traffic operations; and specific land uses. If detours are necessary, street signs and flaggers would clearly identify the detours around the construction site. Open trenches would be covered with steel plates at the intersections and along transit routes outside of construction hours.

Traffic generated by construction vehicles for the proposed project would be approximately 25 truck trips per day, or three truck trips per hour.

Growth Inducement

While the proposed project would transmit power, it would not generate power. Power would be generated from the existing Hetch Hetchy Power System (HHPS), which would be transmitted to the project through the PG&E Potrero Substation. If this project is not implemented, PG&E would continue to distribute power through its own system, and the amount of power generated by the existing HHPS would not change. As PG&E is required to distribute power to customers within its service area, new customers (whose projects would require separate CEQA review) would continue to be served with or without the proposed project.

As the project would not foster economic or population growth, result in the construction of additional housing, or remove obstacles to population growth, adverse effects related to growth inducement would not be anticipated.

CEQA Compliance/Recommendation

The SFPUC recommends that EP determine the proposed 398 Quint Street Substation Project is exempt under CEQA Guidelines 15303, (Class 3 New Construction or Conversion of Small Structures).

Mr. Timothy Johnston, MP, Environmental Planner
Environmental Planning Division, San Francisco Planning Department
398 Quint Street Substation Project Exemption Request
October 8, 2019
Page 11

Should you have questions regarding the proposed Project, Environmental Project Manager Scott MacPherson can be reached at (415) 551-4525.

Sincerely,

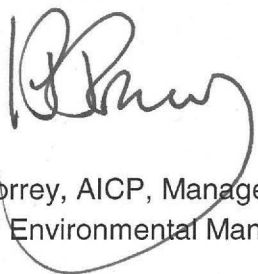
A handwritten signature in black ink, appearing to read 'Irina P. Torrey', written over a circular stamp or seal.

Irina P. Torrey, AICP, Manager
Bureau of Environmental Management

Attachments:

Site plan
Bay Corridor Transmission and Distribution Project Alignment Emissions

cc: Scott MacPherson, Environmental Project Manager, SFPUC Bureau of
Environmental Management
David Myerson, Project Manager, SFPUC

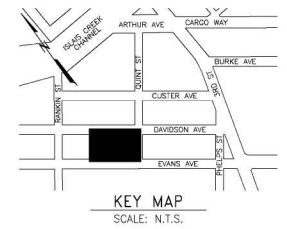
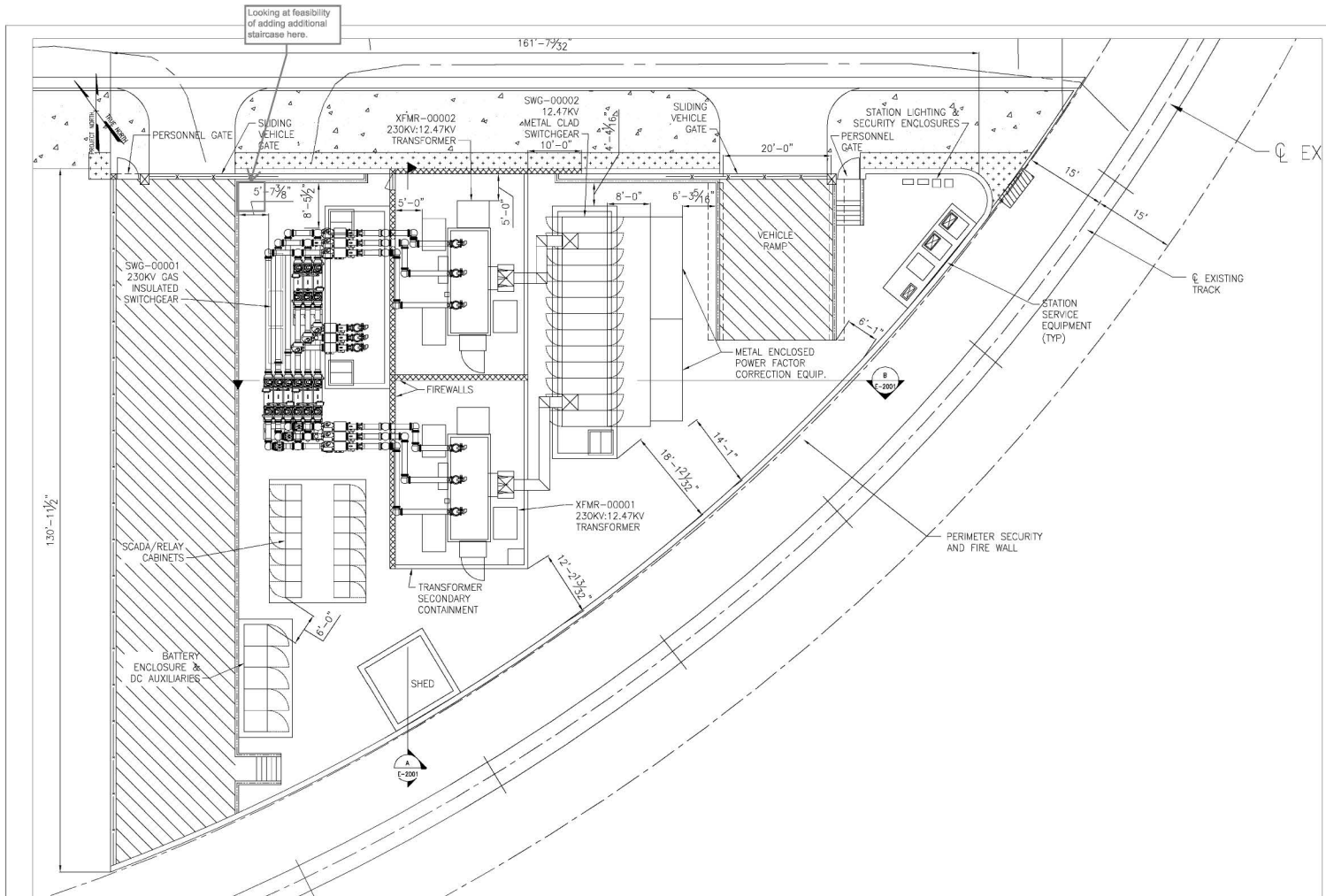

LOCATION MAP
SCALE: 1" = 10'

35% SUBMITTAL

NOT FOR CONSTRUCTION
CONTRACT NO. DB-130

CITY AND COUNTY OF SAN FRANCISCO
PUBLIC UTILITIES COMMISSION
INFRASTRUCTURE DIVISION
ENGINEERING MANAGEMENT BUREAU
BAY CORRIDOR TRANSMISSION AND DISTRIBUTION
PHASE 3 (2019)

GENERAL ARRANGEMENT

AECOM
300 California Street, Suite 800
San Francisco, CA 94104
Tel: 415-798-8100
Fax: 415-798-8000



PROJECT ENGINEER D. GONNARD	DRAWN A. NEWBERG	CHECKED / APPROVED	DATE
PROJECT MANAGER D. PYTE	DESIGNED R. AULT	SCALE	AS SHOWN
APPROVED M. ADAMS	CHECKED	APPROVED	08/09/2019
REVISIONS		MANAGER ENGINEERING MANAGEMENT BUREAU	MANAGER POWER DISTRIBUTION
NO.	DATE	DESCRIPTION	BY

PLAN NO.	DATE / FILE NO.	REVISION NO.
E-1001	E-	0



FOR THE SOLE USE OF THE DOCUMENT RECIPIENT - DO NOT CITE, COPY, OR CIRCULATE WITHOUT THE EXPRESSED PERMISSION OF THE SFPUC.

Project name:
Bay Corridor Transmission and
Distribution Project

To:
Scott MacPherson
San Francisco Public Utilities Commission

From:
Paola Peña
Amir Fanai
David Fyfe
AECOM

Cc:
Jack Lin
David Myerson
San Francisco Public Utilities Commission

Date:
October 2, 2019

Memorandum – DRAFT –

Subject: Bay Corridor Transmission and Distribution Project Air Quality Analysis and Results

AECOM has prepared this air quality technical memorandum (memo) for the remaining work that is to be constructed under the Bay Corridor Transmission and Distribution (BCTD) Phase 1 and Phase 2 Projects (project). The purpose of this memo is to demonstrate that the project would not result in adverse environmental effects to air quality and provide support that the activities are categorically exempt under the California Environmental Quality Act (CEQA). The remaining contracts include BCTD DB128R2, DB129.1 DB129.2, and DB130. The following sections present the methodology and results for the different contracts in comparison to Bay Area Air Quality Management District (BAAQMD) thresholds.

Project Description

The SFPUC is proposing underground electrical power improvements required to deliver power to customers along the eastern San Francisco waterfront. The project is located in the Mission Bay and Bayview Hunters Point neighborhoods, from Mission Rock Street to the north, to Evans Avenue to the south. The project alignment runs along or near the eastern waterfront of the City, through a mix of industrial, residential, and commercial uses.

Air Quality Background

The project is located within the City and County of San Francisco, under the jurisdiction of the BAAQMD. The BAAQMD monitors air quality within Alameda, Contra Costa, Marin, San Francisco, San Mateo, Santa Clara, and Napa Counties and portions of Solano and Sonoma Counties in the San Francisco Bay Area Air Basin (SFBAAB). Local climatological effects, including wind speed and direction, temperature, inversion layers, and precipitation and fog, can exacerbate air quality problems in the SFBAAB. The climate of the SFBAAB is characterized by warm, dry summers and mild winters.

Individual air pollutants at certain concentrations may adversely affect human or animal health, reduce visibility, damage property, and reduce the productivity or vigor of crops and natural vegetation. Six air pollutants have been identified by the United States Environmental Protection Agency (EPA) and the California Air Resources Board (ARB) as being of concern both on a nationwide and statewide level: ozone; carbon monoxide (CO); nitrogen dioxide (NO₂); sulfur dioxide (SO₂); lead; and particulate matter (PM), which is subdivided into two classes based on particle size: PM equal to or less than 10 micrometers in diameter (PM₁₀) and PM equal to or less than 2.5 micrometers in diameter (PM_{2.5}). Because the air quality standards for these air pollutants are regulated using human and environment health-based criteria, they are commonly referred to as “criteria air pollutants.”

Thresholds and Methodology

To provide guidance for the analysis, the BAAQMD CEQA Air Quality Guidelines were consulted and used to inform environmental review. The BAAQMD CEQA Air Quality Guidelines are for informational purposes and should be followed by local governments at their own discretion (BAAQMD 2017). The CEQA Air Quality Guidelines may inform environmental review for development projects in the Bay Area, but do not commit local governments or the BAAQMD to any specific course of regulatory action. The BAAQMD Air Quality CEQA Thresholds of Significance are presented in Table 1.

Criteria air pollutants emissions were estimated for construction of the project using the methodology and assumptions discussed below. Because ozone is not directly emitted, but instead formed through the photochemical processes involving precursor chemicals [i.e. nitrogen oxides (NO_x) and reactive organic gases (ROG)] in the presence of sunlight, the precursor pollutants are those that are analyzed. Construction of the project would result in the temporary generation of ROG, NO_x, PM₁₀, and PM_{2.5} emissions associated primarily from off-road construction equipment, on-road motor vehicles, soil excavation and material transport. ROG and NO_x emissions are primarily associated with mobile equipment exhaust. Fugitive dust emissions are primarily associated with site preparation and vary as a function of such parameters as soil silt content, soil moisture, wind speed, acreage of disturbance area, and miles traveled by construction vehicles on- and off-site.

Table 1. BAAQMD Construction-Related Thresholds of Significance

Emissions Sources	ROG	NO _x	PM ₁₀ Exhaust	PM _{2.5} Exhaust	PM ₁₀ /PM _{2.5} Fugitive Dust
Thresholds of Significance (lbs/day) ^(a)	54	54	82	54	BMPs
Notes: (a) Thresholds of significance are in average daily emissions. ROG = reactive organic gases; NOX = oxides of nitrogen; PM10 = particulate matter with aerodynamic diameter less than 10 microns; PM2.5 = particulate matter with aerodynamic diameter less than 2.5 microns; lbs/day = pounds per day; BMPs = Best Management Practices Source: Thresholds from Table 2-1 of the BAAQMD CEQA Air Quality Guidelines (BAAQMD 2017)					

Construction

Construction-related emissions associated with typical construction activities were modeled using the California Emissions Estimator Model (CalEEMod), Version 2016.3.2. CalEEMod allows the user to enter project-specific construction information, such as construction schedule, types, number, and horsepower of construction equipment, and number and length of off-site motor vehicle trips. Total annual construction emissions were calculated and converted from tons to average pounds per day (lbs/day), using the estimated construction durations. Construction emissions were analyzed for each of the contracts as detailed in the following sections.

In addition, as detailed in the CEQA Exemption Request for the BCTD Project, the alignment consists of both areas outside and within an Air Pollution Exposure Zone (APEZ). The City’s Clean Construction Ordinance (CCO) requires construction in an APEZ to (1) use Tier 2 or higher engines and the most effective Verified Diesel Emission Control Strategies (VDECS) available for the engine type (Tier 4 engines automatically meet this requirement); (2) prepare a Construction Emissions Minimization Plan; and (3) monitor and document compliance. In the rest of the project alignment, the COO requires off-road equipment use biodiesel fuel grade B20 and utilize off-road equipment that either: (1) meets or exceeds Tier 2 standards for off-road engines; or (2) operates with the most effective VDECS. As this project could be constructed in segments potentially months apart, and the alignment consists of both areas outside and within an APEZ, emissions have been estimated assuming three scenarios (Tier 2 engines with B20 fuel, Tier 2 engines and Level 3 VDECS, and Tier 4 engines) for each of the three contracts. Additional assumptions and modeling outputs are provided in Attachment A.

DB-128R2

Under this contract, project construction is anticipated to continue over the next 9 months, with construction completion anticipated in June 2020. Length of trenching under this contract is anticipated to be on the order of approximately 7,255 linear feet. This contract would require the use of an excavator, jackhammer, saw cutter, dump truck, electrical generator, skid loader, concrete trucks, asphalt truck, and compact roller. The analysis assumed the construction crew would consist of approximately 15 workers. The analysis also assumed approximately 9,711 and 7,335 cubic yards (CY) of soil would be excavated and imported, respectively, during trenching. Based on a 16-CY capacity dump truck, the analysis assumed approximate 2,133 one-way truck trips would be required to import and export material as necessary.

DB-129

Under this contract, project construction is anticipated to occur over 8 months, with construction to commence in June 2020. Length of trenching under the DB-129.1 and DB-129.2 contracts is anticipated to be on the order of approximately 7,529 linear feet. The DB-129 work would require the use of an excavator, jackhammer, saw cutter, dump truck, frontend loader/backhoe, electric generator, skid loader, concrete trucks, asphalt truck, and compact roller. The analysis assumed the construction crew would consist of approximately 15 workers. The analysis also assumed approximately 40,530 and 32,315 CY of soil would be excavated and imported, respectively, during trenching under the DB-129.1 and DB-129.2 contracts. Based on a 16-CY capacity dump truck, the analysis assumed approximate 9,106 one-way truck trips would be required to import and export material as necessary. Additionally, it was assumed approximately 2,410 CY of concrete would be required during construction.

Islais Creek Bore Ground Improvements

The Islais Creek Bore ground improvements will be constructed under the DB-129.2 contract. Project construction is anticipated to occur over 4 months, with construction to commence in 2020 and coincide with the DB-129 work. This contract would require the use of an auger drilling rig, track crane, excavator, loader/backhoe, dump truck, compactor, generator, air compressor, and water tank. The analysis assumed the construction crew would consist of approximately 9 workers.

DB-130

The BCTD Electrical Substation will be constructed under the DB-130 contract. Project construction is anticipated to occur over 9 months, with construction to commence in June 2020. This contract would require the use of a crane, excavator, loader/backhoe, dump truck, concrete truck, compactor, generator, air compressor, and water truck. The analysis assumed the construction crew would consist of approximately 10 to 13 workers. The analysis also assumed approximately 2,325 CY and 3,750 CY of material would be excavated and imported, respectively. Based on a 16-CY capacity dump truck, the analysis assumed approximately 760 one-way truck trips would be required to import and export material as necessary. Additionally, it was assumed approximately 1,455 CY of concrete would be required during construction.

Results

Tables 2 through 8 show the average daily construction emissions for the contracts for each of the scenarios, in comparison to the BAAQMD thresholds of significance.

Table 2. DB-128R2 Average Daily Construction Emissions

Scenario	ROG	NO _x	PM ₁₀ Exhaust	PM _{2.5} Exhaust
Tier 2 Engines, B20 fuel	1.38	40.23	0.99	0.99
Tier 2 engines, Level 3 VDECS	1.69	39.53	0.18	0.18
Tier 4 Engines	0.75	8.05	0.09	0.09
Thresholds of Significance (lbs/day) ¹	54	54	82	54

Notes:
¹ Average Daily Emissions are calculated based on approximately 218 workdays. See Attachment A for more details.
 ROG = reactive organic gases; NO_x = oxides of nitrogen; PM₁₀ = particulate matter with aerodynamic diameter less than 10 microns; PM_{2.5} = particulate matter with aerodynamic diameter less than 2.5 microns; lbs/day = pounds per day
 Source: Thresholds from Table 2-1 of the BAAQMD CEQA Air Quality Guidelines (BAAQMD 2017)

Table 3. DB-129.1 and DB-129.2 Average Daily Construction Emissions (2020)

Scenario	ROG	NO _x	PM ₁₀ Exhaust	PM _{2.5} Exhaust
Tier 2 Engines, B20 fuel	1.06	34.41	0.52	0.52
Tier 2 engines, Level 3 VDECS	1.21	34.10	0.13	0.13
Tier 4 Engines	0.75	20.05	0.09	0.08
Thresholds of Significance (lbs/day) ¹	54	54	82	54

Notes:
¹ Average Daily Emissions are calculated based on approximately 154 workdays. See Attachment A for more details.
 ROG = reactive organic gases; NO_x = oxides of nitrogen; PM₁₀ = particulate matter with aerodynamic diameter less than 10 microns; PM_{2.5} = particulate matter with aerodynamic diameter less than 2.5 microns; lbs/day = pounds per day
 Source: Thresholds from Table 2-1 of the BAAQMD CEQA Air Quality Guidelines (BAAQMD 2017)

Table 4. DB-129.1 and DB-129.2 Average Daily Construction Emissions (2021)

Scenario	ROG	NO _x	PM ₁₀ Exhaust	PM _{2.5} Exhaust
Tier 2 Engines, B20 fuel	1.04	33.05	0.51	0.51
Tier 2 engines, Level 3 VDECS	1.18	32.74	0.13	0.13
Tier 4 Engines	0.72	18.68	0.08	0.08
Thresholds of Significance (lbs/day) ¹	54	54	82	54

Notes:
¹ Average Daily Emissions are calculated based on approximately 22 workdays. See Attachment A for more details.
 ROG = reactive organic gases; NO_x = oxides of nitrogen; PM₁₀ = particulate matter with aerodynamic diameter less than 10 microns; PM_{2.5} = particulate matter with aerodynamic diameter less than 2.5 microns; lbs/day = pounds per day
 Source: Thresholds from Table 2-1 of the BAAQMD CEQA Air Quality Guidelines (BAAQMD 2017)

Table 5. DB-129.2 (Islais Creek Ground Improvements) Average Daily Construction Emissions (2020)

Scenario	ROG	NO _x	PM ₁₀ Exhaust	PM _{2.5} Exhaust
Tier 2 Engines, B20 fuel	0.59	20.60	0.46	0.46
Tier 2 engines, Level 3 VDECS	0.73	20.21	0.08	0.08
Tier 4 Engines	0.35	1.52	0.04	0.04
Thresholds of Significance (lbs/day) ¹	54	54	82	54

Notes:
¹ Average Daily Emissions are calculated based on approximately 66 workdays. See Attachment A for more details.
 ROG = reactive organic gases; NO_x = oxides of nitrogen; PM₁₀ = particulate matter with aerodynamic diameter less than 10 microns; PM_{2.5} = particulate matter with aerodynamic diameter less than 2.5 microns; lbs/day = pounds per day
 Source: Thresholds from Table 2-1 of the BAAQMD CEQA Air Quality Guidelines (BAAQMD 2017)

Table 6. DB-129.2 (Islais Creek Ground Improvements) Average Daily Construction Emissions (2021)

Scenario	ROG	NO _x	PM ₁₀ Exhaust	PM _{2.5} Exhaust
Tier 2 Engines, B20 fuel	0.58	20.58	0.46	0.46
Tier 2 engines, Level 3 VDECS	0.72	20.18	0.08	0.08
Tier 4 Engines	0.34	1.49	0.04	0.04
Thresholds of Significance (lbs/day) ¹	54	54	82	54

Notes:
¹ Average Daily Emissions are calculated based on approximately 22 workdays. See Attachment A for more details.
 ROG = reactive organic gases; NO_x = oxides of nitrogen; PM₁₀ = particulate matter with aerodynamic diameter less than 10 microns; PM_{2.5} = particulate matter with aerodynamic diameter less than 2.5 microns; lbs/day = pounds per day
 Source: Thresholds from Table 2-1 of the BAAQMD CEQA Air Quality Guidelines (BAAQMD 2017)

Table 7. DB-130 Average Daily Construction Emissions (2020)

Scenario	ROG	NO _x	PM ₁₀ Exhaust	PM _{2.5} Exhaust
Tier 2 Engines, B20 fuel	0.51	14.85	0.37	0.37
Tier 2 engines, Level 3 VDECS	0.61	14.58	0.07	0.07
Tier 4 Engines	0.29	1.84	0.03	0.03
Thresholds of Significance (lbs/day) ¹	54	54	82	54

Notes:
¹ Average Daily Emissions are calculated based on approximately 154 workdays. See Attachment A for more details.
 ROG = reactive organic gases; NO_x = oxides of nitrogen; PM₁₀ = particulate matter with aerodynamic diameter less than 10 microns; PM_{2.5} = particulate matter with aerodynamic diameter less than 2.5 microns; lbs/day = pounds per day
 Source: Thresholds from Table 2-1 of the BAAQMD CEQA Air Quality Guidelines (BAAQMD 2017)

Table 8. DB-130 Average Daily Construction Emissions (2021)

Scenario	ROG	NO _x	PM ₁₀ Exhaust	PM _{2.5} Exhaust
Tier 2 Engines, B20 fuel	0.57	17.77	0.39	0.39
Tier 2 engines, Level 3 VDECS	0.69	17.49	0.08	0.07
Tier 4 Engines	0.35	4.51	0.04	0.04
Thresholds of Significance (lbs/day) ¹	54	54	82	54

Notes:
¹ Average Daily Emissions are calculated based on approximately 42 workdays. See Attachment A for more details.
 ROG = reactive organic gases; NO_x = oxides of nitrogen; PM₁₀ = particulate matter with aerodynamic diameter less than 10 microns; PM_{2.5} = particulate matter with aerodynamic diameter less than 2.5 microns; lbs/day = pounds per day
 Source: Thresholds from Table 2-1 of the BAAQMD CEQA Air Quality Guidelines (BAAQMD 2017)

Table 9 and 10 below show the average daily emissions associated with the potential overlap in construction activities between the DB-129.1, DB-129.2, and DB-130 contracts.

Table 9. 2020 Average Daily Construction Emissions

Scenario	ROG	NO _x	PM ₁₀ Exhaust	PM _{2.5} Exhaust
Tier 2 Engines, B20 fuel	1.82	58.09	1.08	1.08
Tier 2 engines, Level 3 VDECS	2.13	57.34	0.23	0.23
Tier 4 Engines	1.18	22.54	0.13	0.13
Thresholds of Significance (lbs/day) ¹	54	54	82	54

Notes:
¹ Average Daily Emissions are calculated based on approximately 154 workdays in 2020. See Attachment A for more details.
 ROG = reactive organic gases; NO_x = oxides of nitrogen; PM₁₀ = particulate matter with aerodynamic diameter less than 10 microns; PM_{2.5} = particulate matter with aerodynamic diameter less than 2.5 microns; lbs/day = pounds per day
 Source: Thresholds from Table 2-1 of the BAAQMD CEQA Air Quality Guidelines (BAAQMD 2017)

Table 10. 2021 Average Daily Construction Emissions

Scenario	ROG	NO_x	PM₁₀ Exhaust	PM_{2.5} Exhaust
Tier 2 Engines, B20 fuel	1.42	45.86	0.90	0.90
Tier 2 engines, Level 3 VDECS	1.68	45.21	0.18	0.18
Tier 4 Engines	0.90	15.08	0.10	0.10
Thresholds of Significance (lbs/day) ¹	54	54	82	54

Notes:
¹ Average Daily Emissions are calculated based on approximately 42 workdays in 2021. See Attachment A for more details.
 ROG = reactive organic gases; NOX = oxides of nitrogen; PM10 = particulate matter with aerodynamic diameter less than 10 microns;
 PM2.5 = particulate matter with aerodynamic diameter less than 2.5 microns; lbs/day = pounds per day
 Source: Thresholds from Table 2-1 of the BAAQMD CEQA Air Quality Guidelines (BAAQMD 2017)

Conclusion

As shown in Tables 2 through 8, average daily emissions during construction of each of the individual contracts would not exceed the recommended BAAQMD thresholds of significance. However, as shown in Table 9, average daily emissions from the potential overlap between construction activities of the DB-129.1, DB-129.2, and DB-130 would exceed the threshold of significance for NO_x in 2020 under the scenarios with Tier 2 engines with B20 fuel and Tier 2 engines with Level 3 VDECS. As such, the specifications for the contracts will require the use of Tier 4 equipment.

Attachment A: CalEEMod Outputs

DRAFT

DB-129 CalEEMod Runs

BCTD DB129.1 and DB129.2 - San Francisco County, Annual

BCTD DB129.1 and DB129.2

San Francisco County, Annual

1.0 Project Characteristics

1.1 Land Usage

Land Uses	Size	Metric	Lot Acreage	Floor Surface Area	Population
User Defined Industrial	1.00	User Defined Unit	1.32	0.00	0

1.2 Other Project Characteristics

Urbanization	Urban	Wind Speed (m/s)	4.6	Precipitation Freq (Days)	64
Climate Zone	5			Operational Year	2021

Utility Company Pacific Gas & Electric Company

CO2 Intensity (lb/MW/hr)	641.35	CH4 Intensity (lb/MW/hr)	0.029	N2O Intensity (lb/MW/hr)	0.006
---------------------------------	--------	---------------------------------	-------	---------------------------------	-------

1.3 User Entered Comments & Non-Default Data

Project Characteristics -

Land Use - Project specific acreage based on trenching limits.

Construction Phase - Project specific construction schedule.

Off-road Equipment - Equipment entered in one phase.

Off-road Equipment - Project specific construction equipment. Asphalt truck modeled as off-highway truck.

Trips and VMT - Assumes approx. 15 workers per day. Vendor trips account for concrete trucks placing approx. 3,360 CY total, using 8-CY capacity trucks. Haul truck trips based on 16-CY capacity trucks.

Grading - Default acres graded. Approx. 40,530 CY material export and 32,315 material import.

Construction Off-road Equipment Mitigation - Assumes fugitive dust control and use of Tier 2 B20 engines. Generator assumed to be electric.

BCTD DB129.1 and DB129.2 - San Francisco County, Annual

Table Name	Column Name	Default Value	New Value
tblConstEquipMitigation	FuelType	Diesel	Bio-diesel
tblConstEquipMitigation	FuelType	Diesel	Bio-diesel
tblConstEquipMitigation	FuelType	Diesel	Electrical
tblConstEquipMitigation	FuelType	Diesel	Bio-diesel
tblConstEquipMitigation	FuelType	Diesel	Bio-diesel
tblConstEquipMitigation	FuelType	Diesel	Bio-diesel
tblConstEquipMitigation	FuelType	Diesel	Bio-diesel
tblConstEquipMitigation	FuelType	Diesel	Bio-diesel
tblConstEquipMitigation	FuelType	Diesel	Bio-diesel
tblConstEquipMitigation	NumberOfEquipmentMitigated	0.00	1.00
tblConstEquipMitigation	NumberOfEquipmentMitigated	0.00	1.00
tblConstEquipMitigation	NumberOfEquipmentMitigated	0.00	1.00
tblConstEquipMitigation	NumberOfEquipmentMitigated	0.00	1.00
tblConstEquipMitigation	NumberOfEquipmentMitigated	0.00	2.00
tblConstEquipMitigation	NumberOfEquipmentMitigated	0.00	1.00
tblConstEquipMitigation	NumberOfEquipmentMitigated	0.00	1.00
tblConstEquipMitigation	NumberOfEquipmentMitigated	0.00	1.00
tblConstEquipMitigation	Tier	No Change	Tier 2
tblConstEquipMitigation	Tier	No Change	Tier 2
tblConstEquipMitigation	Tier	No Change	Tier 2
tblConstEquipMitigation	Tier	No Change	Tier 2
tblConstEquipMitigation	Tier	No Change	Tier 2
tblConstEquipMitigation	Tier	No Change	Tier 2
tblConstructionPhase	NumDays	10.00	1.00
tblConstructionPhase	NumDays	4.00	176.00
tblGrading	AcresOfGrading	0.00	1.50

BCTD DB129.1 and DB129.2 - San Francisco County, Annual

tblGrading	MaterialExported	0.00	40,530.00
tblGrading	MaterialImported	0.00	32,315.00
tblLandUse	LotAcreage	0.00	1.32
tblOffRoadEquipment	OffRoadEquipmentUnitAmount	1.00	0.00
tblOffRoadEquipment	OffRoadEquipmentUnitAmount	1.00	0.00
tblOffRoadEquipment	OffRoadEquipmentUnitAmount	1.00	0.00
tblOffRoadEquipment	UsageHours	6.00	0.00
tblOffRoadEquipment	UsageHours	6.00	0.00
tblOffRoadEquipment	UsageHours	6.00	0.00
tblOffRoadEquipment	UsageHours	7.00	8.00
tblTripsAndVMT	HaulingTripNumber	9,359.00	9,106.00
tblTripsAndVMT	VendorTripNumber	0.00	4.00
tblTripsAndVMT	WorkerTripNumber	23.00	30.00

2.0 Emissions Summary

BCTD DB129.1 and DB129.2 - San Francisco County, Annual

2.1 Overall Construction
Unmitigated Construction

Year	tons/yr										MT/yr					
	ROG	NOx	CO	SO2	Fugitive PM10	Exhaust PM10	PM10 Total	Fugitive PM2.5	Exhaust PM2.5	PM2.5 Total	Bio- CO2	NBio- CO2	Total CO2	CH4	N2O	CO2e
2020	0.1372	2.3806	1.4365	5.2500e-003	0.1058	0.0544	0.1602	0.0273	0.0511	0.0784	0.0000	524.4976	524.4976	0.1029	0.0000	527.0706
2021	0.0179	0.3091	0.2048	7.4000e-004	0.0743	6.6700e-003	0.0810	0.0175	6.2700e-003	0.0237	0.0000	73.9217	73.9217	0.0147	0.0000	74.2898
Maximum	0.1372	2.3806	1.4365	5.2500e-003	0.1058	0.0544	0.1602	0.0273	0.0511	0.0784	0.0000	524.4976	524.4976	0.1029	0.0000	527.0706

Mitigated Construction

Year	tons/yr										MT/yr					
	ROG	NOx	CO	SO2	Fugitive PM10	Exhaust PM10	PM10 Total	Fugitive PM2.5	Exhaust PM2.5	PM2.5 Total	Bio- CO2	NBio- CO2	Total CO2	CH4	N2O	CO2e
2020	0.0818	2.6494	1.3381	5.2500e-003	0.0995	0.0400	0.1395	0.0263	0.0398	0.0661	24.1931	478.5438	502.7369	0.1017	0.0000	505.2793
2021	0.0114	0.3635	0.1920	7.4000e-004	0.0680	5.6500e-003	0.0736	0.0165	5.6200e-003	0.0222	3.4563	67.3567	70.8130	0.0146	0.0000	71.1771
Maximum	0.0818	2.6494	1.3381	5.2500e-003	0.0995	0.0400	0.1395	0.0263	0.0398	0.0661	24.1931	478.5438	502.7369	0.1017	0.0000	505.2793

ROG	NOx	CO	SO2	Fugitive PM10	Exhaust PM10	PM10 Total	Fugitive PM2.5	Exhaust PM2.5	PM2.5 Total	Bio- CO2	NBio- CO2	Total CO2	CH4	N2O	CO2e
Percent Reduction	39.98	-12.02	6.77	0.00	7.04	11.66	4.23	20.86	13.56	0.00	8.78	4.16	1.17	0.00	4.14

BCTD DB129.1 and DB129.2 - San Francisco County, Annual

Quarter	Start Date	End Date	Maximum Unmitigated ROG + NOX (tons/quarter)	Maximum Mitigated ROG + NOX (tons/quarter)
1	6-1-2020	8-31-2020	1.0591	1.1502
2	9-1-2020	11-30-2020	1.0598	1.1499
3	12-1-2020	2-28-2021	0.7038	0.7841
		Highest	1.0598	1.1502

2.2 Overall Operational
Unmitigated Operational

Category	tons/yr											MT/yr					
	ROG	NOx	CO	SO2	Fugitive PM10	Exhaust PM10	PM10 Total	Fugitive PM2.5	Exhaust PM2.5	PM2.5 Total	Bio- CO2	NBio- CO2	Total CO2	CH4	N2O	CO2e	
Area	0.0000	0.0000	1.0000e-005	0.0000	0.0000	0.0000	0.0000	0.0000	0.0000	0.0000	0.0000	2.0000e-005	2.0000e-005	0.0000	0.0000	0.0000	2.0000e-005
Energy	0.0000	0.0000	0.0000	0.0000	0.0000	0.0000	0.0000	0.0000	0.0000	0.0000	0.0000	0.0000	0.0000	0.0000	0.0000	0.0000	0.0000
Mobile	0.0000	0.0000	0.0000	0.0000	0.0000	0.0000	0.0000	0.0000	0.0000	0.0000	0.0000	0.0000	0.0000	0.0000	0.0000	0.0000	0.0000
Waste																	
Water																	
Total	0.0000	0.0000	1.0000e-005	0.0000	0.0000	0.0000	0.0000	0.0000	0.0000	0.0000	0.0000	2.0000e-005	2.0000e-005	0.0000	0.0000	0.0000	2.0000e-005

BCTD DB129.1 and DB129.2 - San Francisco County, Annual

2.2 Overall Operational

Mitigated Operational

Category	tons/yr											MT/yr					
	ROG	NOx	CO	SO2	Fugitive PM10	Exhaust PM10	PM10 Total	Fugitive PM2.5	Exhaust PM2.5	PM2.5 Total	Bio- CO2	NBio- CO2	Total CO2	CH4	N2O	CO2e	
Area	0.0000	0.0000	1.0000e-005	0.0000	0.0000	0.0000	0.0000	0.0000	0.0000	0.0000	0.0000	2.0000e-005	2.0000e-005	0.0000	0.0000	0.0000	2.0000e-005
Energy	0.0000	0.0000	0.0000	0.0000	0.0000	0.0000	0.0000	0.0000	0.0000	0.0000	0.0000	0.0000	0.0000	0.0000	0.0000	0.0000	0.0000
Mobile	0.0000	0.0000	0.0000	0.0000	0.0000	0.0000	0.0000	0.0000	0.0000	0.0000	0.0000	0.0000	0.0000	0.0000	0.0000	0.0000	0.0000
Waste																	
Water																	
Total	0.0000	0.0000	1.0000e-005	0.0000	0.0000	0.0000	0.0000	0.0000	0.0000	0.0000	0.0000	2.0000e-005	2.0000e-005	0.0000	0.0000	0.0000	2.0000e-005

Percent Reduction	tons/yr											MT/yr				
	ROG	NOx	CO	SO2	Fugitive PM10	Exhaust PM10	PM10 Total	Fugitive PM2.5	Exhaust PM2.5	PM2.5 Total	Bio- CO2	NBio- CO2	Total CO2	CH4	N2O	CO2e
0.00	0.00	0.00	0.00	0.00	0.00	0.00	0.00	0.00	0.00	0.00	0.00	0.00	0.00	0.00	0.00	0.00

3.0 Construction Detail

Construction Phase

Phase Number	Phase Name	Phase Type	Start Date	End Date	Num Days Week	Num Days	Phase Description
1	Grading	Grading	6/1/2020	2/1/2021	5	176	
2	Architectural Coating	Architectural Coating	6/5/2020	6/5/2020	5	1	

BCTD DB129.1 and DB129.2 - San Francisco County, Annual

Acres of Grading (Site Preparation Phase): 0

Acres of Grading (Grading Phase): 1.5

Acres of Paving: 0

Residential Indoor: 0; Residential Outdoor: 0; Non-Residential Indoor: 0; Non-Residential Outdoor: 0; Striped Parking Area: 0 (Architectural Coating – sqft)

OffRoad Equipment

Phase Name	Offroad Equipment Type	Amount	Usage Hours	Horse Power	Load Factor
Grading	Concrete/Industrial Saws	1	2.00	81	0.73
Grading	Excavators	1	8.00	158	0.38
Grading	Generator Sets	1	4.00	84	0.74
Grading	Graders	0	0.00	187	0.41
Grading	Off-Highway Trucks	1	2.00	402	0.38
Grading	Other Construction Equipment	2	2.00	172	0.42
Grading	Rollers	1	2.00	80	0.38
Grading	Rubber Tired Dozers	0	0.00	247	0.40
Grading	Skid Steer Loaders	1	4.00	65	0.37
Grading	Tractors/Loaders/Backhoes	1	8.00	97	0.37
Architectural Coating	Air Compressors	0	0.00	78	0.48

Trips and VMT

Phase Name	Offroad Equipment Count	Worker Trip Number	Vendor Trip Number	Hauling Trip Number	Worker Trip Length	Vendor Trip Length	Hauling Trip Length	Worker Vehicle Class	Vendor Vehicle Class	Hauling Vehicle Class
Grading	9	30.00	4.00	9,106.00	10.80	7.30	20.00	LD_Mix	HDT_Mix	HHDT
Architectural Coating	0	0.00	0.00	0.00	10.80	7.30	20.00	LD_Mix	HDT_Mix	HHDT

3.1 Mitigation Measures Construction

BCTD DB129.1 and DB129.2 - San Francisco County, Annual

Use Alternative Fuel for Construction Equipment
 Use Cleaner Engines for Construction Equipment
 Water Exposed Area

3.2 Grading - 2020

Unmitigated Construction On-Site

Category	tons/yr											MT/yr				
	ROG	NOx	CO	SO2	Fugitive PM10	Exhaust PM10	PM10 Total	Fugitive PM2.5	Exhaust PM2.5	PM2.5 Total	Bio- CO2	NBio- CO2	Total CO2	CH4	N2O	CO2e
Fugitive Dust					0.0115	0.0000	0.0115	1.7100e-003	0.0000	1.7100e-003	0.0000	0.0000	0.0000	0.0000	0.0000	0.0000
Off-Road	0.0973	0.9497	0.9628	1.6300e-003		0.0500	0.0500		0.0469	0.0469	0.0000	142.7261	142.7261	0.0377	0.0000	143.6675
Total	0.0973	0.9497	0.9628	1.6300e-003	0.0115	0.0500	0.0616	1.7100e-003	0.0469	0.0486	0.0000	142.7261	142.7261	0.0377	0.0000	143.6675

BCTD DB129.1 and DB129.2 - San Francisco County, Annual

3.2 Grading - 2020

Unmitigated Construction Off-Site

Category	tons/yr										MT/yr					
	ROG	NOx	CO	SO2	Fugitive PM10	Exhaust PM10	PM10 Total	Fugitive PM2.5	Exhaust PM2.5	PM2.5 Total	Bio- CO2	NBio- CO2	Total CO2	CH4	N2O	CO2e
Hauling	0.0318	1.3877	0.4104	3.3400e-003	0.0740	4.0800e-003	0.0781	0.0201	3.9000e-003	0.0240	0.0000	355.8977	355.8977	0.0638	0.0000	357.4914
Vendor	1.1300e-003	0.0386	0.0114	8.0000e-005	2.0100e-003	1.7000e-004	2.1800e-003	5.8000e-004	1.6000e-004	7.4000e-004	0.0000	8.5258	8.5258	1.1400e-003	0.0000	8.5542
Worker	7.0200e-003	4.6700e-003	0.0519	1.9000e-004	0.0183	1.4000e-004	0.0184	4.8600e-003	1.3000e-004	4.9900e-003	0.0000	17.3480	17.3480	3.8000e-004	0.0000	17.3575
Total	0.0399	1.4310	0.4737	3.6100e-003	0.0943	4.3900e-003	0.0987	0.0256	4.1900e-003	0.0297	0.0000	381.7714	381.7714	0.0653	0.0000	383.4030

Mitigated Construction On-Site

Category	tons/yr										MT/yr					
	ROG	NOx	CO	SO2	Fugitive PM10	Exhaust PM10	PM10 Total	Fugitive PM2.5	Exhaust PM2.5	PM2.5 Total	Bio- CO2	NBio- CO2	Total CO2	CH4	N2O	CO2e
Fugitive Dust					5.1900e-003	0.0000	5.1900e-003	7.7000e-004	0.0000	7.7000e-004	0.0000	0.0000	0.0000	0.0000	0.0000	0.0000
Off-Road	0.0418	1.2185	0.8644	1.6300e-003		0.0356	0.0356	0.0356	0.0356	0.0356	24.1931	96.7724	120.9655	0.0364	0.0000	121.8763
Total	0.0418	1.2185	0.8644	1.6300e-003	5.1900e-003	0.0356	0.0408	7.7000e-004	0.0356	0.0364	24.1931	96.7724	120.9655	0.0364	0.0000	121.8763

BCTD DB129.1 and DB129.2 - San Francisco County, Annual

3.2 Grading - 2020

Mitigated Construction Off-Site

Category	tons/yr										MT/yr					
	ROG	NOx	CO	SO2	Fugitive PM10	Exhaust PM10	PM10 Total	Fugitive PM2.5	Exhaust PM2.5	PM2.5 Total	Bio- CO2	NBio- CO2	Total CO2	CH4	N2O	CO2e
Hauling	0.0318	1.3877	0.4104	3.3400e-003	0.0740	4.0800e-003	0.0781	0.0201	3.9000e-003	0.0240	0.0000	355.8977	355.8977	0.0638	0.0000	357.4914
Vendor	1.1300e-003	0.0386	0.0114	8.0000e-005	2.0100e-003	1.7000e-004	2.1800e-003	5.8000e-004	1.6000e-004	7.4000e-004	0.0000	8.5258	8.5258	1.1400e-003	0.0000	8.5542
Worker	7.0200e-003	4.6700e-003	0.0519	1.9000e-004	0.0183	1.4000e-004	0.0184	4.8600e-003	1.3000e-004	4.9900e-003	0.0000	17.3480	17.3480	3.8000e-004	0.0000	17.3575
Total	0.0399	1.4310	0.4737	3.6100e-003	0.0943	4.3900e-003	0.0987	0.0256	4.1900e-003	0.0297	0.0000	381.7714	381.7714	0.0653	0.0000	383.4030

3.2 Grading - 2021

Unmitigated Construction On-Site

Category	tons/yr										MT/yr					
	ROG	NOx	CO	SO2	Fugitive PM10	Exhaust PM10	PM10 Total	Fugitive PM2.5	Exhaust PM2.5	PM2.5 Total	Bio- CO2	NBio- CO2	Total CO2	CH4	N2O	CO2e
Fugitive Dust					0.0115	0.0000	0.0115	1.7100e-003	0.0000	1.7100e-003	0.0000	0.0000	0.0000	0.0000	0.0000	0.0000
Off-Road	0.0125	0.1197	0.1363	2.3000e-004		6.1200e-003	6.1200e-003	5.7400e-003	5.7400e-003	5.7400e-003	0.0000	20.3901	20.3901	5.3600e-003	0.0000	20.5239
Total	0.0125	0.1197	0.1363	2.3000e-004	0.0115	6.1200e-003	0.0177	1.7100e-003	5.7400e-003	7.4500e-003	0.0000	20.3901	20.3901	5.3600e-003	0.0000	20.5239

BCTD DB129.1 and DB129.2 - San Francisco County, Annual

3.2 Grading - 2021

Unmitigated Construction Off-Site

Category	tons/yr										MT/yr						
	ROG	NOx	CO	SO2	Fugitive PM10	Exhaust PM10	PM10 Total	Fugitive PM2.5	Exhaust PM2.5	PM2.5 Total	Bio- CO2	NBio- CO2	Total CO2	CH4	N2O	CO2e	
Hauling	4.3100e-003	0.1838	0.0601	4.7000e-004	0.0599	5.3000e-004	0.0604	0.0150	5.0000e-004	0.0155	0.0000	49.9394	49.9394	9.1600e-003	0.0000	0.0000	50.1684
Vendor	1.3000e-004	5.0400e-003	1.5400e-003	1.0000e-005	2.9000e-004	1.0000e-005	3.0000e-004	8.0000e-005	1.0000e-005	9.0000e-005	0.0000	1.2025	1.2025	1.6000e-004	0.0000	0.0000	1.2065
Worker	9.4000e-004	6.0000e-004	6.8800e-003	3.0000e-005	2.6100e-003	2.0000e-005	2.6300e-003	6.9000e-004	2.0000e-005	7.1000e-004	0.0000	2.3898	2.3898	5.0000e-005	0.0000	0.0000	2.3910
Total	5.3800e-003	0.1894	0.0685	5.1000e-004	0.0628	5.6000e-004	0.0634	0.0158	5.3000e-004	0.0163	0.0000	53.5316	53.5316	9.3700e-003	0.0000	0.0000	53.7658

Mitigated Construction On-Site

Category	tons/yr										MT/yr						
	ROG	NOx	CO	SO2	Fugitive PM10	Exhaust PM10	PM10 Total	Fugitive PM2.5	Exhaust PM2.5	PM2.5 Total	Bio- CO2	NBio- CO2	Total CO2	CH4	N2O	CO2e	
Fugitive Dust					5.1900e-003	0.0000	5.1900e-003	7.7000e-004	0.0000	7.7000e-004	0.0000	0.0000	0.0000	0.0000	0.0000	0.0000	0.0000
Off-Road	5.9700e-003	0.1741	0.1235	2.3000e-004	5.0900e-003	5.0900e-003	5.0900e-003	5.0900e-003	5.0900e-003	5.0900e-003	3.4563	13.8251	17.2814	5.2000e-003	0.0000	0.0000	17.4113
Total	5.9700e-003	0.1741	0.1235	2.3000e-004	5.1900e-003	5.0900e-003	0.0103	7.7000e-004	5.0900e-003	5.8600e-003	3.4563	13.8251	17.2814	5.2000e-003	0.0000	0.0000	17.4113

BCTD DB129.1 and DB129.2 - San Francisco County, Annual

3.3 Architectural Coating - 2020

Mitigated Construction Off-Site

Category	tons/yr										MT/yr						
	ROG	NOx	CO	SO2	Fugitive PM10	Exhaust PM10	PM10 Total	Fugitive PM2.5	Exhaust PM2.5	PM2.5 Total	Bio- CO2	NBio- CO2	Total CO2	CH4	N2O	CO2e	
Hauling	0.0000	0.0000	0.0000	0.0000	0.0000	0.0000	0.0000	0.0000	0.0000	0.0000	0.0000	0.0000	0.0000	0.0000	0.0000	0.0000	0.0000
Vendor	0.0000	0.0000	0.0000	0.0000	0.0000	0.0000	0.0000	0.0000	0.0000	0.0000	0.0000	0.0000	0.0000	0.0000	0.0000	0.0000	0.0000
Worker	0.0000	0.0000	0.0000	0.0000	0.0000	0.0000	0.0000	0.0000	0.0000	0.0000	0.0000	0.0000	0.0000	0.0000	0.0000	0.0000	0.0000
Total	0.0000	0.0000	0.0000	0.0000	0.0000	0.0000	0.0000	0.0000	0.0000	0.0000	0.0000	0.0000	0.0000	0.0000	0.0000	0.0000	0.0000

4.0 Operational Detail - Mobile

4.1 Mitigation Measures Mobile

BCTD DB129.1 and DB129.2 - San Francisco County, Annual

Category	tons/yr													MT/yr			
	ROG	NOx	CO	SO2	Fugitive PM10	Exhaust PM10	PM10 Total	Fugitive PM2.5	Exhaust PM2.5	PM2.5 Total	Bio- CO2	NBio- CO2	Total CO2	CH4	N2O	CO2e	
Mitigated	0.0000	0.0000	0.0000	0.0000	0.0000	0.0000	0.0000	0.0000	0.0000	0.0000	0.0000	0.0000	0.0000	0.0000	0.0000	0.0000	
Unmitigated	0.0000	0.0000	0.0000	0.0000	0.0000	0.0000	0.0000	0.0000	0.0000	0.0000	0.0000	0.0000	0.0000	0.0000	0.0000	0.0000	

4.2 Trip Summary Information

Land Use	Average Daily Trip Rate			Unmitigated Annual VMT	Mitigated Annual VMT
	Weekday	Saturday	Sunday		
User Defined Industrial	0.00	0.00	0.00		
Total	0.00	0.00	0.00		

4.3 Trip Type Information

Land Use	Miles						Trip %			Trip Purpose %		
	H-W or C-C	H-S or C-C	H-O or C-NW	H-W or C-W	H-S or C-C	H-O or C-NW	Primary	Diverted	Pass-by	Primary	Diverted	Pass-by
User Defined Industrial	9.50	7.30	7.30	0.00	0.00	0.00	0	0	0	0	0	0

4.4 Fleet Mix

Land Use	LDA	LDT1	LDT2	MDV	LHD1	LHD2	MHD	HHD	OBUS	UBUS	MCY	SBUS	MH
User Defined Industrial	0.606408	0.040118	0.191445	0.088323	0.014900	0.004926	0.028280	0.008891	0.004289	0.004272	0.006741	0.000931	0.000477

5.0 Energy Detail

Historical Energy Use: N

BCTD DB129.1 and DB129.2 - San Francisco County, Annual

5.3 Energy by Land Use - Electricity

Mitigated

Land Use	Electricity Use kWh/yr	Total CO2	CH4	N2O	CO2e
User Defined Industrial	0	0.0000	0.0000	0.0000	0.0000
Total		0.0000	0.0000	0.0000	0.0000

6.0 Area Detail

6.1 Mitigation Measures Area

Category	tons/yr																
	ROG	NOx	CO	SO2	Fugitive PM10	Exhaust PM10	PM10 Total	Fugitive PM2.5	Exhaust PM2.5	PM2.5 Total	Bio- CO2	NBio- CO2	Total CO2	CH4	N2O	CO2e	
Mitigated	0.0000	0.0000	1.0000e-005	0.0000	0.0000	0.0000	0.0000	0.0000	0.0000	0.0000	0.0000	2.0000e-005	2.0000e-005	0.0000	0.0000	0.0000	2.0000e-005
Unmitigated	0.0000	0.0000	1.0000e-005	0.0000	0.0000	0.0000	0.0000	0.0000	0.0000	0.0000	0.0000	2.0000e-005	2.0000e-005	0.0000	0.0000	0.0000	2.0000e-005

BCTD DB129.1 and DB129.2 - San Francisco County, Annual

6.2 Area by SubCategory

Unmitigated

SubCategory	tons/yr										MT/yr					
	ROG	NOx	CO	SO2	Fugitive PM10	Exhaust PM10	PM10 Total	Fugitive PM2.5	Exhaust PM2.5	PM2.5 Total	Bio- CO2	NBio- CO2	Total CO2	CH4	N2O	CO2e
Architectural Coating	0.0000					0.0000	0.0000	0.0000	0.0000	0.0000	0.0000	0.0000	0.0000	0.0000	0.0000	0.0000
Consumer Products	0.0000					0.0000	0.0000	0.0000	0.0000	0.0000	0.0000	0.0000	0.0000	0.0000	0.0000	0.0000
Landscaping	0.0000	0.0000	1.0000e-005	0.0000		0.0000	0.0000	0.0000	0.0000	0.0000	0.0000	2.0000e-005	2.0000e-005	0.0000	0.0000	2.0000e-005
Total	0.0000	0.0000	1.0000e-005	0.0000		0.0000	0.0000	0.0000	0.0000	0.0000	0.0000	2.0000e-005	2.0000e-005	0.0000	0.0000	2.0000e-005

Mitigated

SubCategory	tons/yr										MT/yr					
	ROG	NOx	CO	SO2	Fugitive PM10	Exhaust PM10	PM10 Total	Fugitive PM2.5	Exhaust PM2.5	PM2.5 Total	Bio- CO2	NBio- CO2	Total CO2	CH4	N2O	CO2e
Architectural Coating	0.0000					0.0000	0.0000	0.0000	0.0000	0.0000	0.0000	0.0000	0.0000	0.0000	0.0000	0.0000
Consumer Products	0.0000					0.0000	0.0000	0.0000	0.0000	0.0000	0.0000	0.0000	0.0000	0.0000	0.0000	0.0000
Landscaping	0.0000	0.0000	1.0000e-005	0.0000		0.0000	0.0000	0.0000	0.0000	0.0000	0.0000	2.0000e-005	2.0000e-005	0.0000	0.0000	2.0000e-005
Total	0.0000	0.0000	1.0000e-005	0.0000		0.0000	0.0000	0.0000	0.0000	0.0000	0.0000	2.0000e-005	2.0000e-005	0.0000	0.0000	2.0000e-005

7.0 Water Detail

7.1 Mitigation Measures Water

	Total CO2	CH4	N2O	CO2e
Category	MT/yr			
Mitigated	0.0000	0.0000	0.0000	0.0000
Unmitigated	0.0000	0.0000	0.0000	0.0000

7.2 Water by Land Use

Unmitigated

	Indoor/Outdoor Use	Total CO2	CH4	N2O	CO2e
Land Use	Mgal				
User Defined Industrial	0 / 0	0.0000	0.0000	0.0000	0.0000
Total		0.0000	0.0000	0.0000	0.0000

BCTD DB129.1 and DB129.2 - San Francisco County, Annual

7.2 Water by Land Use

Mitigated

Land Use	Indoor/Outdoor Use	Total CO2	CH4	N2O	CO2e
	Mgal	MT/yr			
User Defined Industrial	0 / 0	0.0000	0.0000	0.0000	0.0000
Total		0.0000	0.0000	0.0000	0.0000

8.0 Waste Detail

8.1 Mitigation Measures Waste

Category/Year

Category/Year	Total CO2	CH4	N2O	CO2e
	MT/yr			
Mitigated	0.0000	0.0000	0.0000	0.0000
Unmitigated	0.0000	0.0000	0.0000	0.0000

BCTD DB129.1 and DB129.2 - San Francisco County, Annual

8.2 Waste by Land Use

Unmitigated

Land Use	Waste Disposed tons	MT/yr			
		Total CO2	CH4	N2O	CO2e
User Defined Industrial	0	0.0000	0.0000	0.0000	0.0000
Total		0.0000	0.0000	0.0000	0.0000

Mitigated

Land Use	Waste Disposed tons	MT/yr			
		Total CO2	CH4	N2O	CO2e
User Defined Industrial	0	0.0000	0.0000	0.0000	0.0000
Total		0.0000	0.0000	0.0000	0.0000

9.0 Operational Offroad

Equipment Type	Number	Hours/Day	Days/Year	Horse Power	Load Factor	Fuel Type

BCTD DB129.1 and DB129.2 - San Francisco County, Annual

10.0 Stationary Equipment

Fire Pumps and Emergency Generators

Equipment Type	Number	Hours/Day	Hours/Year	Horse Power	Load Factor	Fuel Type
----------------	--------	-----------	------------	-------------	-------------	-----------

Boilers

Equipment Type	Number	Heat Input/Day	Heat Input/Year	Boiler Rating	Fuel Type
----------------	--------	----------------	-----------------	---------------	-----------

User Defined Equipment

Equipment Type	Number
----------------	--------

11.0 Vegetation

BCTD DB129.1 and DB129.2 - San Francisco County, Annual

**BCTD DB129.1 and DB129.2
San Francisco County, Annual**

1.0 Project Characteristics

1.1 Land Usage

Land Uses	Size	Metric	Lot Acreage	Floor Surface Area	Population
User Defined Industrial	1.00	User Defined Unit	1.32	0.00	0

1.2 Other Project Characteristics

Urbanization	Urban	Wind Speed (m/s)	4.6	Precipitation Freq (Days)	64
Climate Zone	5			Operational Year	2021

Utility Company Pacific Gas & Electric Company

CO2 Intensity (lb/MW/hr)	641.35	CH4 Intensity (lb/MW/hr)	0.029	N2O Intensity (lb/MW/hr)	0.006
---------------------------------	--------	---------------------------------	-------	---------------------------------	-------

1.3 User Entered Comments & Non-Default Data

Project Characteristics -

Land Use - Project specific acreage based on trenching limits.

Construction Phase - Project specific construction schedule.

Off-road Equipment - Equipment entered in one phase.

Off-road Equipment - Project specific construction equipment. Asphalt truck modeled as off-highway truck.

Trips and VMT - Assumes approx. 15 workers per day. Vendor trips account for concrete trucks placing approx. 3,360 CY total, using 8-CY capacity trucks. Haul truck trips based on 16-CY capacity trucks.

Grading - Default acres graded. Approx. 40,530 CY material export and 32,315 CY material import.

Construction Off-road Equipment Mitigation - Assumes fugitive dust control and use of Tier 2 engines with Level 3 DPF. Generator assumed to be electric.

BCTD DB129.1 and DB129.2 - San Francisco County, Annual

Table Name	Column Name	Default Value	New Value
tblConstEquipMitigation	DPF	No Change	Level 3
tblConstEquipMitigation	DPF	No Change	Level 3
tblConstEquipMitigation	DPF	No Change	Level 3
tblConstEquipMitigation	DPF	No Change	Level 3
tblConstEquipMitigation	DPF	No Change	Level 3
tblConstEquipMitigation	DPF	No Change	Level 3
tblConstEquipMitigation	DPF	No Change	Level 3
tblConstEquipMitigation	FuelType	Diesel	Electrical
tblConstEquipMitigation	NumberOfEquipmentMitigated	0.00	1.00
tblConstEquipMitigation	NumberOfEquipmentMitigated	0.00	1.00
tblConstEquipMitigation	NumberOfEquipmentMitigated	0.00	1.00
tblConstEquipMitigation	NumberOfEquipmentMitigated	0.00	1.00
tblConstEquipMitigation	NumberOfEquipmentMitigated	0.00	2.00
tblConstEquipMitigation	NumberOfEquipmentMitigated	0.00	1.00
tblConstEquipMitigation	NumberOfEquipmentMitigated	0.00	1.00
tblConstEquipMitigation	NumberOfEquipmentMitigated	0.00	1.00
tblConstEquipMitigation	Tier	No Change	Tier 2
tblConstEquipMitigation	Tier	No Change	Tier 2
tblConstEquipMitigation	Tier	No Change	Tier 2
tblConstEquipMitigation	Tier	No Change	Tier 2
tblConstEquipMitigation	Tier	No Change	Tier 2
tblConstEquipMitigation	Tier	No Change	Tier 2
tblConstEquipMitigation	Tier	No Change	Tier 2
tblConstructionPhase	NumDays	10.00	1.00
tblConstructionPhase	NumDays	4.00	176.00
tblGrading	AcresOfGrading	0.00	1.50

BCTD DB129.1 and DB129.2 - San Francisco County, Annual

tblGrading	MaterialExported	0.00	40,530.00
tblGrading	MaterialImported	0.00	32,315.00
tblLandUse	LotAcreage	0.00	1.32
tblOffRoadEquipment	OffRoadEquipmentUnitAmount	1.00	0.00
tblOffRoadEquipment	OffRoadEquipmentUnitAmount	1.00	0.00
tblOffRoadEquipment	OffRoadEquipmentUnitAmount	1.00	0.00
tblOffRoadEquipment	UsageHours	6.00	0.00
tblOffRoadEquipment	UsageHours	6.00	0.00
tblOffRoadEquipment	UsageHours	6.00	0.00
tblOffRoadEquipment	UsageHours	7.00	8.00
tblTripsAndVMT	HaulingTripNumber	9,359.00	9,106.00
tblTripsAndVMT	VendorTripNumber	0.00	4.00
tblTripsAndVMT	WorkerTripNumber	23.00	30.00

2.0 Emissions Summary

BCTD DB129.1 and DB129.2 - San Francisco County, Annual

**2.1 Overall Construction
Unmitigated Construction**

Year	tons/yr											MT/yr				
	ROG	NOx	CO	SO2	Fugitive PM10	Exhaust PM10	PM10 Total	Fugitive PM2.5	Exhaust PM2.5	PM2.5 Total	Bio- CO2	NBio- CO2	Total CO2	CH4	N2O	CO2e
2020	0.1372	2.3806	1.4365	5.2500e-003	0.1058	0.0544	0.1602	0.0273	0.0511	0.0784	0.0000	524.4976	524.4976	0.1029	0.0000	527.0706
2021	0.0179	0.3091	0.2048	7.4000e-004	0.0743	6.6700e-003	0.0810	0.0175	6.2700e-003	0.0237	0.0000	73.9217	73.9217	0.0147	0.0000	74.2898
Maximum	0.1372	2.3806	1.4365	5.2500e-003	0.1058	0.0544	0.1602	0.0273	0.0511	0.0784	0.0000	524.4976	524.4976	0.1029	0.0000	527.0706

Mitigated Construction

Year	tons/yr											MT/yr				
	ROG	NOx	CO	SO2	Fugitive PM10	Exhaust PM10	PM10 Total	Fugitive PM2.5	Exhaust PM2.5	PM2.5 Total	Bio- CO2	NBio- CO2	Total CO2	CH4	N2O	CO2e
2020	0.0929	2.6256	1.4450	5.2500e-003	0.0995	0.0103	0.1098	0.0263	0.0101	0.0365	0.0000	502.7369	502.7369	0.1017	0.0000	505.2793
2021	0.0130	0.3601	0.2073	7.4000e-004	0.0680	1.4100e-003	0.0694	0.0165	1.3800e-003	0.0179	0.0000	70.8130	70.8130	0.0146	0.0000	71.1771
Maximum	0.0929	2.6256	1.4450	5.2500e-003	0.0995	0.0103	0.1098	0.0263	0.0101	0.0365	0.0000	502.7369	502.7369	0.1017	0.0000	505.2793

Percent Reduction	tons/yr											MT/yr				
	ROG	NOx	CO	SO2	Fugitive PM10	Exhaust PM10	PM10 Total	Fugitive PM2.5	Exhaust PM2.5	PM2.5 Total	Bio- CO2	NBio- CO2	Total CO2	CH4	N2O	CO2e
	31.73	-11.00	-0.67	0.00	7.04	80.78	25.72	4.23	79.94	46.77	0.00	4.16	4.16	1.17	0.00	4.14

BCTD DB129.1 and DB129.2 - San Francisco County, Annual

Quarter	Start Date	End Date	Maximum Unmitigated ROG + NOX (tons/quarter)	Maximum Mitigated ROG + NOX (tons/quarter)
1	6-1-2020	8-31-2020	1.0591	1.1447
2	9-1-2020	11-30-2020	1.0598	1.1445
3	12-1-2020	2-28-2021	0.7038	0.7804
		Highest	1.0598	1.1447

**2.2 Overall Operational
Unmitigated Operational**

Category	tons/yr											MT/yr						
	ROG	NOx	CO	SO2	Fugitive PM10	Exhaust PM10	PM10 Total	Fugitive PM2.5	Exhaust PM2.5	PM2.5 Total	Bio- CO2	NBio- CO2	Total CO2	CH4	N2O	CO2e		
Area	0.0000	0.0000	1.0000e-005	0.0000	0.0000	0.0000	0.0000	0.0000	0.0000	0.0000	0.0000	2.0000e-005	2.0000e-005	0.0000	0.0000	0.0000	2.0000e-005	
Energy	0.0000	0.0000	0.0000	0.0000	0.0000	0.0000	0.0000	0.0000	0.0000	0.0000	0.0000	0.0000	0.0000	0.0000	0.0000	0.0000	0.0000	
Mobile	0.0000	0.0000	0.0000	0.0000	0.0000	0.0000	0.0000	0.0000	0.0000	0.0000	0.0000	0.0000	0.0000	0.0000	0.0000	0.0000	0.0000	
Waste																		
Water																		
Total	0.0000	0.0000	1.0000e-005	0.0000	0.0000	0.0000	0.0000	0.0000	0.0000	0.0000	0.0000	2.0000e-005	2.0000e-005	0.0000	0.0000	0.0000	2.0000e-005	

BCTD DB129.1 and DB129.2 - San Francisco County, Annual

**2.2 Overall Operational
Mitigated Operational**

Category	tons/yr											MT/yr				
	ROG	NOx	CO	SO2	Fugitive PM10	Exhaust PM10	PM10 Total	Fugitive PM2.5	Exhaust PM2.5	PM2.5 Total	Bio- CO2	NBio- CO2	Total CO2	CH4	N2O	CO2e
Area	0.0000	0.0000	1.0000e-005	0.0000	0.0000	0.0000	0.0000	0.0000	0.0000	0.0000	0.0000	2.0000e-005	2.0000e-005	0.0000	0.0000	2.0000e-005
Energy	0.0000	0.0000	0.0000	0.0000	0.0000	0.0000	0.0000	0.0000	0.0000	0.0000	0.0000	0.0000	0.0000	0.0000	0.0000	0.0000
Mobile	0.0000	0.0000	0.0000	0.0000	0.0000	0.0000	0.0000	0.0000	0.0000	0.0000	0.0000	0.0000	0.0000	0.0000	0.0000	0.0000
Waste																
Water																
Total	0.0000	0.0000	1.0000e-005	0.0000	0.0000	0.0000	0.0000	0.0000	0.0000	0.0000	0.0000	2.0000e-005	2.0000e-005	0.0000	0.0000	2.0000e-005

Percent Reduction	ROG		NOx		CO		SO2		Fugitive PM10		Exhaust PM10		PM10 Total		Fugitive PM2.5		Exhaust PM2.5		PM2.5 Total		Bio- CO2		NBio- CO2		Total CO2		CH4		N2O		CO2e	
	0.00	0.00	0.00	0.00	0.00	0.00	0.00	0.00	0.00	0.00	0.00	0.00	0.00	0.00	0.00	0.00	0.00	0.00	0.00	0.00	0.00	0.00	0.00	0.00	0.00	0.00	0.00	0.00	0.00	0.00	0.00	

3.0 Construction Detail

Construction Phase

Phase Number	Phase Name	Phase Type	Start Date	End Date	Num Days Week	Num Days	Phase Description
1	Grading	Grading	6/1/2020	2/1/2021	5	176	
2	Architectural Coating	Architectural Coating	6/5/2020	6/5/2020	5	1	

BCTD DB129.1 and DB129.2 - San Francisco County, Annual

Acres of Grading (Site Preparation Phase): 0

Acres of Grading (Grading Phase): 1.5

Acres of Paving: 0

Residential Indoor: 0; Residential Outdoor: 0; Non-Residential Indoor: 0; Non-Residential Outdoor: 0; Striped Parking Area: 0 (Architectural Coating – sqft)

OffRoad Equipment

Phase Name	Offroad Equipment Type	Amount	Usage Hours	Horse Power	Load Factor
Grading	Concrete/Industrial Saws	1	2.00	81	0.73
Grading	Excavators	1	8.00	158	0.38
Grading	Generator Sets	1	4.00	84	0.74
Grading	Graders	0	0.00	187	0.41
Grading	Off-Highway Trucks	1	2.00	402	0.38
Grading	Other Construction Equipment	2	2.00	172	0.42
Grading	Rollers	1	2.00	80	0.38
Grading	Rubber Tired Dozers	0	0.00	247	0.40
Grading	Skid Steer Loaders	1	4.00	65	0.37
Grading	Tractors/Loaders/Backhoes	1	8.00	97	0.37
Architectural Coating	Air Compressors	0	0.00	78	0.48

Trips and VMT

Phase Name	Offroad Equipment Count	Worker Trip Number	Vendor Trip Number	Hauling Trip Number	Worker Trip Length	Vendor Trip Length	Hauling Trip Length	Worker Vehicle Class	Vendor Vehicle Class	Hauling Vehicle Class
Grading	9	30.00	4.00	9,106.00	10.80	7.30	20.00	LD_Mix	HDT_Mix	HHDT
Architectural Coating	0	0.00	0.00	0.00	10.80	7.30	20.00	LD_Mix	HDT_Mix	HHDT

3.1 Mitigation Measures Construction

BCTD DB129.1 and DB129.2 - San Francisco County, Annual

- Use Alternative Fuel for Construction Equipment
- Use Cleaner Engines for Construction Equipment
- Use DPF for Construction Equipment
- Water Exposed Area

3.2 Grading - 2020

Unmitigated Construction On-Site

Category	tons/yr											MT/yr				
	ROG	NOx	CO	SO2	Fugitive PM10	Exhaust PM10	PM10 Total	Fugitive PM2.5	Exhaust PM2.5	PM2.5 Total	Bio- CO2	NBio- CO2	Total CO2	CH4	N2O	CO2e
Fugitive Dust					0.0115	0.0000	0.0115	1.7100e-003	0.0000	1.7100e-003	0.0000	0.0000	0.0000	0.0000	0.0000	0.0000
Off-Road	0.0973	0.9497	0.9628	1.6300e-003		0.0500	0.0500		0.0469	0.0469	0.0000	142.7261	142.7261	0.0377	0.0000	143.6675
Total	0.0973	0.9497	0.9628	1.6300e-003	0.0115	0.0500	0.0616	1.7100e-003	0.0469	0.0486	0.0000	142.7261	142.7261	0.0377	0.0000	143.6675

BCTD DB129.1 and DB129.2 - San Francisco County, Annual

3.2 Grading - 2020

Unmitigated Construction Off-Site

Category	tons/yr										MT/yr					
	ROG	NOx	CO	SO2	Fugitive PM10	Exhaust PM10	PM10 Total	Fugitive PM2.5	Exhaust PM2.5	PM2.5 Total	Bio- CO2	NBio- CO2	Total CO2	CH4	N2O	CO2e
Hauling	0.0318	1.3877	0.4104	3.3400e-003	0.0740	4.0800e-003	0.0781	0.0201	3.9000e-003	0.0240	0.0000	355.8977	355.8977	0.0638	0.0000	357.4914
Vendor	1.1300e-003	0.0386	0.0114	8.0000e-005	2.0100e-003	1.7000e-004	2.1800e-003	5.8000e-004	1.6000e-004	7.4000e-004	0.0000	8.5258	8.5258	1.1400e-003	0.0000	8.5542
Worker	7.0200e-003	4.6700e-003	0.0519	1.9000e-004	0.0183	1.4000e-004	0.0184	4.8600e-003	1.3000e-004	4.9900e-003	0.0000	17.3480	17.3480	3.8000e-004	0.0000	17.3575
Total	0.0399	1.4310	0.4737	3.6100e-003	0.0943	4.3900e-003	0.0987	0.0256	4.1900e-003	0.0297	0.0000	381.7714	381.7714	0.0653	0.0000	383.4030

Mitigated Construction On-Site

Category	tons/yr										MT/yr					
	ROG	NOx	CO	SO2	Fugitive PM10	Exhaust PM10	PM10 Total	Fugitive PM2.5	Exhaust PM2.5	PM2.5 Total	Bio- CO2	NBio- CO2	Total CO2	CH4	N2O	CO2e
Fugitive Dust					5.1900e-003	0.0000	5.1900e-003	7.7000e-004	0.0000	7.7000e-004	0.0000	0.0000	0.0000	0.0000	0.0000	0.0000
Off-Road	0.0530	1.1946	0.9713	1.6300e-003	5.9400e-003	5.9400e-003	5.9400e-003	5.9400e-003	5.9400e-003	5.9400e-003	0.0000	120.9655	120.9655	0.0364	0.0000	121.8763
Total	0.0530	1.1946	0.9713	1.6300e-003	5.1900e-003	5.9400e-003	0.0111	7.7000e-004	5.9400e-003	6.7100e-003	0.0000	120.9655	120.9655	0.0364	0.0000	121.8763

BCTD DB129.1 and DB129.2 - San Francisco County, Annual

3.2 Grading - 2020

Mitigated Construction Off-Site

Category	tons/yr										MT/yr					
	ROG	NOx	CO	SO2	Fugitive PM10	Exhaust PM10	PM10 Total	Fugitive PM2.5	Exhaust PM2.5	PM2.5 Total	Bio- CO2	NBio- CO2	Total CO2	CH4	N2O	CO2e
Hauling	0.0318	1.3877	0.4104	3.3400e-003	0.0740	4.0800e-003	0.0781	0.0201	3.9000e-003	0.0240	0.0000	355.8977	355.8977	0.0638	0.0000	357.4914
Vendor	1.1300e-003	0.0386	0.0114	8.0000e-005	2.0100e-003	1.7000e-004	2.1800e-003	5.8000e-004	1.6000e-004	7.4000e-004	0.0000	8.5258	8.5258	1.1400e-003	0.0000	8.5542
Worker	7.0200e-003	4.6700e-003	0.0519	1.9000e-004	0.0183	1.4000e-004	0.0184	4.8600e-003	1.3000e-004	4.9900e-003	0.0000	17.3480	17.3480	3.8000e-004	0.0000	17.3575
Total	0.0399	1.4310	0.4737	3.6100e-003	0.0943	4.3900e-003	0.0987	0.0256	4.1900e-003	0.0297	0.0000	381.7714	381.7714	0.0653	0.0000	383.4030

3.2 Grading - 2021

Unmitigated Construction On-Site

Category	tons/yr										MT/yr					
	ROG	NOx	CO	SO2	Fugitive PM10	Exhaust PM10	PM10 Total	Fugitive PM2.5	Exhaust PM2.5	PM2.5 Total	Bio- CO2	NBio- CO2	Total CO2	CH4	N2O	CO2e
Fugitive Dust					0.0115	0.0000	0.0115	1.7100e-003	0.0000	1.7100e-003	0.0000	0.0000	0.0000	0.0000	0.0000	0.0000
Off-Road	0.0125	0.1197	0.1363	2.3000e-004		6.1200e-003	6.1200e-003	5.7400e-003	5.7400e-003	5.7400e-003	0.0000	20.3901	20.3901	5.3600e-003	0.0000	20.5239
Total	0.0125	0.1197	0.1363	2.3000e-004	0.0115	6.1200e-003	0.0177	1.7100e-003	5.7400e-003	7.4500e-003	0.0000	20.3901	20.3901	5.3600e-003	0.0000	20.5239

BCTD DB129.1 and DB129.2 - San Francisco County, Annual

3.2 Grading - 2021

Unmitigated Construction Off-Site

Category	tons/yr										MT/yr					
	ROG	NOx	CO	SO2	Fugitive PM10	Exhaust PM10	PM10 Total	Fugitive PM2.5	Exhaust PM2.5	PM2.5 Total	Bio- CO2	NBio- CO2	Total CO2	CH4	N2O	CO2e
Hauling	4.3100e-003	0.1838	0.0601	4.7000e-004	0.0599	5.3000e-004	0.0604	0.0150	5.0000e-004	0.0155	0.0000	49.9394	49.9394	9.1600e-003	0.0000	50.1684
Vendor	1.3000e-004	5.0400e-003	1.5400e-003	1.0000e-005	2.9000e-004	1.0000e-005	3.0000e-004	8.0000e-005	1.0000e-005	9.0000e-005	0.0000	1.2025	1.2025	1.6000e-004	0.0000	1.2065
Worker	9.4000e-004	6.0000e-004	6.8800e-003	3.0000e-005	2.6100e-003	2.0000e-005	2.6300e-003	6.9000e-004	2.0000e-005	7.1000e-004	0.0000	2.3898	2.3898	5.0000e-005	0.0000	2.3910
Total	5.3800e-003	0.1894	0.0685	5.1000e-004	0.0628	5.6000e-004	0.0634	0.0158	5.3000e-004	0.0163	0.0000	53.5316	53.5316	9.3700e-003	0.0000	53.7658

Mitigated Construction On-Site

Category	tons/yr										MT/yr					
	ROG	NOx	CO	SO2	Fugitive PM10	Exhaust PM10	PM10 Total	Fugitive PM2.5	Exhaust PM2.5	PM2.5 Total	Bio- CO2	NBio- CO2	Total CO2	CH4	N2O	CO2e
Fugitive Dust					5.1900e-003	0.0000	5.1900e-003	7.7000e-004	0.0000	7.7000e-004	0.0000	0.0000	0.0000	0.0000	0.0000	0.0000
Off-Road	7.5700e-003	0.1707	0.1388	2.3000e-004	8.5000e-004	8.5000e-004	8.5000e-004	8.5000e-004	8.5000e-004	8.5000e-004	0.0000	17.2814	17.2814	5.2000e-003	0.0000	17.4113
Total	7.5700e-003	0.1707	0.1388	2.3000e-004	5.1900e-003	8.5000e-004	6.0400e-003	7.7000e-004	8.5000e-004	1.6200e-003	0.0000	17.2814	17.2814	5.2000e-003	0.0000	17.4113

BCTD DB129.1 and DB129.2 - San Francisco County, Annual

3.3 Architectural Coating - 2020

Mitigated Construction Off-Site

Category	tons/yr										MT/yr						
	ROG	NOx	CO	SO2	Fugitive PM10	Exhaust PM10	PM10 Total	Fugitive PM2.5	Exhaust PM2.5	PM2.5 Total	Bio- CO2	NBio- CO2	Total CO2	CH4	N2O	CO2e	
Hauling	0.0000	0.0000	0.0000	0.0000	0.0000	0.0000	0.0000	0.0000	0.0000	0.0000	0.0000	0.0000	0.0000	0.0000	0.0000	0.0000	0.0000
Vendor	0.0000	0.0000	0.0000	0.0000	0.0000	0.0000	0.0000	0.0000	0.0000	0.0000	0.0000	0.0000	0.0000	0.0000	0.0000	0.0000	0.0000
Worker	0.0000	0.0000	0.0000	0.0000	0.0000	0.0000	0.0000	0.0000	0.0000	0.0000	0.0000	0.0000	0.0000	0.0000	0.0000	0.0000	0.0000
Total	0.0000	0.0000	0.0000	0.0000	0.0000	0.0000	0.0000	0.0000	0.0000	0.0000	0.0000	0.0000	0.0000	0.0000	0.0000	0.0000	0.0000

4.0 Operational Detail - Mobile

4.1 Mitigation Measures Mobile

BCTD DB129.1 and DB129.2 - San Francisco County, Annual

Category	tons/yr													MT/yr			
	ROG	NOx	CO	SO2	Fugitive PM10	Exhaust PM10	PM10 Total	Fugitive PM2.5	Exhaust PM2.5	PM2.5 Total	Bio- CO2	NBio- CO2	Total CO2	CH4	N2O	CO2e	
Mitigated	0.0000	0.0000	0.0000	0.0000	0.0000	0.0000	0.0000	0.0000	0.0000	0.0000	0.0000	0.0000	0.0000	0.0000	0.0000	0.0000	
Unmitigated	0.0000	0.0000	0.0000	0.0000	0.0000	0.0000	0.0000	0.0000	0.0000	0.0000	0.0000	0.0000	0.0000	0.0000	0.0000	0.0000	

4.2 Trip Summary Information

Land Use	Average Daily Trip Rate			Unmitigated		Mitigated	
	Weekday	Saturday	Sunday	Annual VMT	Annual VMT	Annual VMT	Annual VMT
User Defined Industrial	0.00	0.00	0.00				
Total	0.00	0.00	0.00				

4.3 Trip Type Information

Land Use	Miles						Trip %			Trip Purpose %		
	H-W or C-C	H-S or C-C	H-O or C-NW	H-W or C-W	H-S or C-C	H-O or C-NW	Primary	Diverted	Pass-by	Primary	Diverted	Pass-by
User Defined Industrial	9.50	7.30	7.30	0.00	0.00	0.00	0	0	0	0	0	0

4.4 Fleet Mix

Land Use	LDA	LDT1	LDT2	MDV	LHD1	LHD2	MHD	HHD	OBUS	UBUS	MCY	SBUS	MH
User Defined Industrial	0.606408	0.040118	0.191445	0.088323	0.014900	0.004926	0.028280	0.008891	0.004289	0.004272	0.006741	0.000931	0.000477

5.0 Energy Detail

Historical Energy Use: N

BCTD DB129.1 and DB129.2 - San Francisco County, Annual

5.3 Energy by Land Use - Electricity

Mitigated

Land Use	Electricity Use kWh/yr	Total CO2	CH4	N2O	CO2e
User Defined Industrial	0	0.0000	0.0000	0.0000	0.0000
Total		0.0000	0.0000	0.0000	0.0000

6.0 Area Detail

6.1 Mitigation Measures Area

Category	tons/yr																
	ROG	NOx	CO	SO2	Fugitive PM10	Exhaust PM10	PM10 Total	Fugitive PM2.5	Exhaust PM2.5	PM2.5 Total	Bio- CO2	NBio- CO2	Total CO2	CH4	N2O	CO2e	
Mitigated	0.0000	0.0000	1.0000e-005	0.0000	0.0000	0.0000	0.0000	0.0000	0.0000	0.0000	0.0000	2.0000e-005	2.0000e-005	0.0000	0.0000	0.0000	2.0000e-005
Unmitigated	0.0000	0.0000	1.0000e-005	0.0000	0.0000	0.0000	0.0000	0.0000	0.0000	0.0000	0.0000	2.0000e-005	2.0000e-005	0.0000	0.0000	0.0000	2.0000e-005

BCTD DB129.1 and DB129.2 - San Francisco County, Annual

6.2 Area by SubCategory

Unmitigated

SubCategory	tons/yr										MT/yr					
	ROG	NOx	CO	SO2	Fugitive PM10	Exhaust PM10	PM10 Total	Fugitive PM2.5	Exhaust PM2.5	PM2.5 Total	Bio- CO2	NBio- CO2	Total CO2	CH4	N2O	CO2e
Architectural Coating	0.0000					0.0000	0.0000	0.0000	0.0000	0.0000	0.0000	0.0000	0.0000	0.0000	0.0000	0.0000
Consumer Products	0.0000					0.0000	0.0000	0.0000	0.0000	0.0000	0.0000	0.0000	0.0000	0.0000	0.0000	0.0000
Landscaping	0.0000	0.0000	1.0000e-005	0.0000		0.0000	0.0000	0.0000	0.0000	0.0000	0.0000	2.0000e-005	2.0000e-005	0.0000	0.0000	2.0000e-005
Total	0.0000	0.0000	1.0000e-005	0.0000		0.0000	0.0000	0.0000	0.0000	0.0000	0.0000	2.0000e-005	2.0000e-005	0.0000	0.0000	2.0000e-005

Mitigated

SubCategory	tons/yr										MT/yr					
	ROG	NOx	CO	SO2	Fugitive PM10	Exhaust PM10	PM10 Total	Fugitive PM2.5	Exhaust PM2.5	PM2.5 Total	Bio- CO2	NBio- CO2	Total CO2	CH4	N2O	CO2e
Architectural Coating	0.0000					0.0000	0.0000	0.0000	0.0000	0.0000	0.0000	0.0000	0.0000	0.0000	0.0000	0.0000
Consumer Products	0.0000					0.0000	0.0000	0.0000	0.0000	0.0000	0.0000	0.0000	0.0000	0.0000	0.0000	0.0000
Landscaping	0.0000	0.0000	1.0000e-005	0.0000		0.0000	0.0000	0.0000	0.0000	0.0000	0.0000	2.0000e-005	2.0000e-005	0.0000	0.0000	2.0000e-005
Total	0.0000	0.0000	1.0000e-005	0.0000		0.0000	0.0000	0.0000	0.0000	0.0000	0.0000	2.0000e-005	2.0000e-005	0.0000	0.0000	2.0000e-005

7.0 Water Detail

7.1 Mitigation Measures Water

	Total CO2	CH4	N2O	CO2e
Category	MT/yr			
Mitigated	0.0000	0.0000	0.0000	0.0000
Unmitigated	0.0000	0.0000	0.0000	0.0000

7.2 Water by Land Use

Unmitigated

	Indoor/Outdoor Use	Total CO2	CH4	N2O	CO2e
Land Use	Mgal				
User Defined Industrial	0 / 0	0.0000	0.0000	0.0000	0.0000
Total		0.0000	0.0000	0.0000	0.0000

BCTD DB129.1 and DB129.2 - San Francisco County, Annual

7.2 Water by Land Use

Mitigated

Land Use	Indoor/Outdoor Use	Total CO2	CH4	N2O	CO2e
	Mgal	MT/yr			
User Defined Industrial	0 / 0	0.0000	0.0000	0.0000	0.0000
Total		0.0000	0.0000	0.0000	0.0000

8.0 Waste Detail

8.1 Mitigation Measures Waste

Category/Year

Category/Year	Total CO2	CH4	N2O	CO2e
	MT/yr			
Mitigated	0.0000	0.0000	0.0000	0.0000
Unmitigated	0.0000	0.0000	0.0000	0.0000

BCTD DB129.1 and DB129.2 - San Francisco County, Annual

8.2 Waste by Land Use

Unmitigated

Land Use	Waste Disposed tons	Total CO2				CO2e
		CH4	N2O	MT/yr		
User Defined Industrial	0	0.0000	0.0000	0.0000	0.0000	0.0000
Total		0.0000	0.0000	0.0000	0.0000	0.0000

Mitigated

Land Use	Waste Disposed tons	Total CO2				CO2e
		CH4	N2O	MT/yr		
User Defined Industrial	0	0.0000	0.0000	0.0000	0.0000	0.0000
Total		0.0000	0.0000	0.0000	0.0000	0.0000

9.0 Operational Offroad

Equipment Type	Number	Hours/Day	Days/Year	Horse Power	Load Factor	Fuel Type
----------------	--------	-----------	-----------	-------------	-------------	-----------

BCTD DB129.1 and DB129.2 - San Francisco County, Annual

10.0 Stationary Equipment

Fire Pumps and Emergency Generators

Equipment Type	Number	Hours/Day	Hours/Year	Horse Power	Load Factor	Fuel Type
----------------	--------	-----------	------------	-------------	-------------	-----------

Boilers

Equipment Type	Number	Heat Input/Day	Heat Input/Year	Boiler Rating	Fuel Type
----------------	--------	----------------	-----------------	---------------	-----------

User Defined Equipment

Equipment Type	Number
----------------	--------

11.0 Vegetation

BCTD DB129.1 and DB129.2 - San Francisco County, Annual

**BCTD DB129.1 and DB129.2
San Francisco County, Annual**

1.0 Project Characteristics

1.1 Land Usage

Land Uses	Size	Metric	Lot Acreage	Floor Surface Area	Population
User Defined Industrial	1.00	User Defined Unit	1.32	0.00	0

1.2 Other Project Characteristics

Urbanization	Urban	Wind Speed (m/s)	4.6	Precipitation Freq (Days)	64
Climate Zone	5			Operational Year	2021

Utility Company Pacific Gas & Electric Company

CO2 Intensity (lb/MW/hr)	641.35	CH4 Intensity (lb/MW/hr)	0.029	N2O Intensity (lb/MW/hr)	0.006
---------------------------------	--------	---------------------------------	-------	---------------------------------	-------

1.3 User Entered Comments & Non-Default Data

Project Characteristics -

Land Use - Project specific acreage based on trenching limits.

Construction Phase - Project specific construction schedule.

Off-road Equipment - Equipment entered in one phase.

Off-road Equipment - Project specific construction equipment. Asphalt truck modeled as off-highway truck.

Trips and VMT - Assumes approx. 15 workers per day. Vendor trips account for concrete trucks placing approx. 3,360 CY total, using 8-CY capacity trucks. Haul truck trips based on 16-CY capacity trucks.

Grading - Default acres graded. Approx. 40,530 CY material export and 32,315 CY material import.

Construction Off-road Equipment Mitigation - Assumes fugitive dust control and use of Tier 4 final engines. Generator assumed to be electric.

BCTD DB129.1 and DB129.2 - San Francisco County, Annual

Table Name	Column Name	Default Value	New Value
tblConstEquipMitigation	FuelType	Diesel	Electrical
tblConstEquipMitigation	NumberOfEquipmentMitigated	0.00	1.00
tblConstEquipMitigation	NumberOfEquipmentMitigated	0.00	1.00
tblConstEquipMitigation	NumberOfEquipmentMitigated	0.00	1.00
tblConstEquipMitigation	NumberOfEquipmentMitigated	0.00	1.00
tblConstEquipMitigation	NumberOfEquipmentMitigated	0.00	2.00
tblConstEquipMitigation	NumberOfEquipmentMitigated	0.00	1.00
tblConstEquipMitigation	NumberOfEquipmentMitigated	0.00	1.00
tblConstEquipMitigation	NumberOfEquipmentMitigated	0.00	1.00
tblConstEquipMitigation	Tier	No Change	Tier 4 Final
tblConstEquipMitigation	Tier	No Change	Tier 4 Final
tblConstEquipMitigation	Tier	No Change	Tier 4 Final
tblConstEquipMitigation	Tier	No Change	Tier 4 Final
tblConstEquipMitigation	Tier	No Change	Tier 4 Final
tblConstEquipMitigation	Tier	No Change	Tier 4 Final
tblConstEquipMitigation	Tier	No Change	Tier 4 Final
tblConstructionPhase	NumDays	10.00	1.00
tblConstructionPhase	NumDays	4.00	176.00
tblGrading	AcresOfGrading	0.00	1.50
tblGrading	MaterialExported	0.00	40,530.00
tblGrading	MaterialImported	0.00	32,315.00
tblLandUse	LotAcreage	0.00	1.32
tblOffRoadEquipment	OffRoadEquipmentUnitAmount	1.00	0.00
tblOffRoadEquipment	OffRoadEquipmentUnitAmount	1.00	0.00
tblOffRoadEquipment	OffRoadEquipmentUnitAmount	1.00	0.00
tblOffRoadEquipment	UsageHours	6.00	0.00

BCTD DB129.1 and DB129.2 - San Francisco County, Annual

tblOffRoadEquipment	UsageHours	6.00	0.00
tblOffRoadEquipment	UsageHours	6.00	0.00
tblOffRoadEquipment	UsageHours	7.00	8.00
tblTripsAndVMT	HaulingTripNumber	9,359.00	9,106.00
tblTripsAndVMT	VendorTripNumber	0.00	4.00
tblTripsAndVMT	WorkerTripNumber	23.00	30.00

2.0 Emissions Summary

BCTD DB129.1 and DB129.2 - San Francisco County, Annual

2.1 Overall Construction
Unmitigated Construction

Year	tons/yr										MT/yr					
	ROG	NOx	CO	SO2	Fugitive PM10	Exhaust PM10	PM10 Total	Fugitive PM2.5	Exhaust PM2.5	PM2.5 Total	Bio- CO2	NBio- CO2	Total CO2	CH4	N2O	CO2e
2020	0.1372	2.3806	1.4365	5.2500e-003	0.1058	0.0544	0.1602	0.0273	0.0511	0.0784	0.0000	524.4976	524.4976	0.1029	0.0000	527.0706
2021	0.0179	0.3091	0.2048	7.4000e-004	0.0743	6.6700e-003	0.0810	0.0175	6.2700e-003	0.0237	0.0000	73.9217	73.9217	0.0147	0.0000	74.2898
Maximum	0.1372	2.3806	1.4365	5.2500e-003	0.1058	0.0544	0.1602	0.0273	0.0511	0.0784	0.0000	524.4976	524.4976	0.1029	0.0000	527.0706

Mitigated Construction

Year	tons/yr										MT/yr					
	ROG	NOx	CO	SO2	Fugitive PM10	Exhaust PM10	PM10 Total	Fugitive PM2.5	Exhaust PM2.5	PM2.5 Total	Bio- CO2	NBio- CO2	Total CO2	CH4	N2O	CO2e
2020	0.0576	1.5437	1.4242	5.2500e-003	0.0995	6.6100e-003	0.1061	0.0263	6.4200e-003	0.0327	0.0000	502.7369	502.7369	0.1017	0.0000	505.2793
2021	7.9100e-003	0.2055	0.2043	7.4000e-004	0.0680	8.8000e-004	0.0689	0.0165	8.5000e-004	0.0174	0.0000	70.8130	70.8130	0.0146	0.0000	71.1771
Maximum	0.0576	1.5437	1.4242	5.2500e-003	0.0995	6.6100e-003	0.1061	0.0263	6.4200e-003	0.0327	0.0000	502.7369	502.7369	0.1017	0.0000	505.2793

Percent Reduction	tons/yr										MT/yr					
	ROG	NOx	CO	SO2	Fugitive PM10	Exhaust PM10	PM10 Total	Fugitive PM2.5	Exhaust PM2.5	PM2.5 Total	Bio- CO2	NBio- CO2	Total CO2	CH4	N2O	CO2e
	57.77	34.97	0.78	0.00	7.04	87.74	27.48	4.23	87.33	50.93	0.00	4.16	4.16	1.17	0.00	4.14

BCTD DB129.1 and DB129.2 - San Francisco County, Annual

Quarter	Start Date	End Date	Maximum Unmitigated ROG + NOX (tons/quarter)	Maximum Mitigated ROG + NOX (tons/quarter)
1	6-1-2020	8-31-2020	1.0591	0.6680
2	9-1-2020	11-30-2020	1.0598	0.6730
3	12-1-2020	2-28-2021	0.7038	0.4540
		Highest	1.0598	0.6730

**2.2 Overall Operational
Unmitigated Operational**

Category	tons/yr										MT/yr					
	ROG	NOx	CO	SO2	Fugitive PM10	Exhaust PM10	PM10 Total	Fugitive PM2.5	Exhaust PM2.5	PM2.5 Total	Bio- CO2	NBio- CO2	Total CO2	CH4	N2O	CO2e
Area	0.0000	0.0000	1.0000e-005	0.0000	0.0000	0.0000	0.0000	0.0000	0.0000	0.0000	0.0000	2.0000e-005	2.0000e-005	0.0000	0.0000	2.0000e-005
Energy	0.0000	0.0000	0.0000	0.0000	0.0000	0.0000	0.0000	0.0000	0.0000	0.0000	0.0000	0.0000	0.0000	0.0000	0.0000	0.0000
Mobile	0.0000	0.0000	0.0000	0.0000	0.0000	0.0000	0.0000	0.0000	0.0000	0.0000	0.0000	0.0000	0.0000	0.0000	0.0000	0.0000
Waste																
Water																
Total	0.0000	0.0000	1.0000e-005	0.0000	0.0000	0.0000	0.0000	0.0000	0.0000	0.0000	0.0000	2.0000e-005	2.0000e-005	0.0000	0.0000	2.0000e-005

BCTD DB129.1 and DB129.2 - San Francisco County, Annual

**2.2 Overall Operational
Mitigated Operational**

Category	tons/yr											MT/yr					
	ROG	NOx	CO	SO2	Fugitive PM10	Exhaust PM10	PM10 Total	Fugitive PM2.5	Exhaust PM2.5	PM2.5 Total	Bio- CO2	NBio- CO2	Total CO2	CH4	N2O	CO2e	
Area	0.0000	0.0000	1.0000e-005	0.0000	0.0000	0.0000	0.0000	0.0000	0.0000	0.0000	0.0000	2.0000e-005	2.0000e-005	0.0000	0.0000	0.0000	2.0000e-005
Energy	0.0000	0.0000	0.0000	0.0000	0.0000	0.0000	0.0000	0.0000	0.0000	0.0000	0.0000	0.0000	0.0000	0.0000	0.0000	0.0000	0.0000
Mobile	0.0000	0.0000	0.0000	0.0000	0.0000	0.0000	0.0000	0.0000	0.0000	0.0000	0.0000	0.0000	0.0000	0.0000	0.0000	0.0000	0.0000
Waste																	
Water																	
Total	0.0000	0.0000	1.0000e-005	0.0000	0.0000	0.0000	0.0000	0.0000	0.0000	0.0000	0.0000	2.0000e-005	2.0000e-005	0.0000	0.0000	0.0000	2.0000e-005

Percent Reduction	tons/yr											MT/yr				
	ROG	NOx	CO	SO2	Fugitive PM10	Exhaust PM10	PM10 Total	Fugitive PM2.5	Exhaust PM2.5	PM2.5 Total	Bio- CO2	NBio- CO2	Total CO2	CH4	N2O	CO2e
0.00	0.00	0.00	0.00	0.00	0.00	0.00	0.00	0.00	0.00	0.00	0.00	0.00	0.00	0.00	0.00	0.00

3.0 Construction Detail

Construction Phase

Phase Number	Phase Name	Phase Type	Start Date	End Date	Num Days Week	Num Days	Phase Description
1	Grading	Grading	6/1/2020	2/1/2021	5	176	
2	Architectural Coating	Architectural Coating	6/5/2020	6/5/2020	5	1	

BCTD DB129.1 and DB129.2 - San Francisco County, Annual

Acres of Grading (Site Preparation Phase): 0

Acres of Grading (Grading Phase): 1.5

Acres of Paving: 0

Residential Indoor: 0; Residential Outdoor: 0; Non-Residential Indoor: 0; Non-Residential Outdoor: 0; Striped Parking Area: 0 (Architectural Coating – sqft)

OffRoad Equipment

Phase Name	Offroad Equipment Type	Amount	Usage Hours	Horse Power	Load Factor
Grading	Concrete/Industrial Saws	1	2.00	81	0.73
Grading	Excavators	1	8.00	158	0.38
Grading	Generator Sets	1	4.00	84	0.74
Grading	Graders	0	0.00	187	0.41
Grading	Off-Highway Trucks	1	2.00	402	0.38
Grading	Other Construction Equipment	2	2.00	172	0.42
Grading	Rollers	1	2.00	80	0.38
Grading	Rubber Tired Dozers	0	0.00	247	0.40
Grading	Skid Steer Loaders	1	4.00	65	0.37
Grading	Tractors/Loaders/Backhoes	1	8.00	97	0.37
Architectural Coating	Air Compressors	0	0.00	78	0.48

Trips and VMT

Phase Name	Offroad Equipment Count	Worker Trip Number	Vendor Trip Number	Hauling Trip Number	Worker Trip Length	Vendor Trip Length	Hauling Trip Length	Worker Vehicle Class	Vendor Vehicle Class	Hauling Vehicle Class
Grading	9	30.00	4.00	9,106.00	10.80	7.30	20.00	LD_Mix	HDT_Mix	HHDT
Architectural Coating	0	0.00	0.00	0.00	10.80	7.30	20.00	LD_Mix	HDT_Mix	HHDT

3.1 Mitigation Measures Construction

BCTD DB129.1 and DB129.2 - San Francisco County, Annual

Use Alternative Fuel for Construction Equipment
 Use Cleaner Engines for Construction Equipment
 Water Exposed Area

3.2 Grading - 2020

Unmitigated Construction On-Site

Category	tons/yr											MT/yr					
	ROG	NOx	CO	SO2	Fugitive PM10	Exhaust PM10	PM10 Total	Fugitive PM2.5	Exhaust PM2.5	PM2.5 Total	Bio- CO2	NBio- CO2	Total CO2	CH4	N2O	CO2e	
Fugitive Dust					0.0115	0.0000	0.0115	1.7100e-003	0.0000	1.7100e-003	0.0000	0.0000	0.0000	0.0000	0.0000	0.0000	0.0000
Off-Road	0.0973	0.9497	0.9628	1.6300e-003		0.0500	0.0500		0.0469	0.0469	0.0000	142.7261	142.7261	0.0377	0.0000	143.6675	
Total	0.0973	0.9497	0.9628	1.6300e-003	0.0115	0.0500	0.0616	1.7100e-003	0.0469	0.0486	0.0000	142.7261	142.7261	0.0377	0.0000	143.6675	

BCTD DB129.1 and DB129.2 - San Francisco County, Annual

3.2 Grading - 2020

Unmitigated Construction Off-Site

Category	tons/yr										MT/yr					
	ROG	NOx	CO	SO2	Fugitive PM10	Exhaust PM10	PM10 Total	Fugitive PM2.5	Exhaust PM2.5	PM2.5 Total	Bio- CO2	NBio- CO2	Total CO2	CH4	N2O	CO2e
Hauling	0.0318	1.3877	0.4104	3.3400e-003	0.0740	4.0800e-003	0.0781	0.0201	3.9000e-003	0.0240	0.0000	355.8977	355.8977	0.0638	0.0000	357.4914
Vendor	1.1300e-003	0.0386	0.0114	8.0000e-005	2.0100e-003	1.7000e-004	2.1800e-003	5.8000e-004	1.6000e-004	7.4000e-004	0.0000	8.5258	8.5258	1.1400e-003	0.0000	8.5542
Worker	7.0200e-003	4.6700e-003	0.0519	1.9000e-004	0.0183	1.4000e-004	0.0184	4.8600e-003	1.3000e-004	4.9900e-003	0.0000	17.3480	17.3480	3.8000e-004	0.0000	17.3575
Total	0.0399	1.4310	0.4737	3.6100e-003	0.0943	4.3900e-003	0.0987	0.0256	4.1900e-003	0.0297	0.0000	381.7714	381.7714	0.0653	0.0000	383.4030

Mitigated Construction On-Site

Category	tons/yr										MT/yr					
	ROG	NOx	CO	SO2	Fugitive PM10	Exhaust PM10	PM10 Total	Fugitive PM2.5	Exhaust PM2.5	PM2.5 Total	Bio- CO2	NBio- CO2	Total CO2	CH4	N2O	CO2e
Fugitive Dust					5.1900e-003	0.0000	5.1900e-003	7.7000e-004	0.0000	7.7000e-004	0.0000	0.0000	0.0000	0.0000	0.0000	0.0000
Off-Road	0.0177	0.1128	0.9505	1.6300e-003	2.2200e-003	2.2200e-003	2.2200e-003	2.2200e-003	2.2200e-003	2.2200e-003	0.0000	120.9655	120.9655	0.0364	0.0000	121.8763
Total	0.0177	0.1128	0.9505	1.6300e-003	5.1900e-003	2.2200e-003	7.4100e-003	7.7000e-004	2.2200e-003	2.9900e-003	0.0000	120.9655	120.9655	0.0364	0.0000	121.8763

BCTD DB129.1 and DB129.2 - San Francisco County, Annual

3.2 Grading - 2020

Mitigated Construction Off-Site

Category	tons/yr										MT/yr					
	ROG	NOx	CO	SO2	Fugitive PM10	Exhaust PM10	PM10 Total	Fugitive PM2.5	Exhaust PM2.5	PM2.5 Total	Bio- CO2	NBio- CO2	Total CO2	CH4	N2O	CO2e
Hauling	0.0318	1.3877	0.4104	3.3400e-003	0.0740	4.0800e-003	0.0781	0.0201	3.9000e-003	0.0240	0.0000	355.8977	355.8977	0.0638	0.0000	357.4914
Vendor	1.1300e-003	0.0386	0.0114	8.0000e-005	2.0100e-003	1.7000e-004	2.1800e-003	5.8000e-004	1.6000e-004	7.4000e-004	0.0000	8.5258	8.5258	1.1400e-003	0.0000	8.5542
Worker	7.0200e-003	4.6700e-003	0.0519	1.9000e-004	0.0183	1.4000e-004	0.0184	4.8600e-003	1.3000e-004	4.9900e-003	0.0000	17.3480	17.3480	3.8000e-004	0.0000	17.3575
Total	0.0399	1.4310	0.4737	3.6100e-003	0.0943	4.3900e-003	0.0987	0.0256	4.1900e-003	0.0297	0.0000	381.7714	381.7714	0.0653	0.0000	383.4030

3.2 Grading - 2021

Unmitigated Construction On-Site

Category	tons/yr										MT/yr					
	ROG	NOx	CO	SO2	Fugitive PM10	Exhaust PM10	PM10 Total	Fugitive PM2.5	Exhaust PM2.5	PM2.5 Total	Bio- CO2	NBio- CO2	Total CO2	CH4	N2O	CO2e
Fugitive Dust					0.0115	0.0000	0.0115	1.7100e-003	0.0000	1.7100e-003	0.0000	0.0000	0.0000	0.0000	0.0000	0.0000
Off-Road	0.0125	0.1197	0.1363	2.3000e-004		6.1200e-003	6.1200e-003	5.7400e-003	5.7400e-003	5.7400e-003	0.0000	20.3901	20.3901	5.3600e-003	0.0000	20.5239
Total	0.0125	0.1197	0.1363	2.3000e-004	0.0115	6.1200e-003	0.0177	1.7100e-003	5.7400e-003	7.4500e-003	0.0000	20.3901	20.3901	5.3600e-003	0.0000	20.5239

BCTD DB129.1 and DB129.2 - San Francisco County, Annual

3.2 Grading - 2021

Unmitigated Construction Off-Site

Category	tons/yr										MT/yr					
	ROG	NOx	CO	SO2	Fugitive PM10	Exhaust PM10	PM10 Total	Fugitive PM2.5	Exhaust PM2.5	PM2.5 Total	Bio- CO2	NBio- CO2	Total CO2	CH4	N2O	CO2e
Hauling	4.3100e-003	0.1838	0.0601	4.7000e-004	0.0599	5.3000e-004	0.0604	0.0150	5.0000e-004	0.0155	0.0000	49.9394	49.9394	9.1600e-003	0.0000	50.1684
Vendor	1.3000e-004	5.0400e-003	1.5400e-003	1.0000e-005	2.9000e-004	1.0000e-005	3.0000e-004	8.0000e-005	1.0000e-005	9.0000e-005	0.0000	1.2025	1.2025	1.6000e-004	0.0000	1.2065
Worker	9.4000e-004	6.0000e-004	6.8800e-003	3.0000e-005	2.6100e-003	2.0000e-005	2.6300e-003	6.9000e-004	2.0000e-005	7.1000e-004	0.0000	2.3898	2.3898	5.0000e-005	0.0000	2.3910
Total	5.3800e-003	0.1894	0.0685	5.1000e-004	0.0628	5.6000e-004	0.0634	0.0158	5.3000e-004	0.0163	0.0000	53.5316	53.5316	9.3700e-003	0.0000	53.7658

Mitigated Construction On-Site

Category	tons/yr										MT/yr					
	ROG	NOx	CO	SO2	Fugitive PM10	Exhaust PM10	PM10 Total	Fugitive PM2.5	Exhaust PM2.5	PM2.5 Total	Bio- CO2	NBio- CO2	Total CO2	CH4	N2O	CO2e
Fugitive Dust					5.1900e-003	0.0000	5.1900e-003	7.7000e-004	0.0000	7.7000e-004	0.0000	0.0000	0.0000	0.0000	0.0000	0.0000
Off-Road	2.5200e-003	0.0161	0.1358	2.3000e-004	3.2000e-004	3.2000e-004	3.2000e-004	3.2000e-004	3.2000e-004	3.2000e-004	0.0000	17.2814	17.2814	5.2000e-003	0.0000	17.4113
Total	2.5200e-003	0.0161	0.1358	2.3000e-004	5.1900e-003	3.2000e-004	5.5100e-003	7.7000e-004	3.2000e-004	1.0900e-003	0.0000	17.2814	17.2814	5.2000e-003	0.0000	17.4113

BCTD DB129.1 and DB129.2 - San Francisco County, Annual

3.3 Architectural Coating - 2020

Mitigated Construction Off-Site

Category	tons/yr										MT/yr						
	ROG	NOx	CO	SO2	Fugitive PM10	Exhaust PM10	PM10 Total	Fugitive PM2.5	Exhaust PM2.5	PM2.5 Total	Bio- CO2	NBio- CO2	Total CO2	CH4	N2O	CO2e	
Hauling	0.0000	0.0000	0.0000	0.0000	0.0000	0.0000	0.0000	0.0000	0.0000	0.0000	0.0000	0.0000	0.0000	0.0000	0.0000	0.0000	0.0000
Vendor	0.0000	0.0000	0.0000	0.0000	0.0000	0.0000	0.0000	0.0000	0.0000	0.0000	0.0000	0.0000	0.0000	0.0000	0.0000	0.0000	0.0000
Worker	0.0000	0.0000	0.0000	0.0000	0.0000	0.0000	0.0000	0.0000	0.0000	0.0000	0.0000	0.0000	0.0000	0.0000	0.0000	0.0000	0.0000
Total	0.0000	0.0000	0.0000	0.0000	0.0000	0.0000	0.0000	0.0000	0.0000	0.0000	0.0000	0.0000	0.0000	0.0000	0.0000	0.0000	0.0000

4.0 Operational Detail - Mobile

4.1 Mitigation Measures Mobile

BCTD DB129.1 and DB129.2 - San Francisco County, Annual

Category	tons/yr													MT/yr			
	ROG	NOx	CO	SO2	Fugitive PM10	Exhaust PM10	PM10 Total	Fugitive PM2.5	Exhaust PM2.5	PM2.5 Total	Bio- CO2	NBio- CO2	Total CO2	CH4	N2O	CO2e	
Mitigated	0.0000	0.0000	0.0000	0.0000	0.0000	0.0000	0.0000	0.0000	0.0000	0.0000	0.0000	0.0000	0.0000	0.0000	0.0000	0.0000	
Unmitigated	0.0000	0.0000	0.0000	0.0000	0.0000	0.0000	0.0000	0.0000	0.0000	0.0000	0.0000	0.0000	0.0000	0.0000	0.0000	0.0000	

4.2 Trip Summary Information

Land Use	Average Daily Trip Rate			Unmitigated		Mitigated	
	Weekday	Saturday	Sunday	Annual VMT	Annual VMT	Annual VMT	Annual VMT
User Defined Industrial	0.00	0.00	0.00				
Total	0.00	0.00	0.00				

4.3 Trip Type Information

Land Use	Miles						Trip %			Trip Purpose %		
	H-W or C-C	H-S or C-C	H-O or C-NW	H-W or C-W	H-S or C-C	H-O or C-NW	Primary	Diverted	Pass-by	Primary	Diverted	Pass-by
User Defined Industrial	9.50	7.30	7.30	0.00	0.00	0.00	0	0	0	0	0	0

4.4 Fleet Mix

Land Use	LDA	LDT1	LDT2	MDV	LHD1	LHD2	MHD	HHD	OBUS	UBUS	MCY	SBUS	MH
User Defined Industrial	0.606408	0.040118	0.191445	0.088323	0.014900	0.004926	0.028280	0.008891	0.004289	0.004272	0.006741	0.000931	0.000477

5.0 Energy Detail

Historical Energy Use: N

BCTD DB129.1 and DB129.2 - San Francisco County, Annual

5.3 Energy by Land Use - Electricity

Mitigated

Land Use	Electricity Use kWh/yr	Total CO2	CH4	N2O	CO2e
User Defined Industrial	0	0.0000	0.0000	0.0000	0.0000
Total		0.0000	0.0000	0.0000	0.0000

6.0 Area Detail

6.1 Mitigation Measures Area

Category	tons/yr																
	ROG	NOx	CO	SO2	Fugitive PM10	Exhaust PM10	PM10 Total	Fugitive PM2.5	Exhaust PM2.5	PM2.5 Total	Bio- CO2	NBio- CO2	Total CO2	CH4	N2O	CO2e	
Mitigated	0.0000	0.0000	1.0000e-005	0.0000	0.0000	0.0000	0.0000	0.0000	0.0000	0.0000	0.0000	2.0000e-005	2.0000e-005	0.0000	0.0000	0.0000	2.0000e-005
Unmitigated	0.0000	0.0000	1.0000e-005	0.0000	0.0000	0.0000	0.0000	0.0000	0.0000	0.0000	0.0000	2.0000e-005	2.0000e-005	0.0000	0.0000	0.0000	2.0000e-005

BCTD DB129.1 and DB129.2 - San Francisco County, Annual

6.2 Area by SubCategory

Unmitigated

SubCategory	tons/yr										MT/yr					
	ROG	NOx	CO	SO2	Fugitive PM10	Exhaust PM10	PM10 Total	Fugitive PM2.5	Exhaust PM2.5	PM2.5 Total	Bio- CO2	NBio- CO2	Total CO2	CH4	N2O	CO2e
Architectural Coating	0.0000					0.0000	0.0000		0.0000	0.0000	0.0000	0.0000	0.0000	0.0000	0.0000	0.0000
Consumer Products	0.0000					0.0000	0.0000		0.0000	0.0000	0.0000	0.0000	0.0000	0.0000	0.0000	0.0000
Landscaping	0.0000	0.0000	1.0000e-005	0.0000		0.0000	0.0000		0.0000	0.0000	0.0000	2.0000e-005	2.0000e-005	0.0000	0.0000	2.0000e-005
Total	0.0000	0.0000	1.0000e-005	0.0000		0.0000	0.0000		0.0000	0.0000	0.0000	2.0000e-005	2.0000e-005	0.0000	0.0000	2.0000e-005

Mitigated

SubCategory	tons/yr										MT/yr					
	ROG	NOx	CO	SO2	Fugitive PM10	Exhaust PM10	PM10 Total	Fugitive PM2.5	Exhaust PM2.5	PM2.5 Total	Bio- CO2	NBio- CO2	Total CO2	CH4	N2O	CO2e
Architectural Coating	0.0000					0.0000	0.0000		0.0000	0.0000	0.0000	0.0000	0.0000	0.0000	0.0000	0.0000
Consumer Products	0.0000					0.0000	0.0000		0.0000	0.0000	0.0000	0.0000	0.0000	0.0000	0.0000	0.0000
Landscaping	0.0000	0.0000	1.0000e-005	0.0000		0.0000	0.0000		0.0000	0.0000	0.0000	2.0000e-005	2.0000e-005	0.0000	0.0000	2.0000e-005
Total	0.0000	0.0000	1.0000e-005	0.0000		0.0000	0.0000		0.0000	0.0000	0.0000	2.0000e-005	2.0000e-005	0.0000	0.0000	2.0000e-005

7.0 Water Detail

7.1 Mitigation Measures Water

	Total CO2	CH4	N2O	CO2e
Category	MT/yr			
Mitigated	0.0000	0.0000	0.0000	0.0000
Unmitigated	0.0000	0.0000	0.0000	0.0000

7.2 Water by Land Use

Unmitigated

	Indoor/Outdoor Use	Total CO2	CH4	N2O	CO2e
Land Use	Mgal				
User Defined Industrial	0 / 0	0.0000	0.0000	0.0000	0.0000
Total		0.0000	0.0000	0.0000	0.0000

BCTD DB129.1 and DB129.2 - San Francisco County, Annual

7.2 Water by Land Use

Mitigated

Land Use	Indoor/Outdoor Use	Total CO2	CH4	N2O	CO2e
	Mgal	MT/yr			
User Defined Industrial	0 / 0	0.0000	0.0000	0.0000	0.0000
Total		0.0000	0.0000	0.0000	0.0000

8.0 Waste Detail

8.1 Mitigation Measures Waste

Category/Year

Category/Year	Total CO2	CH4	N2O	CO2e
	MT/yr			
Mitigated	0.0000	0.0000	0.0000	0.0000
Unmitigated	0.0000	0.0000	0.0000	0.0000

BCTD DB129.1 and DB129.2 - San Francisco County, Annual

8.2 Waste by Land Use

Unmitigated

Land Use	Waste Disposed tons	Total CO2				CO2e
		CH4	N2O	MT/yr		
User Defined Industrial	0	0.0000	0.0000	0.0000	0.0000	0.0000
Total		0.0000	0.0000	0.0000	0.0000	0.0000

Mitigated

Land Use	Waste Disposed tons	Total CO2				CO2e
		CH4	N2O	MT/yr		
User Defined Industrial	0	0.0000	0.0000	0.0000	0.0000	0.0000
Total		0.0000	0.0000	0.0000	0.0000	0.0000

9.0 Operational Offroad

Equipment Type	Number	Hours/Day	Days/Year	Horse Power	Load Factor	Fuel Type
----------------	--------	-----------	-----------	-------------	-------------	-----------

BCTD DB129.1 and DB129.2 - San Francisco County, Annual

10.0 Stationary Equipment

Fire Pumps and Emergency Generators

Equipment Type	Number	Hours/Day	Hours/Year	Horse Power	Load Factor	Fuel Type
----------------	--------	-----------	------------	-------------	-------------	-----------

Boilers

Equipment Type	Number	Heat Input/Day	Heat Input/Year	Boiler Rating	Fuel Type
----------------	--------	----------------	-----------------	---------------	-----------

User Defined Equipment

Equipment Type	Number
----------------	--------

11.0 Vegetation

Islais Creek CalEEMod Runs

Islais Creek Ground Improvements - San Francisco County, Annual

**Islais Creek Ground Improvements
San Francisco County, Annual**

1.0 Project Characteristics

1.1 Land Usage

Land Uses	Size	Metric	Lot Acreage	Floor Surface Area	Population
User Defined Industrial	1.00	User Defined Unit	1.27	0.00	0

1.2 Other Project Characteristics

Urbanization	Urban	Wind Speed (m/s)	4.6	Precipitation Freq (Days)	64
Climate Zone	5			Operational Year	2021

Utility Company Pacific Gas & Electric Company

CO2 Intensity (lb/MW/hr)	641.35	CH4 Intensity (lb/MW/hr)	0.029	N2O Intensity (lb/MW/hr)	0.006
---------------------------------	--------	---------------------------------	-------	---------------------------------	-------

1.3 User Entered Comments & Non-Default Data

Project Characteristics -

Land Use - Construction only run for ground improvements. Project acreage based on trenching limits.

Construction Phase - Project specific construction schedule.

Off-road Equipment - Modeled under one phase.

Off-road Equipment - Modeled under one phase.

Off-road Equipment - Project specific construction equipment.

Trips and VMT - Based on 9 workers per day and approximately one pick-up truck per day.

Grading - Default acres graded. Material import and export quantities included in DB129.1 and DB129.2 runs.

Construction Off-road Equipment Mitigation - Assumes fugitive dust control and use of Tier 2 B20 fuel. Generator assumed to be electric.

Islais Creek Ground Improvements - San Francisco County, Annual

Table Name	Column Name	Default Value	New Value
tblConstEquipMitigation	FuelType	Diesel	Bio-diesel
tblConstEquipMitigation	FuelType	Diesel	Bio-diesel
tblConstEquipMitigation	FuelType	Diesel	Bio-diesel
tblConstEquipMitigation	FuelType	Diesel	Bio-diesel
tblConstEquipMitigation	FuelType	Diesel	Electrical
tblConstEquipMitigation	FuelType	Diesel	Bio-diesel
tblConstEquipMitigation	FuelType	Diesel	Bio-diesel
tblConstEquipMitigation	FuelType	Diesel	Bio-diesel
tblConstEquipMitigation	NumberOfEquipmentMitigated	0.00	1.00
tblConstEquipMitigation	NumberOfEquipmentMitigated	0.00	1.00
tblConstEquipMitigation	NumberOfEquipmentMitigated	0.00	1.00
tblConstEquipMitigation	NumberOfEquipmentMitigated	0.00	1.00
tblConstEquipMitigation	NumberOfEquipmentMitigated	0.00	1.00
tblConstEquipMitigation	NumberOfEquipmentMitigated	0.00	1.00
tblConstEquipMitigation	NumberOfEquipmentMitigated	0.00	1.00
tblConstEquipMitigation	NumberOfEquipmentMitigated	0.00	1.00
tblConstEquipMitigation	Tier	No Change	Tier 2
tblConstEquipMitigation	Tier	No Change	Tier 2
tblConstEquipMitigation	Tier	No Change	Tier 2
tblConstEquipMitigation	Tier	No Change	Tier 2
tblConstEquipMitigation	Tier	No Change	Tier 2
tblConstEquipMitigation	Tier	No Change	Tier 2
tblConstEquipMitigation	Tier	No Change	Tier 2
tblConstructionPhase	NumDays	10.00	0.00
tblConstructionPhase	NumDays	2.00	0.00
tblGrading	AcresOfGrading	0.00	1.00

Islais Creek Ground Improvements - San Francisco County, Annual

tblLandUse	LotAcreage	0.00	1.27
tblOffRoadEquipment	OffRoadEquipmentUnitAmount	1.00	0.00
tblOffRoadEquipment	OffRoadEquipmentUnitAmount	1.00	0.00
tblOffRoadEquipment	OffRoadEquipmentUnitAmount	1.00	0.00
tblOffRoadEquipment	OffRoadEquipmentUnitAmount	1.00	0.00
tblOffRoadEquipment	UsageHours	6.00	0.00
tblOffRoadEquipment	UsageHours	8.00	0.00
tblOffRoadEquipment	UsageHours	7.00	0.00
tblOffRoadEquipment	UsageHours	8.00	0.00
tblTripsAndVMT	VendorTripNumber	0.00	2.00
tblTripsAndVMT	WorkerTripNumber	20.00	18.00

2.0 Emissions Summary

Islais Creek Ground Improvements - San Francisco County, Annual

2.1 Overall Construction
Unmitigated Construction

Year	tons/yr											MT/yr				
	ROG	NOx	CO	SO2	Fugitive PM10	Exhaust PM10	PM10 Total	Fugitive PM2.5	Exhaust PM2.5	PM2.5 Total	Bio- CO2	NBio- CO2	Total CO2	CH4	N2O	CO2e
2020	0.0501	0.5144	0.3588	9.5000e-004	5.1300e-003	0.0222	0.0273	1.3700e-003	0.0209	0.0223	0.0000	83.6487	83.6487	0.0214	0.0000	84.1845
2021	0.0152	0.1519	0.1167	3.2000e-004	1.7100e-003	6.4300e-003	8.1400e-003	4.6000e-004	6.0400e-003	6.5000e-003	0.0000	27.8449	27.8449	7.1100e-003	0.0000	28.0227
Maximum	0.0501	0.5144	0.3588	9.5000e-004	5.1300e-003	0.0222	0.0273	1.3700e-003	0.0209	0.0223	0.0000	83.6487	83.6487	0.0214	0.0000	84.1845

Mitigated Construction

Year	tons/yr											MT/yr				
	ROG	NOx	CO	SO2	Fugitive PM10	Exhaust PM10	PM10 Total	Fugitive PM2.5	Exhaust PM2.5	PM2.5 Total	Bio- CO2	NBio- CO2	Total CO2	CH4	N2O	CO2e
2020	0.0194	0.6799	0.4081	9.5000e-004	5.1300e-003	0.0151	0.0202	1.3700e-003	0.0151	0.0165	13.6070	60.7157	74.3227	0.0209	0.0000	74.8454
2021	6.4200e-003	0.2264	0.1357	3.2000e-004	1.7100e-003	5.0200e-003	6.7300e-003	4.6000e-004	5.0200e-003	5.4800e-003	4.5402	20.1960	24.7362	6.9600e-003	0.0000	24.9101
Maximum	0.0194	0.6799	0.4081	9.5000e-004	5.1300e-003	0.0151	0.0202	1.3700e-003	0.0151	0.0165	13.6070	60.7157	74.3227	0.0209	0.0000	74.8454

ROG	NOx	CO	SO2	Fugitive PM10	Exhaust PM10	PM10 Total	Fugitive PM2.5	Exhaust PM2.5	PM2.5 Total	Bio- CO2	NBio- CO2	Total CO2	CH4	N2O	CO2e
Percent Reduction	60.44	-36.04	0.00	0.00	29.73	24.00	0.00	25.30	23.69	0.00	27.43	11.15	2.35	0.00	11.10

Islais Creek Ground Improvements - San Francisco County, Annual

Quarter	Start Date	End Date	Maximum Unmitigated ROG + NOX (tons/quarter)	Maximum Mitigated ROG + NOX (tons/quarter)
1	10-1-2020	12-31-2020	0.5623	0.6966
2	1-1-2021	3-31-2021	0.1737	0.2420
		Highest	0.5623	0.6966

2.2 Overall Operational

Unmitigated Operational

Category	tons/yr										MT/yr						
	ROG	NOx	CO	SO2	Fugitive PM10	Exhaust PM10	PM10 Total	Fugitive PM2.5	Exhaust PM2.5	PM2.5 Total	Bio- CO2	NBio- CO2	Total CO2	CH4	N2O	CO2e	
Area	0.0000	0.0000	1.0000e-005	0.0000	0.0000	0.0000	0.0000	0.0000	0.0000	0.0000	0.0000	2.0000e-005	2.0000e-005	0.0000	0.0000	0.0000	2.0000e-005
Energy	0.0000	0.0000	0.0000	0.0000	0.0000	0.0000	0.0000	0.0000	0.0000	0.0000	0.0000	0.0000	0.0000	0.0000	0.0000	0.0000	0.0000
Mobile	0.0000	0.0000	0.0000	0.0000	0.0000	0.0000	0.0000	0.0000	0.0000	0.0000	0.0000	0.0000	0.0000	0.0000	0.0000	0.0000	0.0000
Waste					0.0000	0.0000	0.0000	0.0000	0.0000	0.0000	0.0000	0.0000	0.0000	0.0000	0.0000	0.0000	0.0000
Water					0.0000	0.0000	0.0000	0.0000	0.0000	0.0000	0.0000	0.0000	0.0000	0.0000	0.0000	0.0000	0.0000
Total	0.0000	0.0000	1.0000e-005	0.0000	0.0000	0.0000	0.0000	0.0000	0.0000	0.0000	0.0000	2.0000e-005	2.0000e-005	0.0000	0.0000	0.0000	2.0000e-005

Islais Creek Ground Improvements - San Francisco County, Annual

2.2 Overall Operational

Mitigated Operational

Category	tons/yr											MT/yr					
	ROG	NOx	CO	SO2	Fugitive PM10	Exhaust PM10	PM10 Total	Fugitive PM2.5	Exhaust PM2.5	PM2.5 Total	Bio- CO2	NBio- CO2	Total CO2	CH4	N2O	CO2e	
Area	0.0000	0.0000	1.0000e-005	0.0000	0.0000	0.0000	0.0000	0.0000	0.0000	0.0000	0.0000	2.0000e-005	2.0000e-005	0.0000	0.0000	0.0000	2.0000e-005
Energy	0.0000	0.0000	0.0000	0.0000	0.0000	0.0000	0.0000	0.0000	0.0000	0.0000	0.0000	0.0000	0.0000	0.0000	0.0000	0.0000	0.0000
Mobile	0.0000	0.0000	0.0000	0.0000	0.0000	0.0000	0.0000	0.0000	0.0000	0.0000	0.0000	0.0000	0.0000	0.0000	0.0000	0.0000	0.0000
Waste	0.0000	0.0000	0.0000	0.0000	0.0000	0.0000	0.0000	0.0000	0.0000	0.0000	0.0000	0.0000	0.0000	0.0000	0.0000	0.0000	0.0000
Water	0.0000	0.0000	0.0000	0.0000	0.0000	0.0000	0.0000	0.0000	0.0000	0.0000	0.0000	0.0000	0.0000	0.0000	0.0000	0.0000	0.0000
Total	0.0000	0.0000	1.0000e-005	0.0000	0.0000	0.0000	0.0000	0.0000	0.0000	0.0000	0.0000	2.0000e-005	2.0000e-005	0.0000	0.0000	0.0000	2.0000e-005

Percent Reduction	tons/yr											MT/yr				
	ROG	NOx	CO	SO2	Fugitive PM10	Exhaust PM10	PM10 Total	Fugitive PM2.5	Exhaust PM2.5	PM2.5 Total	Bio- CO2	NBio- CO2	Total CO2	CH4	N2O	CO2e
0.00	0.00	0.00	0.00	0.00	0.00	0.00	0.00	0.00	0.00	0.00	0.00	0.00	0.00	0.00	0.00	0.00

3.0 Construction Detail

Construction Phase

Phase Number	Phase Name	Phase Type	Start Date	End Date	Num Days Week	Num Days	Phase Description
1	Trenching	Trenching	10/1/2020	2/1/2021	5	88	
2	Site Preparation	Site Preparation	10/29/2020	10/28/2020	5	0	
3	Architectural Coating	Architectural Coating	8/27/2021	8/26/2021	5	0	

Islais Creek Ground Improvements - San Francisco County, Annual

Acres of Grading (Site Preparation Phase): 1

Acres of Grading (Grading Phase): 0

Acres of Paving: 0

Residential Indoor: 0; Residential Outdoor: 0; Non-Residential Indoor: 0; Non-Residential Outdoor: 0; Striped Parking Area: 0 (Architectural Coating – sqft)

OffRoad Equipment

Phase Name	Offroad Equipment Type	Amount	Usage Hours	Horse Power	Load Factor
Site Preparation	Graders	0	0.00	187	0.41
Site Preparation	Rubber Tired Dozers	0	0.00	247	0.40
Site Preparation	Tractors/Loaders/Backhoes	0	0.00	97	0.37
Architectural Coating	Air Compressors	0	0.00	78	0.48
Trenching	Air Compressors	1	4.00	78	0.48
Trenching	Bore/Drill Rigs	1	8.00	221	0.50
Trenching	Cranes	1	8.00	231	0.29
Trenching	Excavators	1	1.00	158	0.38
Trenching	Generator Sets	1	4.00	84	0.74
Trenching	Off-Highway Trucks	1	2.00	402	0.38
Trenching	Plate Compactors	1	2.00	8	0.43
Trenching	Tractors/Loaders/Backhoes	1	6.00	97	0.37

Trips and VMT

Islais Creek Ground Improvements - San Francisco County, Annual

Phase Name	Offroad Equipment Count	Worker Trip Number	Vendor Trip Number	Hauling Trip Number	Worker Trip Length	Vendor Trip Length	Hauling Trip Length	Worker Vehicle Class	Vendor Vehicle Class	Hauling Vehicle Class
Site Preparation	0	0.00	0.00	0.00	10.80	7.30	20.00	LD_Mix	HDT_Mix	HHDT
Architectural Coating	0	0.00	0.00	0.00	10.80	7.30	20.00	LD_Mix	HDT_Mix	HHDT
Trenching	8	18.00	2.00	0.00	10.80	7.30	20.00	LD_Mix	HDT_Mix	HHDT

3.1 Mitigation Measures Construction

- Use Alternative Fuel for Construction Equipment
- Use Cleaner Engines for Construction Equipment
- Water Exposed Area

3.2 Trenching - 2020

Unmitigated Construction On-Site

Category	ROG	NOx	CO	SO2	Fugitive PM10	Exhaust PM10	PM10 Total	Fugitive PM2.5	Exhaust PM2.5	PM2.5 Total	Bio- CO2	NBio- CO2	Total CO2	CH4	N2O	CO2e
	tons/yr															
Off-Road	0.0480	0.5049	0.3430	8.9000e-004	0.0221	0.0221	0.0221	0.0208	0.0208	0.0208	0.0000	77.3608	77.3608	0.0211	0.0000	77.8881
Total	0.0480	0.5049	0.3430	8.9000e-004	0.0221	0.0221	0.0221	0.0208	0.0208	0.0208	0.0000	77.3608	77.3608	0.0211	0.0000	77.8881

Islais Creek Ground Improvements - San Francisco County, Annual

3.2 Trenching - 2020
Unmitigated Construction Off-Site

Category	tons/yr										MT/yr					
	ROG	NOx	CO	SO2	Fugitive PM10	Exhaust PM10	PM10 Total	Fugitive PM2.5	Exhaust PM2.5	PM2.5 Total	Bio- CO2	NBio- CO2	Total CO2	CH4	N2O	CO2e
Hauling	0.0000	0.0000	0.0000	0.0000	0.0000	0.0000	0.0000	0.0000	0.0000	0.0000	0.0000	0.0000	0.0000	0.0000	0.0000	0.0000
Vendor	2.4000e-004	8.2600e-003	2.4400e-003	2.0000e-005	4.3000e-004	4.0000e-005	4.7000e-004	1.2000e-004	3.0000e-005	1.6000e-004	0.0000	1.8270	1.8270	2.4000e-004	0.0000	1.8330
Worker	1.8100e-003	1.2000e-003	0.0134	5.0000e-005	4.6900e-003	4.0000e-005	4.7300e-003	1.2500e-003	3.0000e-005	1.2800e-003	0.0000	4.4609	4.4609	1.0000e-004	0.0000	4.4634
Total	2.0500e-003	9.4600e-003	0.0158	7.0000e-005	5.1200e-003	8.0000e-005	5.2000e-003	1.3700e-003	6.0000e-005	1.4400e-003	0.0000	6.2879	6.2879	3.4000e-004	0.0000	6.2964

Mitigated Construction On-Site

Category	tons/yr										MT/yr					
	ROG	NOx	CO	SO2	Fugitive PM10	Exhaust PM10	PM10 Total	Fugitive PM2.5	Exhaust PM2.5	PM2.5 Total	Bio- CO2	NBio- CO2	Total CO2	CH4	N2O	CO2e
Off-Road	0.0174	0.6705	0.3923	8.9000e-004		0.0150	0.0150		0.0150	0.0150	13.6070	54.4279	68.0348	0.0206	0.0000	68.5490
Total	0.0174	0.6705	0.3923	8.9000e-004		0.0150	0.0150		0.0150	0.0150	13.6070	54.4279	68.0348	0.0206	0.0000	68.5490

Islais Creek Ground Improvements - San Francisco County, Annual

3.2 Trenching - 2020

Mitigated Construction Off-Site

Category	tons/yr										MT/yr					
	ROG	NOx	CO	SO2	Fugitive PM10	Exhaust PM10	PM10 Total	Fugitive PM2.5	Exhaust PM2.5	PM2.5 Total	Bio- CO2	NBio- CO2	Total CO2	CH4	N2O	CO2e
Hauling	0.0000	0.0000	0.0000	0.0000	0.0000	0.0000	0.0000	0.0000	0.0000	0.0000	0.0000	0.0000	0.0000	0.0000	0.0000	0.0000
Vendor	2.4000e-004	8.2600e-003	2.4400e-003	2.0000e-005	4.3000e-004	4.0000e-005	4.7000e-004	1.2000e-004	3.0000e-005	1.6000e-004	0.0000	1.8270	1.8270	2.4000e-004	0.0000	1.8330
Worker	1.8100e-003	1.2000e-003	0.0134	5.0000e-005	4.6900e-003	4.0000e-005	4.7300e-003	1.2500e-003	3.0000e-005	1.2800e-003	0.0000	4.4609	4.4609	1.0000e-004	0.0000	4.4634
Total	2.0500e-003	9.4600e-003	0.0158	7.0000e-005	5.1200e-003	8.0000e-005	5.2000e-003	1.3700e-003	6.0000e-005	1.4400e-003	0.0000	6.2879	6.2879	3.4000e-004	0.0000	6.2964

3.2 Trenching - 2021

Unmitigated Construction On-Site

Category	tons/yr										MT/yr					
	ROG	NOx	CO	SO2	Fugitive PM10	Exhaust PM10	PM10 Total	Fugitive PM2.5	Exhaust PM2.5	PM2.5 Total	Bio- CO2	NBio- CO2	Total CO2	CH4	N2O	CO2e
Off-Road	0.0146	0.1490	0.1119	3.0000e-004	6.4100e-003	6.4100e-003	6.4100e-003	6.0300e-003	6.0300e-003	6.0300e-003	0.0000	25.8098	25.8098	7.0000e-003	0.0000	25.9849
Total	0.0146	0.1490	0.1119	3.0000e-004	6.4100e-003	6.4100e-003	6.4100e-003	6.0300e-003	6.0300e-003	6.0300e-003	0.0000	25.8098	25.8098	7.0000e-003	0.0000	25.9849

Islais Creek Ground Improvements - San Francisco County, Annual

3.2 Trenching - 2021
Unmitigated Construction Off-Site

Category	tons/yr										MT/yr					
	ROG	NOx	CO	SO2	Fugitive PM10	Exhaust PM10	PM10 Total	Fugitive PM2.5	Exhaust PM2.5	PM2.5 Total	Bio- CO2	NBio- CO2	Total CO2	CH4	N2O	CO2e
Hauling	0.0000	0.0000	0.0000	0.0000	0.0000	0.0000	0.0000	0.0000	0.0000	0.0000	0.0000	0.0000	0.0000	0.0000	0.0000	0.0000
Vendor	7.0000e-005	2.5200e-003	7.7000e-004	1.0000e-005	1.4000e-004	1.0000e-005	1.5000e-004	1.0000e-005	1.0000e-005	5.0000e-005	0.0000	0.6012	0.6012	8.0000e-005	0.0000	0.6032
Worker	5.6000e-004	3.6000e-004	4.1200e-003	2.0000e-005	1.5600e-003	1.0000e-005	1.5800e-003	1.0000e-005	1.0000e-005	4.3000e-004	0.0000	1.4339	1.4339	3.0000e-005	0.0000	1.4346
Total	6.3000e-004	2.8800e-003	4.8900e-003	3.0000e-005	1.7000e-003	2.0000e-005	1.7300e-003	4.6000e-004	2.0000e-005	4.8000e-004	0.0000	2.0351	2.0351	1.1000e-004	0.0000	2.0378

Mitigated Construction On-Site

Category	tons/yr										MT/yr					
	ROG	NOx	CO	SO2	Fugitive PM10	Exhaust PM10	PM10 Total	Fugitive PM2.5	Exhaust PM2.5	PM2.5 Total	Bio- CO2	NBio- CO2	Total CO2	CH4	N2O	CO2e
Off-Road	5.7900e-003	0.2235	0.1308	3.0000e-004		5.0100e-003	5.0100e-003	5.0100e-003	5.0100e-003	5.0100e-003	4.5402	18.1609	22.7011	6.8500e-003	0.0000	22.8723
Total	5.7900e-003	0.2235	0.1308	3.0000e-004		5.0100e-003	5.0100e-003	5.0100e-003	5.0100e-003	5.0100e-003	4.5402	18.1609	22.7011	6.8500e-003	0.0000	22.8723

Islais Creek Ground Improvements - San Francisco County, Annual

3.4 Architectural Coating - 2021

Mitigated Construction Off-Site

Category	tons/yr										MT/yr						
	ROG	NOx	CO	SO2	Fugitive PM10	Exhaust PM10	PM10 Total	Fugitive PM2.5	Exhaust PM2.5	PM2.5 Total	Bio- CO2	NBio- CO2	Total CO2	CH4	N2O	CO2e	
Hauling	0.0000	0.0000	0.0000	0.0000	0.0000	0.0000	0.0000	0.0000	0.0000	0.0000	0.0000	0.0000	0.0000	0.0000	0.0000	0.0000	0.0000
Vendor	0.0000	0.0000	0.0000	0.0000	0.0000	0.0000	0.0000	0.0000	0.0000	0.0000	0.0000	0.0000	0.0000	0.0000	0.0000	0.0000	0.0000
Worker	0.0000	0.0000	0.0000	0.0000	0.0000	0.0000	0.0000	0.0000	0.0000	0.0000	0.0000	0.0000	0.0000	0.0000	0.0000	0.0000	0.0000
Total	0.0000	0.0000	0.0000	0.0000	0.0000	0.0000	0.0000	0.0000	0.0000	0.0000	0.0000	0.0000	0.0000	0.0000	0.0000	0.0000	0.0000

4.0 Operational Detail - Mobile

4.1 Mitigation Measures Mobile

Islais Creek Ground Improvements - San Francisco County, Annual

Category	tons/yr													MT/yr			
	ROG	NOx	CO	SO2	Fugitive PM10	Exhaust PM10	PM10 Total	Fugitive PM2.5	Exhaust PM2.5	PM2.5 Total	Bio- CO2	NBio- CO2	Total CO2	CH4	N2O	CO2e	
Mitigated	0.0000	0.0000	0.0000	0.0000	0.0000	0.0000	0.0000	0.0000	0.0000	0.0000	0.0000	0.0000	0.0000	0.0000	0.0000	0.0000	
Unmitigated	0.0000	0.0000	0.0000	0.0000	0.0000	0.0000	0.0000	0.0000	0.0000	0.0000	0.0000	0.0000	0.0000	0.0000	0.0000	0.0000	

4.2 Trip Summary Information

Land Use	Average Daily Trip Rate			Unmitigated		Mitigated	
	Weekday	Saturday	Sunday	Annual VMT	Annual VMT	Annual VMT	Annual VMT
User Defined Industrial	0.00	0.00	0.00				
Total	0.00	0.00	0.00				

4.3 Trip Type Information

Land Use	Miles						Trip %			Trip Purpose %		
	H-W or C-C	H-S or C-C	H-O or C-NW	H-W or C-W	H-S or C-C	H-O or C-NW	Primary	Diverted	Pass-by	Primary	Diverted	Pass-by
User Defined Industrial	9.50	7.30	7.30	0.00	0.00	0.00	0	0	0	0	0	0

4.4 Fleet Mix

Land Use	LDA	LDT1	LDT2	MDV	LHD1	LHD2	MHD	HHD	OBUS	UBUS	MCY	SBUS	MH
User Defined Industrial	0.606408	0.040118	0.191445	0.088323	0.014900	0.004926	0.028280	0.008891	0.004289	0.004272	0.006741	0.000931	0.000477

5.0 Energy Detail

Historical Energy Use: N

Islais Creek Ground Improvements - San Francisco County, Annual

5.3 Energy by Land Use - Electricity

Mitigated

Land Use	Electricity Use kWh/yr	Total CO2	CH4	N2O	CO2e
User Defined Industrial	0	0.0000	0.0000	0.0000	0.0000
Total		0.0000	0.0000	0.0000	0.0000

6.0 Area Detail

6.1 Mitigation Measures Area

Category	tons/yr											MT/yr					
	ROG	NOx	CO	SO2	Fugitive PM10	Exhaust PM10	PM10 Total	Fugitive PM2.5	Exhaust PM2.5	PM2.5 Total	Bio- CO2	NBio- CO2	Total CO2	CH4	N2O	CO2e	
Mitigated	0.0000	0.0000	1.0000e-005	0.0000	0.0000	0.0000	0.0000	0.0000	0.0000	0.0000	0.0000	2.0000e-005	2.0000e-005	0.0000	0.0000	0.0000	2.0000e-005
Unmitigated	0.0000	0.0000	1.0000e-005	0.0000	0.0000	0.0000	0.0000	0.0000	0.0000	0.0000	0.0000	2.0000e-005	2.0000e-005	0.0000	0.0000	0.0000	2.0000e-005

Islais Creek Ground Improvements - San Francisco County, Annual

6.2 Area by SubCategory

Unmitigated

SubCategory	tons/yr										MT/yr						
	ROG	NOx	CO	SO2	Fugitive PM10	Exhaust PM10	PM10 Total	Fugitive PM2.5	Exhaust PM2.5	PM2.5 Total	Bio- CO2	NBio- CO2	Total CO2	CH4	N2O	CO2e	
Architectural Coating	0.0000					0.0000	0.0000	0.0000	0.0000	0.0000	0.0000	0.0000	0.0000	0.0000	0.0000	0.0000	0.0000
Consumer Products	0.0000					0.0000	0.0000	0.0000	0.0000	0.0000	0.0000	0.0000	0.0000	0.0000	0.0000	0.0000	0.0000
Landscaping	0.0000	0.0000	1.0000e-005	0.0000		0.0000	0.0000	0.0000	0.0000	0.0000	0.0000	2.0000e-005	2.0000e-005	0.0000	0.0000	0.0000	2.0000e-005
Total	0.0000	0.0000	1.0000e-005	0.0000		0.0000	0.0000	0.0000	0.0000	0.0000	0.0000	2.0000e-005	2.0000e-005	0.0000	0.0000	0.0000	2.0000e-005

Mitigated

SubCategory	tons/yr										MT/yr						
	ROG	NOx	CO	SO2	Fugitive PM10	Exhaust PM10	PM10 Total	Fugitive PM2.5	Exhaust PM2.5	PM2.5 Total	Bio- CO2	NBio- CO2	Total CO2	CH4	N2O	CO2e	
Architectural Coating	0.0000					0.0000	0.0000	0.0000	0.0000	0.0000	0.0000	0.0000	0.0000	0.0000	0.0000	0.0000	0.0000
Consumer Products	0.0000					0.0000	0.0000	0.0000	0.0000	0.0000	0.0000	0.0000	0.0000	0.0000	0.0000	0.0000	0.0000
Landscaping	0.0000	0.0000	1.0000e-005	0.0000		0.0000	0.0000	0.0000	0.0000	0.0000	0.0000	2.0000e-005	2.0000e-005	0.0000	0.0000	0.0000	2.0000e-005
Total	0.0000	0.0000	1.0000e-005	0.0000		0.0000	0.0000	0.0000	0.0000	0.0000	0.0000	2.0000e-005	2.0000e-005	0.0000	0.0000	0.0000	2.0000e-005

7.0 Water Detail

7.1 Mitigation Measures Water

	Total CO2	CH4	N2O	CO2e
Category	MT/yr			
Mitigated	0.0000	0.0000	0.0000	0.0000
Unmitigated	0.0000	0.0000	0.0000	0.0000

**7.2 Water by Land Use
Unmitigated**

	Indoor/Outdoor Use	Total CO2	CH4	N2O	CO2e
Land Use	Mgal				
User Defined Industrial	0 / 0	0.0000	0.0000	0.0000	0.0000
Total		0.0000	0.0000	0.0000	0.0000

Islais Creek Ground Improvements - San Francisco County, Annual

7.2 Water by Land Use

Mitigated

Land Use	Indoor/Outdoor Use	Total CO2	CH4	N2O	CO2e
	Mgal	MT/yr			
User Defined Industrial	0 / 0	0.0000	0.0000	0.0000	0.0000
Total		0.0000	0.0000	0.0000	0.0000

8.0 Waste Detail

8.1 Mitigation Measures Waste

Category/Year

Category/Year	Total CO2	CH4	N2O	CO2e
	MT/yr			
Mitigated	0.0000	0.0000	0.0000	0.0000
Unmitigated	0.0000	0.0000	0.0000	0.0000

Islais Creek Ground Improvements - San Francisco County, Annual

8.2 Waste by Land Use

Unmitigated

Land Use	Waste Disposed tons	Total CO2				CO2e
		CH4	N2O	MT/yr		
User Defined Industrial	0	0.0000	0.0000	0.0000	0.0000	0.0000
Total		0.0000	0.0000	0.0000	0.0000	0.0000

Mitigated

Land Use	Waste Disposed tons	Total CO2				CO2e
		CH4	N2O	MT/yr		
User Defined Industrial	0	0.0000	0.0000	0.0000	0.0000	0.0000
Total		0.0000	0.0000	0.0000	0.0000	0.0000

9.0 Operational Offroad

Equipment Type	Number	Hours/Day	Days/Year	Horse Power	Load Factor	Fuel Type
----------------	--------	-----------	-----------	-------------	-------------	-----------

Islais Creek Ground Improvements - San Francisco County, Annual

10.0 Stationary Equipment

Fire Pumps and Emergency Generators

Equipment Type	Number	Hours/Day	Hours/Year	Horse Power	Load Factor	Fuel Type
----------------	--------	-----------	------------	-------------	-------------	-----------

Boilers

Equipment Type	Number	Heat Input/Day	Heat Input/Year	Boiler Rating	Fuel Type
----------------	--------	----------------	-----------------	---------------	-----------

User Defined Equipment

Equipment Type	Number
----------------	--------

11.0 Vegetation

Islais Creek Ground Improvements - San Francisco County, Annual

Islais Creek Ground Improvements
San Francisco County, Annual

1.0 Project Characteristics

1.1 Land Usage

Land Uses	Size	Metric	Lot Acreage	Floor Surface Area	Population
User Defined Industrial	1.00	User Defined Unit	1.27	0.00	0

1.2 Other Project Characteristics

Urbanization	Urban	Wind Speed (m/s)	4.6	Precipitation Freq (Days)	64
Climate Zone	5			Operational Year	2021

Utility Company Pacific Gas & Electric Company

CO2 Intensity (lb/MW/hr)	641.35	CH4 Intensity (lb/MW/hr)	0.029	N2O Intensity (lb/MW/hr)	0.006
---------------------------------	--------	---------------------------------	-------	---------------------------------	-------

1.3 User Entered Comments & Non-Default Data

Project Characteristics -

Land Use - Construction only run for ground improvements. Project acreage based on trenching limits.

Construction Phase - Project specific construction schedule.

Off-road Equipment - Modeled under one phase.

Off-road Equipment - Modeled under one phase.

Off-road Equipment - Project specific construction equipment.

Trips and VMT - Based on 9 workers per day and approximately one pick-up truck per day.

Grading - Default acres graded. Material import and export quantities included in DB129.1 and DB129.2 runs.

Construction Off-road Equipment Mitigation - Assumes fugitive dust control and use of Tier 2 engines with Lvl 3 DPF. Generator assumed to be electric.

Islais Creek Ground Improvements - San Francisco County, Annual

Table Name	Column Name	Default Value	New Value
tblConstEquipMitigation	DPF	No Change	Level 3
tblConstEquipMitigation	DPF	No Change	Level 3
tblConstEquipMitigation	DPF	No Change	Level 3
tblConstEquipMitigation	DPF	No Change	Level 3
tblConstEquipMitigation	DPF	No Change	Level 3
tblConstEquipMitigation	DPF	No Change	Level 3
tblConstEquipMitigation	DPF	No Change	Level 3
tblConstEquipMitigation	FuelType	Diesel	Electrical
tblConstEquipMitigation	NumberOfEquipmentMitigated	0.00	1.00
tblConstEquipMitigation	NumberOfEquipmentMitigated	0.00	1.00
tblConstEquipMitigation	NumberOfEquipmentMitigated	0.00	1.00
tblConstEquipMitigation	NumberOfEquipmentMitigated	0.00	1.00
tblConstEquipMitigation	NumberOfEquipmentMitigated	0.00	1.00
tblConstEquipMitigation	NumberOfEquipmentMitigated	0.00	1.00
tblConstEquipMitigation	NumberOfEquipmentMitigated	0.00	1.00
tblConstEquipMitigation	NumberOfEquipmentMitigated	0.00	1.00
tblConstEquipMitigation	Tier	No Change	Tier 2
tblConstEquipMitigation	Tier	No Change	Tier 2
tblConstEquipMitigation	Tier	No Change	Tier 2
tblConstEquipMitigation	Tier	No Change	Tier 2
tblConstEquipMitigation	Tier	No Change	Tier 2
tblConstEquipMitigation	Tier	No Change	Tier 2
tblConstEquipMitigation	Tier	No Change	Tier 2
tblConstructionPhase	NumDays	10.00	0.00
tblConstructionPhase	NumDays	2.00	0.00
tblGrading	AcresOfGrading	0.00	1.00

Islais Creek Ground Improvements - San Francisco County, Annual

tblLandUse	LotAcreage	0.00	1.27
tblOffRoadEquipment	OffRoadEquipmentUnitAmount	1.00	0.00
tblOffRoadEquipment	OffRoadEquipmentUnitAmount	1.00	0.00
tblOffRoadEquipment	OffRoadEquipmentUnitAmount	1.00	0.00
tblOffRoadEquipment	OffRoadEquipmentUnitAmount	1.00	0.00
tblOffRoadEquipment	UsageHours	6.00	0.00
tblOffRoadEquipment	UsageHours	8.00	0.00
tblOffRoadEquipment	UsageHours	7.00	0.00
tblOffRoadEquipment	UsageHours	8.00	0.00
tblTripsAndVMT	VendorTripNumber	0.00	2.00
tblTripsAndVMT	WorkerTripNumber	20.00	18.00

2.0 Emissions Summary

Islais Creek Ground Improvements - San Francisco County, Annual

2.1 Overall Construction
Unmitigated Construction

Year	tons/yr										MT/yr					
	ROG	NOx	CO	SO2	Fugitive PM10	Exhaust PM10	PM10 Total	Fugitive PM2.5	Exhaust PM2.5	PM2.5 Total	Bio- CO2	NBio- CO2	Total CO2	CH4	N2O	CO2e
2020	0.0501	0.5144	0.3588	9.5000e-004	5.1300e-003	0.0222	0.0273	1.3700e-003	0.0209	0.0223	0.0000	83.6487	83.6487	0.0214	0.0000	84.1845
2021	0.0152	0.1519	0.1167	3.2000e-004	1.7100e-003	6.4300e-003	8.1400e-003	4.6000e-004	6.0400e-003	6.5000e-003	0.0000	27.8449	27.8449	7.1100e-003	0.0000	28.0227
Maximum	0.0501	0.5144	0.3588	9.5000e-004	5.1300e-003	0.0222	0.0273	1.3700e-003	0.0209	0.0223	0.0000	83.6487	83.6487	0.0214	0.0000	84.1845

Mitigated Construction

Year	tons/yr										MT/yr					
	ROG	NOx	CO	SO2	Fugitive PM10	Exhaust PM10	PM10 Total	Fugitive PM2.5	Exhaust PM2.5	PM2.5 Total	Bio- CO2	NBio- CO2	Total CO2	CH4	N2O	CO2e
2020	0.0241	0.6668	0.4566	9.5000e-004	5.1300e-003	2.5800e-003	7.7000e-003	1.3700e-003	2.5700e-003	3.9500e-003	0.0000	74.3227	74.3227	0.0209	0.0000	74.8454
2021	7.9600e-003	0.2220	0.1518	3.2000e-004	1.7100e-003	8.5000e-004	2.5600e-003	4.6000e-004	8.5000e-004	1.3100e-003	0.0000	24.7362	24.7362	6.9600e-003	0.0000	24.9101
Maximum	0.0241	0.6668	0.4566	9.5000e-004	5.1300e-003	2.5800e-003	7.7000e-003	1.3700e-003	2.5700e-003	3.9500e-003	0.0000	74.3227	74.3227	0.0209	0.0000	74.8454

Percent Reduction	ROG	NOx	CO	SO2	Fugitive PM10	Exhaust PM10	PM10 Total	Fugitive PM2.5	Exhaust PM2.5	PM2.5 Total	Bio- CO2	NBio- CO2	Total CO2	CH4	N2O	CO2e
	50.98	-33.41	-27.96	0.00	0.00	88.02	71.07	0.00	87.30	81.70	0.00	11.15	11.15	2.35	0.00	11.10

Islais Creek Ground Improvements - San Francisco County, Annual

Quarter	Start Date	End Date	Maximum Unmitigated ROG + NOX (tons/quarter)	Maximum Mitigated ROG + NOX (tons/quarter)
1	10-1-2020	12-31-2020	0.5623	0.6882
2	1-1-2021	3-31-2021	0.1737	0.2390
		Highest	0.5623	0.6882

2.2 Overall Operational

Unmitigated Operational

Category	tons/yr										MT/yr						
	ROG	NOx	CO	SO2	Fugitive PM10	Exhaust PM10	PM10 Total	Fugitive PM2.5	Exhaust PM2.5	PM2.5 Total	Bio- CO2	NBio- CO2	Total CO2	CH4	N2O	CO2e	
Area	0.0000	0.0000	1.0000e-005	0.0000	0.0000	0.0000	0.0000	0.0000	0.0000	0.0000	0.0000	2.0000e-005	2.0000e-005	0.0000	0.0000	0.0000	2.0000e-005
Energy	0.0000	0.0000	0.0000	0.0000	0.0000	0.0000	0.0000	0.0000	0.0000	0.0000	0.0000	0.0000	0.0000	0.0000	0.0000	0.0000	0.0000
Mobile	0.0000	0.0000	0.0000	0.0000	0.0000	0.0000	0.0000	0.0000	0.0000	0.0000	0.0000	0.0000	0.0000	0.0000	0.0000	0.0000	0.0000
Waste					0.0000	0.0000	0.0000	0.0000	0.0000	0.0000	0.0000	0.0000	0.0000	0.0000	0.0000	0.0000	0.0000
Water					0.0000	0.0000	0.0000	0.0000	0.0000	0.0000	0.0000	0.0000	0.0000	0.0000	0.0000	0.0000	0.0000
Total	0.0000	0.0000	1.0000e-005	0.0000	0.0000	0.0000	0.0000	0.0000	0.0000	0.0000	0.0000	2.0000e-005	2.0000e-005	0.0000	0.0000	0.0000	2.0000e-005

Islais Creek Ground Improvements - San Francisco County, Annual

2.2 Overall Operational

Mitigated Operational

Category	tons/yr											MT/yr					
	ROG	NOx	CO	SO2	Fugitive PM10	Exhaust PM10	PM10 Total	Fugitive PM2.5	Exhaust PM2.5	PM2.5 Total	Bio- CO2	NBio- CO2	Total CO2	CH4	N2O	CO2e	
Area	0.0000	0.0000	1.0000e-005	0.0000	0.0000	0.0000	0.0000	0.0000	0.0000	0.0000	0.0000	2.0000e-005	2.0000e-005	0.0000	0.0000	0.0000	2.0000e-005
Energy	0.0000	0.0000	0.0000	0.0000	0.0000	0.0000	0.0000	0.0000	0.0000	0.0000	0.0000	0.0000	0.0000	0.0000	0.0000	0.0000	0.0000
Mobile	0.0000	0.0000	0.0000	0.0000	0.0000	0.0000	0.0000	0.0000	0.0000	0.0000	0.0000	0.0000	0.0000	0.0000	0.0000	0.0000	0.0000
Waste	0.0000	0.0000	0.0000	0.0000	0.0000	0.0000	0.0000	0.0000	0.0000	0.0000	0.0000	0.0000	0.0000	0.0000	0.0000	0.0000	0.0000
Water	0.0000	0.0000	0.0000	0.0000	0.0000	0.0000	0.0000	0.0000	0.0000	0.0000	0.0000	0.0000	0.0000	0.0000	0.0000	0.0000	0.0000
Total	0.0000	0.0000	1.0000e-005	0.0000	0.0000	0.0000	0.0000	0.0000	0.0000	0.0000	0.0000	2.0000e-005	2.0000e-005	0.0000	0.0000	0.0000	2.0000e-005

Percent Reduction	tons/yr											MT/yr				
	ROG	NOx	CO	SO2	Fugitive PM10	Exhaust PM10	PM10 Total	Fugitive PM2.5	Exhaust PM2.5	PM2.5 Total	Bio- CO2	NBio- CO2	Total CO2	CH4	N2O	CO2e
0.00	0.00	0.00	0.00	0.00	0.00	0.00	0.00	0.00	0.00	0.00	0.00	0.00	0.00	0.00	0.00	0.00

3.0 Construction Detail

Construction Phase

Phase Number	Phase Name	Phase Type	Start Date	End Date	Num Days Week	Num Days	Phase Description
1	Trenching	Trenching	10/1/2020	2/1/2021	5	88	
2	Site Preparation	Site Preparation	10/29/2020	10/28/2020	5	0	
3	Architectural Coating	Architectural Coating	8/27/2021	8/26/2021	5	0	

Islais Creek Ground Improvements - San Francisco County, Annual

Acres of Grading (Site Preparation Phase): 1

Acres of Grading (Grading Phase): 0

Acres of Paving: 0

Residential Indoor: 0; Residential Outdoor: 0; Non-Residential Indoor: 0; Non-Residential Outdoor: 0; Striped Parking Area: 0 (Architectural Coating – sqft)

OffRoad Equipment

Phase Name	Offroad Equipment Type	Amount	Usage Hours	Horse Power	Load Factor
Site Preparation	Graders	0	0.00	187	0.41
Site Preparation	Rubber Tired Dozers	0	0.00	247	0.40
Site Preparation	Tractors/Loaders/Backhoes	0	0.00	97	0.37
Architectural Coating	Air Compressors	0	0.00	78	0.48
Trenching	Air Compressors	1	4.00	78	0.48
Trenching	Bore/Drill Rigs	1	8.00	221	0.50
Trenching	Cranes	1	8.00	231	0.29
Trenching	Excavators	1	1.00	158	0.38
Trenching	Generator Sets	1	4.00	84	0.74
Trenching	Off-Highway Trucks	1	2.00	402	0.38
Trenching	Plate Compactors	1	2.00	8	0.43
Trenching	Tractors/Loaders/Backhoes	1	6.00	97	0.37

Trips and VMT

Islais Creek Ground Improvements - San Francisco County, Annual

Phase Name	Offroad Equipment Count	Worker Trip Number	Vendor Trip Number	Hauling Trip Number	Worker Trip Length	Vendor Trip Length	Hauling Trip Length	Worker Vehicle Class	Vendor Vehicle Class	Hauling Vehicle Class
Site Preparation	0	0.00	0.00	0.00	10.80	7.30	20.00	LD_Mix	HDT_Mix	HHDT
Architectural Coating	0	0.00	0.00	0.00	10.80	7.30	20.00	LD_Mix	HDT_Mix	HHDT
Trenching	8	18.00	2.00	0.00	10.80	7.30	20.00	LD_Mix	HDT_Mix	HHDT

3.1 Mitigation Measures Construction

- Use Alternative Fuel for Construction Equipment
- Use Cleaner Engines for Construction Equipment
- Use DPF for Construction Equipment
- Water Exposed Area

3.2 Trenching - 2020

Unmitigated Construction On-Site

Category	ROG	NOx	CO	SO2	Fugitive PM10	Exhaust PM10	PM10 Total	Fugitive PM2.5	Exhaust PM2.5	PM2.5 Total	Bio- CO2	NBio- CO2	Total CO2	CH4	N2O	CO2e
Off-Road	0.0480	0.5049	0.3430	8.9000e-004	0.0221	0.0221	0.0221	0.0208	0.0208	0.0208	0.0000	77.3608	77.3608	0.0211	0.0000	77.8881
Total	0.0480	0.5049	0.3430	8.9000e-004	0.0221	0.0221	0.0221	0.0208	0.0208	0.0208	0.0000	77.3608	77.3608	0.0211	0.0000	77.8881

Islais Creek Ground Improvements - San Francisco County, Annual

3.2 Trenching - 2020
Unmitigated Construction Off-Site

Category	tons/yr										MT/yr					
	ROG	NOx	CO	SO2	Fugitive PM10	Exhaust PM10	PM10 Total	Fugitive PM2.5	Exhaust PM2.5	PM2.5 Total	Bio- CO2	NBio- CO2	Total CO2	CH4	N2O	CO2e
Hauling	0.0000	0.0000	0.0000	0.0000	0.0000	0.0000	0.0000	0.0000	0.0000	0.0000	0.0000	0.0000	0.0000	0.0000	0.0000	0.0000
Vendor	2.4000e-004	8.2600e-003	2.4400e-003	2.0000e-005	4.3000e-004	4.0000e-005	4.7000e-004	1.2000e-004	3.0000e-005	1.6000e-004	0.0000	1.8270	1.8270	2.4000e-004	0.0000	1.8330
Worker	1.8100e-003	1.2000e-003	0.0134	5.0000e-005	4.6900e-003	4.0000e-005	4.7300e-003	1.2500e-003	3.0000e-005	1.2800e-003	0.0000	4.4609	4.4609	1.0000e-004	0.0000	4.4634
Total	2.0500e-003	9.4600e-003	0.0158	7.0000e-005	5.1200e-003	8.0000e-005	5.2000e-003	1.3700e-003	6.0000e-005	1.4400e-003	0.0000	6.2879	6.2879	3.4000e-004	0.0000	6.2964

Mitigated Construction On-Site

Category	tons/yr										MT/yr					
	ROG	NOx	CO	SO2	Fugitive PM10	Exhaust PM10	PM10 Total	Fugitive PM2.5	Exhaust PM2.5	PM2.5 Total	Bio- CO2	NBio- CO2	Total CO2	CH4	N2O	CO2e
Off-Road	0.0220	0.6573	0.4408	8.9000e-004		2.5100e-003	2.5100e-003		2.5100e-003	2.5100e-003	0.0000	68.0348	68.0348	0.0206	0.0000	68.5490
Total	0.0220	0.6573	0.4408	8.9000e-004		2.5100e-003	2.5100e-003		2.5100e-003	2.5100e-003	0.0000	68.0348	68.0348	0.0206	0.0000	68.5490

Islais Creek Ground Improvements - San Francisco County, Annual

3.2 Trenching - 2020

Mitigated Construction Off-Site

Category	tons/yr										MT/yr						
	ROG	NOx	CO	SO2	Fugitive PM10	Exhaust PM10	PM10 Total	Fugitive PM2.5	Exhaust PM2.5	PM2.5 Total	Bio- CO2	NBio- CO2	Total CO2	CH4	N2O	CO2e	
Hauling	0.0000	0.0000	0.0000	0.0000	0.0000	0.0000	0.0000	0.0000	0.0000	0.0000	0.0000	0.0000	0.0000	0.0000	0.0000	0.0000	0.0000
Vendor	2.4000e-004	8.2600e-003	2.4400e-003	2.0000e-005	4.3000e-004	4.0000e-005	4.7000e-004	1.2000e-004	3.0000e-005	1.6000e-004	0.0000	1.8270	1.8270	2.4000e-004	0.0000	0.0000	1.8330
Worker	1.8100e-003	1.2000e-003	0.0134	5.0000e-005	4.6900e-003	4.0000e-005	4.7300e-003	1.2500e-003	3.0000e-005	1.2800e-003	0.0000	4.4609	4.4609	1.0000e-004	0.0000	0.0000	4.4634
Total	2.0500e-003	9.4600e-003	0.0158	7.0000e-005	5.1200e-003	8.0000e-005	5.2000e-003	1.3700e-003	6.0000e-005	1.4400e-003	0.0000	6.2879	6.2879	3.4000e-004	0.0000	0.0000	6.2964

3.2 Trenching - 2021

Unmitigated Construction On-Site

Category	tons/yr										MT/yr						
	ROG	NOx	CO	SO2	Fugitive PM10	Exhaust PM10	PM10 Total	Fugitive PM2.5	Exhaust PM2.5	PM2.5 Total	Bio- CO2	NBio- CO2	Total CO2	CH4	N2O	CO2e	
Off-Road	0.0146	0.1490	0.1119	3.0000e-004	6.4100e-003	6.4100e-003	6.4100e-003	6.0300e-003	6.0300e-003	6.0300e-003	0.0000	25.8098	25.8098	7.0000e-003	0.0000	0.0000	25.9849
Total	0.0146	0.1490	0.1119	3.0000e-004	6.4100e-003	6.4100e-003	6.4100e-003	6.0300e-003	6.0300e-003	6.0300e-003	0.0000	25.8098	25.8098	7.0000e-003	0.0000	0.0000	25.9849

Islais Creek Ground Improvements - San Francisco County, Annual

3.2 Trenching - 2021
Unmitigated Construction Off-Site

Category	tons/yr										MT/yr					
	ROG	NOx	CO	SO2	Fugitive PM10	Exhaust PM10	PM10 Total	Fugitive PM2.5	Exhaust PM2.5	PM2.5 Total	Bio- CO2	NBio- CO2	Total CO2	CH4	N2O	CO2e
Hauling	0.0000	0.0000	0.0000	0.0000	0.0000	0.0000	0.0000	0.0000	0.0000	0.0000	0.0000	0.0000	0.0000	0.0000	0.0000	0.0000
Vendor	7.0000e-005	2.5200e-003	7.7000e-004	1.0000e-005	1.4000e-004	1.0000e-005	1.5000e-004	1.0000e-005	1.0000e-005	5.0000e-005	0.0000	0.6012	0.6012	8.0000e-005	0.0000	0.6032
Worker	5.6000e-004	3.6000e-004	4.1200e-003	2.0000e-005	1.5600e-003	1.0000e-005	1.5800e-003	1.0000e-005	1.0000e-005	4.3000e-004	0.0000	1.4339	1.4339	3.0000e-005	0.0000	1.4346
Total	6.3000e-004	2.8800e-003	4.8900e-003	3.0000e-005	1.7000e-003	2.0000e-005	1.7300e-003	4.6000e-004	2.0000e-005	4.8000e-004	0.0000	2.0351	2.0351	1.1000e-004	0.0000	2.0378

Mitigated Construction On-Site

Category	tons/yr										MT/yr					
	ROG	NOx	CO	SO2	Fugitive PM10	Exhaust PM10	PM10 Total	Fugitive PM2.5	Exhaust PM2.5	PM2.5 Total	Bio- CO2	NBio- CO2	Total CO2	CH4	N2O	CO2e
Off-Road	7.3300e-003	0.2191	0.1469	3.0000e-004		8.4000e-004	8.4000e-004		8.4000e-004	8.4000e-004	0.0000	22.7011	22.7011	6.8500e-003	0.0000	22.8723
Total	7.3300e-003	0.2191	0.1469	3.0000e-004		8.4000e-004	8.4000e-004		8.4000e-004	8.4000e-004	0.0000	22.7011	22.7011	6.8500e-003	0.0000	22.8723

Islais Creek Ground Improvements - San Francisco County, Annual

3.4 Architectural Coating - 2021

Mitigated Construction Off-Site

Category	tons/yr										MT/yr						
	ROG	NOx	CO	SO2	Fugitive PM10	Exhaust PM10	PM10 Total	Fugitive PM2.5	Exhaust PM2.5	PM2.5 Total	Bio- CO2	NBio- CO2	Total CO2	CH4	N2O	CO2e	
Hauling	0.0000	0.0000	0.0000	0.0000	0.0000	0.0000	0.0000	0.0000	0.0000	0.0000	0.0000	0.0000	0.0000	0.0000	0.0000	0.0000	0.0000
Vendor	0.0000	0.0000	0.0000	0.0000	0.0000	0.0000	0.0000	0.0000	0.0000	0.0000	0.0000	0.0000	0.0000	0.0000	0.0000	0.0000	0.0000
Worker	0.0000	0.0000	0.0000	0.0000	0.0000	0.0000	0.0000	0.0000	0.0000	0.0000	0.0000	0.0000	0.0000	0.0000	0.0000	0.0000	0.0000
Total	0.0000	0.0000	0.0000	0.0000	0.0000	0.0000	0.0000	0.0000	0.0000	0.0000	0.0000	0.0000	0.0000	0.0000	0.0000	0.0000	0.0000

4.0 Operational Detail - Mobile

4.1 Mitigation Measures Mobile

Islais Creek Ground Improvements - San Francisco County, Annual

Category	tons/yr													MT/yr			
	ROG	NOx	CO	SO2	Fugitive PM10	Exhaust PM10	PM10 Total	Fugitive PM2.5	Exhaust PM2.5	PM2.5 Total	Bio- CO2	NBio- CO2	Total CO2	CH4	N2O	CO2e	
Mitigated	0.0000	0.0000	0.0000	0.0000	0.0000	0.0000	0.0000	0.0000	0.0000	0.0000	0.0000	0.0000	0.0000	0.0000	0.0000	0.0000	
Unmitigated	0.0000	0.0000	0.0000	0.0000	0.0000	0.0000	0.0000	0.0000	0.0000	0.0000	0.0000	0.0000	0.0000	0.0000	0.0000	0.0000	

4.2 Trip Summary Information

Land Use	Average Daily Trip Rate			Unmitigated		Mitigated	
	Weekday	Saturday	Sunday	Annual VMT	Annual VMT	Annual VMT	Annual VMT
User Defined Industrial	0.00	0.00	0.00				
Total	0.00	0.00	0.00				

4.3 Trip Type Information

Land Use	Miles						Trip %			Trip Purpose %		
	H-W or C-C	H-S or C-C	H-O or C-NW	H-W or C-W	H-S or C-C	H-O or C-NW	Primary	Diverted	Pass-by	Primary	Diverted	Pass-by
User Defined Industrial	9.50	7.30	7.30	0.00	0.00	0.00	0	0	0	0	0	0

4.4 Fleet Mix

Land Use	LDA	LDT1	LDT2	MDV	LHD1	LHD2	MHD	HHD	OBUS	UBUS	MCY	SBUS	MH
User Defined Industrial	0.606408	0.040118	0.191445	0.088323	0.014900	0.004926	0.028280	0.008891	0.004289	0.004272	0.006741	0.000931	0.000477

5.0 Energy Detail

Historical Energy Use: N

Islais Creek Ground Improvements - San Francisco County, Annual

5.2 Energy by Land Use - Natural Gas

Mitigated

Land Use	Natural Gas Use kBtu/yr	tons/yr										MT/yr						
		ROG	NOx	CO	SO2	Fugitive PM10	Exhaust PM10	PM10 Total	Fugitive PM2.5	Exhaust PM2.5	PM2.5 Total	Bio-CO2	NBio-CO2	Total CO2	CH4	N2O	CO2e	
User Defined Industrial	0	0.0000	0.0000	0.0000	0.0000	0.0000	0.0000	0.0000	0.0000	0.0000	0.0000	0.0000	0.0000	0.0000	0.0000	0.0000	0.0000	0.0000
Total		0.0000	0.0000	0.0000	0.0000	0.0000	0.0000	0.0000	0.0000	0.0000	0.0000	0.0000	0.0000	0.0000	0.0000	0.0000	0.0000	0.0000

5.3 Energy by Land Use - Electricity

Unmitigated

Land Use	Electricity Use kWh/yr	MT/yr				
		Total CO2	CH4	N2O	CO2e	
User Defined Industrial	0	0.0000	0.0000	0.0000	0.0000	0.0000
Total		0.0000	0.0000	0.0000	0.0000	0.0000

Islais Creek Ground Improvements - San Francisco County, Annual

5.3 Energy by Land Use - Electricity

Mitigated

Land Use	Electricity Use kWh/yr	Total CO2	CH4	N2O	CO2e
User Defined Industrial	0	0.0000	0.0000	0.0000	0.0000
Total		0.0000	0.0000	0.0000	0.0000

6.0 Area Detail

6.1 Mitigation Measures Area

Category	tons/yr											MT/yr					
	ROG	NOx	CO	SO2	Fugitive PM10	Exhaust PM10	PM10 Total	Fugitive PM2.5	Exhaust PM2.5	PM2.5 Total	Bio- CO2	NBio- CO2	Total CO2	CH4	N2O	CO2e	
Mitigated	0.0000	0.0000	1.0000e-005	0.0000	0.0000	0.0000	0.0000	0.0000	0.0000	0.0000	0.0000	2.0000e-005	2.0000e-005	0.0000	0.0000	0.0000	2.0000e-005
Unmitigated	0.0000	0.0000	1.0000e-005	0.0000	0.0000	0.0000	0.0000	0.0000	0.0000	0.0000	0.0000	2.0000e-005	2.0000e-005	0.0000	0.0000	0.0000	2.0000e-005

Islais Creek Ground Improvements - San Francisco County, Annual

6.2 Area by SubCategory

Unmitigated

SubCategory	tons/yr										MT/yr					
	ROG	NOx	CO	SO2	Fugitive PM10	Exhaust PM10	PM10 Total	Fugitive PM2.5	Exhaust PM2.5	PM2.5 Total	Bio- CO2	NBio- CO2	Total CO2	CH4	N2O	CO2e
Architectural Coating	0.0000					0.0000	0.0000	0.0000	0.0000	0.0000	0.0000	0.0000	0.0000	0.0000	0.0000	0.0000
Consumer Products	0.0000					0.0000	0.0000	0.0000	0.0000	0.0000	0.0000	0.0000	0.0000	0.0000	0.0000	0.0000
Landscaping	0.0000	0.0000	1.0000e-005	0.0000		0.0000	0.0000	0.0000	0.0000	0.0000	0.0000	2.0000e-005	2.0000e-005	0.0000	0.0000	2.0000e-005
Total	0.0000	0.0000	1.0000e-005	0.0000		0.0000	0.0000	0.0000	0.0000	0.0000	0.0000	2.0000e-005	2.0000e-005	0.0000	0.0000	2.0000e-005

Mitigated

SubCategory	tons/yr										MT/yr					
	ROG	NOx	CO	SO2	Fugitive PM10	Exhaust PM10	PM10 Total	Fugitive PM2.5	Exhaust PM2.5	PM2.5 Total	Bio- CO2	NBio- CO2	Total CO2	CH4	N2O	CO2e
Architectural Coating	0.0000					0.0000	0.0000	0.0000	0.0000	0.0000	0.0000	0.0000	0.0000	0.0000	0.0000	0.0000
Consumer Products	0.0000					0.0000	0.0000	0.0000	0.0000	0.0000	0.0000	0.0000	0.0000	0.0000	0.0000	0.0000
Landscaping	0.0000	0.0000	1.0000e-005	0.0000		0.0000	0.0000	0.0000	0.0000	0.0000	0.0000	2.0000e-005	2.0000e-005	0.0000	0.0000	2.0000e-005
Total	0.0000	0.0000	1.0000e-005	0.0000		0.0000	0.0000	0.0000	0.0000	0.0000	0.0000	2.0000e-005	2.0000e-005	0.0000	0.0000	2.0000e-005

7.0 Water Detail

7.1 Mitigation Measures Water

	Total CO2	CH4	N2O	CO2e
Category	MT/yr			
Mitigated	0.0000	0.0000	0.0000	0.0000
Unmitigated	0.0000	0.0000	0.0000	0.0000

7.2 Water by Land Use

Unmitigated

	Indoor/Outdoor Use	Total CO2	CH4	N2O	CO2e
Land Use	Mgal				
User Defined Industrial	0 / 0	0.0000	0.0000	0.0000	0.0000
Total		0.0000	0.0000	0.0000	0.0000

Islais Creek Ground Improvements - San Francisco County, Annual

7.2 Water by Land Use

Mitigated

Land Use	Indoor/Outdoor Use	Total CO2	CH4	N2O	CO2e
	Mgal	MT/yr			
User Defined Industrial	0 / 0	0.0000	0.0000	0.0000	0.0000
Total		0.0000	0.0000	0.0000	0.0000

8.0 Waste Detail

8.1 Mitigation Measures Waste

Category/Year

Category/Year	Total CO2	CH4	N2O	CO2e
	MT/yr			
Mitigated	0.0000	0.0000	0.0000	0.0000
Unmitigated	0.0000	0.0000	0.0000	0.0000

Islais Creek Ground Improvements - San Francisco County, Annual

8.2 Waste by Land Use

Unmitigated

Land Use	Waste Disposed tons	Total CO2				CO2e
		CH4	N2O	MT/yr		
User Defined Industrial	0	0.0000	0.0000	0.0000	0.0000	0.0000
Total		0.0000	0.0000	0.0000	0.0000	0.0000

Mitigated

Land Use	Waste Disposed tons	Total CO2				CO2e
		CH4	N2O	MT/yr		
User Defined Industrial	0	0.0000	0.0000	0.0000	0.0000	0.0000
Total		0.0000	0.0000	0.0000	0.0000	0.0000

9.0 Operational Offroad

Equipment Type	Number	Hours/Day	Days/Year	Horse Power	Load Factor	Fuel Type
----------------	--------	-----------	-----------	-------------	-------------	-----------

Islais Creek Ground Improvements - San Francisco County, Annual

10.0 Stationary Equipment

Fire Pumps and Emergency Generators

Equipment Type	Number	Hours/Day	Hours/Year	Horse Power	Load Factor	Fuel Type
----------------	--------	-----------	------------	-------------	-------------	-----------

Boilers

Equipment Type	Number	Heat Input/Day	Heat Input/Year	Boiler Rating	Fuel Type
----------------	--------	----------------	-----------------	---------------	-----------

User Defined Equipment

Equipment Type	Number
----------------	--------

11.0 Vegetation

Islais Creek Ground Improvements - San Francisco County, Annual

Islais Creek Ground Improvements
San Francisco County, Annual

1.0 Project Characteristics

1.1 Land Usage

Land Uses	Size	Metric	Lot Acreage	Floor Surface Area	Population
User Defined Industrial	1.00	User Defined Unit	1.27	0.00	0

1.2 Other Project Characteristics

Urbanization	Urban	Wind Speed (m/s)	4.6	Precipitation Freq (Days)	64
Climate Zone	5			Operational Year	2021

Utility Company Pacific Gas & Electric Company

CO2 Intensity (lb/MW/hr)	641.35	CH4 Intensity (lb/MW/hr)	0.029	N2O Intensity (lb/MW/hr)	0.006
---------------------------------	--------	---------------------------------	-------	---------------------------------	-------

1.3 User Entered Comments & Non-Default Data

Project Characteristics -

Land Use - Construction only run for ground improvements. Project acreage based on trenching limits.

Construction Phase - Project specific construction schedule.

Off-road Equipment - Modeled under one phase.

Off-road Equipment - Modeled under one phase.

Off-road Equipment - Project specific construction equipment.

Trips and VMT - Based on 9 workers per day and approximately one pick-up truck per day.

Grading - Default acres graded. Material import and export quantities included in DB129.1 and DB129.2 runs.

Construction Off-road Equipment Mitigation - Assumes fugitive dust control and use of Tier 4 Final. Generator assumed to be electric.

Islais Creek Ground Improvements - San Francisco County, Annual

Table Name	Column Name	Default Value	New Value
tblConstEquipMitigation	FuelType	Diesel	Electrical
tblConstEquipMitigation	NumberOfEquipmentMitigated	0.00	1.00
tblConstEquipMitigation	NumberOfEquipmentMitigated	0.00	1.00
tblConstEquipMitigation	NumberOfEquipmentMitigated	0.00	1.00
tblConstEquipMitigation	NumberOfEquipmentMitigated	0.00	1.00
tblConstEquipMitigation	NumberOfEquipmentMitigated	0.00	1.00
tblConstEquipMitigation	NumberOfEquipmentMitigated	0.00	1.00
tblConstEquipMitigation	NumberOfEquipmentMitigated	0.00	1.00
tblConstEquipMitigation	NumberOfEquipmentMitigated	0.00	1.00
tblConstEquipMitigation	NumberOfEquipmentMitigated	0.00	1.00
tblConstEquipMitigation	Tier	No Change	Tier 4 Final
tblConstEquipMitigation	Tier	No Change	Tier 4 Final
tblConstEquipMitigation	Tier	No Change	Tier 4 Final
tblConstEquipMitigation	Tier	No Change	Tier 4 Final
tblConstEquipMitigation	Tier	No Change	Tier 4 Final
tblConstEquipMitigation	Tier	No Change	Tier 4 Final
tblConstEquipMitigation	Tier	No Change	Tier 4 Final
tblConstructionPhase	NumDays	10.00	0.00
tblConstructionPhase	NumDays	2.00	0.00
tblGrading	AcresOfGrading	0.00	1.00
tblLandUse	LotAcreage	0.00	1.27
tblOffRoadEquipment	OffRoadEquipmentUnitAmount	1.00	0.00
tblOffRoadEquipment	OffRoadEquipmentUnitAmount	1.00	0.00
tblOffRoadEquipment	OffRoadEquipmentUnitAmount	1.00	0.00
tblOffRoadEquipment	OffRoadEquipmentUnitAmount	1.00	0.00
tblOffRoadEquipment	UsageHours	6.00	0.00
tblOffRoadEquipment	UsageHours	8.00	0.00

Islais Creek Ground Improvements - San Francisco County, Annual

tblOffRoadEquipment	UsageHours	7.00	0.00
tblOffRoadEquipment	UsageHours	8.00	0.00
tblTripsAndVMT	VendorTripNumber	0.00	2.00
tblTripsAndVMT	WorkerTripNumber	20.00	18.00

2.0 Emissions Summary

Islais Creek Ground Improvements - San Francisco County, Annual

**2.1 Overall Construction
Unmitigated Construction**

Year	tons/yr											MT/yr				
	ROG	NOx	CO	SO2	Fugitive PM10	Exhaust PM10	PM10 Total	Fugitive PM2.5	Exhaust PM2.5	PM2.5 Total	Bio- CO2	NBio- CO2	Total CO2	CH4	N2O	CO2e
2020	0.0501	0.5144	0.3588	9.5000e-004	5.1300e-003	0.0222	0.0273	1.3700e-003	0.0209	0.0223	0.0000	83.6487	83.6487	0.0214	0.0000	84.1845
2021	0.0152	0.1519	0.1167	3.2000e-004	1.7100e-003	6.4300e-003	8.1400e-003	4.6000e-004	6.0400e-003	6.5000e-003	0.0000	27.8449	27.8449	7.1100e-003	0.0000	28.0227
Maximum	0.0501	0.5144	0.3588	9.5000e-004	5.1300e-003	0.0222	0.0273	1.3700e-003	0.0209	0.0223	0.0000	83.6487	83.6487	0.0214	0.0000	84.1845

Mitigated Construction

Year	tons/yr											MT/yr				
	ROG	NOx	CO	SO2	Fugitive PM10	Exhaust PM10	PM10 Total	Fugitive PM2.5	Exhaust PM2.5	PM2.5 Total	Bio- CO2	NBio- CO2	Total CO2	CH4	N2O	CO2e
2020	0.0114	0.0501	0.4064	9.5000e-004	5.1300e-003	1.3200e-003	6.4500e-003	1.3200e-003	1.3200e-003	2.6900e-003	0.0000	74.3227	74.3227	0.0209	0.0000	74.8454
2021	3.7600e-003	0.0164	0.1351	3.2000e-004	1.7100e-003	4.3000e-004	2.1400e-003	4.3000e-004	4.3000e-004	8.9000e-004	0.0000	24.7362	24.7362	6.9600e-003	0.0000	24.9101
Maximum	0.0114	0.0501	0.4064	9.5000e-004	5.1300e-003	1.3200e-003	6.4500e-003	1.3200e-003	1.3200e-003	2.6900e-003	0.0000	74.3227	74.3227	0.0209	0.0000	74.8454

ROG	NOx	CO	SO2	Fugitive PM10	Exhaust PM10	PM10 Total	Fugitive PM2.5	Exhaust PM2.5	PM2.5 Total	Bio- CO2	NBio- CO2	Total CO2	CH4	N2O	CO2e
Percent Reduction	76.72	90.01	-13.88	0.00	93.89	75.78	0.00	93.50	87.55	0.00	11.15	11.15	2.35	0.00	11.10

Islais Creek Ground Improvements - San Francisco County, Annual

Quarter	Start Date	End Date	Maximum Unmitigated ROG + NOX (tons/quarter)	Maximum Mitigated ROG + NOX (tons/quarter)
1	10-1-2020	12-31-2020	0.5623	0.0616
2	1-1-2021	3-31-2021	0.1737	0.0211
		Highest	0.5623	0.0616

2.2 Overall Operational
Unmitigated Operational

Category	tons/yr										MT/yr						
	ROG	NOx	CO	SO2	Fugitive PM10	Exhaust PM10	PM10 Total	Fugitive PM2.5	Exhaust PM2.5	PM2.5 Total	Bio- CO2	NBio- CO2	Total CO2	CH4	N2O	CO2e	
Area	0.0000	0.0000	1.0000e-005	0.0000	0.0000	0.0000	0.0000	0.0000	0.0000	0.0000	0.0000	2.0000e-005	2.0000e-005	0.0000	0.0000	0.0000	2.0000e-005
Energy	0.0000	0.0000	0.0000	0.0000	0.0000	0.0000	0.0000	0.0000	0.0000	0.0000	0.0000	0.0000	0.0000	0.0000	0.0000	0.0000	0.0000
Mobile	0.0000	0.0000	0.0000	0.0000	0.0000	0.0000	0.0000	0.0000	0.0000	0.0000	0.0000	0.0000	0.0000	0.0000	0.0000	0.0000	0.0000
Waste																	
Water																	
Total	0.0000	0.0000	1.0000e-005	0.0000	0.0000	0.0000	0.0000	0.0000	0.0000	0.0000	0.0000	2.0000e-005	2.0000e-005	0.0000	0.0000	0.0000	2.0000e-005

Islais Creek Ground Improvements - San Francisco County, Annual

2.2 Overall Operational

Mitigated Operational

Category	tons/yr											MT/yr					
	ROG	NOx	CO	SO2	Fugitive PM10	Exhaust PM10	PM10 Total	Fugitive PM2.5	Exhaust PM2.5	PM2.5 Total	Bio- CO2	NBio- CO2	Total CO2	CH4	N2O	CO2e	
Area	0.0000	0.0000	1.0000e-005	0.0000	0.0000	0.0000	0.0000	0.0000	0.0000	0.0000	0.0000	2.0000e-005	2.0000e-005	0.0000	0.0000	0.0000	2.0000e-005
Energy	0.0000	0.0000	0.0000	0.0000	0.0000	0.0000	0.0000	0.0000	0.0000	0.0000	0.0000	0.0000	0.0000	0.0000	0.0000	0.0000	0.0000
Mobile	0.0000	0.0000	0.0000	0.0000	0.0000	0.0000	0.0000	0.0000	0.0000	0.0000	0.0000	0.0000	0.0000	0.0000	0.0000	0.0000	0.0000
Waste																	
Water																	
Total	0.0000	0.0000	1.0000e-005	0.0000	0.0000	0.0000	0.0000	0.0000	0.0000	0.0000	0.0000	2.0000e-005	2.0000e-005	0.0000	0.0000	0.0000	2.0000e-005

Percent Reduction	tons/yr										MT/yr					
	ROG	NOx	CO	SO2	Fugitive PM10	Exhaust PM10	PM10 Total	Fugitive PM2.5	Exhaust PM2.5	PM2.5 Total	Bio- CO2	NBio- CO2	Total CO2	CH4	N2O	CO2e
0.00	0.00	0.00	0.00	0.00	0.00	0.00	0.00	0.00	0.00	0.00	0.00	0.00	0.00	0.00	0.00	0.00

3.0 Construction Detail

Construction Phase

Phase Number	Phase Name	Phase Type	Start Date	End Date	Num Days Week	Num Days	Phase Description
1	Trenching	Trenching	10/1/2020	2/1/2021	5	88	
2	Site Preparation	Site Preparation	10/29/2020	10/28/2020	5	0	
3	Architectural Coating	Architectural Coating	8/27/2021	8/26/2021	5	0	

Islais Creek Ground Improvements - San Francisco County, Annual

Acres of Grading (Site Preparation Phase): 1

Acres of Grading (Grading Phase): 0

Acres of Paving: 0

Residential Indoor: 0; Residential Outdoor: 0; Non-Residential Indoor: 0; Non-Residential Outdoor: 0; Striped Parking Area: 0 (Architectural Coating – sqft)

OffRoad Equipment

Phase Name	Offroad Equipment Type	Amount	Usage Hours	Horse Power	Load Factor
Site Preparation	Graders	0	0.00	187	0.41
Site Preparation	Rubber Tired Dozers	0	0.00	247	0.40
Site Preparation	Tractors/Loaders/Backhoes	0	0.00	97	0.37
Architectural Coating	Air Compressors	0	0.00	78	0.48
Trenching	Air Compressors	1	4.00	78	0.48
Trenching	Bore/Drill Rigs	1	8.00	221	0.50
Trenching	Cranes	1	8.00	231	0.29
Trenching	Excavators	1	1.00	158	0.38
Trenching	Generator Sets	1	4.00	84	0.74
Trenching	Off-Highway Trucks	1	2.00	402	0.38
Trenching	Plate Compactors	1	2.00	8	0.43
Trenching	Tractors/Loaders/Backhoes	1	6.00	97	0.37

Trips and VMT

Islais Creek Ground Improvements - San Francisco County, Annual

Phase Name	Offroad Equipment Count	Worker Trip Number	Vendor Trip Number	Hauling Trip Number	Worker Trip Length	Vendor Trip Length	Hauling Trip Length	Worker Vehicle Class	Vendor Vehicle Class	Hauling Vehicle Class
Site Preparation	0	0.00	0.00	0.00	10.80	7.30	20.00	LD_Mix	HDT_Mix	HHDT
Architectural Coating	0	0.00	0.00	0.00	10.80	7.30	20.00	LD_Mix	HDT_Mix	HHDT
Trenching	8	18.00	2.00	0.00	10.80	7.30	20.00	LD_Mix	HDT_Mix	HHDT

3.1 Mitigation Measures Construction

- Use Alternative Fuel for Construction Equipment
- Use Cleaner Engines for Construction Equipment
- Water Exposed Area

3.2 Trenching - 2020

Unmitigated Construction On-Site

Category	ROG	NOx	CO	SO2	Fugitive PM10	Exhaust PM10	PM10 Total	Fugitive PM2.5	Exhaust PM2.5	PM2.5 Total	Bio- CO2	NBio- CO2	Total CO2	CH4	N2O	CO2e
	tons/yr															
Off-Road	0.0480	0.5049	0.3430	8.9000e-004	0.0221	0.0221	0.0221	0.0208	0.0208	0.0208	0.0000	77.3608	77.3608	0.0211	0.0000	77.8881
Total	0.0480	0.5049	0.3430	8.9000e-004	0.0221	0.0221	0.0221	0.0208	0.0208	0.0208	0.0000	77.3608	77.3608	0.0211	0.0000	77.8881

Islais Creek Ground Improvements - San Francisco County, Annual

3.2 Trenching - 2020
Unmitigated Construction Off-Site

Category	tons/yr										MT/yr					
	ROG	NOx	CO	SO2	Fugitive PM10	Exhaust PM10	PM10 Total	Fugitive PM2.5	Exhaust PM2.5	PM2.5 Total	Bio- CO2	NBio- CO2	Total CO2	CH4	N2O	CO2e
Hauling	0.0000	0.0000	0.0000	0.0000	0.0000	0.0000	0.0000	0.0000	0.0000	0.0000	0.0000	0.0000	0.0000	0.0000	0.0000	0.0000
Vendor	2.4000e-004	8.2600e-003	2.4400e-003	2.0000e-005	4.3000e-004	4.0000e-005	4.7000e-004	1.2000e-004	3.0000e-005	1.6000e-004	0.0000	1.8270	1.8270	2.4000e-004	0.0000	1.8330
Worker	1.8100e-003	1.2000e-003	0.0134	5.0000e-005	4.6900e-003	4.0000e-005	4.7300e-003	1.2500e-003	3.0000e-005	1.2800e-003	0.0000	4.4609	4.4609	1.0000e-004	0.0000	4.4634
Total	2.0500e-003	9.4600e-003	0.0158	7.0000e-005	5.1200e-003	8.0000e-005	5.2000e-003	1.3700e-003	6.0000e-005	1.4400e-003	0.0000	6.2879	6.2879	3.4000e-004	0.0000	6.2964

Mitigated Construction On-Site

Category	tons/yr										MT/yr					
	ROG	NOx	CO	SO2	Fugitive PM10	Exhaust PM10	PM10 Total	Fugitive PM2.5	Exhaust PM2.5	PM2.5 Total	Bio- CO2	NBio- CO2	Total CO2	CH4	N2O	CO2e
Off-Road	9.3900e-003	0.0407	0.3906	8.9000e-004	1.2500e-003	1.2500e-003	1.2500e-003	1.2500e-003	1.2500e-003	1.2500e-003	0.0000	68.0348	68.0348	0.0206	0.0000	68.5490
Total	9.3900e-003	0.0407	0.3906	8.9000e-004	1.2500e-003	1.2500e-003	1.2500e-003	1.2500e-003	1.2500e-003	1.2500e-003	0.0000	68.0348	68.0348	0.0206	0.0000	68.5490

Islais Creek Ground Improvements - San Francisco County, Annual

3.2 Trenching - 2020

Mitigated Construction Off-Site

Category	tons/yr										MT/yr					
	ROG	NOx	CO	SO2	Fugitive PM10	Exhaust PM10	PM10 Total	Fugitive PM2.5	Exhaust PM2.5	PM2.5 Total	Bio- CO2	NBio- CO2	Total CO2	CH4	N2O	CO2e
Hauling	0.0000	0.0000	0.0000	0.0000	0.0000	0.0000	0.0000	0.0000	0.0000	0.0000	0.0000	0.0000	0.0000	0.0000	0.0000	0.0000
Vendor	2.4000e-004	8.2600e-003	2.4400e-003	2.0000e-005	4.3000e-004	4.0000e-005	4.7000e-004	1.2000e-004	3.0000e-005	1.6000e-004	0.0000	1.8270	1.8270	2.4000e-004	0.0000	1.8330
Worker	1.8100e-003	1.2000e-003	0.0134	5.0000e-005	4.6900e-003	4.0000e-005	4.7300e-003	1.2500e-003	3.0000e-005	1.2800e-003	0.0000	4.4609	4.4609	1.0000e-004	0.0000	4.4634
Total	2.0500e-003	9.4600e-003	0.0158	7.0000e-005	5.1200e-003	8.0000e-005	5.2000e-003	1.3700e-003	6.0000e-005	1.4400e-003	0.0000	6.2879	6.2879	3.4000e-004	0.0000	6.2964

3.2 Trenching - 2021

Unmitigated Construction On-Site

Category	tons/yr										MT/yr					
	ROG	NOx	CO	SO2	Fugitive PM10	Exhaust PM10	PM10 Total	Fugitive PM2.5	Exhaust PM2.5	PM2.5 Total	Bio- CO2	NBio- CO2	Total CO2	CH4	N2O	CO2e
Off-Road	0.0146	0.1490	0.1119	3.0000e-004		6.4100e-003	6.4100e-003		6.0300e-003	6.0300e-003	0.0000	25.8098	25.8098	7.0000e-003	0.0000	25.9849
Total	0.0146	0.1490	0.1119	3.0000e-004		6.4100e-003	6.4100e-003		6.0300e-003	6.0300e-003	0.0000	25.8098	25.8098	7.0000e-003	0.0000	25.9849

Islais Creek Ground Improvements - San Francisco County, Annual

3.2 Trenching - 2021
Unmitigated Construction Off-Site

Category	tons/yr										MT/yr					
	ROG	NOx	CO	SO2	Fugitive PM10	Exhaust PM10	PM10 Total	Fugitive PM2.5	Exhaust PM2.5	PM2.5 Total	Bio- CO2	NBio- CO2	Total CO2	CH4	N2O	CO2e
Hauling	0.0000	0.0000	0.0000	0.0000	0.0000	0.0000	0.0000	0.0000	0.0000	0.0000	0.0000	0.0000	0.0000	0.0000	0.0000	0.0000
Vendor	7.0000e-005	2.5200e-003	7.7000e-004	1.0000e-005	1.4000e-004	1.0000e-005	1.5000e-004	1.0000e-005	1.0000e-005	5.0000e-005	0.0000	0.6012	0.6012	8.0000e-005	0.0000	0.6032
Worker	5.6000e-004	3.6000e-004	4.1200e-003	2.0000e-005	1.5600e-003	1.0000e-005	1.5800e-003	1.0000e-005	1.0000e-005	4.3000e-004	0.0000	1.4339	1.4339	3.0000e-005	0.0000	1.4346
Total	6.3000e-004	2.8800e-003	4.8900e-003	3.0000e-005	1.7000e-003	2.0000e-005	1.7300e-003	4.6000e-004	2.0000e-005	4.8000e-004	0.0000	2.0351	2.0351	1.1000e-004	0.0000	2.0378

Mitigated Construction On-Site

Category	tons/yr										MT/yr					
	ROG	NOx	CO	SO2	Fugitive PM10	Exhaust PM10	PM10 Total	Fugitive PM2.5	Exhaust PM2.5	PM2.5 Total	Bio- CO2	NBio- CO2	Total CO2	CH4	N2O	CO2e
Off-Road	3.1300e-003	0.0136	0.1302	3.0000e-004		4.2000e-004	4.2000e-004		4.2000e-004	4.2000e-004	0.0000	22.7011	22.7011	6.8500e-003	0.0000	22.8723
Total	3.1300e-003	0.0136	0.1302	3.0000e-004		4.2000e-004	4.2000e-004		4.2000e-004	4.2000e-004	0.0000	22.7011	22.7011	6.8500e-003	0.0000	22.8723

Islais Creek Ground Improvements - San Francisco County, Annual

3.4 Architectural Coating - 2021

Mitigated Construction Off-Site

Category	tons/yr											MT/yr					
	ROG	NOx	CO	SO2	Fugitive PM10	Exhaust PM10	PM10 Total	Fugitive PM2.5	Exhaust PM2.5	PM2.5 Total	Bio- CO2	NBio- CO2	Total CO2	CH4	N2O	CO2e	
Hauling	0.0000	0.0000	0.0000	0.0000	0.0000	0.0000	0.0000	0.0000	0.0000	0.0000	0.0000	0.0000	0.0000	0.0000	0.0000	0.0000	0.0000
Vendor	0.0000	0.0000	0.0000	0.0000	0.0000	0.0000	0.0000	0.0000	0.0000	0.0000	0.0000	0.0000	0.0000	0.0000	0.0000	0.0000	0.0000
Worker	0.0000	0.0000	0.0000	0.0000	0.0000	0.0000	0.0000	0.0000	0.0000	0.0000	0.0000	0.0000	0.0000	0.0000	0.0000	0.0000	0.0000
Total	0.0000	0.0000	0.0000	0.0000	0.0000	0.0000	0.0000	0.0000	0.0000	0.0000	0.0000	0.0000	0.0000	0.0000	0.0000	0.0000	0.0000

4.0 Operational Detail - Mobile

4.1 Mitigation Measures Mobile

Islais Creek Ground Improvements - San Francisco County, Annual

Category	tons/yr													MT/yr			
	ROG	NOx	CO	SO2	Fugitive PM10	Exhaust PM10	PM10 Total	Fugitive PM2.5	Exhaust PM2.5	PM2.5 Total	Bio- CO2	NBio- CO2	Total CO2	CH4	N2O	CO2e	
Mitigated	0.0000	0.0000	0.0000	0.0000	0.0000	0.0000	0.0000	0.0000	0.0000	0.0000	0.0000	0.0000	0.0000	0.0000	0.0000	0.0000	
Unmitigated	0.0000	0.0000	0.0000	0.0000	0.0000	0.0000	0.0000	0.0000	0.0000	0.0000	0.0000	0.0000	0.0000	0.0000	0.0000	0.0000	

4.2 Trip Summary Information

Land Use	Average Daily Trip Rate			Unmitigated		Mitigated	
	Weekday	Saturday	Sunday	Annual VMT	Annual VMT	Annual VMT	Annual VMT
User Defined Industrial	0.00	0.00	0.00				
Total	0.00	0.00	0.00				

4.3 Trip Type Information

Land Use	Miles						Trip %			Trip Purpose %		
	H-W or C-C	H-S or C-C	H-O or C-NW	H-W or C-W	H-S or C-C	H-O or C-NW	Primary	Diverted	Pass-by	Primary	Diverted	Pass-by
User Defined Industrial	9.50	7.30	7.30	0.00	0.00	0.00	0	0	0	0	0	0

4.4 Fleet Mix

Land Use	LDA	LDT1	LDT2	MDV	LHD1	LHD2	MHD	HHD	OBUS	UBUS	MCY	SBUS	MH
User Defined Industrial	0.606408	0.040118	0.191445	0.088323	0.014900	0.004926	0.028280	0.008891	0.004289	0.004272	0.006741	0.000931	0.000477

5.0 Energy Detail

Historical Energy Use: N

Islais Creek Ground Improvements - San Francisco County, Annual

5.2 Energy by Land Use - Natural Gas

Mitigated

Land Use	Natural Gas Use kBtu/yr	tons/yr										MT/yr						
		ROG	NOx	CO	SO2	Fugitive PM10	Exhaust PM10	PM10 Total	Fugitive PM2.5	Exhaust PM2.5	PM2.5 Total	Bio-CO2	NBio-CO2	Total CO2	CH4	N2O	CO2e	
User Defined Industrial	0	0.0000	0.0000	0.0000	0.0000	0.0000	0.0000	0.0000	0.0000	0.0000	0.0000	0.0000	0.0000	0.0000	0.0000	0.0000	0.0000	0.0000
Total		0.0000	0.0000	0.0000	0.0000	0.0000	0.0000	0.0000	0.0000	0.0000	0.0000	0.0000	0.0000	0.0000	0.0000	0.0000	0.0000	0.0000

5.3 Energy by Land Use - Electricity

Unmitigated

Land Use	Electricity Use kWh/yr	MT/yr				
		Total CO2	CH4	N2O	CO2e	
User Defined Industrial	0	0.0000	0.0000	0.0000	0.0000	0.0000
Total		0.0000	0.0000	0.0000	0.0000	0.0000

Islais Creek Ground Improvements - San Francisco County, Annual

5.3 Energy by Land Use - Electricity

Mitigated

Land Use	Electricity Use kWh/yr	Total CO2	CH4	N2O	CO2e
User Defined Industrial	0	0.0000	0.0000	0.0000	0.0000
Total		0.0000	0.0000	0.0000	0.0000

6.0 Area Detail

6.1 Mitigation Measures Area

Category	tons/yr																
	ROG	NOx	CO	SO2	Fugitive PM10	Exhaust PM10	PM10 Total	Fugitive PM2.5	Exhaust PM2.5	PM2.5 Total	Bio- CO2	NBio- CO2	Total CO2	CH4	N2O	CO2e	
Mitigated	0.0000	0.0000	1.0000e-005	0.0000	0.0000	0.0000	0.0000	0.0000	0.0000	0.0000	0.0000	2.0000e-005	2.0000e-005	0.0000	0.0000	0.0000	2.0000e-005
Unmitigated	0.0000	0.0000	1.0000e-005	0.0000	0.0000	0.0000	0.0000	0.0000	0.0000	0.0000	0.0000	2.0000e-005	2.0000e-005	0.0000	0.0000	0.0000	2.0000e-005

Islais Creek Ground Improvements - San Francisco County, Annual

6.2 Area by SubCategory

Unmitigated

SubCategory	tons/yr										MT/yr					
	ROG	NOx	CO	SO2	Fugitive PM10	Exhaust PM10	PM10 Total	Fugitive PM2.5	Exhaust PM2.5	PM2.5 Total	Bio- CO2	NBio- CO2	Total CO2	CH4	N2O	CO2e
Architectural Coating	0.0000					0.0000	0.0000	0.0000	0.0000	0.0000	0.0000	0.0000	0.0000	0.0000	0.0000	0.0000
Consumer Products	0.0000					0.0000	0.0000	0.0000	0.0000	0.0000	0.0000	0.0000	0.0000	0.0000	0.0000	0.0000
Landscaping	0.0000	0.0000	1.0000e-005	0.0000		0.0000	0.0000	0.0000	0.0000	0.0000	0.0000	2.0000e-005	2.0000e-005	0.0000	0.0000	2.0000e-005
Total	0.0000	0.0000	1.0000e-005	0.0000		0.0000	0.0000	0.0000	0.0000	0.0000	0.0000	2.0000e-005	2.0000e-005	0.0000	0.0000	2.0000e-005

Mitigated

SubCategory	tons/yr										MT/yr					
	ROG	NOx	CO	SO2	Fugitive PM10	Exhaust PM10	PM10 Total	Fugitive PM2.5	Exhaust PM2.5	PM2.5 Total	Bio- CO2	NBio- CO2	Total CO2	CH4	N2O	CO2e
Architectural Coating	0.0000					0.0000	0.0000	0.0000	0.0000	0.0000	0.0000	0.0000	0.0000	0.0000	0.0000	0.0000
Consumer Products	0.0000					0.0000	0.0000	0.0000	0.0000	0.0000	0.0000	0.0000	0.0000	0.0000	0.0000	0.0000
Landscaping	0.0000	0.0000	1.0000e-005	0.0000		0.0000	0.0000	0.0000	0.0000	0.0000	0.0000	2.0000e-005	2.0000e-005	0.0000	0.0000	2.0000e-005
Total	0.0000	0.0000	1.0000e-005	0.0000		0.0000	0.0000	0.0000	0.0000	0.0000	0.0000	2.0000e-005	2.0000e-005	0.0000	0.0000	2.0000e-005

7.0 Water Detail

7.1 Mitigation Measures Water

	Total CO2	CH4	N2O	CO2e
Category	MT/yr			
Mitigated	0.0000	0.0000	0.0000	0.0000
Unmitigated	0.0000	0.0000	0.0000	0.0000

7.2 Water by Land Use

Unmitigated

	Indoor/Outdoor Use	Total CO2	CH4	N2O	CO2e
Land Use	Mgal				
User Defined Industrial	0 / 0	0.0000	0.0000	0.0000	0.0000
Total		0.0000	0.0000	0.0000	0.0000

Islais Creek Ground Improvements - San Francisco County, Annual

7.2 Water by Land Use

Mitigated

Land Use	Indoor/Outdoor Use	Total CO2	CH4	N2O	CO2e
	Mgal	MT/yr			
User Defined Industrial	0 / 0	0.0000	0.0000	0.0000	0.0000
Total		0.0000	0.0000	0.0000	0.0000

8.0 Waste Detail

8.1 Mitigation Measures Waste

Category/Year

Category/Year	Total CO2	CH4	N2O	CO2e
	MT/yr			
Mitigated	0.0000	0.0000	0.0000	0.0000
Unmitigated	0.0000	0.0000	0.0000	0.0000

Islais Creek Ground Improvements - San Francisco County, Annual

8.2 Waste by Land Use

Unmitigated

Land Use	Waste Disposed tons	Total CO2				CO2e
		CH4	N2O	MT/yr		
User Defined Industrial	0	0.0000	0.0000	0.0000	0.0000	0.0000
Total		0.0000	0.0000	0.0000	0.0000	0.0000

Mitigated

Land Use	Waste Disposed tons	Total CO2				CO2e
		CH4	N2O	MT/yr		
User Defined Industrial	0	0.0000	0.0000	0.0000	0.0000	0.0000
Total		0.0000	0.0000	0.0000	0.0000	0.0000

9.0 Operational Offroad

Equipment Type	Number	Hours/Day	Days/Year	Horse Power	Load Factor	Fuel Type
----------------	--------	-----------	-----------	-------------	-------------	-----------

Islais Creek Ground Improvements - San Francisco County, Annual

10.0 Stationary Equipment

Fire Pumps and Emergency Generators

Equipment Type	Number	Hours/Day	Hours/Year	Horse Power	Load Factor	Fuel Type
----------------	--------	-----------	------------	-------------	-------------	-----------

Boilers

Equipment Type	Number	Heat Input/Day	Heat Input/Year	Boiler Rating	Fuel Type
----------------	--------	----------------	-----------------	---------------	-----------

User Defined Equipment

Equipment Type	Number
----------------	--------

11.0 Vegetation

DB-130 CalEEMod Runs

BCTD DB-130 - San Francisco County, Annual

BCTD DB-130
San Francisco County, Annual

1.0 Project Characteristics

1.1 Land Usage

Land Uses	Size	Metric	Lot Acreage	Floor Surface Area	Population
User Defined Industrial	1.00	User Defined Unit	0.31	0.00	0

1.2 Other Project Characteristics

Urbanization	Urban	Wind Speed (m/s)	4.6	Precipitation Freq (Days)	64
Climate Zone	5			Operational Year	2021

Utility Company Pacific Gas & Electric Company

CO2 Intensity (lb/MW/hr)	641.35	CH4 Intensity (lb/MW/hr)	0.029	N2O Intensity (lb/MW/hr)	0.006
---------------------------------	--------	---------------------------------	-------	---------------------------------	-------

1.3 User Entered Comments & Non-Default Data

BCTD DB-130 - San Francisco County, Annual

Project Characteristics -

Land Use - Project specific acreage based on 13,400 sq. ft.

Construction Phase - Project specific construction schedule.

Off-road Equipment - Project specific equipment.

Off-road Equipment - Project specific equipment.

Off-road Equipment - Project specific equipment.

Off-road Equipment - Project specific equipment.

Off-road Equipment - Project specific equipment.

Off-road Equipment - Project specific equipment.

Off-road Equipment - Project specific equipment.

Grading - Assumes approximately 2,325 CY of material export and 3,750 CY of material import.

Trips and VMT - Based on 10-13 workers per day per phase and approximately 1,455 CY of concrete placement (modeled as concrete truck trips). Haul truck capacity assumed to be 16 CY.

Construction Off-road Equipment Mitigation - Assumes fugitive dust control and Tier 2 with B20 fuel. Assumes generator is electric.

Table Name	Column Name	Default Value	New Value
tblConstEquipMitigation	FuelType	Diesel	Bio-diesel
tblConstEquipMitigation	FuelType	Diesel	Bio-diesel
tblConstEquipMitigation	FuelType	Diesel	Bio-diesel
tblConstEquipMitigation	FuelType	Diesel	Bio-diesel
tblConstEquipMitigation	FuelType	Diesel	Electrical
tblConstEquipMitigation	FuelType	Diesel	Bio-diesel
tblConstEquipMitigation	FuelType	Diesel	Bio-diesel
tblConstEquipMitigation	FuelType	Diesel	Bio-diesel
tblConstEquipMitigation	NumberOfEquipmentMitigated	0.00	7.00
tblConstEquipMitigation	NumberOfEquipmentMitigated	0.00	1.00
tblConstEquipMitigation	NumberOfEquipmentMitigated	0.00	4.00
tblConstEquipMitigation	NumberOfEquipmentMitigated	0.00	1.00

BCTD DB-130 - San Francisco County, Annual

tblConstEquipMitigation	NumberOfEquipmentMitigated	0.00	7.00
tblConstEquipMitigation	NumberOfEquipmentMitigated	0.00	6.00
tblConstEquipMitigation	NumberOfEquipmentMitigated	0.00	3.00
tblConstEquipMitigation	NumberOfEquipmentMitigated	0.00	4.00
tblConstEquipMitigation	Tier	No Change	Tier 2
tblConstEquipMitigation	Tier	No Change	Tier 2
tblConstEquipMitigation	Tier	No Change	Tier 2
tblConstEquipMitigation	Tier	No Change	Tier 2
tblConstEquipMitigation	Tier	No Change	Tier 2
tblConstEquipMitigation	Tier	No Change	Tier 2
tblConstEquipMitigation	Tier	No Change	Tier 2
tblConstructionPhase	NumDays	100.00	22.00
tblConstructionPhase	NumDays	2.00	32.00
tblConstructionPhase	NumDays	1.00	23.00
tblConstructionPhase	NumDays	100.00	39.00
tblConstructionPhase	NumDays	100.00	39.00
tblConstructionPhase	NumDays	2.00	22.00
tblConstructionPhase	PhaseEndDate	10/23/2020	9/15/2020
tblConstructionPhase	PhaseEndDate	6/3/2020	8/14/2020
tblConstructionPhase	PhaseEndDate	6/1/2020	7/1/2020
tblConstructionPhase	PhaseEndDate	3/12/2021	11/9/2020
tblConstructionPhase	PhaseEndDate	7/30/2021	1/1/2021
tblConstructionPhase	PhaseEndDate	6/5/2020	2/2/2021
tblConstructionPhase	PhaseEndDate	6/5/2020	3/1/2021
tblConstructionPhase	PhaseStartDate	6/6/2020	8/15/2020
tblConstructionPhase	PhaseStartDate	6/2/2020	7/2/2020
tblConstructionPhase	PhaseStartDate	10/24/2020	9/16/2020

BCTD DB-130 - San Francisco County, Annual

tblConstructionPhase	PhaseStartDate	3/13/2021	11/10/2020
tblConstructionPhase	PhaseStartDate	6/4/2020	1/2/2021
tblConstructionPhase	PhaseStartDate	6/6/2020	2/3/2021
tblGrading	AcresOfGrading	0.00	0.50
tblGrading	MaterialExported	0.00	2,325.00
tblGrading	MaterialImported	0.00	3,750.00
tblLandUse	LotAcreage	0.00	0.31
tblOffRoadEquipment	OffRoadEquipmentType		Excavators
tblOffRoadEquipment	OffRoadEquipmentType		Off-Highway Trucks
tblOffRoadEquipment	OffRoadEquipmentType		Plate Compactors
tblOffRoadEquipment	OffRoadEquipmentType		Generator Sets
tblOffRoadEquipment	OffRoadEquipmentType		Air Compressors
tblOffRoadEquipment	OffRoadEquipmentType		Bore/Drill Rigs
tblOffRoadEquipment	OffRoadEquipmentType		Cranes
tblOffRoadEquipment	OffRoadEquipmentType		Generator Sets
tblOffRoadEquipment	OffRoadEquipmentType		Air Compressors
tblOffRoadEquipment	OffRoadEquipmentType		Generator Sets
tblOffRoadEquipment	OffRoadEquipmentType		Air Compressors
tblOffRoadEquipment	OffRoadEquipmentType		Off-Highway Trucks
tblOffRoadEquipment	OffRoadEquipmentType		Plate Compactors
tblOffRoadEquipment	OffRoadEquipmentType		Generator Sets
tblOffRoadEquipment	OffRoadEquipmentType		Air Compressors
tblOffRoadEquipment	OffRoadEquipmentType		Plate Compactors
tblOffRoadEquipment	OffRoadEquipmentType		Generator Sets
tblOffRoadEquipment	OffRoadEquipmentType		Air Compressors
tblOffRoadEquipment	OffRoadEquipmentType		Off-Highway Trucks
tblOffRoadEquipment	OffRoadEquipmentType		Plate Compactors

BCTD DB-130 - San Francisco County, Annual

tbIOffRoadEquipment	PhaseName	2: Pile Driving
tbIOffRoadEquipment	PhaseName	3: Concrete Foundations
tbIOffRoadEquipment	PhaseName	3: Concrete Foundations
tbIOffRoadEquipment	PhaseName	4: Concrete Slabs
tbIOffRoadEquipment	PhaseName	4: Concrete Slabs
tbIOffRoadEquipment	PhaseName	4: Concrete Slabs
tbIOffRoadEquipment	PhaseName	4: Concrete Slabs
tbIOffRoadEquipment	PhaseName	5: Perimeter Wall
tbIOffRoadEquipment	PhaseName	5: Perimeter Wall
tbIOffRoadEquipment	PhaseName	5: Perimeter Wall
tbIOffRoadEquipment	PhaseName	6: Backfill and Grading
tbIOffRoadEquipment	PhaseName	6: Backfill and Grading
tbIOffRoadEquipment	PhaseName	6: Backfill and Grading
tbIOffRoadEquipment	PhaseName	6: Backfill and Grading
tbIOffRoadEquipment	PhaseName	7: Electrical Equipment/Gate Install
tbIOffRoadEquipment	PhaseName	7: Electrical Equipment/Gate Install
tbIOffRoadEquipment	PhaseName	7: Electrical Equipment/Gate Install
tbIOffRoadEquipment	PhaseName	7: Electrical Equipment/Gate Install
tbIOffRoadEquipment	UsageHours	8.00
tbIOffRoadEquipment	UsageHours	4.00
tbIOffRoadEquipment	UsageHours	6.00
tbIOffRoadEquipment	UsageHours	8.00
tbIOffRoadEquipment	UsageHours	1.00
tbIOffRoadEquipment	UsageHours	6.00
tbIOffRoadEquipment	UsageHours	8.00
tbIOffRoadEquipment	UsageHours	4.00
tbIOffRoadEquipment	UsageHours	4.00
tbIOffRoadEquipment	UsageHours	8.00

BCTD DB-130 - San Francisco County, Annual

tblOffRoadEquipment	UsageHours	6.00	0.00
tblOffRoadEquipment	UsageHours	6.00	0.00
tblOffRoadEquipment	UsageHours	1.00	0.00
tblOffRoadEquipment	UsageHours	6.00	8.00
tblTripsAndVMT	VendorTripNumber	0.00	5.00
tblTripsAndVMT	VendorTripNumber	0.00	5.00
tblTripsAndVMT	WorkerTripNumber	15.00	26.00
tblTripsAndVMT	WorkerTripNumber	10.00	20.00
tblTripsAndVMT	WorkerTripNumber	0.00	22.00
tblTripsAndVMT	WorkerTripNumber	0.00	26.00
tblTripsAndVMT	WorkerTripNumber	0.00	24.00
tblTripsAndVMT	WorkerTripNumber	13.00	24.00
tblTripsAndVMT	WorkerTripNumber	10.00	22.00

2.0 Emissions Summary

BCTD DB-130 - San Francisco County, Annual

2.1 Overall Construction
Unmitigated Construction

Year	tons/yr										MT/yr					
	ROG	NOx	CO	SO2	Fugitive PM10	Exhaust PM10	PM10 Total	Fugitive PM2.5	Exhaust PM2.5	PM2.5 Total	Bio- CO2	NBio- CO2	Total CO2	CH4	N2O	CO2e
2020	0.1194	1.1225	0.9322	2.1000e-003	0.0187	0.0534	0.0721	4.9500e-003	0.0513	0.0562	0.0000	185.7258	185.7258	0.0347	0.0000	186.5931
2021	0.0320	0.3352	0.2726	7.3000e-004	8.3400e-003	0.0130	0.0213	2.1900e-003	0.0124	0.0146	0.0000	67.0952	67.0952	0.0126	0.0000	67.4104
Maximum	0.1194	1.1225	0.9322	2.1000e-003	0.0187	0.0534	0.0721	4.9500e-003	0.0513	0.0562	0.0000	185.7258	185.7258	0.0347	0.0000	186.5931

Mitigated Construction

Year	tons/yr										MT/yr					
	ROG	NOx	CO	SO2	Fugitive PM10	Exhaust PM10	PM10 Total	Fugitive PM2.5	Exhaust PM2.5	PM2.5 Total	Bio- CO2	NBio- CO2	Total CO2	CH4	N2O	CO2e
2020	0.0389	1.1438	0.7262	2.1000e-003	0.0184	0.0284	0.0468	4.9000e-003	0.0284	0.0333	22.0360	120.1687	142.2047	0.0322	0.0000	143.0107
2021	0.0120	0.3731	0.2203	7.3000e-004	8.0300e-003	8.2100e-003	0.0163	2.1400e-003	8.2000e-003	0.0103	6.2137	49.0121	55.2258	0.0120	0.0000	55.5259
Maximum	0.0389	1.1438	0.7262	2.1000e-003	0.0184	0.0284	0.0468	4.9000e-003	0.0284	0.0333	22.0360	120.1687	142.2047	0.0322	0.0000	143.0107

Percent Reduction	tons/yr										MT/yr					
	ROG	NOx	CO	SO2	Fugitive PM10	Exhaust PM10	PM10 Total	Fugitive PM2.5	Exhaust PM2.5	PM2.5 Total	Bio- CO2	NBio- CO2	Total CO2	CH4	N2O	CO2e
	66.37	-4.06	21.43	0.00	2.37	44.78	32.49	1.40	42.54	38.39	0.00	33.08	21.91	6.47	0.00	21.84

BCTD DB-130 - San Francisco County, Annual

Quarter	Start Date	End Date	Maximum Unmitigated ROG + NOX (tons/quarter)	Maximum Mitigated ROG + NOX (tons/quarter)
1	6-1-2020	8-31-2020	0.5307	0.5262
2	9-1-2020	11-30-2020	0.5267	0.5084
3	12-1-2020	2-28-2021	0.5455	0.5290
4	3-1-2021	5-31-2021	0.0048	0.0042
		Highest	0.5455	0.5290

2.2 Overall Operational

Unmitigated Operational

Category	tons/yr										MT/yr					
	ROG	NOx	CO	SO2	Fugitive PM10	Exhaust PM10	PM10 Total	Fugitive PM2.5	Exhaust PM2.5	PM2.5 Total	Bio- CO2	NBio- CO2	Total CO2	CH4	N2O	CO2e
Area	0.0000	0.0000	1.0000e-005	0.0000	0.0000	0.0000	0.0000	0.0000	0.0000	0.0000	0.0000	2.0000e-005	2.0000e-005	0.0000	0.0000	2.0000e-005
Energy	0.0000	0.0000	0.0000	0.0000	0.0000	0.0000	0.0000	0.0000	0.0000	0.0000	0.0000	0.0000	0.0000	0.0000	0.0000	0.0000
Mobile	0.0000	0.0000	0.0000	0.0000	0.0000	0.0000	0.0000	0.0000	0.0000	0.0000	0.0000	0.0000	0.0000	0.0000	0.0000	0.0000
Waste																
Water																
Total	0.0000	0.0000	1.0000e-005	0.0000	0.0000	0.0000	0.0000	0.0000	0.0000	0.0000	0.0000	2.0000e-005	2.0000e-005	0.0000	0.0000	2.0000e-005

BCTD DB-130 - San Francisco County, Annual

2.2 Overall Operational

Mitigated Operational

Category	tons/yr											MT/yr					
	ROG	NOx	CO	SO2	Fugitive PM10	Exhaust PM10	PM10 Total	Fugitive PM2.5	Exhaust PM2.5	PM2.5 Total	Bio- CO2	NBio- CO2	Total CO2	CH4	N2O	CO2e	
Area	0.0000	0.0000	1.0000e-005	0.0000		0.0000	0.0000	0.0000	0.0000	0.0000	0.0000	2.0000e-005	2.0000e-005	0.0000	0.0000	0.0000	2.0000e-005
Energy	0.0000	0.0000	0.0000	0.0000		0.0000	0.0000	0.0000	0.0000	0.0000	0.0000	0.0000	0.0000	0.0000	0.0000	0.0000	0.0000
Mobile	0.0000	0.0000	0.0000	0.0000	0.0000	0.0000	0.0000	0.0000	0.0000	0.0000	0.0000	0.0000	0.0000	0.0000	0.0000	0.0000	0.0000
Waste						0.0000	0.0000	0.0000	0.0000	0.0000	0.0000	0.0000	0.0000	0.0000	0.0000	0.0000	0.0000
Water						0.0000	0.0000	0.0000	0.0000	0.0000	0.0000	0.0000	0.0000	0.0000	0.0000	0.0000	0.0000
Total	0.0000	0.0000	1.0000e-005	0.0000	0.0000	0.0000	0.0000	0.0000	0.0000	0.0000	0.0000	2.0000e-005	2.0000e-005	0.0000	0.0000	0.0000	2.0000e-005

Percent Reduction	tons/yr											MT/yr				
	ROG	NOx	CO	SO2	Fugitive PM10	Exhaust PM10	PM10 Total	Fugitive PM2.5	Exhaust PM2.5	PM2.5 Total	Bio- CO2	NBio- CO2	Total CO2	CH4	N2O	CO2e
0.00	0.00	0.00	0.00	0.00	0.00	0.00	0.00	0.00	0.00	0.00	0.00	0.00	0.00	0.00	0.00	0.00

3.0 Construction Detail

Construction Phase

BCTD DB-130 - San Francisco County, Annual

Phase Number	Phase Name	Phase Type	Start Date	End Date	Num Days Week	Num Days	Phase Description
1	1: Site Excavation	Site Preparation	6/1/2020	7/1/2020	5	23	
2	2: Pile Driving	Grading	7/2/2020	8/14/2020	5	32	
3	6: Backfill and Grading	Grading	1/2/2021	2/2/2021	5	22	
4	3: Concrete Foundations	Building Construction	8/15/2020	9/15/2020	5	22	
5	7: Electrical Equipment/Gate Install	Trenching	2/3/2021	3/1/2021	5	19	
6	4: Concrete Slabs	Building Construction	9/16/2020	11/9/2020	5	39	
7	5: Perimeter Wall	Building Construction	11/10/2020	1/1/2021	5	39	

Acres of Grading (Site Preparation Phase): 0

Acres of Grading (Grading Phase): 0

Acres of Paving: 0

Residential Indoor: 0; Residential Outdoor: 0; Non-Residential Indoor: 0; Non-Residential Outdoor: 0; Striped Parking Area: 0 (Architectural Coating – sqft)

OffRoad Equipment

Phase Name	Offroad Equipment Type	Amount	Usage Hours	Horse Power	Load Factor
6: Backfill and Grading	Concrete/Industrial Saws	0	0.00	81	0.73
4: Concrete Slabs	Cranes	0	0.00	231	0.29
5: Perimeter Wall	Cranes	1	8.00	231	0.29
2: Pile Driving	Concrete/Industrial Saws	0	0.00	81	0.73
3: Concrete Foundations	Cranes	1	8.00	231	0.29
3: Concrete Foundations	Forklifts	0	0.00	89	0.20
1: Site Excavation	Graders	0	0.00	187	0.41
4: Concrete Slabs	Forklifts	0	0.00	89	0.20
5: Perimeter Wall	Forklifts	0	0.00	89	0.20

BCTD DB-130 - San Francisco County, Annual

6: Backfill and Grading	Rubber Tired Dozers	0	0.00	247	0.40
2: Pile Driving	Rubber Tired Dozers	0	0.00	247	0.40
3: Concrete Foundations	Tractors/Loaders/Backhoes	1	8.00	97	0.37
4: Concrete Slabs	Tractors/Loaders/Backhoes	1	8.00	97	0.37
2: Pile Driving	Tractors/Loaders/Backhoes	0	0.00	97	0.37
5: Perimeter Wall	Tractors/Loaders/Backhoes	1	8.00	97	0.37
1: Site Excavation	Tractors/Loaders/Backhoes	1	8.00	97	0.37
6: Backfill and Grading	Tractors/Loaders/Backhoes	1	8.00	97	0.37
1: Site Excavation	Excavators	1	8.00	158	0.38
1: Site Excavation	Off-Highway Trucks	1	1.00	402	0.38
1: Site Excavation	Plate Compactors	1	2.00	8	0.43
1: Site Excavation	Generator Sets	1	8.00	84	0.74
1: Site Excavation	Air Compressors	1	8.00	78	0.48
2: Pile Driving	Bore/Drill Rigs	1	8.00	221	0.50
2: Pile Driving	Cranes	1	8.00	231	0.29
2: Pile Driving	Generator Sets	1	8.00	84	0.74
2: Pile Driving	Air Compressors	1	8.00	78	0.48
3: Concrete Foundations	Generator Sets	1	8.00	84	0.74
3: Concrete Foundations	Air Compressors	1	8.00	78	0.48
4: Concrete Slabs	Off-Highway Trucks	1	8.00	402	0.38
4: Concrete Slabs	Plate Compactors	1	8.00	8	0.43
4: Concrete Slabs	Generator Sets	1	8.00	84	0.74
4: Concrete Slabs	Air Compressors	1	8.00	78	0.48
5: Perimeter Wall	Plate Compactors	1	8.00	8	0.43
5: Perimeter Wall	Generator Sets	1	8.00	84	0.74
5: Perimeter Wall	Air Compressors	1	8.00	78	0.48
6: Backfill and Grading	Off-Highway Trucks	1	8.00	402	0.38

BCTD DB-130 - San Francisco County, Annual

6: Backfill and Grading	Plate Compactors	1	8.00	8	0.43
6: Backfill and Grading	Generator Sets	1	8.00	84	0.74
6: Backfill and Grading	Air Compressors	1	8.00	78	0.48
7: Electrical Equipment/Gate Install	Tractors/Loaders/Backhoes	1	8.00	97	0.37
7: Electrical Equipment/Gate Install	Cranes	1	8.00	231	0.29
7: Electrical Equipment/Gate Install	Generator Sets	1	8.00	84	0.74
7: Electrical Equipment/Gate Install	Air Compressors	1	8.00	78	0.48

Trips and VMT

Phase Name	Offroad Equipment Count	Worker Trip Number	Vendor Trip Number	Hauling Trip Number	Worker Trip Length	Vendor Trip Length	Hauling Trip Length	Worker Vehicle Class	Vendor Vehicle Class	Hauling Vehicle Class
4: Concrete Slabs	5	26.00	5.00	0.00	10.80	7.30	20.00	LD_Mix	HDT_Mix	HHDT
1: Site Excavation	6	26.00	0.00	291.00	10.80	7.30	20.00	LD_Mix	HDT_Mix	HHDT
2: Pile Driving	4	20.00	0.00	0.00	10.80	7.30	20.00	LD_Mix	HDT_Mix	HHDT
3: Concrete Foundations	4	22.00	0.00	0.00	10.80	7.30	20.00	LD_Mix	HDT_Mix	HHDT
5: Perimeter Wall	5	24.00	5.00	0.00	10.80	7.30	20.00	LD_Mix	HDT_Mix	HHDT
6: Backfill and Grading	5	24.00	0.00	469.00	10.80	7.30	20.00	LD_Mix	HDT_Mix	HHDT
7: Electrical Equipment/Gate Install	4	22.00	0.00	0.00	10.80	7.30	20.00	LD_Mix	HDT_Mix	HHDT

3.1 Mitigation Measures Construction

- Use Alternative Fuel for Construction Equipment
- Use Cleaner Engines for Construction Equipment
- Water Exposed Area

BCTD DB-130 - San Francisco County, Annual

3.2 1:Site Excavation - 2020
Unmitigated Construction On-Site

Category	tons/yr											MT/yr				
	ROG	NOx	CO	SO2	Fugitive PM10	Exhaust PM10	PM10 Total	Fugitive PM2.5	Exhaust PM2.5	PM2.5 Total	Bio- CO2	NBio- CO2	Total CO2	CH4	N2O	CO2e
Fugitive Dust					6.1000e-004	0.0000	6.1000e-004	8.0000e-005	0.0000	8.0000e-005	0.0000	0.0000	0.0000	0.0000	0.0000	0.0000
Off-Road	0.0146	0.1276	0.1406	2.4000e-004	7.1900e-003	7.1900e-003	6.9400e-003	6.9400e-003	6.9400e-003	6.9400e-003	0.0000	20.5276	20.5276	3.9200e-003	0.0000	20.6256
Total	0.0146	0.1276	0.1406	2.4000e-004	6.1000e-004	7.8000e-003	8.0000e-005	6.9400e-003	7.0200e-003	7.0200e-003	0.0000	20.5276	20.5276	3.9200e-003	0.0000	20.6256

Unmitigated Construction Off-Site

Category	tons/yr											MT/yr				
	ROG	NOx	CO	SO2	Fugitive PM10	Exhaust PM10	PM10 Total	Fugitive PM2.5	Exhaust PM2.5	PM2.5 Total	Bio- CO2	NBio- CO2	Total CO2	CH4	N2O	CO2e
Hauling	1.1600e-003	0.0507	0.0150	1.2000e-004	2.4400e-003	1.5000e-004	2.5900e-003	6.7000e-004	1.4000e-004	8.1000e-004	0.0000	12.9982	12.9982	2.3300e-003	0.0000	13.0564
Vendor	0.0000	0.0000	0.0000	0.0000	0.0000	0.0000	0.0000	0.0000	0.0000	0.0000	0.0000	0.0000	0.0000	0.0000	0.0000	0.0000
Worker	9.1000e-004	6.0000e-004	6.7200e-003	2.0000e-005	2.3600e-003	2.0000e-005	2.3800e-003	6.3000e-004	2.0000e-005	6.5000e-004	0.0000	2.2455	2.2455	5.0000e-005	0.0000	2.2467
Total	2.0700e-003	0.0513	0.0217	1.4000e-004	4.8000e-003	1.7000e-004	4.9700e-003	1.3000e-003	1.6000e-004	1.4600e-003	0.0000	15.2437	15.2437	2.3800e-003	0.0000	15.3031

BCTD DB-130 - San Francisco County, Annual

3.2 1:Site Excavation - 2020
Mitigated Construction On-Site

Category	tons/yr											MT/yr				
	ROG	NOx	CO	SO2	Fugitive PM10	Exhaust PM10	PM10 Total	Fugitive PM2.5	Exhaust PM2.5	PM2.5 Total	Bio- CO2	NBio- CO2	Total CO2	CH4	N2O	CO2e
Fugitive Dust					2.7000e-004	0.0000	2.7000e-004	4.0000e-005	0.0000	4.0000e-005	0.0000	0.0000	0.0000	0.0000	0.0000	0.0000
Off-Road	4.8900e-003	0.1388	0.0980	2.4000e-004	4.2700e-003	4.2700e-003	4.2700e-003	4.2700e-003	2.8055	11.2221	14.0277	3.5500e-003	0.0000	0.0000	0.0000	14.1165
Total	4.8900e-003	0.1388	0.0980	2.4000e-004	2.7000e-004	4.2700e-003	4.5400e-003	4.0000e-005	4.2700e-003	4.3100e-003	2.8055	11.2221	14.0277	3.5500e-003	0.0000	14.1165

Mitigated Construction Off-Site

Category	tons/yr											MT/yr				
	ROG	NOx	CO	SO2	Fugitive PM10	Exhaust PM10	PM10 Total	Fugitive PM2.5	Exhaust PM2.5	PM2.5 Total	Bio- CO2	NBio- CO2	Total CO2	CH4	N2O	CO2e
Hauling	1.1600e-003	0.0507	0.0150	1.2000e-004	2.4400e-003	1.5000e-004	2.5900e-003	6.7000e-004	1.4000e-004	8.1000e-004	0.0000	12.9982	12.9982	2.3300e-003	0.0000	13.0564
Vendor	0.0000	0.0000	0.0000	0.0000	0.0000	0.0000	0.0000	0.0000	0.0000	0.0000	0.0000	0.0000	0.0000	0.0000	0.0000	0.0000
Worker	9.1000e-004	6.0000e-004	6.7200e-003	2.0000e-005	2.3600e-003	2.0000e-005	2.3800e-003	6.3000e-004	2.0000e-005	6.5000e-004	0.0000	2.2455	2.2455	5.0000e-005	0.0000	2.2467
Total	2.0700e-003	0.0513	0.0217	1.4000e-004	4.8000e-003	1.7000e-004	4.9700e-003	1.3000e-003	1.6000e-004	1.4600e-003	0.0000	15.2437	15.2437	2.3800e-003	0.0000	15.3031

BCTD DB-130 - San Francisco County, Annual

3.3.2: Pile Driving - 2020
Unmitigated Construction On-Site

Category	tons/yr										MT/yr					
	ROG	NOx	CO	SO2	Fugitive PM10	Exhaust PM10	PM10 Total	Fugitive PM2.5	Exhaust PM2.5	PM2.5 Total	Bio- CO2	NBio- CO2	Total CO2	CH4	N2O	CO2e
Fugitive Dust					0.0000	0.0000	0.0000	0.0000	0.0000	0.0000	0.0000	0.0000	0.0000	0.0000	0.0000	0.0000
Off-Road	0.0233	0.2342	0.1655	4.1000e-004	0.0107	0.0107	0.0107	0.0103	0.0103	0.0103	0.0000	35.8069	35.8069	7.8300e-003	0.0000	36.0025
Total	0.0233	0.2342	0.1655	4.1000e-004	0.0000	0.0107	0.0107	0.0103	0.0103	0.0103	0.0000	35.8069	35.8069	7.8300e-003	0.0000	36.0025

Unmitigated Construction Off-Site

Category	tons/yr										MT/yr					
	ROG	NOx	CO	SO2	Fugitive PM10	Exhaust PM10	PM10 Total	Fugitive PM2.5	Exhaust PM2.5	PM2.5 Total	Bio- CO2	NBio- CO2	Total CO2	CH4	N2O	CO2e
Hauling	0.0000	0.0000	0.0000	0.0000	0.0000	0.0000	0.0000	0.0000	0.0000	0.0000	0.0000	0.0000	0.0000	0.0000	0.0000	0.0000
Vendor	0.0000	0.0000	0.0000	0.0000	0.0000	0.0000	0.0000	0.0000	0.0000	0.0000	0.0000	0.0000	0.0000	0.0000	0.0000	0.0000
Worker	9.7000e-004	6.5000e-004	7.1900e-003	3.0000e-005	2.5300e-003	2.0000e-005	2.5500e-003	6.7000e-004	2.0000e-005	6.9000e-004	0.0000	2.4032	2.4032	5.0000e-005	0.0000	2.4045
Total	9.7000e-004	6.5000e-004	7.1900e-003	3.0000e-005	2.5300e-003	2.0000e-005	2.5500e-003	6.7000e-004	2.0000e-005	6.9000e-004	0.0000	2.4032	2.4032	5.0000e-005	0.0000	2.4045

BCTD DB-130 - San Francisco County, Annual

3.3.2: Pile Driving - 2020
Mitigated Construction On-Site

Category	tons/yr											MT/yr				
	ROG	NOx	CO	SO2	Fugitive PM10	Exhaust PM10	PM10 Total	Fugitive PM2.5	Exhaust PM2.5	PM2.5 Total	Bio- CO2	NBio- CO2	Total CO2	CH4	N2O	CO2e
Fugitive Dust					0.0000	0.0000	0.0000	0.0000	0.0000	0.0000	0.0000	0.0000	0.0000	0.0000	0.0000	0.0000
Off-Road	6.6600e-003	0.2632	0.1507	4.1000e-004	5.7900e-003	5.7900e-003	5.7900e-003	5.7900e-003	5.7900e-003	5.7900e-003	5.3527	21.4108	26.7635	7.3200e-003	0.0000	26.9464
Total	6.6600e-003	0.2632	0.1507	4.1000e-004	0.0000	5.7900e-003	5.7900e-003	0.0000	5.7900e-003	5.7900e-003	5.3527	21.4108	26.7635	7.3200e-003	0.0000	26.9464

Mitigated Construction Off-Site

Category	tons/yr											MT/yr				
	ROG	NOx	CO	SO2	Fugitive PM10	Exhaust PM10	PM10 Total	Fugitive PM2.5	Exhaust PM2.5	PM2.5 Total	Bio- CO2	NBio- CO2	Total CO2	CH4	N2O	CO2e
Hauling	0.0000	0.0000	0.0000	0.0000	0.0000	0.0000	0.0000	0.0000	0.0000	0.0000	0.0000	0.0000	0.0000	0.0000	0.0000	0.0000
Vendor	0.0000	0.0000	0.0000	0.0000	0.0000	0.0000	0.0000	0.0000	0.0000	0.0000	0.0000	0.0000	0.0000	0.0000	0.0000	0.0000
Worker	9.7000e-004	6.5000e-004	7.1900e-003	3.0000e-005	2.5300e-003	2.0000e-005	2.5500e-003	6.7000e-004	2.0000e-005	6.9000e-004	0.0000	2.4032	2.4032	5.0000e-005	0.0000	2.4045
Total	9.7000e-004	6.5000e-004	7.1900e-003	3.0000e-005	2.5300e-003	2.0000e-005	2.5500e-003	6.7000e-004	2.0000e-005	6.9000e-004	0.0000	2.4032	2.4032	5.0000e-005	0.0000	2.4045

BCTD DB-130 - San Francisco County, Annual

3.4 6: Backfill and Grading - 2021

Unmitigated Construction On-Site

Category	tons/yr											MT/yr				
	ROG	NOx	CO	SO2	Fugitive PM10	Exhaust PM10	PM10 Total	Fugitive PM2.5	Exhaust PM2.5	PM2.5 Total	Bio- CO2	NBio- CO2	Total CO2	CH4	N2O	CO2e
Fugitive Dust					5.5000e-004	0.0000	5.5000e-004	8.0000e-005	0.0000	8.0000e-005	0.0000	0.0000	0.0000	0.0000	0.0000	0.0000
Off-Road	0.0163	0.1387	0.1340	3.0000e-004	6.6900e-003	6.6900e-003	6.6900e-003	6.4200e-003	6.4200e-003	6.4200e-003	0.0000	26.0672	26.0672	5.7100e-003	0.0000	26.2099
Total	0.0163	0.1387	0.1340	3.0000e-004	5.5000e-004	6.6900e-003	7.2400e-003	8.0000e-005	6.4200e-003	6.5000e-003	0.0000	26.0672	26.0672	5.7100e-003	0.0000	26.2099

Unmitigated Construction Off-Site

Category	tons/yr											MT/yr				
	ROG	NOx	CO	SO2	Fugitive PM10	Exhaust PM10	PM10 Total	Fugitive PM2.5	Exhaust PM2.5	PM2.5 Total	Bio- CO2	NBio- CO2	Total CO2	CH4	N2O	CO2e
Hauling	1.7800e-003	0.0757	0.0248	1.9000e-004	3.9300e-003	2.2000e-004	4.1500e-003	1.0800e-003	2.1000e-004	1.2900e-003	0.0000	20.5768	20.5768	3.7700e-003	0.0000	20.6712
Vendor	0.0000	0.0000	0.0000	0.0000	0.0000	0.0000	0.0000	0.0000	0.0000	0.0000	0.0000	0.0000	0.0000	0.0000	0.0000	0.0000
Worker	7.5000e-004	4.8000e-004	5.4900e-003	2.0000e-005	2.0900e-003	2.0000e-005	2.1000e-003	5.5000e-004	1.0000e-005	5.7000e-004	0.0000	1.9118	1.9118	4.0000e-005	0.0000	1.9128
Total	2.5300e-003	0.0762	0.0303	2.1000e-004	6.0200e-003	2.4000e-004	6.2500e-003	1.6300e-003	2.2000e-004	1.8600e-003	0.0000	22.4886	22.4886	3.8100e-003	0.0000	22.5840

BCTD DB-130 - San Francisco County, Annual

3.4 6: Backfill and Grading - 2021

Mitigated Construction On-Site

Category	tons/yr										MT/yr					
	ROG	NOx	CO	SO2	Fugitive PM10	Exhaust PM10	PM10 Total	Fugitive PM2.5	Exhaust PM2.5	PM2.5 Total	Bio- CO2	NBio- CO2	Total CO2	CH4	N2O	CO2e
Fugitive Dust					2.5000e-004	0.0000	2.5000e-004	4.0000e-005	0.0000	4.0000e-005	0.0000	0.0000	0.0000	0.0000	0.0000	0.0000
Off-Road	5.3900e-003	0.1835	0.1154	3.0000e-004	4.8000e-003	4.8000e-003	4.8000e-003	4.8000e-003	4.8000e-003	4.8000e-003	3.9700	15.8800	19.8499	5.3900e-003	0.0000	19.9847
Total	5.3900e-003	0.1835	0.1154	3.0000e-004	2.5000e-004	4.8000e-003	5.0500e-003	4.8000e-003	4.8000e-003	4.8400e-003	3.9700	15.8800	19.8499	5.3900e-003	0.0000	19.9847

Mitigated Construction Off-Site

Category	tons/yr										MT/yr					
	ROG	NOx	CO	SO2	Fugitive PM10	Exhaust PM10	PM10 Total	Fugitive PM2.5	Exhaust PM2.5	PM2.5 Total	Bio- CO2	NBio- CO2	Total CO2	CH4	N2O	CO2e
Hauling	1.7800e-003	0.0757	0.0248	1.9000e-004	3.9300e-003	2.2000e-004	4.1500e-003	1.0800e-003	2.1000e-004	1.2900e-003	0.0000	20.5768	20.5768	3.7700e-003	0.0000	20.6712
Vendor	0.0000	0.0000	0.0000	0.0000	0.0000	0.0000	0.0000	0.0000	0.0000	0.0000	0.0000	0.0000	0.0000	0.0000	0.0000	0.0000
Worker	7.5000e-004	4.8000e-004	5.4900e-003	2.0000e-005	2.0900e-003	2.0000e-005	2.1000e-003	5.5000e-004	1.0000e-005	5.7000e-004	0.0000	1.9118	1.9118	4.0000e-005	0.0000	1.9128
Total	2.5300e-003	0.0762	0.0303	2.1000e-004	6.0200e-003	2.4000e-004	6.2500e-003	1.6300e-003	2.2000e-004	1.8600e-003	0.0000	22.4886	22.4886	3.8100e-003	0.0000	22.5840

BCTD DB-130 - San Francisco County, Annual

3.5.3: Concrete Foundations - 2020

Unmitigated Construction On-Site

Category	tons/yr											MT/yr				
	ROG	NOx	CO	SO2	Fugitive PM10	Exhaust PM10	PM10 Total	Fugitive PM2.5	Exhaust PM2.5	PM2.5 Total	Bio- CO2	NBio- CO2	Total CO2	CH4	N2O	CO2e
Off-Road	0.0152	0.1454	0.1160	2.1000e-004	7.6900e-003	7.6900e-003	7.6900e-003	7.3800e-003	7.3800e-003	7.3800e-003	0.0000	18.5396	18.5396	3.4100e-003	0.0000	18.6250
Total	0.0152	0.1454	0.1160	2.1000e-004	7.6900e-003	7.6900e-003	7.6900e-003	7.3800e-003	7.3800e-003	7.3800e-003	0.0000	18.5396	18.5396	3.4100e-003	0.0000	18.6250

Unmitigated Construction Off-Site

Category	tons/yr											MT/yr				
	ROG	NOx	CO	SO2	Fugitive PM10	Exhaust PM10	PM10 Total	Fugitive PM2.5	Exhaust PM2.5	PM2.5 Total	Bio- CO2	NBio- CO2	Total CO2	CH4	N2O	CO2e
Hauling	0.0000	0.0000	0.0000	0.0000	0.0000	0.0000	0.0000	0.0000	0.0000	0.0000	0.0000	0.0000	0.0000	0.0000	0.0000	0.0000
Vendor	0.0000	0.0000	0.0000	0.0000	0.0000	0.0000	0.0000	0.0000	0.0000	0.0000	0.0000	0.0000	0.0000	0.0000	0.0000	0.0000
Worker	7.4000e-004	4.9000e-004	5.4400e-003	2.0000e-005	1.9100e-003	1.0000e-005	1.9300e-003	5.1000e-004	1.0000e-005	5.2000e-004	0.0000	1.8174	1.8174	4.0000e-005	0.0000	1.8184
Total	7.4000e-004	4.9000e-004	5.4400e-003	2.0000e-005	1.9100e-003	1.0000e-005	1.9300e-003	5.1000e-004	1.0000e-005	5.2000e-004	0.0000	1.8174	1.8174	4.0000e-005	0.0000	1.8184

BCTD DB-130 - San Francisco County, Annual

3.5 3: Concrete Foundations - 2020
Mitigated Construction On-Site

Category	tons/yr											MT/yr				
	ROG	NOx	CO	SO2	Fugitive PM10	Exhaust PM10	PM10 Total	Fugitive PM2.5	Exhaust PM2.5	PM2.5 Total	Bio- CO2	NBio- CO2	Total CO2	CH4	N2O	CO2e
Off-Road	3.8100e-003	0.1239	0.0769	2.1000e-004	3.4800e-003	3.4800e-003	3.4800e-003	3.4800e-003	3.4800e-003	3.4800e-003	2.4645	9.8579	12.3223	3.0600e-003	0.0000	12.3989
Total	3.8100e-003	0.1239	0.0769	2.1000e-004	3.4800e-003	3.4800e-003	3.4800e-003	3.4800e-003	3.4800e-003	3.4800e-003	2.4645	9.8579	12.3223	3.0600e-003	0.0000	12.3989

Mitigated Construction Off-Site

Category	tons/yr											MT/yr				
	ROG	NOx	CO	SO2	Fugitive PM10	Exhaust PM10	PM10 Total	Fugitive PM2.5	Exhaust PM2.5	PM2.5 Total	Bio- CO2	NBio- CO2	Total CO2	CH4	N2O	CO2e
Hauling	0.0000	0.0000	0.0000	0.0000	0.0000	0.0000	0.0000	0.0000	0.0000	0.0000	0.0000	0.0000	0.0000	0.0000	0.0000	0.0000
Vendor	0.0000	0.0000	0.0000	0.0000	0.0000	0.0000	0.0000	0.0000	0.0000	0.0000	0.0000	0.0000	0.0000	0.0000	0.0000	0.0000
Worker	7.4000e-004	4.9000e-004	5.4400e-003	2.0000e-005	1.9100e-003	1.0000e-005	1.9300e-003	5.1000e-004	1.0000e-005	5.2000e-004	0.0000	1.8174	1.8174	4.0000e-005	0.0000	1.8184
Total	7.4000e-004	4.9000e-004	5.4400e-003	2.0000e-005	1.9100e-003	1.0000e-005	1.9300e-003	5.1000e-004	1.0000e-005	5.2000e-004	0.0000	1.8174	1.8174	4.0000e-005	0.0000	1.8184

BCTD DB-130 - San Francisco County, Annual

3.6.7: Electrical Equipment/Gate Install - 2021

Unmitigated Construction On-Site

Category	tons/yr											MT/yr				
	ROG	NOx	CO	SO2	Fugitive PM10	Exhaust PM10	PM10 Total	Fugitive PM2.5	Exhaust PM2.5	PM2.5 Total	Bio- CO2	NBio- CO2	Total CO2	CH4	N2O	CO2e
Off-Road	0.0119	0.1135	0.0983	1.8000e-004	5.7200e-003	5.7200e-003	5.7200e-003	5.4800e-003	5.4800e-003	5.4800e-003	0.0000	16.0122	16.0122	2.8900e-003	0.0000	16.0845
Total	0.0119	0.1135	0.0983	1.8000e-004	5.7200e-003	5.7200e-003	5.7200e-003	5.4800e-003	5.4800e-003	5.4800e-003	0.0000	16.0122	16.0122	2.8900e-003	0.0000	16.0845

Unmitigated Construction Off-Site

Category	tons/yr											MT/yr				
	ROG	NOx	CO	SO2	Fugitive PM10	Exhaust PM10	PM10 Total	Fugitive PM2.5	Exhaust PM2.5	PM2.5 Total	Bio- CO2	NBio- CO2	Total CO2	CH4	N2O	CO2e
Hauling	0.0000	0.0000	0.0000	0.0000	0.0000	0.0000	0.0000	0.0000	0.0000	0.0000	0.0000	0.0000	0.0000	0.0000	0.0000	0.0000
Vendor	0.0000	0.0000	0.0000	0.0000	0.0000	0.0000	0.0000	0.0000	0.0000	0.0000	0.0000	0.0000	0.0000	0.0000	0.0000	0.0000
Worker	5.9000e-004	3.8000e-004	4.3400e-003	2.0000e-005	1.6500e-003	1.0000e-005	1.6600e-003	4.4000e-004	1.0000e-005	4.5000e-004	0.0000	1.5135	1.5135	3.0000e-005	0.0000	1.5143
Total	5.9000e-004	3.8000e-004	4.3400e-003	2.0000e-005	1.6500e-003	1.0000e-005	1.6600e-003	4.4000e-004	1.0000e-005	4.5000e-004	0.0000	1.5135	1.5135	3.0000e-005	0.0000	1.5143

BCTD DB-130 - San Francisco County, Annual

3.6 7: Electrical Equipment/Gate Install - 2021

Mitigated Construction On-Site

Category	tons/yr											MT/yr				
	ROG	NOx	CO	SO2	Fugitive PM10	Exhaust PM10	PM10 Total	Fugitive PM2.5	Exhaust PM2.5	PM2.5 Total	Bio- CO2	NBio- CO2	Total CO2	CH4	N2O	CO2e
Off-Road	3.2900e-003	0.1070	0.0664	1.8000e-004		3.0100e-003	3.0100e-003		3.0100e-003	3.0100e-003	2.1285	8.5142	10.6427	2.6200e-003	0.0000	10.7082
Total	3.2900e-003	0.1070	0.0664	1.8000e-004		3.0100e-003	3.0100e-003		3.0100e-003	3.0100e-003	2.1285	8.5142	10.6427	2.6200e-003	0.0000	10.7082

Mitigated Construction Off-Site

Category	tons/yr											MT/yr				
	ROG	NOx	CO	SO2	Fugitive PM10	Exhaust PM10	PM10 Total	Fugitive PM2.5	Exhaust PM2.5	PM2.5 Total	Bio- CO2	NBio- CO2	Total CO2	CH4	N2O	CO2e
Hauling	0.0000	0.0000	0.0000	0.0000	0.0000	0.0000	0.0000	0.0000	0.0000	0.0000	0.0000	0.0000	0.0000	0.0000	0.0000	0.0000
Vendor	0.0000	0.0000	0.0000	0.0000	0.0000	0.0000	0.0000	0.0000	0.0000	0.0000	0.0000	0.0000	0.0000	0.0000	0.0000	0.0000
Worker	5.9000e-004	3.8000e-004	4.3400e-003	2.0000e-005	1.6500e-003	1.0000e-005	1.6600e-003	4.4000e-004	1.0000e-005	4.5000e-004	0.0000	1.5135	1.5135	3.0000e-005	0.0000	1.5143
Total	5.9000e-004	3.8000e-004	4.3400e-003	2.0000e-005	1.6500e-003	1.0000e-005	1.6600e-003	4.4000e-004	1.0000e-005	4.5000e-004	0.0000	1.5135	1.5135	3.0000e-005	0.0000	1.5143

BCTD DB-130 - San Francisco County, Annual

3.7 4: Concrete Slabs - 2020
Unmitigated Construction On-Site

Category	tons/yr											MT/yr				
	ROG	NOx	CO	SO2	Fugitive PM10	Exhaust PM10	PM10 Total	Fugitive PM2.5	Exhaust PM2.5	PM2.5 Total	Bio- CO2	NBio- CO2	Total CO2	CH4	N2O	CO2e
Off-Road	0.0319	0.2809	0.2427	5.3000e-004	0.0140	0.0140	0.0140	0.0134	0.0134	0.0134	0.0000	46.2095	46.2095	0.0102	0.0000	46.4654
Total	0.0319	0.2809	0.2427	5.3000e-004	0.0140	0.0140	0.0140	0.0134	0.0134	0.0134	0.0000	46.2095	46.2095	0.0102	0.0000	46.4654

Unmitigated Construction Off-Site

Category	tons/yr											MT/yr				
	ROG	NOx	CO	SO2	Fugitive PM10	Exhaust PM10	PM10 Total	Fugitive PM2.5	Exhaust PM2.5	PM2.5 Total	Bio- CO2	NBio- CO2	Total CO2	CH4	N2O	CO2e
Hauling	0.0000	0.0000	0.0000	0.0000	0.0000	0.0000	0.0000	0.0000	0.0000	0.0000	0.0000	0.0000	0.0000	0.0000	0.0000	0.0000
Vendor	3.6000e-004	0.0122	3.6100e-003	3.0000e-005	6.4000e-004	5.0000e-005	6.9000e-004	1.8000e-004	5.0000e-005	2.4000e-004	0.0000	2.6989	2.6989	3.6000e-004	0.0000	2.7079
Worker	1.5400e-003	1.0300e-003	0.0114	4.0000e-005	4.0100e-003	3.0000e-005	4.0400e-003	1.0700e-003	3.0000e-005	1.0900e-003	0.0000	3.8075	3.8075	8.0000e-005	0.0000	3.8096
Total	1.9000e-003	0.0132	0.0150	7.0000e-005	4.6500e-003	8.0000e-005	4.7300e-003	1.2500e-003	8.0000e-005	1.3300e-003	0.0000	6.5064	6.5064	4.4000e-004	0.0000	6.5175

BCTD DB-130 - San Francisco County, Annual

3.7 4: Concrete Slabs - 2020
Mitigated Construction On-Site

Category	tons/yr										MT/yr					
	ROG	NOx	CO	SO2	Fugitive PM10	Exhaust PM10	PM10 Total	Fugitive PM2.5	Exhaust PM2.5	PM2.5 Total	Bio- CO2	NBio- CO2	Total CO2	CH4	N2O	CO2e
Off-Road	9.5500e-003	0.3253	0.2046	5.3000e-004	8.5100e-003	8.5100e-003	8.5100e-003	8.5100e-003	8.5100e-003	8.5100e-003	7.0376	28.1504	35.1879	9.6100e-003	0.0000	35.4283
Total	9.5500e-003	0.3253	0.2046	5.3000e-004	8.5100e-003	8.5100e-003	8.5100e-003	8.5100e-003	8.5100e-003	8.5100e-003	7.0376	28.1504	35.1879	9.6100e-003	0.0000	35.4283

Mitigated Construction Off-Site

Category	tons/yr										MT/yr					
	ROG	NOx	CO	SO2	Fugitive PM10	Exhaust PM10	PM10 Total	Fugitive PM2.5	Exhaust PM2.5	PM2.5 Total	Bio- CO2	NBio- CO2	Total CO2	CH4	N2O	CO2e
Hauling	0.0000	0.0000	0.0000	0.0000	0.0000	0.0000	0.0000	0.0000	0.0000	0.0000	0.0000	0.0000	0.0000	0.0000	0.0000	0.0000
Vendor	3.6000e-004	0.0122	3.6100e-003	3.0000e-005	6.4000e-004	5.0000e-005	6.9000e-004	1.8000e-004	5.0000e-005	2.4000e-004	0.0000	2.6989	2.6989	3.6000e-004	0.0000	2.7079
Worker	1.5400e-003	1.0300e-003	0.0114	4.0000e-005	4.0100e-003	3.0000e-005	4.0400e-003	1.0700e-003	3.0000e-005	1.0900e-003	0.0000	3.8075	3.8075	8.0000e-005	0.0000	3.8096
Total	1.9000e-003	0.0132	0.0150	7.0000e-005	4.6500e-003	8.0000e-005	4.7300e-003	1.2500e-003	8.0000e-005	1.3300e-003	0.0000	6.5064	6.5064	4.4000e-004	0.0000	6.5175

BCTD DB-130 - San Francisco County, Annual

3.8.5: Perimeter Wall - 2020
Unmitigated Construction On-Site

Category	tons/yr											MT/yr				
	ROG	NOx	CO	SO2	Fugitive PM10	Exhaust PM10	PM10 Total	Fugitive PM2.5	Exhaust PM2.5	PM2.5 Total	Bio- CO2	NBio- CO2	Total CO2	CH4	N2O	CO2e
Off-Road	0.0271	0.2560	0.2043	3.8000e-004		0.0135	0.0135		0.0129	0.0129	0.0000	32.6173	32.6173	5.9600e-003	0.0000	32.7662
Total	0.0271	0.2560	0.2043	3.8000e-004		0.0135	0.0135		0.0129	0.0129	0.0000	32.6173	32.6173	5.9600e-003	0.0000	32.7662

Unmitigated Construction Off-Site

Category	tons/yr											MT/yr				
	ROG	NOx	CO	SO2	Fugitive PM10	Exhaust PM10	PM10 Total	Fugitive PM2.5	Exhaust PM2.5	PM2.5 Total	Bio- CO2	NBio- CO2	Total CO2	CH4	N2O	CO2e
Hauling	0.0000	0.0000	0.0000	0.0000	0.0000	0.0000	0.0000	0.0000	0.0000	0.0000	0.0000	0.0000	0.0000	0.0000	0.0000	0.0000
Vendor	3.5000e-004	0.0119	3.5100e-003	3.0000e-005	6.2000e-004	5.0000e-005	6.7000e-004	1.8000e-004	5.0000e-005	2.3000e-004	0.0000	2.6297	2.6297	3.5000e-004	0.0000	2.6385
Worker	1.3900e-003	9.2000e-004	0.0103	4.0000e-005	3.6000e-003	3.0000e-005	3.6300e-003	9.6000e-004	3.0000e-005	9.8000e-004	0.0000	3.4245	3.4245	8.0000e-005	0.0000	3.4264
Total	1.7400e-003	0.0128	0.0138	7.0000e-005	4.2200e-003	8.0000e-005	4.3000e-003	1.1400e-003	8.0000e-005	1.2100e-003	0.0000	6.0542	6.0542	4.3000e-004	0.0000	6.0649

BCTD DB-130 - San Francisco County, Annual

3.8.5: Perimeter Wall - 2020

Mitigated Construction On-Site

Category	tons/yr										MT/yr					
	ROG	NOx	CO	SO2	Fugitive PM10	Exhaust PM10	PM10 Total	Fugitive PM2.5	Exhaust PM2.5	PM2.5 Total	Bio- CO2	NBio- CO2	Total CO2	CH4	N2O	CO2e
Off-Road	6.5800e-003	0.2141	0.1329	3.8000e-004	6.0200e-003	6.0200e-003	6.0200e-003	6.0200e-003	6.0200e-003	6.0200e-003	4.3757	17.5026	21.8783	5.3500e-003	0.0000	22.0122
Total	6.5800e-003	0.2141	0.1329	3.8000e-004	6.0200e-003	6.0200e-003	6.0200e-003	6.0200e-003	6.0200e-003	6.0200e-003	4.3757	17.5026	21.8783	5.3500e-003	0.0000	22.0122

Mitigated Construction Off-Site

Category	tons/yr										MT/yr					
	ROG	NOx	CO	SO2	Fugitive PM10	Exhaust PM10	PM10 Total	Fugitive PM2.5	Exhaust PM2.5	PM2.5 Total	Bio- CO2	NBio- CO2	Total CO2	CH4	N2O	CO2e
Hauling	0.0000	0.0000	0.0000	0.0000	0.0000	0.0000	0.0000	0.0000	0.0000	0.0000	0.0000	0.0000	0.0000	0.0000	0.0000	0.0000
Vendor	3.5000e-004	0.0119	3.5100e-003	3.0000e-005	6.2000e-004	5.0000e-005	6.7000e-004	1.8000e-004	5.0000e-005	2.3000e-004	0.0000	2.6297	2.6297	3.5000e-004	0.0000	2.6385
Worker	1.3900e-003	9.2000e-004	0.0103	4.0000e-005	3.6000e-003	3.0000e-005	3.6300e-003	9.6000e-004	3.0000e-005	9.8000e-004	0.0000	3.4245	3.4245	8.0000e-005	0.0000	3.4264
Total	1.7400e-003	0.0128	0.0138	7.0000e-005	4.2200e-003	8.0000e-005	4.3000e-003	1.1400e-003	8.0000e-005	1.2100e-003	0.0000	6.0542	6.0542	4.3000e-004	0.0000	6.0649

BCTD DB-130 - San Francisco County, Annual

3.8.5: Perimeter Wall - 2021
Unmitigated Construction On-Site

Category	tons/yr											MT/yr				
	ROG	NOx	CO	SO2	Fugitive PM10	Exhaust PM10	PM10 Total	Fugitive PM2.5	Exhaust PM2.5	PM2.5 Total	Bio- CO2	NBio- CO2	Total CO2	CH4	N2O	CO2e
Off-Road	6.4000e-004	6.1000e-003	5.2800e-003	1.0000e-005	3.1000e-004	3.1000e-004	3.1000e-004	2.9000e-004	2.9000e-004	2.9000e-004	0.0000	0.8584	0.8584	1.5000e-004	0.0000	0.8622
Total	6.4000e-004	6.1000e-003	5.2800e-003	1.0000e-005	3.1000e-004	3.1000e-004	3.1000e-004	2.9000e-004	2.9000e-004	2.9000e-004	0.0000	0.8584	0.8584	1.5000e-004	0.0000	0.8622

Unmitigated Construction Off-Site

Category	tons/yr											MT/yr				
	ROG	NOx	CO	SO2	Fugitive PM10	Exhaust PM10	PM10 Total	Fugitive PM2.5	Exhaust PM2.5	PM2.5 Total	Bio- CO2	NBio- CO2	Total CO2	CH4	N2O	CO2e
Hauling	0.0000	0.0000	0.0000	0.0000	0.0000	0.0000	0.0000	0.0000	0.0000	0.0000	0.0000	0.0000	0.0000	0.0000	0.0000	0.0000
Vendor	1.0000e-005	2.9000e-004	9.0000e-005	0.0000	2.0000e-005	0.0000	2.0000e-005	0.0000	0.0000	1.0000e-005	0.0000	0.0683	0.0683	1.0000e-005	0.0000	0.0686
Worker	3.0000e-005	2.0000e-005	2.5000e-004	0.0000	9.0000e-005	0.0000	1.0000e-004	0.0000	0.0000	3.0000e-005	0.0000	0.0869	0.0869	0.0000	0.0000	0.0870
Total	4.0000e-005	3.1000e-004	3.4000e-004	0.0000	1.1000e-004	0.0000	1.2000e-004	3.0000e-005	0.0000	4.0000e-005	0.0000	0.1552	0.1552	1.0000e-005	0.0000	0.1555

BCTD DB-130 - San Francisco County, Annual

3.8 5: Perimeter Wall - 2021

Mitigated Construction On-Site

Category	tons/yr											MT/yr				
	ROG	NOx	CO	SO2	Fugitive PM10	Exhaust PM10	PM10 Total	Fugitive PM2.5	Exhaust PM2.5	PM2.5 Total	Bio- CO2	NBio- CO2	Total CO2	CH4	N2O	CO2e
Off-Road	1.7000e-004	5.6300e-003	3.5000e-003	1.0000e-005	1.6000e-004	1.6000e-004	1.6000e-004	1.6000e-004	1.6000e-004	1.6000e-004	0.1152	0.4606	0.5758	1.4000e-004	0.0000	0.5793
Total	1.7000e-004	5.6300e-003	3.5000e-003	1.0000e-005	1.6000e-004	1.6000e-004	1.6000e-004	1.6000e-004	1.6000e-004	1.6000e-004	0.1152	0.4606	0.5758	1.4000e-004	0.0000	0.5793

Mitigated Construction Off-Site

Category	tons/yr											MT/yr				
	ROG	NOx	CO	SO2	Fugitive PM10	Exhaust PM10	PM10 Total	Fugitive PM2.5	Exhaust PM2.5	PM2.5 Total	Bio- CO2	NBio- CO2	Total CO2	CH4	N2O	CO2e
Hauling	0.0000	0.0000	0.0000	0.0000	0.0000	0.0000	0.0000	0.0000	0.0000	0.0000	0.0000	0.0000	0.0000	0.0000	0.0000	0.0000
Vendor	1.0000e-005	2.9000e-004	9.0000e-005	0.0000	2.0000e-005	0.0000	2.0000e-005	0.0000	0.0000	1.0000e-005	0.0000	0.0683	0.0683	1.0000e-005	0.0000	0.0686
Worker	3.0000e-005	2.0000e-005	2.5000e-004	0.0000	9.0000e-005	0.0000	1.0000e-004	3.0000e-005	0.0000	3.0000e-005	0.0000	0.0869	0.0869	0.0000	0.0000	0.0870
Total	4.0000e-005	3.1000e-004	3.4000e-004	0.0000	1.1000e-004	0.0000	1.2000e-004	3.0000e-005	0.0000	4.0000e-005	0.0000	0.1552	0.1552	1.0000e-005	0.0000	0.1555

4.0 Operational Detail - Mobile

BCTD DB-130 - San Francisco County, Annual

4.1 Mitigation Measures Mobile

Category	tons/yr										MT/yr					
	ROG	NOx	CO	SO2	Fugitive PM10	Exhaust PM10	PM10 Total	Fugitive PM2.5	Exhaust PM2.5	PM2.5 Total	Bio- CO2	NBio- CO2	Total CO2	CH4	N2O	CO2e
Mitigated	0.0000	0.0000	0.0000	0.0000	0.0000	0.0000	0.0000	0.0000	0.0000	0.0000	0.0000	0.0000	0.0000	0.0000	0.0000	0.0000
Unmitigated	0.0000	0.0000	0.0000	0.0000	0.0000	0.0000	0.0000	0.0000	0.0000	0.0000	0.0000	0.0000	0.0000	0.0000	0.0000	0.0000

4.2 Trip Summary Information

Land Use	Average Daily Trip Rate			Unmitigated Annual VMT	Mitigated Annual VMT
	Weekday	Saturday	Sunday		
User Defined Industrial	0.00	0.00	0.00		
Total	0.00	0.00	0.00		

4.3 Trip Type Information

Land Use	Miles				Trip %				Trip Purpose %			
	H-W or C-W	H-S or C-C	H-O or C-NW	H-W or C-W	H-S or C-C	H-O or C-NW	Primary	Diverted	Pass-by	Primary	Diverted	Pass-by
User Defined Industrial	9.50	7.30	7.30	0.00	0.00	0.00	0.00	0.00	0.00	0.00	0.00	0.00

4.4 Fleet Mix

Land Use	LDA	LDT1	LDT2	MDV	LHD1	LHD2	MHD	HHD	OBUS	UBUS	MCY	SBUS	MH
User Defined Industrial	0.606408	0.040118	0.191445	0.088323	0.014900	0.004926	0.028280	0.008891	0.004289	0.004272	0.006741	0.000931	0.000477

5.3 Energy by Land Use - Electricity

Unmitigated

Land Use	Electricity Use	Total CO2	CH4	N2O	CO2e
	kWh/yr	MT/yr			
User Defined Industrial	0	0.0000	0.0000	0.0000	0.0000
Total		0.0000	0.0000	0.0000	0.0000

Mitigated

Land Use	Electricity Use	Total CO2	CH4	N2O	CO2e
	kWh/yr	MT/yr			
User Defined Industrial	0	0.0000	0.0000	0.0000	0.0000
Total		0.0000	0.0000	0.0000	0.0000

6.0 Area Detail

6.1 Mitigation Measures Area

BCTD DB-130 - San Francisco County, Annual

Category	ROG	NOx	CO	SO2	Fugitive PM10	Exhaust PM10	PM10 Total	Fugitive PM2.5	Exhaust PM2.5	PM2.5 Total	Bio- CO2	NBio- CO2	Total CO2	CH4	N2O	CO2e	
tons/yr																	
MT/yr																	
Mitigated	0.0000	0.0000	1.0000e-005	0.0000	0.0000	0.0000	0.0000	0.0000	0.0000	0.0000	0.0000	2.0000e-005	2.0000e-005	0.0000	0.0000	0.0000	2.0000e-005
Unmitigated	0.0000	0.0000	1.0000e-005	0.0000	0.0000	0.0000	0.0000	0.0000	0.0000	0.0000	0.0000	2.0000e-005	2.0000e-005	0.0000	0.0000	0.0000	2.0000e-005

6.2 Area by SubCategory

Unmitigated

SubCategory	ROG	NOx	CO	SO2	Fugitive PM10	Exhaust PM10	PM10 Total	Fugitive PM2.5	Exhaust PM2.5	PM2.5 Total	Bio- CO2	NBio- CO2	Total CO2	CH4	N2O	CO2e	
tons/yr																	
MT/yr																	
Architectural Coating	0.0000					0.0000	0.0000		0.0000	0.0000	0.0000	0.0000	0.0000	0.0000	0.0000	0.0000	0.0000
Consumer Products	0.0000					0.0000	0.0000		0.0000	0.0000	0.0000	0.0000	0.0000	0.0000	0.0000	0.0000	0.0000
Landscaping	0.0000	0.0000	1.0000e-005	0.0000		0.0000	0.0000		0.0000	0.0000	0.0000	2.0000e-005	2.0000e-005	0.0000	0.0000	0.0000	2.0000e-005
Total	0.0000	0.0000	1.0000e-005	0.0000		0.0000	0.0000		0.0000	0.0000	0.0000	2.0000e-005	2.0000e-005	0.0000	0.0000	0.0000	2.0000e-005

BCTD DB-130 - San Francisco County, Annual

6.2 Area by SubCategory

Mitigated

SubCategory	tons/yr											MT/yr				
	ROG	NOx	CO	SO2	Fugitive PM10	Exhaust PM10	PM10 Total	Fugitive PM2.5	Exhaust PM2.5	PM2.5 Total	Bio- CO2	NBio- CO2	Total CO2	CH4	N2O	CO2e
Architectural Coating	0.0000					0.0000	0.0000	0.0000	0.0000	0.0000	0.0000	0.0000	0.0000	0.0000	0.0000	0.0000
Consumer Products	0.0000					0.0000	0.0000	0.0000	0.0000	0.0000	0.0000	0.0000	0.0000	0.0000	0.0000	0.0000
Landscaping	0.0000	0.0000	1.0000e-005	0.0000		0.0000	0.0000	0.0000	0.0000	0.0000	0.0000	2.0000e-005	2.0000e-005	0.0000	0.0000	2.0000e-005
Total	0.0000	0.0000	1.0000e-005	0.0000		0.0000	0.0000	0.0000	0.0000	0.0000	0.0000	2.0000e-005	2.0000e-005	0.0000	0.0000	2.0000e-005

7.0 Water Detail

7.1 Mitigation Measures Water

BCTD DB-130 - San Francisco County, Annual

	Total CO2	CH4	N2O	CO2e
Category	MT/yr			
Mitigated	0.0000	0.0000	0.0000	0.0000
Unmitigated	0.0000	0.0000	0.0000	0.0000

7.2 Water by Land Use

Unmitigated

	Indoor/Outdoor Use	Total CO2	CH4	N2O	CO2e
Land Use	Mgal	MT/yr			
User Defined Industrial	0 / 0	0.0000	0.0000	0.0000	0.0000
Total		0.0000	0.0000	0.0000	0.0000

BCTD DB-130 - San Francisco County, Annual

7.2 Water by Land Use

Mitigated

Land Use	Indoor/Outdoor Use	Total CO2	CH4	N2O	CO2e
	Mgal	MT/yr			
User Defined Industrial	0 / 0	0.0000	0.0000	0.0000	0.0000
Total		0.0000	0.0000	0.0000	0.0000

8.0 Waste Detail

8.1 Mitigation Measures Waste

Category/Year

Category/Year	Total CO2	CH4	N2O	CO2e
	MT/yr			
Mitigated	0.0000	0.0000	0.0000	0.0000
Unmitigated	0.0000	0.0000	0.0000	0.0000

BCTD DB-130 - San Francisco County, Annual

8.2 Waste by Land Use

Unmitigated

Land Use	Waste Disposed tons	Total CO2				CO2e
		CH4	N2O	MT/yr		
User Defined Industrial	0	0.0000	0.0000	0.0000	0.0000	0.0000
Total		0.0000	0.0000	0.0000	0.0000	0.0000

Mitigated

Land Use	Waste Disposed tons	Total CO2				CO2e
		CH4	N2O	MT/yr		
User Defined Industrial	0	0.0000	0.0000	0.0000	0.0000	0.0000
Total		0.0000	0.0000	0.0000	0.0000	0.0000

9.0 Operational Offroad

Equipment Type	Number	Hours/Day	Days/Year	Horse Power	Load Factor	Fuel Type
----------------	--------	-----------	-----------	-------------	-------------	-----------

BCTD DB-130 - San Francisco County, Annual

10.0 Stationary Equipment

Fire Pumps and Emergency Generators

Equipment Type	Number	Hours/Day	Hours/Year	Horse Power	Load Factor	Fuel Type
----------------	--------	-----------	------------	-------------	-------------	-----------

Boilers

Equipment Type	Number	Heat Input/Day	Heat Input/Year	Boiler Rating	Fuel Type
----------------	--------	----------------	-----------------	---------------	-----------

User Defined Equipment

Equipment Type	Number
----------------	--------

11.0 Vegetation

BCTD DB-130 - San Francisco County, Annual

BCTD DB-130
San Francisco County, Annual

1.0 Project Characteristics

1.1 Land Usage

Land Uses	Size	Metric	Lot Acreage	Floor Surface Area	Population
User Defined Industrial	1.00	User Defined Unit	0.31	0.00	0

1.2 Other Project Characteristics

Urbanization	Urban	Wind Speed (m/s)	4.6	Precipitation Freq (Days)	64
Climate Zone	5			Operational Year	2021

Utility Company Pacific Gas & Electric Company

CO2 Intensity (lb/MW/hr)	641.35	CH4 Intensity (lb/MW/hr)	0.029	N2O Intensity (lb/MW/hr)	0.006
---------------------------------	--------	---------------------------------	-------	---------------------------------	-------

1.3 User Entered Comments & Non-Default Data

BCTD DB-130 - San Francisco County, Annual

Project Characteristics -

Land Use - Project specific acreage based on 13,400 sq. ft.

Construction Phase - Project specific construction schedule.

Off-road Equipment - Project specific equipment.

Off-road Equipment - Project specific equipment.

Off-road Equipment - Project specific equipment.

Off-road Equipment - Project specific equipment.

Off-road Equipment - Project specific equipment.

Off-road Equipment - Project specific equipment.

Off-road Equipment - Project specific equipment.

Grading - Assumes approximately 2,325 CY of material export and 3,750 CY of material import.

Trips and VMT - Based on 10-13 workers per day per phase and approximately 1,455 CY of concrete placement (modeled as concrete truck trips). Haul truck capacity assumed to be 16 CY.

Construction Off-road Equipment Mitigation - Assumes fugitive dust control and Tier 2, Level 3 DPF. Assumes generator is electric.

Table Name	Column Name	Default Value	New Value
tblConstEquipMitigation	DPF	No Change	Level 3
tblConstEquipMitigation	DPF	No Change	Level 3
tblConstEquipMitigation	DPF	No Change	Level 3
tblConstEquipMitigation	DPF	No Change	Level 3
tblConstEquipMitigation	DPF	No Change	Level 3
tblConstEquipMitigation	DPF	No Change	Level 3
tblConstEquipMitigation	DPF	No Change	Level 3
tblConstEquipMitigation	FuelType	Diesel	Electrical
tblConstEquipMitigation	NumberOfEquipmentMitigated	0.00	7.00
tblConstEquipMitigation	NumberOfEquipmentMitigated	0.00	1.00
tblConstEquipMitigation	NumberOfEquipmentMitigated	0.00	4.00
tblConstEquipMitigation	NumberOfEquipmentMitigated	0.00	1.00

BCTD DB-130 - San Francisco County, Annual

tblConstEquipMitigation	NumberOfEquipmentMitigated	0.00	7.00
tblConstEquipMitigation	NumberOfEquipmentMitigated	0.00	6.00
tblConstEquipMitigation	NumberOfEquipmentMitigated	0.00	3.00
tblConstEquipMitigation	NumberOfEquipmentMitigated	0.00	4.00
tblConstEquipMitigation	Tier	No Change	Tier 2
tblConstEquipMitigation	Tier	No Change	Tier 2
tblConstEquipMitigation	Tier	No Change	Tier 2
tblConstEquipMitigation	Tier	No Change	Tier 2
tblConstEquipMitigation	Tier	No Change	Tier 2
tblConstEquipMitigation	Tier	No Change	Tier 2
tblConstEquipMitigation	Tier	No Change	Tier 2
tblConstructionPhase	NumDays	100.00	22.00
tblConstructionPhase	NumDays	2.00	32.00
tblConstructionPhase	NumDays	1.00	23.00
tblConstructionPhase	NumDays	100.00	39.00
tblConstructionPhase	NumDays	100.00	39.00
tblConstructionPhase	NumDays	2.00	22.00
tblConstructionPhase	PhaseEndDate	10/23/2020	9/15/2020
tblConstructionPhase	PhaseEndDate	6/3/2020	8/14/2020
tblConstructionPhase	PhaseEndDate	6/1/2020	7/1/2020
tblConstructionPhase	PhaseEndDate	3/12/2021	11/9/2020
tblConstructionPhase	PhaseEndDate	7/30/2021	1/1/2021
tblConstructionPhase	PhaseEndDate	6/5/2020	2/2/2021
tblConstructionPhase	PhaseEndDate	6/5/2020	3/1/2021
tblConstructionPhase	PhaseStartDate	6/6/2020	8/15/2020
tblConstructionPhase	PhaseStartDate	6/2/2020	7/2/2020
tblConstructionPhase	PhaseStartDate	10/24/2020	9/16/2020

BCTD DB-130 - San Francisco County, Annual

tblConstructionPhase	PhaseStartDate	3/13/2021	11/10/2020
tblConstructionPhase	PhaseStartDate	6/4/2020	1/2/2021
tblConstructionPhase	PhaseStartDate	6/6/2020	2/3/2021
tblGrading	AcresOfGrading	0.00	0.50
tblGrading	MaterialExported	0.00	2,325.00
tblGrading	MaterialImported	0.00	3,750.00
tblLandUse	LotAcreage	0.00	0.31
tblOffRoadEquipment	OffRoadEquipmentType		Excavators
tblOffRoadEquipment	OffRoadEquipmentType		Off-Highway Trucks
tblOffRoadEquipment	OffRoadEquipmentType		Plate Compactors
tblOffRoadEquipment	OffRoadEquipmentType		Generator Sets
tblOffRoadEquipment	OffRoadEquipmentType		Air Compressors
tblOffRoadEquipment	OffRoadEquipmentType		Bore/Drill Rigs
tblOffRoadEquipment	OffRoadEquipmentType		Cranes
tblOffRoadEquipment	OffRoadEquipmentType		Generator Sets
tblOffRoadEquipment	OffRoadEquipmentType		Air Compressors
tblOffRoadEquipment	OffRoadEquipmentType		Generator Sets
tblOffRoadEquipment	OffRoadEquipmentType		Air Compressors
tblOffRoadEquipment	OffRoadEquipmentType		Off-Highway Trucks
tblOffRoadEquipment	OffRoadEquipmentType		Plate Compactors
tblOffRoadEquipment	OffRoadEquipmentType		Generator Sets
tblOffRoadEquipment	OffRoadEquipmentType		Air Compressors
tblOffRoadEquipment	OffRoadEquipmentType		Plate Compactors
tblOffRoadEquipment	OffRoadEquipmentType		Generator Sets
tblOffRoadEquipment	OffRoadEquipmentType		Air Compressors
tblOffRoadEquipment	OffRoadEquipmentType		Off-Highway Trucks
tblOffRoadEquipment	OffRoadEquipmentType		Plate Compactors

BCTD DB-130 - San Francisco County, Annual

tbIOffRoadEquipment	PhaseName	2: Pile Driving	
tbIOffRoadEquipment	PhaseName	3: Concrete Foundations	
tbIOffRoadEquipment	PhaseName	3: Concrete Foundations	
tbIOffRoadEquipment	PhaseName	4: Concrete Slabs	
tbIOffRoadEquipment	PhaseName	4: Concrete Slabs	
tbIOffRoadEquipment	PhaseName	4: Concrete Slabs	
tbIOffRoadEquipment	PhaseName	4: Concrete Slabs	
tbIOffRoadEquipment	PhaseName	5: Perimeter Wall	
tbIOffRoadEquipment	PhaseName	5: Perimeter Wall	
tbIOffRoadEquipment	PhaseName	5: Perimeter Wall	
tbIOffRoadEquipment	PhaseName	6: Backfill and Grading	
tbIOffRoadEquipment	PhaseName	6: Backfill and Grading	
tbIOffRoadEquipment	PhaseName	6: Backfill and Grading	
tbIOffRoadEquipment	PhaseName	6: Backfill and Grading	
tbIOffRoadEquipment	PhaseName	7: Electrical Equipment/Gate Install	
tbIOffRoadEquipment	PhaseName	7: Electrical Equipment/Gate Install	
tbIOffRoadEquipment	PhaseName	7: Electrical Equipment/Gate Install	
tbIOffRoadEquipment	PhaseName	7: Electrical Equipment/Gate Install	
tbIOffRoadEquipment	UsageHours	8.00	0.00
tbIOffRoadEquipment	UsageHours	4.00	0.00
tbIOffRoadEquipment	UsageHours	4.00	8.00
tbIOffRoadEquipment	UsageHours	8.00	0.00
tbIOffRoadEquipment	UsageHours	4.00	8.00
tbIOffRoadEquipment	UsageHours	6.00	0.00
tbIOffRoadEquipment	UsageHours	8.00	0.00
tbIOffRoadEquipment	UsageHours	6.00	0.00
tbIOffRoadEquipment	UsageHours	6.00	0.00

BCTD DB-130 - San Francisco County, Annual

tblOffRoadEquipment	UsageHours	1.00	0.00
tblOffRoadEquipment	UsageHours	1.00	0.00
tblOffRoadEquipment	UsageHours	6.00	0.00
tblOffRoadEquipment	UsageHours	6.00	8.00
tblTripsAndVMT	VendorTripNumber	0.00	5.00
tblTripsAndVMT	VendorTripNumber	0.00	5.00
tblTripsAndVMT	WorkerTripNumber	15.00	26.00
tblTripsAndVMT	WorkerTripNumber	10.00	20.00
tblTripsAndVMT	WorkerTripNumber	0.00	22.00
tblTripsAndVMT	WorkerTripNumber	0.00	26.00
tblTripsAndVMT	WorkerTripNumber	0.00	24.00
tblTripsAndVMT	WorkerTripNumber	13.00	24.00
tblTripsAndVMT	WorkerTripNumber	10.00	22.00

2.0 Emissions Summary

BCTD DB-130 - San Francisco County, Annual

2.1 Overall Construction
Unmitigated Construction

Year	tons/yr											MT/yr				
	ROG	NOx	CO	SO2	Fugitive PM10	Exhaust PM10	PM10 Total	Fugitive PM2.5	Exhaust PM2.5	PM2.5 Total	Bio- CO2	NBio- CO2	Total CO2	CH4	N2O	CO2e
2020	0.1194	1.1225	0.9322	2.1000e-003	0.0187	0.0534	0.0721	4.9500e-003	0.0513	0.0562	0.0000	185.7258	185.7258	0.0347	0.0000	186.5931
2021	0.0320	0.3352	0.2726	7.3000e-004	8.3400e-003	0.0130	0.0213	2.1900e-003	0.0124	0.0146	0.0000	67.0952	67.0952	0.0126	0.0000	67.4104
Maximum	0.1194	1.1225	0.9322	2.1000e-003	0.0187	0.0534	0.0721	4.9500e-003	0.0513	0.0562	0.0000	185.7258	185.7258	0.0347	0.0000	186.5931

Mitigated Construction

Year	tons/yr											MT/yr				
	ROG	NOx	CO	SO2	Fugitive PM10	Exhaust PM10	PM10 Total	Fugitive PM2.5	Exhaust PM2.5	PM2.5 Total	Bio- CO2	NBio- CO2	Total CO2	CH4	N2O	CO2e
2020	0.0473	1.1229	0.8082	2.1000e-003	0.0184	5.0500e-003	0.0234	4.9000e-003	5.0300e-003	9.9300e-003	0.0000	142.2047	142.2047	0.0322	0.0000	143.0107
2021	0.0144	0.3673	0.2432	7.3000e-004	8.0300e-003	1.5800e-003	9.6100e-003	2.1400e-003	1.5600e-003	3.7100e-003	0.0000	55.2258	55.2258	0.0120	0.0000	55.5259
Maximum	0.0473	1.1229	0.8082	2.1000e-003	0.0184	5.0500e-003	0.0234	4.9000e-003	5.0300e-003	9.9300e-003	0.0000	142.2047	142.2047	0.0322	0.0000	143.0107

ROG	NOx	CO	SO2	Fugitive PM10	Exhaust PM10	PM10 Total	Fugitive PM2.5	Exhaust PM2.5	PM2.5 Total	Bio- CO2	NBio- CO2	Total CO2	CH4	N2O	CO2e
Percent Reduction	59.24	-2.23	12.73	0.00	2.37	64.62	1.40	89.66	80.75	0.00	21.91	21.91	6.47	0.00	21.84

BCTD DB-130 - San Francisco County, Annual

Quarter	Start Date	End Date	Maximum Unmitigated ROG + NOX (tons/quarter)	Maximum Mitigated ROG + NOX (tons/quarter)
1	6-1-2020	8-31-2020	0.5307	0.5207
2	9-1-2020	11-30-2020	0.5267	0.5029
3	12-1-2020	2-28-2021	0.5455	0.5241
4	3-1-2021	5-31-2021	0.0048	0.0041
		Highest	0.5455	0.5241

2.2 Overall Operational

Unmitigated Operational

Category	tons/yr										MT/yr					
	ROG	NOx	CO	SO2	Fugitive PM10	Exhaust PM10	PM10 Total	Fugitive PM2.5	Exhaust PM2.5	PM2.5 Total	Bio- CO2	NBio- CO2	Total CO2	CH4	N2O	CO2e
Area	0.0000	0.0000	1.0000e-005	0.0000	0.0000	0.0000	0.0000	0.0000	0.0000	0.0000	0.0000	2.0000e-005	2.0000e-005	0.0000	0.0000	2.0000e-005
Energy	0.0000	0.0000	0.0000	0.0000	0.0000	0.0000	0.0000	0.0000	0.0000	0.0000	0.0000	0.0000	0.0000	0.0000	0.0000	0.0000
Mobile	0.0000	0.0000	0.0000	0.0000	0.0000	0.0000	0.0000	0.0000	0.0000	0.0000	0.0000	0.0000	0.0000	0.0000	0.0000	0.0000
Waste																
Water																
Total	0.0000	0.0000	1.0000e-005	0.0000	0.0000	0.0000	0.0000	0.0000	0.0000	0.0000	0.0000	2.0000e-005	2.0000e-005	0.0000	0.0000	2.0000e-005

BCTD DB-130 - San Francisco County, Annual

2.2 Overall Operational

Mitigated Operational

Category	tons/yr											MT/yr				
	ROG	NOx	CO	SO2	Fugitive PM10	Exhaust PM10	PM10 Total	Fugitive PM2.5	Exhaust PM2.5	PM2.5 Total	Bio- CO2	NBio- CO2	Total CO2	CH4	N2O	CO2e
Area	0.0000	0.0000	1.0000e-005	0.0000		0.0000	0.0000	0.0000	0.0000	0.0000	0.0000	2.0000e-005	2.0000e-005	0.0000	0.0000	2.0000e-005
Energy	0.0000	0.0000	0.0000	0.0000		0.0000	0.0000	0.0000	0.0000	0.0000	0.0000	0.0000	0.0000	0.0000	0.0000	0.0000
Mobile	0.0000	0.0000	0.0000	0.0000	0.0000	0.0000	0.0000	0.0000	0.0000	0.0000	0.0000	0.0000	0.0000	0.0000	0.0000	0.0000
Waste						0.0000	0.0000	0.0000	0.0000	0.0000	0.0000	0.0000	0.0000	0.0000	0.0000	0.0000
Water						0.0000	0.0000	0.0000	0.0000	0.0000	0.0000	0.0000	0.0000	0.0000	0.0000	0.0000
Total	0.0000	0.0000	1.0000e-005	0.0000	0.0000	0.0000	0.0000	0.0000	0.0000	0.0000	0.0000	2.0000e-005	2.0000e-005	0.0000	0.0000	2.0000e-005

Percent Reduction	tons/yr											MT/yr				
	ROG	NOx	CO	SO2	Fugitive PM10	Exhaust PM10	PM10 Total	Fugitive PM2.5	Exhaust PM2.5	PM2.5 Total	Bio- CO2	NBio- CO2	Total CO2	CH4	N2O	CO2e
0.00	0.00	0.00	0.00	0.00	0.00	0.00	0.00	0.00	0.00	0.00	0.00	0.00	0.00	0.00	0.00	0.00

3.0 Construction Detail

Construction Phase

BCTD DB-130 - San Francisco County, Annual

Phase Number	Phase Name	Phase Type	Start Date	End Date	Num Days Week	Num Days	Phase Description
1	1: Site Excavation	Site Preparation	6/1/2020	7/1/2020	5	23	
2	2: Pile Driving	Grading	7/2/2020	8/14/2020	5	32	
3	6: Backfill and Grading	Grading	1/2/2021	2/2/2021	5	22	
4	3: Concrete Foundations	Building Construction	8/15/2020	9/15/2020	5	22	
5	7: Electrical Equipment/Gate Install	Trenching	2/3/2021	3/1/2021	5	19	
6	4: Concrete Slabs	Building Construction	9/16/2020	11/9/2020	5	39	
7	5: Perimeter Wall	Building Construction	11/10/2020	1/1/2021	5	39	

Acres of Grading (Site Preparation Phase): 0

Acres of Grading (Grading Phase): 0

Acres of Paving: 0

Residential Indoor: 0; Residential Outdoor: 0; Non-Residential Indoor: 0; Non-Residential Outdoor: 0; Striped Parking Area: 0 (Architectural Coating – sqft)

OffRoad Equipment

Phase Name	Offroad Equipment Type	Amount	Usage Hours	Horse Power	Load Factor
6: Backfill and Grading	Concrete/Industrial Saws	0	0.00	81	0.73
4: Concrete Slabs	Cranes	0	0.00	231	0.29
5: Perimeter Wall	Cranes	1	8.00	231	0.29
2: Pile Driving	Concrete/Industrial Saws	0	0.00	81	0.73
3: Concrete Foundations	Cranes	1	8.00	231	0.29
3: Concrete Foundations	Forklifts	0	0.00	89	0.20
1: Site Excavation	Graders	0	0.00	187	0.41
4: Concrete Slabs	Forklifts	0	0.00	89	0.20
5: Perimeter Wall	Forklifts	0	0.00	89	0.20

BCTD DB-130 - San Francisco County, Annual

6: Backfill and Grading	Rubber Tired Dozers	0	0.00	247	0.40
2: Pile Driving	Rubber Tired Dozers	0	0.00	247	0.40
3: Concrete Foundations	Tractors/Loaders/Backhoes	1	8.00	97	0.37
4: Concrete Slabs	Tractors/Loaders/Backhoes	1	8.00	97	0.37
2: Pile Driving	Tractors/Loaders/Backhoes	0	0.00	97	0.37
5: Perimeter Wall	Tractors/Loaders/Backhoes	1	8.00	97	0.37
1: Site Excavation	Tractors/Loaders/Backhoes	1	8.00	97	0.37
6: Backfill and Grading	Tractors/Loaders/Backhoes	1	8.00	97	0.37
1: Site Excavation	Excavators	1	8.00	158	0.38
1: Site Excavation	Off-Highway Trucks	1	1.00	402	0.38
1: Site Excavation	Plate Compactors	1	2.00	8	0.43
1: Site Excavation	Generator Sets	1	8.00	84	0.74
1: Site Excavation	Air Compressors	1	8.00	78	0.48
2: Pile Driving	Bore/Drill Rigs	1	8.00	221	0.50
2: Pile Driving	Cranes	1	8.00	231	0.29
2: Pile Driving	Generator Sets	1	8.00	84	0.74
2: Pile Driving	Air Compressors	1	8.00	78	0.48
3: Concrete Foundations	Generator Sets	1	8.00	84	0.74
3: Concrete Foundations	Air Compressors	1	8.00	78	0.48
4: Concrete Slabs	Off-Highway Trucks	1	8.00	402	0.38
4: Concrete Slabs	Plate Compactors	1	8.00	8	0.43
4: Concrete Slabs	Generator Sets	1	8.00	84	0.74
4: Concrete Slabs	Air Compressors	1	8.00	78	0.48
5: Perimeter Wall	Plate Compactors	1	8.00	8	0.43
5: Perimeter Wall	Generator Sets	1	8.00	84	0.74
5: Perimeter Wall	Air Compressors	1	8.00	78	0.48
6: Backfill and Grading	Off-Highway Trucks	1	8.00	402	0.38

BCTD DB-130 - San Francisco County, Annual

6: Backfill and Grading	Plate Compactors	1	8.00	8	0.43
6: Backfill and Grading	Generator Sets	1	8.00	84	0.74
6: Backfill and Grading	Air Compressors	1	8.00	78	0.48
7: Electrical Equipment/Gate Install	Tractors/Loaders/Backhoes	1	8.00	97	0.37
7: Electrical Equipment/Gate Install	Cranes	1	8.00	231	0.29
7: Electrical Equipment/Gate Install	Generator Sets	1	8.00	84	0.74
7: Electrical Equipment/Gate Install	Air Compressors	1	8.00	78	0.48

Trips and VMT

Phase Name	Offroad Equipment Count	Worker Trip Number	Vendor Trip Number	Hauling Trip Number	Worker Trip Length	Vendor Trip Length	Hauling Trip Length	Worker Vehicle Class	Vendor Vehicle Class	Hauling Vehicle Class
4: Concrete Slabs	5	26.00	5.00	0.00	10.80	7.30	20.00	LD_Mix	HDT_Mix	HHDT
1: Site Excavation	6	26.00	0.00	291.00	10.80	7.30	20.00	LD_Mix	HDT_Mix	HHDT
2: Pile Driving	4	20.00	0.00	0.00	10.80	7.30	20.00	LD_Mix	HDT_Mix	HHDT
3: Concrete Foundations	4	22.00	0.00	0.00	10.80	7.30	20.00	LD_Mix	HDT_Mix	HHDT
5: Perimeter Wall	5	24.00	5.00	0.00	10.80	7.30	20.00	LD_Mix	HDT_Mix	HHDT
6: Backfill and Grading	5	24.00	0.00	469.00	10.80	7.30	20.00	LD_Mix	HDT_Mix	HHDT
7: Electrical Equipment/Gate Install	4	22.00	0.00	0.00	10.80	7.30	20.00	LD_Mix	HDT_Mix	HHDT

3.1 Mitigation Measures Construction

- Use Alternative Fuel for Construction Equipment
- Use Cleaner Engines for Construction Equipment
- Use DPF for Construction Equipment
- Water Exposed Area

BCTD DB-130 - San Francisco County, Annual

3.2 1:Site Excavation - 2020
Unmitigated Construction On-Site

Category	tons/yr											MT/yr				
	ROG	NOx	CO	SO2	Fugitive PM10	Exhaust PM10	PM10 Total	Fugitive PM2.5	Exhaust PM2.5	PM2.5 Total	Bio- CO2	NBio- CO2	Total CO2	CH4	N2O	CO2e
Fugitive Dust					6.1000e-004	0.0000	6.1000e-004	8.0000e-005	0.0000	8.0000e-005	0.0000	0.0000	0.0000	0.0000	0.0000	0.0000
Off-Road	0.0146	0.1276	0.1406	2.4000e-004	7.1900e-003	7.1900e-003	6.9400e-003	6.9400e-003	6.9400e-003	6.9400e-003	0.0000	20.5276	20.5276	3.9200e-003	0.0000	20.6256
Total	0.0146	0.1276	0.1406	2.4000e-004	6.1000e-004	7.1900e-003	7.8000e-003	8.0000e-005	6.9400e-003	7.0200e-003	0.0000	20.5276	20.5276	3.9200e-003	0.0000	20.6256

Unmitigated Construction Off-Site

Category	tons/yr											MT/yr				
	ROG	NOx	CO	SO2	Fugitive PM10	Exhaust PM10	PM10 Total	Fugitive PM2.5	Exhaust PM2.5	PM2.5 Total	Bio- CO2	NBio- CO2	Total CO2	CH4	N2O	CO2e
Hauling	1.1600e-003	0.0507	0.0150	1.2000e-004	2.4400e-003	1.5000e-004	2.5900e-003	6.7000e-004	1.4000e-004	8.1000e-004	0.0000	12.9982	12.9982	2.3300e-003	0.0000	13.0564
Vendor	0.0000	0.0000	0.0000	0.0000	0.0000	0.0000	0.0000	0.0000	0.0000	0.0000	0.0000	0.0000	0.0000	0.0000	0.0000	0.0000
Worker	9.1000e-004	6.0000e-004	6.7200e-003	2.0000e-005	2.3600e-003	2.0000e-005	2.3800e-003	6.3000e-004	2.0000e-005	6.5000e-004	0.0000	2.2455	2.2455	5.0000e-005	0.0000	2.2467
Total	2.0700e-003	0.0513	0.0217	1.4000e-004	4.8000e-003	1.7000e-004	4.9700e-003	1.3000e-003	1.6000e-004	1.4600e-003	0.0000	15.2437	15.2437	2.3800e-003	0.0000	15.3031

BCTD DB-130 - San Francisco County, Annual

3.2 1:Site Excavation - 2020

Mitigated Construction On-Site

Category	tons/yr											MT/yr				
	ROG	NOx	CO	SO2	Fugitive PM10	Exhaust PM10	PM10 Total	Fugitive PM2.5	Exhaust PM2.5	PM2.5 Total	Bio- CO2	NBio- CO2	Total CO2	CH4	N2O	CO2e
Fugitive Dust					2.7000e-004	0.0000	2.7000e-004	4.0000e-005	0.0000	4.0000e-005	0.0000	0.0000	0.0000	0.0000	0.0000	0.0000
Off-Road	6.2000e-003	0.1361	0.1102	2.4000e-004	7.1000e-004	7.1000e-004	7.1000e-004	7.1000e-004	7.1000e-004	7.1000e-004	0.0000	14.0277	14.0277	3.5500e-003	0.0000	14.1165
Total	6.2000e-003	0.1361	0.1102	2.4000e-004	2.7000e-004	7.1000e-004	9.8000e-004	4.0000e-005	7.1000e-004	7.5000e-004	0.0000	14.0277	14.0277	3.5500e-003	0.0000	14.1165

Mitigated Construction Off-Site

Category	tons/yr											MT/yr				
	ROG	NOx	CO	SO2	Fugitive PM10	Exhaust PM10	PM10 Total	Fugitive PM2.5	Exhaust PM2.5	PM2.5 Total	Bio- CO2	NBio- CO2	Total CO2	CH4	N2O	CO2e
Hauling	1.1600e-003	0.0507	0.0150	1.2000e-004	2.4400e-003	1.5000e-004	2.5900e-003	6.7000e-004	1.4000e-004	8.1000e-004	0.0000	12.9982	12.9982	2.3300e-003	0.0000	13.0564
Vendor	0.0000	0.0000	0.0000	0.0000	0.0000	0.0000	0.0000	0.0000	0.0000	0.0000	0.0000	0.0000	0.0000	0.0000	0.0000	0.0000
Worker	9.1000e-004	6.0000e-004	6.7200e-003	2.0000e-005	2.3600e-003	2.0000e-005	2.3800e-003	6.3000e-004	2.0000e-005	6.5000e-004	0.0000	2.2455	2.2455	5.0000e-005	0.0000	2.2467
Total	2.0700e-003	0.0513	0.0217	1.4000e-004	4.8000e-003	1.7000e-004	4.9700e-003	1.3000e-003	1.6000e-004	1.4600e-003	0.0000	15.2437	15.2437	2.3800e-003	0.0000	15.3031

BCTD DB-130 - San Francisco County, Annual

3.3.2: Pile Driving - 2020
Unmitigated Construction On-Site

Category	tons/yr											MT/yr				
	ROG	NOx	CO	SO2	Fugitive PM10	Exhaust PM10	PM10 Total	Fugitive PM2.5	Exhaust PM2.5	PM2.5 Total	Bio- CO2	NBio- CO2	Total CO2	CH4	N2O	CO2e
Fugitive Dust					0.0000	0.0000	0.0000	0.0000	0.0000	0.0000	0.0000	0.0000	0.0000	0.0000	0.0000	0.0000
Off-Road	0.0233	0.2342	0.1655	4.1000e-004	0.0107	0.0107	0.0107	0.0103	0.0103	0.0103	0.0000	35.8069	35.8069	7.8300e-003	0.0000	36.0025
Total	0.0233	0.2342	0.1655	4.1000e-004	0.0000	0.0107	0.0107	0.0000	0.0103	0.0103	0.0000	35.8069	35.8069	7.8300e-003	0.0000	36.0025

Unmitigated Construction Off-Site

Category	tons/yr											MT/yr				
	ROG	NOx	CO	SO2	Fugitive PM10	Exhaust PM10	PM10 Total	Fugitive PM2.5	Exhaust PM2.5	PM2.5 Total	Bio- CO2	NBio- CO2	Total CO2	CH4	N2O	CO2e
Hauling	0.0000	0.0000	0.0000	0.0000	0.0000	0.0000	0.0000	0.0000	0.0000	0.0000	0.0000	0.0000	0.0000	0.0000	0.0000	0.0000
Vendor	0.0000	0.0000	0.0000	0.0000	0.0000	0.0000	0.0000	0.0000	0.0000	0.0000	0.0000	0.0000	0.0000	0.0000	0.0000	0.0000
Worker	9.7000e-004	6.5000e-004	7.1900e-003	3.0000e-005	2.5300e-003	2.0000e-005	2.5500e-003	6.7000e-004	2.0000e-005	6.9000e-004	0.0000	2.4032	2.4032	5.0000e-005	0.0000	2.4045
Total	9.7000e-004	6.5000e-004	7.1900e-003	3.0000e-005	2.5300e-003	2.0000e-005	2.5500e-003	6.7000e-004	2.0000e-005	6.9000e-004	0.0000	2.4032	2.4032	5.0000e-005	0.0000	2.4045

BCTD DB-130 - San Francisco County, Annual

3.3.2: Pile Driving - 2020
Mitigated Construction On-Site

Category	tons/yr											MT/yr				
	ROG	NOx	CO	SO2	Fugitive PM10	Exhaust PM10	PM10 Total	Fugitive PM2.5	Exhaust PM2.5	PM2.5 Total	Bio- CO2	NBio- CO2	Total CO2	CH4	N2O	CO2e
Fugitive Dust					0.0000	0.0000	0.0000	0.0000	0.0000	0.0000	0.0000	0.0000	0.0000	0.0000	0.0000	0.0000
Off-Road	8.4400e-003	0.2580	0.1693	4.1000e-004	9.7000e-004	9.7000e-004	9.7000e-004	9.7000e-004	9.7000e-004	9.7000e-004	0.0000	26.7635	26.7635	7.3200e-003	0.0000	26.9464
Total	8.4400e-003	0.2580	0.1693	4.1000e-004	0.0000	9.7000e-004	9.7000e-004	0.0000	9.7000e-004	9.7000e-004	0.0000	26.7635	26.7635	7.3200e-003	0.0000	26.9464

Mitigated Construction Off-Site

Category	tons/yr											MT/yr				
	ROG	NOx	CO	SO2	Fugitive PM10	Exhaust PM10	PM10 Total	Fugitive PM2.5	Exhaust PM2.5	PM2.5 Total	Bio- CO2	NBio- CO2	Total CO2	CH4	N2O	CO2e
Hauling	0.0000	0.0000	0.0000	0.0000	0.0000	0.0000	0.0000	0.0000	0.0000	0.0000	0.0000	0.0000	0.0000	0.0000	0.0000	0.0000
Vendor	0.0000	0.0000	0.0000	0.0000	0.0000	0.0000	0.0000	0.0000	0.0000	0.0000	0.0000	0.0000	0.0000	0.0000	0.0000	0.0000
Worker	9.7000e-004	6.5000e-004	7.1900e-003	3.0000e-005	2.5300e-003	2.0000e-005	2.5500e-003	6.7000e-004	2.0000e-005	6.9000e-004	0.0000	2.4032	2.4032	5.0000e-005	0.0000	2.4045
Total	9.7000e-004	6.5000e-004	7.1900e-003	3.0000e-005	2.5300e-003	2.0000e-005	2.5500e-003	6.7000e-004	2.0000e-005	6.9000e-004	0.0000	2.4032	2.4032	5.0000e-005	0.0000	2.4045

BCTD DB-130 - San Francisco County, Annual

3.4 6: Backfill and Grading - 2021

Unmitigated Construction On-Site

Category	tons/yr											MT/yr				
	ROG	NOx	CO	SO2	Fugitive PM10	Exhaust PM10	PM10 Total	Fugitive PM2.5	Exhaust PM2.5	PM2.5 Total	Bio- CO2	NBio- CO2	Total CO2	CH4	N2O	CO2e
Fugitive Dust					5.5000e-004	0.0000	5.5000e-004	8.0000e-005	0.0000	8.0000e-005	0.0000	0.0000	0.0000	0.0000	0.0000	0.0000
Off-Road	0.0163	0.1387	0.1340	3.0000e-004	6.6900e-003	6.6900e-003	6.6900e-003	6.4200e-003	6.4200e-003	6.4200e-003	0.0000	26.0672	26.0672	5.7100e-003	0.0000	26.2099
Total	0.0163	0.1387	0.1340	3.0000e-004	5.5000e-004	6.6900e-003	7.2400e-003	8.0000e-005	6.4200e-003	6.5000e-003	0.0000	26.0672	26.0672	5.7100e-003	0.0000	26.2099

Unmitigated Construction Off-Site

Category	tons/yr											MT/yr				
	ROG	NOx	CO	SO2	Fugitive PM10	Exhaust PM10	PM10 Total	Fugitive PM2.5	Exhaust PM2.5	PM2.5 Total	Bio- CO2	NBio- CO2	Total CO2	CH4	N2O	CO2e
Hauling	1.7800e-003	0.0757	0.0248	1.9000e-004	3.9300e-003	2.2000e-004	4.1500e-003	1.0800e-003	2.1000e-004	1.2900e-003	0.0000	20.5768	20.5768	3.7700e-003	0.0000	20.6712
Vendor	0.0000	0.0000	0.0000	0.0000	0.0000	0.0000	0.0000	0.0000	0.0000	0.0000	0.0000	0.0000	0.0000	0.0000	0.0000	0.0000
Worker	7.5000e-004	4.8000e-004	5.4900e-003	2.0000e-005	2.0900e-003	2.0000e-005	2.1000e-003	5.5000e-004	1.0000e-005	5.7000e-004	0.0000	1.9118	1.9118	4.0000e-005	0.0000	1.9128
Total	2.5300e-003	0.0762	0.0303	2.1000e-004	6.0200e-003	2.4000e-004	6.2500e-003	1.6300e-003	2.2000e-004	1.8600e-003	0.0000	22.4886	22.4886	3.8100e-003	0.0000	22.5840

BCTD DB-130 - San Francisco County, Annual

3.4 6: Backfill and Grading - 2021

Mitigated Construction On-Site

Category	tons/yr											MT/yr				
	ROG	NOx	CO	SO2	Fugitive PM10	Exhaust PM10	PM10 Total	Fugitive PM2.5	Exhaust PM2.5	PM2.5 Total	Bio- CO2	NBio- CO2	Total CO2	CH4	N2O	CO2e
Fugitive Dust					2.5000e-004	0.0000	2.5000e-004	4.0000e-005	0.0000	4.0000e-005	0.0000	0.0000	0.0000	0.0000	0.0000	0.0000
Off-Road	6.8300e-003	0.1799	0.1297	3.0000e-004	8.0000e-004	8.0000e-004	8.0000e-004	8.0000e-004	8.0000e-004	8.0000e-004	0.0000	19.8499	19.8499	5.3900e-003	0.0000	19.9847
Total	6.8300e-003	0.1799	0.1297	3.0000e-004	2.5000e-004	8.0000e-004	1.0500e-003	4.0000e-005	8.0000e-004	8.4000e-004	0.0000	19.8499	19.8499	5.3900e-003	0.0000	19.9847

Mitigated Construction Off-Site

Category	tons/yr											MT/yr				
	ROG	NOx	CO	SO2	Fugitive PM10	Exhaust PM10	PM10 Total	Fugitive PM2.5	Exhaust PM2.5	PM2.5 Total	Bio- CO2	NBio- CO2	Total CO2	CH4	N2O	CO2e
Hauling	1.7800e-003	0.0757	0.0248	1.9000e-004	3.9300e-003	2.2000e-004	4.1500e-003	1.0800e-003	2.1000e-004	1.2900e-003	0.0000	20.5768	20.5768	3.7700e-003	0.0000	20.6712
Vendor	0.0000	0.0000	0.0000	0.0000	0.0000	0.0000	0.0000	0.0000	0.0000	0.0000	0.0000	0.0000	0.0000	0.0000	0.0000	0.0000
Worker	7.5000e-004	4.8000e-004	5.4900e-003	2.0000e-005	2.0900e-003	2.0000e-005	2.1000e-003	5.5000e-004	1.0000e-005	5.7000e-004	0.0000	1.9118	1.9118	4.0000e-005	0.0000	1.9128
Total	2.5300e-003	0.0762	0.0303	2.1000e-004	6.0200e-003	2.4000e-004	6.2500e-003	1.6300e-003	2.2000e-004	1.8600e-003	0.0000	22.4886	22.4886	3.8100e-003	0.0000	22.5840

BCTD DB-130 - San Francisco County, Annual

3.5.3: Concrete Foundations - 2020

Unmitigated Construction On-Site

Category	tons/yr											MT/yr				
	ROG	NOx	CO	SO2	Fugitive PM10	Exhaust PM10	PM10 Total	Fugitive PM2.5	Exhaust PM2.5	PM2.5 Total	Bio- CO2	NBio- CO2	Total CO2	CH4	N2O	CO2e
Off-Road	0.0152	0.1454	0.1160	2.1000e-004	7.6900e-003	7.6900e-003	7.6900e-003	7.3800e-003	7.3800e-003	7.3800e-003	0.0000	18.5396	18.5396	3.4100e-003	0.0000	18.6250
Total	0.0152	0.1454	0.1160	2.1000e-004	7.6900e-003	7.6900e-003	7.6900e-003	7.3800e-003	7.3800e-003	7.3800e-003	0.0000	18.5396	18.5396	3.4100e-003	0.0000	18.6250

Unmitigated Construction Off-Site

Category	tons/yr											MT/yr				
	ROG	NOx	CO	SO2	Fugitive PM10	Exhaust PM10	PM10 Total	Fugitive PM2.5	Exhaust PM2.5	PM2.5 Total	Bio- CO2	NBio- CO2	Total CO2	CH4	N2O	CO2e
Hauling	0.0000	0.0000	0.0000	0.0000	0.0000	0.0000	0.0000	0.0000	0.0000	0.0000	0.0000	0.0000	0.0000	0.0000	0.0000	0.0000
Vendor	0.0000	0.0000	0.0000	0.0000	0.0000	0.0000	0.0000	0.0000	0.0000	0.0000	0.0000	0.0000	0.0000	0.0000	0.0000	0.0000
Worker	7.4000e-004	4.9000e-004	5.4400e-003	2.0000e-005	1.9100e-003	1.0000e-005	1.9300e-003	5.1000e-004	1.0000e-005	5.2000e-004	0.0000	1.8174	1.8174	4.0000e-005	0.0000	1.8184
Total	7.4000e-004	4.9000e-004	5.4400e-003	2.0000e-005	1.9100e-003	1.0000e-005	1.9300e-003	5.1000e-004	1.0000e-005	5.2000e-004	0.0000	1.8174	1.8174	4.0000e-005	0.0000	1.8184

BCTD DB-130 - San Francisco County, Annual

3.5 3: Concrete Foundations - 2020

Mitigated Construction On-Site

Category	tons/yr											MT/yr				
	ROG	NOx	CO	SO2	Fugitive PM10	Exhaust PM10	PM10 Total	Fugitive PM2.5	Exhaust PM2.5	PM2.5 Total	Bio- CO2	NBio- CO2	Total CO2	CH4	N2O	CO2e
Off-Road	4.8300e-003	0.1215	0.0864	2.1000e-004	5.8000e-004	5.8000e-004	5.8000e-004	5.8000e-004	5.8000e-004	5.8000e-004	0.0000	12.3223	12.3223	3.0600e-003	0.0000	12.3989
Total	4.8300e-003	0.1215	0.0864	2.1000e-004	5.8000e-004	5.8000e-004	5.8000e-004	5.8000e-004	5.8000e-004	5.8000e-004	0.0000	12.3223	12.3223	3.0600e-003	0.0000	12.3989

Mitigated Construction Off-Site

Category	tons/yr											MT/yr				
	ROG	NOx	CO	SO2	Fugitive PM10	Exhaust PM10	PM10 Total	Fugitive PM2.5	Exhaust PM2.5	PM2.5 Total	Bio- CO2	NBio- CO2	Total CO2	CH4	N2O	CO2e
Hauling	0.0000	0.0000	0.0000	0.0000	0.0000	0.0000	0.0000	0.0000	0.0000	0.0000	0.0000	0.0000	0.0000	0.0000	0.0000	0.0000
Vendor	0.0000	0.0000	0.0000	0.0000	0.0000	0.0000	0.0000	0.0000	0.0000	0.0000	0.0000	0.0000	0.0000	0.0000	0.0000	0.0000
Worker	7.4000e-004	4.9000e-004	5.4400e-003	2.0000e-005	1.9100e-003	1.0000e-005	1.9300e-003	5.1000e-004	1.0000e-005	5.2000e-004	0.0000	1.8174	1.8174	4.0000e-005	0.0000	1.8184
Total	7.4000e-004	4.9000e-004	5.4400e-003	2.0000e-005	1.9100e-003	1.0000e-005	1.9300e-003	5.1000e-004	1.0000e-005	5.2000e-004	0.0000	1.8174	1.8174	4.0000e-005	0.0000	1.8184

BCTD DB-130 - San Francisco County, Annual

3.6.7: Electrical Equipment/Gate Install - 2021

Unmitigated Construction On-Site

Category	tons/yr											MT/yr				
	ROG	NOx	CO	SO2	Fugitive PM10	Exhaust PM10	PM10 Total	Fugitive PM2.5	Exhaust PM2.5	PM2.5 Total	Bio- CO2	NBio- CO2	Total CO2	CH4	N2O	CO2e
Off-Road	0.0119	0.1135	0.0983	1.8000e-004	5.7200e-003	5.7200e-003	5.7200e-003	5.4800e-003	5.4800e-003	5.4800e-003	0.0000	16.0122	16.0122	2.8900e-003	0.0000	16.0845
Total	0.0119	0.1135	0.0983	1.8000e-004	5.7200e-003	5.7200e-003	5.7200e-003	5.4800e-003	5.4800e-003	5.4800e-003	0.0000	16.0122	16.0122	2.8900e-003	0.0000	16.0845

Unmitigated Construction Off-Site

Category	tons/yr											MT/yr				
	ROG	NOx	CO	SO2	Fugitive PM10	Exhaust PM10	PM10 Total	Fugitive PM2.5	Exhaust PM2.5	PM2.5 Total	Bio- CO2	NBio- CO2	Total CO2	CH4	N2O	CO2e
Hauling	0.0000	0.0000	0.0000	0.0000	0.0000	0.0000	0.0000	0.0000	0.0000	0.0000	0.0000	0.0000	0.0000	0.0000	0.0000	0.0000
Vendor	0.0000	0.0000	0.0000	0.0000	0.0000	0.0000	0.0000	0.0000	0.0000	0.0000	0.0000	0.0000	0.0000	0.0000	0.0000	0.0000
Worker	5.9000e-004	3.8000e-004	4.3400e-003	2.0000e-005	1.6500e-003	1.0000e-005	1.6600e-003	4.4000e-004	1.0000e-005	4.5000e-004	0.0000	1.5135	1.5135	3.0000e-005	0.0000	1.5143
Total	5.9000e-004	3.8000e-004	4.3400e-003	2.0000e-005	1.6500e-003	1.0000e-005	1.6600e-003	4.4000e-004	1.0000e-005	4.5000e-004	0.0000	1.5135	1.5135	3.0000e-005	0.0000	1.5143

BCTD DB-130 - San Francisco County, Annual

3.6.7: Electrical Equipment/Gate Install - 2021

Mitigated Construction On-Site

Category	tons/yr										MT/yr					
	ROG	NOx	CO	SO2	Fugitive PM10	Exhaust PM10	PM10 Total	Fugitive PM2.5	Exhaust PM2.5	PM2.5 Total	Bio- CO2	NBio- CO2	Total CO2	CH4	N2O	CO2e
Off-Road	4.1700e-003	0.1049	0.0746	1.8000e-004	5.0000e-004	5.0000e-004	5.0000e-004	5.0000e-004	5.0000e-004	5.0000e-004	0.0000	10.6427	10.6427	2.6200e-003	0.0000	10.7082
Total	4.1700e-003	0.1049	0.0746	1.8000e-004	5.0000e-004	5.0000e-004	5.0000e-004	5.0000e-004	5.0000e-004	5.0000e-004	0.0000	10.6427	10.6427	2.6200e-003	0.0000	10.7082

Mitigated Construction Off-Site

Category	tons/yr										MT/yr					
	ROG	NOx	CO	SO2	Fugitive PM10	Exhaust PM10	PM10 Total	Fugitive PM2.5	Exhaust PM2.5	PM2.5 Total	Bio- CO2	NBio- CO2	Total CO2	CH4	N2O	CO2e
Hauling	0.0000	0.0000	0.0000	0.0000	0.0000	0.0000	0.0000	0.0000	0.0000	0.0000	0.0000	0.0000	0.0000	0.0000	0.0000	0.0000
Vendor	0.0000	0.0000	0.0000	0.0000	0.0000	0.0000	0.0000	0.0000	0.0000	0.0000	0.0000	0.0000	0.0000	0.0000	0.0000	0.0000
Worker	5.9000e-004	3.8000e-004	4.3400e-003	2.0000e-005	1.6500e-003	1.0000e-005	1.6600e-003	4.4000e-004	1.0000e-005	4.5000e-004	0.0000	1.5135	1.5135	3.0000e-005	0.0000	1.5143
Total	5.9000e-004	3.8000e-004	4.3400e-003	2.0000e-005	1.6500e-003	1.0000e-005	1.6600e-003	4.4000e-004	1.0000e-005	4.5000e-004	0.0000	1.5135	1.5135	3.0000e-005	0.0000	1.5143

BCTD DB-130 - San Francisco County, Annual

3.7 4: Concrete Slabs - 2020
Unmitigated Construction On-Site

Category	tons/yr											MT/yr				
	ROG	NOx	CO	SO2	Fugitive PM10	Exhaust PM10	PM10 Total	Fugitive PM2.5	Exhaust PM2.5	PM2.5 Total	Bio- CO2	NBio- CO2	Total CO2	CH4	N2O	CO2e
Off-Road	0.0319	0.2809	0.2427	5.3000e-004		0.0140	0.0140		0.0134	0.0134	0.0000	46.2095	46.2095	0.0102	0.0000	46.4654
Total	0.0319	0.2809	0.2427	5.3000e-004		0.0140	0.0140		0.0134	0.0134	0.0000	46.2095	46.2095	0.0102	0.0000	46.4654

Unmitigated Construction Off-Site

Category	tons/yr											MT/yr				
	ROG	NOx	CO	SO2	Fugitive PM10	Exhaust PM10	PM10 Total	Fugitive PM2.5	Exhaust PM2.5	PM2.5 Total	Bio- CO2	NBio- CO2	Total CO2	CH4	N2O	CO2e
Hauling	0.0000	0.0000	0.0000	0.0000	0.0000	0.0000	0.0000	0.0000	0.0000	0.0000	0.0000	0.0000	0.0000	0.0000	0.0000	0.0000
Vendor	3.6000e-004	0.0122	3.6100e-003	3.0000e-005	6.4000e-004	5.0000e-005	6.9000e-004	1.8000e-004	5.0000e-005	2.4000e-004	0.0000	2.6989	2.6989	3.6000e-004	0.0000	2.7079
Worker	1.5400e-003	1.0300e-003	0.0114	4.0000e-005	4.0100e-003	3.0000e-005	4.0400e-003	1.0700e-003	3.0000e-005	1.0900e-003	0.0000	3.8075	3.8075	8.0000e-005	0.0000	3.8096
Total	1.9000e-003	0.0132	0.0150	7.0000e-005	4.6500e-003	8.0000e-005	4.7300e-003	1.2500e-003	8.0000e-005	1.3300e-003	0.0000	6.5064	6.5064	4.4000e-004	0.0000	6.5175

BCTD DB-130 - San Francisco County, Annual

3.7 4: Concrete Slabs - 2020

Mitigated Construction On-Site

Category	tons/yr										MT/yr					
	ROG	NOx	CO	SO2	Fugitive PM10	Exhaust PM10	PM10 Total	Fugitive PM2.5	Exhaust PM2.5	PM2.5 Total	Bio- CO2	NBio- CO2	Total CO2	CH4	N2O	CO2e
Off-Road	0.0121	0.3189	0.2299	5.3000e-004	1.4200e-003	1.4200e-003	1.4200e-003	1.4200e-003	1.4200e-003	1.4200e-003	0.0000	35.1879	35.1879	9.6100e-003	0.0000	35.4283
Total	0.0121	0.3189	0.2299	5.3000e-004	1.4200e-003	1.4200e-003	1.4200e-003	1.4200e-003	1.4200e-003	1.4200e-003	0.0000	35.1879	35.1879	9.6100e-003	0.0000	35.4283

Mitigated Construction Off-Site

Category	tons/yr										MT/yr					
	ROG	NOx	CO	SO2	Fugitive PM10	Exhaust PM10	PM10 Total	Fugitive PM2.5	Exhaust PM2.5	PM2.5 Total	Bio- CO2	NBio- CO2	Total CO2	CH4	N2O	CO2e
Hauling	0.0000	0.0000	0.0000	0.0000	0.0000	0.0000	0.0000	0.0000	0.0000	0.0000	0.0000	0.0000	0.0000	0.0000	0.0000	0.0000
Vendor	3.6000e-004	0.0122	3.6100e-003	3.0000e-005	6.4000e-004	5.0000e-005	6.9000e-004	1.8000e-004	5.0000e-005	2.4000e-004	0.0000	2.6989	2.6989	3.6000e-004	0.0000	2.7079
Worker	1.5400e-003	1.0300e-003	0.0114	4.0000e-005	4.0100e-003	3.0000e-005	4.0400e-003	1.0700e-003	3.0000e-005	1.0900e-003	0.0000	3.8075	3.8075	8.0000e-005	0.0000	3.8096
Total	1.9000e-003	0.0132	0.0150	7.0000e-005	4.6500e-003	8.0000e-005	4.7300e-003	1.2500e-003	8.0000e-005	1.3300e-003	0.0000	6.5064	6.5064	4.4000e-004	0.0000	6.5175

BCTD DB-130 - San Francisco County, Annual

3.8.5: Perimeter Wall - 2020
Unmitigated Construction On-Site

Category	tons/yr											MT/yr				
	ROG	NOx	CO	SO2	Fugitive PM10	Exhaust PM10	PM10 Total	Fugitive PM2.5	Exhaust PM2.5	PM2.5 Total	Bio- CO2	NBio- CO2	Total CO2	CH4	N2O	CO2e
Off-Road	0.0271	0.2560	0.2043	3.8000e-004		0.0135	0.0135		0.0129	0.0129	0.0000	32.6173	32.6173	5.9600e-003	0.0000	32.7662
Total	0.0271	0.2560	0.2043	3.8000e-004		0.0135	0.0135		0.0129	0.0129	0.0000	32.6173	32.6173	5.9600e-003	0.0000	32.7662

Unmitigated Construction Off-Site

Category	tons/yr											MT/yr				
	ROG	NOx	CO	SO2	Fugitive PM10	Exhaust PM10	PM10 Total	Fugitive PM2.5	Exhaust PM2.5	PM2.5 Total	Bio- CO2	NBio- CO2	Total CO2	CH4	N2O	CO2e
Hauling	0.0000	0.0000	0.0000	0.0000	0.0000	0.0000	0.0000	0.0000	0.0000	0.0000	0.0000	0.0000	0.0000	0.0000	0.0000	0.0000
Vendor	3.5000e-004	0.0119	3.5100e-003	3.0000e-005	6.2000e-004	5.0000e-005	6.7000e-004	1.8000e-004	5.0000e-005	2.3000e-004	0.0000	2.6297	2.6297	3.5000e-004	0.0000	2.6385
Worker	1.3900e-003	9.2000e-004	0.0103	4.0000e-005	3.6000e-003	3.0000e-005	3.6300e-003	9.6000e-004	3.0000e-005	9.8000e-004	0.0000	3.4245	3.4245	8.0000e-005	0.0000	3.4264
Total	1.7400e-003	0.0128	0.0138	7.0000e-005	4.2200e-003	8.0000e-005	4.3000e-003	1.1400e-003	8.0000e-005	1.2100e-003	0.0000	6.0542	6.0542	4.3000e-004	0.0000	6.0649

BCTD DB-130 - San Francisco County, Annual

3.8.5: Perimeter Wall - 2020
Mitigated Construction On-Site

Category	tons/yr											MT/yr				
	ROG	NOx	CO	SO2	Fugitive PM10	Exhaust PM10	PM10 Total	Fugitive PM2.5	Exhaust PM2.5	PM2.5 Total	Bio- CO2	NBio- CO2	Total CO2	CH4	N2O	CO2e
Off-Road	8.3500e-003	0.2099	0.1493	3.8000e-004	1.0000e-003	1.0000e-003	1.0000e-003	1.0000e-003	1.0000e-003	1.0000e-003	0.0000	21.8783	21.8783	5.3500e-003	0.0000	22.0122
Total	8.3500e-003	0.2099	0.1493	3.8000e-004	1.0000e-003	1.0000e-003	1.0000e-003	1.0000e-003	1.0000e-003	1.0000e-003	0.0000	21.8783	21.8783	5.3500e-003	0.0000	22.0122

Mitigated Construction Off-Site

Category	tons/yr											MT/yr				
	ROG	NOx	CO	SO2	Fugitive PM10	Exhaust PM10	PM10 Total	Fugitive PM2.5	Exhaust PM2.5	PM2.5 Total	Bio- CO2	NBio- CO2	Total CO2	CH4	N2O	CO2e
Hauling	0.0000	0.0000	0.0000	0.0000	0.0000	0.0000	0.0000	0.0000	0.0000	0.0000	0.0000	0.0000	0.0000	0.0000	0.0000	0.0000
Vendor	3.5000e-004	0.0119	3.5100e-003	3.0000e-005	6.2000e-004	5.0000e-005	6.7000e-004	1.8000e-004	5.0000e-005	2.3000e-004	0.0000	2.6297	2.6297	3.5000e-004	0.0000	2.6385
Worker	1.3900e-003	9.2000e-004	0.0103	4.0000e-005	3.6000e-003	3.0000e-005	3.6300e-003	9.6000e-004	3.0000e-005	9.8000e-004	0.0000	3.4245	3.4245	8.0000e-005	0.0000	3.4264
Total	1.7400e-003	0.0128	0.0138	7.0000e-005	4.2200e-003	8.0000e-005	4.3000e-003	1.1400e-003	8.0000e-005	1.2100e-003	0.0000	6.0542	6.0542	4.3000e-004	0.0000	6.0649

BCTD DB-130 - San Francisco County, Annual

3.8.5: Perimeter Wall - 2021
Unmitigated Construction On-Site

Category	tons/yr											MT/yr				
	ROG	NOx	CO	SO2	Fugitive PM10	Exhaust PM10	PM10 Total	Fugitive PM2.5	Exhaust PM2.5	PM2.5 Total	Bio- CO2	NBio- CO2	Total CO2	CH4	N2O	CO2e
Off-Road	6.4000e-004	6.1000e-003	5.2800e-003	1.0000e-005	3.1000e-004	3.1000e-004	3.1000e-004	2.9000e-004	2.9000e-004	2.9000e-004	0.0000	0.8584	0.8584	1.5000e-004	0.0000	0.8622
Total	6.4000e-004	6.1000e-003	5.2800e-003	1.0000e-005	3.1000e-004	3.1000e-004	3.1000e-004	2.9000e-004	2.9000e-004	2.9000e-004	0.0000	0.8584	0.8584	1.5000e-004	0.0000	0.8622

Unmitigated Construction Off-Site

Category	tons/yr											MT/yr				
	ROG	NOx	CO	SO2	Fugitive PM10	Exhaust PM10	PM10 Total	Fugitive PM2.5	Exhaust PM2.5	PM2.5 Total	Bio- CO2	NBio- CO2	Total CO2	CH4	N2O	CO2e
Hauling	0.0000	0.0000	0.0000	0.0000	0.0000	0.0000	0.0000	0.0000	0.0000	0.0000	0.0000	0.0000	0.0000	0.0000	0.0000	0.0000
Vendor	1.0000e-005	2.9000e-004	9.0000e-005	0.0000	2.0000e-005	0.0000	2.0000e-005	0.0000	0.0000	1.0000e-005	0.0000	0.0683	0.0683	1.0000e-005	0.0000	0.0686
Worker	3.0000e-005	2.0000e-005	2.5000e-004	0.0000	9.0000e-005	0.0000	1.0000e-004	3.0000e-005	0.0000	3.0000e-005	0.0000	0.0869	0.0869	0.0000	0.0000	0.0870
Total	4.0000e-005	3.1000e-004	3.4000e-004	0.0000	1.1000e-004	0.0000	1.2000e-004	3.0000e-005	0.0000	4.0000e-005	0.0000	0.1552	0.1552	1.0000e-005	0.0000	0.1555

BCTD DB-130 - San Francisco County, Annual

3.8 5: Perimeter Wall - 2021

Mitigated Construction On-Site

Category	tons/yr											MT/yr				
	ROG	NOX	CO	SO2	Fugitive PM10	Exhaust PM10	PM10 Total	Fugitive PM2.5	Exhaust PM2.5	PM2.5 Total	Bio- CO2	NBio- CO2	Total CO2	CH4	N2O	CO2e
Off-Road	2.2000e-004	5.5200e-003	3.9300e-003	1.0000e-005	3.0000e-005	3.0000e-005	3.0000e-005	3.0000e-005	3.0000e-005	3.0000e-005	0.0000	0.5758	0.5758	1.4000e-004	0.0000	0.5793
Total	2.2000e-004	5.5200e-003	3.9300e-003	1.0000e-005	3.0000e-005	3.0000e-005	3.0000e-005	3.0000e-005	3.0000e-005	3.0000e-005	0.0000	0.5758	0.5758	1.4000e-004	0.0000	0.5793

Mitigated Construction Off-Site

Category	tons/yr											MT/yr				
	ROG	NOX	CO	SO2	Fugitive PM10	Exhaust PM10	PM10 Total	Fugitive PM2.5	Exhaust PM2.5	PM2.5 Total	Bio- CO2	NBio- CO2	Total CO2	CH4	N2O	CO2e
Hauling	0.0000	0.0000	0.0000	0.0000	0.0000	0.0000	0.0000	0.0000	0.0000	0.0000	0.0000	0.0000	0.0000	0.0000	0.0000	0.0000
Vendor	1.0000e-005	2.9000e-004	9.0000e-005	0.0000	2.0000e-005	0.0000	2.0000e-005	0.0000	0.0000	1.0000e-005	0.0000	0.0683	0.0683	1.0000e-005	0.0000	0.0686
Worker	3.0000e-005	2.0000e-005	2.5000e-004	0.0000	9.0000e-005	0.0000	1.0000e-004	3.0000e-005	0.0000	3.0000e-005	0.0000	0.0869	0.0869	0.0000	0.0000	0.0870
Total	4.0000e-005	3.1000e-004	3.4000e-004	0.0000	1.1000e-004	0.0000	1.2000e-004	3.0000e-005	0.0000	4.0000e-005	0.0000	0.1552	0.1552	1.0000e-005	0.0000	0.1555

4.0 Operational Detail - Mobile

BCTD DB-130 - San Francisco County, Annual

4.1 Mitigation Measures Mobile

Category	tons/yr										MT/yr					
	ROG	NOx	CO	SO2	Fugitive PM10	Exhaust PM10	PM10 Total	Fugitive PM2.5	Exhaust PM2.5	PM2.5 Total	Bio- CO2	NBio- CO2	Total CO2	CH4	N2O	CO2e
Mitigated	0.0000	0.0000	0.0000	0.0000	0.0000	0.0000	0.0000	0.0000	0.0000	0.0000	0.0000	0.0000	0.0000	0.0000	0.0000	0.0000
Unmitigated	0.0000	0.0000	0.0000	0.0000	0.0000	0.0000	0.0000	0.0000	0.0000	0.0000	0.0000	0.0000	0.0000	0.0000	0.0000	0.0000

4.2 Trip Summary Information

Land Use	Average Daily Trip Rate			Unmitigated Annual VMT	Mitigated Annual VMT
	Weekday	Saturday	Sunday		
User Defined Industrial	0.00	0.00	0.00		
Total	0.00	0.00	0.00		

4.3 Trip Type Information

Land Use	Miles				Trip %				Trip Purpose %			
	H-W or C-W	H-S or C-C	H-O or C-NW	H-W or C-W	H-S or C-C	H-O or C-NW	Primary	Diverted	Pass-by	Primary	Diverted	Pass-by
User Defined Industrial	9.50	7.30	7.30	0.00	0.00	0.00	0.00	0.00	0.00	0.00	0.00	0.00

4.4 Fleet Mix

Land Use	LDA	LDT1	LDT2	MDV	LHD1	LHD2	MHD	HHD	OBUS	UBUS	MCY	SBUS	MH
User Defined Industrial	0.606408	0.040118	0.191445	0.088323	0.014900	0.004926	0.028280	0.008891	0.004289	0.004272	0.006741	0.000931	0.000477

5.3 Energy by Land Use - Electricity

Unmitigated

Land Use	Electricity Use	Total CO2	CH4	N2O	CO2e
	kWh/yr	MT/yr			
User Defined Industrial	0	0.0000	0.0000	0.0000	0.0000
Total		0.0000	0.0000	0.0000	0.0000

Mitigated

Land Use	Electricity Use	Total CO2	CH4	N2O	CO2e
	kWh/yr	MT/yr			
User Defined Industrial	0	0.0000	0.0000	0.0000	0.0000
Total		0.0000	0.0000	0.0000	0.0000

6.0 Area Detail

6.1 Mitigation Measures Area

BCTD DB-130 - San Francisco County, Annual

Category	ROG	NOx	CO	SO2	Fugitive PM10	Exhaust PM10	PM10 Total	Fugitive PM2.5	Exhaust PM2.5	PM2.5 Total	Bio- CO2	NBio- CO2	Total CO2	CH4	N2O	CO2e	
tons/yr																	
MT/yr																	
Mitigated	0.0000	0.0000	1.0000e-005	0.0000	0.0000	0.0000	0.0000	0.0000	0.0000	0.0000	0.0000	2.0000e-005	2.0000e-005	0.0000	0.0000	0.0000	2.0000e-005
Unmitigated	0.0000	0.0000	1.0000e-005	0.0000	0.0000	0.0000	0.0000	0.0000	0.0000	0.0000	0.0000	2.0000e-005	2.0000e-005	0.0000	0.0000	0.0000	2.0000e-005

6.2 Area by SubCategory

Unmitigated

SubCategory	ROG	NOx	CO	SO2	Fugitive PM10	Exhaust PM10	PM10 Total	Fugitive PM2.5	Exhaust PM2.5	PM2.5 Total	Bio- CO2	NBio- CO2	Total CO2	CH4	N2O	CO2e	
tons/yr																	
MT/yr																	
Architectural Coating	0.0000					0.0000	0.0000		0.0000	0.0000	0.0000	0.0000	0.0000	0.0000	0.0000	0.0000	0.0000
Consumer Products	0.0000					0.0000	0.0000		0.0000	0.0000	0.0000	0.0000	0.0000	0.0000	0.0000	0.0000	0.0000
Landscaping	0.0000	0.0000	1.0000e-005	0.0000		0.0000	0.0000		0.0000	0.0000	0.0000	2.0000e-005	2.0000e-005	0.0000	0.0000	0.0000	2.0000e-005
Total	0.0000	0.0000	1.0000e-005	0.0000		0.0000	0.0000		0.0000	0.0000	0.0000	2.0000e-005	2.0000e-005	0.0000	0.0000	0.0000	2.0000e-005

BCTD DB-130 - San Francisco County, Annual

6.2 Area by SubCategory

Mitigated

SubCategory	tons/yr											MT/yr					
	ROG	NOx	CO	SO2	Fugitive PM10	Exhaust PM10	PM10 Total	Fugitive PM2.5	Exhaust PM2.5	PM2.5 Total	Bio- CO2	NBio- CO2	Total CO2	CH4	N2O	CO2e	
Architectural Coating	0.0000					0.0000	0.0000	0.0000	0.0000	0.0000	0.0000	0.0000	0.0000	0.0000	0.0000	0.0000	0.0000
Consumer Products	0.0000					0.0000	0.0000	0.0000	0.0000	0.0000	0.0000	0.0000	0.0000	0.0000	0.0000	0.0000	0.0000
Landscaping	0.0000	0.0000	1.0000e-005	0.0000		0.0000	0.0000	0.0000	0.0000	0.0000	0.0000	2.0000e-005	2.0000e-005	0.0000	0.0000	0.0000	2.0000e-005
Total	0.0000	0.0000	1.0000e-005	0.0000		0.0000	0.0000	0.0000	0.0000	0.0000	0.0000	2.0000e-005	2.0000e-005	0.0000	0.0000	0.0000	2.0000e-005

7.0 Water Detail

7.1 Mitigation Measures Water

BCTD DB-130 - San Francisco County, Annual

	Total CO2	CH4	N2O	CO2e
Category	MT/yr			
Mitigated	0.0000	0.0000	0.0000	0.0000
Unmitigated	0.0000	0.0000	0.0000	0.0000

7.2 Water by Land Use

Unmitigated

	Indoor/Outdoor Use	Total CO2	CH4	N2O	CO2e
Land Use	Mgal	MT/yr			
User Defined Industrial	0 / 0	0.0000	0.0000	0.0000	0.0000
Total		0.0000	0.0000	0.0000	0.0000

BCTD DB-130 - San Francisco County, Annual

7.2 Water by Land Use

Mitigated

Land Use	Indoor/Outdoor Use	Total CO2	CH4	N2O	CO2e
	Mgal	MT/yr			
User Defined Industrial	0 / 0	0.0000	0.0000	0.0000	0.0000
Total		0.0000	0.0000	0.0000	0.0000

8.0 Waste Detail

8.1 Mitigation Measures Waste

Category/Year

Category/Year	Total CO2	CH4	N2O	CO2e
	MT/yr			
Mitigated	0.0000	0.0000	0.0000	0.0000
Unmitigated	0.0000	0.0000	0.0000	0.0000

BCTD DB-130 - San Francisco County, Annual

8.2 Waste by Land Use

Unmitigated

Land Use	Waste Disposed tons	MT/yr			
		Total CO2	CH4	N2O	CO2e
User Defined Industrial	0	0.0000	0.0000	0.0000	0.0000
Total		0.0000	0.0000	0.0000	0.0000

Mitigated

Land Use	Waste Disposed tons	MT/yr			
		Total CO2	CH4	N2O	CO2e
User Defined Industrial	0	0.0000	0.0000	0.0000	0.0000
Total		0.0000	0.0000	0.0000	0.0000

9.0 Operational Offroad

Equipment Type	Number	Hours/Day	Days/Year	Horse Power	Load Factor	Fuel Type
----------------	--------	-----------	-----------	-------------	-------------	-----------

BCTD DB-130 - San Francisco County, Annual

10.0 Stationary Equipment

Fire Pumps and Emergency Generators

Equipment Type	Number	Hours/Day	Hours/Year	Horse Power	Load Factor	Fuel Type

Boilers

Equipment Type	Number	Heat Input/Day	Heat Input/Year	Boiler Rating	Fuel Type

User Defined Equipment

Equipment Type	Number

11.0 Vegetation

BCTD DB-130 - San Francisco County, Annual

BCTD DB-130
San Francisco County, Annual

1.0 Project Characteristics

1.1 Land Usage

Land Uses	Size	Metric	Lot Acreage	Floor Surface Area	Population
User Defined Industrial	1.00	User Defined Unit	0.31	0.00	0

1.2 Other Project Characteristics

Urbanization	Urban	Wind Speed (m/s)	4.6	Precipitation Freq (Days)	64
Climate Zone	5			Operational Year	2021

Utility Company Pacific Gas & Electric Company

CO2 Intensity (lb/MW/hr)	641.35	CH4 Intensity (lb/MW/hr)	0.029	N2O Intensity (lb/MW/hr)	0.006
---------------------------------	--------	---------------------------------	-------	---------------------------------	-------

1.3 User Entered Comments & Non-Default Data

BCTD DB-130 - San Francisco County, Annual

Project Characteristics -

Land Use - Project specific acreage based on 13,400 sq. ft.

Construction Phase - Project specific construction schedule.

Off-road Equipment - Project specific equipment.

Off-road Equipment - Project specific equipment.

Off-road Equipment - Project specific equipment.

Off-road Equipment - Project specific equipment.

Off-road Equipment - Project specific equipment.

Off-road Equipment - Project specific equipment.

Off-road Equipment - Project specific equipment.

Grading - Assumes approximately 2,325 CY of material export and 3,750 CY of material import.

Trips and VMT - Based on 10-13 workers per day per phase and approximately 1,455 CY of concrete placement (modeled as concrete truck trips). Haul truck capacity assumed to be 16 CY.

Construction Off-road Equipment Mitigation - Assumes fugitive dust control and Tier 4 Final engines. Assumes generator is electric.

Table Name	Column Name	Default Value	New Value
tblConstEquipMitigation	FuelType	Diesel	Electrical
tblConstEquipMitigation	NumberOfEquipmentMitigated	0.00	7.00
tblConstEquipMitigation	NumberOfEquipmentMitigated	0.00	1.00
tblConstEquipMitigation	NumberOfEquipmentMitigated	0.00	4.00
tblConstEquipMitigation	NumberOfEquipmentMitigated	0.00	1.00
tblConstEquipMitigation	NumberOfEquipmentMitigated	0.00	7.00
tblConstEquipMitigation	NumberOfEquipmentMitigated	0.00	6.00
tblConstEquipMitigation	NumberOfEquipmentMitigated	0.00	3.00
tblConstEquipMitigation	NumberOfEquipmentMitigated	0.00	4.00
tblConstEquipMitigation	Tier	No Change	Tier 4 Final
tblConstEquipMitigation	Tier	No Change	Tier 4 Final
tblConstEquipMitigation	Tier	No Change	Tier 4 Final

BCTD DB-130 - San Francisco County, Annual

tblConstEquipMitigation	Tier	No Change	Tier 4 Final
tblConstEquipMitigation	Tier	No Change	Tier 4 Final
tblConstEquipMitigation	Tier	No Change	Tier 4 Final
tblConstEquipMitigation	Tier	No Change	Tier 4 Final
tblConstructionPhase	NumDays	100.00	22.00
tblConstructionPhase	NumDays	2.00	32.00
tblConstructionPhase	NumDays	1.00	23.00
tblConstructionPhase	NumDays	100.00	39.00
tblConstructionPhase	NumDays	100.00	39.00
tblConstructionPhase	NumDays	2.00	22.00
tblConstructionPhase	PhaseEndDate	10/23/2020	9/15/2020
tblConstructionPhase	PhaseEndDate	6/3/2020	8/14/2020
tblConstructionPhase	PhaseEndDate	6/1/2020	7/1/2020
tblConstructionPhase	PhaseEndDate	3/12/2021	11/9/2020
tblConstructionPhase	PhaseEndDate	7/30/2021	1/1/2021
tblConstructionPhase	PhaseEndDate	6/5/2020	2/2/2021
tblConstructionPhase	PhaseEndDate	6/5/2020	3/1/2021
tblConstructionPhase	PhaseStartDate	6/6/2020	8/15/2020
tblConstructionPhase	PhaseStartDate	6/2/2020	7/2/2020
tblConstructionPhase	PhaseStartDate	10/24/2020	9/16/2020
tblConstructionPhase	PhaseStartDate	3/13/2021	11/10/2020
tblConstructionPhase	PhaseStartDate	6/4/2020	1/2/2021
tblConstructionPhase	PhaseStartDate	6/6/2020	2/3/2021
tblGrading	AcresOfGrading	0.00	0.50
tblGrading	MaterialExported	0.00	2,325.00
tblGrading	MaterialImported	0.00	3,750.00
tblLandUse	LotAcreage	0.00	0.31

BCTD DB-130 - San Francisco County, Annual

tbOffRoadEquipment	OffRoadEquipmentType	Excavators	
tbOffRoadEquipment	OffRoadEquipmentType	Off-Highway Trucks	
tbOffRoadEquipment	OffRoadEquipmentType	Plate Compactors	
tbOffRoadEquipment	OffRoadEquipmentType	Generator Sets	
tbOffRoadEquipment	OffRoadEquipmentType	Air Compressors	
tbOffRoadEquipment	OffRoadEquipmentType	Bore/Drill Rigs	
tbOffRoadEquipment	OffRoadEquipmentType	Cranes	
tbOffRoadEquipment	OffRoadEquipmentType	Generator Sets	
tbOffRoadEquipment	OffRoadEquipmentType	Air Compressors	
tbOffRoadEquipment	OffRoadEquipmentType	Generator Sets	
tbOffRoadEquipment	OffRoadEquipmentType	Air Compressors	
tbOffRoadEquipment	OffRoadEquipmentType	Off-Highway Trucks	
tbOffRoadEquipment	OffRoadEquipmentType	Plate Compactors	
tbOffRoadEquipment	OffRoadEquipmentType	Generator Sets	
tbOffRoadEquipment	OffRoadEquipmentType	Air Compressors	
tbOffRoadEquipment	OffRoadEquipmentType	Off-Highway Trucks	
tbOffRoadEquipment	OffRoadEquipmentType	Plate Compactors	
tbOffRoadEquipment	OffRoadEquipmentType	Generator Sets	
tbOffRoadEquipment	OffRoadEquipmentType	Air Compressors	
tbOffRoadEquipment	OffRoadEquipmentType	Tractors/Loaders/Backhoes	
tbOffRoadEquipment	OffRoadEquipmentType	Cranes	
tbOffRoadEquipment	OffRoadEquipmentType	Generator Sets	
tbOffRoadEquipment	OffRoadEquipmentType	Air Compressors	
tbOffRoadEquipment	OffRoadEquipmentUnitAmount	1.00	
tbOffRoadEquipment	OffRoadEquipmentUnitAmount	0.00	

BCTD DB-130 - San Francisco County, Annual

tbOffRoadEquipment	OffRoadEquipmentUnitAmount	0.00	1.00
tbOffRoadEquipment	OffRoadEquipmentUnitAmount	0.00	1.00
tbOffRoadEquipment	OffRoadEquipmentUnitAmount	0.00	1.00
tbOffRoadEquipment	OffRoadEquipmentUnitAmount	0.00	1.00
tbOffRoadEquipment	OffRoadEquipmentUnitAmount	0.00	1.00
tbOffRoadEquipment	OffRoadEquipmentUnitAmount	0.00	1.00
tbOffRoadEquipment	OffRoadEquipmentUnitAmount	0.00	1.00
tbOffRoadEquipment	OffRoadEquipmentUnitAmount	0.00	1.00
tbOffRoadEquipment	OffRoadEquipmentUnitAmount	0.00	1.00
tbOffRoadEquipment	OffRoadEquipmentUnitAmount	0.00	1.00
tbOffRoadEquipment	OffRoadEquipmentUnitAmount	0.00	1.00
tbOffRoadEquipment	OffRoadEquipmentUnitAmount	0.00	1.00
tbOffRoadEquipment	OffRoadEquipmentUnitAmount	0.00	1.00
tbOffRoadEquipment	OffRoadEquipmentUnitAmount	0.00	1.00
tbOffRoadEquipment	PhaseName		1:Site Excavation
tbOffRoadEquipment	PhaseName		1:Site Excavation
tbOffRoadEquipment	PhaseName		1:Site Excavation
tbOffRoadEquipment	PhaseName		1:Site Excavation
tbOffRoadEquipment	PhaseName		1:Site Excavation
tbOffRoadEquipment	PhaseName		2: Pile Driving
tbOffRoadEquipment	PhaseName		2: Pile Driving
tbOffRoadEquipment	PhaseName		2: Pile Driving
tbOffRoadEquipment	PhaseName		2: Pile Driving
tbOffRoadEquipment	PhaseName		3: Concrete Foundations
tbOffRoadEquipment	PhaseName		3: Concrete Foundations
tbOffRoadEquipment	PhaseName		4: Concrete Slabs
tbOffRoadEquipment	PhaseName		4: Concrete Slabs
tbOffRoadEquipment	PhaseName		4: Concrete Slabs
tbOffRoadEquipment	PhaseName		4: Concrete Slabs

BCTD DB-130 - San Francisco County, Annual

tbIOffRoadEquipment	PhaseName	5: Perimeter Wall	
tbIOffRoadEquipment	PhaseName	5: Perimeter Wall	
tbIOffRoadEquipment	PhaseName	5: Perimeter Wall	
tbIOffRoadEquipment	PhaseName	6: Backfill and Grading	
tbIOffRoadEquipment	PhaseName	6: Backfill and Grading	
tbIOffRoadEquipment	PhaseName	6: Backfill and Grading	
tbIOffRoadEquipment	PhaseName	6: Backfill and Grading	
tbIOffRoadEquipment	PhaseName	7: Electrical Equipment/Gate Install	
tbIOffRoadEquipment	PhaseName	7: Electrical Equipment/Gate Install	
tbIOffRoadEquipment	PhaseName	7: Electrical Equipment/Gate Install	
tbIOffRoadEquipment	PhaseName	7: Electrical Equipment/Gate Install	
tbIOffRoadEquipment	UsageHours	8.00	0.00
tbIOffRoadEquipment	UsageHours	4.00	0.00
tbIOffRoadEquipment	UsageHours	4.00	8.00
tbIOffRoadEquipment	UsageHours	8.00	0.00
tbIOffRoadEquipment	UsageHours	4.00	8.00
tbIOffRoadEquipment	UsageHours	6.00	0.00
tbIOffRoadEquipment	UsageHours	8.00	0.00
tbIOffRoadEquipment	UsageHours	6.00	0.00
tbIOffRoadEquipment	UsageHours	6.00	0.00
tbIOffRoadEquipment	UsageHours	1.00	0.00
tbIOffRoadEquipment	UsageHours	1.00	0.00
tbIOffRoadEquipment	UsageHours	6.00	0.00
tbIOffRoadEquipment	UsageHours	6.00	8.00
tblTripsAndVMT	VendorTripNumber	0.00	5.00
tblTripsAndVMT	VendorTripNumber	0.00	5.00
tblTripsAndVMT	WorkerTripNumber	15.00	26.00

BCTD DB-130 - San Francisco County, Annual

tblTripsAndVMT	WorkerTripNumber	10.00	20.00
tblTripsAndVMT	WorkerTripNumber	0.00	22.00
tblTripsAndVMT	WorkerTripNumber	0.00	26.00
tblTripsAndVMT	WorkerTripNumber	0.00	24.00
tblTripsAndVMT	WorkerTripNumber	13.00	24.00
tblTripsAndVMT	WorkerTripNumber	10.00	22.00

2.0 Emissions Summary

BCTD DB-130 - San Francisco County, Annual

2.1 Overall Construction

Unmitigated Construction

Year	tons/yr										MT/yr					
	ROG	NOx	CO	SO2	Fugitive PM10	Exhaust PM10	PM10 Total	Fugitive PM2.5	Exhaust PM2.5	PM2.5 Total	Bio- CO2	NBio- CO2	Total CO2	CH4	N2O	CO2e
2020	0.1194	1.1225	0.9322	2.1000e-003	0.0187	0.0534	0.0721	4.9500e-003	0.0513	0.0562	0.0000	185.7258	185.7258	0.0347	0.0000	186.5931
2021	0.0320	0.3352	0.2726	7.3000e-004	8.3400e-003	0.0130	0.0213	2.1900e-003	0.0124	0.0146	0.0000	67.0952	67.0952	0.0126	0.0000	67.4104
Maximum	0.1194	1.1225	0.9322	2.1000e-003	0.0187	0.0534	0.0721	4.9500e-003	0.0513	0.0562	0.0000	185.7258	185.7258	0.0347	0.0000	186.5931

Mitigated Construction

Year	tons/yr										MT/yr					
	ROG	NOx	CO	SO2	Fugitive PM10	Exhaust PM10	PM10 Total	Fugitive PM2.5	Exhaust PM2.5	PM2.5 Total	Bio- CO2	NBio- CO2	Total CO2	CH4	N2O	CO2e
2020	0.0220	0.1418	0.7514	2.1000e-003	0.0184	2.3100e-003	0.0207	4.9000e-003	2.3000e-003	7.2000e-003	0.0000	142.2047	142.2047	0.0322	0.0000	143.0107
2021	7.2800e-003	0.0947	0.2266	7.3000e-004	8.0300e-003	8.0000e-004	8.8300e-003	2.1400e-003	7.8000e-004	2.9300e-003	0.0000	55.2258	55.2258	0.0120	0.0000	55.5259
Maximum	0.0220	0.1418	0.7514	2.1000e-003	0.0184	2.3100e-003	0.0207	4.9000e-003	2.3000e-003	7.2000e-003	0.0000	142.2047	142.2047	0.0322	0.0000	143.0107

Percent Reduction	ROG	NOx	CO	SO2	Fugitive PM10	Exhaust PM10	PM10 Total	Fugitive PM2.5	Exhaust PM2.5	PM2.5 Total	Bio- CO2	NBio- CO2	Total CO2	CH4	N2O	CO2e
	80.64	83.77	18.82	0.00	2.37	95.31	68.39	1.40	95.17	85.70	0.00	21.91	21.91	6.47	0.00	21.84

BCTD DB-130 - San Francisco County, Annual

Quarter	Start Date	End Date	Maximum Unmitigated ROG + NOX (tons/quarter)	Maximum Mitigated ROG + NOX (tons/quarter)
1	6-1-2020	8-31-2020	0.5307	0.0856
2	9-1-2020	11-30-2020	0.5267	0.0570
3	12-1-2020	2-28-2021	0.5455	0.1232
4	3-1-2021	5-31-2021	0.0048	0.0003
		Highest	0.5455	0.1232

2.2 Overall Operational

Unmitigated Operational

Category	tons/yr										MT/yr						
	ROG	NOx	CO	SO2	Fugitive PM10	Exhaust PM10	PM10 Total	Fugitive PM2.5	Exhaust PM2.5	PM2.5 Total	Bio- CO2	NBio- CO2	Total CO2	CH4	N2O	CO2e	
Area	0.0000	0.0000	1.0000e-005	0.0000	0.0000	0.0000	0.0000	0.0000	0.0000	0.0000	0.0000	2.0000e-005	2.0000e-005	0.0000	0.0000	0.0000	2.0000e-005
Energy	0.0000	0.0000	0.0000	0.0000	0.0000	0.0000	0.0000	0.0000	0.0000	0.0000	0.0000	0.0000	0.0000	0.0000	0.0000	0.0000	0.0000
Mobile	0.0000	0.0000	0.0000	0.0000	0.0000	0.0000	0.0000	0.0000	0.0000	0.0000	0.0000	0.0000	0.0000	0.0000	0.0000	0.0000	0.0000
Waste																	
Water																	
Total	0.0000	0.0000	1.0000e-005	0.0000	0.0000	0.0000	0.0000	0.0000	0.0000	0.0000	0.0000	2.0000e-005	2.0000e-005	0.0000	0.0000	0.0000	2.0000e-005

BCTD DB-130 - San Francisco County, Annual

2.2 Overall Operational

Mitigated Operational

Category	tons/yr											MT/yr				
	ROG	NOx	CO	SO2	Fugitive PM10	Exhaust PM10	PM10 Total	Fugitive PM2.5	Exhaust PM2.5	PM2.5 Total	Bio- CO2	NBio- CO2	Total CO2	CH4	N2O	CO2e
Area	0.0000	0.0000	1.0000e-005	0.0000		0.0000	0.0000	0.0000	0.0000	0.0000	0.0000	2.0000e-005	2.0000e-005	0.0000	0.0000	2.0000e-005
Energy	0.0000	0.0000	0.0000	0.0000		0.0000	0.0000	0.0000	0.0000	0.0000	0.0000	0.0000	0.0000	0.0000	0.0000	0.0000
Mobile	0.0000	0.0000	0.0000	0.0000	0.0000	0.0000	0.0000	0.0000	0.0000	0.0000	0.0000	0.0000	0.0000	0.0000	0.0000	0.0000
Waste						0.0000	0.0000	0.0000	0.0000	0.0000	0.0000	0.0000	0.0000	0.0000	0.0000	0.0000
Water						0.0000	0.0000	0.0000	0.0000	0.0000	0.0000	0.0000	0.0000	0.0000	0.0000	0.0000
Total	0.0000	0.0000	1.0000e-005	0.0000	0.0000	0.0000	0.0000	0.0000	0.0000	0.0000	0.0000	2.0000e-005	2.0000e-005	0.0000	0.0000	2.0000e-005

Percent Reduction	tons/yr											MT/yr				
	ROG	NOx	CO	SO2	Fugitive PM10	Exhaust PM10	PM10 Total	Fugitive PM2.5	Exhaust PM2.5	PM2.5 Total	Bio- CO2	NBio- CO2	Total CO2	CH4	N2O	CO2e
0.00	0.00	0.00	0.00	0.00	0.00	0.00	0.00	0.00	0.00	0.00	0.00	0.00	0.00	0.00	0.00	0.00

3.0 Construction Detail

Construction Phase

BCTD DB-130 - San Francisco County, Annual

Phase Number	Phase Name	Phase Type	Start Date	End Date	Num Days Week	Num Days	Phase Description
1	1: Site Excavation	Site Preparation	6/1/2020	7/1/2020	5	23	
2	2: Pile Driving	Grading	7/2/2020	8/14/2020	5	32	
3	6: Backfill and Grading	Grading	1/2/2021	2/2/2021	5	22	
4	3: Concrete Foundations	Building Construction	8/15/2020	9/15/2020	5	22	
5	7: Electrical Equipment/Gate Install	Trenching	2/3/2021	3/1/2021	5	19	
6	4: Concrete Slabs	Building Construction	9/16/2020	11/9/2020	5	39	
7	5: Perimeter Wall	Building Construction	11/10/2020	1/1/2021	5	39	

Acres of Grading (Site Preparation Phase): 0

Acres of Grading (Grading Phase): 0

Acres of Paving: 0

Residential Indoor: 0; Residential Outdoor: 0; Non-Residential Indoor: 0; Non-Residential Outdoor: 0; Striped Parking Area: 0 (Architectural Coating – sqft)

OffRoad Equipment

Phase Name	Offroad Equipment Type	Amount	Usage Hours	Horse Power	Load Factor
6: Backfill and Grading	Concrete/Industrial Saws	0	0.00	81	0.73
4: Concrete Slabs	Cranes	0	0.00	231	0.29
5: Perimeter Wall	Cranes	1	8.00	231	0.29
2: Pile Driving	Concrete/Industrial Saws	0	0.00	81	0.73
3: Concrete Foundations	Cranes	1	8.00	231	0.29
3: Concrete Foundations	Forklifts	0	0.00	89	0.20
1: Site Excavation	Graders	0	0.00	187	0.41
4: Concrete Slabs	Forklifts	0	0.00	89	0.20
5: Perimeter Wall	Forklifts	0	0.00	89	0.20

BCTD DB-130 - San Francisco County, Annual

6: Backfill and Grading	Rubber Tired Dozers	0	0.00	247	0.40
2: Pile Driving	Rubber Tired Dozers	0	0.00	247	0.40
3: Concrete Foundations	Tractors/Loaders/Backhoes	1	8.00	97	0.37
4: Concrete Slabs	Tractors/Loaders/Backhoes	1	8.00	97	0.37
2: Pile Driving	Tractors/Loaders/Backhoes	0	0.00	97	0.37
5: Perimeter Wall	Tractors/Loaders/Backhoes	1	8.00	97	0.37
1: Site Excavation	Tractors/Loaders/Backhoes	1	8.00	97	0.37
6: Backfill and Grading	Tractors/Loaders/Backhoes	1	8.00	97	0.37
1: Site Excavation	Excavators	1	8.00	158	0.38
1: Site Excavation	Off-Highway Trucks	1	1.00	402	0.38
1: Site Excavation	Plate Compactors	1	2.00	8	0.43
1: Site Excavation	Generator Sets	1	8.00	84	0.74
1: Site Excavation	Air Compressors	1	8.00	78	0.48
2: Pile Driving	Bore/Drill Rigs	1	8.00	221	0.50
2: Pile Driving	Cranes	1	8.00	231	0.29
2: Pile Driving	Generator Sets	1	8.00	84	0.74
2: Pile Driving	Air Compressors	1	8.00	78	0.48
3: Concrete Foundations	Generator Sets	1	8.00	84	0.74
3: Concrete Foundations	Air Compressors	1	8.00	78	0.48
4: Concrete Slabs	Off-Highway Trucks	1	8.00	402	0.38
4: Concrete Slabs	Plate Compactors	1	8.00	8	0.43
4: Concrete Slabs	Generator Sets	1	8.00	84	0.74
4: Concrete Slabs	Air Compressors	1	8.00	78	0.48
5: Perimeter Wall	Plate Compactors	1	8.00	8	0.43
5: Perimeter Wall	Generator Sets	1	8.00	84	0.74
5: Perimeter Wall	Air Compressors	1	8.00	78	0.48
6: Backfill and Grading	Off-Highway Trucks	1	8.00	402	0.38

BCTD DB-130 - San Francisco County, Annual

6: Backfill and Grading	Plate Compactors	1	8.00	8	0.43
6: Backfill and Grading	Generator Sets	1	8.00	84	0.74
6: Backfill and Grading	Air Compressors	1	8.00	78	0.48
7: Electrical Equipment/Gate Install	Tractors/Loaders/Backhoes	1	8.00	97	0.37
7: Electrical Equipment/Gate Install	Cranes	1	8.00	231	0.29
7: Electrical Equipment/Gate Install	Generator Sets	1	8.00	84	0.74
7: Electrical Equipment/Gate Install	Air Compressors	1	8.00	78	0.48

Trips and VMT

Phase Name	Offroad Equipment Count	Worker Trip Number	Vendor Trip Number	Hauling Trip Number	Worker Trip Length	Vendor Trip Length	Hauling Trip Length	Worker Vehicle Class	Vendor Vehicle Class	Hauling Vehicle Class
4: Concrete Slabs	5	26.00	5.00	0.00	10.80	7.30	20.00	LD_Mix	HDT_Mix	HHDT
1: Site Excavation	6	26.00	0.00	291.00	10.80	7.30	20.00	LD_Mix	HDT_Mix	HHDT
2: Pile Driving	4	20.00	0.00	0.00	10.80	7.30	20.00	LD_Mix	HDT_Mix	HHDT
3: Concrete Foundations	4	22.00	0.00	0.00	10.80	7.30	20.00	LD_Mix	HDT_Mix	HHDT
5: Perimeter Wall	5	24.00	5.00	0.00	10.80	7.30	20.00	LD_Mix	HDT_Mix	HHDT
6: Backfill and Grading	5	24.00	0.00	469.00	10.80	7.30	20.00	LD_Mix	HDT_Mix	HHDT
7: Electrical Equipment/Gate Install	4	22.00	0.00	0.00	10.80	7.30	20.00	LD_Mix	HDT_Mix	HHDT

3.1 Mitigation Measures Construction

- Use Alternative Fuel for Construction Equipment
- Use Cleaner Engines for Construction Equipment
- Water Exposed Area

BCTD DB-130 - San Francisco County, Annual

3.2 1:Site Excavation - 2020
Unmitigated Construction On-Site

Category	tons/yr											MT/yr				
	ROG	NOx	CO	SO2	Fugitive PM10	Exhaust PM10	PM10 Total	Fugitive PM2.5	Exhaust PM2.5	PM2.5 Total	Bio- CO2	NBio- CO2	Total CO2	CH4	N2O	CO2e
Fugitive Dust					6.1000e-004	0.0000	6.1000e-004	8.0000e-005	0.0000	8.0000e-005	0.0000	0.0000	0.0000	0.0000	0.0000	0.0000
Off-Road	0.0146	0.1276	0.1406	2.4000e-004	7.1900e-003	7.1900e-003	6.9400e-003	6.9400e-003	6.9400e-003	6.9400e-003	0.0000	20.5276	20.5276	3.9200e-003	0.0000	20.6256
Total	0.0146	0.1276	0.1406	2.4000e-004	6.1000e-004	7.1900e-003	7.8000e-003	8.0000e-005	6.9400e-003	7.0200e-003	0.0000	20.5276	20.5276	3.9200e-003	0.0000	20.6256

Unmitigated Construction Off-Site

Category	tons/yr											MT/yr				
	ROG	NOx	CO	SO2	Fugitive PM10	Exhaust PM10	PM10 Total	Fugitive PM2.5	Exhaust PM2.5	PM2.5 Total	Bio- CO2	NBio- CO2	Total CO2	CH4	N2O	CO2e
Hauling	1.1600e-003	0.0507	0.0150	1.2000e-004	2.4400e-003	1.5000e-004	2.5900e-003	6.7000e-004	1.4000e-004	8.1000e-004	0.0000	12.9982	12.9982	2.3300e-003	0.0000	13.0564
Vendor	0.0000	0.0000	0.0000	0.0000	0.0000	0.0000	0.0000	0.0000	0.0000	0.0000	0.0000	0.0000	0.0000	0.0000	0.0000	0.0000
Worker	9.1000e-004	6.0000e-004	6.7200e-003	2.0000e-005	2.3600e-003	2.0000e-005	2.3800e-003	6.3000e-004	2.0000e-005	6.5000e-004	0.0000	2.2455	2.2455	5.0000e-005	0.0000	2.2467
Total	2.0700e-003	0.0513	0.0217	1.4000e-004	4.8000e-003	1.7000e-004	4.9700e-003	1.3000e-003	1.6000e-004	1.4600e-003	0.0000	15.2437	15.2437	2.3800e-003	0.0000	15.3031

BCTD DB-130 - San Francisco County, Annual

3.2 1:Site Excavation - 2020

Mitigated Construction On-Site

Category	tons/yr										MT/yr						
	ROG	NOx	CO	SO2	Fugitive PM10	Exhaust PM10	PM10 Total	Fugitive PM2.5	Exhaust PM2.5	PM2.5 Total	Bio- CO2	NBio- CO2	Total CO2	CH4	N2O	CO2e	
Fugitive Dust					2.7000e-004	0.0000	2.7000e-004	4.0000e-005	0.0000	4.0000e-005	0.0000	0.0000	0.0000	0.0000	0.0000	0.0000	0.0000
Off-Road	1.8600e-003	8.0400e-003	0.1086	2.4000e-004	2.5000e-004	2.5000e-004	2.5000e-004	2.5000e-004	2.5000e-004	2.5000e-004	0.0000	14.0277	14.0277	3.5500e-003	0.0000	0.0000	14.1165
Total	1.8600e-003	8.0400e-003	0.1086	2.4000e-004	2.7000e-004	2.5000e-004	5.2000e-004	4.0000e-005	2.5000e-004	2.9000e-004	0.0000	14.0277	14.0277	3.5500e-003	0.0000	0.0000	14.1165

Mitigated Construction Off-Site

Category	tons/yr										MT/yr						
	ROG	NOx	CO	SO2	Fugitive PM10	Exhaust PM10	PM10 Total	Fugitive PM2.5	Exhaust PM2.5	PM2.5 Total	Bio- CO2	NBio- CO2	Total CO2	CH4	N2O	CO2e	
Hauling	1.1600e-003	0.0507	0.0150	1.2000e-004	2.4400e-003	1.5000e-004	2.5900e-003	6.7000e-004	1.4000e-004	8.1000e-004	0.0000	12.9982	12.9982	2.3300e-003	0.0000	0.0000	13.0564
Vendor	0.0000	0.0000	0.0000	0.0000	0.0000	0.0000	0.0000	0.0000	0.0000	0.0000	0.0000	0.0000	0.0000	0.0000	0.0000	0.0000	0.0000
Worker	9.1000e-004	6.0000e-004	6.7200e-003	2.0000e-005	2.3600e-003	2.0000e-005	2.3800e-003	6.3000e-004	2.0000e-005	6.5000e-004	0.0000	2.2455	2.2455	5.0000e-005	0.0000	0.0000	2.2467
Total	2.0700e-003	0.0513	0.0217	1.4000e-004	4.8000e-003	1.7000e-004	4.9700e-003	1.3000e-003	1.6000e-004	1.4600e-003	0.0000	15.2437	15.2437	2.3800e-003	0.0000	0.0000	15.3031

BCTD DB-130 - San Francisco County, Annual

3.3.2: Pile Driving - 2020
Unmitigated Construction On-Site

Category	tons/yr											MT/yr				
	ROG	NOx	CO	SO2	Fugitive PM10	Exhaust PM10	PM10 Total	Fugitive PM2.5	Exhaust PM2.5	PM2.5 Total	Bio- CO2	NBio- CO2	Total CO2	CH4	N2O	CO2e
Fugitive Dust					0.0000	0.0000	0.0000	0.0000	0.0000	0.0000	0.0000	0.0000	0.0000	0.0000	0.0000	0.0000
Off-Road	0.0233	0.2342	0.1655	4.1000e-004	0.0107	0.0107	0.0107	0.0103	0.0103	0.0000	0.0000	35.8069	35.8069	7.8300e-003	0.0000	36.0025
Total	0.0233	0.2342	0.1655	4.1000e-004	0.0000	0.0107	0.0107	0.0103	0.0103	0.0000	0.0000	35.8069	35.8069	7.8300e-003	0.0000	36.0025

Unmitigated Construction Off-Site

Category	tons/yr											MT/yr				
	ROG	NOx	CO	SO2	Fugitive PM10	Exhaust PM10	PM10 Total	Fugitive PM2.5	Exhaust PM2.5	PM2.5 Total	Bio- CO2	NBio- CO2	Total CO2	CH4	N2O	CO2e
Hauling	0.0000	0.0000	0.0000	0.0000	0.0000	0.0000	0.0000	0.0000	0.0000	0.0000	0.0000	0.0000	0.0000	0.0000	0.0000	0.0000
Vendor	0.0000	0.0000	0.0000	0.0000	0.0000	0.0000	0.0000	0.0000	0.0000	0.0000	0.0000	0.0000	0.0000	0.0000	0.0000	0.0000
Worker	9.7000e-004	6.5000e-004	7.1900e-003	3.0000e-005	2.5300e-003	2.0000e-005	2.5500e-003	6.7000e-004	2.0000e-005	6.9000e-004	0.0000	2.4032	2.4032	5.0000e-005	0.0000	2.4045
Total	9.7000e-004	6.5000e-004	7.1900e-003	3.0000e-005	2.5300e-003	2.0000e-005	2.5500e-003	6.7000e-004	2.0000e-005	6.9000e-004	0.0000	2.4032	2.4032	5.0000e-005	0.0000	2.4045

BCTD DB-130 - San Francisco County, Annual

3.3.2: Pile Driving - 2020
Mitigated Construction On-Site

Category	tons/yr										MT/yr					
	ROG	NOx	CO	SO2	Fugitive PM10	Exhaust PM10	PM10 Total	Fugitive PM2.5	Exhaust PM2.5	PM2.5 Total	Bio- CO2	NBio- CO2	Total CO2	CH4	N2O	CO2e
Fugitive Dust					0.0000	0.0000	0.0000	0.0000	0.0000	0.0000	0.0000	0.0000	0.0000	0.0000	0.0000	0.0000
Off-Road	3.6400e-003	0.0158	0.1493	4.1000e-004	4.9000e-004	4.9000e-004	4.9000e-004	4.9000e-004	4.9000e-004	4.9000e-004	0.0000	26.7635	26.7635	7.3200e-003	0.0000	26.9464
Total	3.6400e-003	0.0158	0.1493	4.1000e-004	0.0000	4.9000e-004	4.9000e-004	0.0000	4.9000e-004	4.9000e-004	0.0000	26.7635	26.7635	7.3200e-003	0.0000	26.9464

Mitigated Construction Off-Site

Category	tons/yr										MT/yr					
	ROG	NOx	CO	SO2	Fugitive PM10	Exhaust PM10	PM10 Total	Fugitive PM2.5	Exhaust PM2.5	PM2.5 Total	Bio- CO2	NBio- CO2	Total CO2	CH4	N2O	CO2e
Hauling	0.0000	0.0000	0.0000	0.0000	0.0000	0.0000	0.0000	0.0000	0.0000	0.0000	0.0000	0.0000	0.0000	0.0000	0.0000	0.0000
Vendor	0.0000	0.0000	0.0000	0.0000	0.0000	0.0000	0.0000	0.0000	0.0000	0.0000	0.0000	0.0000	0.0000	0.0000	0.0000	0.0000
Worker	9.7000e-004	6.5000e-004	7.1900e-003	3.0000e-005	2.5300e-003	2.0000e-005	2.5500e-003	6.7000e-004	2.0000e-005	6.9000e-004	0.0000	2.4032	2.4032	5.0000e-005	0.0000	2.4045
Total	9.7000e-004	6.5000e-004	7.1900e-003	3.0000e-005	2.5300e-003	2.0000e-005	2.5500e-003	6.7000e-004	2.0000e-005	6.9000e-004	0.0000	2.4032	2.4032	5.0000e-005	0.0000	2.4045

BCTD DB-130 - San Francisco County, Annual

3.4 6: Backfill and Grading - 2021

Unmitigated Construction On-Site

Category	tons/yr											MT/yr				
	ROG	NOx	CO	SO2	Fugitive PM10	Exhaust PM10	PM10 Total	Fugitive PM2.5	Exhaust PM2.5	PM2.5 Total	Bio- CO2	NBio- CO2	Total CO2	CH4	N2O	CO2e
Fugitive Dust					5.5000e-004	0.0000	5.5000e-004	8.0000e-005	0.0000	8.0000e-005	0.0000	0.0000	0.0000	0.0000	0.0000	0.0000
Off-Road	0.0163	0.1387	0.1340	3.0000e-004	6.6900e-003	6.6900e-003	6.6900e-003	6.4200e-003	6.4200e-003	6.4200e-003	0.0000	26.0672	26.0672	5.7100e-003	0.0000	26.2099
Total	0.0163	0.1387	0.1340	3.0000e-004	5.5000e-004	6.6900e-003	7.2400e-003	8.0000e-005	6.4200e-003	6.5000e-003	0.0000	26.0672	26.0672	5.7100e-003	0.0000	26.2099

Unmitigated Construction Off-Site

Category	tons/yr											MT/yr				
	ROG	NOx	CO	SO2	Fugitive PM10	Exhaust PM10	PM10 Total	Fugitive PM2.5	Exhaust PM2.5	PM2.5 Total	Bio- CO2	NBio- CO2	Total CO2	CH4	N2O	CO2e
Hauling	1.7800e-003	0.0757	0.0248	1.9000e-004	3.9300e-003	2.2000e-004	4.1500e-003	1.0800e-003	2.1000e-004	1.2900e-003	0.0000	20.5768	20.5768	3.7700e-003	0.0000	20.6712
Vendor	0.0000	0.0000	0.0000	0.0000	0.0000	0.0000	0.0000	0.0000	0.0000	0.0000	0.0000	0.0000	0.0000	0.0000	0.0000	0.0000
Worker	7.5000e-004	4.8000e-004	5.4900e-003	2.0000e-005	2.0900e-003	2.0000e-005	2.1000e-003	5.5000e-004	1.0000e-005	5.7000e-004	0.0000	1.9118	1.9118	4.0000e-005	0.0000	1.9128
Total	2.5300e-003	0.0762	0.0303	2.1000e-004	6.0200e-003	2.4000e-004	6.2500e-003	1.6300e-003	2.2000e-004	1.8600e-003	0.0000	22.4886	22.4886	3.8100e-003	0.0000	22.5840

BCTD DB-130 - San Francisco County, Annual

3.4 6: Backfill and Grading - 2021

Mitigated Construction On-Site

Category	tons/yr										MT/yr					
	ROG	NOx	CO	SO2	Fugitive PM10	Exhaust PM10	PM10 Total	Fugitive PM2.5	Exhaust PM2.5	PM2.5 Total	Bio- CO2	NBio- CO2	Total CO2	CH4	N2O	CO2e
Fugitive Dust					2.5000e-004	0.0000	2.5000e-004	4.0000e-005	0.0000	4.0000e-005	0.0000	0.0000	0.0000	0.0000	0.0000	0.0000
Off-Road	2.6300e-003	0.0114	0.1178	3.0000e-004	3.5000e-004	3.5000e-004	3.5000e-004	3.5000e-004	3.5000e-004	3.5000e-004	0.0000	19.8499	19.8499	5.3900e-003	0.0000	19.9847
Total	2.6300e-003	0.0114	0.1178	3.0000e-004	2.5000e-004	3.5000e-004	6.0000e-004	4.0000e-005	3.5000e-004	3.9000e-004	0.0000	19.8499	19.8499	5.3900e-003	0.0000	19.9847

Mitigated Construction Off-Site

Category	tons/yr										MT/yr					
	ROG	NOx	CO	SO2	Fugitive PM10	Exhaust PM10	PM10 Total	Fugitive PM2.5	Exhaust PM2.5	PM2.5 Total	Bio- CO2	NBio- CO2	Total CO2	CH4	N2O	CO2e
Hauling	1.7800e-003	0.0757	0.0248	1.9000e-004	3.9300e-003	2.2000e-004	4.1500e-003	1.0800e-003	2.1000e-004	1.2900e-003	0.0000	20.5768	20.5768	3.7700e-003	0.0000	20.6712
Vendor	0.0000	0.0000	0.0000	0.0000	0.0000	0.0000	0.0000	0.0000	0.0000	0.0000	0.0000	0.0000	0.0000	0.0000	0.0000	0.0000
Worker	7.5000e-004	4.8000e-004	5.4900e-003	2.0000e-005	2.0900e-003	2.0000e-005	2.1000e-003	5.5000e-004	1.0000e-005	5.7000e-004	0.0000	1.9118	1.9118	4.0000e-005	0.0000	1.9128
Total	2.5300e-003	0.0762	0.0303	2.1000e-004	6.0200e-003	2.4000e-004	6.2500e-003	1.6300e-003	2.2000e-004	1.8600e-003	0.0000	22.4886	22.4886	3.8100e-003	0.0000	22.5840

BCTD DB-130 - San Francisco County, Annual

3.5.3: Concrete Foundations - 2020
Unmitigated Construction On-Site

Category	tons/yr											MT/yr				
	ROG	NOx	CO	SO2	Fugitive PM10	Exhaust PM10	PM10 Total	Fugitive PM2.5	Exhaust PM2.5	PM2.5 Total	Bio- CO2	NBio- CO2	Total CO2	CH4	N2O	CO2e
Off-Road	0.0152	0.1454	0.1160	2.1000e-004	7.6900e-003	7.6900e-003	7.6900e-003	7.3800e-003	7.3800e-003	7.3800e-003	0.0000	18.5396	18.5396	3.4100e-003	0.0000	18.6250
Total	0.0152	0.1454	0.1160	2.1000e-004	7.6900e-003	7.6900e-003	7.6900e-003	7.3800e-003	7.3800e-003	7.3800e-003	0.0000	18.5396	18.5396	3.4100e-003	0.0000	18.6250

Unmitigated Construction Off-Site

Category	tons/yr											MT/yr				
	ROG	NOx	CO	SO2	Fugitive PM10	Exhaust PM10	PM10 Total	Fugitive PM2.5	Exhaust PM2.5	PM2.5 Total	Bio- CO2	NBio- CO2	Total CO2	CH4	N2O	CO2e
Hauling	0.0000	0.0000	0.0000	0.0000	0.0000	0.0000	0.0000	0.0000	0.0000	0.0000	0.0000	0.0000	0.0000	0.0000	0.0000	0.0000
Vendor	0.0000	0.0000	0.0000	0.0000	0.0000	0.0000	0.0000	0.0000	0.0000	0.0000	0.0000	0.0000	0.0000	0.0000	0.0000	0.0000
Worker	7.4000e-004	4.9000e-004	5.4400e-003	2.0000e-005	1.9100e-003	1.0000e-005	1.9300e-003	5.1000e-004	1.0000e-005	5.2000e-004	0.0000	1.8174	1.8174	4.0000e-005	0.0000	1.8184
Total	7.4000e-004	4.9000e-004	5.4400e-003	2.0000e-005	1.9100e-003	1.0000e-005	1.9300e-003	5.1000e-004	1.0000e-005	5.2000e-004	0.0000	1.8174	1.8174	4.0000e-005	0.0000	1.8184

BCTD DB-130 - San Francisco County, Annual

3.5 3: Concrete Foundations - 2020

Mitigated Construction On-Site

Category	tons/yr										MT/yr					
	ROG	NOx	CO	SO2	Fugitive PM10	Exhaust PM10	PM10 Total	Fugitive PM2.5	Exhaust PM2.5	PM2.5 Total	Bio- CO2	NBio- CO2	Total CO2	CH4	N2O	CO2e
Off-Road	1.6300e-003	7.0800e-003	0.0812	2.1000e-004	2.2000e-004	2.2000e-004	2.2000e-004	2.2000e-004	2.2000e-004	2.2000e-004	0.0000	12.3223	12.3223	3.0600e-003	0.0000	12.3989
Total	1.6300e-003	7.0800e-003	0.0812	2.1000e-004	2.2000e-004	2.2000e-004	2.2000e-004	2.2000e-004	2.2000e-004	2.2000e-004	0.0000	12.3223	12.3223	3.0600e-003	0.0000	12.3989

Mitigated Construction Off-Site

Category	tons/yr										MT/yr					
	ROG	NOx	CO	SO2	Fugitive PM10	Exhaust PM10	PM10 Total	Fugitive PM2.5	Exhaust PM2.5	PM2.5 Total	Bio- CO2	NBio- CO2	Total CO2	CH4	N2O	CO2e
Hauling	0.0000	0.0000	0.0000	0.0000	0.0000	0.0000	0.0000	0.0000	0.0000	0.0000	0.0000	0.0000	0.0000	0.0000	0.0000	0.0000
Vendor	0.0000	0.0000	0.0000	0.0000	0.0000	0.0000	0.0000	0.0000	0.0000	0.0000	0.0000	0.0000	0.0000	0.0000	0.0000	0.0000
Worker	7.4000e-004	4.9000e-004	5.4400e-003	2.0000e-005	1.9100e-003	1.0000e-005	1.9300e-003	5.1000e-004	1.0000e-005	5.2000e-004	0.0000	1.8174	1.8174	4.0000e-005	0.0000	1.8184
Total	7.4000e-004	4.9000e-004	5.4400e-003	2.0000e-005	1.9100e-003	1.0000e-005	1.9300e-003	5.1000e-004	1.0000e-005	5.2000e-004	0.0000	1.8174	1.8174	4.0000e-005	0.0000	1.8184

BCTD DB-130 - San Francisco County, Annual

3.6.7: Electrical Equipment/Gate Install - 2021

Unmitigated Construction On-Site

Category	tons/yr											MT/yr				
	ROG	NOx	CO	SO2	Fugitive PM10	Exhaust PM10	PM10 Total	Fugitive PM2.5	Exhaust PM2.5	PM2.5 Total	Bio- CO2	NBio- CO2	Total CO2	CH4	N2O	CO2e
Off-Road	0.0119	0.1135	0.0983	1.8000e-004	5.7200e-003	5.7200e-003	5.7200e-003	5.4800e-003	5.4800e-003	5.4800e-003	0.0000	16.0122	16.0122	2.8900e-003	0.0000	16.0845
Total	0.0119	0.1135	0.0983	1.8000e-004	5.7200e-003	5.7200e-003	5.7200e-003	5.4800e-003	5.4800e-003	5.4800e-003	0.0000	16.0122	16.0122	2.8900e-003	0.0000	16.0845

Unmitigated Construction Off-Site

Category	tons/yr											MT/yr				
	ROG	NOx	CO	SO2	Fugitive PM10	Exhaust PM10	PM10 Total	Fugitive PM2.5	Exhaust PM2.5	PM2.5 Total	Bio- CO2	NBio- CO2	Total CO2	CH4	N2O	CO2e
Hauling	0.0000	0.0000	0.0000	0.0000	0.0000	0.0000	0.0000	0.0000	0.0000	0.0000	0.0000	0.0000	0.0000	0.0000	0.0000	0.0000
Vendor	0.0000	0.0000	0.0000	0.0000	0.0000	0.0000	0.0000	0.0000	0.0000	0.0000	0.0000	0.0000	0.0000	0.0000	0.0000	0.0000
Worker	5.9000e-004	3.8000e-004	4.3400e-003	2.0000e-005	1.6500e-003	1.0000e-005	1.6600e-003	4.4000e-004	1.0000e-005	4.5000e-004	0.0000	1.5135	1.5135	3.0000e-005	0.0000	1.5143
Total	5.9000e-004	3.8000e-004	4.3400e-003	2.0000e-005	1.6500e-003	1.0000e-005	1.6600e-003	4.4000e-004	1.0000e-005	4.5000e-004	0.0000	1.5135	1.5135	3.0000e-005	0.0000	1.5143

BCTD DB-130 - San Francisco County, Annual

3.6 7: Electrical Equipment/Gate Install - 2021

Mitigated Construction On-Site

Category	tons/yr											MT/yr				
	ROG	NOx	CO	SO2	Fugitive PM10	Exhaust PM10	PM10 Total	Fugitive PM2.5	Exhaust PM2.5	PM2.5 Total	Bio- CO2	NBio- CO2	Total CO2	CH4	N2O	CO2e
Off-Road	1.4100e-003	6.1100e-003	0.0702	1.8000e-004	1.9000e-004	1.9000e-004	1.9000e-004	1.9000e-004	1.9000e-004	1.9000e-004	0.0000	10.6427	10.6427	2.6200e-003	0.0000	10.7082
Total	1.4100e-003	6.1100e-003	0.0702	1.8000e-004	1.9000e-004	1.9000e-004	1.9000e-004	1.9000e-004	1.9000e-004	1.9000e-004	0.0000	10.6427	10.6427	2.6200e-003	0.0000	10.7082

Mitigated Construction Off-Site

Category	tons/yr											MT/yr				
	ROG	NOx	CO	SO2	Fugitive PM10	Exhaust PM10	PM10 Total	Fugitive PM2.5	Exhaust PM2.5	PM2.5 Total	Bio- CO2	NBio- CO2	Total CO2	CH4	N2O	CO2e
Hauling	0.0000	0.0000	0.0000	0.0000	0.0000	0.0000	0.0000	0.0000	0.0000	0.0000	0.0000	0.0000	0.0000	0.0000	0.0000	0.0000
Vendor	0.0000	0.0000	0.0000	0.0000	0.0000	0.0000	0.0000	0.0000	0.0000	0.0000	0.0000	0.0000	0.0000	0.0000	0.0000	0.0000
Worker	5.9000e-004	3.8000e-004	4.3400e-003	2.0000e-005	1.6500e-003	1.0000e-005	1.6600e-003	4.4000e-004	1.0000e-005	4.5000e-004	0.0000	1.5135	1.5135	3.0000e-005	0.0000	1.5143
Total	5.9000e-004	3.8000e-004	4.3400e-003	2.0000e-005	1.6500e-003	1.0000e-005	1.6600e-003	4.4000e-004	1.0000e-005	4.5000e-004	0.0000	1.5135	1.5135	3.0000e-005	0.0000	1.5143

BCTD DB-130 - San Francisco County, Annual

3.7 4: Concrete Slabs - 2020
Unmitigated Construction On-Site

Category	tons/yr											MT/yr				
	ROG	NOx	CO	SO2	Fugitive PM10	Exhaust PM10	PM10 Total	Fugitive PM2.5	Exhaust PM2.5	PM2.5 Total	Bio- CO2	NBio- CO2	Total CO2	CH4	N2O	CO2e
Off-Road	0.0319	0.2809	0.2427	5.3000e-004		0.0140	0.0140		0.0134	0.0134	0.0000	46.2095	46.2095	0.0102	0.0000	46.4654
Total	0.0319	0.2809	0.2427	5.3000e-004		0.0140	0.0140		0.0134	0.0134	0.0000	46.2095	46.2095	0.0102	0.0000	46.4654

Unmitigated Construction Off-Site

Category	tons/yr											MT/yr				
	ROG	NOx	CO	SO2	Fugitive PM10	Exhaust PM10	PM10 Total	Fugitive PM2.5	Exhaust PM2.5	PM2.5 Total	Bio- CO2	NBio- CO2	Total CO2	CH4	N2O	CO2e
Hauling	0.0000	0.0000	0.0000	0.0000	0.0000	0.0000	0.0000	0.0000	0.0000	0.0000	0.0000	0.0000	0.0000	0.0000	0.0000	0.0000
Vendor	3.6000e-004	0.0122	3.6100e-003	3.0000e-005	6.4000e-004	5.0000e-005	6.9000e-004	1.8000e-004	5.0000e-005	2.4000e-004	0.0000	2.6989	2.6989	3.6000e-004	0.0000	2.7079
Worker	1.5400e-003	1.0300e-003	0.0114	4.0000e-005	4.0100e-003	3.0000e-005	4.0400e-003	1.0700e-003	3.0000e-005	1.0900e-003	0.0000	3.8075	3.8075	8.0000e-005	0.0000	3.8096
Total	1.9000e-003	0.0132	0.0150	7.0000e-005	4.6500e-003	8.0000e-005	4.7300e-003	1.2500e-003	8.0000e-005	1.3300e-003	0.0000	6.5064	6.5064	4.4000e-004	0.0000	6.5175

BCTD DB-130 - San Francisco County, Annual

3.7 4: Concrete Slabs - 2020
Mitigated Construction On-Site

Category	tons/yr										MT/yr					
	ROG	NOx	CO	SO2	Fugitive PM10	Exhaust PM10	PM10 Total	Fugitive PM2.5	Exhaust PM2.5	PM2.5 Total	Bio- CO2	NBio- CO2	Total CO2	CH4	N2O	CO2e
Off-Road	4.6700e-003	0.0202	0.2089	5.3000e-004	6.2000e-004	6.2000e-004	6.2000e-004	6.2000e-004	6.2000e-004	6.2000e-004	0.0000	35.1879	35.1879	9.6100e-003	0.0000	35.4283
Total	4.6700e-003	0.0202	0.2089	5.3000e-004	6.2000e-004	6.2000e-004	6.2000e-004	6.2000e-004	6.2000e-004	6.2000e-004	0.0000	35.1879	35.1879	9.6100e-003	0.0000	35.4283

Mitigated Construction Off-Site

Category	tons/yr										MT/yr					
	ROG	NOx	CO	SO2	Fugitive PM10	Exhaust PM10	PM10 Total	Fugitive PM2.5	Exhaust PM2.5	PM2.5 Total	Bio- CO2	NBio- CO2	Total CO2	CH4	N2O	CO2e
Hauling	0.0000	0.0000	0.0000	0.0000	0.0000	0.0000	0.0000	0.0000	0.0000	0.0000	0.0000	0.0000	0.0000	0.0000	0.0000	0.0000
Vendor	3.6000e-004	0.0122	3.6100e-003	3.0000e-005	6.4000e-004	5.0000e-005	6.9000e-004	1.8000e-004	5.0000e-005	2.4000e-004	0.0000	2.6989	2.6989	3.6000e-004	0.0000	2.7079
Worker	1.5400e-003	1.0300e-003	0.0114	4.0000e-005	4.0100e-003	3.0000e-005	4.0400e-003	1.0700e-003	3.0000e-005	1.0900e-003	0.0000	3.8075	3.8075	8.0000e-005	0.0000	3.8096
Total	1.9000e-003	0.0132	0.0150	7.0000e-005	4.6500e-003	8.0000e-005	4.7300e-003	1.2500e-003	8.0000e-005	1.3300e-003	0.0000	6.5064	6.5064	4.4000e-004	0.0000	6.5175

BCTD DB-130 - San Francisco County, Annual

3.8.5: Perimeter Wall - 2020
Unmitigated Construction On-Site

Category	tons/yr											MT/yr				
	ROG	NOx	CO	SO2	Fugitive PM10	Exhaust PM10	PM10 Total	Fugitive PM2.5	Exhaust PM2.5	PM2.5 Total	Bio- CO2	NBio- CO2	Total CO2	CH4	N2O	CO2e
Off-Road	0.0271	0.2560	0.2043	3.8000e-004		0.0135	0.0135		0.0129	0.0129	0.0000	32.6173	32.6173	5.9600e-003	0.0000	32.7662
Total	0.0271	0.2560	0.2043	3.8000e-004		0.0135	0.0135		0.0129	0.0129	0.0000	32.6173	32.6173	5.9600e-003	0.0000	32.7662

Unmitigated Construction Off-Site

Category	tons/yr											MT/yr				
	ROG	NOx	CO	SO2	Fugitive PM10	Exhaust PM10	PM10 Total	Fugitive PM2.5	Exhaust PM2.5	PM2.5 Total	Bio- CO2	NBio- CO2	Total CO2	CH4	N2O	CO2e
Hauling	0.0000	0.0000	0.0000	0.0000	0.0000	0.0000	0.0000	0.0000	0.0000	0.0000	0.0000	0.0000	0.0000	0.0000	0.0000	0.0000
Vendor	3.5000e-004	0.0119	3.5100e-003	3.0000e-005	6.2000e-004	5.0000e-005	6.7000e-004	1.8000e-004	5.0000e-005	2.3000e-004	0.0000	2.6297	2.6297	3.5000e-004	0.0000	2.6385
Worker	1.3900e-003	9.2000e-004	0.0103	4.0000e-005	3.6000e-003	3.0000e-005	3.6300e-003	9.6000e-004	3.0000e-005	9.8000e-004	0.0000	3.4245	3.4245	8.0000e-005	0.0000	3.4264
Total	1.7400e-003	0.0128	0.0138	7.0000e-005	4.2200e-003	8.0000e-005	4.3000e-003	1.1400e-003	8.0000e-005	1.2100e-003	0.0000	6.0542	6.0542	4.3000e-004	0.0000	6.0649

BCTD DB-130 - San Francisco County, Annual

3.8.5: Perimeter Wall - 2020
Mitigated Construction On-Site

Category	tons/yr											MT/yr				
	ROG	NOx	CO	SO2	Fugitive PM10	Exhaust PM10	PM10 Total	Fugitive PM2.5	Exhaust PM2.5	PM2.5 Total	Bio- CO2	NBio- CO2	Total CO2	CH4	N2O	CO2e
Off-Road	2.8200e-003	0.0122	0.1403	3.8000e-004	3.8000e-004	3.8000e-004	3.8000e-004	3.8000e-004	3.8000e-004	3.8000e-004	0.0000	21.8783	21.8783	5.3500e-003	0.0000	22.0122
Total	2.8200e-003	0.0122	0.1403	3.8000e-004	3.8000e-004	3.8000e-004	3.8000e-004	3.8000e-004	3.8000e-004	3.8000e-004	0.0000	21.8783	21.8783	5.3500e-003	0.0000	22.0122

Mitigated Construction Off-Site

Category	tons/yr											MT/yr				
	ROG	NOx	CO	SO2	Fugitive PM10	Exhaust PM10	PM10 Total	Fugitive PM2.5	Exhaust PM2.5	PM2.5 Total	Bio- CO2	NBio- CO2	Total CO2	CH4	N2O	CO2e
Hauling	0.0000	0.0000	0.0000	0.0000	0.0000	0.0000	0.0000	0.0000	0.0000	0.0000	0.0000	0.0000	0.0000	0.0000	0.0000	0.0000
Vendor	3.5000e-004	0.0119	3.5100e-003	3.0000e-005	6.2000e-004	5.0000e-005	6.7000e-004	1.8000e-004	5.0000e-005	2.3000e-004	0.0000	2.6297	2.6297	3.5000e-004	0.0000	2.6385
Worker	1.3900e-003	9.2000e-004	0.0103	4.0000e-005	3.6000e-003	3.0000e-005	3.6300e-003	9.6000e-004	3.0000e-005	9.8000e-004	0.0000	3.4245	3.4245	8.0000e-005	0.0000	3.4264
Total	1.7400e-003	0.0128	0.0138	7.0000e-005	4.2200e-003	8.0000e-005	4.3000e-003	1.1400e-003	8.0000e-005	1.2100e-003	0.0000	6.0542	6.0542	4.3000e-004	0.0000	6.0649

BCTD DB-130 - San Francisco County, Annual

3.8.5: Perimeter Wall - 2021
Unmitigated Construction On-Site

Category	tons/yr											MT/yr				
	ROG	NOx	CO	SO2	Fugitive PM10	Exhaust PM10	PM10 Total	Fugitive PM2.5	Exhaust PM2.5	PM2.5 Total	Bio- CO2	NBio- CO2	Total CO2	CH4	N2O	CO2e
Off-Road	6.4000e-004	6.1000e-003	5.2800e-003	1.0000e-005	3.1000e-004	3.1000e-004	3.1000e-004	2.9000e-004	2.9000e-004	2.9000e-004	0.0000	0.8584	0.8584	1.5000e-004	0.0000	0.8622
Total	6.4000e-004	6.1000e-003	5.2800e-003	1.0000e-005	3.1000e-004	3.1000e-004	3.1000e-004	2.9000e-004	2.9000e-004	2.9000e-004	0.0000	0.8584	0.8584	1.5000e-004	0.0000	0.8622

Unmitigated Construction Off-Site

Category	tons/yr											MT/yr				
	ROG	NOx	CO	SO2	Fugitive PM10	Exhaust PM10	PM10 Total	Fugitive PM2.5	Exhaust PM2.5	PM2.5 Total	Bio- CO2	NBio- CO2	Total CO2	CH4	N2O	CO2e
Hauling	0.0000	0.0000	0.0000	0.0000	0.0000	0.0000	0.0000	0.0000	0.0000	0.0000	0.0000	0.0000	0.0000	0.0000	0.0000	0.0000
Vendor	1.0000e-005	2.9000e-004	9.0000e-005	0.0000	2.0000e-005	0.0000	2.0000e-005	0.0000	0.0000	1.0000e-005	0.0000	0.0683	0.0683	1.0000e-005	0.0000	0.0686
Worker	3.0000e-005	2.0000e-005	2.5000e-004	0.0000	9.0000e-005	0.0000	1.0000e-004	3.0000e-005	0.0000	3.0000e-005	0.0000	0.0869	0.0869	0.0000	0.0000	0.0870
Total	4.0000e-005	3.1000e-004	3.4000e-004	0.0000	1.1000e-004	0.0000	1.2000e-004	3.0000e-005	0.0000	4.0000e-005	0.0000	0.1552	0.1552	1.0000e-005	0.0000	0.1555

BCTD DB-130 - San Francisco County, Annual

3.8 5: Perimeter Wall - 2021
Mitigated Construction On-Site

Category	tons/yr											MT/yr				
	ROG	NOx	CO	SO2	Fugitive PM10	Exhaust PM10	PM10 Total	Fugitive PM2.5	Exhaust PM2.5	PM2.5 Total	Bio- CO2	NBio- CO2	Total CO2	CH4	N2O	CO2e
Off-Road	7.0000e-005	3.2000e-004	3.6900e-003	1.0000e-005	1.0000e-005	1.0000e-005	1.0000e-005	1.0000e-005	1.0000e-005	1.0000e-005	0.0000	0.5758	0.5758	1.4000e-004	0.0000	0.5793
Total	7.0000e-005	3.2000e-004	3.6900e-003	1.0000e-005	1.0000e-005	1.0000e-005	1.0000e-005	1.0000e-005	1.0000e-005	1.0000e-005	0.0000	0.5758	0.5758	1.4000e-004	0.0000	0.5793

Mitigated Construction Off-Site

Category	tons/yr											MT/yr				
	ROG	NOx	CO	SO2	Fugitive PM10	Exhaust PM10	PM10 Total	Fugitive PM2.5	Exhaust PM2.5	PM2.5 Total	Bio- CO2	NBio- CO2	Total CO2	CH4	N2O	CO2e
Hauling	0.0000	0.0000	0.0000	0.0000	0.0000	0.0000	0.0000	0.0000	0.0000	0.0000	0.0000	0.0000	0.0000	0.0000	0.0000	0.0000
Vendor	1.0000e-005	2.9000e-004	9.0000e-005	0.0000	2.0000e-005	0.0000	2.0000e-005	0.0000	0.0000	1.0000e-005	0.0000	0.0683	0.0683	1.0000e-005	0.0000	0.0686
Worker	3.0000e-005	2.0000e-005	2.5000e-004	0.0000	9.0000e-005	0.0000	1.0000e-004	3.0000e-005	0.0000	3.0000e-005	0.0000	0.0869	0.0869	0.0000	0.0000	0.0870
Total	4.0000e-005	3.1000e-004	3.4000e-004	0.0000	1.1000e-004	0.0000	1.2000e-004	3.0000e-005	0.0000	4.0000e-005	0.0000	0.1552	0.1552	1.0000e-005	0.0000	0.1555

4.0 Operational Detail - Mobile

BCTD DB-130 - San Francisco County, Annual

4.1 Mitigation Measures Mobile

Category	tons/yr										MT/yr					
	ROG	NOx	CO	SO2	Fugitive PM10	Exhaust PM10	PM10 Total	Fugitive PM2.5	Exhaust PM2.5	PM2.5 Total	Bio- CO2	NBio- CO2	Total CO2	CH4	N2O	CO2e
Mitigated	0.0000	0.0000	0.0000	0.0000	0.0000	0.0000	0.0000	0.0000	0.0000	0.0000	0.0000	0.0000	0.0000	0.0000	0.0000	0.0000
Unmitigated	0.0000	0.0000	0.0000	0.0000	0.0000	0.0000	0.0000	0.0000	0.0000	0.0000	0.0000	0.0000	0.0000	0.0000	0.0000	0.0000

4.2 Trip Summary Information

Land Use	Average Daily Trip Rate			Unmitigated Annual VMT	Mitigated Annual VMT
	Weekday	Saturday	Sunday		
User Defined Industrial	0.00	0.00	0.00		
Total	0.00	0.00	0.00		

4.3 Trip Type Information

Land Use	Miles				Trip %				Trip Purpose %			
	H-W or C-W	H-O or C-NW	H-S or C-C	H-O or C-NW	H-W or C-W	H-S or C-C	H-O or C-NW	H-O or C-NW	Primary	Diverted	Pass-by	
User Defined Industrial	9.50	7.30	7.30	7.30	0.00	0.00	0.00	0.00	0	0	0	

4.4 Fleet Mix

Land Use	LDA	LDT1	LDT2	MDV	LHD1	LHD2	MHD	HHD	OBUS	UBUS	MCY	SBUS	MH
User Defined Industrial	0.606408	0.040118	0.191445	0.088323	0.014900	0.004926	0.028280	0.008891	0.004289	0.004272	0.006741	0.000931	0.000477

BCTD DB-130 - San Francisco County, Annual

5.3 Energy by Land Use - Electricity

Unmitigated

Land Use	Electricity Use	Total CO2	CH4	N2O	CO2e
	kWh/yr	MT/yr			
User Defined Industrial	0	0.0000	0.0000	0.0000	0.0000
Total		0.0000	0.0000	0.0000	0.0000

Mitigated

Land Use	Electricity Use	Total CO2	CH4	N2O	CO2e
	kWh/yr	MT/yr			
User Defined Industrial	0	0.0000	0.0000	0.0000	0.0000
Total		0.0000	0.0000	0.0000	0.0000

6.0 Area Detail

6.1 Mitigation Measures Area

BCTD DB-130 - San Francisco County, Annual

Category	ROG	NOx	CO	SO2	Fugitive PM10	Exhaust PM10	PM10 Total	Fugitive PM2.5	Exhaust PM2.5	PM2.5 Total	Bio- CO2	NBio- CO2	Total CO2	CH4	N2O	CO2e	
tons/yr																	
MT/yr																	
Mitigated	0.0000	0.0000	1.0000e-005	0.0000	0.0000	0.0000	0.0000	0.0000	0.0000	0.0000	0.0000	2.0000e-005	2.0000e-005	0.0000	0.0000	0.0000	2.0000e-005
Unmitigated	0.0000	0.0000	1.0000e-005	0.0000	0.0000	0.0000	0.0000	0.0000	0.0000	0.0000	0.0000	2.0000e-005	2.0000e-005	0.0000	0.0000	0.0000	2.0000e-005

6.2 Area by SubCategory

Unmitigated

SubCategory	ROG	NOx	CO	SO2	Fugitive PM10	Exhaust PM10	PM10 Total	Fugitive PM2.5	Exhaust PM2.5	PM2.5 Total	Bio- CO2	NBio- CO2	Total CO2	CH4	N2O	CO2e	
tons/yr																	
MT/yr																	
Architectural Coating	0.0000					0.0000	0.0000		0.0000	0.0000	0.0000	0.0000	0.0000	0.0000	0.0000	0.0000	0.0000
Consumer Products	0.0000					0.0000	0.0000		0.0000	0.0000	0.0000	0.0000	0.0000	0.0000	0.0000	0.0000	0.0000
Landscaping	0.0000	0.0000	1.0000e-005	0.0000		0.0000	0.0000		0.0000	0.0000	0.0000	2.0000e-005	2.0000e-005	0.0000	0.0000	0.0000	2.0000e-005
Total	0.0000	0.0000	1.0000e-005	0.0000		0.0000	0.0000		0.0000	0.0000	0.0000	2.0000e-005	2.0000e-005	0.0000	0.0000	0.0000	2.0000e-005

BCTD DB-130 - San Francisco County, Annual

6.2 Area by SubCategory

Mitigated

SubCategory	tons/yr										MT/yr					
	ROG	NOx	CO	SO2	Fugitive PM10	Exhaust PM10	PM10 Total	Fugitive PM2.5	Exhaust PM2.5	PM2.5 Total	Bio- CO2	NBio- CO2	Total CO2	CH4	N2O	CO2e
Architectural Coating	0.0000					0.0000	0.0000	0.0000	0.0000	0.0000	0.0000	0.0000	0.0000	0.0000	0.0000	0.0000
Consumer Products	0.0000					0.0000	0.0000	0.0000	0.0000	0.0000	0.0000	0.0000	0.0000	0.0000	0.0000	0.0000
Landscaping	0.0000	0.0000	1.0000e-005	0.0000		0.0000	0.0000	0.0000	0.0000	0.0000	0.0000	2.0000e-005	2.0000e-005	0.0000	0.0000	2.0000e-005
Total	0.0000	0.0000	1.0000e-005	0.0000		0.0000	0.0000	0.0000	0.0000	0.0000	0.0000	2.0000e-005	2.0000e-005	0.0000	0.0000	2.0000e-005

7.0 Water Detail

7.1 Mitigation Measures Water

BCTD DB-130 - San Francisco County, Annual

	Total CO2	CH4	N2O	CO2e
Category	MT/yr			
Mitigated	0.0000	0.0000	0.0000	0.0000
Unmitigated	0.0000	0.0000	0.0000	0.0000

7.2 Water by Land Use

Unmitigated

	Indoor/Outdoor Use	Total CO2	CH4	N2O	CO2e
Land Use	Mgal	MT/yr			
User Defined Industrial	0 / 0	0.0000	0.0000	0.0000	0.0000
Total		0.0000	0.0000	0.0000	0.0000

BCTD DB-130 - San Francisco County, Annual

7.2 Water by Land Use

Mitigated

Land Use	Indoor/Outdoor Use	Total CO2	CH4	N2O	CO2e
	Mgal	MT/yr			
User Defined Industrial	0 / 0	0.0000	0.0000	0.0000	0.0000
Total		0.0000	0.0000	0.0000	0.0000

8.0 Waste Detail

8.1 Mitigation Measures Waste

Category/Year

Category/Year	Total CO2	CH4	N2O	CO2e
	MT/yr			
Mitigated	0.0000	0.0000	0.0000	0.0000
Unmitigated	0.0000	0.0000	0.0000	0.0000

BCTD DB-130 - San Francisco County, Annual

8.2 Waste by Land Use

Unmitigated

Land Use	Waste Disposed tons	MT/yr			
		Total CO2	CH4	N2O	CO2e
User Defined Industrial	0	0.0000	0.0000	0.0000	0.0000
Total		0.0000	0.0000	0.0000	0.0000

Mitigated

Land Use	Waste Disposed tons	MT/yr			
		Total CO2	CH4	N2O	CO2e
User Defined Industrial	0	0.0000	0.0000	0.0000	0.0000
Total		0.0000	0.0000	0.0000	0.0000

9.0 Operational Offroad

Equipment Type	Number	Hours/Day	Days/Year	Horse Power	Load Factor	Fuel Type
----------------	--------	-----------	-----------	-------------	-------------	-----------

BCTD DB-130 - San Francisco County, Annual

10.0 Stationary Equipment

Fire Pumps and Emergency Generators

Equipment Type	Number	Hours/Day	Hours/Year	Horse Power	Load Factor	Fuel Type

Boilers

Equipment Type	Number	Heat Input/Day	Heat Input/Year	Boiler Rating	Fuel Type

User Defined Equipment

Equipment Type	Number

11.0 Vegetation

DB-128R2 CalEEMod Runs

BCTD DB-128R2 - San Francisco County, Annual

BCTD DB-128R2
San Francisco County, Annual

1.0 Project Characteristics

1.1 Land Usage

Land Uses	Size	Metric	Lot Acreage	Floor Surface Area	Population
User Defined Industrial	1.00	User Defined Unit	2.50	0.00	0

1.2 Other Project Characteristics

Urbanization	Urban	Wind Speed (m/s)	4.6	Precipitation Freq (Days)	64
Climate Zone	5			Operational Year	2020

Utility Company Pacific Gas & Electric Company

CO2 Intensity (lb/MW/hr)	641.35	CH4 Intensity (lb/MW/hr)	0.029	N2O Intensity (lb/MW/hr)	0.006
---------------------------------	--------	---------------------------------	-------	---------------------------------	-------

1.3 User Entered Comments & Non-Default Data

Project Characteristics -

Land Use - Project acreage based on trenching limits from Construction Length and Phasing Map, assuming 15 ft width.

Construction Phase - Project specific construction schedule.

Off-road Equipment - Project specific equipment. Off highway truck to account for asphalt truck. Other construction equipment to account for jackhammer.

Grading - Based on material excavation (expanded): 9,711 CY; material backfill: 7,355 CY.

Trips and VMT - Based on 15 workers per day, 4 concrete daily truck trips (modeled as vendor trips), and total haul trips based on 16 CY capacity dump truck. Default miles.

Construction Off-road Equipment Mitigation - Watering twice per day in accordance with BAAQMD BMPs. Tier 2 engines, B20 Fuel. Generator assumed to be electrical.

BCTD DB-128R2 - San Francisco County, Annual

Table Name	Column Name	Default Value	New Value
tblConstEquipMitigation	FuelType	Diesel	Bio-diesel
tblConstEquipMitigation	FuelType	Diesel	Bio-diesel
tblConstEquipMitigation	FuelType	Diesel	Electrical
tblConstEquipMitigation	FuelType	Diesel	Bio-diesel
tblConstEquipMitigation	FuelType	Diesel	Bio-diesel
tblConstEquipMitigation	FuelType	Diesel	Bio-diesel
tblConstEquipMitigation	FuelType	Diesel	Bio-diesel
tblConstEquipMitigation	NumberOfEquipmentMitigated	0.00	1.00
tblConstEquipMitigation	NumberOfEquipmentMitigated	0.00	1.00
tblConstEquipMitigation	NumberOfEquipmentMitigated	0.00	1.00
tblConstEquipMitigation	NumberOfEquipmentMitigated	0.00	1.00
tblConstEquipMitigation	NumberOfEquipmentMitigated	0.00	2.00
tblConstEquipMitigation	NumberOfEquipmentMitigated	0.00	1.00
tblConstEquipMitigation	NumberOfEquipmentMitigated	0.00	1.00
tblConstEquipMitigation	Tier	No Change	Tier 2
tblConstEquipMitigation	Tier	No Change	Tier 2
tblConstEquipMitigation	Tier	No Change	Tier 2
tblConstEquipMitigation	Tier	No Change	Tier 2
tblConstEquipMitigation	Tier	No Change	Tier 2
tblConstEquipMitigation	Tier	No Change	Tier 2
tblConstructionPhase	NumDays	6.00	218.00
tblConstructionPhase	PhaseEndDate	4/10/2019	12/31/2019
tblConstructionPhase	PhaseStartDate	4/3/2019	3/1/2019
tblGrading	MaterialExported	0.00	9,711.00
tblGrading	MaterialImported	0.00	7,355.00

BCTD DB-128R2 - San Francisco County, Annual

tblLandUse	LotAcreage	0.00	2.50
tblOffRoadEquipment	LoadFactor	0.38	0.38
tblOffRoadEquipment	LoadFactor	0.42	0.42
tblOffRoadEquipment	LoadFactor	0.37	0.37
tblOffRoadEquipment	LoadFactor	0.38	0.38
tblOffRoadEquipment	LoadFactor	0.38	0.38
tblOffRoadEquipment	OffRoadEquipmentType		Excavators
tblOffRoadEquipment	OffRoadEquipmentType		Other Construction Equipment
tblOffRoadEquipment	OffRoadEquipmentType		Concrete/Industrial Saws
tblOffRoadEquipment	OffRoadEquipmentType		Generator Sets
tblOffRoadEquipment	OffRoadEquipmentType		Skid Steer Loaders
tblOffRoadEquipment	OffRoadEquipmentType		Off-Highway Trucks
tblOffRoadEquipment	OffRoadEquipmentType		Rollers
tblOffRoadEquipment	OffRoadEquipmentUnitAmount	1.00	0.00
tblOffRoadEquipment	OffRoadEquipmentUnitAmount	2.00	0.00
tblOffRoadEquipment	OffRoadEquipmentUnitAmount	1.00	0.00
tblOffRoadEquipment	UsageHours	8.00	0.00
tblOffRoadEquipment	UsageHours	7.00	0.00
tblOffRoadEquipment	UsageHours	8.00	0.00
tblTripsAndVMT	VendorTripNumber	0.00	8.00
tblTripsAndVMT	WorkerTripNumber	20.00	30.00

2.0 Emissions Summary

BCTD DB-128R2 - San Francisco County, Annual

2.1 Overall Construction
Unmitigated Construction

Year	tons/yr													MT/yr			
	ROG	NOx	CO	SO2	Fugitive PM10	Exhaust PM10	PM10 Total	Fugitive PM2.5	Exhaust PM2.5	PM2.5 Total	Bio- CO2	NBio- CO2	Total CO2	CH4	N2O	CO2e	
2019	0.3763	3.9939	3.0834	6.6900e-003	0.0520	0.1805	0.2324	0.0138	0.1701	0.1839	0.0000	612.7234	612.7234	0.1383	0.0000	616.1815	
Maximum	0.3763	3.9939	3.0834	6.6900e-003	0.0520	0.1805	0.2324	0.0138	0.1701	0.1839	0.0000	612.7234	612.7234	0.1383	0.0000	616.1815	

Mitigated Construction

Year	tons/yr													MT/yr			
	ROG	NOx	CO	SO2	Fugitive PM10	Exhaust PM10	PM10 Total	Fugitive PM2.5	Exhaust PM2.5	PM2.5 Total	Bio- CO2	NBio- CO2	Total CO2	CH4	N2O	CO2e	
2019	0.1504	4.3846	2.9136	6.6900e-003	0.0506	0.1083	0.1589	0.0136	0.1082	0.1218	80.9195	470.1958	551.1153	0.1344	0.0000	554.4759	
Maximum	0.1504	4.3846	2.9136	6.6900e-003	0.0506	0.1083	0.1589	0.0136	0.1082	0.1218	80.9195	470.1958	551.1153	0.1344	0.0000	554.4759	

Percent Reduction	ROG	NOx	CO	SO2	Fugitive PM10	Exhaust PM10	PM10 Total	Fugitive PM2.5	Exhaust PM2.5	PM2.5 Total	Bio- CO2	NBio- CO2	Total CO2	CH4	N2O	CO2e
	60.03	-9.78	5.51	0.00	2.68	40.00	31.65	1.52	36.40	33.78	0.00	23.26	10.05	2.82	0.00	10.01

BCTD DB-128R2 - San Francisco County, Annual

Quarter	Start Date	End Date	Maximum Unmitigated ROG + NOX (tons/quarter)	Maximum Mitigated ROG + NOX (tons/quarter)
1	3-1-2019	5-31-2019	1.3151	1.3648
2	6-1-2019	8-31-2019	1.3134	1.3630
3	9-1-2019	9-30-2019	0.4283	0.4445
		Highest	1.3151	1.3648

**2.2 Overall Operational
Unmitigated Operational**

Category	tons/yr											MT/yr				
	ROG	NOx	CO	SO2	Fugitive PM10	Exhaust PM10	PM10 Total	Fugitive PM2.5	Exhaust PM2.5	PM2.5 Total	Bio- CO2	NBio- CO2	Total CO2	CH4	N2O	CO2e
Area	0.0000	0.0000	1.0000e-005	0.0000	0.0000	0.0000	0.0000	0.0000	0.0000	0.0000	0.0000	2.0000e-005	2.0000e-005	0.0000	0.0000	2.0000e-005
Energy	0.0000	0.0000	0.0000	0.0000	0.0000	0.0000	0.0000	0.0000	0.0000	0.0000	0.0000	0.0000	0.0000	0.0000	0.0000	0.0000
Mobile	0.0000	0.0000	0.0000	0.0000	0.0000	0.0000	0.0000	0.0000	0.0000	0.0000	0.0000	0.0000	0.0000	0.0000	0.0000	0.0000
Waste																
Water																
Total	0.0000	0.0000	1.0000e-005	0.0000	0.0000	0.0000	0.0000	0.0000	0.0000	0.0000	0.0000	2.0000e-005	2.0000e-005	0.0000	0.0000	2.0000e-005

BCTD DB-128R2 - San Francisco County, Annual

2.2 Overall Operational

Mitigated Operational

Category	tons/yr											MT/yr					
	ROG	NOx	CO	SO2	Fugitive PM10	Exhaust PM10	PM10 Total	Fugitive PM2.5	Exhaust PM2.5	PM2.5 Total	Bio- CO2	NBio- CO2	Total CO2	CH4	N2O	CO2e	
Area	0.0000	0.0000	1.0000e-005	0.0000	0.0000	0.0000	0.0000	0.0000	0.0000	0.0000	0.0000	2.0000e-005	2.0000e-005	0.0000	0.0000	0.0000	2.0000e-005
Energy	0.0000	0.0000	0.0000	0.0000	0.0000	0.0000	0.0000	0.0000	0.0000	0.0000	0.0000	0.0000	0.0000	0.0000	0.0000	0.0000	0.0000
Mobile	0.0000	0.0000	0.0000	0.0000	0.0000	0.0000	0.0000	0.0000	0.0000	0.0000	0.0000	0.0000	0.0000	0.0000	0.0000	0.0000	0.0000
Waste	0.0000	0.0000	0.0000	0.0000	0.0000	0.0000	0.0000	0.0000	0.0000	0.0000	0.0000	0.0000	0.0000	0.0000	0.0000	0.0000	0.0000
Water	0.0000	0.0000	0.0000	0.0000	0.0000	0.0000	0.0000	0.0000	0.0000	0.0000	0.0000	0.0000	0.0000	0.0000	0.0000	0.0000	0.0000
Total	0.0000	0.0000	1.0000e-005	0.0000	0.0000	0.0000	0.0000	0.0000	0.0000	0.0000	0.0000	2.0000e-005	2.0000e-005	0.0000	0.0000	0.0000	2.0000e-005

Percent Reduction	tons/yr											MT/yr				
	ROG	NOx	CO	SO2	Fugitive PM10	Exhaust PM10	PM10 Total	Fugitive PM2.5	Exhaust PM2.5	PM2.5 Total	Bio- CO2	NBio- CO2	Total CO2	CH4	N2O	CO2e
0.00	0.00	0.00	0.00	0.00	0.00	0.00	0.00	0.00	0.00	0.00	0.00	0.00	0.00	0.00	0.00	0.00

3.0 Construction Detail

Construction Phase

Phase Number	Phase Name	Phase Type	Start Date	End Date	Num Days Week	Num Days	Phase Description
1	Trenching	Grading	3/1/2019	12/31/2019	5	218	

Acres of Grading (Site Preparation Phase): 0

BCTD DB-128R2 - San Francisco County, Annual

Acres of Grading (Grading Phase): 0

Acres of Paving: 0

Residential Indoor: 0; Residential Outdoor: 0; Non-Residential Indoor: 0; Non-Residential Outdoor: 0; Striped Parking Area: 0 (Architectural Coating – sqft)

OffRoad Equipment

Phase Name	Offroad Equipment Type	Amount	Usage Hours	Horse Power	Load Factor
Trenching	Excavators	1	8.00	158	0.38
Trenching	Other Construction Equipment	2	8.00	172	0.42
Trenching	Concrete/Industrial Saws	1	8.00	81	0.73
Trenching	Generator Sets	1	8.00	84	0.74
Trenching	Skid Steer Loaders	1	8.00	65	0.37
Trenching	Off-Highway Trucks	1	8.00	402	0.38
Trenching	Rollers	1	8.00	80	0.38
Trenching	Rubber Tired Dozers	0	0.00	247	0.40
Trenching	Tractors/Loaders/Backhoes	0	0.00	97	0.37
Trenching	Graders	0	0.00	187	0.41

Trips and VMT

Phase Name	Offroad Equipment Count	Worker Trip Number	Vendor Trip Number	Hauling Trip Number	Worker Trip Length	Vendor Trip Length	Hauling Trip Length	Worker Vehicle Class	Vendor Vehicle Class	Hauling Vehicle Class
Trenching	8	30.00	8.00	2,133.00	10.80	7.30	20.00	LD_Mix	HDT_Mix	HHDT

3.1 Mitigation Measures Construction

- Use Alternative Fuel for Construction Equipment
- Use Cleaner Engines for Construction Equipment
- Water Exposed Area

BCTD DB-128R2 - San Francisco County, Annual

3.2 Trenching - 2019

Unmitigated Construction On-Site

Category	ROG	NOx	CO	SO2	Fugitive PM10	Exhaust PM10	PM10 Total	Fugitive PM2.5	Exhaust PM2.5	PM2.5 Total	Bio- CO2	NBio- CO2	Total CO2	CH4	N2O	CO2e
	tons/yr															
	MT/yr															
Fugitive Dust	0.3518	3.4656	2.8553	5.2500e-003	2.5200e-003	0.0000	2.5200e-003	3.8000e-004	0.0000	3.8000e-004	0.0000	0.0000	0.0000	0.0000	0.0000	0.0000
Off-Road	0.3518	3.4656	2.8553	5.2500e-003	0.1780	0.1780	0.1780	0.1678	0.1678	0.1678	0.0000	466.2056	466.2056	0.1175	0.0000	469.1430
Total	0.3518	3.4656	2.8553	5.2500e-003	2.5200e-003	0.1780	0.1806	3.8000e-004	0.1678	0.1681	0.0000	466.2056	466.2056	0.1175	0.0000	469.1430

Unmitigated Construction Off-Site

Category	ROG	NOx	CO	SO2	Fugitive PM10	Exhaust PM10	PM10 Total	Fugitive PM2.5	Exhaust PM2.5	PM2.5 Total	Bio- CO2	NBio- CO2	Total CO2	CH4	N2O	CO2e
	tons/yr															
	MT/yr															
Hauling	9.7600e-003	0.4020	0.1122	9.2000e-004	0.0179	1.5200e-003	0.0194	4.9100e-003	1.4600e-003	6.3700e-003	0.0000	96.7670	96.7670	0.0169	0.0000	97.1904
Vendor	3.9400e-003	0.1190	0.0353	2.4000e-004	5.7000e-003	7.4000e-004	6.4400e-003	1.6500e-003	7.0000e-004	2.3500e-003	0.0000	24.3798	24.3798	3.2900e-003	0.0000	24.4620
Worker	0.0107	7.4100e-003	0.0806	2.8000e-004	0.0258	2.0000e-004	0.0260	6.8700e-003	1.8000e-004	7.0600e-003	0.0000	25.3710	25.3710	6.0000e-004	0.0000	25.3861
Total	0.0244	0.5283	0.2281	1.4400e-003	0.0494	2.4600e-003	0.0519	0.0134	2.3400e-003	0.0158	0.0000	146.5179	146.5179	0.0208	0.0000	147.0386

BCTD DB-128R2 - San Francisco County, Annual

3.2 Trenching - 2019

Mitigated Construction On-Site

Category	tons/yr											MT/yr				
	ROG	NOx	CO	SO2	Fugitive PM10	Exhaust PM10	PM10 Total	Fugitive PM2.5	Exhaust PM2.5	PM2.5 Total	Bio- CO2	NBio- CO2	Total CO2	CH4	N2O	CO2e
Fugitive Dust					1.1300e-003	0.0000	1.1300e-003	1.7000e-004	0.0000	1.7000e-004	0.0000	0.0000	0.0000	0.0000	0.0000	0.0000
Off-Road	0.1260	3.8562	2.6855	5.2500e-003	1.1300e-003	0.1058	0.1058	0.1058	0.1058	0.1058	80.9195	323.6780	404.5975	0.1136	0.0000	407.4373
Total	0.1260	3.8562	2.6855	5.2500e-003	1.1300e-003	0.1058	0.1070	1.7000e-004	0.1058	0.1060	80.9195	323.6780	404.5975	0.1136	0.0000	407.4373

Mitigated Construction Off-Site

Category	tons/yr											MT/yr				
	ROG	NOx	CO	SO2	Fugitive PM10	Exhaust PM10	PM10 Total	Fugitive PM2.5	Exhaust PM2.5	PM2.5 Total	Bio- CO2	NBio- CO2	Total CO2	CH4	N2O	CO2e
Hauling	9.7600e-003	0.4020	0.1122	9.2000e-004	0.0179	1.5200e-003	0.0194	4.9100e-003	1.4600e-003	6.3700e-003	0.0000	96.7670	96.7670	0.0169	0.0000	97.1904
Vendor	3.9400e-003	0.1190	0.0353	2.4000e-004	5.7000e-003	7.4000e-004	6.4400e-003	1.6500e-003	7.0000e-004	2.3500e-003	0.0000	24.3798	24.3798	3.2900e-003	0.0000	24.4620
Worker	0.0107	7.4100e-003	0.0806	2.8000e-004	0.0258	2.0000e-004	0.0260	6.8700e-003	1.8000e-004	7.0600e-003	0.0000	25.3710	25.3710	6.0000e-004	0.0000	25.3861
Total	0.0244	0.5283	0.2281	1.4400e-003	0.0494	2.4600e-003	0.0519	0.0134	2.3400e-003	0.0158	0.0000	146.5179	146.5179	0.0208	0.0000	147.0386

4.0 Operational Detail - Mobile

BCTD DB-128R2 - San Francisco County, Annual

4.1 Mitigation Measures Mobile

Category	tons/yr										MT/yr					
	ROG	NOx	CO	SO2	Fugitive PM10	Exhaust PM10	PM10 Total	Fugitive PM2.5	Exhaust PM2.5	PM2.5 Total	Bio- CO2	NBio- CO2	Total CO2	CH4	N2O	CO2e
Mitigated	0.0000	0.0000	0.0000	0.0000	0.0000	0.0000	0.0000	0.0000	0.0000	0.0000	0.0000	0.0000	0.0000	0.0000	0.0000	0.0000
Unmitigated	0.0000	0.0000	0.0000	0.0000	0.0000	0.0000	0.0000	0.0000	0.0000	0.0000	0.0000	0.0000	0.0000	0.0000	0.0000	0.0000

4.2 Trip Summary Information

Land Use	Average Daily Trip Rate			Unmitigated Annual VMT	Mitigated Annual VMT
	Weekday	Saturday	Sunday		
User Defined Industrial	0.00	0.00	0.00		
Total	0.00	0.00	0.00		

4.3 Trip Type Information

Land Use	Miles				Trip %				Trip Purpose %			
	H-W or C-W	H-O or C-NW	H-S or C-C	H-O or C-NW	H-W or C-W	H-S or C-C	H-O or C-NW	H-O or C-NW	Primary	Diverted	Pass-by	
User Defined Industrial	9.50	7.30	7.30	7.30	0.00	0.00	0.00	0.00	0	0	0	

4.4 Fleet Mix

Land Use	LDA	LDT1	LDT2	MDV	LHD1	LHD2	MHD	HHD	OBUS	UBUS	MCY	SBUS	MH
User Defined Industrial	0.607015	0.041018	0.191033	0.097570	0.015386	0.004865	0.027149	0.008727	0.004280	0.004624	0.006947	0.000926	0.000460

5.3 Energy by Land Use - Electricity

Unmitigated

Land Use	Electricity Use	Total CO2	CH4	N2O	CO2e
	kWh/yr	MT/yr			
User Defined Industrial	0	0.0000	0.0000	0.0000	0.0000
Total		0.0000	0.0000	0.0000	0.0000

Mitigated

Land Use	Electricity Use	Total CO2	CH4	N2O	CO2e
	kWh/yr	MT/yr			
User Defined Industrial	0	0.0000	0.0000	0.0000	0.0000
Total		0.0000	0.0000	0.0000	0.0000

6.0 Area Detail

6.1 Mitigation Measures Area

BCTD DB-128R2 - San Francisco County, Annual

Category	ROG	NOx	CO	SO2	Fugitive PM10	Exhaust PM10	PM10 Total	Fugitive PM2.5	Exhaust PM2.5	PM2.5 Total	Bio- CO2	NBio- CO2	Total CO2	CH4	N2O	CO2e	
tons/yr																	
MT/yr																	
Mitigated	0.0000	0.0000	1.0000e-005	0.0000	0.0000	0.0000	0.0000	0.0000	0.0000	0.0000	0.0000	2.0000e-005	2.0000e-005	0.0000	0.0000	0.0000	2.0000e-005
Unmitigated	0.0000	0.0000	1.0000e-005	0.0000	0.0000	0.0000	0.0000	0.0000	0.0000	0.0000	0.0000	2.0000e-005	2.0000e-005	0.0000	0.0000	0.0000	2.0000e-005

6.2 Area by SubCategory

Unmitigated

SubCategory	ROG	NOx	CO	SO2	Fugitive PM10	Exhaust PM10	PM10 Total	Fugitive PM2.5	Exhaust PM2.5	PM2.5 Total	Bio- CO2	NBio- CO2	Total CO2	CH4	N2O	CO2e	
tons/yr																	
MT/yr																	
Architectural Coating	0.0000					0.0000	0.0000		0.0000	0.0000	0.0000	0.0000	0.0000	0.0000	0.0000	0.0000	0.0000
Consumer Products	0.0000					0.0000	0.0000		0.0000	0.0000	0.0000	0.0000	0.0000	0.0000	0.0000	0.0000	0.0000
Landscaping	0.0000	0.0000	1.0000e-005	0.0000		0.0000	0.0000		0.0000	0.0000	0.0000	2.0000e-005	2.0000e-005	0.0000	0.0000	0.0000	2.0000e-005
Total	0.0000	0.0000	1.0000e-005	0.0000		0.0000	0.0000		0.0000	0.0000	0.0000	2.0000e-005	2.0000e-005	0.0000	0.0000	0.0000	2.0000e-005

BCTD DB-128R2 - San Francisco County, Annual

6.2 Area by SubCategory

Mitigated

SubCategory	tons/yr										MT/yr						
	ROG	NOx	CO	SO2	Fugitive PM10	Exhaust PM10	PM10 Total	Fugitive PM2.5	Exhaust PM2.5	PM2.5 Total	Bio- CO2	NBio- CO2	Total CO2	CH4	N2O	CO2e	
Architectural Coating	0.0000					0.0000	0.0000	0.0000	0.0000	0.0000	0.0000	0.0000	0.0000	0.0000	0.0000	0.0000	0.0000
Consumer Products	0.0000					0.0000	0.0000	0.0000	0.0000	0.0000	0.0000	0.0000	0.0000	0.0000	0.0000	0.0000	0.0000
Landscaping	0.0000	0.0000	1.0000e-005	0.0000		0.0000	0.0000	0.0000	0.0000	0.0000	0.0000	2.0000e-005	2.0000e-005	0.0000	0.0000	0.0000	2.0000e-005
Total	0.0000	0.0000	1.0000e-005	0.0000		0.0000	0.0000	0.0000	0.0000	0.0000	0.0000	2.0000e-005	2.0000e-005	0.0000	0.0000	0.0000	2.0000e-005

7.0 Water Detail

7.1 Mitigation Measures Water

BCTD DB-128R2 - San Francisco County, Annual

	Total CO2	CH4	N2O	CO2e
Category	MT/yr			
Mitigated	0.0000	0.0000	0.0000	0.0000
Unmitigated	0.0000	0.0000	0.0000	0.0000

7.2 Water by Land Use

Unmitigated

	Indoor/Outdoor Use	Total CO2	CH4	N2O	CO2e
Land Use	Mgal	MT/yr			
User Defined Industrial	0 / 0	0.0000	0.0000	0.0000	0.0000
Total		0.0000	0.0000	0.0000	0.0000

7.2 Water by Land Use

Mitigated

Land Use	Indoor/Outdoor Use	Total CO2	CH4	N2O	CO2e
	Mgal	MT/yr			
User Defined Industrial	0 / 0	0.0000	0.0000	0.0000	0.0000
Total		0.0000	0.0000	0.0000	0.0000

8.0 Waste Detail

8.1 Mitigation Measures Waste

Category/Year

Category/Year	Total CO2	CH4	N2O	CO2e
	MT/yr			
Mitigated	0.0000	0.0000	0.0000	0.0000
Unmitigated	0.0000	0.0000	0.0000	0.0000

BCTD DB-128R2 - San Francisco County, Annual

8.2 Waste by Land Use

Unmitigated

Land Use	Waste Disposed tons	Total CO2				CO2e
		CH4	N2O	MT/yr		
User Defined Industrial	0	0.0000	0.0000	0.0000	0.0000	0.0000
Total		0.0000	0.0000	0.0000	0.0000	0.0000

Mitigated

Land Use	Waste Disposed tons	Total CO2				CO2e
		CH4	N2O	MT/yr		
User Defined Industrial	0	0.0000	0.0000	0.0000	0.0000	0.0000
Total		0.0000	0.0000	0.0000	0.0000	0.0000

9.0 Operational Offroad

Equipment Type	Number	Hours/Day	Days/Year	Horse Power	Load Factor	Fuel Type
----------------	--------	-----------	-----------	-------------	-------------	-----------

10.0 Stationary Equipment

Fire Pumps and Emergency Generators

Equipment Type	Number	Hours/Day	Hours/Year	Horse Power	Load Factor	Fuel Type
----------------	--------	-----------	------------	-------------	-------------	-----------

Boilers

Equipment Type	Number	Heat Input/Day	Heat Input/Year	Boiler Rating	Fuel Type
----------------	--------	----------------	-----------------	---------------	-----------

User Defined Equipment

Equipment Type	Number
----------------	--------

11.0 Vegetation

BCTD DB-128R2 - San Francisco County, Annual

BCTD DB-128R2
San Francisco County, Annual

1.0 Project Characteristics

1.1 Land Usage

Land Uses	Size	Metric	Lot Acreage	Floor Surface Area	Population
User Defined Industrial	1.00	User Defined Unit	2.50	0.00	0

1.2 Other Project Characteristics

Urbanization	Urban	Wind Speed (m/s)	4.6	Precipitation Freq (Days)	64
Climate Zone	5			Operational Year	2020

Utility Company Pacific Gas & Electric Company

CO2 Intensity (lb/MW/hr)	641.35	CH4 Intensity (lb/MW/hr)	0.029	N2O Intensity (lb/MW/hr)	0.006
---------------------------------	--------	---------------------------------	-------	---------------------------------	-------

1.3 User Entered Comments & Non-Default Data

Project Characteristics -

Land Use - Project acreage based on trenching limits from Construction Length and Phasing Map, assuming 15 ft width.

Construction Phase - Project specific construction schedule.

Off-road Equipment - Project specific equipment. Off highway truck to account for asphalt truck. Other construction equipment to account for jackhammer.

Grading - Based on material excavation (expanded): 9,711 CY; material backfill: 7,355 CY.

Trips and VMT - Based on 15 workers per day, 4 concrete daily truck trips (modeled as vendor trips), and total haul trips based on 16 CY capacity dump truck. Default miles.

Construction Off-road Equipment Mitigation - Watering twice per day in accordance with BAAQMD BMPs. Diesel Tier 2 engines, Level 3 VDECS. Generator assumed to be electrical.

BCTD DB-128R2 - San Francisco County, Annual

Table Name	Column Name	Default Value	New Value
tblConstEquipMitigation	DPF	No Change	Level 3
tblConstEquipMitigation	DPF	No Change	Level 3
tblConstEquipMitigation	DPF	No Change	Level 3
tblConstEquipMitigation	DPF	No Change	Level 3
tblConstEquipMitigation	DPF	No Change	Level 3
tblConstEquipMitigation	DPF	No Change	Level 3
tblConstEquipMitigation	FuelType	Diesel	Electrical
tblConstEquipMitigation	NumberOfEquipmentMitigated	0.00	1.00
tblConstEquipMitigation	NumberOfEquipmentMitigated	0.00	1.00
tblConstEquipMitigation	NumberOfEquipmentMitigated	0.00	1.00
tblConstEquipMitigation	NumberOfEquipmentMitigated	0.00	1.00
tblConstEquipMitigation	NumberOfEquipmentMitigated	0.00	2.00
tblConstEquipMitigation	NumberOfEquipmentMitigated	0.00	1.00
tblConstEquipMitigation	NumberOfEquipmentMitigated	0.00	1.00
tblConstEquipMitigation	Tier	No Change	Tier 2
tblConstEquipMitigation	Tier	No Change	Tier 2
tblConstEquipMitigation	Tier	No Change	Tier 2
tblConstEquipMitigation	Tier	No Change	Tier 2
tblConstEquipMitigation	Tier	No Change	Tier 2
tblConstEquipMitigation	Tier	No Change	Tier 2
tblConstructionPhase	NumDays	6.00	218.00
tblConstructionPhase	PhaseEndDate	4/10/2019	12/31/2019
tblConstructionPhase	PhaseStartDate	4/3/2019	3/1/2019
tblGrading	MaterialExported	0.00	9,711.00
tblGrading	MaterialImported	0.00	7,355.00

BCTD DB-128R2 - San Francisco County, Annual

tblLandUse	LotAcreage	0.00	2.50
tblOffRoadEquipment	LoadFactor	0.38	0.38
tblOffRoadEquipment	LoadFactor	0.42	0.42
tblOffRoadEquipment	LoadFactor	0.37	0.37
tblOffRoadEquipment	LoadFactor	0.38	0.38
tblOffRoadEquipment	LoadFactor	0.38	0.38
tblOffRoadEquipment	OffRoadEquipmentType		Excavators
tblOffRoadEquipment	OffRoadEquipmentType		Other Construction Equipment
tblOffRoadEquipment	OffRoadEquipmentType		Concrete/Industrial Saws
tblOffRoadEquipment	OffRoadEquipmentType		Generator Sets
tblOffRoadEquipment	OffRoadEquipmentType		Skid Steer Loaders
tblOffRoadEquipment	OffRoadEquipmentType		Off-Highway Trucks
tblOffRoadEquipment	OffRoadEquipmentType		Rollers
tblOffRoadEquipment	OffRoadEquipmentUnitAmount	1.00	0.00
tblOffRoadEquipment	OffRoadEquipmentUnitAmount	2.00	0.00
tblOffRoadEquipment	OffRoadEquipmentUnitAmount	1.00	0.00
tblOffRoadEquipment	UsageHours	8.00	0.00
tblOffRoadEquipment	UsageHours	7.00	0.00
tblOffRoadEquipment	UsageHours	8.00	0.00
tblTripsAndVMT	VendorTripNumber	0.00	8.00
tblTripsAndVMT	WorkerTripNumber	20.00	30.00

2.0 Emissions Summary

BCTD DB-128R2 - San Francisco County, Annual

2.1 Overall Construction
Unmitigated Construction

Year	tons/yr											MT/yr				
	ROG	NOx	CO	SO2	Fugitive PM10	Exhaust PM10	PM10 Total	Fugitive PM2.5	Exhaust PM2.5	PM2.5 Total	Bio- CO2	NBio- CO2	Total CO2	CH4	N2O	CO2e
2019	0.3763	3.9939	3.0834	6.6900e-003	0.0520	0.1805	0.2324	0.0138	0.1701	0.1839	0.0000	612.7234	612.7234	0.1383	0.0000	616.1815
Maximum	0.3763	3.9939	3.0834	6.6900e-003	0.0520	0.1805	0.2324	0.0138	0.1701	0.1839	0.0000	612.7234	612.7234	0.1383	0.0000	616.1815

Mitigated Construction

Year	tons/yr											MT/yr				
	ROG	NOx	CO	SO2	Fugitive PM10	Exhaust PM10	PM10 Total	Fugitive PM2.5	Exhaust PM2.5	PM2.5 Total	Bio- CO2	NBio- CO2	Total CO2	CH4	N2O	CO2e
2019	0.1841	4.3090	3.2455	6.6900e-003	0.0506	0.0201	0.0707	0.0136	0.0200	0.0336	0.0000	551.1153	551.1153	0.1344	0.0000	554.4759
Maximum	0.1841	4.3090	3.2455	6.6900e-003	0.0506	0.0201	0.0707	0.0136	0.0200	0.0336	0.0000	551.1153	551.1153	0.1344	0.0000	554.4759

Percent Reduction	ROG	NOx	CO	SO2	Fugitive PM10	Exhaust PM10	PM10 Total	Fugitive PM2.5	Exhaust PM2.5	PM2.5 Total	Bio- CO2	NBio- CO2	Total CO2	CH4	N2O	CO2e
	51.08	-7.89	-5.26	0.00	2.68	88.85	69.59	1.52	88.24	81.72	0.00	10.05	10.05	2.82	0.00	10.01

BCTD DB-128R2 - San Francisco County, Annual

Quarter	Start Date	End Date	Maximum Unmitigated ROG + NOX (tons/quarter)	Maximum Mitigated ROG + NOX (tons/quarter)
1	3-1-2019	5-31-2019	1.3151	1.3521
2	6-1-2019	8-31-2019	1.3134	1.3504
3	9-1-2019	9-30-2019	0.4283	0.4403
		Highest	1.3151	1.3521

**2.2 Overall Operational
Unmitigated Operational**

Category	tons/yr											MT/yr					
	ROG	NOx	CO	SO2	Fugitive PM10	Exhaust PM10	PM10 Total	Fugitive PM2.5	Exhaust PM2.5	PM2.5 Total	Bio- CO2	NBio- CO2	Total CO2	CH4	N2O	CO2e	
Area	0.0000	0.0000	1.0000e-005	0.0000	0.0000	0.0000	0.0000	0.0000	0.0000	0.0000	0.0000	2.0000e-005	2.0000e-005	0.0000	0.0000	0.0000	2.0000e-005
Energy	0.0000	0.0000	0.0000	0.0000	0.0000	0.0000	0.0000	0.0000	0.0000	0.0000	0.0000	0.0000	0.0000	0.0000	0.0000	0.0000	0.0000
Mobile	0.0000	0.0000	0.0000	0.0000	0.0000	0.0000	0.0000	0.0000	0.0000	0.0000	0.0000	0.0000	0.0000	0.0000	0.0000	0.0000	0.0000
Waste																	
Water																	
Total	0.0000	0.0000	1.0000e-005	0.0000	0.0000	0.0000	0.0000	0.0000	0.0000	0.0000	0.0000	2.0000e-005	2.0000e-005	0.0000	0.0000	0.0000	2.0000e-005

BCTD DB-128R2 - San Francisco County, Annual

2.2 Overall Operational

Mitigated Operational

Category	tons/yr											MT/yr					
	ROG	NOx	CO	SO2	Fugitive PM10	Exhaust PM10	PM10 Total	Fugitive PM2.5	Exhaust PM2.5	PM2.5 Total	Bio- CO2	NBio- CO2	Total CO2	CH4	N2O	CO2e	
Area	0.0000	0.0000	1.0000e-005	0.0000	0.0000	0.0000	0.0000	0.0000	0.0000	0.0000	0.0000	2.0000e-005	2.0000e-005	0.0000	0.0000	0.0000	2.0000e-005
Energy	0.0000	0.0000	0.0000	0.0000	0.0000	0.0000	0.0000	0.0000	0.0000	0.0000	0.0000	0.0000	0.0000	0.0000	0.0000	0.0000	0.0000
Mobile	0.0000	0.0000	0.0000	0.0000	0.0000	0.0000	0.0000	0.0000	0.0000	0.0000	0.0000	0.0000	0.0000	0.0000	0.0000	0.0000	0.0000
Waste	0.0000	0.0000	0.0000	0.0000	0.0000	0.0000	0.0000	0.0000	0.0000	0.0000	0.0000	0.0000	0.0000	0.0000	0.0000	0.0000	0.0000
Water	0.0000	0.0000	0.0000	0.0000	0.0000	0.0000	0.0000	0.0000	0.0000	0.0000	0.0000	0.0000	0.0000	0.0000	0.0000	0.0000	0.0000
Total	0.0000	0.0000	1.0000e-005	0.0000	0.0000	0.0000	0.0000	0.0000	0.0000	0.0000	0.0000	2.0000e-005	2.0000e-005	0.0000	0.0000	0.0000	2.0000e-005

Percent Reduction	tons/yr											MT/yr				
	ROG	NOx	CO	SO2	Fugitive PM10	Exhaust PM10	PM10 Total	Fugitive PM2.5	Exhaust PM2.5	PM2.5 Total	Bio- CO2	NBio- CO2	Total CO2	CH4	N2O	CO2e
0.00	0.00	0.00	0.00	0.00	0.00	0.00	0.00	0.00	0.00	0.00	0.00	0.00	0.00	0.00	0.00	0.00

3.0 Construction Detail

Construction Phase

Phase Number	Phase Name	Phase Type	Start Date	End Date	Num Days Week	Num Days	Phase Description
1	Trenching	Grading	3/1/2019	12/31/2019	5	218	

Acres of Grading (Site Preparation Phase): 0

BCTD DB-128R2 - San Francisco County, Annual

Acres of Grading (Grading Phase): 0

Acres of Paving: 0

Residential Indoor: 0; Residential Outdoor: 0; Non-Residential Indoor: 0; Non-Residential Outdoor: 0; Striped Parking Area: 0 (Architectural Coating – sqft)

OffRoad Equipment

Phase Name	Offroad Equipment Type	Amount	Usage Hours	Horse Power	Load Factor
Trenching	Excavators	1	8.00	158	0.38
Trenching	Other Construction Equipment	2	8.00	172	0.42
Trenching	Concrete/Industrial Saws	1	8.00	81	0.73
Trenching	Generator Sets	1	8.00	84	0.74
Trenching	Skid Steer Loaders	1	8.00	65	0.37
Trenching	Off-Highway Trucks	1	8.00	402	0.38
Trenching	Rollers	1	8.00	80	0.38
Trenching	Rubber Tired Dozers	0	0.00	247	0.40
Trenching	Tractors/Loaders/Backhoes	0	0.00	97	0.37
Trenching	Graders	0	0.00	187	0.41

Trips and VMT

Phase Name	Offroad Equipment Count	Worker Trip Number	Vendor Trip Number	Hauling Trip Number	Worker Trip Length	Vendor Trip Length	Hauling Trip Length	Worker Vehicle Class	Vendor Vehicle Class	Hauling Vehicle Class
Trenching	8	30.00	8.00	2,133.00	10.80	7.30	20.00	LD_Mix	HDT_Mix	HHDT

3.1 Mitigation Measures Construction

BCTD DB-128R2 - San Francisco County, Annual

- Use Alternative Fuel for Construction Equipment
- Use Cleaner Engines for Construction Equipment
- Use DPF for Construction Equipment
- Water Exposed Area

3.2 Trenching - 2019

Unmitigated Construction On-Site

Category	ROG	NOx	CO	SO2	Fugitive PM10	Exhaust PM10	PM10 Total	Fugitive PM2.5	Exhaust PM2.5	PM2.5 Total	Bio- CO2	NBio- CO2	Total CO2	CH4	N2O	CO2e	
	tons/yr																
	MT/yr																
Fugitive Dust					2.5200e-003	0.0000	2.5200e-003	3.8000e-004	0.0000	3.8000e-004	0.0000	0.0000	0.0000	0.0000	0.0000	0.0000	0.0000
Off-Road	0.3518	3.4656	2.8553	5.2500e-003	0.1780	0.1780	0.1780	0.1678	0.1678	0.1678	0.0000	466.2056	466.2056	0.1175	0.0000	469.1430	
Total	0.3518	3.4656	2.8553	5.2500e-003	2.5200e-003	0.1780	0.1806	3.8000e-004	0.1678	0.1681	0.0000	466.2056	466.2056	0.1175	0.0000	469.1430	

BCTD DB-128R2 - San Francisco County, Annual

3.2 Trenching - 2019
Unmitigated Construction Off-Site

Category	tons/yr										MT/yr					
	ROG	NOx	CO	SO2	Fugitive PM10	Exhaust PM10	PM10 Total	Fugitive PM2.5	Exhaust PM2.5	PM2.5 Total	Bio- CO2	NBio- CO2	Total CO2	CH4	N2O	CO2e
Hauling	9.7600e-003	0.4020	0.1122	9.2000e-004	0.0179	1.5200e-003	0.0194	4.9100e-003	1.4600e-003	6.3700e-003	0.0000	96.7670	96.7670	0.0169	0.0000	97.1904
Vendor	3.9400e-003	0.1190	0.0353	2.4000e-004	5.7000e-003	7.4000e-004	6.4400e-003	1.6500e-003	7.0000e-004	2.3500e-003	0.0000	24.3798	24.3798	3.2900e-003	0.0000	24.4620
Worker	0.0107	7.4100e-003	0.0806	2.8000e-004	0.0258	2.0000e-004	0.0260	6.8700e-003	1.8000e-004	7.0600e-003	0.0000	25.3710	25.3710	6.0000e-004	0.0000	25.3861
Total	0.0244	0.5283	0.2281	1.4400e-003	0.0494	2.4600e-003	0.0519	0.0134	2.3400e-003	0.0158	0.0000	146.5179	146.5179	0.0208	0.0000	147.0386

Mitigated Construction On-Site

Category	tons/yr										MT/yr					
	ROG	NOx	CO	SO2	Fugitive PM10	Exhaust PM10	PM10 Total	Fugitive PM2.5	Exhaust PM2.5	PM2.5 Total	Bio- CO2	NBio- CO2	Total CO2	CH4	N2O	CO2e
Fugitive Dust					1.1300e-003	0.0000	1.1300e-003	1.7000e-004	0.0000	1.7000e-004	0.0000	0.0000	0.0000	0.0000	0.0000	0.0000
Off-Road	0.1597	3.7806	3.0175	5.2500e-003	0.0177	0.0177	0.0177	0.0177	0.0177	0.0177	0.0000	404.5975	404.5975	0.1136	0.0000	407.4373
Total	0.1597	3.7806	3.0175	5.2500e-003	1.1300e-003	0.0177	0.0188	1.7000e-004	0.0177	0.0178	0.0000	404.5975	404.5975	0.1136	0.0000	407.4373

BCTD DB-128R2 - San Francisco County, Annual

3.2 Trenching - 2019

Mitigated Construction Off-Site

Category	tons/yr										MT/yr					
	ROG	NOx	CO	SO2	Fugitive PM10	Exhaust PM10	PM10 Total	Fugitive PM2.5	Exhaust PM2.5	PM2.5 Total	Bio- CO2	NBio- CO2	Total CO2	CH4	N2O	CO2e
Hauling	9.7600e-003	0.4020	0.1122	9.2000e-004	0.0179	1.5200e-003	0.0194	4.9100e-003	1.4600e-003	6.3700e-003	0.0000	96.7670	96.7670	0.0169	0.0000	97.1904
Vendor	3.9400e-003	0.1190	0.0353	2.4000e-004	5.7000e-003	7.4000e-004	6.4400e-003	1.6500e-003	7.0000e-004	2.3500e-003	0.0000	24.3798	24.3798	3.2900e-003	0.0000	24.4620
Worker	0.0107	7.4100e-003	0.0806	2.8000e-004	0.0258	2.0000e-004	0.0260	6.8700e-003	1.8000e-004	7.0600e-003	0.0000	25.3710	25.3710	6.0000e-004	0.0000	25.3861
Total	0.0244	0.5283	0.2281	1.4400e-003	0.0494	2.4600e-003	0.0519	0.0134	2.3400e-003	0.0158	0.0000	146.5179	146.5179	0.0208	0.0000	147.0386

4.0 Operational Detail - Mobile

4.1 Mitigation Measures Mobile

BCTD DB-128R2 - San Francisco County, Annual

Category	tons/yr											MT/yr				
	ROG	NOx	CO	SO2	Fugitive PM10	Exhaust PM10	PM10 Total	Fugitive PM2.5	Exhaust PM2.5	PM2.5 Total	Bio- CO2	NBio- CO2	Total CO2	CH4	N2O	CO2e
Mitigated	0.0000	0.0000	0.0000	0.0000	0.0000	0.0000	0.0000	0.0000	0.0000	0.0000	0.0000	0.0000	0.0000	0.0000	0.0000	0.0000
Unmitigated	0.0000	0.0000	0.0000	0.0000	0.0000	0.0000	0.0000	0.0000	0.0000	0.0000	0.0000	0.0000	0.0000	0.0000	0.0000	0.0000

4.2 Trip Summary Information

Land Use	Average Daily Trip Rate			Unmitigated Annual VMT	Mitigated Annual VMT
	Weekday	Saturday	Sunday		
User Defined Industrial	0.00	0.00	0.00		
Total	0.00	0.00	0.00		

4.3 Trip Type Information

Land Use	Miles						Trip %			Trip Purpose %		
	H-W or C-C	H-S or C-C	H-O or C-NW	H-W or C-W	H-S or C-C	H-O or C-NW	H-W or C-W	H-S or C-C	H-O or C-NW	Primary	Diverted	Pass-by
User Defined Industrial	9.50	7.30	7.30	0.00	0.00	0.00	0.00	0.00	0.00	0	0	0

4.4 Fleet Mix

Land Use	LDA	LDT1	LDT2	MDV	LHD1	LHD2	MHD	HHD	OBUS	UBUS	MCY	SBUS	MH
User Defined Industrial	0.607015	0.041018	0.191033	0.087570	0.015386	0.004865	0.027149	0.008727	0.004280	0.004624	0.006947	0.000926	0.000460

5.0 Energy Detail

Historical Energy Use: N

5.3 Energy by Land Use - Electricity

Mitigated

Land Use	Electricity Use kWh/yr	Total CO2	CH4	N2O	CO2e
User Defined Industrial	0	0.0000	0.0000	0.0000	0.0000
Total		0.0000	0.0000	0.0000	0.0000

6.0 Area Detail

6.1 Mitigation Measures Area

Category	tons/yr																
	ROG	NOx	CO	SO2	Fugitive PM10	Exhaust PM10	PM10 Total	Fugitive PM2.5	Exhaust PM2.5	PM2.5 Total	Bio- CO2	NBio- CO2	Total CO2	CH4	N2O	CO2e	
Mitigated	0.0000	0.0000	1.0000e-005	0.0000	0.0000	0.0000	0.0000	0.0000	0.0000	0.0000	0.0000	2.0000e-005	2.0000e-005	0.0000	0.0000	0.0000	2.0000e-005
Unmitigated	0.0000	0.0000	1.0000e-005	0.0000	0.0000	0.0000	0.0000	0.0000	0.0000	0.0000	0.0000	2.0000e-005	2.0000e-005	0.0000	0.0000	0.0000	2.0000e-005

BCTD DB-128R2 - San Francisco County, Annual

6.2 Area by SubCategory

Unmitigated

SubCategory	tons/yr										MT/yr					
	ROG	NOx	CO	SO2	Fugitive PM10	Exhaust PM10	PM10 Total	Fugitive PM2.5	Exhaust PM2.5	PM2.5 Total	Bio- CO2	NBio- CO2	Total CO2	CH4	N2O	CO2e
Architectural Coating	0.0000					0.0000	0.0000	0.0000	0.0000	0.0000	0.0000	0.0000	0.0000	0.0000	0.0000	0.0000
Consumer Products	0.0000					0.0000	0.0000	0.0000	0.0000	0.0000	0.0000	0.0000	0.0000	0.0000	0.0000	0.0000
Landscaping	0.0000	0.0000	1.0000e-005	0.0000		0.0000	0.0000	0.0000	0.0000	0.0000	0.0000	2.0000e-005	2.0000e-005	0.0000	0.0000	2.0000e-005
Total	0.0000	0.0000	1.0000e-005	0.0000		0.0000	0.0000	0.0000	0.0000	0.0000	0.0000	2.0000e-005	2.0000e-005	0.0000	0.0000	2.0000e-005

Mitigated

SubCategory	tons/yr										MT/yr					
	ROG	NOx	CO	SO2	Fugitive PM10	Exhaust PM10	PM10 Total	Fugitive PM2.5	Exhaust PM2.5	PM2.5 Total	Bio- CO2	NBio- CO2	Total CO2	CH4	N2O	CO2e
Architectural Coating	0.0000					0.0000	0.0000	0.0000	0.0000	0.0000	0.0000	0.0000	0.0000	0.0000	0.0000	0.0000
Consumer Products	0.0000					0.0000	0.0000	0.0000	0.0000	0.0000	0.0000	0.0000	0.0000	0.0000	0.0000	0.0000
Landscaping	0.0000	0.0000	1.0000e-005	0.0000		0.0000	0.0000	0.0000	0.0000	0.0000	0.0000	2.0000e-005	2.0000e-005	0.0000	0.0000	2.0000e-005
Total	0.0000	0.0000	1.0000e-005	0.0000		0.0000	0.0000	0.0000	0.0000	0.0000	0.0000	2.0000e-005	2.0000e-005	0.0000	0.0000	2.0000e-005

7.0 Water Detail

7.1 Mitigation Measures Water

	Total CO2	CH4	N2O	CO2e
Category	MT/yr			
Mitigated	0.0000	0.0000	0.0000	0.0000
Unmitigated	0.0000	0.0000	0.0000	0.0000

7.2 Water by Land Use

Unmitigated

	Indoor/Outdoor Use	Total CO2	CH4	N2O	CO2e
Land Use	Mgal				
User Defined Industrial	0 / 0	0.0000	0.0000	0.0000	0.0000
Total		0.0000	0.0000	0.0000	0.0000

BCTD DB-128R2 - San Francisco County, Annual

7.2 Water by Land Use

Mitigated

Land Use	Indoor/Outdoor Use	Total CO2	CH4	N2O	CO2e
	Mgal	MT/yr			
User Defined Industrial	0 / 0	0.0000	0.0000	0.0000	0.0000
Total		0.0000	0.0000	0.0000	0.0000

8.0 Waste Detail

8.1 Mitigation Measures Waste

Category/Year

Category/Year	Total CO2	CH4	N2O	CO2e
	MT/yr			
Mitigated	0.0000	0.0000	0.0000	0.0000
Unmitigated	0.0000	0.0000	0.0000	0.0000

BCTD DB-128R2 - San Francisco County, Annual

8.2 Waste by Land Use

Unmitigated

Land Use	Waste Disposed tons	Total CO2				CO2e
		CH4	N2O	MT/yr		
User Defined Industrial	0	0.0000	0.0000	0.0000	0.0000	0.0000
Total		0.0000	0.0000	0.0000	0.0000	0.0000

Mitigated

Land Use	Waste Disposed tons	Total CO2				CO2e
		CH4	N2O	MT/yr		
User Defined Industrial	0	0.0000	0.0000	0.0000	0.0000	0.0000
Total		0.0000	0.0000	0.0000	0.0000	0.0000

9.0 Operational Offroad

Equipment Type	Number	Hours/Day	Days/Year	Horse Power	Load Factor	Fuel Type
----------------	--------	-----------	-----------	-------------	-------------	-----------

10.0 Stationary Equipment

Fire Pumps and Emergency Generators

Equipment Type	Number	Hours/Day	Hours/Year	Horse Power	Load Factor	Fuel Type
----------------	--------	-----------	------------	-------------	-------------	-----------

Boilers

Equipment Type	Number	Heat Input/Day	Heat Input/Year	Boiler Rating	Fuel Type
----------------	--------	----------------	-----------------	---------------	-----------

User Defined Equipment

Equipment Type	Number
----------------	--------

11.0 Vegetation

BCTD DB-128R2 - San Francisco County, Annual

BCTD DB-128R2

San Francisco County, Annual

1.0 Project Characteristics

1.1 Land Usage

Land Uses	Size	Metric	Lot Acreage	Floor Surface Area	Population
User Defined Industrial	1.00	User Defined Unit	2.50	0.00	0

1.2 Other Project Characteristics

Urbanization	Urban	Wind Speed (m/s)	4.6	Precipitation Freq (Days)	64
Climate Zone	5			Operational Year	2020

Utility Company Pacific Gas & Electric Company

CO2 Intensity (lb/MW/hr)	641.35	CH4 Intensity (lb/MW/hr)	0.029	N2O Intensity (lb/MW/hr)	0.006
---------------------------------	--------	---------------------------------	-------	---------------------------------	-------

1.3 User Entered Comments & Non-Default Data

Project Characteristics -

Land Use - Project acreage based on trenching limits from Construction Length and Phasing Map, assuming 15 ft width.

Construction Phase - Project specific construction schedule.

Off-road Equipment - Project specific equipment. Off highway truck to account for asphalt truck. Other construction equipment to account for jackhammer.

Grading - Based on material excavation (expanded): 9,711 CY; material backfill: 7,355 CY.

Trips and VMT - Based on 15 workers per day, 4 concrete daily truck trips (modeled as vendor trips), and total haul trips based on 16 CY capacity dump truck. Default miles.

Construction Off-road Equipment Mitigation - Watering twice per day in accordance with BAAQMD BMPs. Diesel Tier 4 Final Engines. Generator assumed to be electrical.

BCTD DB-128R2 - San Francisco County, Annual

Table Name	Column Name	Default Value	New Value
tblConstEquipMitigation	FuelType	Diesel	Electrical
tblConstEquipMitigation	NumberOfEquipmentMitigated	0.00	1.00
tblConstEquipMitigation	NumberOfEquipmentMitigated	0.00	1.00
tblConstEquipMitigation	NumberOfEquipmentMitigated	0.00	1.00
tblConstEquipMitigation	NumberOfEquipmentMitigated	0.00	1.00
tblConstEquipMitigation	NumberOfEquipmentMitigated	0.00	2.00
tblConstEquipMitigation	NumberOfEquipmentMitigated	0.00	1.00
tblConstEquipMitigation	NumberOfEquipmentMitigated	0.00	1.00
tblConstEquipMitigation	Tier	No Change	Tier 4 Final
tblConstEquipMitigation	Tier	No Change	Tier 4 Final
tblConstEquipMitigation	Tier	No Change	Tier 4 Final
tblConstEquipMitigation	Tier	No Change	Tier 4 Final
tblConstEquipMitigation	Tier	No Change	Tier 4 Final
tblConstEquipMitigation	Tier	No Change	Tier 4 Final
tblConstEquipMitigation	Tier	No Change	Tier 4 Final
tblConstructionPhase	NumDays	6.00	218.00
tblConstructionPhase	PhaseEndDate	4/10/2019	12/31/2019
tblConstructionPhase	PhaseStartDate	4/3/2019	3/1/2019
tblGrading	MaterialExported	0.00	9,711.00
tblGrading	MaterialImported	0.00	7,355.00
tblLandUse	LotAcreage	0.00	2.50
tblOffRoadEquipment	LoadFactor	0.38	0.38
tblOffRoadEquipment	LoadFactor	0.42	0.42
tblOffRoadEquipment	LoadFactor	0.37	0.37
tblOffRoadEquipment	LoadFactor	0.38	0.38
tblOffRoadEquipment	LoadFactor	0.38	0.38

BCTD DB-128R2 - San Francisco County, Annual

tbIOffRoadEquipment	OffRoadEquipmentType	Excavators	
tbIOffRoadEquipment	OffRoadEquipmentType	Other Construction Equipment	
tbIOffRoadEquipment	OffRoadEquipmentType	Concrete/Industrial Saws	
tbIOffRoadEquipment	OffRoadEquipmentType	Generator Sets	
tbIOffRoadEquipment	OffRoadEquipmentType	Skid Steer Loaders	
tbIOffRoadEquipment	OffRoadEquipmentType	Off-Highway Trucks	
tbIOffRoadEquipment	OffRoadEquipmentType	Rollers	
tbIOffRoadEquipment	OffRoadEquipmentUnitAmount		1.00
tbIOffRoadEquipment	OffRoadEquipmentUnitAmount		2.00
tbIOffRoadEquipment	OffRoadEquipmentUnitAmount		1.00
tbIOffRoadEquipment	UsageHours		8.00
tbIOffRoadEquipment	UsageHours		7.00
tbIOffRoadEquipment	UsageHours		8.00
tbITripsAndVMT	VendorTripNumber		0.00
tbITripsAndVMT	WorkerTripNumber		20.00
			0.00
			8.00
			30.00

2.0 Emissions Summary

BCTD DB-128R2 - San Francisco County, Annual

2.1 Overall Construction

Unmitigated Construction

Year	tons/yr											MT/yr				
	ROG	NOx	CO	SO2	Fugitive PM10	Exhaust PM10	PM10 Total	Fugitive PM2.5	Exhaust PM2.5	PM2.5 Total	Bio- CO2	NBio- CO2	Total CO2	CH4	N2O	CO2e
2019	0.3763	3.9939	3.0834	6.6900e-003	0.0520	0.1805	0.2324	0.0138	0.1701	0.1839	0.0000	612.7234	612.7234	0.1383	0.0000	616.1815
Maximum	0.3763	3.9939	3.0834	6.6900e-003	0.0520	0.1805	0.2324	0.0138	0.1701	0.1839	0.0000	612.7234	612.7234	0.1383	0.0000	616.1815

Mitigated Construction

Year	tons/yr											MT/yr				
	ROG	NOx	CO	SO2	Fugitive PM10	Exhaust PM10	PM10 Total	Fugitive PM2.5	Exhaust PM2.5	PM2.5 Total	Bio- CO2	NBio- CO2	Total CO2	CH4	N2O	CO2e
2019	0.0814	0.8774	3.1275	6.6900e-003	0.0506	9.6900e-003	0.0603	0.0136	9.5700e-003	0.0232	0.0000	551.1153	551.1153	0.1344	0.0000	554.4759
Maximum	0.0814	0.8774	3.1275	6.6900e-003	0.0506	9.6900e-003	0.0603	0.0136	9.5700e-003	0.0232	0.0000	551.1153	551.1153	0.1344	0.0000	554.4759

Percent Reduction	ROG	NOx	CO	SO2	Fugitive PM10	Exhaust PM10	PM10 Total	Fugitive PM2.5	Exhaust PM2.5	PM2.5 Total	Bio- CO2	NBio- CO2	Total CO2	CH4	N2O	CO2e
	78.37	78.03	-1.43	0.00	2.68	94.63	74.08	1.52	94.37	87.40	0.00	10.05	10.05	2.82	0.00	10.01

BCTD DB-128R2 - San Francisco County, Annual

Quarter	Start Date	End Date	Maximum Unmitigated ROG + NOX (tons/quarter)	Maximum Mitigated ROG + NOX (tons/quarter)
1	3-1-2019	5-31-2019	1.3151	0.2868
2	6-1-2019	8-31-2019	1.3134	0.2850
3	9-1-2019	9-30-2019	0.4283	0.0929
		Highest	1.3151	0.2868

**2.2 Overall Operational
Unmitigated Operational**

Category	tons/yr											MT/yr				
	ROG	NOx	CO	SO2	Fugitive PM10	Exhaust PM10	PM10 Total	Fugitive PM2.5	Exhaust PM2.5	PM2.5 Total	Bio- CO2	NBio- CO2	Total CO2	CH4	N2O	CO2e
Area	0.0000	0.0000	1.0000e-005	0.0000	0.0000	0.0000	0.0000	0.0000	0.0000	0.0000	0.0000	2.0000e-005	2.0000e-005	0.0000	0.0000	2.0000e-005
Energy	0.0000	0.0000	0.0000	0.0000	0.0000	0.0000	0.0000	0.0000	0.0000	0.0000	0.0000	0.0000	0.0000	0.0000	0.0000	0.0000
Mobile	0.0000	0.0000	0.0000	0.0000	0.0000	0.0000	0.0000	0.0000	0.0000	0.0000	0.0000	0.0000	0.0000	0.0000	0.0000	0.0000
Waste																
Water																
Total	0.0000	0.0000	1.0000e-005	0.0000	0.0000	0.0000	0.0000	0.0000	0.0000	0.0000	0.0000	2.0000e-005	2.0000e-005	0.0000	0.0000	2.0000e-005

BCTD DB-128R2 - San Francisco County, Annual

2.2 Overall Operational

Mitigated Operational

Category	tons/yr											MT/yr				
	ROG	NOx	CO	SO2	Fugitive PM10	Exhaust PM10	PM10 Total	Fugitive PM2.5	Exhaust PM2.5	PM2.5 Total	Bio- CO2	NBio- CO2	Total CO2	CH4	N2O	CO2e
Area	0.0000	0.0000	1.0000e-005	0.0000	0.0000	0.0000	0.0000	0.0000	0.0000	0.0000	0.0000	2.0000e-005	2.0000e-005	0.0000	0.0000	2.0000e-005
Energy	0.0000	0.0000	0.0000	0.0000	0.0000	0.0000	0.0000	0.0000	0.0000	0.0000	0.0000	0.0000	0.0000	0.0000	0.0000	0.0000
Mobile	0.0000	0.0000	0.0000	0.0000	0.0000	0.0000	0.0000	0.0000	0.0000	0.0000	0.0000	0.0000	0.0000	0.0000	0.0000	0.0000
Waste	0.0000	0.0000	0.0000	0.0000	0.0000	0.0000	0.0000	0.0000	0.0000	0.0000	0.0000	0.0000	0.0000	0.0000	0.0000	0.0000
Water	0.0000	0.0000	0.0000	0.0000	0.0000	0.0000	0.0000	0.0000	0.0000	0.0000	0.0000	0.0000	0.0000	0.0000	0.0000	0.0000
Total	0.0000	0.0000	1.0000e-005	0.0000	0.0000	0.0000	0.0000	0.0000	0.0000	0.0000	0.0000	2.0000e-005	2.0000e-005	0.0000	0.0000	2.0000e-005

Percent Reduction	tons/yr											MT/yr				
	ROG	NOx	CO	SO2	Fugitive PM10	Exhaust PM10	PM10 Total	Fugitive PM2.5	Exhaust PM2.5	PM2.5 Total	Bio- CO2	NBio- CO2	Total CO2	CH4	N2O	CO2e
0.00	0.00	0.00	0.00	0.00	0.00	0.00	0.00	0.00	0.00	0.00	0.00	0.00	0.00	0.00	0.00	0.00

3.0 Construction Detail

Construction Phase

Phase Number	Phase Name	Phase Type	Start Date	End Date	Num Days Week	Num Days	Phase Description
1	Trenching	Grading	3/1/2019	12/31/2019	5	218	

Acres of Grading (Site Preparation Phase): 0

BCTD DB-128R2 - San Francisco County, Annual

Acres of Grading (Grading Phase): 0

Acres of Paving: 0

Residential Indoor: 0; Residential Outdoor: 0; Non-Residential Indoor: 0; Non-Residential Outdoor: 0; Striped Parking Area: 0 (Architectural Coating – sqft)

OffRoad Equipment

Phase Name	Offroad Equipment Type	Amount	Usage Hours	Horse Power	Load Factor
Trenching	Excavators	1	8.00	158	0.38
Trenching	Other Construction Equipment	2	8.00	172	0.42
Trenching	Concrete/Industrial Saws	1	8.00	81	0.73
Trenching	Generator Sets	1	8.00	84	0.74
Trenching	Skid Steer Loaders	1	8.00	65	0.37
Trenching	Off-Highway Trucks	1	8.00	402	0.38
Trenching	Rollers	1	8.00	80	0.38
Trenching	Rubber Tired Dozers	0	0.00	247	0.40
Trenching	Tractors/Loaders/Backhoes	0	0.00	97	0.37
Trenching	Graders	0	0.00	187	0.41

Trips and VMT

Phase Name	Offroad Equipment Count	Worker Trip Number	Vendor Trip Number	Hauling Trip Number	Worker Trip Length	Vendor Trip Length	Hauling Trip Length	Worker Vehicle Class	Vendor Vehicle Class	Hauling Vehicle Class
Trenching	8	30.00	8.00	2,133.00	10.80	7.30	20.00	LD_Mix	HDT_Mix	HHDT

3.1 Mitigation Measures Construction

- Use Alternative Fuel for Construction Equipment
- Use Cleaner Engines for Construction Equipment
- Water Exposed Area

BCTD DB-128R2 - San Francisco County, Annual

3.2 Trenching - 2019

Unmitigated Construction On-Site

Category	ROG	NOx	CO	SO2	Fugitive PM10	Exhaust PM10	PM10 Total	Fugitive PM2.5	Exhaust PM2.5	PM2.5 Total	Bio- CO2	NBio- CO2	Total CO2	CH4	N2O	CO2e
	tons/yr															
	MT/yr															
Fugitive Dust	0.3518	3.4656	2.8553	5.2500e-003	2.5200e-003	0.0000	2.5200e-003	3.8000e-004	0.0000	3.8000e-004	0.0000	0.0000	0.0000	0.0000	0.0000	0.0000
Off-Road	0.3518	3.4656	2.8553	5.2500e-003	0.1780	0.1780	0.1780	0.1678	0.1678	0.1678	0.0000	466.2056	466.2056	0.1175	0.0000	469.1430
Total	0.3518	3.4656	2.8553	5.2500e-003	2.5200e-003	0.1780	0.1806	3.8000e-004	0.1678	0.1681	0.0000	466.2056	466.2056	0.1175	0.0000	469.1430

Unmitigated Construction Off-Site

Category	ROG	NOx	CO	SO2	Fugitive PM10	Exhaust PM10	PM10 Total	Fugitive PM2.5	Exhaust PM2.5	PM2.5 Total	Bio- CO2	NBio- CO2	Total CO2	CH4	N2O	CO2e
	tons/yr															
	MT/yr															
Hauling	9.7600e-003	0.4020	0.1122	9.2000e-004	0.0179	1.5200e-003	0.0194	4.9100e-003	1.4600e-003	6.3700e-003	0.0000	96.7670	96.7670	0.0169	0.0000	97.1904
Vendor	3.9400e-003	0.1190	0.0353	2.4000e-004	5.7000e-003	7.4000e-004	6.4400e-003	1.6500e-003	7.0000e-004	2.3500e-003	0.0000	24.3798	24.3798	3.2900e-003	0.0000	24.4620
Worker	0.0107	7.4100e-003	0.0806	2.8000e-004	0.0258	2.0000e-004	0.0260	6.8700e-003	1.8000e-004	7.0600e-003	0.0000	25.3710	25.3710	6.0000e-004	0.0000	25.3861
Total	0.0244	0.5283	0.2281	1.4400e-003	0.0494	2.4600e-003	0.0519	0.0134	2.3400e-003	0.0158	0.0000	146.5179	146.5179	0.0208	0.0000	147.0386

BCTD DB-128R2 - San Francisco County, Annual

3.2 Trenching - 2019

Mitigated Construction On-Site

Category	tons/yr											MT/yr					
	ROG	NOx	CO	SO2	Fugitive PM10	Exhaust PM10	PM10 Total	Fugitive PM2.5	Exhaust PM2.5	PM2.5 Total	Bio- CO2	NBio- CO2	Total CO2	CH4	N2O	CO2e	
Fugitive Dust					1.1300e-003	0.0000	1.1300e-003	1.7000e-004	0.0000	1.7000e-004	0.0000	0.0000	0.0000	0.0000	0.0000	0.0000	0.0000
Off-Road	0.0570	0.3491	2.8994	5.2500e-003	7.2300e-003	7.2300e-003	7.2300e-003	7.2300e-003	7.2300e-003	7.2300e-003	0.0000	404.5975	404.5975	0.1136	0.0000	407.4373	
Total	0.0570	0.3491	2.8994	5.2500e-003	1.1300e-003	7.2300e-003	8.3600e-003	1.7000e-004	7.2300e-003	7.4000e-003	0.0000	404.5975	404.5975	0.1136	0.0000	407.4373	

Mitigated Construction Off-Site

Category	tons/yr											MT/yr				
	ROG	NOx	CO	SO2	Fugitive PM10	Exhaust PM10	PM10 Total	Fugitive PM2.5	Exhaust PM2.5	PM2.5 Total	Bio- CO2	NBio- CO2	Total CO2	CH4	N2O	CO2e
Hauling	9.7600e-003	0.4020	0.1122	9.2000e-004	0.0179	1.5200e-003	0.0194	4.9100e-003	1.4600e-003	6.3700e-003	0.0000	96.7670	96.7670	0.0169	0.0000	97.1904
Vendor	3.9400e-003	0.1190	0.0353	2.4000e-004	5.7000e-003	7.4000e-004	6.4400e-003	1.6500e-003	7.0000e-004	2.3500e-003	0.0000	24.3798	24.3798	3.2900e-003	0.0000	24.4620
Worker	0.0107	7.4100e-003	0.0806	2.8000e-004	0.0258	2.0000e-004	0.0260	6.8700e-003	1.8000e-004	7.0600e-003	0.0000	25.3710	25.3710	6.0000e-004	0.0000	25.3861
Total	0.0244	0.5283	0.2281	1.4400e-003	0.0494	2.4600e-003	0.0519	0.0134	2.3400e-003	0.0158	0.0000	146.5179	146.5179	0.0208	0.0000	147.0386

4.0 Operational Detail - Mobile

BCTD DB-128R2 - San Francisco County, Annual

4.1 Mitigation Measures Mobile

Category	tons/yr										MT/yr					
	ROG	NOx	CO	SO2	Fugitive PM10	Exhaust PM10	PM10 Total	Fugitive PM2.5	Exhaust PM2.5	PM2.5 Total	Bio- CO2	NBio- CO2	Total CO2	CH4	N2O	CO2e
Mitigated	0.0000	0.0000	0.0000	0.0000	0.0000	0.0000	0.0000	0.0000	0.0000	0.0000	0.0000	0.0000	0.0000	0.0000	0.0000	0.0000
Unmitigated	0.0000	0.0000	0.0000	0.0000	0.0000	0.0000	0.0000	0.0000	0.0000	0.0000	0.0000	0.0000	0.0000	0.0000	0.0000	0.0000

4.2 Trip Summary Information

Land Use	Average Daily Trip Rate			Unmitigated Annual VMT	Mitigated Annual VMT
	Weekday	Saturday	Sunday		
User Defined Industrial	0.00	0.00	0.00		
Total	0.00	0.00	0.00		

4.3 Trip Type Information

Land Use	Miles				Trip %				Trip Purpose %			
	H-W or C-W	H-O or C-NW	H-S or C-C	H-O or C-NW	H-W or C-W	H-S or C-C	H-O or C-NW	H-O or C-NW	Primary	Diverted	Pass-by	
User Defined Industrial	9.50	7.30	7.30	7.30	0.00	0.00	0.00	0.00	0	0	0	

4.4 Fleet Mix

Land Use	LDA	LDT1	LDT2	MDV	LHD1	LHD2	MHD	HHD	OBUS	UBUS	MCY	SBUS	MH
User Defined Industrial	0.607015	0.041018	0.191033	0.097570	0.015386	0.004865	0.027149	0.008727	0.004280	0.004624	0.006947	0.000926	0.000460

BCTD DB-128R2 - San Francisco County, Annual

5.3 Energy by Land Use - Electricity

Unmitigated

Land Use	Electricity Use	Total CO2	CH4	N2O	CO2e
	kWh/yr	MT/yr			
User Defined Industrial	0	0.0000	0.0000	0.0000	0.0000
Total		0.0000	0.0000	0.0000	0.0000

Mitigated

Land Use	Electricity Use	Total CO2	CH4	N2O	CO2e
	kWh/yr	MT/yr			
User Defined Industrial	0	0.0000	0.0000	0.0000	0.0000
Total		0.0000	0.0000	0.0000	0.0000

6.0 Area Detail

6.1 Mitigation Measures Area

BCTD DB-128R2 - San Francisco County, Annual

Category	ROG	NOx	CO	SO2	Fugitive PM10	Exhaust PM10	PM10 Total	Fugitive PM2.5	Exhaust PM2.5	PM2.5 Total	Bio- CO2	NBio- CO2	Total CO2	CH4	N2O	CO2e	
tons/yr																	
MT/yr																	
Mitigated	0.0000	0.0000	1.0000e-005	0.0000	0.0000	0.0000	0.0000	0.0000	0.0000	0.0000	0.0000	2.0000e-005	2.0000e-005	0.0000	0.0000	0.0000	2.0000e-005
Unmitigated	0.0000	0.0000	1.0000e-005	0.0000	0.0000	0.0000	0.0000	0.0000	0.0000	0.0000	0.0000	2.0000e-005	2.0000e-005	0.0000	0.0000	0.0000	2.0000e-005

6.2 Area by SubCategory

Unmitigated

SubCategory	ROG	NOx	CO	SO2	Fugitive PM10	Exhaust PM10	PM10 Total	Fugitive PM2.5	Exhaust PM2.5	PM2.5 Total	Bio- CO2	NBio- CO2	Total CO2	CH4	N2O	CO2e	
tons/yr																	
MT/yr																	
Architectural Coating	0.0000					0.0000	0.0000		0.0000	0.0000	0.0000	0.0000	0.0000	0.0000	0.0000	0.0000	0.0000
Consumer Products	0.0000					0.0000	0.0000		0.0000	0.0000	0.0000	0.0000	0.0000	0.0000	0.0000	0.0000	0.0000
Landscaping	0.0000	0.0000	1.0000e-005	0.0000		0.0000	0.0000		0.0000	0.0000	0.0000	2.0000e-005	2.0000e-005	0.0000	0.0000	0.0000	2.0000e-005
Total	0.0000	0.0000	1.0000e-005	0.0000		0.0000	0.0000		0.0000	0.0000	0.0000	2.0000e-005	2.0000e-005	0.0000	0.0000	0.0000	2.0000e-005

BCTD DB-128R2 - San Francisco County, Annual

6.2 Area by SubCategory

Mitigated

SubCategory	tons/yr										MT/yr						
	ROG	NOx	CO	SO2	Fugitive PM10	Exhaust PM10	PM10 Total	Fugitive PM2.5	Exhaust PM2.5	PM2.5 Total	Bio- CO2	NBio- CO2	Total CO2	CH4	N2O	CO2e	
Architectural Coating	0.0000					0.0000	0.0000	0.0000	0.0000	0.0000	0.0000	0.0000	0.0000	0.0000	0.0000	0.0000	0.0000
Consumer Products	0.0000					0.0000	0.0000	0.0000	0.0000	0.0000	0.0000	0.0000	0.0000	0.0000	0.0000	0.0000	0.0000
Landscaping	0.0000	0.0000	1.0000e-005	0.0000		0.0000	0.0000	0.0000	0.0000	0.0000	0.0000	2.0000e-005	2.0000e-005	0.0000	0.0000	0.0000	2.0000e-005
Total	0.0000	0.0000	1.0000e-005	0.0000		0.0000	0.0000	0.0000	0.0000	0.0000	0.0000	2.0000e-005	2.0000e-005	0.0000	0.0000	0.0000	2.0000e-005

7.0 Water Detail

7.1 Mitigation Measures Water

BCTD DB-128R2 - San Francisco County, Annual

	Total CO2	CH4	N2O	CO2e
Category	MT/yr			
Mitigated	0.0000	0.0000	0.0000	0.0000
Unmitigated	0.0000	0.0000	0.0000	0.0000

7.2 Water by Land Use

Unmitigated

	Indoor/Outdoor Use	Total CO2	CH4	N2O	CO2e
Land Use	Mgal	MT/yr			
User Defined Industrial	0 / 0	0.0000	0.0000	0.0000	0.0000
Total		0.0000	0.0000	0.0000	0.0000

BCTD DB-128R2 - San Francisco County, Annual

7.2 Water by Land Use

Mitigated

Land Use	Indoor/Outdoor Use	Total CO2	CH4	N2O	CO2e
	Mgal	MT/yr			
User Defined Industrial	0 / 0	0.0000	0.0000	0.0000	0.0000
Total		0.0000	0.0000	0.0000	0.0000

8.0 Waste Detail

8.1 Mitigation Measures Waste

Category/Year

Category/Year	Total CO2	CH4	N2O	CO2e
	MT/yr			
Mitigated	0.0000	0.0000	0.0000	0.0000
Unmitigated	0.0000	0.0000	0.0000	0.0000

BCTD DB-128R2 - San Francisco County, Annual

8.2 Waste by Land Use

Unmitigated

Land Use	Waste Disposed tons	Total CO2				CO2e
		CH4	N2O	MT/yr		
User Defined Industrial	0	0.0000	0.0000	0.0000	0.0000	0.0000
Total		0.0000	0.0000	0.0000	0.0000	0.0000

Mitigated

Land Use	Waste Disposed tons	Total CO2				CO2e
		CH4	N2O	MT/yr		
User Defined Industrial	0	0.0000	0.0000	0.0000	0.0000	0.0000
Total		0.0000	0.0000	0.0000	0.0000	0.0000

9.0 Operational Offroad

Equipment Type	Number	Hours/Day	Days/Year	Horse Power	Load Factor	Fuel Type
----------------	--------	-----------	-----------	-------------	-------------	-----------

BCTD DB-128R2 - San Francisco County, Annual

10.0 Stationary Equipment

Fire Pumps and Emergency Generators

Equipment Type	Number	Hours/Day	Hours/Year	Horse Power	Load Factor	Fuel Type
----------------	--------	-----------	------------	-------------	-------------	-----------

Boilers

Equipment Type	Number	Heat Input/Day	Heat Input/Year	Boiler Rating	Fuel Type
----------------	--------	----------------	-----------------	---------------	-----------

User Defined Equipment

Equipment Type	Number
----------------	--------

11.0 Vegetation

From: [Balenzuela, Justin](#)
To: [BOS Legislation, \(BOS\)](#)
Cc: [Scarpulla, John \(PUC\)](#); [CHO, THERESA \(CAT\)](#)
Subject: SFPUC - [Approving Transmission Facilities Agreement - Public Utilities Commission]
Date: Tuesday, February 2, 2021 2:42:23 PM
Attachments: [4. Draft TFA Contract Agreement.docx](#)
[1. Proposed TFA Ordinance.docx](#)
[2. Proposed TFA Ordinance.pdf](#)
[3. Legislative Digest.docx](#)
[5. Cover Letter.docx](#)

Hi BOS Legislative Team,

Attached is the proposed legislation concerning “Ordinance approving a Transmission Facilities Agreement with Pacific Gas and Electric Company for a total cost of \$21,165,000 and a term of 4.5 years, and waiving certain provisions of the Administrative and Environment Codes.”

The electronic attachments are listed below:

1. Proposed TFA Ordinance (Word Doc Version)
2. Proposed TFA Ordinance (Signed PDF Version)
3. Legislative Digest
4. Draft TFA Contract Agreement
5. Cover Letter

Staff Contact: [John Scarpulla, Policy & Government Affairs Local Manager] [415-509-3070]

Thank you,
Justin Balenzuela
Policy & Government Affairs
San Francisco Public Utilities Commission
JBalenzuela@sfgwater.org | 628.800.4355

From: [Scarpulla, John](#)
To: [Wong, Linda \(BOS\)](#)
Cc: [CHO, THERESA \(CAT\)](#)
Subject: RE: Request for Document - File No. 210159 - PG&E - Transmission Facilities Agreement
Date: Monday, March 29, 2021 2:05:53 PM
Attachments: [2019-013330ENV.pdf](#)

Hi Linda,

Please see attached for the CEQA Document.

The term and not-to-exceed amount isn't explicitly stated in the TFA itself, but has to be calculated based on the termination date of the City's Transmission Interconnection Agreement. As explained on page 2 of the Legislative digest, the Transmission Interconnection Agreement expires on June 30, 2025. With regard to the term of the TFA, Section 15 of the TFA states in the second sentence "... this TFA shall remain in force and for the duration of the existing CCSF TIA..." Therefore, the term of the TFA expires on June 30, 2025.

The cost is in Exhibit B, pages 16-17 of the TFA. The net cost of the upgrades is \$13,850,000 (Exhibit B, Section II) and the Monthly Cost of Ownership Charge is \$57,000/month (Exhibit B, Section III). As explain in the Legislative Digest, the monthly charges will commence after the transmission project is energized in October 2021, which results in 45 months of monthly charges through June 2025, for a total amount of \$2,565,000 in monthly charges, and a total contract amount of \$21,165,000 for the cost of the upgrades and the monthly charges.

I've cc'd Theresa Cho the City Attorney for this one in case you have follow-up questions on the above.

Thanks!

-John

From: Scarpulla, John
Sent: Monday, March 29, 2021 11:43 AM
To: Wong, Linda (BOS) <linda.wong@sfgov.org>
Subject: RE: Request for Document - File No. 210159 - PG&E - Transmission Facilities Agreement

Hi Linda,

Will get you this info/document ASAP!

Best,
John

From: Wong, Linda (BOS) <linda.wong@sfgov.org>
Sent: Monday, March 29, 2021 11:39 AM

To: Scarpulla, John <JScarpulla@sfgov.org>

Subject: Request for Document - File No. 210159 - PG&E - Transmission Facilities Agreement

CAUTION: This email originated from **outside** of the organization. Do not click links or open attachments unless you recognize the sender and know the content is safe.

Hi John,

Could you please provide me with a copy of the CEQA Determination from Planning on October 24, 2019 mentioned in the attached ordinance?

Also, where can I find the term dates and the agreement amount of \$21,165,000 in the TFA?

Best,

Linda Wong

San Francisco Board of Supervisors

1 Dr. Carlton B. Goodlett Place, City Hall, Room 244

San Francisco, CA 94102-4689

Phone: 415.554.7719 | Fax: (415) 554-5163

Linda.Wong@sfgov.org | www.sfbos.org

Please complete a Board of Supervisors Customer Service Satisfaction form by clicking [here](#).

The [Legislative Research Center](#) provides 24-hour access to Board of Supervisors legislation, and archived matters since August 1998.

***Disclosures:** Personal information that is provided in communications to the Board of Supervisors is subject to disclosure under the California Public Records Act and the San Francisco Sunshine Ordinance. Personal information provided will not be redacted. Members of the public are not required to provide personal identifying information when they communicate with the Board of Supervisors and its committees. All written or oral communications that members of the public submit to the Clerk's Office regarding pending legislation or hearings will be made available to all members of the public for inspection and copying. The Clerk's Office does not redact any information from these submissions. This means that personal information—including names, phone numbers, addresses and similar information that a member of the public elects to submit to the Board and its committees—may appear on the Board of Supervisors website or in other public documents that members of the public may inspect or copy.*



San Francisco Ethics Commission

25 Van Ness Avenue, Suite 220, San Francisco, CA 94102

Phone: 415.252.3100 . Fax: 415.252.3112

ethics.commission@sfgov.org . www.sfethics.org

Received On:

File #: 210159

Bid/RFP #:

Notification of Contract Approval

SFEC Form 126(f)4

(S.F. Campaign and Governmental Conduct Code § 1.126(f)4)

A Public Document

Each City elective officer who approves a contract that has a total anticipated or actual value of \$100,000 or more must file this form with the Ethics Commission within five business days of approval by: (a) the City elective officer, (b) any board on which the City elective officer serves, or (c) the board of any state agency on which an appointee of the City elective officer serves. For more information, see: <https://sfethics.org/compliance/city-officers/contract-approval-city-officers>

1. FILING INFORMATION

TYPE OF FILING	DATE OF ORIGINAL FILING (for amendment only)
Original	
AMENDMENT DESCRIPTION – Explain reason for amendment	

2. CITY ELECTIVE OFFICE OR BOARD

OFFICE OR BOARD	NAME OF CITY ELECTIVE OFFICER
Board of Supervisors	Members

3. FILER'S CONTACT

NAME OF FILER'S CONTACT	TELEPHONE NUMBER
Angela Calvillo	415-554-5184
FULL DEPARTMENT NAME	EMAIL
office of the clerk of the Board	Board.of.Supervisors@sfgov.org

4. CONTRACTING DEPARTMENT CONTACT

NAME OF DEPARTMENTAL CONTACT	DEPARTMENT CONTACT TELEPHONE NUMBER
Justin Balenzuela	415-934-3908
FULL DEPARTMENT NAME	DEPARTMENT CONTACT EMAIL
PUC Public Utilities Commission	jbalenzuela@sfgwater.org

5. CONTRACTOR	
NAME OF CONTRACTOR Pacific Gas and Electric Company	TELEPHONE NUMBER 415-973-1000
STREET ADDRESS (including City, State and Zip Code) 77 Beale Street, San Francisco, CA 94105	EMAIL

6. CONTRACT		
DATE CONTRACT WAS APPROVED BY THE CITY ELECTIVE OFFICER(S)	ORIGINAL BID/RFP NUMBER	FILE NUMBER (If applicable) 210159
DESCRIPTION OF AMOUNT OF CONTRACT \$21,165,000		
NATURE OF THE CONTRACT (Please describe) Transmission Facilities Agreement with Pacific Gas and Electric Company to interconnect City-owned transmission facilities to the electric grid for a total cost of \$21,165,000 and a term of four years and three months commencing in April 2021 and ending in June 2025, and waiving certain provisions of the Administrative and Environment Codes.		

7. COMMENTS

8. CONTRACT APPROVAL	
This contract was approved by:	
<input type="checkbox"/>	THE CITY ELECTIVE OFFICER(S) IDENTIFIED ON THIS FORM
<input checked="" type="checkbox"/>	A BOARD ON WHICH THE CITY ELECTIVE OFFICER(S) SERVES Board of Supervisors
<input type="checkbox"/>	THE BOARD OF A STATE AGENCY ON WHICH AN APPOINTEE OF THE CITY ELECTIVE OFFICER(S) IDENTIFIED ON THIS FORM SITS

9. AFFILIATES AND SUBCONTRACTORS

List the names of (A) members of the contractor's board of directors; (B) the contractor's principal officers, including chief executive officer, chief financial officer, chief operating officer, or other persons with similar titles; (C) any individual or entity who has an ownership interest of 10 percent or more in the contractor; and (D) any subcontractor listed in the bid or contract.

#	LAST NAME/ENTITY/SUBCONTRACTOR	FIRST NAME	TYPE
1	Poppe	Patricia K.	CEO
2	Wright	Adam L.	COO
3	Foster	Chris	CFO
4	Cox	Julius	Other Principal Officer
5	Simon	John R.	Other Principal Officer
6	Benavides	Francisco	Other Principal Officer
7	Singh	Sumeet	Other Principal Officer
8	waghray	Ajay	Other Principal Officer
9	Cairns	Stephen J.	Other Principal Officer
10	Bahri	Rajat	Board of Directors
11	Campbell	Cheryl F.	Board of Directors
12	Cooper	Kerry W.	Board of Directors
13	Denecour	Jessica L.	Board of Directors
14	Ferguson	Mark E.	Board of Directors
15	Flexon	Robert C.	Board of Directors
16	Fugate	Craig	Board of Directors
17	Harris	Arno L.	Board of Directors
18	Smith	William L.	Board of Directors
19	Treseder	Dara J.	Board of Directors

9. AFFILIATES AND SUBCONTRACTORS

List the names of (A) members of the contractor’s board of directors; (B) the contractor’s principal officers, including chief executive officer, chief financial officer, chief operating officer, or other persons with similar titles; (C) any individual or entity who has an ownership interest of 10 percent or more in the contractor; and (D) any subcontractor listed in the bid or contract.

#	LAST NAME/ENTITY/SUBCONTRACTOR	FIRST NAME	TYPE
20	wilson	Benjamin F.	Board of Directors
21	woolard	John M.	Board of Directors
22	Seavers	Dean L.	Board of Directors
23	Niggli	Michael R.	Board of Directors
24			
25			
26			
27			
28			
29			
30			
31			
32			
33			
34			
35			
36			
37			
38			

9. AFFILIATES AND SUBCONTRACTORS

List the names of (A) members of the contractor’s board of directors; (B) the contractor’s principal officers, including chief executive officer, chief financial officer, chief operating officer, or other persons with similar titles; (C) any individual or entity who has an ownership interest of 10 percent or more in the contractor; and (D) any subcontractor listed in the bid or contract.

#	LAST NAME/ENTITY/SUBCONTRACTOR	FIRST NAME	TYPE
39			
40			
41			
42			
43			
44			
45			
46			
47			
48			
49			
50			

Check this box if you need to include additional names. Please submit a separate form with complete information. Select “Supplemental” for filing type.

10. VERIFICATION

I have used all reasonable diligence in preparing this statement. I have reviewed this statement and to the best of my knowledge the information I have provided here is true and complete.

I certify under penalty of perjury under the laws of the State of California that the foregoing is true and correct.

<p>SIGNATURE OF CITY ELECTIVE OFFICER OR BOARD SECRETARY OR CLERK</p> <p>BOS Clerk of the Board</p>	<p>DATE SIGNED</p>
---	---------------------------

Bay Corridor Transmission Distribution Project (BCTD)

Budget and Finance Committee

***Ramon Abueg
Deputy Assistant General Manager –
SFPUC Power Enterprise***

April 7, 2021

OVERVIEW OF BCTD

- Build San Francisco's first electric distribution system
- Serve customers from SFPUC Hetch Hetchy Power
- Provides GHG-free energy
- Reduce reliance on PG&E
- Redirect cost of improvements on PG&E system towards building SFPUC's distribution system
- Reduce costs of connecting new services

WHAT IS BCTD?

- **B**ay **C**orridor **T**ransmission & **D**istribution
- San Francisco's own electric distribution system
 - 12,470 volts
 - Serving the east corridor
- Customers
 - Pier 70, Mission Rock, Seawall Lot 337, Pier 48, Pier 50, UCSF, Bruce Flynn Station, Southeast Community Center, Southeast Treatment Plant, Mariposa Pump Station

BCTD

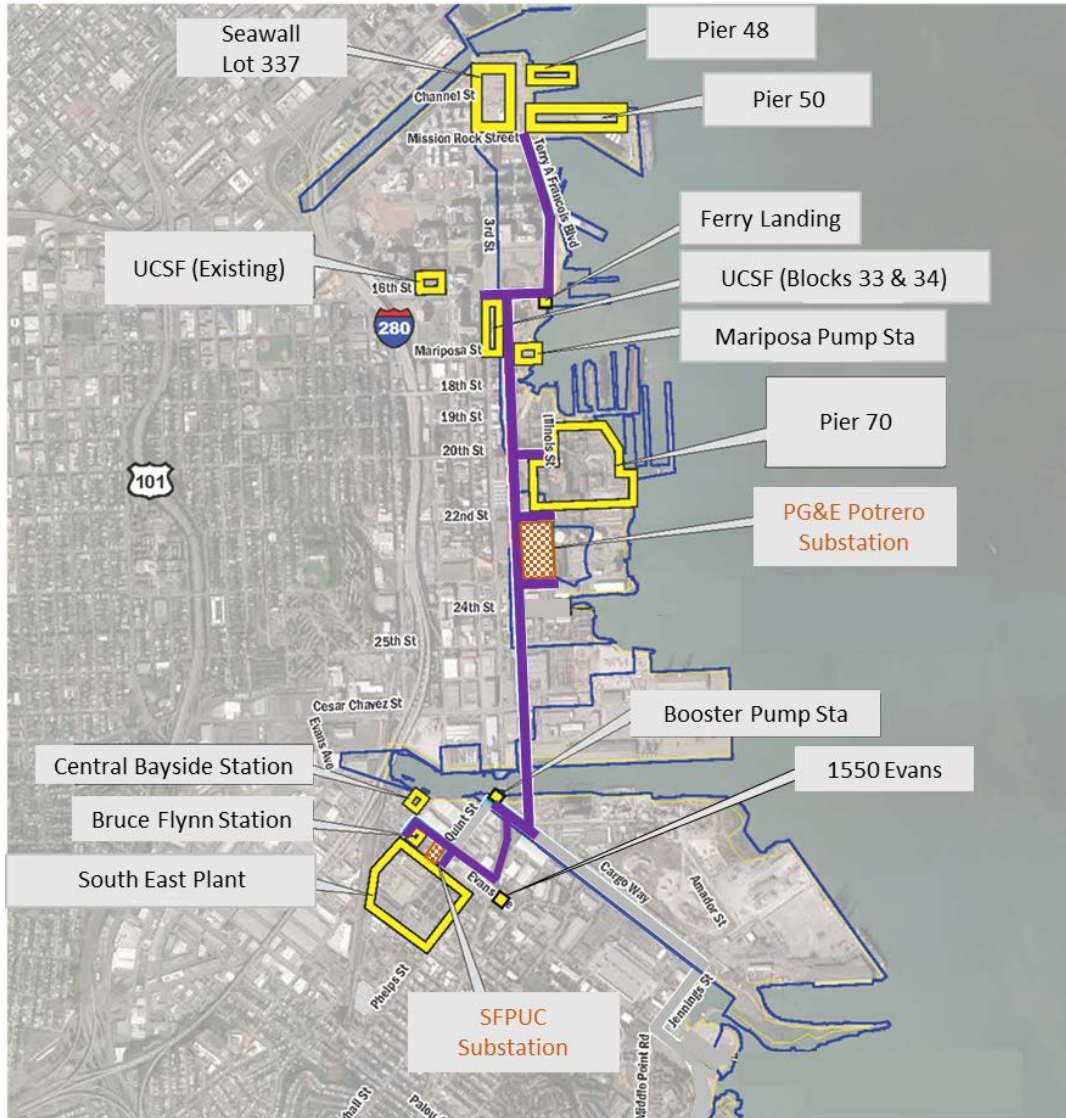

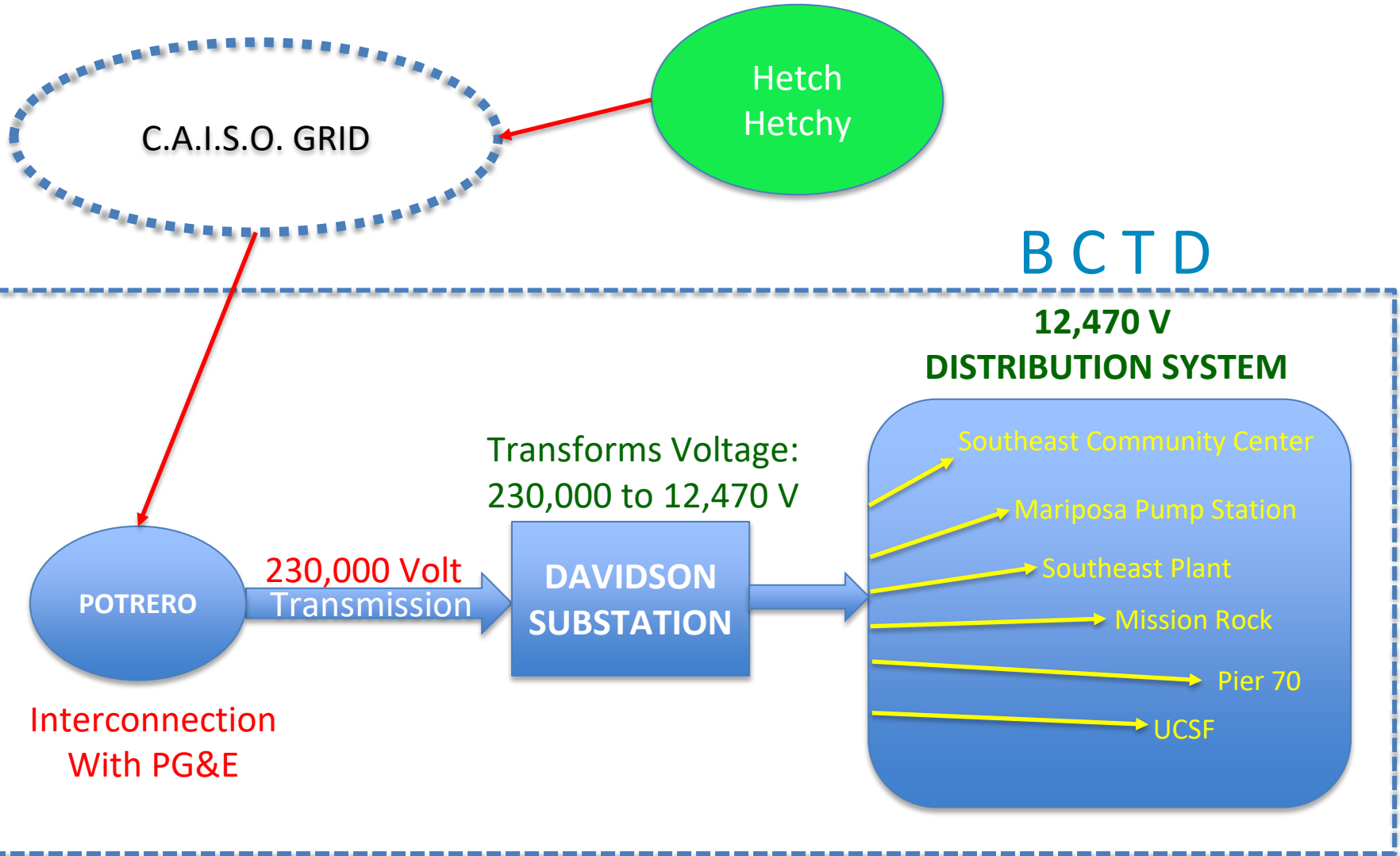



TRANSMISSION FACILITIES AGREEMENT (TFA)

- Presented for your approval today to enter into TFA
- Need to interconnect with PG&E Transmission System
- Transmission lines are owned by PG&E
- Provides access to deliver clean power from Hetch Hetchy
- No other interconnection point available

- BCTD Transmission and Distribution Substructure:
 - ~ 50 % complete
- Davidson Substation
 - ~ 10 % complete
 - Major equipment ordered
- Interconnection with PG&E:
 - Design completed
 - Major equipment ordered
 - Need TFA approved to construct substation at Potrero

Thank you