

File No. 230009

Committee Item No. 10

Board Item No. _____

COMMITTEE/BOARD OF SUPERVISORS

AGENDA PACKET CONTENTS LIST

Committee: Budget and Finance Committee Date February 1, 2023

Board of Supervisors Meeting Date _____

Cmte Board

- Motion
- Resolution
- Ordinance
- Legislative Digest
- Budget and Legislative Analyst Report
- Youth Commission Report
- Introduction Form
- Department/Agency Cover Letter and/or Report
- MOU
- Grant Information Form
- Grant Budget
- Subcontract Budget
- Contract/Agreement
- Form 126 – Ethics Commission
- Award Letter
- Application
- Public Correspondence

OTHER (Use back side if additional space is needed)

- Port Commission Resolution No. 22-53 11/4/2022
- _____
- _____
- _____
- _____
- _____
- _____
- _____
- _____
- _____

Completed by: Brent Jalipa Date January 26, 2023

Completed by: Brent Jalipa Date _____

1 [Real Property Lease - Autodesk, Inc. - Pier 9, Suite 116, and Bays 1-3 - Monthly Rent
2 \$124,508]

3 **Resolution approving Port Commission Lease L-16848 with Autodesk, Inc., a Delaware**
4 **Corporation, located at Pier 9, Suite 116, and Bays 1-3 for approximately 30,590 square**
5 **feet of office and shed space and license area for solar panels and public**
6 **improvements for a term of one year with one option to extend the term for one year,**
7 **effective upon approval of this Resolution at a monthly rent of \$124,508; and to**
8 **authorize the Executive Director of the Port to enter into any additions, amendments or**
9 **other modifications to the Lease do not materially increase the obligations or liabilities**
10 **of the City or Port and are necessary or advisable to complete the transactions which**
11 **this Resolution contemplates and effectuate the purpose and intent of this Resolution.**

12
13 WHEREAS, California Statutes of 1968, Chapter 1333 (the "Burton Act") and Charter
14 Sections 4.114 and B3.581 empower the Port Commission with the power and duty to use,
15 conduct, operate, maintain, manage, regulate and control the Port area of the City and County
16 of San Francisco; and

17 WHEREAS, Autodesk, Inc. ("Autodesk") is a tenant in good standing under its current
18 lease L-15169 located at Pier 9, Suite 116 and Bays 1-3 in the Northern Waterfront in the City
19 and County of San Francisco (the "Premises"); and

20 WHEREAS, Port Staff has negotiated the terms of a new one year lease with one
21 option to extend the term for one (1) additional year for approximately 30,590 square feet of
22 office and shed space for continued use as office, research and development, and workshop
23 space (the proposed "Lease"); and

1 WHEREAS, In November 2022, through Resolution No. 22-53, the Port Commission
2 approved the Lease with Autodesk; and

3 WHEREAS, The permitted use under the proposed Lease is a continuation of an
4 existing use, and has no potential to result in any new direct or indirect physical change to the
5 environment; approval of the proposed Lease is therefore not a project subject to review
6 under the California Environmental Quality Act (CEQA); and

7 WHEREAS, The Lease will initially generate revenues of approximately \$124,508 per
8 month, increasing to approximately \$128,212 per month if the one year option is exercised;
9 and

10 WHEREAS, The Lease is on the Port's standard form lease, provides the following key
11 terms: monthly rent equal to the current parameter rental rate of \$4.25/sf per month for a
12 portion of the Premises, \$1.75/sf per month for the remainder of the Premises and a
13 maintenance fee of \$3,000/month adopted by the Port Commission (with a three percent
14 increase in the rent for the option term); Autodesk must maintain and repair the solar panels
15 at no cost to the Port and agrees that the solar license is revocable on 30-days notice;
16 Autodesk must repair the Public Improvements (as defined in the Lease); no transfers without
17 Port's consent in its sole discretion; no holdover rights; and includes the Port's standard
18 provisions regarding as-is conditions, the Seawall project, Port participation in sale of the
19 lease, hazardous materials, indemnity, insurance, and all required City provisions; and

20 WHEREAS, San Francisco Charter, Section 9.118, requires Board of Supervisors'
21 approval of non-maritime leases under the jurisdiction of the Port Commission which either
22 have a term in excess of ten years or have anticipated revenue to the City of \$1,000,000 or
23 more; and

24 WHEREAS, The Port anticipates revenues from this Lease to exceed \$1,000,000; and
25

1 WHEREAS, The proposed rent under the Lease, along with other negotiated terms, is
2 not less than Market Rent as defined in Administrative Code, Section 23.2; and now therefore
3 be it

4 RESOLVED, That the Board of Supervisors approves the proposed Lease and
5 authorizes the Executive Director of the Port or her designee to execute such Lease in
6 substantially the same form as the Lease on file with the Clerk of the Board of Supervisors in
7 File No. 230009; and, be it

8 FURTHER RESOLVED, That the Board of Supervisors authorizes the Executive
9 Director to enter into any additions, amendments or other modifications to the Lease that the
10 Executive Director, in consultation with the City Attorney, determines, when taken as a whole,
11 to be in the best interest of the Port, do not materially increase the obligations or liabilities of
12 the City or the Port, and are necessary or advisable to complete the transactions which this
13 Resolution contemplates and effectuate the purpose and intent of this Resolution, such
14 determination to be conclusively evidenced by the execution and delivery by the Executive
15 Director of such documents; and, be it

16 FURTHER RESOLVED, That within thirty (30) days of the Lease being fully executed
17 by all parties, the Port shall provide a copy of the Lease to the Clerk of the Board for inclusion
18 into the official file.

19 n:\port\as2022\9690151\01609311.docx

<p>Item 10 File 23-0009</p>	<p>Department: Port Commission (Port)</p>
<p>EXECUTIVE SUMMARY</p>	
<p style="text-align: center;">Legislative Objectives</p> <ul style="list-style-type: none"> • The proposed resolution would retroactively approve a lease between the Port of San Francisco (Port) and Autodesk, Inc. for approximately 30,590 square feet of office and shed space at Pier 9, for a term of one year from February 2023 through January 2024, with a one-year option to extend through January 2025, and initial monthly rent of \$124,508. <p style="text-align: center;">Key Points</p> <ul style="list-style-type: none"> • Autodesk has leased space from the Port at Pier 9 since 2012. The lease comprises three parcels, totaling approximately 27,190 square feet of office space and 3,400 square feet of shed space. Autodesk’s lease expired on January 15, 2023 and is currently in holdover status. Autodesk is unsure of its long-term office needs, as the staff may telecommute, and is only willing to agree to a one-year lease with a one-year option to extend at this time. • Under the proposed lease, Autodesk would pay initial monthly rent of \$4.25 per square foot for the office space and \$1.75 per square foot for the shed space, consistent with the Port’s FY 2022-23 minimum parameter rents approved by the Port Commission in August 2022. <p style="text-align: center;">Fiscal Impact</p> <ul style="list-style-type: none"> • Over the initial one-year term of the proposed lease, the Port would receive \$1,494,090 in rent. If the one-year option to extend is exercised, the Port would receive an additional \$1,538,546 in rent, for total rent of \$3,032,636. <p style="text-align: center;">Policy Consideration</p> <ul style="list-style-type: none"> • Like the 2012 lease it is replacing, the proposed lease with Autodesk was not competitively bid. Administrative Code Section 23.33 states that leases of City-owned property with rent of at least \$2,500 per month should be awarded through a competitive solicitation unless it would be impractical or impossible. According to Port staff, a competitive solicitation in this case would be impractical due to the customization of the premises, high commercial vacancy rates in downtown San Francisco, and the desire to retain a stable tenant in good standing. As the proposed rental rates are consistent with minimum parameter rates set in the FY 2022-23 Rental Rate Schedule, the Budget and Legislative Analyst recommends approval of the proposed resolution. <p style="text-align: center;">Recommendations</p> <ul style="list-style-type: none"> • Amend the proposed resolution to state that approval is retroactive. • Approve the resolution as amended. 	

MANDATE STATEMENT

City Charter Section 9.118(c) states that (1) any lease of real property for ten or more years, including options to renew, or having anticipated revenues to the City of \$1,000,000, or (2) the modification, amendment, or termination of these leases is subject to Board of Supervisors approval.

According to City Administrative Code Section 23.33, leases of City property with rent of at least \$2,500 per month should be awarded through a competitive solicitation unless such competitive solicitation is impractical or impossible. The terms “impractical” and “impossible” are not defined in the Administrative Code. Administrative Code Section 23.33 also specifies that any leases of City-owned property awarded without a competitive solicitation shall have rent equal to fair market value or more.

BACKGROUND

Autodesk, Inc. has leased space from the Port of San Francisco (Port) at Pier 9 since 2012. The lease totals approximately 30,590 square feet across three parcels, comprised of approximately 12,064 square feet of ground floor office space and 9,266 square feet of second floor office space in Parcel A, 5,860 square feet of ground floor office space in Parcel B, and 3,400 square feet of shed space in Parcel C.

Autodesk’s lease expired on January 15, 2023 and is currently in holdover status. According to Port Management, Autodesk is unsure of its long-term office needs, as the staff may telecommute, and is only willing to agree to a one-year lease with a one-year option to extend at this time.¹ In November 2022, the Port Commission approved a new lease with Autodesk.

DETAILS OF PROPOSED LEGISLATION

The proposed resolution would approve a lease between the Port and Autodesk for approximately 30,950 square feet of office and shed space at Pier 9 for a term of one year, with a one-year option to extend, and initial monthly rent of \$124,508. The proposed resolution would also authorize the Port’s Executive Director to make immaterial amendments to the lease. As the proposed lease would commence on February 1, 2023, the Budget and Legislative Analyst recommends amending the resolution to state that approval is retroactive.

According to Don Kavanagh, Port Senior Property Manager, Autodesk’s space is highly customized and it would be difficult to find another long-term tenant for the premises in as-is condition. Autodesk is a tenant in good standing and has spent over \$9 million in improvements to the space². Autodesk would pay monthly rent of \$4.25 per square foot for the office space and \$1.75 per square foot for the shed space, consistent with the Port’s FY 2022-23 minimum parameter rents approved by the Port Commission in August 2022. Additionally, Autodesk has three other leases with the Port for office and storage spaces at Pier 9 and Pier 19, totaling

¹ In January 2023, Autodesk announced that it is placing approximately 73,000 square feet of office space at its headquarters at 1 Market Plaza for sublease.

² To partially offset these improvements, the Port has provided \$3,261,311 in rent credits (Files 12-1170, 14-0309).

approximately 11,505 square feet.³ Port Staff has negotiated new leases with Autodesk for these spaces that would be coterminous with the proposed lease.

In addition to the leased office and shed space, the proposed lease would encompass Autodesk’s Solar License and Public Access Parcel Maintenance Agreement, which have been separate documents. Autodesk has installed solar panels and equipment on approximately 6,622 square feet of roof space on Pier 9. Upon vacating the premises, Autodesk would have to remove the solar equipment or transfer ownership to the Port, if requested. Autodesk would also continue to pay the Port \$3,000 per month to clean and maintain the public wharf between Piers 9 and 15. The key terms of the proposed lease are shown in Exhibit 1 below.

Exhibit 1: Key Terms of Proposed Lease

Premises	Approximately 30,590 square feet at Pier 9 (27,190 square feet of office space and 3,400 square feet of shed space)
Term	1 Year (February 2023 through January 2024)
Options to Extend	One 1-year option
Initial Monthly Rent	\$124,508 (includes public access parcel cleaning/maintenance fee)
Rent Adjustment	3% increase during extension term
Solar License	6,622 square feet of roof space permitted for solar equipment
Public Access Parcel	\$3,000 monthly payment to Port to clean and maintain public wharf
Security Deposit	\$249,015
Maintenance and Repairs	Paid by tenant
Utilities	Paid by tenant

Source: Proposed Lease

FISCAL IMPACT

Over the initial one-year term of the proposed lease, the Port would receive \$1,494,090 in rent. If the one-year option to extend is exercised, the Port would receive an additional \$1,538,546 in rent, for total rent of \$3,032,636. Annual rent paid by Autodesk is shown in Exhibit 2 below.

Exhibit 2: Annual Rent Paid by Autodesk

Year	Office Rent	Shed Rent	Maintenance Fee	Total Rent
Year 1	\$1,386,690	\$71,400	\$36,000	\$1,494,090
Year 2 (Option)	1,429,106	73,440	36,000	1,538,546
Total	\$2,815,796	\$144,840	\$72,000	\$3,032,636

Source: Proposed Lease

³ The other three leases may be approved administratively and do not require Board of Supervisors or Port Commission approval because they do not exceed 10 years or \$1 million in total revenue.

POLICY CONSIDERATION**No Competitive Solicitation**

Like the 2012 lease it is replacing, the proposed lease with Autodesk was not competitively bid. Administrative Code Section 23.33 states that leases of City-owned property with rent of at least \$2,500 per month should be awarded through a competitive solicitation unless it would be impractical or impossible, but does not define the terms “impractical” and “impossible.” In the resolution setting the Port’s FY 2022-23 Rental Rate Schedule, the Port Commission “finds that competitively bidding the real property agreements covered by the... rental rate schedules approved by this Resolution is impractical” and therefore established uniform rates for leases or licenses for special events, office, warehouse space, or unimproved land.

According to Port staff, a competitive solicitation in this case would be impractical due to the customization of the premises, high commercial vacancy rates in downtown San Francisco, and the desire to retain a stable tenant in good standing. The Port’s Tenant in Good Standing Policy states that tenants in good standing may receive consideration for lease amendments, additional term, change in leasehold size, assignments or sublets, and/or requests for additional agreements on Port property.

Administrative Code Section 23.33 also states that leases awarded without a competitive solicitation shall have rent equal to fair market value or more. As the proposed rental rates are consistent with minimum parameter rates set in the FY 2022-23 Rental Rate Schedule, the Budget and Legislative Analyst recommends approval of the proposed resolution.

RECOMMENDATIONS

1. Amend the proposed resolution to state that approval is retroactive.
2. Approve the resolution as amended.



**CITY AND COUNTY OF SAN FRANCISCO
LONDON N. BREED, MAYOR**

LEASE NO. L-16848

BY AND BETWEEN

**THE CITY AND COUNTY OF SAN FRANCISCO
OPERATING BY AND THROUGH THE
SAN FRANCISCO PORT COMMISSION**

AND

AUTODESK, INC. A DELAWARE CORPORATION

PIER 9, SUITE 116 AND BAYS 1-3

LEASE DATE: OCTOBER 31, 2022

**ELAINE FORBES
EXECUTIVE DIRECTOR**

SAN FRANCISCO PORT COMMISSION

**WILLIE ADAMS, PRESIDENT
KIMBERLY BRANDON, VICE PRESIDENT
JOHN L. BURTON, COMMISSIONER
GAIL GILMAN, COMMISSIONER
STEVEN LEE, COMMISSIONER**

TABLE OF CONTENTS

	<u>Page</u>
1. DEMISE.....	1
2. DEFINITIONS.....	1
3. PREMISES; AS-IS CONDITION	8
3.1. Premises	8
3.2. Accessibility Inspection Disclosure.....	8
3.3. No Right to Encroach.....	9
3.4. Proximity of Development Project	9
3.5. No Light, Air or View Easement	10
3.6. Unique Nature of Premises	10
3.7. Seawall.....	10
3.8. As-Is Condition.....	10
3.9. Reserved Rights Regarding Seawall.....	11
3.10. Release and Waiver.....	11
3.11. Port's Rights Regarding Premises	11
4. TERM OF LEASE; TERMINATION BY PORT	12
4.1. Term	12
4.2. Termination Rights	12
4.3. Waiver of Relocation Benefits.....	13
5. RENT	13
5.1. Base Rent	13
5.2. Default Interest.....	13
5.3. Late Charges/Habitual Late Payer	13
5.4. Returned Checks	13
5.5. Net Lease	14
5.6. Additional Charges	14
6. TAXES AND ASSESSMENTS	14
6.1. Payment of Taxes.....	14
6.2. Possessory Interest Tax.....	15
7. SECURITY DEPOSIT.....	15

- 8. USE OF THE PREMISES 16
 - 8.1. Permitted Use..... 16
 - 8.2. Prohibited Use..... 16
 - 8.3. Notice of Prohibited Use Charge 17
- 9. COMPLIANCE WITH LAWS AND REGULATIONS 17
- 10. PORT ACTING AS OWNER OF PROPERTY; REGULATORY APPROVALS;
COMPLIANCE WITH CITY'S RISK MANAGER'S REQUIREMENTS..... 18
 - 10.1. Port Acting as Owner of Property..... 18
 - 10.2. Regulatory Approvals 18
 - 10.3. Compliance with City's Risk Manager's Requirements 18
- 11. MAINTENANCE AND REPAIRS 19
 - 11.1. Tenant Maintenance and Repair Obligations..... 19
 - 11.2. Port's Right to Inspect 19
 - 11.3. Port's Right to Repair 19
 - 11.4. Acts of Nature 20
- 12. UTILITIES AND SERVICES 20
 - 12.1. Utilities..... 20
 - 12.2. Services 21
 - 12.3. On-Site Renewable Energy 21
 - 12.4. Energy Consumption Disclosure 21
- 13. IMPROVEMENTS AND ALTERATIONS 21
 - 13.1. Port Consent Required 21
 - 13.2. Construction Requirements..... 22
 - 13.3. Improvements Part of Realty 23
 - 13.4. Removal of Improvements..... 24
 - 13.5. Removal of Non-Permitted Improvements 24
 - 13.6. All-Gender Toilet Facilities 24
 - 13.7. Signs..... 24
 - 13.8. Improvements on Roof 24
 - 13.9. Port's Alterations..... 25
- 14. LIENS 25
- 15. HAZARDOUS MATERIALS 25
 - 15.1. Requirements for Handling..... 25

15.2.	Tenant Responsibility	26
15.3.	Tenant's Environmental Condition Notification Requirements	26
15.4.	Requirement to Remediate.....	27
15.5.	Port's Right to Audit	28
15.6.	Notification of Asbestos	28
15.7.	Notification of Lead.....	28
15.8.	Storm Water Pollution Prevention	29
15.9.	Presence of Hazardous Materials.....	29
15.10.	Survival.....	29
16.	INSURANCE.....	30
16.1.	Required Insurance Coverage	30
16.2.	Claims-Made Policies	31
16.3.	Annual Aggregate Limits.....	31
16.4.	Payment of Premiums	31
16.5.	Waiver of Subrogation Rights	31
16.6.	General Insurance Matters	31
17.	DAMAGE AND DESTRUCTION.....	32
17.1.	Damage and Destruction.....	32
17.2.	Waiver.....	33
18.	EMINENT DOMAIN	33
18.1.	General.....	33
18.2.	Partial Takings	33
18.3.	Taking of the Facility.....	33
18.4.	Temporary Takings.....	33
18.5.	Award; Waiver; Termination of Lease; Rent.....	34
19.	INDEMNITY AND EXCULPATION	34
19.1.	General Indemnity	34
19.2.	Hazardous Materials Indemnity.....	34
19.3.	Scope of Indemnities.....	35
19.4.	Exculpation and Waiver.....	35
19.5.	Survival.....	35
20.	ASSIGNMENT AND SUBLETTING	36
20.1.	Transfer to Affiliate	36

20.2. Transfer to Non-Affiliate36

20.3. Sublease37

20.4. Transfer Agreement Requirements38

20.5. Notice to Port38

20.6. Transfer Audit.....38

20.7. Acknowledgement38

20.8. Transfer Definitions39

21. DEFAULT BY TENANT.....39

22. PORT'S REMEDIES40

22.1. Tenant's Right to Possession Not Terminated40

22.2. Termination of Tenant's Right to Possession.....41

22.3. Appointment of Receiver41

22.4. Port's Right to Cure Tenant's Default41

22.5. No Accord and Satisfaction42

22.6. Waiver of Redemption42

22.7. Habitual Late Payer.....42

22.8. Remedies Not Exclusive.....42

23. LITIGATION EXPENSES; ATTORNEYS' FEES42

23.1. Litigation Expenses.....42

23.2. Appeals42

23.3. City Attorney42

24. PORT'S ENTRY ON PREMISES42

24.1. Entry for Inspection42

24.2. General Entry43

24.3. Emergency Entry43

24.4. No Liability.....43

24.5. Nondisturbance43

25. SURRENDER AND QUITCLAIM.....43

25.1. Surrender.....43

25.2. Quitclaim.....44

25.3. Abandoned Property44

25.4. Survival.....44

26. HOLDING OVER44

26.1. Terms of Holdover Tenancy44

26.2. With Consent 45

26.3. Without Consent45

27. MINERAL RESERVATION.....45

28. CITY AND PORT REQUIREMENTS45

28.1. Nondiscrimination.....45

28.2. Requiring Health Benefits for Covered Employees.....46

28.3. First Source Hiring.....47

28.4. Local Business Enterprises47

28.5. Indoor Air Quality.....47

28.6. Prohibition Against Tobacco Advertising; Prohibition Against Tobacco Product Sales, Manufacture, and Distribution.....47

28.7. Prohibition of Alcoholic Beverages Advertising.....48

28.8. Graffiti Removal48

28.9. Restrictions on the Use of Pesticides48

28.10. MacBride Principles Northern Ireland.....49

28.11. Tropical Hardwood and Virgin Redwood Ban49

28.12. Preservative-Treated Wood Containing Arsenic49

28.13. Notification of Limitations on Contributions49

28.14. Sunshine Ordinance50

28.15. Conflicts of Interest.....50

28.16. Drug-Free Workplace50

28.17. Prevailing Wages and Working Conditions.....50

28.18. Local Hire51

28.19. Public Transit Information.....51

28.20. Food Service and Packaging Waste Reduction Ordinance.....51

28.21. San Francisco Bottled Water Ordinance.....51

28.22. Consideration Of Criminal History In Hiring And Employment Decisions.....52

28.23. Vending Machines; Nutritional Standards and Calorie Labeling Requirements; Offerings52

28.24. Tenant's Compliance with City Business and Tax Regulations Code53

28.25. Consideration of Salary History.....53

29. NOTICES.....53

30. MISCELLANEOUS PROVISIONS.....54

 30.1. California Law; Venue.....54

 30.2. Entire Agreement.....54

 30.3. Amendments.....54

 30.4. Severability.....54

 30.5. Interpretation of Lease.....54

 30.6. Successors.....55

 30.7. Real Estate Broker's Fees.....55

 30.8. Counterparts.....55

 30.9. Authority.....55

 30.10. No Implied Waiver.....55

 30.11. Time is of Essence.....56

 30.12. Cumulative Remedies.....56

 30.13. Survival of Indemnities.....56

 30.14. Relationship of the Parties.....56

 30.15. No Recording.....56

 30.16. Additional Written Agreement Required.....56

31. LIMITATION ON DAMAGES.....56

 31.1. No Recourse Beyond Value of Premises.....56

 31.2. Non-Liability of City Officials, Employees and Agents.....56

 31.3. Limitation on Port's Liability Upon Transfer.....56

32. TENANT ESTOPPEL CERTIFICATES.....57

33. EXTENSION OPTION.....57

 33.1. Option to Extend Term.....57

 33.2. Base Rent and Other Terms.....57

34. APPROVAL OF BOARD OF SUPERVISORS.....57

EXHIBITS AND SCHEDULES

- EXHIBIT A-1 DESCRIPTION OF PREMISES**
- EXHIBIT A-2 DESCRIPTION OF SOLAR LICENSE AREA**
- EXHIBIT A-3 DESCRIPTION OF PUBLIC ACCESS PARCEL**
- EXHIBIT A-4 PLAN AND DESCRIPTION OF PUBLIC IMPROVEMENTS**
- EXHIBIT B COMMENCEMENT DATE AND EXPIRATION DATE MEMORANDUM**
- EXHIBIT C ESTOPPEL CERTIFICATE**
- EXHIBIT D SUMMARY OF SECRETARY’S STANDARDS**
- EXHIBIT E PORT OF SAN FRANCISCO HISTORIC PRESERVATION REVIEW GUIDELINES FOR PIER AND BULKHEAD WHARF SUBSTRUCTURES**

EXHIBIT F OPERATIONS PLAN

SCHEDULE 1 ASBESTOS NOTIFICATION AND INFORMATION

SCHEDULE 2 SUBSTRUCTURE REPORT(S)

SCHEDULE 3 FEMA DISCLOSURE NOTICE

SCHEDULE 4 HAZARDOUS MATERIALS DISCLOSURE

**LEASE AGREEMENT
BASIC LEASE INFORMATION**

<i>Lease Date:</i>	October 31, 2022
<i>Lease Number:</i>	L-16848
<i>Landlord or Port:</i>	CITY AND COUNTY OF SAN FRANCISCO , a municipal corporation, operating by and through the SAN FRANCISCO PORT COMMISSION
<i>Landlord's Address:</i>	Port of San Francisco Pier 1 San Francisco, California 94111 Attention: Deputy Director, Real Estate and Development Telephone: (415) 274-0400 Facsimile: (415) 274-0494
<i>Tenant:</i>	Autodesk, Inc., a Delaware corporation
<i>Tenant's Main Contact Person and Mailing Address:</i>	Roger Van Overbeek The Landmark One Market Street, Suite 400 San Francisco, CA 94105 Telephone: (415) 507-6211 Facsimile: (415) 507-6138 Email: Roger.VanOverbeek@autodesk.com
<i>Tenant's Billing Contact and Address:</i>	Attn: Corporate Real Estate – Lease Administration The Landmark One Market Street, Suite 400 San Francisco, CA 94105 Telephone: (415) 539-4110 Email: Hazel.Sioteco@autodesk.com
<i>Tenant's Emergency Contact and Address:</i>	Albert Hoffman San Francisco Research & Technology Center at Pier 9 The Embarcadero, Suite 116 San Francisco, CA 94111 Telephone: (415) 420-1463 Email: albert.hoffman@autodesk.com

<i>Tenant's Insurance Contact and Address (not broker):</i>	Dennis Phinney Senior Risk Manager The Landmark One Market Street, Suite 400 San Francisco, CA 94105 Telephone: 415-507-6213 Email: dennis.phinney@autodesk.com
<i>Contact Information for Tenant's Agent for Service of Process (including address) :</i>	National Registered Agents Inc. 330 N. Brand Blvd., Ste 700 Glendale, CA 91203 Telephone: (800) 562-6504
<i>Premises:</i>	Suite 116 and the adjacent Bay #1, Bay #2, Bay #3 and desk space as more particularly described on Exhibit A
<i>Facility:</i>	Pier 9 San Francisco, California 94111
<i>Premises Rentable Square Footage:</i>	A total of approximately 30,590 square feet, comprised of: <u>Parcel A</u> : approximately 12,064 square feet of ground floor office space and 9,266 square feet of second floor office space as further described in <u>Exhibit A-1</u> attached hereto. <u>Parcel B</u> : approximately 5,860 square feet of ground floor office space as further described in <u>Exhibit A-1</u> attached hereto. <u>Parcel C</u> : approximately 3,400 square feet of shed space as further described in <u>Exhibit A-1</u> attached hereto.
<i>Length of Term:</i>	Twelve (12) months
<i>Commencement Date:</i>	February 1, 2023
<i>Rent Commencement Date:</i>	February 1, 2023
<i>Expiration Date:</i>	January 31, 2024
<i>Extension Option:</i>	As further described in Section 33, Tenant shall have one (1) option (the "Extension Option") to extend the term for twelve (12) months (the "Extension Term") as to all of the Premises by providing written notice to Port at least sixty (60) days' prior to the expiration date. On the first day of the Extension

	Term, the Monthly Base Rent shall be increased to the amount shown in the rent schedule below as to the Premises.			
<i>Monthly Base Rent:</i>	Months	Sq. Ft.	Monthly Base Rate	Total Monthly Base Rent
Parcel A:	1-12	21,330	\$ 4.25	\$ 90,652.50
Parcel B:		5,860	\$ 4.25	\$ 24,905.00
Parcel C:		3,400	\$ 1.75	\$ 5,950.00
Maintenance Fee for Public Improvements:				<u>\$ 3,000.00</u>
<i>Extension Option:</i>	Months	Sq. Ft.	Monthly Base Rate	Total Monthly Base Rent
Parcel A:	13-24	21,330	\$ 4.38	\$ 93,425.40
Parcel B:		5,860	\$ 4.38	\$ 25,666.80
Parcel C:		3,400	\$ 1.80	\$ 6,120.00
Maintenance agreement for public access space:				<u>\$ 3,000.00</u>
<i>Security Deposit:</i>	Two Hundred Forty-Nine Thousand Fifteen and 00/100 Dollars (\$249,015.00)			
<i>Permitted Use:</i>	<p><u>Parcels A and B:</u> Office, research and development and workshop space uses, and all related legal uses. The workshop space use shall include the placement and operation of machinery and equipment, including, without limitation, mills, lathes, drill press, circular saw, scroll saw, laser cutter, welder and the like, and maintenance, repair and replacement of such equipment.</p> <p><u>Parcel C:</u> Research and development and workshop space uses.</p> <p>All uses and activities must be conducted in compliance with the Operations Plan (as defined below).</p>			
<i>Solar License</i> <i>Solar License/Permitted Solar License Activity:</i>	Tenant, as licensee, shall have a non-exclusive, personal, non-assignable, revocable privilege to enter and use the Solar License Area for the Permitted Solar License Activity only on a temporary basis during the Solar License Term unless			

	<p>sooner terminated pursuant to the terms of this Solar License (the “Solar License”) to maintain, repair, and remove solar panels, together with related equipment, inverters, mountings and support (collectively, the “Solar Panels”), on the area of the roof of the Building shown on <i>Exhibit A-2</i> (the “Solar License Area”), in accordance with this License (the “Permitted Solar License Activity”). The Solar Panels shall generate electricity for use in Tenant’s Premises only. Tenant is prohibited from selling electricity generated by the Solar Panels.</p>
<i>Solar License Area:</i>	<p>Approx. 6,622 rentable square feet of roof space on the Facility in the City and County of San Francisco, State of California, as further described in <i>Exhibit A-2</i> attached hereto and made a part hereof, together with any and all improvements and alterations thereto.</p>
<i>Solar License Term:</i>	<p>Month to Month; either party may terminate this Solar License with thirty (30) day prior written notice.</p>
<i>Revocability:</i>	<p>Without limiting any of Port's rights hereunder, by initialing below, Tenant, as licensee, agrees and acknowledges that Port may, in its sole and absolute discretion, revoke or terminate this Solar License at any time prior to the Expiration Date, without cause and without obligation to pay any consideration to Tenant, as licensee, ("Port's Termination Right"). Failure of Tenant to initial below shall in no way affect or hinder Port's Termination Right. <u>SF</u></p> <p>Initials: _____ Tenant as licensee</p>
<i>Removal of Solar Panels:</i>	<p>Tenant shall remove the Solar Panels as required by Section 25 (Surrender) in compliance with all regulatory requirements, including obtaining Regulatory Approvals.</p>
<i>Limitations:</i>	<p>Tenant shall not install any equipment on the roof or any other part of the Facility outside of the Solar License Area or the Premises without Port's prior written consent. The Solar License granted hereby includes the right of ingress and egress through the Facility during non-business hours for access to or from the Solar License Area and the Solar Panels.</p>
<i>Port Project/Roof Repair:</i>	<p>Without limiting Port's ability to revoke this Solar License as described above, Port reserves the right to require Tenant to temporarily or permanently cease operation of the Solar Panels or to remove the Solar Panels or a portion thereof, upon thirty (30) days' prior written notice, in order for Port to conduct maintenance and repair of the roof or the structure supporting the roof or for a Port project or other activities including without limitation to expand or remove the roof or portion of the Facility. In case of emergency, Port will provide prior notice if possible.</p> <p>Port shall provide a reasonable deadline by which Tenant must shut down or remove the Solar Panels, except that in an emergency, Port may require immediate shut down or</p>

	<p>removal. If Tenant fails to shut down or remove the Solar Panels as directed by Port, Port may shut down or remove them at Tenant's sole cost and expense.</p> <p>In the event Port directs Tenant to remove the Solar Panels and Tenant complies, Port shall use reasonable efforts to find an alternative location on the roof of the Facility for Tenant to re-install the Solar Panels, at its sole cost and expense, subject to availability, condition of the roof and the supporting structure and permitting. In such case, the parties will amend this license to redefine the Solar License Area as necessary.</p>
<i>Notice and Access:</i>	<p>Tenant and its Agents shall have access to the Facility and the Solar License Area as reasonably required to maintain and repair Solar Panels and associated equipment; provided that Tenant must notify the Port's designated property manager at least 24 hours in advance of any access, obtain approval for access and comply with all reasonable requirements imposed by the Port property manager with respect to Tenant's requested access. Tenant agrees that, as a condition of its approval, Port may require Port Maintenance personnel to accompany Tenant and/or its Agents during all access. In the event of an emergency, Tenant shall have the right to enter the Facility and Solar License Area provided it makes good faith efforts to notify Port in advance of such entry.</p>
<i>Maintenance and Repair:</i>	<p>Tenant shall be responsible for all costs associated with the maintenance and repair of the Solar Panels and any related equipment.</p>
<i>Utilities and Services:</i>	<p>All utilities and services associated with the Solar Panels shall be the sole responsibility of Tenant and Port may require the utilities to be separately metered. The electricity generated by the Solar Panels shall be for the Tenant's use only and in the event the Solar Panels generate more electricity than required by the Tenant or Facility's usage then there shall be no rent credit or profiting by the Tenant for excess electricity generated.</p>
<i>Existing Condition:</i>	<p>Tenant acknowledges that Port has made no representations or warranties concerning the Solar License Area, including without limitation, the seismological condition thereof. By entering onto the Solar License Area under this Solar License, Tenant acknowledges its receipt of Schedule 1 regarding the presence of certain Hazardous Materials, and Schedule 2 regarding the condition of the substructure of the Facility and shall be deemed to have inspected the Solar License Area and accepted the Solar License Area in its "As Is" condition and as being suitable for the conduct of Tenant's activity thereon.</p>
<i>Prior License:</i>	<p>The parties agree that as of the Commencement Date, License No. 15698 dated as of August 20, 2013 (the "Prior License"), between Tenant and Port is hereby terminated; provided, however, that the parties shall continue to be liable for any obligations under the Prior License which have accrued prior to the date of termination and any obligations which by their</p>

<p><i>Lease terms applicable to License:</i></p>	<p>terms survive the termination or expiration of the Prior License.</p> <p>Except as provided herein, the rights by Solar License described above are for the same purposes and are subject to all of the terms and conditions of this Lease as if the Solar License Area is the Premises, but Tenant agrees and acknowledges that, the Solar License is non-exclusive, and non-possessory, and revocable and that Port may, in its sole and absolute discretion, upon not less than thirty (30) days' prior written notice to Tenant, revoke or terminate the Solar License at any time prior to the Expiration Date, without cause and without obligation to pay any consideration to Tenant. The parties agree that provisions regarding the nature of the Solar License are material and that the Port would not have granted the Lease absent such provisions.</p>
<p><u><i>Public Access Parcel License:</i></u></p> <p><i>Public Improvements License Area:</i></p> <p><i>Public Improvements:</i></p> <p><i>Public Improvements License/Permitted Public Improvements License Activity:</i></p> <p><i>Exhibits:</i></p>	<p>Pursuant to the Prior Lease (defined below) Tenant, among other things, was obligated to comply with all regulatory permit requirements including those imposed by the San Francisco Bay Conservation and Development Commission (“BCDC”) pursuant to BCDC Permit No. 2000.15.02 as amended (“BCDC Permit”) which includes requirements to construct various “public access” improvements on and off the Premises. Pursuant to the BCDC Permit, Tenant constructed public amenities (the “Public Improvements”) located on a public access area or “parklet” comprised of approximately 6,594 square feet on the marginal wharf located between Pier 9 and Pier 15, as shown on <i>Exhibit A-3</i> attached hereto (the “Public Access Parcel” or the “Public Improvements License Area”).</p> <p>The Public Improvements include “barnacle-themed” pre-cast concrete seating structures, approximately 150 linear feet of wharf railing along water, wooden pile interpretive elements and future temporary exhibits for public use and enjoyment to be used for gathering and seating.</p> <p>Tenant, as licensee, shall have a non-exclusive, personal, non-assignable, revocable privilege to enter and use the Public Access Parcel for the Permitted Public Improvements License Activity only on a temporary basis during the Public Improvements License Term unless sooner terminated pursuant to the terms of this Public Improvements License (the “Public Improvements License”) to maintain, repair, and remove the Public Improvements on the Public Access Parcel in accordance with this Public Improvements License (the “Permitted Public Improvements License Activity”).</p> <p>In addition the foregoing, from time to time during the Public Access Parcel License Term, Tenant, as licensee, shall</p>

	<p>activate temporary exhibits in the Exhibit Space in the area shown on Exhibit A-4 after good faith collaboration with the Exploratorium on the design and scope thereof. Tenant acknowledges that any exhibit that is the result of such collaboration shall be submitted to Port for its review under the Design Review protocol described below. The collaboration with the Exploratorium may include, pursuant to a separate agreement between Tenant and the Exploratorium, the construction by Exploratorium of one or more temporary exhibits. Tenant shall demonstrate its collaboration efforts to the Port through documented meetings, correspondence and plans. To the extent that the Exploratorium and Tenant are unable to agree on the design and/or scope of an exhibit, Tenant shall notify the Port in writing what the basis of disagreement is and the steps taken to address the impasse. The Port shall then request that Tenant and Exploratorium meet with Port to determine if Tenant and the Exploratorium can resolve the dispute.</p> <p>Tenant shall bear all costs of any kind or nature in connection with it's the Public Improvements License, and keep the Public Access Parcel free and clear of any liens or claims of lien arising out of or in any way connected with the Public Improvement License.</p>
<p><i>Design Review Protocol:</i></p>	<p>Tenant shall design the temporary exhibits in the Exhibit Space subject to Port's and, at Port's election, the Waterfront Design Advisory Committee's, written approval of the design, size, color, position and method of attachment or installation of such temporary exhibits as described in Exhibit A-4. All temporary exhibits shall be designed so as to prevent any unreasonable interference with general pedestrian use of the area, comply with the Americans with Disabilities Act (42 U.S.C. §§ 12101 et seq) and minimize any potential tripping or other hazards.</p>
<p><i>Port's Routine Maintenance of Public Improvements:</i></p>	<p>Port will provide routine cleaning and general maintenance services for the Public Access Parcel and Public Improvements ("Port's Routine Maintenance"). As part of Port's Routine Maintenance, Port will undertake the following on a daily, weekly or monthly basis, as determined by Port in its sole discretion: (i) maintaining the Public Access Parcel and Public Improvements in a neat and orderly fashion, including cleaning surfaces, (ii) repairs to the deck surface, (iii) removing posts and graffiti, (iv) controlling and removing litter, (v) observing and reporting to Tenant safety hazards and repair needs, and (vi) providing and emptying trash receptacles. Port is not responsible for other services, utility systems or maintenance and repair of the marginal wharf or improvements or alterations thereon. Port's Routine Maintenance shall include visual inspection of the Public Improvements as Port deems necessary in its sole discretion, but such inspection shall not relieve Tenant of its Tenant Public Improvement Obligations, nor shall Port's failure to inspect alter the parties' respective obligations. Port shall not</p>

<p><i>Additional Rent/Maintenance Fee:</i></p>	<p>be obligated to make any repairs, replacement or renewals of any kind, nature or description whatsoever to the Public Improvements, the Public Access Parcel or to any improvements or alterations now or hereafter located thereon.</p> <p>Tenant shall reimburse Port for its actual costs (including labor, time and materials) for Port's Routine Maintenance incurred during the Public Access Parcel License Term within thirty (30) days of Port's invoice. The cost of Port's Routine Maintenance is estimated to be \$3,000 per month, subject to change from time to time to reflect the actual costs incurred by the Port. Such amounts shall be Additional Rent under the Lease. At Tenant's request, but not more than twice during any calendar year, Port shall provide Tenant with reasonable documentation of the cost of Port's Routine Maintenance.</p>
<p><i>Repairs:</i></p>	<p>Tenant will provide all repairs to the Public Improvements, including repairs and replacement of seating elements and other components thereof, to preserve the Public Improvements in a first class condition. When Port determines that repairs resulting from damage from any cause, including, without limitation, acts of vandalism, weather, casualty and wear and tear are needed, at the Port's sole discretion, on a case-by-case basis, Port will so advise Tenant, and Port can elect in writing to either (i) make the necessary repairs at Tenant's cost or (ii) require Tenant to make such repairs. If Port requires Tenant to complete the repairs, Tenant must contract with qualified parties to carry out the repairs in a professional manner, and complete the repairs in a timely manner at its sole cost. In the case of an emergency that impacts public safety or causes the Public Improvements or a portion thereof to be closed, Port may require repairs to be completed within forty-eight (48) hours. If Port performs the repairs, Tenant shall reimburse Port for its actual costs within thirty (30) days of Port's invoice and the amounts due shall be Additional Rent under this Lease.</p>
<p><i>Replacement of Public Improvements:</i></p>	<p>In the event that Tenant or its Agents or Invitees cause any damage to the Public Access Parcel or any other Port property, Tenant shall be responsible and Port may, at its sole and absolute discretion, elect to repair the same itself or require Tenant to repair the same, all at Tenant's sole cost and expense. Not later than ten (10) business days after receipt of any invoice from Port for costs incurred by Port related to any repair performed by Port in accordance with this provision, Tenant shall reimburse Port therefor. This provision shall survive the expiration or earlier termination of this Lease.</p> <p>Port will not require Tenant to replace the Public Improvements unless all or any portion of the Public Improvements are damaged so badly, as determined by Port and Tenant acting reasonably, that repairs cannot effectively be made. Except as provided in the preceding sentence or by BCDC, Tenant has no obligation to replace the Public Improvements for any other reason, regardless of whether</p>

<p><i>Removal of Public Improvements:</i></p>	<p>replacement is necessitated due to destruction, ordinary wear and tear or obsolescence.</p> <p>At Port's election, and at no cost to Port, Tenant shall remove the Public Improvements upon the expiration or earlier termination of the Lease or leave them in place. If Port directs Tenant to remove the Public Improvements, Tenant shall do so in a timely manner subject to all necessary Regulatory Approvals.</p>
<p><i>Duties Upon Termination and Expiration:</i></p>	<p>On or before the last day prior to the termination or expiration of the Lease, Port and Tenant shall inspect the Public Improvements and Public Access Parcel and report in writing all maintenance and repair work necessary to put the Public Improvements and Public Access Parcel in first class condition and in a proper state of repair. Upon issuance of such report, Port may cause such maintenance and repair work to be performed with the cost thereof to be promptly paid by Tenant, as licensee. If Port elects to retain the Public Improvements, Tenant shall deliver to Port the originals of all books, permits, plans, records, licenses, contracts, and other documents pertaining to the Public Improvements, documents evidencing title or rights of Tenant, and any and all other records or documents requested by Port. Tenant further agrees to do all other things reasonably necessary to cause an orderly transition of the management and operation of the Public Improvements without detriment to the rights of Port or to the continued management of the Public Improvements. The provisions of this section shall survive the expiration or termination of this Lease.</p>
<p><i>Substructure:</i></p>	<p>Notwithstanding any other provision of this Public Improvements License, neither Port nor Tenant shall have any responsibility for the substructure of the Public Access Parcel. "Substructure" means that portion of the marginal wharf that includes all the load bearing structural elements that are at or below the top surface of the pier deck. The load bearing structural elements of the substructure include but are not limited to slab/deck, beams, piles and pile caps. "Substructure" does not include the asphalt, wood or concrete covering the wharf or any utilities located within or under the Substructure.</p>
<p><i>Existing Condition:</i></p>	<p>Tenant acknowledges that Port has made no representations or warranties concerning the Public Access Parcel, including without limitation, the seismological condition thereof. By entering onto the Public Access Area under this Public Improvements License, Tenant accepted the Public Access Area in its "As Is" condition and as being suitable for the conduct of Tenant's activity thereon.</p>
<p><i>Access:</i></p>	<p>Tenant and its Subcontractors shall have access to the Public Access Parcel at reasonable times and with prior written notice to Port to carry out the Tenant Public Improvement Obligations in this Agreement.</p>

<p><i>Subcontractors:</i></p> <p><i>Use of Public Access Parcel:</i></p> <p><i>Public Improvements License Term:</i></p> <p><i>Prior Management Agreement:</i></p> <p><i>Lease terms applicable to Public Improvements License:</i></p>	<p>Tenant is authorized to enter into contracts to obtain the services, materials, and other incidentals necessary to carrying out its responsibilities set forth in the Scope of Services. Tenant will engage only qualified professional contractors and consultants that to carry out the Scope of Services (collectively, "Subcontractors"). All Subcontractors are subject to the terms of this Lease. Tenant is fully responsible for the performance and for the quality of the products and services provided to Port by Tenant and its Subcontractors. Tenant will be solely responsible for the timely and prompt payment of its employees and Subcontractors</p> <p>Use of the Public Access Parcel shall be subject to the BCDC Permit, the Port Code and any rules and regulations promulgated by Port from time to time. Tenant may, but shall not be obligated to, recommend, and Port may adopt, rules and regulations governing the safe use of the Public Access Parcel from time to time.</p> <p>Month to Month; either party may terminate this Public Improvements License with thirty (30) day prior written notice.</p> <p>The parties agree that as of the Commencement Date, the Management Agreement for Public Access Space at Pier 9-15 dated as of July 8, 2014 (the "Management Agreement"), between Tenant and Port is hereby terminated; provided, however, that the parties shall continue to be liable for any obligations under the Management Agreement which have accrued prior to the date of termination and any obligations which by their terms survive the termination or expiration of the Management Agreement.</p> <p>Except as provided herein, the rights and obligations described above are for the same purposes and are subject to all of the terms and conditions of this Lease as if the Public Access Parcel is the Premises, and the Public Improvements are Tenant's Property, but Tenant agrees and acknowledges that Port may, in its sole and absolute discretion, upon not less than thirty (30) days' prior written notice to Tenant, revoke or terminate the Public Improvements License at any time prior to the Expiration Date, without cause and without obligation to pay any consideration to Tenant. The parties agree that provisions regarding the nature of the Public Improvements License are material and that the Port would not have granted the Lease absent such provisions.</p>
<p><i>Operations Plan:</i></p>	<p>Tenant shall adhere to the Operations Plan as approved by the Port and attached as Exhibit F. Any modifications to the Operations Plan are subject to Port approval, in its sole discretion.</p>

<i>Substructure:</i>	See Schedule 2 attached hereto.
<i>Maintenance and Repair:</i>	Tenant's sole responsibility, as further described in Section 11 below
<i>Utilities:</i>	Tenant's sole responsibility, as further described in Section 12 below
<i>Location of Asbestos in Facility:</i>	See Schedule 1 attached hereto.
<i>Hazardous Materials Disclosure:</i>	See Schedule 4 attached hereto
<i>Development Project:</i>	<ul style="list-style-type: none"> • Seawall Improvement Project • MTA Embarcadero Enhancement Program.
<i>Prior Lease:</i>	The parties agree that as of the Commencement Date, Lease No. L-15169 dated as of September 12, 2012, as amended by that certain First Amendment dated October 10, 2012, Second Amendment dated October 10, 2012, and Third Amendment dated March 26, 2014 (as amended, the " Prior Lease "), between Autodesk, Inc. and Port is hereby terminated; provided, however, that the parties shall continue to be liable for any obligations under the Prior Lease which have accrued prior to the date of termination and any obligations which by their terms survive the termination or expiration of the Prior Lease.
<i>Cross Defaults:</i>	<ul style="list-style-type: none"> • Lease L-16612 dated May 29, 2020, as amended by that First Amendment to Lease dated October 3, 2022 • Lease L-16611 dated as of May 29, 2020, as amended by that First Amendment to Lease dated October 3, 2022 • Lease L-16711 dated as of January 21, 2021, as amended by that First Amendment to Lease dated October 3, 2022.
<i>Parking:</i>	Tenant acknowledges that this Lease does not include parking rights or spaces
<i>Lease Prepared By:</i>	Vicky Lee, Leasing Manager

LEASE AGREEMENT

This Lease Agreement, dated for reference purposes only as of the Lease Date set forth in the Basic Lease Information, is by and between the **CITY AND COUNTY OF SAN FRANCISCO**, a municipal corporation ("**City**"), operating by and through the **SAN FRANCISCO PORT COMMISSION** ("**Port**"), as landlord, and the Tenant identified in the Basic Lease Information ("**Tenant**"). The basic lease information (the "**Basic Lease Information**"), the exhibits, schedule and this Lease Agreement are and shall be construed as a single instrument and are referred to herein as this "**Lease**". In the event of any conflict or inconsistency between the Basic Lease Information and this Lease Agreement, the Basic Lease Information will control.

1. DEMISE.

In consideration for the rents and all other charges and payments payable by Tenant, and for the agreements, terms and conditions to be performed by Tenant in this Lease, Port does hereby lease to Tenant, and Tenant does hereby hire and take from Port, the Premises upon the agreements, terms and conditions of this Lease for the Term hereinafter stated.

2. DEFINITIONS.

Definitions used in this Lease are found in the specified locations in this Lease or are set forth below. Definitions that are not capitalized below are not capitalized when used in this Lease.

"**ACMs**" is defined in Section 15.6 below.

"**ADA**" means the Americans with Disabilities Act, a federal law codified at 42 U.S.C. §§ 12101 et seq., including, but not limited to, Title III thereof, and all regulations and guidelines related thereto, together with any and all laws, rules, regulations, ordinances, codes and statutes now or hereafter enacted by local or state agencies having jurisdiction thereof, including all requirements of Title 24 of the State of California, as the same may be in effect on the date of this Lease and may be hereafter modified, amended or supplemented.

"**Additional Rent**" means all taxes, assessments, insurance premiums, operating and maintenance charges, fees, costs, expenses, liabilities and obligations of every description which Tenant assumes or is obligated to pay or discharge pursuant to this Lease, together with every fine, penalty, interest or other charge which may be added for non-payment or late payment, whether payable to Port or to other persons, parties or entities designated herein.

"**Affiliate**" means: (i) a Person that Controls or is Controlled by Tenant, or is Controlled by the same Person that Controls Tenant; or (ii) if Tenant is a natural Person, any designated successor by trust, will, or court order following Tenant's death or incapacity.

"**Agents**" when used with reference to either party to this Lease or any other person means the officers, directors, employees, agents, commissioners, and contractors of the party or other person, and their respective heirs, legal representatives, successors, and assigns.

"**Alterations**" means any alterations, installations, improvements, or additions to any Improvements or to the Premises.

"**Anniversary Date**" means the first and each subsequent anniversary of the Commencement Date; provided, however, that if the Commencement Date is not the first day of a month, then each Anniversary Date shall be calculated from the first day of the thirteenth (13th) month after the Commencement Date.

"**Assignment**" means a proposed or actual Transfer of Tenant's rights, title, and interest in all or any part of the Premises under a contractual assignment or an assignment by operation of Law.

"**Award**" means all compensation, sums or anything of value paid, awarded or received for a Taking, whether pursuant to judgment, agreement, settlement or otherwise.

"**Base Rent**" means the monthly Base Rent specified in the Basic Lease Information and described further in Section 5.1 hereof.

"**BCDC**" means the San Francisco Bay Conservation and Development Commission.

"**Books and Records**" means all of Tenant's books, records, and accounting reports or statements relating to its business, this Lease, and the operation and maintenance of the Premises, including cash journals, rent rolls, general ledgers, income statements, bank statements, income tax schedules relating to the Premises and any other bookkeeping documents used in Tenant's business operations for the Premises, whether maintained by Tenant or a third-party contractor.

"**business day**" means any week day during which businesses are generally open for business, excluding local, state, and federal holidays observed by Port.

"**CMD**" means the Contract Monitoring Division of the City's General Services Agency.

"**Cal-OSHA**" means the Division of Occupational Safety and Health of the California Department of Industrial Relations.

"**Changes**" is defined in Section 10.2 below.

"**City**" means the City and County of San Francisco, a municipal corporation.

"**Claims**" means all liabilities, injuries, losses, costs, claims, demands, rights, causes of action, judgments, settlements, damages, liens, fines, penalties and expenses, including without limitation, direct and vicarious liability of any kind for money damages, compensation, penalties, liens, fines, interest, attorneys' fees, costs, equitable relief, mandamus relief, specific performance, or any other relief.

"**Commencement Date**" means the date on which the Term commences as specified in the Basic Lease Information.

"**Commission**" means the San Francisco Port Commission.

"**Common Areas**" means all areas outside of the Premises and within the boundaries of the Facility that are not now or hereafter exclusively leased or exclusively permitted to other tenants or permittees, and that are designated by Port from time to time for the general common use or convenience of Port, Tenant, or other tenants of Port, and the respective authorized Agents and Invitees of the same. The Common Areas include, without limitation, driveways, delivery areas, pedestrian walkways, service corridors accessing loading docks, utility rooms, and other areas or improvements provided or designated by Port for common use. The Common Areas shall not include any parking areas located outside the boundaries of the Facility.

"**Concession**" is defined in Section 30.16 below.

"**Conduct Code**" is defined in Section 28.13 below.

"**Control**" means the direct or indirect ownership of: (a) fifty percent (50%) or more of each class of equity interests in the entity; or (b) fifty percent (50%) or more of each class of interests that have the right to nominate, vote for, or otherwise select the members of the governing body that directs or causes the direction of substantially all of the management and policies of the entity or otherwise has the right to direct or cause the direction of substantially all of the management and policies of the entity.

"**Core Benefits**" is defined in Section 28.1(c) below.

"**CPA**" means an independent certified public accounting firm acceptable to Port in its reasonable discretion.

"Date of Taking" means the earlier of (i) the date upon which title to the portion of the Property taken passes to and vests in the condemnor or (ii) the date on which Tenant is dispossessed.

"disturbed or removed" is defined in Section 13.2(g) below.

"Encroachment Area" is defined in Section 3.3 below.

"Encroachment Area Charge" is defined in Section 3.3 below.

"Environmental Laws" means any Laws relating to Hazardous Material (including its Handling, Release, or Remediation) or to human health and safety, industrial hygiene, or environmental conditions in the environment, including structures, soil, air, bay water, and groundwater, and any environmental mitigation measure adopted under Environmental Laws affecting any portion of the Facility.

"Environmental Regulatory Action" when used with respect to Hazardous Materials means any inquiry, investigation, enforcement, Remediation, agreement, order, consent decree, compromise, or other action that is threatened, instituted, filed, or completed by an Environmental Regulatory Agency in relation to a Release of Hazardous Materials, including both administrative and judicial proceedings.

"Environmental Regulatory Agency" means the United States Environmental Protection Agency, OSHA, any California Environmental Protection Agency board, department, or office, including the Department of Toxic Substances Control and the San Francisco Bay Regional Water Quality Control Board, Cal-OSHA, the Bay Area Air Quality Management District, the San Francisco Department of Public Health, the San Francisco Fire Department, the San Francisco Public Utilities Commission, Port, or any other Regulatory Agency now or later authorized to regulate Hazardous Materials.

"Environmental Regulatory Approval" means any approval, license, registration, permit, or other authorization required or issued by any Environmental Regulatory Agency, including any hazardous waste generator identification numbers relating to operations on the Premises and any closure permit.

"Exacerbate" or **"Exacerbating"** when used with respect to Hazardous Materials means any act or omission that increases the quantity or concentration of Hazardous Materials in the affected area, causes the increased migration of a plume of Hazardous Materials in soil, groundwater, or bay water, causes a Release of Hazardous Materials that had been contained until the act or omission, or otherwise requires Investigation or Remediation that would not have been required but for the act or omission. Exacerbate also includes the disturbance, removal or generation of Hazardous Materials in the course of Tenant's operations, Investigations, maintenance, repair, Improvements and Alterations under this Lease. **"Exacerbation"** has a correlating meaning.

"Excess Rent" means Sublease rent and any other sums paid or payable to Tenant under a Sublease, excluding the value of goodwill, in excess of Tenant's concurrent Rent obligation for the Sublease premises.

"Expiration Date" means the date on which the Term expires as specified in the Basic Lease Information.

"Event of Default" is defined in Section 21 below.

"Facility" means the pier, building or other structure in or on which the Premises is located.

"Facility Systems" means the plumbing, electrical, fire protection, life safety, security and other mechanical, electrical, and communications systems of the Facility.

"**financial statements**" mean a current balance sheet and profit and loss statements that have been reviewed or examined by a CPA.

"**Habitual Late Payer**" means Tenant has received (a) at least two (2) notices of monetary default, or (b) at least three (3) notices of default within a twelve (12) month period.

"**Handle**" or "**Handling**" means to use, generate, process, manufacture, produce, package, treat, transport, store, emit, discharge, or dispose of a Hazardous Material.

"**Hard costs**" is defined in Section 11.3 below.

"**Hazardous Material**" means any substance, waste, or material that is now or in the future designated by any Regulatory Agency to be capable of posing a present or potential risk of injury to human health or safety, the environment, or property. This definition includes anything designated or defined in any Environmental Law as hazardous, hazardous substance, hazardous waste, toxic, pollutant, or contaminant; any asbestos, ACMs, and PACMs, whether or not part of the structure of any existing Improvements on the Premises, any Improvements to be constructed on the Premises by or on behalf of Tenant, or occurring in nature; and other naturally-occurring substances such as petroleum, including crude oil or any fraction, and natural gas or natural gas liquids.

"**Hazardous Material Claim**" means any Environmental Regulatory Action or any Claim made or threatened by any third party against the Indemnified Parties, or the Premises or the Facility, relating to damage, contribution, cost recovery compensation, loss or injury resulting from the presence or Release of any Hazardous Materials, including, without limitation, losses based in common law. Hazardous Material Claims include, without limitation, Investigation and Remediation costs, fines, natural resource damages, damages for decrease in value of the Premises, any other part of the Facility, or other Port property, the loss or restriction of the use or any amenity of the Premises, any other part of the Facility, or other Port property, and attorneys' fees and consultants' fees and experts' fees and costs.

"**Hazardous Material Condition**" means the presence, Release, or threatened Release of Hazardous Materials in, on, or about the Premises, the Facility, other Port property, or the environment, or from any vehicles or vessels Tenant, or its Agents and Invitees uses during Tenant's occupancy of the Premises.

"**HEPA**" is defined in Section 13.2(g) below.

"**HRER**" is defined in Section 13.2(e) below.

"**Improvements**" means any and all buildings, structures, fixtures or other improvements constructed or installed on the Premises or any other part of the Facility, including those constructed by or on behalf of Tenant pursuant to this Lease (including, without limitation, any trailers, signs, roads, trails, driveways, parking areas, curbs, walks, fences, walls, stairs, poles, plantings and landscaping).

"**Improvement Costs**" is defined in Section 4.2 below.

"**Improvements Pertaining to the Realty**" means machinery or equipment installed for use on the property that cannot be removed without a substantial economic loss or without substantial damage to the property on which it is installed, regardless of the method of installation. In determining whether particular property can be removed "without a substantial economic loss," the value of the machinery or equipment in place and considered as part of the realty should be compared with its value if it were removed and sold.

"**Indemnified Parties**" is defined in Section 19.1 below.

"**Indemnify**" means to indemnify, protect, defend, and hold harmless forever. "**Indemnification**" and "**Indemnity**" have correlating meanings.

"**Interest Rate**" means ten percent (10%) per year or, if a higher rate is legally permissible, the highest rate an individual is permitted to charge under Law.

"**Investigate**" or "**Investigation**" when used with reference to Hazardous Materials means any activity undertaken to determine and characterize the nature and extent of Hazardous Materials that have been, are being, or are threatened to be Released in, on, under or about the Premises, any other part of the Facility, other Port property, or the environment, and includes, without limitation, preparation and publication of site history, sampling, and monitoring reports, performing equipment and facility testing such as testing the integrity of secondary containment and above and underground tanks, and sampling and analysis of environmental conditions before, during, and after Remediation begins and continuing until the appropriate Environmental Regulatory Agency has issued a no further action letter, lifted a clean-up order, or taken similar action.

"**Invitees**" means Tenant's clients, customers, invitees, patrons, guests, members, licensees, permittees, concessionaires, assignees, subtenants, and any other person whose rights arise through them, except that for the purposes of Article 20 (Assignment and Subletting), "**Invitees**" excludes Tenant's licensees, assignees, subtenants, and any other person whose rights arise through them.

"**Late Charge**" means a fee of fifty dollars (\$50.00).

"**Law**" means any present or future law, statute, ordinance, code, resolution, rule, regulation, judicial decision, requirement, proclamation, order, decree, policy (including the Waterfront Land Use Plan), and Regulatory Approval of any Regulatory Agency with jurisdiction over any portion of the Premises, including Regulatory Approvals issued to Port which require Tenant's compliance, and any and all recorded and legally valid covenants, conditions, and restrictions affecting any portion of the Facility, whether in effect when this Lease is executed or at any later time and whether or not within the present contemplation of the parties, as amended from time to time.

"**Lease**" is defined in the preamble to this Lease.

"**Non-Affiliate**" means a Person that is not an Affiliate.

"**Notice of Removal**" is defined in Section 13.4 below.

"**Notice to Cease Prohibited Use**" is defined in Section 8.3 below.

"**Notice to Vacate**" is defined in Section 3.3 below..

"**Official Records**" means the official records of the City and County of San Francisco.

"**OSHA**" means the United States Occupational Safety and Health Administration.

"**PACMs**" is defined in Section 15.6 below.

"**Person**" means any natural person, corporation, limited liability entity, partnership, joint venture, or governmental or other political subdivision or agency.

"**Port**" means the San Francisco Port Commission.

"**Port Guidelines**" as defined in Section 13.2(e).

"**Port program or project**" means (a) any development, removal or renovation, by public and/or private parties, of the building, pier or seawall lot in, on or in the vicinity of the Premises (including, but not limited to any Development Project described in the Basic Lease Information), or (b) with respect to any areas owned by Port or under Port's jurisdiction between and including Piers 80-96, maritime uses (by way of example only and not as a limitation, cargo shipping, fishing, passenger cruises, ship repair, ferries and excursion boats, historic ships and recreational boating), or (c) the Seawall Earthquake Safety Program.

"**Port representative**" means Port, a City auditor, or any auditor or representative designated by Port.

"**Port Work**" is defined in Section 13.9 below.

"**Premises**" means the real property described in Section 3.1 below and depicted on *Exhibit A*.

"**preservative-treated wood containing arsenic**" is defined in Section 28.12 below.

"**Prevailing party**" is defined in Section 23.1 below.

"**Prohibited Use(s)**" is defined in Section 8.2 below.

"**Regulatory Agency**" means the municipal, county, regional, state, or federal government and their bureaus, agencies, departments, divisions, courts, commissions, boards, officers, commissioners, or other officials, including BCDC, any Environmental Regulatory Agency, Port (in its regulatory capacity), other departments, offices, and commissions of the City and County of San Francisco (each in its regulatory capacity), Port's Chief Harbor Engineer, the Dredged Material Management Office, the State Lands Commission, the Army Corps of Engineers, the United States Department of Labor, the United States Department of Transportation, or any other governmental agency now or later having jurisdiction over Port property.

"**Regulatory Approval**" means any authorization, approval, license, registration, or permit required or issued by any Regulatory Agency.

"**Release**" when used with respect to Hazardous Materials means any actual or imminent spilling, introduction, leaking, pumping, pouring, emitting, emptying, discharging, injecting, escaping, leaching, dumping, or disposing in, on, under or about the Premises, any other part of the Facility, other Port property, or the environment.

"**Remediate**" or "**Remediation**" when used with respect to Hazardous Materials means to clean up, abate, contain, treat, stabilize, monitor, remediate, remedy, remove, or otherwise control Hazardous Materials, or to restore the affected area to the standard required by the applicable Environmental Regulatory Agency in accordance with applicable Environmental Laws and any additional Port requirements. "**Remediation**" also includes the creation of a remedial work plan to be approved by the appropriate Environmental Regulatory Agency when required.

"**Renewable Energy System**" is defined in Section 12.5 below.

"**Rent**" means the Base Rent, Additional Rent and all other sums payable by Tenant to Port hereunder, including, without limitation, any Late Charge and any interest assessed pursuant to Section 5.

"**Rent Commencement Date**" means the date on which the payment of Rent commences as specified in the Basic Lease Information.

"**Repair Period**" means two hundred ten (210) days after the date of damage to the Premises or the Facility by fire or other casualty.

"**Rules and Regulations**" means the Rules and Regulations, if any, applicable to the Facility as may be amended from time to time.

"**saltwater immersion**" is defined in Section 28.12 below.

"**Seawall**" is defined in Section 3.7.

"**Secretary's Standards**" is defined in Section 13.2(d) below.

"**Security Deposit**" means the amount specified in the Basic Lease Information and as further described in Section 7 below.

"**Sublease**" means a proposed or actual Transfer of all or any part of the Premises under a sublease or a sub-sublease.

"**Subletting Expenses**" means verifiable and reasonable brokerage commissions incurred in connection with a Sublease and the costs of any new tenant improvements for which Tenant is responsible under the Sublease.

"**SWPPP**" is defined in Section 15.8(a) below.

"**Taking**" means a taking or damaging, including severance damage, by eminent domain, inverse condemnation or for any public or quasi-public use under Law. A Taking may occur pursuant to the recording of a final order of condemnation, or by voluntary sale or conveyance in lieu of condemnation or in settlement of a condemnation action.

"**Tenant**" means the party identified as Tenant in the Basic Lease Information.

"**Tenant's Property**" means all furniture, trade fixtures, office equipment, and articles of movable personal property installed in the Premises by or for the account of Tenant, including, but not limited to, the Solar Panels and the Public Improvements, and any Improvements or Alterations constructed on or affixed to the Premises if designated under this Lease as Tenant's Property, in either case without cost to Port.

"**Term**" is defined in Section 4.1 below.

"**trade fixtures**" means those items of personalty, furniture, equipment, machinery used in trade by Tenant which are customarily removed without damage to the Premises at the end of a lease term in the ordinary course of businesses of the type operated by Tenant at the Premises.

"**Transfer**" means any of the following events or proposed events, whether voluntary, involuntary, or by operation of Law: (a) any sale, assignment, encumbrance, sublease, or other transfer of any of Tenant's interest in this Lease or in the Premises; (b) any Person other than Tenant occupies or claims a right of possession to any part of the Premises; (c) if Tenant is a corporation, limited liability company, partnership or similar entity and is not traded on a nationally recognized security exchange, any change in Control of Tenant (including without limitation a dissolution, merger, consolidation, transfer or sale); or (d) any interest of any subtenant, assignee, or other Transferee of Tenant's interest in the Lease or premises is sold, assigned, encumbered, or otherwise Transferred.

"**Transfer Agreement**" means all document(s) effecting or evidencing Tenant's proposed sale, assignment, encumbrance, sublease, or other Transfer.

"**Transfer Date**" means the effective date of a Transfer.

"**Transfer Notice**" means Tenant's prior written notice to Port of an intent to Transfer to a Non-Affiliate, specifying: (a) the Transferee's name, address, other contact information, and, if the Transferee is not a natural Person, its form of organization and the identity of each Person with Control of the Transferee; (b) the proposed Transfer Date and a full description of the Transfer Terms; (c) a description of the Transferee's proposed use of the Premises, including any required or desired Alterations or Improvements to the Premises that the Transferee may undertake in order to facilitate its proposed use; and (d) a list of the Transferee's personal, business, and credit references.

"**Transfer Terms**" means the terms and conditions in the proposed or final Transfer Agreement, as appropriate in context.

"**Transferee**" means the Person to which Tenant makes or proposes to make a Transfer.

"**Utilities**" means electricity, water, gas, heat, sewers, oil, telecommunication services and all other Utilities.

"**Waiving Party**" is defined in Section 16.5 below.

"Work" when used in reference to construction is defined in Section 13.2(c) below.

"worth at the time of award" is defined in Section 22.2 below.

3. PREMISES; AS-IS CONDITION.

3.1. Premises.

(a) Subject to the provisions of this Lease, Port hereby leases to Tenant, and Tenant hereby leases from Port, the Premises in the Facility identified in the Basic Lease Information. The Premises has the address and contains the square footage specified in the Basic Lease Information. The location and dimensions of the Premises are depicted on *Exhibit A* attached hereto and incorporated herein by reference. Port and Tenant agree and acknowledge that any statement of rentable or usable (if applicable) square footage set forth in this Lease is an approximation which Port and Tenant agree is reasonable and that the usable square footage of the Premises may be less than the rentable square footage of the Premises. Port and Tenant further agree and acknowledge that the rentable square footage of the Premises shall be used at all times to calculate the Base Rent due and payable by Tenant under this Lease and neither the Base Rent nor any other economic term based on rentable square footage shall be subject to revision whether or not the actual rentable or usable square footage is more or less.

(b) Tenant shall have the non-exclusive right to use, together with other tenants, the Common Areas. All of the Common Areas shall at all times be subject to the exclusive control, regulation, and management of Port. Port shall have the right to construct, maintain, and operate lighting facilities on all Common Areas; to patrol all Common Areas; to temporarily close any Common Areas for maintenance, repairs or alterations; from time to time to change the area, level, location and arrangement of Common Area facilities; to use the Common Areas and restrict access and use of the same during the maintenance, repair, construction or reconstruction of buildings, additions or improvements; to erect buildings, additions and improvements on the Common Areas from time to time; and to restrict parking by tenants, their Agents and Invitees. Port may operate and maintain the Common Areas and perform such other acts and make such other changes at any time and from time to time in the size, shape, location, number and extent of the Common Areas or any of them as Port in its sole discretion shall determine; provided, however, that no exercise by Port of its rights hereunder shall unreasonably restrict access to the Premises.

3.2. Accessibility Inspection Disclosure.

California law requires commercial landlords to disclose to tenants whether the property being leased has undergone inspection by a Certified Access Specialist ("CASp") to determine whether the property meets all applicable construction-related accessibility requirements. The law does not require landlords to have the inspections performed. Tenant is hereby advised that the Premises has not been inspected by a CASp and Port shall have no liability or responsibility to make any repairs or modifications to the Premises in order to comply with accessibility standards. The following disclosure is required by law:

"A Certified Access Specialist (CASp) can inspect the subject premises and determine whether the subject premises comply with all of the applicable construction-related accessibility standards under state law. Although state law does not require a CASp inspection of the subject premises, the commercial property owner or lessor may not prohibit the lessee or tenant from obtaining a CASp inspection of the subject premises for the occupancy or potential occupancy of the lessee or tenant, if requested by the lessee or tenant. The parties shall mutually agree on the arrangements for the time and manner of the CASp inspection, the payment of the fee for the CASp inspection, and the cost of making any repairs necessary to correct violations of construction-related accessibility standards within the premises."

3.3. *No Right to Encroach.*

(a) If Tenant (including, its Agents, Invitees, successors and assigns) uses or occupies space outside the Premises without the prior written consent of Port (the "**Encroachment Area**"), then upon written notice from Port ("**Notice to Vacate**"), Tenant shall immediately vacate such Encroachment Area and pay as Additional Rent for each day Tenant used, occupied, uses or occupies such Encroachment Area, an amount equal to the rentable square footage of the Encroachment Area, multiplied by the higher of the (i) highest rental rate then approved by the San Francisco Port Commission for the Premises or the Facility, or (ii) then current fair market rent for such Encroachment Area, as reasonably determined by Port (the "**Encroachment Area Charge**"). If Tenant uses or occupies such Encroachment Area for a fractional month, then the Encroachment Area Charge for such period shall be prorated based on a thirty (30) day month. In no event shall acceptance by Port of the Encroachment Area Charge be deemed a consent by Port to the use or occupancy of the Encroachment Area by Tenant, its Agents, Invitees, successors or assigns, or a waiver (or be deemed as a waiver) by Port of any and all other rights and remedies of Port under this Lease (including Tenant's obligation to Indemnify Port as set forth in Section 3.4(c), at law or in equity.

(b) In addition, Tenant shall pay to Port, as Additional Rent, an amount equaling Two Hundred Dollars (\$200.00) upon delivery of the initial Notice to Vacate plus the actual cost associated with a survey of the Encroachment Area. In the event Port determines during subsequent inspection(s) that Tenant has failed to vacate the Encroachment Area, then Tenant shall pay to Port, as Additional Rent, an amount equaling Three Hundred Dollars (\$300.00) for each additional Notice to Vacate, if applicable, delivered by Port to Tenant following each inspection. The parties agree that the charges associated with each inspection of the Encroachment Area, delivery of each Notice to Vacate and survey of the Encroachment Area represent a fair and reasonable estimate of the administrative cost and expense which Port will incur by reason of Port's inspection of the Premises, issuance of each Notice to Vacate and survey of the Encroachment Area. Tenant's failure to comply with the applicable Notice to Vacate and Port's right to impose the foregoing charges shall be in addition to and not in lieu of any and all other rights and remedies of Port under this Lease, at law or in equity.

(c) In addition to Port's rights and remedies under this Section, the terms and conditions of the indemnity and exculpation provision set forth in Section 19 below (Indemnity and Exculpation) shall also apply to Tenant's (including, its Agents, Invitees, successors and assigns) use and occupancy of the Encroachment Area as if the Premises originally included the Encroachment Area, and Tenant shall additionally Indemnify Port from and against any and all loss or liability resulting from delay by Tenant in surrendering the Encroachment Area including, without limitation, any loss or liability resulting from any Claims against Port made by any tenant or prospective tenant founded on or resulting from such delay and losses to Port due to lost opportunities to lease any portion of the Encroachment Area to any such tenant or prospective tenant, together with, in each case, actual attorneys' fees and costs.

(d) All amounts set forth in this Section shall be due within three (3) business days following the applicable Notice to Vacate and/or separate invoice relating to the actual cost associated with a survey of the Encroachment Area. By signing this Lease, each party specifically confirms the accuracy of the statements made in this Section and the reasonableness of the amount of the charges described in this Section.

3.4. *Proximity of Development Project.* Tenant acknowledges that during the Term, a Port program or project and/or the Development Project(s) described in the Basic Lease Information, if any, is scheduled to be, or may be, constructed on the Premises or on property in the vicinity of the Premises. Tenant is aware that the construction of such project(s) and the activities associated with such construction will generate certain adverse impacts which may result in some inconvenience to or disturbance of Tenant. Impacts may include, but are not limited to, increased vehicle and truck traffic, traffic delays and re-routing, loss of street and

public parking, dust, dirt, construction noise and visual obstructions. Tenant hereby waives any and all Claims against Port, City and their Agents arising out of such inconvenience or disturbance.

3.5. *No Light, Air or View Easement.* This Lease does not include an air, light, or view easement. Any diminution or shutting off of light, air or view by any structure which may be erected on lands near or adjacent to the Facility or by any vessels berthed near the Facility shall in no way affect this Lease or impose any liability on Port, entitle Tenant to any reduction of Base Rent or Additional Rent, or affect this Lease in any way or Tenant's obligations hereunder.

3.6. *Unique Nature of Premises.* Tenant acknowledges that: (a) the Facility is located along the waterfront in a building on a pier and/or wharf, supported by a partially-submerged substructure in a marine environment, which was originally built approximately 100 years ago; and/or (b) the Facility is located along the waterfront adjacent to, on top of, and bayward of the Seawall that is in need of repair and presents increased risk of damage to property and injury or death to persons from seismic events, as further described in Section 3.8; (c) Port's regular maintenance may involve activities, such as pile driving, that create noise and other effects not normally encountered in locations elsewhere in San Francisco due to the unique nature of the Premises; (d) there is a risk that all or a portion of the Premises will be inundated with water due to floods or sea level rise; (e) there is a risk that sea level rise will increase the cost of Substructure repairs and/or prevent or limit the ability to make repairs to the Substructure; and/or (f) Port cannot guarantee that piers, decks, wharves, and aprons will be suitable for leased occupancy during the entire Term of this Lease.

3.7. *Seawall.* The City is engaged in an effort to prepare for a major earthquake and to create more resilient City infrastructure. As part of this effort, the Port is developing a plan to strengthen the Northern Waterfront Seawall which stretches from Fisherman's Wharf to Mission Creek ("**Seawall**") to maintain viability of Port's operations, increase protection of Port and City assets, and enhance life safety in the face of degradation, flooding, earthquakes, climate change, and security hazards. The Seawall was constructed over 100 years ago within the Bay and supports reclaimed land, or fill, and as a result is more vulnerable to seismic risk. Earthquake performance of reclaimed land is an issue for coastal communities worldwide. The *Seawall Earthquake Vulnerability Study of the Northern Waterfront Seawall*, San Francisco, California July 2016 and information about Port and City's resiliency goals and plans and improvements can be found on the Port's website at: <https://www.sfportresilience.com>. Tenant agrees that its waiver of Claims set forth in Section 19 below (Indemnity and Exculpation) is given with full knowledge of the direct or indirect, known or unknown, and foreseeable or unforeseeable losses and claims (including the potential additional risks of injury or death to persons or damage to property) due to the Seawall's condition or the proximity of the Premises to the Bay and the Seawall.

3.8. *As-Is Condition.* Tenant acknowledges and agrees that Tenant is familiar with the Premises, the Premises is being leased and accepted in their "as-is" condition, without any improvements or alterations by Port, without representation or warranty of any kind, and subject to all applicable Laws governing their use, occupancy and possession. Tenant represents and warrants to Port that Tenant has received and reviewed the disclosures regarding the Seawall in Section 3.8 including *The Seawall Earthquake Vulnerability Study of the Northern Waterfront Seawall*, San Francisco, California July 2016 and information on the Port's website; the FEMA disclosure notice attached as **Schedule 3** and a copy of the report(s), if any, relating to the substructure and/or structure of the Facility, as further described in **Schedule 2** attached hereto. Tenant further represents and warrants to Port that Tenant has investigated and inspected, either independently or through agents of Tenant's own choosing, the condition of the Premises and the suitability of the Premises for Tenant's business and intended use. Tenant acknowledges and agrees that neither Port nor any of its agents have made, and Port hereby disclaims, any representations or warranties, express or implied, concerning the rentable area of the Premises,

the physical or environmental condition of the Premises or the Facility (including, but not limited to the substructure and/or the Seawall), the present or future suitability of the Premises for Tenant's business, or any other matter whatsoever relating to the Premises, including, without limitation, any implied warranties of merchantability or fitness for a particular purpose.

3.9. *Reserved Rights Regarding Seawall.* Port has the right to use the Premises on an extended basis without charge, and Tenant shall cooperate by providing access and other reasonably requested assistance at no cost to Port and permit Port and its Agents to enter the Premises upon reasonable prior notice (except in the event of an emergency which poses an imminent danger to public health or safety as determined by Port in its sole discretion) for the purpose of inspecting, repairing and rebuilding the Seawall as Port reasonably deems necessary. Nothing herein shall imply any duty upon the part of Port to perform any work which under any provision of this Lease Tenant may be required to perform or place upon Port any obligation, or liability, for the care, supervision or repair of the Premises or Seawall. If Port elects to perform work on the Seawall within the Premises pursuant to this Section, Port shall not be liable for inconvenience, disturbance, loss of business, nuisance or other damage to Tenant by reason of the performance of such work on the Premises, or on account of bringing necessary materials, supplies and equipment into or through the Premises during the course thereof, provided Port uses commercially reasonable efforts to conduct the activities in a manner that, to the extent reasonably practicable, will minimize inconvenience or disturbance to the activities of Tenant, its Subtenants (if any), and their respective Invitees. In no event will inconvenience or disturbance caused by Port's activities under this Section constitute an actual or constructive eviction of Tenant, entitle Tenant to any abatement or diminution of Rent, or otherwise relieve Tenant from any of its obligations under this Lease. Tenant hereby waives any and all Claims against Port, City and their Agents arising out of any inconvenience or disturbance occasioned by Port's activities under this Section. If use of the Premises is required by Port or its Agents under this Section, then the Parties will coordinate their use of the Premises and use their good faith efforts to minimize adverse impacts to each of their respective needs. Port will have the absolute right to use the Premises without charge in the event of an emergency involving the Seawall.

3.10. *Release and Waiver.* As part of its agreement to accept the Premises in their "As Is With All Faults" condition, Tenant, on behalf of itself and its successors and assigns, will be deemed to waive any right to recover from, and forever release, acquit and discharge, Port and the other Indemnified Parties of and from any and all Claims, whether direct or indirect, known or unknown, foreseen or unforeseen, that Tenant may now have or that may arise on account of or in any way be connected with (i) the physical, geotechnical or environmental condition in, on, under, above, or about the Facility and the Seawall, including any Hazardous Materials in, on, under, above or about the Facility (including soil and groundwater conditions), (ii) the suitability of the Facility and/or the Premises for the development of the Improvements, the Permitted Uses, (iii) any Laws applicable thereto, including Environmental Laws, (iv) damages by death of or injury to any Person, or to property of any kind whatsoever and to whomever belonging, and (v) goodwill, or business opportunities arising at any time and from any cause in, on, around, under, and pertaining to the Facility and/or the Premises, including all claims arising from the joint, concurrent, active or passive negligence of any of Indemnified Parties, but excluding any intentionally harmful acts committed solely by Port or City.

3.11. *Port's Rights Regarding Premises.* Port shall have the full right and authority to make, revoke, impose, and amend any Rules and Regulations pertaining to and reasonably necessary for the proper use, operation and maintenance of the Facility. If no Rules and Regulations currently exist for the Facility, Tenant agrees to be bound by any Rules and Regulations Port later imposes on the Facility. Tenant also acknowledges that Port's exercise of any of its rights regarding the Premises and other Port property in the vicinity of the Premises will not entitle Tenant to any abatement or diminution of Rent.

4. TERM OF LEASE; TERMINATION BY PORT.

4.1. Term. The term of this Lease (the "**Term**") shall be for the period of months specified in the Basic Lease Information commencing on the Commencement Date and expiring on the Expiration Date. If the Commencement Date and Expiration Date occur on a date other than the Commencement Date and the Expiration Date set forth in the Basic Lease Information, then promptly following the actual Commencement Date, Port and Tenant shall execute a Commencement Date and Expiration Date Memorandum substantially in the form attached hereto as **Exhibit B**, confirming the actual Commencement Date and Expiration Date, but either party's failure to do so shall not affect the commencement or expiration of the Term.

If Port is unable to deliver possession of the Premises to Tenant on or before the Commencement Date, then the validity of this Lease shall not be affected thereby and Port shall not be liable to Tenant for any Claims resulting therefrom, and Tenant waives all provisions of any Laws to the contrary. In such case, the Term and regular payments of Rent shall not commence until Port delivers possession of the Premises. Notwithstanding anything to the contrary above, if Port's inability to deliver possession of the Premises on the estimated Commencement Date results from Tenant's or its Agents' acts or omissions, then Base Rent and Additional Rent payable by Tenant hereunder shall commence on the date when Port would have delivered possession of the Premises but for such acts or omissions.

4.2. Termination Rights.

(a) Port has the right to terminate this Lease under this Section when the Premises is needed in connection with a Port program or project. Port may exercise this right without liability or expense, except as specifically set forth in this Section, upon ninety (90) days' prior written notice. Tenant agrees and shall be required to surrender possession of the Premises by the end of the 90-day period.

(b) Port has the right to terminate this Lease under this Section if Port determines, in its sole and absolute discretion, that the condition of the Facility's structures, substructure or utilities has deteriorated to a condition that would create a foreseeable risk of hazard to health or safety. Port may exercise this right without liability or expense, except as specifically set forth in this Section. Port will attempt to provide Tenant with no less than ninety (90) days' prior written notice of termination under this Subsection, but reserves the right to terminate this Lease upon any shorter notice that the Port in its sole and absolute discretion determines is justified given the risk of hazard. Tenant agrees and shall be required to surrender possession of the Premises by the end of the notice period, except as provided in this Section.

For a period ending fifteen (15) calendar days after receipt of Port's notice of termination, Tenant may request Port's consent, in Port's sole and absolute discretion, to allow Tenant to make the repairs required by Port in accordance with this Lease and any additional conditions reasonably imposed by Port, in consideration of Concessions from Port. If Port consents in writing, Port's notice of termination will be deemed rescinded and of no further effect.

(c) Within sixty (60) days after Tenant's surrender under this Section, Port agrees to pay Tenant a portion of those expenses which are documented by Tenant as having been incurred by Tenant prior to the delivery of Port's termination notice in making alterations, additions and improvements to the Premises which were approved in advance and in writing by Port and which were not previously reimbursed to Tenant through rent credits, rent abatement or other form of compensation ("**Improvement Costs**"). Such Improvement Costs shall be determined by the value attributable to any alterations, additions and improvements in any Port building permits for such work obtained by Tenant and which are approved in advance in writing by a Port Property Manager to the extent supported by reasonable evidence of such expenditures provided by Tenant. If no building permits are required for such work, value shall only be attributed to such alterations, additions or improvements if the value is approved in writing by a Port Property Manager prior to the commencement of the work and if the cost is supported by

reasonable evidence of such expenditures provided by Tenant. The portion of the Improvement Costs paid by Port shall be a fraction, of which the numerator shall be the number of months remaining in the initial term of the Lease after Tenant surrenders the Premises, and the denominator shall be the number of months in the initial Term of this Lease, or for work undertaken following the Commencement Date, the number of months beginning at the second month following the Port's approval of the improvements and ending at the Expiration Date of the initial Term of this Lease. In no event shall Port be responsible for paying any moving or relocation expense or other expense incurred by Tenant due to any termination under this Section.

4.3. Waiver of Relocation Benefits. To the extent allowed by applicable Law, Tenant hereby waives any and all rights, benefits or privileges of the California Relocation Assistance Law, California Government Code §§ 7260 et seq., or under any similar law, statute or ordinance now or hereafter in effect, except as specifically provided in this Lease.

5. RENT.

Tenant shall pay to Port, in the manner herein described, the following Rent:

5.1. Base Rent. Throughout the Term, Tenant shall pay to Port the Base Rent set forth in the Basic Lease Information. Tenant shall make the first payment of Base Rent upon execution of this Lease and from and after the Rent Commencement Date, shall pay the Base Rent, in advance, on or before the first day of each calendar month throughout the Term. If the Rent Commencement Date is other than the first day of the month, or the Expiration Date is other than the last day of the month, the Base Rent for those months shall be apportioned based on a thirty (30) day month.

5.2. Default Interest. Any Rent, if not paid within five (5) days following the due date and any other payment due under this Lease not paid by the applicable due date, shall bear interest from the due date until paid at the Interest Rate. However, interest shall not be payable on Late Charges incurred by Tenant nor on other amounts to the extent this interest would cause the total interest to be in excess of that which an individual is lawfully permitted to charge. Payment of interest shall not excuse or cure any default by Tenant. Tenant shall also pay any costs, including attorneys' fees incurred by Port by reason of Tenant's failure to pay Rent or other amounts when due under this Lease.

5.3. Late Charges/Habitual Late Payer. Tenant acknowledges that late payment by Tenant to Port of Rent or other sums due under this Lease will cause Port increased costs not contemplated by this Lease, the exact amount of which will be extremely difficult to ascertain. Accordingly, if Tenant fails to pay Rent on the date due, such failure shall be subject to a Late Charge at Port's discretion. Tenant shall also pay any costs including attorneys' fees incurred by Port by reason of Tenant's failure to timely pay Rent. Additionally, in the event Tenant is notified by Port that Tenant is considered to be a Habitual Late Payer, Tenant shall pay, as Additional Rent, an amount equal to Fifty Dollars (\$50.00) (as such amount may be adjusted from time to time by the Port Commission) upon written notification from Port of Tenant's Habitual Late Payer status. The parties agree that the charges set forth in this Section represent a fair and reasonable estimate of the cost that Port will incur by reason of any late payment. Such charges may be assessed without notice and cure periods and regardless of whether such late payment results in an Event of Default. Payment of the amounts under this Section shall not excuse or cure any default by Tenant.

5.4. Returned Checks. If any check for a payment for any Lease obligation is returned without payment for any reason, Tenant shall pay, as Additional Rent, an amount equal to Fifty Dollars (\$50.00) (as such amount may be adjusted from time to time by the Port Commission) and the outstanding payment shall be subject to a Late Charge as well as interest at the Interest Rate.

5.5. *Net Lease.* It is the purpose of this Lease and intent of Port and Tenant that all Rent shall be absolutely net to Port, so that this Lease shall yield to Port the full amount of the Rent at all times during the Term, without deduction, abatement or offset. Except as otherwise expressly set forth in this Lease, under no circumstances, whether now existing or hereafter arising, and whether or not beyond the present contemplation of the Parties shall Port be expected or required to incur any expense or make any payment of any kind with respect to this Lease or Tenant's use or occupancy of the Premises, including any Improvements. Without limiting the foregoing, but except as expressly provided to the contrary in this Lease, Tenant shall be solely responsible for paying each item of cost or expense of every kind and nature whatsoever, the payment of which Port would otherwise be or become liable by reason of Port's estate or interests in the Premises and any Improvements, any rights or interests of Port in or under this Lease, or the ownership, leasing, operation, management, maintenance, repair, rebuilding, remodeling, renovation, use or occupancy of the Premises, any Improvements, or any portion thereof. No occurrence or situation arising during the Term, nor any present or future Law, whether foreseen or unforeseen, and however extraordinary, shall relieve Tenant from its liability to pay all of the sums required by any of the provisions of this Lease, or shall otherwise relieve Tenant from any of its obligations under this Lease, or shall give Tenant any right to terminate this Lease in whole or in part, except as otherwise expressly provided in this Lease. Tenant waives any rights now or hereafter conferred upon it by any existing or future Law to terminate this Lease or to receive any abatement, diminution, reduction or suspension of payment of such sums, on account of any such occurrence or situation, provided that such waiver shall not affect or impair any right or remedy expressly provided Tenant under this Lease.

5.6. *Additional Charges.* Without limiting Port's other rights and remedies set forth in this Lease, at law or in equity, in the event Tenant fails to submit to the appropriate party, on a timely basis, the items identified in Sections: 12.1 (Utilities), 15.3 (Tenant's Environmental Condition Notification Requirements), 15.8 (Storm Water Pollution Prevention), 28.1(d) (CMD Form), and 32 (Estoppel Certificate) or to provide evidence of the required insurance coverage described in Section 16 below, then upon written notice from Port of such failure, Tenant shall pay, as Additional Rent, an amount equaling One Hundred Dollars (\$100.00). In the event Tenant fails to provide the necessary document within the time period set forth in the initial notice and Port delivers to Tenant additional written notice requesting such document, then Tenant shall pay to Port, as Additional Rent, an amount equaling One Hundred Fifty Dollars (\$150.00) for each additional written notice Port delivers to Tenant requesting such document. The parties agree that the charges set forth in this Section 5.6 represent a fair and reasonable estimate of the administrative cost and expense which Port will incur by reason of Tenant's failure to provide the documents identified in this Section 5.6 and that Port's right to impose the foregoing charges shall be in addition to and not in lieu of any and all other rights under this Lease, at law or in equity. By signing this Lease, each party specifically confirms the accuracy of the statements made in this Section 5.6 and the reasonableness of the amount of the charges described in this Section 5.6.

6. TAXES AND ASSESSMENTS.

6.1. *Payment of Taxes.* During the Term, Tenant agrees to pay, when due, to the proper authority any and all real and personal property taxes, general and special assessments, real property transfer taxes, license fees, permit fees and all other governmental charges of any kind or nature whatsoever, including without limitation all penalties and interest thereon, levied or assessed on the Premises, on Tenant's Property, the leasehold or subleasehold estate or Tenant's use of the Premises, or any transfer of a leasehold interest or subleasehold interest in the Premises (including but not limited to the transfer of the leasehold interest in the Premises pursuant to the Lease) whether in effect at the time this Lease is entered into or which become effective thereafter, and all taxes levied or assessed on the possession, use or occupancy, as distinguished from the ownership, of the Premises. Tenant further recognizes and agrees that its leasehold interest may be subject to the payment of special taxes, including without limitation a

levy of special taxes to finance energy efficiency, water conservation, water pollution control and similar improvements under the Special Tax Financing Law in Chapter 43 Article X of the Administrative Code. Tenant shall not permit any of the above taxes, assessments or other charges to become a defaulted lien on the Premises or the Improvements thereon; provided, however, that in the event any such tax, assessment or similar charge is payable in installments, Tenant may make, or cause to be made, payment in installments; and provided, further, that Tenant may, through such proceeding as Tenant considers necessary or appropriate, contest the legal validity or the amount of any tax, assessment or similar charge so long as such assessment or charge does not become a defaulted lien. In the event of any such dispute, Tenant shall Indemnify Port, City, and their Agents from and against all Claims resulting therefrom.

6.2. Possessory Interest Tax. Tenant recognizes and understands that this Lease may create a possessory interest subject to property taxation and that Tenant may be subject to the payment of property taxes levied on such interest. Tenant further recognizes and understands that any sublease or assignment permitted under this Lease and any exercise of any option to renew or other extension of this Lease may constitute a change in ownership for purposes of property taxation and therefore may result in a revaluation of any possessory interest created hereunder. Tenant agrees to pay taxes of any kind, including, but not limited to, possessory interest taxes, that may be lawfully assessed on the leasehold interest hereby created and to pay all other taxes, excises, licenses, permit charges and assessments based on Tenant's usage of the Premises that may be imposed upon Tenant by Law, all of which shall be paid when the same become due and payable and before delinquency. Tenant agrees not to allow or suffer a lien for any such taxes to be imposed upon the Premises or upon any equipment or property located thereon without promptly discharging the same, provided that Tenant, if so desiring, may have reasonable opportunity to contest the validity of the same. San Francisco Administrative Code Sections 23.38 and 23.39 (or any successor statute) require that certain information relating to the creation, renewal, extension, assignment, sublease, or other transfer of this Lease be reported to the County Assessor within sixty (60) days after any such transaction. Accordingly, Tenant must provide a copy of this Lease to the County Assessor not later than sixty (60) days after the Commencement Date, and any failure of Tenant to timely provide a copy of this Lease to the County Assessor will be a default under this Lease. Tenant will also timely provide any information that Port or City may request to ensure compliance with this or any other reporting requirement.

7. SECURITY DEPOSIT.

Tenant shall pay to Port upon execution of this Lease, in addition to the advance payment of the first month's Base Rent, the Security Deposit, in cash, in the sum specified in the Basic Lease Information, as security for the faithful performance by Tenant of all terms, covenants and conditions of this Lease. If Base Rent is increased beyond the amount set forth in the Basic Lease Information for the last year of the Term, then from and after such increase, Tenant shall increase the amount of the Security Deposit to maintain the same ratio of the Security Deposit to Base Rent as existed on the date immediately prior to such Base Rent increase. Any increase in the Security Deposit shall be delivered to Port on the same date that such increase in Base Rent is first due.

Tenant agrees that Port may (but shall not be required to) apply the Security Deposit in whole or in part to (a) pay any sum due to Port under this Lease; (b) compensate Port for any expense incurred or damage caused by Tenant, its Agents or Invitees; (c) cure any default by Tenant; or (d) cure, or attempt to cure, any failure of Tenant to perform any other covenant, term or condition contained herein. Tenant shall immediately upon demand pay Port a sum equal to the portion of the Security Deposit expended or applied by Port. Port shall not be required to keep the Security Deposit separate from its general funds, and Tenant shall not be entitled to any interest on the Security Deposit. Nothing contained in this Section shall in any way diminish or be construed as waiving any of Port's other remedies set forth in this Lease or provided by law or equity.

Tenant hereby waives the provisions of California Civil Code Section 1950.7 and/or any successor statute, it being expressly agreed that Port may apply all or any portion of the Security Deposit in payment of any and all sums reasonably necessary to compensate Port for any other loss or damage, foreseeable or unforeseeable, caused by the act or omission of Tenant or any Agent or Invitee of Tenant, and that following a default by Tenant, all or any portion of the Security Deposit may be retained by Port following a termination of this Lease and applied to future damages, including damages for future Rent, pending determination of the same.

8. USE OF THE PREMISES.

8.1. Permitted Use. The Premises shall be used and occupied only for the Permitted Use specified in the Basic Lease Information and for no other purpose.

8.2. Prohibited Use. Tenant agrees that the following activities, by way of example only and without limitation, and any other use that is not a Permitted Use (in each instance, a "Prohibited Use" and collectively, "Prohibited Uses"), are inconsistent with this Lease, are strictly prohibited and are considered Prohibited Uses:

(a) any activity, or the maintaining of any object, which is not within the Permitted Use;

(b) any activity, or the maintaining of any object, which will in any way increase the existing rate of, affect or cause a cancellation of, any fire or other insurance policy covering the Premises, any part thereof or any of its contents;

(c) any activity or object which will exceed load restrictions, if any, or cause damage to the Premises;

(d) any activity which constitutes waste or nuisance, including, but not limited to, the preparation, manufacture or mixing of anything that might emit any objectionable odors, noises or lights onto adjacent properties, or the use of loudspeakers or sound or light apparatus which can be heard or seen outside the Premises;

(e) any activity which will in any way injure, obstruct or interfere with the rights of other tenants in the Facility or of owners or occupants of adjacent properties, including, but not limited to, rights of ingress and egress;

(f) use of the Premises for residential, sleeping or personal living quarters and/or "Live/Work" space;

(g) any auction, distress, fire, bankruptcy or going out of business sale on the Premises without the prior written consent of Port, which consent may be granted, conditioned, or withheld in the sole and absolute discretion of Port;

(h) the operation, use, or berthing of any vessels, watercraft or floating barges owned or operated by Tenant;

(i) Tenant's employment of any maritime workers within the Premises for loading, unloading, building, repairing, dismantling, or longshoring of any vessel;

(j) any vehicle and equipment maintenance, including but not limited to, fueling, changing oil, transmission or other automotive fluids;

(k) the storage of any and all excavated materials, including but not limited to, dirt, concrete, sand, asphalt, and pipes;

(l) the storage of any and all aggregate material, or bulk storage, such as wood or of other loose materials;

(m) the washing of any vehicles or equipment; or

(n) other Prohibited Uses identified in the Basic Lease Information, if any.

8.3. Notice of Prohibited Use Charge. In the event Port determines after inspection that Prohibited Uses are occurring, then Tenant shall immediately cease the Prohibited Use and shall pay to Port, as Additional Rent, an amount equaling Two Hundred Dollars (\$200.00) upon delivery of written notice to Tenant to cease the Prohibited Use ("**Notice to Cease Prohibited Use**"). In the event Port determines in subsequent inspection(s) that Tenant has not ceased the Prohibited Use, then Tenant shall pay to Port, as Additional Rent, an amount equaling Three Hundred Dollars (\$300.00) for each additional Notice to Cease Prohibited Use delivered to Tenant. The parties agree that the charges associated with each inspection and delivery of the Notice to Cease Prohibited Use, if applicable, represent a fair and reasonable estimate of the administrative cost and expense which Port will incur by reason of Port's inspection and Tenant's failure to comply with the applicable Notice to Cease Prohibited Use and that Port's right to impose the foregoing charges shall be in addition to and not in lieu of any and all other rights under this Lease, at law or in equity. By signing this Lease, each party specifically confirms the accuracy of the statements made in this Section and the reasonableness of the amount of the charges described in this Section.

9. COMPLIANCE WITH LAWS AND REGULATIONS.

Tenant, at Tenant's sole cost and expense, promptly shall comply with all Laws relating to or affecting the condition, use or occupancy of the Premises and shall comply with all Laws relating to Tenant's specific use of the Facility and all Rules and Regulations, if any, in effect either at the time of execution of this Lease or which may hereafter be in effect at any time during the Term, whether or not the same are now contemplated by the parties. Tenant further understands and agrees that it is Tenant's obligation, at Tenant's sole cost and expense, to cause the Premises and Tenant's activities and operations conducted thereon, to be in compliance with the ADA. Tenant shall be solely responsible for conducting its own independent investigation of this matter and for ensuring that the design of all Alterations and Improvements strictly complies with all requirements of the ADA. If Tenant's use or occupancy of the Premises triggers a requirement to remove barriers or perform other work to any part of the Facility outside of the Premises to comply with the ADA, then, at Port's sole election, Port or Tenant will perform the work at Tenant's sole cost and expense.

The parties acknowledge and agree that Tenant's obligation to comply with all Laws as provided herein is a material part of the bargained for consideration under this Lease. Tenant's obligation under this Section 9 shall include, without limitation, the responsibility of Tenant to make substantial or structural repairs and Alterations to the Premises, regardless of, among other factors, the relationship of the cost of curative action to the Rent under this Lease, the length of the then remaining Term hereof, the relative benefit of the repairs to Tenant or Port, the degree to which the curative action may interfere with Tenant's use or enjoyment of the Premises, the likelihood that the parties contemplated the particular Laws involved, and whether the Laws involved are related to Tenant's particular use of the Premises. Any Alteration or Improvements made by or on behalf of Tenant pursuant to the provisions of this Section 9 shall comply with the provisions of Section 13 below. Except as otherwise expressly set forth in this Lease, no occurrence or situation arising during the Term, nor any present or future Law, whether foreseen or unforeseen, and however extraordinary, shall relieve Tenant of its obligations hereunder, nor give Tenant any right to terminate this Lease in whole or in part or to seek redress against Port, except to the extent Tenant may have remedies against Port pursuant to this Lease or applicable Law. Tenant waives any rights now or hereafter conferred upon it by any existing or future Law to terminate this Lease, to receive any abatement, diminution, reduction or suspension of payment of Rent, or to compel Port to make any repairs to comply with any such Laws, on account of any such occurrence or situation.

10. PORT ACTING AS OWNER OF PROPERTY; REGULATORY APPROVALS; COMPLIANCE WITH CITY'S RISK MANAGER'S REQUIREMENTS.

10.1. *Port Acting as Owner of Property.* Tenant understands and agrees that Port is entering into this Lease in its capacity as a landowner with a proprietary interest in the Premises and not as a Regulatory Agency of the City with certain police powers. By entering into this Lease, Port is in no way modifying or limiting the obligation of Tenant to obtain any required Regulatory Approvals from Regulatory Agencies, and to cause the Premises to be used and occupied in accordance with all Laws and required Regulatory Approvals. Examples of Port actions as a Regulatory Agency include Port issuance of building, encroachment and other construction-related permits, and the Chief Harbor Engineer's actions to protect public health and safety.

10.2. *Regulatory Approvals.* Tenant understands that Tenant's operations on the Premises, changes in use, or Improvements or Alterations to the Premises (individually and collectively, "**Changes**") may require Regulatory Approvals, including Regulatory Approvals issued by Port in its capacity as a Regulatory Agency.

Tenant shall be solely responsible for obtaining any Regulatory Approvals, and Tenant shall not seek any Regulatory Approval without first obtaining the prior written approval of Port. All costs associated with applying for and obtaining any necessary Regulatory Approval shall be borne solely and exclusively by Tenant. Tenant shall be solely responsible for complying with any and all conditions imposed by Regulatory Agencies as part of a Regulatory Approval; provided, however, Tenant shall not agree to the imposition of conditions or restrictions in connection with its efforts to obtain a permit or other entitlement from any Regulatory Agency (other than Port), if the Port is required to be a co-permittee under such permit or other entitlement, or if the conditions or restrictions it would impose on the project could affect use or occupancy of the Facility or Port's interest therein or would create obligations on the part of Port (whether on or off of the Premises) to perform or observe, unless in each instance Port has previously approved such conditions in writing, in Port's sole and absolute discretion.

Any fines or penalties imposed as a result of the failure of Tenant to comply with the terms and conditions of any Regulatory Approval shall be promptly paid and discharged by Tenant, and Port shall have no liability, monetary or otherwise, for any fines and penalties. To the fullest extent permitted by Law, Tenant agrees to Indemnify City, Port and their Agents from and against any Claim which City or Port may incur as a result of Tenant's failure to obtain or comply with the terms and conditions of any Regulatory Approval.

Without limiting the terms and conditions of Sections 10.1 and 10.2, by signing this Lease, Tenant agrees and acknowledges that (i) Port has made no representation or warranty that Regulatory Approvals to allow for the Changes, if any, can be obtained, (ii) although Port is an agency of the City, Port has no authority or influence over any Regulatory Agency responsible for the issuance of such required Regulatory Approvals, (iii) Port is entering into this Lease in its capacity as a landowner with a proprietary interest in the Facility and not as a Regulatory Agency of the City with certain police powers, and (iv) Tenant is solely responsible for obtaining any and all required Regulatory Approvals in connection with any Changes. Accordingly, Tenant understands that there is no guarantee, nor a presumption, that any required Regulatory Approvals will be issued by the appropriate Regulatory Agency and Port's status as an agency of the City shall in no way limit the obligation of Tenant to obtain approvals from any Regulatory Agencies (including Port) that have jurisdiction over the Facility. Tenant hereby releases and discharges Port from any liability relating to the failure of any Regulatory Agency (including Port) from issuing any required Regulatory Approval.

10.3. *Compliance with City's Risk Manager's Requirements.* Tenant shall faithfully observe, at no cost to Port, any and all requirements of City's Risk Manager with respect to Tenant's use and occupancy of the Premises, so long as such requirements do not unreasonably

interfere with Tenant's use of the Premises or are otherwise connected with standard prudent commercial practices of other landlords.

11. MAINTENANCE AND REPAIRS.

11.1. *Tenant Maintenance and Repair Obligations.* Unless otherwise set forth in the Basic Lease Information, Tenant shall at all times during the Term, starting on the Commencement Date, including any period of early entry under this Lease, or occupancy or use of the Premises by Tenant under another lease or license with Port for the same Premises, and at its sole cost and expense, maintain, repair and replace in good and working order, condition and repair the Premises and all Improvements and Alterations thereon, including, but not limited to, glazing. Port shall not be obligated to make any repairs, replacement or renewals of any kind, nature or description whatsoever to the Premises nor to any Improvements or Alterations now or hereafter located thereon. Tenant hereby waives all rights to make repairs at Port's expense under Sections 1932(1), 1941 and 1942 of the California Civil Code or under any similar Law now or hereafter in effect. Notwithstanding any maintenance obligations of Port that may be set forth in the Basic Lease Information, in the event that Tenant, its Agents or Invitees cause any damage to the Premises or any other property within Port's jurisdiction, Tenant shall be responsible for repair and Port may repair the same at Tenant's sole cost and expense and Tenant shall immediately reimburse Port therefor.

Tenant shall not make, nor cause or suffer to be made, any repairs or other work for which a permit is required by any applicable building code, standard or regulation, including, without limitation, the Port Building Code or of any rule or regulation of Port without first obtaining Port's prior written consent and a permit therefor.

In the event that damage or deterioration to the Premises or any portion thereof which is Tenant's obligation to maintain results in the same not meeting the standard of maintenance required by Port for such uses as Tenant is making of the Premises, then Tenant shall have the independent responsibility for, and shall promptly undertake, maintenance or repair of the Premises and complete the same with due diligence.

11.2. *Port's Right to Inspect.* Without limiting Section 24 below, Port may make periodic inspections of the Premises and may advise Tenant when maintenance or repair of the Premises is required, but such right of inspection shall not relieve Tenant of its independent responsibility to maintain such Premises and Improvements in a condition as good as, or better than, their condition at the Commencement Date, excepting ordinary wear and tear.

11.3. *Port's Right to Repair.* In the event Tenant fails to maintain the Premises in accordance with this Lease or Tenant fails to promptly repair any damage to the Facility or the Facility Systems caused by Tenant or its Agents, Port may repair the same at Tenant's sole cost and expense and Tenant shall immediately reimburse Port therefore. If the cost (including, but not limited to, salaries of Port staff and attorneys' fees) of any such repairs or replacements made at Tenant's expense is in excess of Two Thousand Dollars (\$2,000), then Tenant shall pay to Port an administrative fee equal to ten percent (10%) of the total "**Hard costs**" of the work. "**Hard costs**" shall include the cost of materials and installation, but shall exclude any costs associated with design, such as architectural fees. With respect to any work where the total hard costs of such work are less than Two Thousand Dollars (\$2,000), Tenant shall pay to Port, as Additional Rent, an amount equaling Two Hundred Dollars (\$200).

In addition, upon delivery of the initial notice relating to Tenant's failure to maintain the Premises in accordance with Section 11 ("**Maintenance Notice**"), Tenant shall pay, as Additional Rent, an amount equaling Two Hundred Dollars (\$200.00). In the event Port determines during subsequent inspection(s) that Tenant has failed to maintain the Premises in accordance with Section 11, then Tenant shall pay to Port, as Additional Rent, an amount equaling Three Hundred Dollars (\$300) for each additional Maintenance Notice, if applicable, delivered by Port to Tenant following each inspection. By signing this Lease, each party specifically agrees that the charges

associated with each inspection of the Premises and delivery of each Maintenance Notice represent a fair and reasonable estimate of the administrative cost and expense which Port will incur by reason of Port's inspection of the Premises and issuance of each Maintenance Notice. Tenant's failure to comply with the applicable Maintenance Notice and Port's right to impose the foregoing charges shall be in addition to and not in lieu of any and all other rights and remedies of Port under this Lease, at law or in equity. The amounts set forth in this Section shall be due within three (3) business days following delivery of the applicable Maintenance Notice.

For purposes of this Lease, the term "**ordinary wear and tear**" shall not include any deterioration in the condition or diminution of the value of any portion of the Premises and/or the Facility in any manner whatsoever related directly or indirectly to Tenant's failure to comply with the terms and conditions of this Lease.

11.4. Acts of Nature. Nothing contained herein shall require Port to repair or replace the Premises or the Improvements thereon as a result of damage caused by acts of war, earthquake, tidal wave or other acts of nature, except that this provision shall not affect any obligation to make repairs to the Premises pursuant to Section 17 in the event of any damage or destruction of the Premises.

12. UTILITIES AND SERVICES.

12.1. Utilities. Except as may be otherwise provided in the Basic Lease Information, Tenant shall make arrangements and shall pay all charges for all Utilities to be furnished on, in or to the Premises or to be used by Tenant. Tenant shall procure all electricity for the Premises from the San Francisco Public Utilities Commission at rates to be determined by the SF Public Utilities Commission. If the SF Public Utilities Commission determines that it cannot feasibly provide service to Tenant, Tenant may seek another provider.

Tenant shall be obligated, at its sole cost and expense, to repair and maintain in good operating condition all utilities serving the Premises (whether within or outside the Premises and regardless of who installed same). The obligation to repair and maintain includes the obligation to routinely inspect and assess such Utilities using qualified licensed professionals and to report the results of such inspections to Port. Tenant shall coordinate with Port and impacted Port tenants, if necessary, with respect to maintenance and repair of any off-Premises utility infrastructure, including providing advance notice of maintenance and repair requirements.

Tenant shall not, without the written consent of Port, which consent may be granted or withheld in Port's sole and absolute discretion, use any apparatus or device in the Premises using current in excess of 110 volts or which will in any way increase the amount of electricity usually furnished or supplied for use of the Premises, including without limitation, electronic data processing machines. If Tenant requires electric current in excess of that usually furnished or supplied for the Premises, Tenant shall first procure the written consent of Port, which Port may refuse, in its sole and absolute discretion, to the use thereof, and Port may cause an electric current meter to be installed in the Premises so as to measure the amount of electric current consumed for any such other use. The cost of any such meter and of installation, maintenance, and repair thereof shall be paid for solely by Tenant and Tenant agrees to pay to Port promptly upon demand therefor by Port for all such electric current consumed, as shown by the meter, at the rates charged for such service by the San Francisco Public Utilities Commission or the local public utility, as the case may be, furnishing the same, plus any additional expense incurred in keeping account of the electric current so consumed.

The parties agree that any and all utility improvements (not including telephone wiring and equipment) shall become part of the realty and are not trade fixtures or Tenant's Property. Port makes no representation or warranty that utility services, including telecommunications services, will not be interrupted. Port shall not be liable in damages or otherwise for any failure or interruption of any utility services, including telecommunications services, furnished to the Premises. No such failure or interruption shall constitute a basis for constructive eviction, nor

entitle Tenant to terminate this Lease or abate Rent. Tenant hereby waives the provisions of California Civil Code Section 1932(1), 1941, and 1942, or any other applicable existing or future Laws permitting the termination of this Lease due to such interruption, failure or inability.

In the event any Law imposes mandatory or voluntary controls on Port, the Facility, or the property or any part thereof, relating to the use or conservation of energy, water, gas, light or electricity or the reduction of automobile or other emissions, or the provision of any other utility or service provided with respect to this Lease, or in the event Port is required or elects to make alterations to any part of the Facility in order to comply with such mandatory or voluntary controls or guidelines, such compliance and the making of such alterations shall in no event entitle Tenant to any damages, relieve Tenant of the obligation to pay the full Base Rent and Additional Rent reserved hereunder or to perform each of its other covenants hereunder or constitute or be construed as a constructive or other eviction of Tenant. Port shall have the right at any time to install a water meter in the Premises or otherwise to measure the amount of water consumed on the Premises, and the cost of such meter or other corrective measures and the installation and maintenance thereof shall be paid for by Tenant.

Without Port's prior written consent, which Port may give or refuse in its sole and absolute discretion, Tenant shall not place or install in the Premises any equipment that weighs in excess of the normal load-bearing capacity of the floors of the Facility or the pier, as applicable, and as may be further described in the Basic Lease Information. If Port consents to the placement or installation of any such machine or equipment in the Premises, Tenant, at no cost to Port, shall reinforce the floor of the Premises, pursuant to plans and specifications approved by Port and otherwise in compliance with Section 13 below, to the extent necessary to assure that no damage to the Premises or the Facility or weakening of any structural or substructural supports, as the case may be, will be occasioned thereby.

12.2. Services. Except as may be otherwise provided in the Basic Lease Information, Tenant shall make arrangements and shall pay all charges for all services to be furnished on, in or to the Premises or to be used by Tenant, including, without limitation, garbage and trash collection, janitorial service and extermination service.

12.3. On-Site Renewable Energy. At any time during the Term, Port shall have the right, at its sole and absolute discretion, to install, or cause another party to install, a renewable energy system, using sources such as solar (photovoltaic or solar thermal power), wind, tidal or biofuel power ("**Renewable Energy System**") on the roof of the Facility or otherwise on or near the Premises for the purpose of supplying power to the Facility or other locations. Notwithstanding Section 12.1, unless the cost per kilowatt of power to Tenant from such Renewable Energy System is greater than the cost per kilowatt Tenant would otherwise pay for power, Tenant shall purchase all or a portion of its power needs from the operator of the Renewable Energy System.

12.4. Energy Consumption Disclosure. Tenant consents to Tenant's utility service providers disclosing energy use data for the Premises to City for use under California Public Resources Code Section 25402.10, as implemented under California Code of Regulations Sections 1680–1685, and San Francisco Environment Code Chapter 20, as each may be amended from time to time ("**Energy Consumption Reporting Laws**"), and for such data to be publicly disclosed under the Energy Consumption Reporting Laws.

13. IMPROVEMENTS AND ALTERATIONS.

13.1. Port Consent Required.

(a) Tenant shall not make nor cause or suffer to be made, any Alterations or Improvements to the Premises (i) without the prior written consent of Port, which consent shall not be unreasonably withheld; provided, however, that Port shall have the right in its sole and absolute discretion to consent or to withhold its consent to any Alterations or Improvements which affect the structural portions of the Premises, the Facility or the Facility Systems, and (ii) until Tenant shall have procured and paid for all Port and other Regulatory Approvals of the

various Regulatory Agencies having jurisdiction over the Premises, including, but not limited to, any building or similar permits required by Port or its Chief Harbor Engineer in the exercise of its jurisdiction with respect to the Premises.

(b) As a condition to giving consent, Port may require Tenant to provide Port, at Tenant's sole cost and expense, one or more financial guarantees, each in a form and issued by a bank or surety acceptable to Port, such as: (i) a standby letter of credit or bond; and/or (ii) a payment and performance bond from Tenant's Contractors naming Port as co-obligee, each in a principal amount up to one hundred fifty percent (150%) but not less than one hundred percent (100%) of the estimated costs of the Alteration or Improvement, to ensure Port against any liability for mechanics' and materialmen's liens, stop notices and to ensure completion of work.

(c) At least thirty (30) days before commencing any Alterations or Improvements to the Premises, Tenant shall notify Port. Tenant's notice shall be accompanied by final construction documents for the Alterations or Improvements, if applicable. Port shall have the right to object to any of the Alterations or Improvements within sixty (60) days after receipt of notice from Tenant. Port's failure to notify Tenant of Port's consent within the 60-day period shall be deemed Port's disapproval of the Alterations.

(d) None of the following will constitute Alterations or Improvements requiring Port's consent, unless the installation will affect Facility Systems or the structure of the building: (i) installation of furnishings, trade fixtures, equipment, or decorative improvements; (ii) painting the interior of the Premises; and (iii) carpeting the Premises.

13.2. Construction Requirements. All Alterations and Improvements to the Premises made by or on behalf of Tenant shall be subject to the following conditions, which Tenant covenants faithfully to perform:

(a) All Alterations and Improvements shall be performed in a good and workmanlike manner in accordance with plans and specifications previously approved by Port in writing and in compliance with the applicable building, zoning and other applicable Laws, including, but not limited to, compliance with the ADA, and in compliance with the terms of and conditions imposed in any Regulatory Approval or any permit or authorization for the Premises.

(b) All Alterations and Improvements shall be performed at the sole cost and expense of Tenant, with reasonable dispatch and prosecuted to completion, and only by duly licensed and bonded contractors or mechanics approved by Port, and subject to any conditions that Port may reasonably impose.

(c) Tenant, while performing any subsequent construction or maintenance or repair of the Improvements (for purposes of this Section only, "Work"), shall undertake commercially reasonable measures in accordance with good construction practices to minimize the risk of injury or damage to adjoining portions of the Premises and Improvements and the surrounding property, or the risk of injury to members of the public, caused by or resulting from the performance of its Work. Tenant shall undertake commercially reasonable measures to minimize damage, disruption or inconvenience caused by the Work and make adequate provision for the safety and convenience of all persons affected by the Work. Dust, noise and other effects of the Work shall be controlled using commercially-accepted methods customarily used to control deleterious effects associated with construction projects in populated or developed urban areas. Tenant shall erect appropriate construction barricades substantially enclosing the area of such construction and maintain them until the Work has been substantially completed, to the extent reasonably necessary to minimize the risk of hazardous construction conditions.

(d) At the completion of any Work described in this Section, Tenant shall furnish to Port one reproducible "as built" drawing of all Alterations and Improvements made in the Premises. If Tenant fails to provide such as-built drawings to Port within sixty (60) days after completion of the Improvements, Port, after giving notice to Tenant shall have the right, but not the obligation, to cause the preparation by an architect of Port's choice of "as-built" drawings, at

Tenant's sole cost, to be paid by Tenant to Port within thirty (30) days after Port's request therefor.

(e) Tenant expressly acknowledges that the facility is a contributing resource to the Port of San Francisco Embarcadero Historic District on the National Register. Accordingly, all interior and exterior Alterations (including but not limited to, any repair, alteration, improvement, or construction to the interior or exterior of the Facility) are subject to review by Port for consistency with the design policies and criteria set forth in the Waterfront Land Use Plan, Design and Access Element, the Secretary of the Interior's Standards for the Treatment of Historic Properties, which are published by the National Park Service and posted on its website at <http://www.nps.gov/history/hps/tps/Standards/index.htm> (the "**Secretary's Standards**") and summarized in the attached *Exhibit D*, and the Port of San Francisco Historic Preservation Review Guidelines for Pier and Bulkhead Wharf Substructures attached hereto as *Exhibit E* ("**Port's Guidelines**"). Tenant expressly agrees to comply with the Secretary's Standards for all current and future interior and exterior repair, alteration, improvement or construction. Additionally, Tenant expressly agrees to comply with Port's Guidelines as applicable.

(f) Without limiting Section 15 below (Hazardous Materials), in the event that asbestos-containing materials ("**ACM**") are determined to exist in or about the Premises, Tenant shall ensure that all Alterations and Improvements and any asbestos related work, as further defined in California Health & Safety Code Section 25914.1(b), is performed in compliance with all Laws relating to asbestos, including but not limited to, Cal-OSHA regulations found in Title 8 of the California Code of Regulations, Sections 1502 and 1529. Additionally, Tenant shall distribute notifications to all employees and contractors as required pursuant to California Health & Safety Code Sections 25915 et seq. informing them of the existence of ACM and that moving, drilling, boring, or otherwise disturbing ACM may present a health risk and should not be attempted by an unqualified employee. No Alterations or Improvements affecting ACM-containing areas or any asbestos related work shall be performed without Port's prior written consent in each instance.

(g) Tenant, on behalf of itself and its Agents or Invitees, shall comply with all requirements of the Port Building Code, Section 3424, and all other Laws, including, without limitation, the California and United States Occupational Health and Safety Acts and their implementing regulations, when the work of Alterations or Improvements disturbs or removes lead-based or presumed lead-based paint (as described below). Tenant and its Agents or Invitees shall give to Port three (3) business days prior written notice of any disturbance or removal of lead-based or presumed lead-based paint. Further, Tenant and its Agents or Invitees, when disturbing or removing lead-based or presumed lead-based paint, shall not use or cause to be used any of the following methods: (a) acetylene or propane burning and torching; (b) scraping, sanding or grinding without containment barriers or a High Efficiency Particulate Air filter ("**HEPA**") local vacuum exhaust tool; (c) hydroblasting or high-pressure wash without containment barriers, without Port's prior written consent; (d) abrasive blasting or sandblasting without containment barriers or a HEPA vacuum exhaust tool, without Port's prior written consent; and (e) heat guns operating above 1,100 degrees Fahrenheit. Paint on the interior and exterior of buildings built before December 31, 1978, is presumed to be lead-based paint unless lead-based paint testing, as defined in Section 3424 of the Port Building Code, demonstrates an absence of lead-based paint on the surfaces of such buildings. Under this Section 13.2(g), lead-based paint is "**disturbed or removed**" if the work of Alterations or Improvements involves any action that creates friction, pressure, heat or a chemical reaction upon any lead-based or presumed lead-based paint on an interior or exterior surface so as to abrade, loosen, penetrate, cut through or eliminate paint from that surface.

13.3. Improvements Part of Realty. Except as set forth in Section 13.4 below, all Alterations and Improvements constructed on or affixed to the Premises by or on behalf of Tenant shall immediately upon construction or installation become part of the realty owned by Port and shall, at the end of the Term hereof, remain on the Premises without compensation to

Tenant. Tenant may not remove any such property at any time during or after the Term unless Port so requires as further provided in Section 25 (Surrender).

13.4. Removal of Improvements. Prior to the Expiration Date or earlier termination of this Lease, Port may give written notice to Tenant (herein "**Notice of Removal**") specifying the Alterations or Improvements that are designated as Tenant's Property as defined in this Lease or as may be specifically provided in the relevant permits or plans approved by Port, which Tenant shall be required to remove and relocate or demolish and remove from the Premises in accordance with Section 25. Any such removal is subject to the requirements of this Section, including the requirement to obtain a Port building or similar permit. If termination of this Lease is the result of loss or destruction of the Premises or any Improvements thereon, Port shall deliver the Notice of Removal to Tenant within a reasonable time after the loss or destruction. Tenant shall be obligated at its own expense to remove all Alterations or Improvements specified in the Notice of Removal, including without limitation all telephone wiring and equipment installed by Tenant. Tenant shall promptly repair, at its own expense, in good and workmanlike fashion any damage occasioned thereby. If Tenant fails to complete any required demolition or removal on or before the termination of this Lease, Port may perform such removal or demolition at Tenant's expense, and Tenant shall reimburse Port within three (3) business days after demand therefor.

13.5. Removal of Non-Permitted Improvements. If Tenant constructs any Alterations or Improvements without Port's prior written consent or without complying with Section 13.2 above, then, in addition to any other remedy available to Port, Port may require Tenant to remove, at Tenant's expense, any or all such Alterations or Improvements and to promptly repair, at Tenant's expense and in good workmanlike fashion, any damage occasioned thereby. Tenant shall pay to Port all special inspection fees as set forth in any applicable building code, standard or regulation, including, without limitation, the Port Building Code, for inspection of work performed without required permits. The foregoing obligation of Tenant to reimburse Port for all cost and expenses incurred by Port in connection with Tenant's failure to comply with the provisions of Section 13 shall survive the expiration or earlier termination of this Lease.

13.6. All-Gender Toilet Facilities. If applicable, Tenant shall comply with San Francisco Administrative Code Section 4.1-3 requiring at least one all-gender toilet facility on each floor of any new building on City-owned land and within existing buildings leased by the City, including the Premises, where extensive renovations are made. An "**all-gender toilet facility**" means a toilet that is not restricted to use by persons of a specific sex or gender identity by means of signage, design, or the installation of fixtures, and "**extensive renovations**" means any renovation where the construction cost exceeds 50% of the cost of providing the toilet facilities required by this section. If Tenant has any question about applicability or compliance, Tenant should contact the Port's Property Manager for guidance.

13.7. Signs. Tenant shall not install business signage, awnings or other exterior decoration or notices on the Premises without Port's prior written consent. Any sign that Tenant is permitted to place, construct or maintain on the Premises shall comply with all Laws relating thereto, including but not limited to, Port's Sign Guidelines, as revised by Port from time to time, and building permit requirements, and Tenant shall obtain all Regulatory Approvals required by such Laws. Port makes no representation with respect to Tenant's ability to obtain such Regulatory Approval. Tenant, at its sole cost and expense, shall remove all signs placed by it on the Premises at the expiration or earlier termination of this Lease.

13.8. Improvements on Roof. Tenant shall not install any equipment on the roof or any other part of the Facility outside of the Premises without Port's prior written consent. If Port consents, then Tenant shall have a non-exclusive revocable license on and over the roof and/or other areas of the Facility necessary to install, maintain and repair the equipment in a location mutually agreeable to Port and Tenant, subject to and consistent with all necessary Regulatory Approvals, including a building or encroachment permit issued by Port. Port makes no

representation with respect to Tenant's ability to obtain such Regulatory Approvals. Tenant's use of any licensed areas shall be subject to all the terms and conditions of this Lease and Tenant shall have the obligations and liabilities as if the licensed areas are included in the Premises under this Section, and Sections 3.9, 9-11, 13, 15, 16, 19 and 25 of this Lease. The license granted to Tenant hereunder is for the sole purpose of constructing, maintaining, restoring, replacing and operating Tenant's approved equipment, including any necessary conduits, only in connection with Tenant's Permitted Uses under this Lease and Tenant shall not have the right to install any other equipment outside of the Premises, including without limitation a telecommunications (cell) site or any other equipment that can be used for any and commercial purpose. The license granted hereby includes the right of ingress and egress through the Facility during non-business hours for access to or from the Premises and Tenant's equipment, provided that Tenant must notify the Port's Property Manager at least 24 hours in advance of any access and shall comply with all reasonable requirements of such designated person with respect to Tenant's requested access. In the event of an emergency, Tenant shall have the right to enter the licensed areas provided it makes good faith efforts to notify Port in advance of such entry.

13.9. Port's Alterations. Port reserves the right at any time to make Alterations, additions, repairs, deletions or improvements to the Common Areas or any other part of the Facility, the Facility Systems, or adjacent Port property ("**Port Work**"). Port shall use commercially reasonable efforts to conduct any of the foregoing activities in a manner that, to the extent reasonably practicable, will minimize inconvenience or disturbance to Tenant; Port will have no obligation to minimize inconvenience or disturbance to Tenant for Port Work when the Port Work is necessary, in Port's sole and absolute discretion, to maintain Port property in safe, hazard-free condition. In no event will inconvenience or disturbance caused by Port Work constitute an actual or constructive eviction of Tenant, entitle Tenant to any abatement or diminution of Rent, or otherwise relieve Tenant from any of its obligations under this Lease. Tenant hereby waives any and all Claims against Port, City and their Agents arising out of any inconvenience or disturbance occasioned by Port Work.

14. LIENS.

Tenant shall keep the Premises free from any liens arising out of any work performed, materials furnished or obligations incurred by Tenant or its Agents. In the event that Tenant shall not, within twenty (20) days following the imposition of any such lien, cause the same to be released of record, Port shall have, in addition to all other remedies provided by this Lease or by Law, the right but not the obligation to cause the same to be released by such means as it shall deem proper, including without limitation, payment of the claim giving rise to such lien. All sums paid by Port for such purpose, plus interest at the Interest Rate, and all reasonable expenses incurred by Port in connection therewith (including, without limitation, reasonable attorneys' fees) shall be payable to Port by Tenant upon demand. Port shall have the right to post on the Premises any notices that Port may deem proper for the protection of Port, the Premises, and the Facility, from mechanics' and materialmen's liens. Tenant shall give to Port at least fifteen (15) days' prior written notice of commencement of any Alteration, repair or construction on the Premises. Tenant agrees to Indemnify Port, City and their respective Agents from and against any Claims for mechanic's, materialmen's or other liens in connection with any Alterations, repairs or construction on the Premises, or materials furnished or obligations incurred by or for Tenant.

Without limiting the foregoing, Tenant shall not create, permit or suffer any liens or encumbrances affecting any portion of the Premises, the Facility or Port's interest therein or under this Lease.

15. HAZARDOUS MATERIALS.

15.1. Requirements for Handling. Neither Tenant nor its Agents or Invitees may Handle or permit any other person to Handle any Hazardous Material in, on, under or about the Premises, any other part of the Facility, or other Port property, subject only to the following

exceptions, provided that Handling is at all times in full compliance with all Environmental Laws: janitorial and office supplies in limited amounts customarily used for general office purposes.

15.2. *Tenant Responsibility.* Tenant agrees to protect its Agents and Invitees in its operations on the Premises from hazards associated with Hazardous Materials in accordance with all Environmental Laws and also agrees, for itself and on behalf of its Agents and Invitees, that during its use and occupancy of the Premises, each of them:

(a) will not permit any Hazardous Materials to be present in, on, under or about the Premises, any other part of the Facility, or other Port property except as permitted under Section 15.1;

(b) will not cause or permit any Hazardous Material Condition; and

(c) will comply with all Environmental Laws relating to the Premises and any Hazardous Material Condition, and will not engage in or permit any activity at the Premises, any other part of the Facility, other Port property, or in the operation of any vehicles or vessels used in connection with the Premises in violation of any Environmental Laws.

15.3. *Tenant's Environmental Condition Notification Requirements.*

(a) Tenant must notify Port immediately, orally or by other means that will transmit the earliest possible notice to Port staff, followed within twenty-four (24) hours by written notice, of and when Tenant learns or has reason to believe Hazardous Materials were Released or, except as allowed under Section 15.1, Handled, in, on, or about the Premises, the Facility, other Port property, or the environment, or from any vehicles or vessels that Tenant or its Agents or Invitees use during Tenant's occupancy of the Premises, whether or not the Release or Handling is in quantities that would be required under Environmental Laws to be reported to an Environmental Regulatory Agency.

(b) Tenant must notify Port immediately, orally or by other means that will transmit the earliest possible notice to Port staff, followed within twenty-four (24) hours by written notice, and contemporaneously provide Port with an electronic copy, of:

(i) Any notice of the Release or Handling of Hazardous Materials, in, on, or about the Premises, the Facility, other Port property, or the environment, or from any vehicles or vessels Tenant, or its Agents and Invitees uses during Tenant's occupancy of the Premises that Tenant or its Agents or Invitees provides to an Environmental Regulatory Agency;

(ii) Any notice of a violation, or a potential or alleged violation, of any Environmental Law that Tenant or its Agents or Invitees receives from any Environmental Regulatory Agency;

(iii) Any other Environmental Regulatory Action that is instituted or threatened by any Environmental Regulatory Agency against Tenant or its Agents or Invitees and that relates to the Release or Handling of Hazardous Materials, in, on, or about the Premises, the Facility, other Port property, or the environment, or from any vehicles or vessels Tenant, or its Agents and Invitees uses during Tenant's occupancy of the Premises;

(iv) Any Hazardous Material Claim that is instituted or threatened by any third party against Tenant or its Agents or Invitees and that relates to the Release or Handling of Hazardous Materials, in, on, or about the Premises, the Facility, other Port property, or the environment, or from any vehicles or vessels Tenant, or its Agents and Invitees uses during Tenant's occupancy of the Premises; and

(v) Any notice of the termination, expiration, or substantial amendment of any Environmental Regulatory Approval needed by Tenant or its Agents or Invitees for their operations at the Premises.

(c) Tenant must notify Port of any meeting, whether conducted face-to-face or telephonically, between Tenant and any Environmental Regulatory Agency regarding an Environmental Regulatory Action. Port will be entitled to participate in any such meetings at its sole election.

(d) Tenant must notify Port of any Environmental Regulatory Agency's issuance of an Environmental Regulatory Approval. Tenant's notice to Port must state the issuing entity, the Environmental Regulatory Approval identification number, and the date of issuance and expiration of the Environmental Regulatory Approval. In addition, Tenant must provide Port with a list of any plan or procedure required to be prepared and/or filed with any Environmental Regulatory Agency for operations on the Premises, including a "Spill Prevention Control and Countermeasure Plan." Tenant must provide Port with copies of any of the documents within the scope of this section upon Port's request.

(e) Tenant must provide Port with copies of all communications with Environmental Regulatory Agencies and all non-privileged communications with other persons regarding potential or actual Hazardous Material Claims arising from Tenant's or its Agents' or Invitees' operations at the Premises. Upon Port's request, Tenant must provide Port with a log of all communications withheld under a claim of privilege that specifies the parties to and subject of each withheld communication.

(f) Port may from time to time request, and Tenant will be obligated to provide, information reasonably adequate for Port to determine that any and all Hazardous Materials are being Handled in a manner that complies with all Environmental Laws.

15.4. Requirement to Remediate.

(a) Tenant's Remediation obligations under this subsection are subject to subsection (b).

(i) After notifying Port in accordance with Section 15.3(a), Tenant must Remediate at its sole cost in compliance with all Environmental Laws and this Lease, any Hazardous Material Condition occurring during the Term or while Tenant or its Agents or Invitees otherwise occupy any part of the Premises. Tenant must obtain Port's approval of a Remediation work plan, whether or not required under Environmental Laws, then begin Remediation actions immediately following Port's approval of the work plan and continue diligently until Remediation is complete, as determined by Port, in its sole discretion.

(ii) In addition to its obligations under clause (i), before this Lease terminates for any reason, Tenant must Remediate at its sole cost in compliance with all Environmental Laws and this Lease: (A) any Hazardous Material Condition caused by Tenant's or its Agents' or Invitees' Handling Hazardous Materials during the Term; and (B) any Hazardous Material Condition discovered during Tenant's occupancy that any Regulatory Agency requires to be Remediated if Remediation would not have been required but for Tenant's use of or Changes to the Premises.

(iii) If Environmental Laws governing Remediation require a remedial action plan, Tenant must provide a draft of its plan to Port for comment and approval before submittal to the appropriate Environmental Regulatory Agency, and a copy of the final plan as submitted.

(iv) In all situations relating to Handling or Remediating Hazardous Materials, Tenant must take all actions that are reasonably necessary in Port's sole judgment to protect the value of the Premises or the Facility, such as obtaining Environmental Regulatory Approvals related to Hazardous Materials and taking measures to remedy any deterioration in the condition or diminution of the value of any portion of the Premises or the Facility in any manner related directly or indirectly to Hazardous Materials.

(b) Unless Tenant or its Agents or Invitees Exacerbate the Hazardous Material Condition, Tenant will not be obligated to Remediate any Hazardous Material Condition: (i) caused solely by City, Port, or their Agents during Tenant's occupancy of the Premises; or (ii) arising before the Commencement Date or the date of Tenant's first use of the Premises, whichever is earlier.

15.5. Port's Right to Audit. Port will have the right, but not the obligation, to inspect and audit the Premises for any Hazardous Materials, including the right to Investigate, at reasonable times under Section 24 (Port's Entry on Premises). Port's failure to inspect or obtain samples or to detect conditions attributable to Tenant's operations if an inspection is conducted may not be deemed to be a release of any liability for any Hazardous Materials subsequently determined to be Tenant's responsibility under this Lease.

15.6. Notification of Asbestos. Port hereby notifies Tenant, in accordance with the OSHA Asbestos Rule (1995), 59 Fed. Reg. 40964, 29 CFR §§ 1910.1001, 1926.1101 (as amended, clarified and corrected) (OSHA Asbestos Rule); California Health and Safety Code §§ 25915-259.7 and Cal-OSHA General Industry Safety Order for Asbestos, 8 CCR § 5208, of the presence of asbestos-containing materials ("ACMs") and/or presumed asbestos-containing materials ("PACMs") (as such terms are defined in Cal-OSHA General Industry Safety Order for Asbestos), in the locations identified in the summary/table, if any, set forth in **Schedule 1** attached hereto.

This notification by Port is made pursuant to a building inspection survey(s), if any, performed by Port or its contractors qualified to perform an asbestos building survey identified in the summary/table, if any, set forth in **Schedule 1** attached hereto. Such survey(s), monitoring data and other information are kept at Port of San Francisco, Pier 1, San Francisco, California, 94111 and are available for inspection upon request.

Tenant hereby acknowledges receipt of the notification specified in the first paragraph of Section 15.6 hereof and the notice or report attached as **Schedule 1** hereto and understands, after having consulted its legal counsel, that it must make its employees and contractors aware of the presence of ACMs and/or PACMs in or about the Premises in order to avoid or minimize any damage to or disturbance of such ACMs and/or PACMs. Tenant further acknowledges its obligations under Cal-OSHA General Industry Safety Order for Asbestos to provide information to its employees and contractors regarding the presence of ACMs and PACMs at the Premises and to provide a training program for its employees that conforms with 8 CCR § 5208(j)(7)(C).

Tenant agrees that its waiver of Claims set forth in Section 19 below (Indemnity and Exculpation) is given with full knowledge of the presence, or possibility, of asbestos in or about the Premises and/or the Facility and the potential consequences of such fact. Tenant is aware that the presence, or possibility, of asbestos in or about the Premises may limit Tenant's ability to construct Alterations to the Premises without Tenant first performing abatement of such asbestos. The presence of asbestos in the Premises and/or the Facility and the removal or non-removal by Port of all or a portion of the asbestos in the Facility, whether in the Premises or elsewhere in the Facility, shall not, however, (i) entitle Tenant to any Claim, (ii) relieve Tenant of any of its obligations hereunder, including without limitation the obligation to pay Rent, or (iii) constitute or be construed as a constructive or other eviction of Tenant.

Notwithstanding any other provisions of this Lease, Tenant agrees to Indemnify Port for Tenant's acts or omissions that result in (1) asbestos-related enforcement actions, including both administrative or judicial proceedings, and (2) any Claims arising from an alleged violation of Cal-OSHA General Industry Safety Order for Asbestos and/or exposures to asbestos.

15.7. Notification of Lead. Port hereby notifies Tenant of the potential presence of lead-containing and presumed lead-containing materials in the Premises or Facility. Disturbance or removal of lead is regulated by, among other Laws, 29 CFR §§ 1910.1025, 1926.62; California Health & Safety Code §§ 105185-105197 and 105250-105257; Cal-OSHA

Construction Safety Order for Lead, Title 8 CCR § 1532.1; Title 17 CCR Chapter 8; and Port Building Code § 3424.

Tenant agrees that its waiver of Claims set forth in Section 19 below (Indemnity and Exculpation) is given with full knowledge of the presence, or possibility, of lead in or about the Premises and/or the Facility and the potential consequences of such fact. Tenant is aware that the presence, or possibility, of lead in or about the Premises may limit Tenant's ability to perform any Improvements or Alterations to the Premises without Tenant first performing abatement of such lead. The presence of lead in the Premises and/or the Facility and the removal or non-removal by Port of all or a portion of the lead, whether in the Premises or elsewhere in the Facility, shall not, however, (i) entitle Tenant to any Claim, (ii) relieve Tenant of any of its obligations hereunder, including without limitation the obligation to pay Rent, or (iii) constitute or be construed as a constructive or other eviction of Tenant. Notwithstanding any other provisions of this Lease, Tenant agrees to Indemnify Port for its acts or omissions that result in (1) lead-related enforcement actions, including both administrative or judicial proceedings, and (2) any Claims arising from an alleged violation of Cal-OSHA Construction Safety Order for Lead and/or exposures to lead.

15.8. Storm Water Pollution Prevention.

(a) Tenant must comply with the applicable provisions of the Statewide General Permit for Discharge of Industrial Storm Water issued by the State Water Resources Control Board, including filing a Notice of Intent to be covered, developing and implementing a site-specific Storm Water Pollution Prevention Plan ("SWPPP"), and conducting storm water monitoring and reporting. Tenant's SWPPP and a copy of a Notice of Intent for Tenant's Premises must be submitted to Port's Real Estate Division before beginning operations on the Premises.

(b) Post-Construction Requirements. In addition to requiring compliance with the permit requirements under Subsection (a), Tenant shall comply with the post-construction stormwater control provisions of the Statewide General Permit for Discharge of Stormwater from Small Municipalities and the San Francisco Stormwater Management Requirements and Design Guidelines, subject to review and permitting by the Port.

15.9. Presence of Hazardous Materials. California Law requires landlords to disclose to tenants the presence or potential presence of certain Hazardous Materials. Accordingly, Tenant is hereby advised that Hazardous Materials (as herein defined) may be present on or near the Premises, including, but not limited to, vehicle fluids, janitorial products, tobacco smoke, and building materials containing chemicals, such as asbestos, naturally-occurring radionuclides, lead and formaldehyde. Further, the following known Hazardous Materials are present on the property: asbestos in building, if any, as described in *Schedule 1* attached hereto, and the Hazardous Materials described in the reports listed in *Schedule 4*, copies of which have been delivered to or made available to Tenant. By execution of this Lease, Tenant acknowledges that the notice set forth in this section satisfies the requirements of California Health and Safety Code Section 25359.7 and related Laws. Tenant must disclose the information contained in this Section 15.9 to any subtenant, licensee, transferee, or assignee of Tenant's interest in this Lease. Tenant also acknowledges its own obligations pursuant to California Health and Safety Code Section 25359.7 as well as the penalties that apply for failure to meet such obligations.

15.10. Survival. Tenant's obligations under Section 15 shall survive the expiration or earlier termination of this Lease.

For purposes of this Section 15, the term "**Commencement Date**" shall mean the commencement date (including any early entry period, if any) of the Prior Lease.

16. INSURANCE.

16.1. Required Insurance Coverage. Tenant, at its sole cost and expense, shall maintain, or cause to be maintained, throughout the Term, the following insurance:

(a) **General Liability Insurance.** Comprehensive or commercial general liability insurance, with limits not less than One Million Dollars (\$1,000,000.00) each occurrence combined single limit for bodily injury and property damage, including coverages for contractual liability, independent contractors, broad form property damage, personal injury, products and completed operations, fire damage and legal liability with limits not less than Two Hundred Fifty Thousand Dollars (\$250,000.00), and explosion, collapse and underground (XCU) coverage during any period in which Tenant is conducting any activity on or Alteration or Improvement to the Premises with risk of explosion, collapse, or underground hazards. This policy must also cover non-owned and for-hire vehicles and all mobile equipment or unlicensed vehicles, such as forklifts.

(b) **Automobile Liability Insurance.** Comprehensive or business automobile liability insurance with limits not less than One Million Dollars (\$1,000,000.00) each occurrence combined single limit for bodily injury and property damage, including coverages for owned and hired vehicles and for employer's non-ownership liability, which insurance shall be required if any automobiles or any other motor vehicles are operated in connection with Tenant's activity on the Premises or the Permitted Use. If parking is a Permitted Use under this Lease, Tenant must obtain, maintain, and provide to Port upon request evidence of personal automobile liability insurance for persons parking vehicles at the Premises on a regular basis, including without limitation, Tenant's Agents and Invitees.

(c) **Workers' Compensation; Employer's Liability; Jones Act; U.S. Longshore and Harborworker's Act Insurance.** Worker's Compensation Insurance, U.S. Longshore and Harborworker's Act Insurance and Jones Act Insurance with Employer's Liability limit not less than One Million Dollars (\$1,000,000.00) for each accident, injury or illness, on employees eligible for each. In the event Tenant is self-insured for the insurance required pursuant to this Section 16.1(c), it shall furnish to Port a current Certificate of Permission to Self-Insure signed by the Department of Industrial Relations, Administration of Self-Insurance, Sacramento, California. Notwithstanding the foregoing, so long as Tenant complies with Sections 8.2(h) and 8.2(i) above, Tenant shall not be required to maintain insurance for claims under the Jones Act or U.S. Longshore and Harborworker's Act, respectively.

(d) **Personal Property Insurance.** Tenant, at its sole cost and expense, shall procure and maintain on all of Tenant's Property and Alterations, in, on, or about the Premises, personal property insurance on all risk form, excluding earthquake and flood, in an amount not less than full replacement value or a stated value, at Tenant's sole discretion, for the replacement of Tenant's Property. In addition to the foregoing, Port may, in its sole discretion, insure any personal property leased to Tenant by Port pursuant to this Lease in such amounts as Port deems reasonably appropriate and Tenant shall have no interest in the proceeds of such personal property insurance. Port shall have no responsibility or obligation to maintain insurance or replace Tenant's Property, Alterations, or any Improvements regardless of cause of loss.

(e) **Construction Activities.** At all times during any period of Tenant's construction of Improvements or Alterations subject to Section 13,

(i) Tenant shall require Tenant's contractor to maintain (a) commercial general liability insurance with limits of not less than Three Million Dollars (\$3,000,000) combined single limit for bodily injury and property damage (including personal injury and death), and products and completed operations coverage in an amount not less than Five Hundred Thousand Dollars (\$500,000) per incident, One Million Dollars (\$1,000,000) in the aggregate; (b) comprehensive automobile liability insurance with a policy limit of not less than One Million Dollars (\$1,000,000) each accident for bodily injury and property damage,

providing coverage at least as broad as the Insurance Services Office (ISO) Business Auto Coverage form covering Automobile Liability, "any auto", and insuring against all loss in connection with the ownership, maintenance and operation of automotive equipment that is owned, hired or non-owned; (c) worker's compensation with statutory limits and employer's liability insurance with limits of not less than One Hundred Thousand Dollars (\$100,000) per accident, Five Hundred Thousand Dollars (\$500,000) aggregate disease coverage and One Hundred Thousand Dollars (\$100,000) disease coverage per employee; and (d) owners and contractors protective liability with limits of not less than Three Million Dollars (\$3,000,000) combined single limit for bodily injury and property damage (including personal injury and death). Tenant shall cause Tenant's Agents (other than Tenant's contractor) to carry such insurance as shall be reasonably approved by Port taking into account the nature and scope of the work and industry custom and practice.

(ii) In addition, Tenant shall carry "**Builder's All Risk**" insurance on a form reasonably approved by Port, in the amount of one hundred percent (100%) of the completed value of all new construction, insuring all new construction, including all materials and equipment incorporated in, on or about the Premises, and in transit or storage off-site, that are or will be part of the permanent Improvements, against "**all risk**" and "special form" hazards.

(iii) Tenant shall require all providers of professional services, including architectural, design, engineering, geotechnical, and environmental professionals under contract with Tenant for any Improvements or any Alterations to maintain professional liability (errors or omissions) insurance, with limits not less than One Million Dollars (\$1,000,000.00) each claim and aggregate, with respect to all professional services provided to Tenant therefor.

(f) Other Coverage. Not more often than every year and upon not less than sixty (60) days prior written notice, Port may require Tenant to increase the insurance limits set forth above or to provide other coverage and/or different coverage amounts as may be required by Law, the City's Risk Manager or as is generally required by commercial owners of buildings similar in size, character, age and location as the Facility with respect to risks comparable to those associated with the use of the Premises.

16.2. Claims-Made Policies. If any of the insurance required in Section 16.1 above is provided under a claims-made form of policy, Tenant shall maintain such coverage continuously throughout the Term and without lapse for a period of three (3) years beyond the termination of this Lease, to the effect that should occurrences during the Term give rise to claims made after termination of this Lease, such claims shall be covered by such claims-made policies.

16.3. Annual Aggregate Limits. If any of the insurance required in Section 16.1 above is provided under a form of coverage which includes an annual aggregate limit or provides that claims investigation or legal defense costs be included in such annual aggregate limit, such annual aggregate limit shall be double the occurrence limits specified herein.

16.4. Payment of Premiums. Tenant shall pay the premiums for maintaining all required insurance.

16.5. Waiver of Subrogation Rights. Notwithstanding anything to the contrary contained herein, Port and Tenant (each a "**Waiving Party**") each hereby waives any right of recovery against the other party for any loss or damage sustained by such other party with respect to the Facility or the Premises or any portion thereof or the contents of the same or any operation therein, whether or not such loss is caused by the fault or negligence of such other party, to the extent such loss or damage is covered by insurance which is required to be purchased by the Waiving Party under this Lease or is actually covered by insurance obtained by the Waiving Party. Each Waiving Party agrees to cause its insurers to issue appropriate waiver of subrogation rights endorsements to all policies relating to the Facility or the Premises; provided, the failure to obtain any such endorsement shall not affect the above waiver.

16.6. General Insurance Matters.

(a) All liability insurance policies required to be maintained by Tenant hereunder shall contain a cross-liability clause, shall name as additional insureds by written endorsement the "**CITY AND COUNTY OF SAN FRANCISCO AND THE SAN FRANCISCO PORT COMMISSION AND THEIR OFFICERS, DIRECTORS, COMMISSIONERS, EMPLOYEES AND AGENTS,**" shall be primary and non-contributory to any other insurance available to the additional insureds with respect to claims arising under this Lease, and shall provide that such insurance applies separately to each insured against whom complaint is made or suit is brought except with respect to the limits of the company's liability.

(b) All insurance policies required to be maintained by Tenant hereunder shall be issued by an insurance company or companies reasonably acceptable to Port with an AM Best rating of not less than A-VIII and authorized to do business in the State of California. Tenant's compliance with this Section shall in no way relieve or decrease Tenant's liability under this Lease.

(c) All insurance policies required to be maintained by Tenant hereunder shall be endorsed to provide for thirty (30) days prior written notice of cancellation for any reason, intended non-renewal, or reduction in coverage to Tenant and Port.

(d) Tenant shall deliver to Port certificates of insurance, additional insured policy endorsements and waiver of subrogation endorsements in a form satisfactory to and at the direction of Port, such as hard copy documentation or use of an internet-based insurance compliance tracking systems such as EXIGIS, evidencing the coverages required herein, together with evidence of payment of premiums, on or before the Commencement Date, and upon renewal of each policy not less than thirty (30) days before expiration of the term of the policy. If Port is using an internet-based insurance compliance tracking system, Tenant's broker shall complete the insurance questionnaire and submit all required documentation. Tenant shall, upon Port's request, promptly furnish Port with a complete copy of any insurance policy required hereunder.

17. DAMAGE AND DESTRUCTION.

17.1. Damage and Destruction. If the Premises or the Facility is damaged by fire or other casualty, then Port shall repair the same provided that funds for such repairs are appropriated by Port, in its sole discretion, for such purpose and that such repairs can be made within the Repair Period. In the event such conditions are satisfied, this Lease shall remain in full force and effect except that so long as such damage or casualty is not attributable to Tenant, its Agents or Invitees, Tenant shall be entitled to a proportionate reduction of Base Rent during the Repair Period based upon the extent to which such damage and the making of such repairs materially interferes with Tenant's use or occupancy of the Premises less any insurance proceeds Tenant receives, or would have received if Tenant complied with the requirements set forth in Section 16 above, which proceeds are to be applied against the payment of Rent during any Repair Period.

Port shall use its commercially reasonable efforts to notify Tenant within ninety (90) days after the date of such damage whether or not such repairs can be made within the Repair Period, and Port's determination thereof shall be binding on Tenant. If such repairs cannot be made within the Repair Period, Port shall have the option to notify Tenant of: (a) Port's intention to repair such damage and diligently prosecute such repairs to completion within a reasonable period after the Repair Period, subject to appropriation of funds, in which event this Lease shall continue in full force and effect and the monthly Base Rent shall be reduced as provided herein; or (b) Port's election to terminate this Lease as of the date specified in such notice, which date shall be not less than thirty (30) nor more than sixty (60) days after notice is given by Port. In case of termination, the monthly Base Rent shall be reduced as provided above, and Tenant shall pay such reduced monthly Base Rent up to the date of termination.

If Port elects not to appropriate funds for such repair, Port shall give written notice to Tenant within sixty (60) days after the date Port elects not to appropriate funds of its election to terminate this Lease as of the date specified in such notice, which date shall be not less than thirty (30) nor more than sixty (60) days after notice is given by Port. In case of termination, the monthly Base Rent shall be reduced as provided above, and Tenant shall pay such reduced monthly Base Rent up to the date of termination.

If at any time during the last six (6) months of the Term, the Premises or the Facility is damaged or destroyed, then either Port or Tenant may terminate this Lease by giving written notice to the other party of its election to do so within thirty (30) days after the date of the occurrence of such damage; provided, however, Tenant may terminate only if such damage or destruction substantially impairs its use or occupancy of the Premises for the Permitted Use. The effective date of termination shall be specified in the notice of termination, which date shall not be more than thirty (30) days from the date of the notice.

Notwithstanding anything to the contrary in this Lease, (i) Port shall have no obligation to repair the Premises or the Facility, (ii) Tenant shall not be entitled to any abatement of Rent, and (iii) Tenant shall not be entitled to terminate this Lease, in the event the damage or destruction is attributable to any act or omission of Tenant, its Agents, or Invitees. In no event shall Port be required to repair any damage to Tenant's Property or any paneling, decorations, railings, floor coverings, or any Improvements or other Alterations installed or made on the Premises by or at the expense of Tenant. Notwithstanding any other provision of this Lease, in the event the Premises or the Facility is substantially damaged or destroyed and Port intends to rebuild for a Port program or project that is inconsistent with this Lease, Port may terminate this Lease upon written notice to Tenant.

17.2. Waiver. Port and Tenant intend that the provisions of Section 17 govern fully in the event of any damage or destruction and accordingly, Port and Tenant each hereby waives the provisions of Section 1932, subdivision 2, Section 1933, subdivision 4, Sections 1941 and 1942 of the Civil Code of California or under any similar Law now or hereafter in effect.

18. EMINENT DOMAIN.

18.1. General. If all or part of the Premises shall be taken by any public or quasi-public authority under the power of eminent domain or conveyance in lieu thereof, this Lease shall terminate as to any portion of the Premises so taken or conveyed on the Date of Taking.

18.2. Partial Takings. If (a) a part of the Premises shall be taken by any public or quasi-public authority under the power of eminent domain or conveyance in lieu thereof, and (b) Tenant is reasonably able to continue the operation of Tenant's business in that portion of the Premises remaining, and (c) Port elects to restore the Premises to an architectural whole, then this Lease shall remain in effect as to the portion of the Premises remaining, and the Base Rent payable from the Date of Taking shall be reduced by an amount that is in the same ratio to the Base Rent as the value of the area so taken bears to the total value of the Premises immediately before the Date of Taking. If, after a partial taking, Tenant is not reasonably able to continue the operation of its business in the Premises or Port elects not to restore the Premises to an architectural whole, this Lease may be terminated by either Port or Tenant by giving written notice to the other party no earlier than thirty (30) days prior to the Date of Taking and no later than thirty (30) days after the Date of Taking. Such notice shall specify the date of termination, which shall be not less than thirty (30) nor more than sixty (60) days after the date of notice.

18.3. Taking of the Facility. If any substantial portion of the Facility is taken under the power of eminent domain or conveyance in lieu thereof, whether any portion of the Premises is taken or not, Port shall have the right to terminate this Lease by written notice to Tenant within thirty (30) days of the Date of Taking.

18.4. Temporary Takings. Notwithstanding anything to the contrary contained in Section 18, if a taking occurs with respect to all or any part of the Premises for a limited period

of time, this Lease shall remain unaffected thereby and Tenant shall continue to pay Rent and to perform all of the terms, conditions and covenants of this Lease. Tenant shall be entitled to receive that portion of any award representing compensation for the use or occupancy of the Premises during the Term up to the total Rent owing by Tenant for the period of the taking, and Port shall be entitled to receive the balance of any award.

18.5. Award; Waiver; Termination of Lease; Rent. Upon termination of this Lease in its entirety pursuant to Section 18.3, or pursuant to an election under Section 18.2, then:

(i) Tenant's obligation to pay Rent shall continue up until the date of termination and thereafter shall cease, and (ii) Port shall be entitled to the entire Award in connection therewith (including, but not limited to, any portion of the Award made for the value of the leasehold estate created by this Lease and any Improvements Pertaining to the Realty), and Tenant shall have no claim against Port for the value of any unexpired term of this Lease, provided that Tenant may make a separate claim for compensation, and Tenant shall receive any Award made specifically to Tenant, for Tenant's relocation expenses or the interruption of or damage to Tenant's business or damage to Tenant's Property. Port and Tenant intend that the provisions of Section 18 shall govern fully in the event of condemnation and accordingly, Port and Tenant each hereby waive any right to terminate this Lease in whole or in part under Sections 1265.110, 1265.120, 1265.130, and 1265.140 of the California Code of Civil Procedure or under any similar law now or hereafter in effect.

19. INDEMNITY AND EXCULPATION.

19.1. General Indemnity. Tenant shall Indemnify Port, City, including, but not limited to, all of their respective boards, commissions, departments, agencies, and other subdivisions, and their respective Agents (collectively, "**Indemnified Parties**") from, and shall defend them, without cost to the Indemnified Parties, against any and all Claims arising directly or indirectly out of: (a) any accident, injury to or death of any person, including any Agents and/or Invitees of Tenant, or loss or damage to or destruction of any property occurring in, on or about the Premises, the Facility or any other Port property, from any cause whatsoever, or (b) any default by Tenant in the observance or performance of any of the terms, covenants or conditions of this Lease, including the provisions of Section 20, or (c) the use, occupancy, manner of use or occupancy, or condition of the Premises or the activities therein by Tenant, its Agents, or Invitees, or (d) any construction or other work undertaken by Tenant on the Premises whether before or during the Term, or (e) any acts, omissions or negligence of Tenant, its Agents or Invitees, in, on or about the Premises, the Facility or any other Port property.

19.2. Hazardous Materials Indemnity.

(a) In addition to its obligations under Section 19.1, Tenant, for itself and on behalf of its Agents and Invitees, agrees to Indemnify the Indemnified Parties from any and all Claims and Hazardous Material Claims that arise as a result of: (i) any Hazardous Material Condition, and (ii) Tenant's Exacerbation of any Hazardous Material Condition.

(b) Tenant's obligation to Indemnify the Indemnified Parties includes: (i) costs incurred in connection with any Investigation or Remediation requested by Port or required by any Environmental Regulatory Agency and to restore the affected area to its condition before the Release; (ii) damages for diminution in the value of the Premises or the Facility; (iii) damages for the loss or restriction on use of rentable or usable space or of any amenity of the Premises or the Facility; (iv) damages arising from any adverse impact on marketing the space; (v) sums paid in settlement of Claims, Hazardous Material Claims, Environmental Regulatory Actions, including fines and penalties; (vi) natural resource damages; and (vii) attorneys' fees, consultant fees, expert fees, court costs, and all other litigation, administrative or other judicial or quasi-judicial proceeding expenses. If Port pays any costs within the scope of this section, Tenant must reimburse Port for Port's costs, plus interest at the Interest Rate from the date Port incurs each cost until paid, within three (3) business days after Port's payment demand. Tenant's obligations hereunder shall survive the expiration or earlier termination of this Lease.

19.3. Scope of Indemnities. The Indemnification obligations of Tenant set forth in this Lease shall be enforceable regardless of the joint or concurrent, active or passive negligence of the Indemnified Parties, and regardless of whether liability without fault is imposed or sought to be imposed on the Indemnified Parties. The Indemnification obligations of Tenant set forth in this Lease shall be enforceable except to the extent that such Indemnity is void or otherwise unenforceable under applicable Law in effect on, or validly retroactive to, the date of this Lease. Except as specifically provided otherwise, the Indemnification obligations of Tenant set forth in this Lease shall exclude Claims resulting solely from the willful misconduct or gross negligence of the Indemnified Parties.

In addition to Tenant's obligation to Indemnify the Indemnified Parties, Tenant specifically acknowledges and agrees that it has an immediate and independent obligation to defend the Indemnified Parties from any Claim which actually or potentially falls within the Indemnification obligations of Tenant set forth in this Lease, even if the allegations are or may be groundless, false or fraudulent. This Indemnification by Tenant shall begin from the first notice that any claim or demand is or may be made and shall continue at all times thereafter.

19.4. Exculpation and Waiver. To the fullest extent permitted by law, Tenant, as a material part of the consideration to be rendered to Port, hereby waives any and all Claims, including without limitation all Claims arising from the joint or concurrent, active or passive, negligence of the Indemnified Parties, but excluding any Claims caused solely by the Indemnified Parties' willful misconduct or gross negligence. The Indemnified Parties shall not be responsible for or liable to Tenant, and Tenant hereby assumes the risk of, and waives and releases the Indemnified Parties from all Claims, whether direct or indirect, known or unknown, foreseen or unforeseen, for any injury, loss or damage to any person or property in or about the Premises by or from any cause whatsoever including, without limitation, (i) any act or omission of persons occupying adjoining premises or any part of the Facility adjacent to or connected with the Premises, (ii) theft, (iii) explosion, fire, steam, oil, electricity, water, gas or rain, pollution or contamination, (iv) stopped, leaking or defective Facility Systems, (v) Facility defects, (vi) damages to goods, wares, goodwill, merchandise, equipment or business opportunities, (vii) Claims by persons in, upon or about the Premises, the Facility or any other Port property for any cause arising at any time, (viii) alleged facts or circumstances of the process or negotiations leading to this Lease prior to the Commencement Date, (ix) inability to use all or any portion of the Premises due to sea level rise, and (x) any other acts, omissions or causes to the fullest extent permitted by law.

Tenant understands and expressly accepts and assumes the risk that any facts concerning the Claims released in this Lease might be found later to be other than or different from the facts now believed to be true, and agrees that the releases in this Lease shall remain effective. Therefore, with respect to the Claims released in this Lease, Tenant waives any rights or benefits provided by Section 1542 of the Civil Code, which reads as follows:

A GENERAL RELEASE DOES NOT EXTEND TO CLAIMS THAT THE CREDITOR OR RELEASING PARTY DOES NOT KNOW OR SUSPECT TO EXIST IN HIS OR HER FAVOR AT THE TIME OF EXECUTING THE RELEASE AND THAT, IF KNOWN BY HIM OR HER, WOULD HAVE MATERIALLY AFFECTED HIS OR HER SETTLEMENT WITH THE DEBTOR OR RELEASED PARTY.

Tenant specifically acknowledges and confirms the validity of the release made above and the fact that Tenant was represented by counsel who explained the consequences of the release at the time this Lease was made, or that Tenant had the opportunity to consult with counsel, but declined to do so.

19.5. Survival. The provisions of Section 19 shall survive the expiration or earlier termination of this Lease.

20. ASSIGNMENT AND SUBLETTING.

20.1. *Transfer to Affiliate.*

(a) Tenant may make a Transfer to an Affiliate without obtaining Port's consent, provided: (1) at the time Tenant provides Port with notice, an Event of Default, or an event that with notice or the passage of time or both would constitute an Event of Default if not cured, has occurred and remains uncured; (2) if the proposed Transferee is a successor to Tenant by purchase, such proposed Transferee shall acquire all or substantially all of the stock or assets of Tenant's business or, if such proposed Transferee is a successor to Tenant by merger, consolidation or reorganization, the continuing or surviving corporation shall own all or substantially all of the assets of Tenant; (3) such proposed Transferee must have a net worth which is at least equal to the greater of Tenant's net worth as of the Commencement Date or Tenant's net worth as of the day prior to the proposed purchase, merger, consolidation or reorganization as evidenced to Port's reasonable satisfaction; (4) such proposed Transferee operates the business in the Premises for the Permitted Use and no other purpose; and (5) Tenant gives Port written notice at least sixty (60) days prior to the effective date of the proposed Transfer and provides copies of all documentation evidencing Tenant's relationship with the Affiliate and the Transfer Agreement within five (5) days after the actual Transfer Date. A Transfer to an Affiliate that does not meet the criteria specified in this Section 20.1(a) shall be subject to Port's prior written consent under Section 20.2.

(b) Port will have the right to: (i) request additional documentation and information relating to Tenant's relationship with the Transferee for three (3) months after Tenant has delivered all documents required under Subsection (a); and (ii) object to the Transfer on the grounds that the Transferee is not an Affiliate as defined in this Lease, if written notice is delivered to Tenant within three (3) months after Port's receipt of all required and requested information.

(c) Any Transfer that does not comply with this Section fully will constitute an incurable Event of Default and will be void as to Port and this Lease.

20.2. *Transfer to Non-Affiliate.*

(a) Except for a Transfer to an Affiliate meeting the requirements of Section 20.1, Tenant must obtain Port's prior written consent to any Transfer, which Port will not withhold unreasonably.

(i) Tenant agrees that any of the following will be a reasonable basis for Port to withhold its consent: (1) at the time Tenant requests Port's consent, an Event of Default, or an event that with notice or the passage of time or both would constitute an Event of Default if not cured, has occurred and remains uncured; (2) the Transfer is an Assignment or a Sublease by a Transferee of Tenant; (3) the Transferee's financial condition is or may become insufficient to support all of the financial and other obligations of this Lease; (4) the Transferee's intended use of the Premises is inconsistent with this Lease or otherwise will affect any City or Port interest materially and adversely; (5) the nature of the Transferee's use of the Premises would involve an increased risk of the Handling or Release of Hazardous Materials or of fire or other casualty; (6) the business reputation or character of the Transferee or any of its Affiliates is not reasonably acceptable to Port; or (7) the Transferee is not likely to conduct a business in the Premises of a quality substantially equal to Tenant's or otherwise reasonably acceptable to Port.

(ii) Tenant also agrees that Port will have the right to impose reasonable conditions to a requested consent to a Transfer, which may include: (1) requiring the Transferee to assume all of Tenant's obligations under this Lease; and (2) giving Port the right to terminate without notice all of Tenant's then-existing Subleases if this Lease is terminated before the existing Subleases expire.

(b) At least sixty (60) days before any Transfer to a Non-Affiliate, Tenant must give Port a Transfer Notice and the following: (i) financial statements for the three (3) years before the Transfer Date (or each year of the proposed Transferee's existence, if shorter) for the Transferee and for any other Person who will be liable for Tenant's obligations under this Lease; (ii) Tenant's current financial statements; (iii) a copy of the proposed Transfer Agreement; and (iii) the Transferee's completed pre-screening and leasing application. In addition, Tenant must provide: (1) any other information, documentation, or evidence that Port requests to enable Port to evaluate the Transfer and the Transferee; and (2) if any of the Transfer Terms are modified before the Transfer Date, a new Transfer Notice and all relevant documentation for any modified Transfer Terms. Tenant's Transfer Notice will not be complete until Tenant has provided Port with all information required under this Subsection.

For up to thirty (30) days after receipt of the complete Transfer Notice, Port will have the right to: (1) terminate this Lease as of the proposed Transfer Date; (2) sublease or take an assignment from Tenant of the interest that Tenant proposes to Transfer, on the same terms and conditions as stated in the Transfer Agreement; and (3) negotiate and contract directly with the Transferee on terms acceptable to Port in its sole and absolute discretion.

(c) If Port consents to the Transfer, Tenant must close the Transfer on the Transfer Terms stated in the Transfer Notice within ninety (90) days after Port notifies Tenant of Port's consent. If the Transfer Agreement does not close within the 90-day period, then Port's consent will expire, unless Tenant gives Port a new Transfer Notice, in which case Port again will be entitled to exercise any of the options under this Section.

(d) Any Transfer that does not comply with this Section fully will constitute an incurable Event of Default and will be void as to Port and this Lease. Port's consent to one Transfer will have no effect with respect to any other Transfer.

(e) Tenant agrees to reimburse Port for all costs, including attorneys' fees, that Port incurs to review, investigate, process, document, disapprove, or approve any Transfer request.

20.3. Sublease. In addition to all requirements in Section 20.2, the following provisions apply to any Transfer in the form of a Sublease.

(a) Until the occurrence of an Event of Default, Tenant will have the right to receive and collect rents from the Sublease. The Sublease must require the Transferee to pay the rent and other sums due under the Sublease directly to Port upon receiving Port's written notice that Tenant is in default under this Lease, a copy of which Port will deliver to Tenant. Tenant agrees that it will hold in trust for Port's benefit any Sublease rent or other sums that Tenant collects from the Transferee after Port's notice to the Transferee, and Tenant will be obligated to forward the same to Port immediately upon receipt. Port's collection of rents and other sums under this Section will not constitute Port's acceptance of attornment by the Transferee.

(b) Tenant agrees to pay to Port immediately upon receipt all Excess Rent, less Subletting Expenses, as Additional Rent. In calculating Excess Rent, Subletting Expenses will be amortized on a straight-line basis over the term of the Sublease, without interest. For example, if: (i) the term of the Sublease is 5 years; (ii) Sublease rent is \$5,000 per month; (iii) Tenant's concurrent Rent payable for the Sublease premises is \$3,000 per month; (iv) Tenant's Subletting Expenses are \$15,000 in brokerage commissions and \$15,000 for new tenant improvements for the Sublease premises, then the amount of Excess Rent Tenant must pay to Port in connection with the Sublease is \$1,500 per month, as shown in the calculation below.

Term of Sublease: 5 years x 12 months = 60 months

Subletting Expenses: \$15,000 + \$15,000 = \$30,000

Amortized Subletting Expenses:	\$30,000/60 months = \$500/month
Excess Rent:	\$5,000/month - \$3,000/month = \$2,000/month
Additional Rent:	\$2,000/month - \$500/month = \$1,500/month

20.4. Transfer Agreement Requirements. Any Transfer Agreement must include the provisions set forth below.

(a) The Transferee's express assumption of, and acknowledgement and agreement that the Transferee will be jointly and severally liable for, all of Tenant's obligations under this Lease;

(b) The Indemnification clause and waiver of claims provisions in Section 19 (Indemnity and Exculpation);

(c) Insurance provisions requiring that all of the Transferee's liability and other insurance policies name "The City and County of San Francisco, the San Francisco Port Commission, and their officers, commissioners, agents, employees, and representatives" as additional insureds and acknowledging Port's right to demand increased coverage to amounts customarily required by other San Francisco landlords for premises where business activities similar to the Transferee's are conducted;

(d) A provision stating that if this Lease is terminated for any reason, the Transferee's right to possession under the Transfer Agreement will terminate;

(e) A provision under which the Transferee expressly waives any and all relocation assistance and benefits in connection with this Lease to the extent permitted by applicable Laws; and

(f) A provision under which the Transferee expressly agrees to report the transfer to the County Assessor in accordance with Section 6.2 of this Lease.

20.5. Notice to Port. In addition to the obligations under Section 6.2, within thirty (30) days of entering into any agreement under which Tenant grants any person the right to occupy or use any portion of the Premises for any period of time, including without limitation, any assignment, sublease, license, permit, concession or vendor agreement or other agreement or renewal thereof, Tenant shall provide written notice to Port and Assessor and a copy of such agreement, regardless of whether Port consent is required under this Lease for such agreement. Tenant agrees to provide such further information as may be requested by City or Port to enable compliance with reporting obligations under state Law and San Francisco Administration Code Sections 23.38 and 23.39 (or any successor ordinance).

20.6. Transfer Audit. Tenant agrees to make its Books and Records available to, and cooperate with, any Port representative for the purpose of conducting an audit of the accuracy of Tenant's financial reporting on the Transfer until the later of (i) four (4) years after the end of each Lease Year to which such records apply or, (ii) if an audit is commenced or if a controversy should arise between the parties as to the accuracy of Tenant's financial reporting on the Transfer, until such audit or controversy is concluded. If an audit reveals that Tenant has overstated Subletting Expenses or any other costs in connection with a Transfer, Tenant must pay Port promptly upon demand the difference between the amount Tenant deducted and the amount it should have deducted, plus interest at the Interest Rate from the Transfer Date until paid. As used in this section, Tenant includes Affiliates where applicable.

20.7. Acknowledgement. Tenant acknowledges and agrees that Port's rights with respect to Transfers are reasonable limitations for purposes of California Civil Code Section 1951.4 and waives any Claims arising from Port's actions under this Section 20.

20.8. *Transfer Definitions.* For the purpose of this Section, references to this Lease and the Premises mean this Lease and the Premises to the extent Tenant's leasehold interest is affected by a Transfer. Other applicable definitions are in Section 2.

21. DEFAULT BY TENANT.

Any of the following shall constitute an event of default (the "**Event of Default**") by Tenant hereunder:

(a) failure to pay to Port any Rent or other sum payable hereunder when due, and such default continues for a period of three (3) days following written notice from Port. Notwithstanding the foregoing, Port shall not be required to provide such notice more than twice during any 12-month period, and any such failure by Tenant after Tenant has received two (2) such notices in such 12-month period shall constitute an Event of Default by Tenant hereunder without any further action by Port or opportunity of Tenant to cure except as may be required by Section 1161 of the California Code of Civil Procedure; or

(b) abandonment or vacation of the Premises by Tenant; or

(c) failure to use the Premises solely for the Permitted Use, as determined by Port in its sole and absolute discretion and such failure continues for a period of twenty-four (24) hours following written notice from Port; provided, however, that notwithstanding the foregoing, failure to use the Premises solely for the Permitted Use shall, at Port's sole and absolute discretion, be deemed an incurable breach of this Lease, allowing Port to immediately terminate this Lease upon written notice without an opportunity to cure; or

(d) failure by Tenant to execute and deliver to Port the estoppel certificate within the time period and in the manner required by Section 32 below, and Tenant's failure to cure the foregoing default within five (5) days following written notice from Port; or

(e) a Transfer, or attempted Transfer, of this Lease or the Premises by Tenant contrary to the provisions of Section 20 above; or

(f) failure by Tenant or Tenant's broker as applicable to provide evidence of insurance coverage complying with the provisions of Section 16 above, failure to maintain any insurance required to be maintained by Tenant pursuant to this Lease, or if any such insurance shall be canceled or terminated or shall expire or be reduced or materially changed, except as permitted in this Lease, and Tenant's or Tenant's broker's failure to deliver evidence of such coverage or failure to reinstate such coverage, all within three (3) business days following written notice from Port; or

(g) failure by Tenant to comply with the provisions of Section 15 above and Tenant's failure to cure the foregoing default within twenty-four (24) hours following written notice from Port. If such default cannot reasonably be cured within such twenty-four (24) hour period, Tenant shall not be in default of this Lease if Tenant commences to cure the default within such twenty-four (24) hour period and diligently and in good faith continues to cure the default, provided, however, in no event shall Tenant have more than thirty (30) days to cure such default; or

(h) failure by Tenant to discharge any lien or encumbrance placed on the Facility or any part thereof in violation of this Lease within ten (10) days after the date such lien or encumbrance is filed or recorded against the Facility or any part thereof, or if Tenant has no knowledge of such lien, then Tenant shall discharge such lien or encumbrance within fifteen (15) days following Tenant's knowledge of such lien or encumbrance; or

(i) failure by Tenant to observe, keep or perform any of the other terms, covenants, agreements or conditions contained in this Lease and required to be observed or performed by Tenant and not specifically enumerated in this Section 21, and such failure continues for a period of fifteen (15) days after written notice by Port, provided that if such

default is not capable of cure within such fifteen (15) day period, Tenant shall have a reasonable period to complete such cure if Tenant promptly undertakes action to cure such default within such fifteen (15) day period and thereafter diligently prosecutes the same to completion within sixty (60) days after the receipt of notice of default from Port. Port shall not be required to provide such notice more than twice in any twelve (12) month period with respect to any material non-monetary defaults and after the second notice in any calendar year, any subsequent failure by Tenant during such twelve (12) month period shall automatically constitute an Event of Default hereunder; or

(j) Tenant shall become bankrupt or insolvent or make a transfer in fraud of creditors, or make an assignment for the benefit of creditors, or bring or have brought against Tenant any action or proceedings of any kind under any provision of the U.S. Bankruptcy Code or under any other insolvency, bankruptcy or reorganization act and, in the event such proceedings are involuntary, Tenant is not discharged from the same within sixty (60) days thereafter; or

(k) a receiver is appointed for a substantial part of the assets of Tenant and such receiver is not discharged within sixty (60) days; or

(l) this Lease or any estate of Tenant under this Lease shall be levied upon by any attachment or execution and such attachment is not stayed or lifted within sixty (60) days; or

(m) An uncured default by Tenant under the terms of Lease L-16612 dated May 29, 2020, as amended by that First Amendment to Lease dated October 3, 2022, Lease L-16611 dated as of May 29, 2020, as amended by that First Amendment to Lease dated October 3, 2022, and/or Lease L-16711 dated as of January 21, 2021, as amended by that First Amendment to Lease dated October 3, 2022; or

(n) without limiting the provisions of Sections 21(c) or 21(g) above or lengthening the cure periods under those subsections, failure by Tenant to comply with Laws and Tenant's failure to cure the foregoing default within forty-eight (48) hours following written notice from Port.

22. PORT'S REMEDIES.

Upon default by Tenant, Port shall, without further notice or demand of any kind to Tenant or to any other person, have the following remedies:

22.1. *Tenant's Right to Possession Not Terminated.* Port has the remedy described in Section 1951.4 of the California Civil Code (a landlord may continue the lease in effect after a tenant's breach and abandonment and recover rent as it becomes due, if the tenant has the right to sublet and assign subject only to reasonable limitations) under which it may continue this Lease in full force and effect and Port may enforce all of its rights and remedies under this Lease, including the right to collect Rent when due. During the period Tenant is in default, Port may enter the Premises without terminating this Lease and relet them, or any part of them, to third parties for Tenant's account. Tenant shall be liable immediately to Port for all reasonable costs Port incurs in reletting the Premises, including, but not limited to, broker's commissions, expenses of remodeling the Premises required by the reletting and like costs. Reletting can be for a period shorter or longer than the remaining Term, at such rents and on such other terms and conditions as Port deems advisable. Tenant shall pay to Port the Rent due under this Lease on the dates the Rent is due, less the Rent Port receives from any reletting. In the event that Port shall elect to so relet, then rentals received by Port from such reletting shall be applied in the following order: (i) to reasonable attorneys' fees incurred by Port as a result of a default and costs in the event suit is filed by Port to enforce such remedies; (ii) to the payment of any indebtedness other than Rent due hereunder from Tenant to Port; (iii) to the payment of any costs of maintaining, preserving, altering, repairing and preparing the Premises for reletting, the other costs of reletting, including but not limited to brokers' commissions, attorneys' fees and expenses of removal of Tenant's Personal Property, trade fixtures and Alterations; (iv) to the payment of

Rent due and unpaid hereunder; (v) to the payment of future Rent and other sums payable by Tenant hereunder as the same may become due and payable hereunder; and (vi) the balance, if any, shall be paid to Tenant upon (but not before) expiration of the Term. Should that portion of such rentals received from such reletting during any month, which is applied to the payment of Rent hereunder, be less than the Rent payable during the month by Tenant hereunder, then Tenant shall pay such deficiency to Port. Such deficiency shall be calculated and paid monthly. No act by Port allowed by this Section 22.1 shall terminate this Lease unless Port notifies Tenant that Port elects to terminate this Lease. After Tenant's default and for as long as Port does not terminate Tenant's right to possession of the Premises, if Tenant obtains Port's consent Tenant shall have the right to assign or sublet its interest in this Lease, but Tenant shall not be released from liability.

22.2. Termination of Tenant's Right to Possession. Port may terminate Tenant's right to possession of the Premises at any time. No act by Port other than giving notice of termination to Tenant shall terminate this Lease. Acts of maintenance, efforts to relet the Premises, or the appointment of a receiver on Port's initiative to protect Port's interest under this Lease shall not constitute a termination of Tenant's right to possession. If Port elects to terminate this Lease, Port has the rights and remedies provided by California Civil Code Section 1951.2, including the right to recover from Tenant the following.

(a) The worth at the time of award of the unpaid Rent which had been earned at the time of termination; plus

(b) The worth at the time of award of the amount by which the unpaid Rent which would have been earned after termination until the time of award exceeds the amount of such rental loss that Tenant proves could have been reasonably avoided; plus

(c) The worth at the time of award of the amount by which the unpaid Rent for the balance of the Term after the time of award exceeds the amount of the loss of Rent that Tenant proves could be reasonably avoided; plus

(d) Any other amounts necessary to compensate Port for the detriment proximately caused by Tenant's default, or which, in the ordinary course of events, would likely result, including, but not limited to, attorneys' fees and court costs, the costs of carrying the Premises such as repairs, maintenance, taxes and insurance premiums, utilities, security precautions and the reasonable costs and expenses incurred by Port in (i) retaking possession of the Premises; (ii) cleaning and making repairs and alterations necessary to return the Premises to good condition and preparing the Premises for reletting; (iii) removing, transporting and storing any of Tenant's Property left at the Premises (although Port shall have no obligation so to do); and (iv) reletting the Premises, including, without limitation, brokerage commissions, advertising costs and attorneys' fees. Efforts by Port to mitigate the damages caused by Tenant's breach of this Lease do not waive Port's rights to recover damages upon termination.

The "**worth at the time of award**" of the amounts referred to in Sections 22.2(a) and 22.2(b) above shall be computed by allowing interest at an annual rate equal to the lesser of the Interest Rate or the maximum non-usurious rate Port is permitted by Law to charge. The "**worth at the time of award**" of the amount referred to in Section 22.2(c) above shall be computed by discounting the amount at the discount rate of the Federal Reserve Bank of San Francisco at the time of award, plus one percent (1%).

22.3. Appointment of Receiver. If Tenant is in default of this Lease, Port shall have the right to have a receiver appointed to collect Rent and conduct Tenant's business. Neither the filing of a petition for the appointment of a receiver nor the appointment itself shall constitute an election by Port to terminate this Lease.

22.4. Port's Right to Cure Tenant's Default. Port, at any time after Tenant commits a default, may, at Port's sole option, cure the default at Tenant's cost. If Port at any time, by reason of Tenant's default, undertakes any act to cure or attempt to cure such default that requires the

payment of any sums, or otherwise incurs any costs, damages, or liabilities (including without limitation, attorneys' fees), all such sums, costs, damages or liabilities paid by Port shall be due immediately from Tenant to Port at the time the sum is paid, and if paid by Tenant at a later date shall bear interest at the lesser of the Interest Rate or the maximum non-usurious rate Port is permitted by Law to charge from the date such sum is paid by Port until Port is reimbursed by Tenant.

22.5. *No Accord and Satisfaction.* No payment by Tenant or receipt by Port of an amount less than the Rent due under this Lease shall be deemed to be other than "on account" of the earliest Rent due; nor shall any endorsement or statement on any check or payment, or letter accompanying such check or payment, be deemed an accord and satisfaction. Port may accept any such partial payment or tender without prejudice to its right to recover the balance of any amount due and to pursue any other remedy herein provided at Law or in equity.

22.6. *Waiver of Redemption.* Tenant hereby waives, for itself and all persons claiming by and under Tenant, redemption or relief from forfeiture under California Code of Civil Procedure Sections 1174 and 1179, or under any other pertinent present or future Law, in the event Tenant is evicted or Port takes possession of the Premises by reason of any default of Tenant hereunder.

22.7. *Habitual Late Payer.* In the event Tenant is deemed to be a Habitual Late Payer, in addition to any other remedies available to Port, Port may require that Tenant enter into direct electronic payment arrangements and/or Port may require payments of Rent be made in advance on a quarterly basis.

22.8. *Remedies Not Exclusive.* The remedies set forth in Section 22 are not exclusive; they are cumulative and in addition to any and all other rights or remedies of Port now or later allowed by Law or in equity. Tenant's obligations hereunder shall survive any termination of this Lease.

23. LITIGATION EXPENSES; ATTORNEYS' FEES.

23.1. *Litigation Expenses.* The Prevailing party in any action or proceeding (including any cross-complaint, counterclaim, or bankruptcy proceeding) against the other party by reason of a claimed default, or otherwise arising out of a party's performance or alleged non-performance under this Lease, shall be entitled to recover from the other party its costs and expenses of suit, including but not limited to reasonable attorneys' fees, which shall be payable whether or not such action is prosecuted to judgment. "**Prevailing party**" within the meaning of this Section shall include, without limitation, a party who substantially obtains or defeats, as the case may be, the relief sought in the action, whether by compromise, settlement, judgment or the abandonment by the other party of its claim or defense.

23.2. *Appeals.* Attorneys' fees under this Section shall include attorneys' fees and all other reasonable costs and expenses incurred in connection with any appeal.

23.3. *City Attorney.* For purposes of this Lease, reasonable fees of attorneys of the City's Office of the City Attorney shall be based on the fees regularly charged by private attorneys with an equivalent number of years of professional experience (calculated by reference to earliest year of admission to the Bar of any State) who practice in San Francisco in law firms with approximately the same number of attorneys as employed by the Office of the City Attorney.

24. PORT'S ENTRY ON PREMISES.

24.1. *Entry for Inspection.* Port and its authorized Agents shall have the right to enter the Premises without notice at any time during normal business hours of generally recognized business days, provided that Tenant or Tenant's Agents are present on the Premises (except in the event of an emergency), for the purpose of inspecting the Premises to determine whether the

Premises is in good condition and whether Tenant is complying with its obligations under this Lease.

24.2. General Entry. In addition to its rights pursuant to Section 24.1 above, Port and its authorized Agents shall have the right to enter the Premises at all reasonable times and upon reasonable notice for any of the following purposes:

(a) To perform any necessary maintenance, repairs or restoration to the Premises or the Seawall, or to perform any services which Port has the right or obligation to perform;

(b) To serve, post, or keep posted any notices required or allowed under the provisions of this Lease;

(c) To post "For Sale" signs at any time during the Term; to post "For Lease" signs during the last six (6) months of the Term or during any period in which Tenant is in default;

(d) On an occasional basis, at all reasonable times after giving Tenant reasonable advance written or oral notice, to show the Premises to prospective tenants or other interested parties;

(e) If any excavation or other construction is undertaken or is about to be undertaken on any property or street adjacent to the Premises, to shore the foundations, footings or walls of the Premises and to erect scaffolding and protective barricades around and about the Premises as reasonably necessary in connection with such activities (but not so as to prevent or unreasonably restrict entry to the Premises), and to do any other act or thing necessary for the safety or preservation of the Premises during such excavation or other construction; or

(f) To obtain environmental samples and perform equipment and facility testing.

24.3. Emergency Entry. Port may enter the Premises at any time, without notice, in the event of an emergency. Port shall have the right to use any and all means which Port may deem proper in such an emergency in order to obtain entry to the Premises. Entry to the Premises by any of these means, or otherwise, shall not under any circumstances be construed or deemed to be a forcible or unlawful entry into, or a detainer of, the Premises, or an eviction of Tenant from the Premises or any portion of the Premises.

24.4. No Liability. Port shall not be liable in any manner, and Tenant hereby waives any Claim for damages, for any inconvenience, disturbance, loss of business, nuisance, or other damage, including without limitation any abatement or reduction in Rent, arising out of Port's entry onto the Premises as provided in Section 24 or performance of any necessary or required work on the Premises, or on account of bringing necessary materials, supplies and equipment into or through the Premises during the course thereof, except damage resulting solely from the willful misconduct or gross negligence of Port or its authorized representatives.

24.5. Nondisturbance. Port shall use its commercially reasonable efforts to conduct its activities on the Premises as allowed in Section 24 in a manner which, to the extent reasonably practicable, will minimize annoyance or disturbance to Tenant.

25. SURRENDER AND QUITCLAIM.

25.1. Surrender. Upon expiration or earlier termination of this Lease, Tenant shall surrender to Port the Premises in good order, condition, and repair (except for ordinary wear and tear occurring after the last necessary maintenance made by Tenant and except for destruction or condemnation as described in Sections 17 and 18 hereof). Ordinary wear and tear shall not include any damage or deterioration that would have been prevented by proper maintenance by Tenant, or Tenant otherwise performing all of its obligations under this Lease. The Premises shall be surrendered clean, free of debris, waste, and Hazardous Materials, and free and clear of all liens and encumbrances other than liens and encumbrances existing as of the date of this Lease and any other encumbrances created by Port. On or before the expiration or earlier termination of this Lease, Tenant at its sole cost shall remove from the Premises, and repair any

damage caused by removal of, Tenant's Property, including any signage and Alterations and Improvements specified in Port's Notice of Removal. Except for those designated in Port's Notice of Removal, Alterations and Improvements shall remain in the Premises as Port property.

If the Premises is not surrendered at the end of the Term or sooner termination of this Lease, and in accordance with the provisions of this Section 25 and Section 13.4, Tenant shall continue to be responsible for the payment of Rent (as the same may be increased pursuant to Section 26.2 or 26.3 below as applicable) until the Premises is surrendered in accordance with these Sections, and Tenant shall Indemnify Port from and against any and all loss or liability resulting from delay by Tenant in so surrendering the Premises including, without limitation, any costs of Port to obtain possession of the Premises; any loss or liability resulting from any Claim against Port made by any succeeding tenant or prospective tenant founded on or resulting from such delay and losses to Port due to lost opportunities to lease any portion of the Premises to any such succeeding tenant or prospective tenant, together with, in each instance, reasonable attorneys' fees and costs.

No act or conduct of Port, including, but not limited to, the acceptance of the keys to the Premises, shall constitute an acceptance of the surrender of the Premises by Tenant before the expiration of the Term. Only a written notice from Port to Tenant confirming termination of this Lease and surrender of the Premises by Tenant shall constitute acceptance of the surrender of the Premises and accomplish a termination of this Lease.

25.2. *Quitclaim.* Upon the expiration or earlier termination of this Lease, the Premises shall automatically, and without further act or conveyance on the part of Tenant or Port, become the property of Port, free and clear of all liens and without payment therefore by Port and shall be surrendered to Port upon such date. Upon or at any time after the expiration or earlier termination of this Lease, if requested by Port, Tenant shall promptly deliver to Port, without charge, a quitclaim deed to the Premises and any other instrument reasonably requested by Port to evidence or otherwise effect the termination of Tenant's leasehold estate hereunder and to effect such transfer or vesting of title to the Premises or any portion that Port agrees are to remain part of the Premises.

25.3. *Abandoned Property.* Any items, including Tenant's Property, not removed by Tenant as required herein shall be deemed abandoned. Port may retain, store, remove, and sell or otherwise dispose of abandoned Tenant's Property, and Tenant waives all Claims against Port for any damages resulting from Port's retention, removal and disposition of such property; provided, however, that Tenant shall be liable to Port for all costs incurred in storing, removing and disposing of abandoned Tenant's Property and repairing any damage to the Premises or the Facility resulting from such removal. Tenant agrees that Port may elect to sell abandoned Tenant's Property and offset against the sales proceeds Port's storage, removal, and disposition costs without notice to Tenant or otherwise according to the procedures set forth in California Civil Code Section 1993 et seq., the benefits of which Tenant waives.

25.4. *Survival.* Tenant's obligation under this Section 25 shall survive the expiration or earlier termination of this Lease.

26. HOLDING OVER.

26.1. *Terms of Holdover Tenancy.* Any holding over after the expiration of the Term shall not constitute a renewal of this Lease, but shall be deemed a month-to-month tenancy upon the terms, conditions, and covenants of this Lease, except as provided in this Section. Either party may cancel the month-to-month tenancy upon thirty (30) days written notice to the other party. Tenant shall Indemnify Port from and against any and all loss or liability resulting from Tenant's delay in surrendering the Premises including, without limitation, any loss or liability resulting from any claim against Port made by any succeeding tenant or prospective tenant founded on or resulting from such delay and losses to Port due to lost opportunities to lease any

portion of the Premises to any such succeeding tenant or prospective tenant, together with, in each case, actual attorneys' fees and costs.

26.2. *With Consent.* If Tenant holds over with the prior written consent of Port, monthly Base Rent shall be equal to one hundred fifty percent (150%) of the monthly Base Rent payable in the month immediately preceding the expiration of this Lease; provided that if both Tenant and Port desire to enter into a new lease or extend the existing term of this Lease but have not yet executed such new lease or extension solely due to Port's delay to produce such document, then the monthly Base Rent during such holdover period shall be equal to the higher of: (a) the Base Rent payable in the month immediately preceding the expiration of this Lease, or (b) the then current rate for the Facility approved by the Port Commission, together with any monthly charge of Additional Rent payable under this Lease.

26.3. *Without Consent.* If Tenant holds over without the prior written consent of Port, monthly Base Rent shall equal two hundred percent (200%) of the monthly Base Rent payable in the month immediately preceding the expiration of this Lease.

27. MINERAL RESERVATION.

The State of California ("**State**"), pursuant to Section 2 of Chapter 1333 of the Statutes of 1968, as amended, has reserved all subsurface mineral deposits, including oil and gas deposits, on or underlying the Premises and Tenant acknowledges such reserved rights including necessary ingress and egress rights. In no event shall Port be liable to Tenant for any Claims arising from the State's exercise of its rights nor shall such action entitle Tenant to any abatement or diminution of Rent or otherwise relieve Tenant from any of its obligations under this Lease.

28. CITY AND PORT REQUIREMENTS.

The San Francisco Municipal Codes (available at www.sfgov.org) and City and Port policies described or referenced in this Lease are incorporated by reference as though fully set forth in this Lease. The descriptions below are not comprehensive but are provided for notice purposes only; Tenant is charged with full knowledge of each such ordinance and policy and any related implementing regulations as they may be amended from time to time. Tenant understands and agrees that its failure to comply with any provision of this Lease relating to any such code provision shall be deemed a material breach of this Lease and may give rise to penalties under the applicable ordinance. Capitalized or highlighted terms used in this Section and not defined in this Lease shall have the meanings ascribed to them in the cited ordinance.

28.1. *Nondiscrimination.*

(a) Covenant Not to Discriminate. In the performance of this Lease, Tenant covenants and agrees not to discriminate on the basis of the fact or perception of a person's race, color, creed, religion, national origin, ancestry, age, sex, sexual orientation, gender identity, domestic partner status, marital status, disability or Acquired Immune Deficiency Syndrome or HIV status (AIDS/HIV status), weight, height, association with members of classes protected under Chapter 12B or 12C of the San Francisco Administrative Code or in retaliation for opposition to any practices forbidden under Chapter 12B or 12C of the Administrative Code against any employee of Tenant, any City and County employee working with Tenant, any applicant for employment with Tenant, or any person seeking accommodations, advantages, facilities, privileges, services, or membership in all business, social, or other establishments or organizations operated by Tenant in the City and County of San Francisco.

(b) Subleases and Other Contracts. Tenant shall include in all subleases and other contracts relating to the Premises a non-discrimination clause applicable to such subtenant or other contractor in substantially the form of Section 28.1(a) above. In addition, Tenant shall incorporate by reference in all subleases and other contracts the provisions of Sections 12B.2 (a),

12B.2 (c)-(k) and 12C.3 of the Administrative Code and shall require all subtenants and other contractors to comply with such provisions.

(c) **Nondiscrimination in Benefits.** Tenant does not as of the date of this Lease and will not during the Term, in any of its operations in San Francisco or where the work is being performed for the City, discriminate in the provision of bereavement leave, family medical leave, health benefits, membership or membership discounts, moving expenses, pension and retirement benefits or travel benefits (collectively "**Core Benefits**") as well as any benefits other than the Core Benefits between employees with domestic partners and employees with spouses, and/or between the domestic partners and spouses of such employees, where the domestic partnership has been registered with a governmental entity pursuant to state or local Law authorizing such registration, subject to the conditions set forth in Section 12B.2 of the Administrative Code.

(d) **CMD Form.** On or prior to the Lease Commencement Date, Tenant shall execute and deliver to Port the "Nondiscrimination in Contracts and Benefits" form approved by the CMD.

(e) **Penalties.** Tenant understands that pursuant to Section 12B.2(h) of the Administrative Code, a penalty of \$50.00 for each person for each calendar day during which such person was discriminated against in violation of the provisions of this Lease may be assessed against Tenant and/or deducted from any payments due Tenant.

28.2. Requiring Health Benefits for Covered Employees. Unless exempt, Tenant agrees to comply fully with and be bound by all of the provisions of the Health Care Accountability Ordinance (HCAO), as set forth in Administrative Code Chapter 12Q (Chapter 12Q).

(a) For each Covered Employee Tenant shall provide the appropriate health benefit set forth in Section 12Q.3 of the HCAO.

(b) Notwithstanding the above, if Tenant meets the requirements of a "small business" by the City pursuant to Section 12Q.3(e) of the HCAO, it shall have no obligation to comply with Section 28.2(a) above.

(c) If, within 30 days after receiving written notice of a breach of this Lease for violating the HCAO, Tenant fails to cure such breach or, if such breach cannot reasonably be cured within such 30-day period, Tenant fails to commence efforts to cure within such period, or thereafter fails to diligently pursue such cure to completion, the City shall have the remedies set forth in Section 12Q.5(f). Each of these remedies shall be exercisable individually or in combination with any other rights or remedies available to the City.

(d) Any Sublease or Contract regarding services to be performed on the Premises entered into by Tenant shall require the Subtenant or Contractor and Subcontractors, as applicable, to comply with the requirements of the HCAO and shall contain contractual obligations substantially the same as those set forth in Chapter 12Q of the Administrative Code. Tenant shall notify the Office of Labor Standards Enforcement ("**OLSE**") when it enters into such a Sublease or Contract and shall certify to OLSE that it has notified the Subtenant or Contractor of the obligations under the HCAO and has imposed the requirements of the HCAO on the Subtenant or Contractor through written agreement with such Subtenant or Contractor. Tenant shall be responsible for ensuring compliance with the HCAO for each Subtenant, Contractor and Subcontractor performing services on the Premises. If any Subtenant, Contractor or Subcontractor fails to comply, the City may pursue the remedies set forth in Section 12Q.5 of the Administrative Code against Tenant based on the Subtenant's, Contractor's, or Subcontractor's failure to comply, provided that OLSE has first provided Tenant with notice and an opportunity to cure the violation.

(e) Tenant shall not discharge, reprimand, penalize, reduce the compensation of, or otherwise discriminate against, any employee for notifying the City of any issue relating to the HCAO, for opposing any practice proscribed by the HCAO, for participating in any proceedings related to the HCAO, or for seeking to assert or enforce any rights under the HCAO by any lawful means.

(f) Tenant represents and warrants that it is not an entity that was set up, or is being used, for the purpose of evading the requirements of the HCAO.

(g) Tenant shall keep itself informed of the requirements of the HCAO, as they may change from time to time.

(h) Upon request, Tenant shall provide reports to the City in accordance with any reporting standards promulgated by the City under the HCAO, including reports on Subtenants, Contractors, and Subcontractors.

(i) Within ten (10) business days of any request, Tenant shall provide the City with access to pertinent records relating to any Tenant's compliance with the HCAO. In addition, the City and its agents may conduct random audits of Tenant at any time during the Term. Tenant agrees to cooperate with City in connection with any such audit.

(j) If a Contractor or Subcontractor is exempt from the HCAO because the amount payable to such Contractor or Subcontractor under all of its contracts with the City or relating to City-owned property is less than \$25,000.00 (or \$50,000.00 for nonprofits) in that fiscal year, but such Contractor or Subcontractor later enters into one or more agreements with the City or relating to City-owned property that cause the payments to such Contractor or Subcontractor to equal or exceed \$75,000.00 in that fiscal year, then all of the Contractor's or Subcontractor's contracts with the City and relating to City-owned property shall be thereafter subject to the HCAO. This obligation arises on the effective date of the agreement that causes the cumulative amount of agreements to equal or exceed \$75,000.00 in the fiscal year.

28.3. First Source Hiring. The City has adopted a First Source Hiring Program (San Francisco Administrative Code Sections 83.1 et seq.) which establishes specific requirements, procedures and monitoring for first source hiring of qualified economically disadvantaged individuals for entry-level positions as those terms are defined by the ordinance. Tenant acknowledges receiving and reviewing the First Source Hiring Program materials and requirements and agrees to comply with all requirements of the ordinance as implemented by Port and/or City, including without limitation, notification of vacancies throughout the Term and entering into a First Source Hiring Agreement, if applicable. Tenant acknowledges and agrees that it may be subject to monetary penalties for failure to comply with the ordinance or a First Source Hiring Agreement and that such non-compliance shall be a default of this Lease.

28.4. Local Business Enterprises. The Port Commission encourages the participation of local business enterprises ("LBEs") in Tenant's operations. Tenant agrees to consult with CMD to determine appropriate methods for promoting participation by LBEs. Architecture, Engineering, Laboratory Services (Materials Testing), Trucking and Hauling, and Security Guard Services are categories of services that may provide opportunities for certified LBE participation. City maintains a list of certified LBEs at: <https://sfgov.org/cmd/LBE-certification-0>.

28.5. Indoor Air Quality. Tenant agrees to comply with Section 711(g) of the Environment Code and any additional regulations adopted by the Director of the Department of the Environment pursuant to Environment Code Section 703(b) relating to construction and maintenance protocols to address indoor air quality.

28.6. Prohibition Against Tobacco Advertising; Prohibition Against Tobacco Product Sales, Manufacture, and Distribution. Tenant acknowledges and agrees that no advertising of cigarettes or tobacco products is allowed on the Premises. This advertising prohibition includes

the placement of the name of a company producing cigarettes or tobacco products or the name of any cigarette or tobacco product in any promotion of any event or product. In addition, Tenant acknowledges and agrees that no Sales, Manufacture, or Distribution of Tobacco Products (as such capitalized terms are defined in Health Code Section 19K.1) is allowed on the Premises and such prohibition must be included in all subleases or other agreements allowing use of the Premises. The prohibition against Sales, Manufacture, or Distribution of Tobacco Products does not apply to persons who are affiliated with an accredited academic institution where the Sale, Manufacture, and/or Distribution of Tobacco Products is conducted as part of academic research.

28.7. Prohibition of Alcoholic Beverages Advertising. Tenant acknowledges and agrees that no advertising of alcoholic beverages is allowed on the Premises. For purposes of this section, "alcoholic beverage" shall be defined as set forth in California Business and Professions Code Section 23004, and shall not include cleaning solutions, medical supplies and other products and substances not intended for drinking. This advertising prohibition includes the placement of the name of a company producing, selling or distributing alcoholic beverages or the name of any alcoholic beverage in any promotion of any event or product. This advertising prohibition does not apply to any advertisement sponsored by a state, local, nonprofit or other entity designed to (i) communicate the health hazards of alcoholic beverages, (ii) encourage people not to drink alcohol or to stop drinking alcohol, or (iii) provide or publicize drug or alcohol treatment or rehabilitation services.

28.8. Graffiti Removal. Tenant agrees to remove all graffiti from the Premises, including from the exterior of the Facility if included within the Premises, within forty-eight (48) hours of the earlier of Tenant's: (a) discovery or notification of the graffiti or (b) receipt of notification of the graffiti from the Department of Public Works. This section is not intended to require a tenant to breach any lease or other agreement that it may have concerning its use of the real property. "Graffiti" means any inscription, word, figure, marking or design that is affixed, marked, etched, scratched, drawn or painted on any building, structure, fixture or other improvement, whether permanent or temporary, including signs, banners, billboards and fencing surrounding construction sites, whether public or private, without the consent of the owner of the property or the owner's authorized agent, and that is visible from the public right-of-way, but does not include: (1) any sign or banner that is authorized by, and in compliance with, the applicable requirements of this Lease or the Port Building Code; or (2) any mural or other painting or marking on the property that is protected as a work of fine art under the California Art Preservation Act (Calif. Civil Code §§ 987 et seq.) or as a work of visual art under the Federal Visual Artists Rights Act of 1990 (17 U.S.C. §§ 101 et seq.).

28.9. Restrictions on the Use of Pesticides. Chapter 3 of the San Francisco Environment Code (the Integrated Pest Management Program Ordinance or "IPM Ordinance") describes an integrated pest management ("IPM") policy to be implemented by all City departments. Tenant shall not use or apply or allow the use or application of any pesticides on the Premises, and shall not contract with any party to provide pest abatement or control services to the Premises, without first receiving City's written approval of an integrated pest management plan that (i) lists, to the extent reasonably possible, the types and estimated quantities of pesticides that Tenant may need to apply to the Premises during the term of this Lease, (ii) describes the steps Tenant will take to meet the City's IPM Policy described in Section 300 of the IPM Ordinance and (iii) identifies, by name, title, address and telephone number, an individual to act as the Tenant's primary IPM contact person with the City. Tenant shall comply, and shall require all of Tenant's contractors to comply, with the IPM plan approved by the City and shall comply with the requirements of Sections 300(d), 302, 304, 305(f), 305(g), and 306 of the IPM Ordinance, as if Tenant were a City department. Among other matters, such provisions of the IPM Ordinance: (a) provide for the use of pesticides only as a last resort, (b) prohibit the use or application of pesticides on property owned by the City, except for pesticides granted an exemption under Section 303 of the IPM Ordinance (including pesticides included on the most current Reduced Risk Pesticide List compiled by City's Department of the Environment), (c)

impose certain notice requirements, and (d) require Tenant to keep certain records and to report to City all pesticide use by Tenant's staff or contractors. If Tenant or Tenant's contractor will apply pesticides to outdoor areas, Tenant must first obtain a written recommendation from a person holding a valid Agricultural Pest Control Advisor license issued by the California Department of Pesticide Regulation and any such pesticide application shall be made only by or under the supervision of a person holding a valid Qualified Applicator certificate or Qualified Applicator license under state law. City's current Reduced Risk Pesticide List and additional details about pest management on City property can be found at the San Francisco Department of the Environment website, <http://sfenvironment.org/ipm>.

28.10. *MacBride Principles Northern Ireland.* Port and the City urge companies doing business in Northern Ireland to move towards resolving employment inequities, and encourages such companies to abide by the MacBride Principles. Port and the City urge San Francisco companies to do business with corporations that abide by the MacBride Principles.

28.11. *Tropical Hardwood and Virgin Redwood Ban.* Port and the City urge Tenant not to import, purchase, obtain or use for any purpose, any tropical hardwood, tropical hardwood wood product, virgin redwood or virgin redwood product. Except as expressly permitted by the application of Sections 802(b) and 803(b) of the Environment Code, Tenant shall not provide any items to the construction of Alterations, or otherwise in the performance of this Lease which are tropical hardwoods, tropical hardwood wood products, virgin redwood, or virgin redwood wood products. In the event Tenant fails to comply in good faith with any of the provisions of Chapter 8 of the Environment Code, Tenant shall be liable for liquidated damages for each violation in any amount equal to the contractor's net profit on the contract, or five percent (5%) of the total amount of the contract dollars, whichever is greater.

28.12. *Preservative-Treated Wood Containing Arsenic.* Tenant may not purchase preservative-treated wood products containing arsenic in the performance of this Lease unless an exemption from the requirements of Environment Code Chapter 13 is obtained from the Department of Environment under Section 1304 of the Environment Code. The term "preservative-treated wood containing arsenic" shall mean wood treated with a preservative that contains arsenic, elemental arsenic, or an arsenic copper combination, including, but not limited to, chromated copper arsenate preservative, ammoniac copper zinc arsenate preservative, or ammoniacal copper arsenate preservative. Tenant may purchase preservative-treated wood products on the list of environmentally preferable alternatives prepared and adopted by the Department of Environment. This provision does not preclude Tenant from purchasing preservative-treated wood containing arsenic for saltwater immersion. The term "saltwater immersion" shall mean a pressure-treated wood that is used for construction purposes or facilities that are partially or totally immersed in saltwater.

28.13. *Notification of Limitations on Contributions.* If this Lease is subject to the approval by City's Board of Supervisors, Mayor, or other elected official, the provisions of this Section 28.13 shall apply. Through its execution of this Lease, Tenant acknowledges its obligations under Section 1.126 of the San Francisco Campaign and Governmental Conduct Code, which prohibits any person who contracts with the City for the selling or leasing of any land or building to or from the City whenever such transaction would require approval by a City elective officer or the board on which that City elective officer serves, from making any campaign contribution to (a) the City elective officer, (b) a candidate for the office held by such individual, or (c) a committee controlled by such individual or candidate, at any time from the submission of a proposal for the contract until the later of either the termination of negotiations for such contract or twelve (12) months after the date the contract is approved. Tenant acknowledges that the foregoing restriction applies only if the contract or a combination or series of contracts approved by the same individual or board in a fiscal year have a total anticipated or actual value of one hundred thousand dollars (\$100,000) or more. Tenant further acknowledges that, if applicable, (i) the prohibition on contributions applies to each Tenant; each member of Tenant's board of directors, and Tenant's principal officers, including its chairperson, chief

executive officer, chief financial officer and chief operating officer; any person with an ownership interest of more than ten (10%) percent in Tenant; and any subcontractor listed in the Tenant's bid or contract; and (ii) within thirty (30) days of the submission of a proposal for the contract, the Port is obligated to submit to the Ethics Commission the parties to the Lease and any subtenant(s). Additionally, Tenant certifies that if this Section 28.13 applies, Tenant has informed each of the persons described in the preceding sentence of the prohibitions contained in Section 1.126 by the time it submitted a proposal for the contract and has provided to City the names of the persons required to be informed.

28.14. *Sunshine Ordinance.* In accordance with Section 67.24(e) of the Administrative Code, contracts, contractors' bids, leases, agreements, responses to Requests for Proposals, and all other records of communications between Port and persons or firms seeking contracts will be open to inspection immediately after a contract has been awarded. Nothing in this provision requires the disclosure of a private person's or organization's net worth or other proprietary financial data submitted for qualification for a contract, lease, agreement or other benefit until and unless that person or organization is awarded the contract, lease, agreement or benefit. Information provided which is covered by this Section will be made available to the public upon request.

28.15. *Conflicts of Interest.* Through its execution of this Lease, Tenant acknowledges that it is familiar with the provisions of Article III, Chapter 2 of Campaign and Governmental Conduct Code, and Sections 87100 et seq. and Sections 1090 et seq. of the California Government Code, and certifies that it does not know of any facts which would constitute a violation of these provisions, and agrees that if Tenant becomes aware of any such fact during the Term, Tenant shall immediately notify the Port.

28.16. *Drug-Free Workplace.* Tenant acknowledges that pursuant to the Federal Drug-Free Workplace Act of 1988 (41 U.S.C. §§ 8101 et seq.), the unlawful manufacture, distribution, possession or use of a controlled substance is prohibited on City or Port premises.

28.17. *Prevailing Wages and Working Conditions.* Tenant shall comply with all applicable prevailing wage requirements, including but not limited to any such requirements in the California Labor Code, the City and County of San Francisco Charter or the City and County of San Francisco Municipal Code. Any undefined, initially-capitalized term used in this Section shall have the meaning given to such term in San Francisco Administrative Code Section 23.61. Tenant shall require its contractors and subcontractors performing (i) labor in connection with a "public work" as defined under California Labor Code Section 1720 et seq. (which includes certain construction, alteration, maintenance, demolition, installation, repair, carpet laying, or refuse hauling work if paid for in whole or part out of public funds) or (ii) Covered Construction to: (A) pay workers performing such work not less than the highest prevailing rate of wages, (B) provide the same hours, working conditions and benefits as in each case are provided for similar work performed in San Francisco County, and (C) employ apprentices in accordance with San Francisco Administrative Code Section 23.61 (collectively, "**Prevailing Wage Requirements**"). Tenant agrees to cooperate with the City in any action or proceeding against a contractor or subcontractor that fails to comply with the Prevailing Wage Requirements.

Tenant shall include and shall require its subtenants, and contractors and subcontractors (regardless of tier), to include the Prevailing Wage Requirements and the agreement to cooperate in City enforcement actions in any Construction Contract with specific reference to San Francisco Administrative Code Section 23.61. Each such Construction Contract shall name the City and County of San Francisco, affected workers, and employee organizations formally representing affected workers as third party beneficiaries for the limited purpose of enforcing the Prevailing Wage Requirements, including the right to file charges and seek penalties against any contractor or subcontractor in accordance with San Francisco Administrative Code Section 23.61. Tenant's failure to comply with its obligations under this Section shall constitute a material breach of this Lease. A contractor's or subcontractor's failure to comply with this

Section will enable the City to seek any remedy provided by Law, including those specified in San Francisco Administrative Code Section 23.61 against the breaching party.

Tenant shall also pay, and shall require its subtenants, and contractors and subcontractors (regardless of tier) to pay, the Prevailing Rate of Wage for the following activities on the Premises as set forth in and to the extent required by San Francisco Administrative Code Chapter 21C: a Public Off-Street Parking Lot, Garage or Automobile Storage Facility (as defined in Section 21C.3), a Show (as defined in Section 21C.4), a Special Event (as defined in Section 21C.8), Broadcast Services (as defined in Section 21C.9), Commercial Vehicles, Loading and Unloading for Shows and Special Events (as defined in Section 21C.10), and Security Guard Services for Events (as defined in Section 21C.11).

28.18. Local Hire. Any undefined, initially-capitalized term used in this Section shall have the meaning given to such term in San Francisco Administrative Code Section 23.62 (the "**Local Hiring Requirements**"). Tenant Improvements and Alterations under this Lease are subject to the Local Hiring Requirements unless the cost for such work is (i) estimated to be less than \$750,000 per building permit; (ii) is in connection with the set-up, execution and strike of special events of three (3) or fewer days costing in excess of the Threshold Amount; or (iii) meets any of the other exemptions in the Local Hiring Requirements. Tenant agrees that it will comply with the Local Hiring Requirements to the extent applicable. Before starting any Tenant Improvements or Alterations, Tenant shall contact City's Office of Economic Workforce and Development ("**OEWD**") to determine whether the work is a Covered Project subject to the Local Hiring Requirements.

Tenant shall include, and shall require its subtenants to include, a requirement to comply with the Local Hiring Requirements in any contract for a Covered Project with specific reference to San Francisco Administrative Code Section 23.62. Each such contract shall name the City and County of San Francisco as a third party beneficiary for the limited purpose of enforcing the Local Hiring Requirements, including the right to file charges and seek penalties. Tenant shall cooperate, and require its subtenants to cooperate, with the City in any action or proceeding against a contractor or subcontractor that fails to comply with the Local Hiring Requirements when required. Tenant's failure to comply with its obligations under this Section shall constitute a material breach of this Lease. A contractor's or subcontractor's failure to comply with this Section will enable the City to seek the remedies specified in San Francisco Administrative Code Section 23.62 against the breaching party.

28.19. Public Transit Information. Tenant shall establish and carry on during the Term a program to encourage maximum use of public transportation by personnel of Tenant employed on the Premises, including, without limitation, the distribution to such employees of written materials explaining the convenience and availability of public transportation facilities adjacent or proximate to the Facility and encouraging use of such facilities, all at Tenant's sole expense.

28.20. Food Service and Packaging Waste Reduction Ordinance. Tenant agrees to comply fully with and be bound by all of the provisions of the Food Service and Packaging Waste Reduction Ordinance, as set forth in Environment Code Chapter 16, including the remedies provided, and implementing guidelines and rules. By entering into this Lease, Tenant agrees that if it breaches this provision, City will suffer actual damages that will be impractical or extremely difficult to determine; further, Tenant agrees that the sum of one hundred dollars (\$100.00) liquidated damages for the first breach, two hundred dollars (\$200.00) liquidated damages for the second breach in the same year, and five hundred dollars (\$500.00) liquidated damages for-subsequent breaches in the same year is a reasonable estimate of the damage that City will incur based on the violation, established in light of the circumstances existing at the time this Lease was made. Such amounts shall not be considered a penalty, but rather agreed monetary damages sustained by City because of Tenant's failure to comply with this provision.

28.21. San Francisco Bottled Water Ordinance. Tenant is subject to all applicable provisions of Environment Code Chapter 24 (which are hereby incorporated) prohibiting the sale

or distribution of drinking water specified containers at City-permitted events held on the Premises with attendance of more than 100 people, except as otherwise set forth in Environmental Code Chapter 24.

28.22. Consideration Of Criminal History In Hiring And Employment Decisions.

(a) Tenant agrees to comply with and be bound by all of the provisions of San Francisco Administrative Code Chapter 12T (Criminal History in Hiring and Employment Decisions; “**Chapter 12T**”), which are hereby incorporated, including the remedies and implementing regulations as may be amended from time to time, with respect to applicants and employees of Tenant who would be or are performing work at the Premises.

(b) Tenant shall incorporate by reference the provisions of Chapter 12T in all subleases of some or all of the Premises, and shall require all subtenants to comply with such provisions. Tenant’s failure to comply with the obligations in this subsection shall constitute a material breach of this Lease.

(c) Tenant and subtenants shall not inquire about, require disclosure of, or if such information is received base an Adverse Action on an applicant’s or potential applicant for employment, or employee’s: (1) Arrest not leading to a Conviction, unless the Arrest is undergoing an active pending criminal investigation or trial that has not yet been resolved; (2) participation in or completion of a diversion or a deferral of judgment program; (3) a Conviction that has been judicially dismissed, expunged, voided, invalidated, or otherwise rendered inoperative; (4) a Conviction or any other adjudication in the juvenile justice system; (5) a Conviction that is more than seven years old, from the date of sentencing; or (6) information pertaining to an offense other than a felony or misdemeanor, such as an infraction.

(d) Tenant and subtenants shall not inquire about or require applicants, potential applicants for employment, or employees to disclose on any employment application the facts or details of any conviction history, unresolved arrest, or any matter identified in subsection (c) above. Tenant and subtenants shall not require such disclosure or make such inquiry until either after the first live interview with the person, or after a conditional offer of employment.

(e) Tenant and subtenants shall state in all solicitations or advertisements for employees that are reasonably likely to reach persons who are reasonably likely to seek employment with Tenant or subtenant at the Premises, that the Tenant or subtenant will consider for employment qualified applicants with criminal histories in a manner consistent with the requirements of Chapter 12T.

(f) Tenant and subtenants shall post the notice prepared by OLSE, available on OLSE’s website, in a conspicuous place at the Premises and at other workplaces within San Francisco where interviews for job opportunities at the Premises occur. The notice shall be posted in English, Spanish, Chinese, and any language spoken by at least 5% of the employees at the Premises or other workplace at which it is posted.

(g) Tenant and subtenants understand and agree that upon any failure to comply with the requirements of Chapter 12T, the City shall have the right to pursue any rights or remedies available under Chapter 12T or this Lease, including but not limited to a penalty of \$50 for a second violation and \$100 for a subsequent violation for each employee, applicant or other person as to whom a violation occurred or continued, termination or suspension in whole or in part of this Lease.

(h) If Tenant has any questions about the applicability of Chapter 12T, it may contact Port for additional information. Port may consult with the Director of the City’s Office of Contract Administration who may also grant a waiver, as set forth in Section 12T.8.

28.23. Vending Machines; Nutritional Standards and Calorie Labeling Requirements; Offerings. Tenant shall not install or permit any vending machine on the Premises without the prior written consent of Port. Any permitted vending machine must comply with the food and

beverage nutritional standards and calorie labeling requirements set forth in San Francisco Administrative Code section 4.9- 1(c), as may be amended from time to time (the “**Nutritional Standards Requirements**”). Tenant agrees to incorporate the Nutritional Standards Requirements into any contract for the installation of a vending machine on the Premises or for the supply of food and beverages to that vending machine. Failure to comply with the Nutritional Standards Requirements or to otherwise comply with this Section shall be deemed a material breach of this Lease. Without limiting Port’s other rights and remedies under this Lease, Port shall have the right to require the immediate removal of any vending machine on the Premises that is not permitted or that violates the Nutritional Standards Requirements. In addition, any Restaurant including any employee eating establishment located on the Premises is encouraged to ensure that at least twenty-five percent (25%) of Meals (as capitalized terms are defined in San Francisco Administrative Code section 4.9-1) offered on the menu meet the nutritional standards set forth in San Francisco Administrative Code section 4.9-1(e), as may be amended.

28.24. Tenant’s Compliance with City Business and Tax Regulations Code.

Tenant acknowledges that under Section 6.10-2 of the San Francisco Business and Tax Regulations Code, the City Treasurer and Tax Collector may require the withholding of payments to any vendor that is delinquent in the payment of any amounts that the vendor is required to pay the City under the San Francisco Business and Tax Regulations Code. If, under that authority, any payment Port is required to make to Tenant under this Lease is withheld, then Port will not be in breach or default under this Lease, and the Treasurer and Tax Collector will authorize release of any payments withheld under this Section 28.27 to Tenant, without interest, late fees, penalties, or other charges, upon Tenant coming back into compliance with its San Francisco Business and Tax Regulations Code obligations.

28.25. Consideration of Salary History. Tenant shall comply with San Francisco Administrative Code Chapter 12K, the Consideration of Salary History Ordinance or "Pay Parity Act." For each employment application to Tenant for work that relates to this Lease or for work to be performed in the City or on City property, Tenant is prohibited from considering current or past salary of an applicant in determining whether to hire the applicant or what salary to offer the applicant. Tenant shall not (1) ask such applicants about their current or past salary or (2) disclose a current or former employee's salary history without that employee's authorization unless the salary history is publicly available. Tenant is subject to the enforcement and penalty provisions in Chapter 12K. Information about Chapter 12K is available on the web at <https://sfgov.org/olse/consideration-salary-history>.

29. NOTICES.

Except as otherwise expressly provided in this Lease or by Law, all notices (including notice of consent or non-consent) required or permitted by this Lease or by Law must be in writing and be delivered by: (a) hand delivery; (b) first class United States mail, postage prepaid; or (c) overnight delivery by a nationally recognized courier or the United State Postal Service, delivery charges prepaid. Notices to a party must be delivered to that party's mailing address in the Basic Lease Information, unless superseded by a notice of a change in that party's mailing address for notices, given to the other party in the manner provided above, or by information provided by Tenant in Tenant's written response to Port's written request for such information.

All notices under this Lease shall be deemed to be duly delivered: (a) on the date personal delivery actually occurs; (b) if mailed, on the business day following the business day deposited in the United States mail or, if mailed return receipt requested, on the date of delivery or on which delivery is refused as shown on the return receipt; or (c) the business day after the business day deposited for overnight delivery.

Notices may not be given by facsimile or electronic mail, but either party may deliver a courtesy copy of a notice by facsimile or electronic mail.

30. MISCELLANEOUS PROVISIONS.

30.1. *California Law; Venue.* This Lease is governed by, and shall be construed and interpreted in accordance with, the Laws of the State of California and City's Charter. Any legal suit, action, or proceeding arising out of or relating to this Lease shall be instituted in the Superior Court for the City and County of San Francisco, and each party agrees to the exclusive jurisdiction of such court in any such suit, action, or proceeding (excluding bankruptcy matters). The parties irrevocably and unconditionally waive any objection to the laying of venue of any suit, action, or proceeding in such court and irrevocably waive and agree not to plead or claim that any suit, action, or proceeding brought in San Francisco Superior Court relating to this Lease has been brought in an inconvenient forum. The parties also unconditionally and irrevocably waive any right to remove any such suit, action, or proceeding to Federal Court.

30.2. *Entire Agreement.* This Lease contains all of the representations and the entire agreement between the parties with respect to the subject matter of this Lease. Any prior correspondence, memoranda, agreements, warranties, or representations, whether written or oral, relating to such subject matter are superseded in total by this Lease. No prior drafts of this Lease or changes from those drafts to the executed version of this Lease shall be introduced as evidence in any litigation or other dispute resolution proceeding by any party or other person, and no court or other body should consider those drafts in interpreting this Lease.

30.3. *Amendments.* No amendment of this Lease or any part thereof shall be valid unless it is in writing and signed by all of the parties hereto.

30.4. *Severability.* If any provision of this Lease or the application thereof to any person, entity or circumstance shall, to any extent, be invalid or unenforceable, the remainder of this Lease, or the application of such provision to persons, entities or circumstances other than those as to which is invalid or unenforceable, shall not be affected thereby, and each other provision of this Lease shall be valid and be enforceable to the fullest extent permitted by law.

30.5. *Interpretation of Lease.*

(a) References in this Lease to Tenant's acts or omissions will mean acts or omissions by Tenant and its Agents and Invitees unless the context requires or specifically stated otherwise.

(b) Whenever an exhibit or schedule is referenced, it means an attachment to this Lease unless otherwise specifically identified. All exhibits and schedules are incorporated in this Lease by reference.

(c) Whenever a section, article or paragraph is referenced, it refers to this Lease unless otherwise specifically provided. The captions preceding the articles and sections of this Lease and in the table of contents have been inserted for convenience of reference only and must be disregarded in the construction and interpretation of this Lease. Wherever reference is made to any provision, term, or matter "in this Lease," "herein" or "hereof" or words of similar import, the reference will be deemed to refer to any reasonably related provisions of this Lease in the context of the reference, unless the reference refers solely to a specific numbered or lettered article, section, subdivision, or paragraph of this Lease.

(d) References to all Laws, including specific statutes, relating to the rights and obligations of either party mean the Laws in effect on the effective date of this Lease and as they are amended, replaced, supplemented, clarified, corrected, or superseded at any time during the Term or while any obligations under this Lease are outstanding, whether or not foreseen or contemplated by the parties. References to specific code sections mean San Francisco ordinances unless otherwise specified.

(e) The terms "include," "included," "including" and "such as" or words of similar import when following any general term, statement, or matter may not be construed to limit the term, statement, or matter to the specific items or matters, whether or not language of non-

limitation is used, but will be deemed to refer to all other items or matters that could reasonably fall within the broadest possible scope of the term, statement, or matter, and will be deemed to be followed by the phrase "without limitation" or "but not limited to."

(f) This Lease has been negotiated at arm's length between persons sophisticated and knowledgeable in the matters addressed. In addition, each party has been represented by experienced and knowledgeable legal counsel, or has had the opportunity to consult with counsel. Accordingly, the provisions of this Lease must be construed as a whole according to their common meaning in order to achieve the intents and purposes of the parties, without any presumption (including a presumption under California Civil Code § 1654) against the party responsible for drafting any part of this Lease.

(g) The party on which any obligation is imposed in this Lease will be solely responsible for paying all costs and expenses incurred in performing the obligation, unless the provision imposing the obligation specifically provides otherwise.

(h) Whenever required by the context, the singular includes the plural and vice versa, the masculine gender includes the feminine or neuter genders and vice versa, and defined terms encompass all correlating forms of the terms (e.g., the definition of "waive" applies to "waiver," "waivers," "waived," "waiving," etc.).

(i) References to days mean calendar days unless otherwise specified, provided that if the last day on which a party must give notice, respond to a notice, or take any other action under this Lease occurs on a day that is not a business day, the date by which the act must be performed will be extended to the next business day.

30.6. Successors. The terms, covenants, agreements and conditions set forth in this Lease shall bind and inure to the benefit of Port and Tenant and, except as otherwise provided herein, their personal representatives and successors and assigns.

30.7. Real Estate Broker's Fees. Port will not pay, nor will Port be liable or responsible for, any finder's or broker's fee in connection with this Lease. Tenant agrees to Indemnify Port from any Claims, including attorneys' fees, incurred by Port in connection with any such Claim or Claims of any person(s), finder(s), or broker(s) to a commission in connection with this Lease.

30.8. Counterparts. For convenience, the signatures of the parties to this Lease may be executed and acknowledged on separate pages which, when attached to this Lease, shall constitute one complete Lease. This Lease may be executed in any number of counterparts each of which shall be deemed to be an original and all of which shall constitute one and the same Lease.

30.9. Authority. If Tenant signs as a corporation or a partnership, each of the persons executing this Lease on behalf of Tenant does hereby covenant and warrant that Tenant is at the time of execution and at all times while this Lease is in effect will continue to be: (1) a duly authorized and existing entity, and (2) qualified to do business in California; and that Tenant has full right and authority to enter into this Lease, and that each and all of the persons signing on behalf of Tenant are authorized to do so. Upon Port's request, Tenant shall provide Port with evidence reasonably satisfactory to Port confirming the foregoing representations, warranties and covenants.

30.10. No Implied Waiver. No failure by Port to insist upon the strict performance of any obligation of Tenant under this Lease or to exercise any right, power or remedy arising out of a breach thereof, irrespective of the length of time for which such failure continues, and no acceptance of full or partial Rent during the continuance of any such breach shall constitute a waiver of such breach or of Port's rights to demand strict compliance with such term, covenant or condition. Port's consent to or approval of any act by Tenant requiring Port's consent or approval shall not be deemed to waive or render unnecessary Port's consent to or approval of any

subsequent act by Tenant. Any waiver by Port of any default must be in writing and shall not be a waiver of any other default (including any future default) concerning the same or any other provision of this Lease.

30.11. *Time is of Essence.* Time is of the essence with respect to all provisions of this Lease in which a definite time for performance is specified.

30.12. *Cumulative Remedies.* All rights and remedies of either party hereto set forth in this Lease shall be cumulative, except as may otherwise be provided herein.

30.13. *Survival of Indemnities.* Termination or expiration of this Lease shall not affect the right of either party to enforce any and all indemnities and representations and warranties given or made to the other party under this Lease, the ability to collect any sums due, nor shall it affect any provision of this Lease that expressly states it shall survive termination or expiration hereof.

30.14. *Relationship of the Parties.* Port is not, and none of the provisions in this Lease shall be deemed to render Port, a partner in Tenant's business, or joint venturer or member in any joint enterprise with Tenant. Neither party shall act as the agent of the other party in any respect hereunder. This Lease is not intended nor shall it be construed to create any third party beneficiary rights in any third party, unless otherwise expressly provided.

30.15. *No Recording.* Tenant shall not record this Lease or any memorandum hereof in the Official Records.

30.16. *Additional Written Agreement Required.* Tenant expressly agrees and acknowledges that no officer, director, or employee of Port or City is authorized to offer or promise, nor is Port or the City required to honor, any offered or promised rent credit, concession, abatement, or any other form of monetary consideration (individually and collectively, "**Concession**") without a written agreement executed by the Executive Director of Port or his or her designee authorizing such Concession and, if applicable, certification of the Concession from the City's Controller.

31. LIMITATION ON DAMAGES.

31.1. *No Recourse Beyond Value of Premises.* Notwithstanding anything to the contrary contained in this Lease, Tenant agrees that Tenant will have no recourse with respect to, and Port shall not be liable for, any obligation of Port under this Lease, or for any claim based upon this Lease, except to the extent of the fair market value of Port's fee interest in the Premises (as encumbered by this Lease). Tenant shall look solely to the fair market value of Port's fee interest in the Premises for the recovery of any judgment or award. By Tenant's execution and delivery hereof and as part of the consideration for Port's obligations hereunder, Tenant expressly waives all other liability. Before filing suit for an alleged default by Port, Tenant shall give Port notice and reasonable time to cure the alleged default.

31.2. *Non-Liability of City Officials, Employees and Agents.* No elective or appointive board, commission, member, officer, employee or other Agent of City and/or Port shall be personally liable to Tenant, its successors and assigns, in the event of any default or breach by City and/or Port or for any amount which may become due to Tenant, its successors and assigns, or for any obligation of City and/or Port under this Lease. Under no circumstances shall Port, City, or their respective Agents be liable under any circumstances for any consequential, incidental or punitive damages.

31.3. *Limitation on Port's Liability Upon Transfer.* In the event of any transfer of Port's interest in and to the Facility, Port (and in case of any subsequent transfers, the then transferor), subject to the provisions hereof, will be automatically relieved from and after the date of such transfer of all liability with regard to the performance of any covenants or obligations contained in this Lease thereafter to be performed on the part of Port, but not from liability incurred by Port (or such transferor, as the case may be) on account of covenants or

obligations to be performed by Port (or such transferor, as the case may be) hereunder before the date of such transfer.

32. TENANT ESTOPPEL CERTIFICATES.

Tenant, at any time and from time to time upon not less than ten (10) days' prior notice from Port, shall execute and deliver to Port or to any party designated by Port a certificate in substantially the same form as that attached to this Lease as *Exhibit C*. If Tenant shall fail to provide such certificate within ten (10) days of receipt by Tenant of a written request by Port as herein provided, such failure shall, at Port's election, constitute a default under this Lease, and Tenant shall be deemed to have admitted the accuracy of any information supplied by Port to a prospective purchaser or mortgagee.

33. EXTENSION OPTION.

33.1. *Option to Extend Term.* Tenant may exercise its Extension Option by giving Port no less than sixty (60) days' prior written notice prior to the expiration date of its intent to exercise the Extension Option for the Premises. Any such notice by Tenant shall be irrevocable by Tenant. If any Event of Default by Tenant has occurred or is outstanding hereunder either at the time of Tenant's exercise of the Extension Option or at any time prior to the first day of the Extension Term (or if any event shall have occurred which with the giving of notice or the passage of time or both would constitute such a default), then Port may elect by written notice to Tenant to reject Tenant's exercise of the Extension Option, whereupon the Extension Option shall be null and void and the Term shall expire on the day the Term would have expired had Tenant never exercised the Extension Option.

33.2. *Base Rent and Other Terms.* If Tenant elects to exercise the Extension Option, then the lease for the Extension Term shall cover the Premises and shall be upon all of the terms, covenants and conditions of this Lease, except that the Expiration Date shall mean the last day of the Extension Term and the Base Rent hereunder shall be determined as set forth in the Basic Lease Information.

34. APPROVAL OF BOARD OF SUPERVISORS.

NOTWITHSTANDING ANYTHING TO THE CONTRARY CONTAINED IN THIS LEASE, TENANT ACKNOWLEDGES AND AGREES THAT NO OFFICER OR EMPLOYEE OF CITY HAS AUTHORITY TO COMMIT CITY TO THIS LEASE UNLESS AND UNTIL CITY'S BOARD OF SUPERVISORS SHALL HAVE DULY ADOPTED A RESOLUTION APPROVING THIS LEASE AND AUTHORIZING THE TRANSACTIONS CONTEMPLATED HEREBY. THEREFORE, ANY OBLIGATIONS OR LIABILITIES OF CITY HEREUNDER ARE CONTINGENT UPON ADOPTION OF SUCH A RESOLUTION AND THIS LEASE SHALL BE NULL AND VOID IF CITY'S MAYOR AND THE BOARD OF SUPERVISORS DO NOT APPROVE THIS LEASE, IN THEIR RESPECTIVE SOLE DISCRETION. APPROVAL OF THIS LEASE BY ANY DEPARTMENT, COMMISSION OR AGENCY OF CITY SHALL NOT BE DEEMED TO IMPLY THAT SUCH RESOLUTION WILL BE ENACTED, NOR WILL ANY SUCH APPROVAL CREATE ANY BINDING OBLIGATIONS ON CITY.

[REMAINDER OF PAGE INTENTIONALLY LEFT BLANK]

IN WITNESS WHEREOF, PORT and TENANT execute this Lease as of the last date set forth below.

PORT: **CITY AND COUNTY OF SAN FRANCISCO,**
a municipal corporation, operating by and through the
SAN FRANCISCO PORT COMMISSION

By: _____
Rebecca Benassini
Deputy Director, Real Estate and Development

Date Signed: _____

TENANT: **AUTODESK, INC. A DELAWARE CORPORATION**

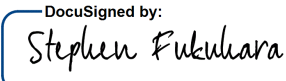
DocuSigned by:

By: _____
Name: ~~STEPHEN FUKUHARA~~ Stephen Fukuhara
Title: VP, workplace & Travel

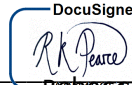
Date Signed: 11/4/2022

DocuSigned by:

By: _____
Name: ~~REBECCA PEARCE~~ Rebecca Pearce
Title: Executive Vice President, Chief People Officer

Date Signed: 11/7/2022

APPROVED AS TO FORM:
DAVID CHIU, City Attorney

By: _____
Name: A. Mathai-Jackson
Deputy City Attorney

Lease Prepared By: Vicky Lee, Commercial Property Manager _____
(initial)

[PAGE INTENTIONALLY LEFT BLANK]

EXHIBIT A-1

DESCRIPTION OF PREMISES

[Attachment on following page]

[PAGE INTENTIONALLY LEFT BLANK]

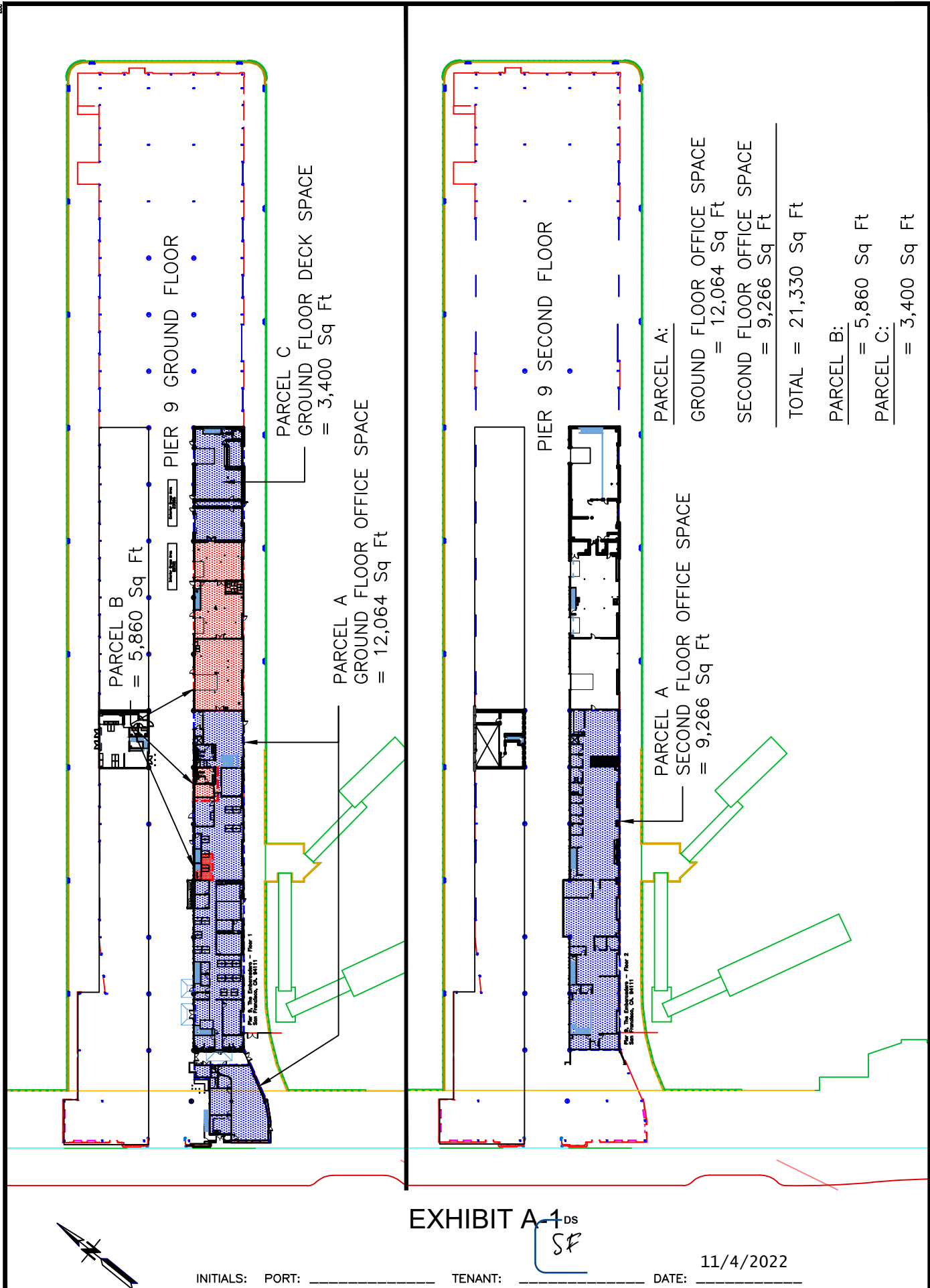

LEASE NO. L-16848	 SAN FRANCISCO PORT COMMISSION PORT OF SAN FRANCISCO DEPARTMENT OF ENGINEERING	TENANT AUTODESK, INC.	DRAWN BY: E.D. CHECKED BY: V. LEE PLACE CODE NO. 1090-00	DATE: DEC 9, 2021 SCALE: 1" = 100' SHEET NO. 1090-00 OF SHEETS
			6:\06 PROPERTY FILES\LEASE MAPS\EXHIBITS-PIERS\PIER09\PA-AUTODESK_20211217	

EXHIBIT A-2

DESCRIPTION OF SOLAR LICENSE AREA

[Attachment on following page]

[PAGE INTENTIONALLY LEFT BLANK]

Exhibit A-2

Autodesk Solar Panels License 8/29/13

Exh A-2

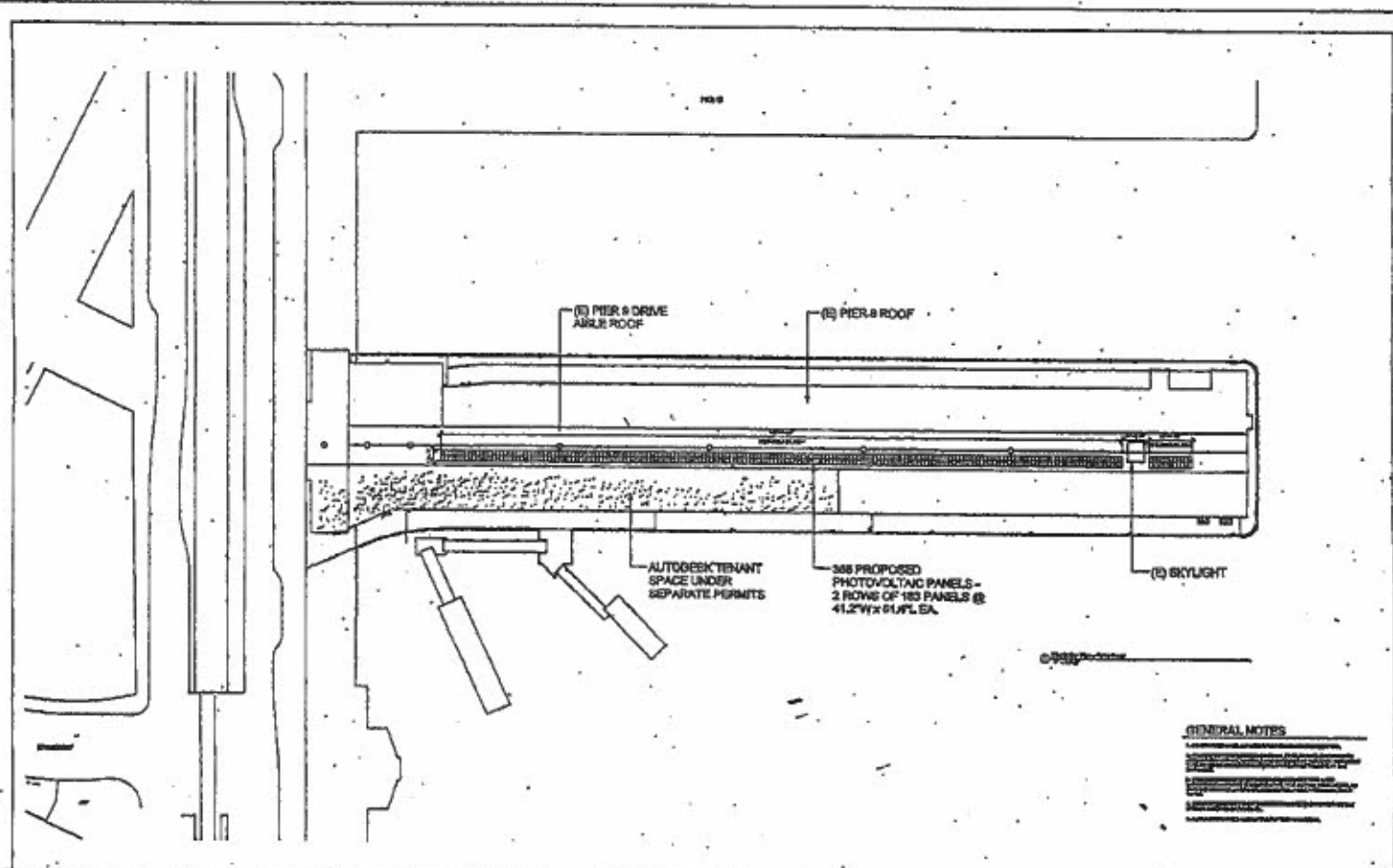

<p>PROGRESS PRINT - NOT FOR CONSTRUCTION</p>		<p>Autodesk - Pier 9</p> <p>1000 MARKET STREET, SUITE 1000, SAN FRANCISCO, CA 94102</p>		<p>Proposed Site Plan</p>	<p>A2.0d</p>
--	--	---	--	---------------------------	--------------

Initial :
Port:

Tenant: DS SF

EXHIBIT A-3

DESCRIPTION OF PUBLIC ACCESS PARCEL

[Attachment on following page]

[PAGE INTENTIONALLY LEFT BLANK]

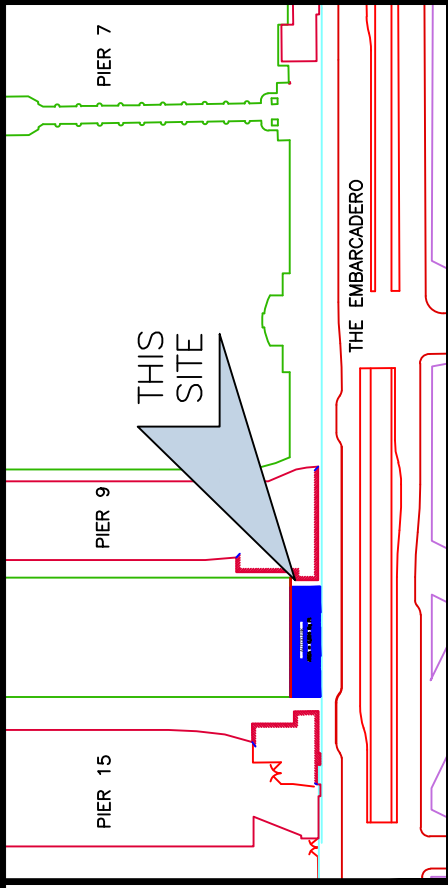

LOCATION PLAN
NO SCALE

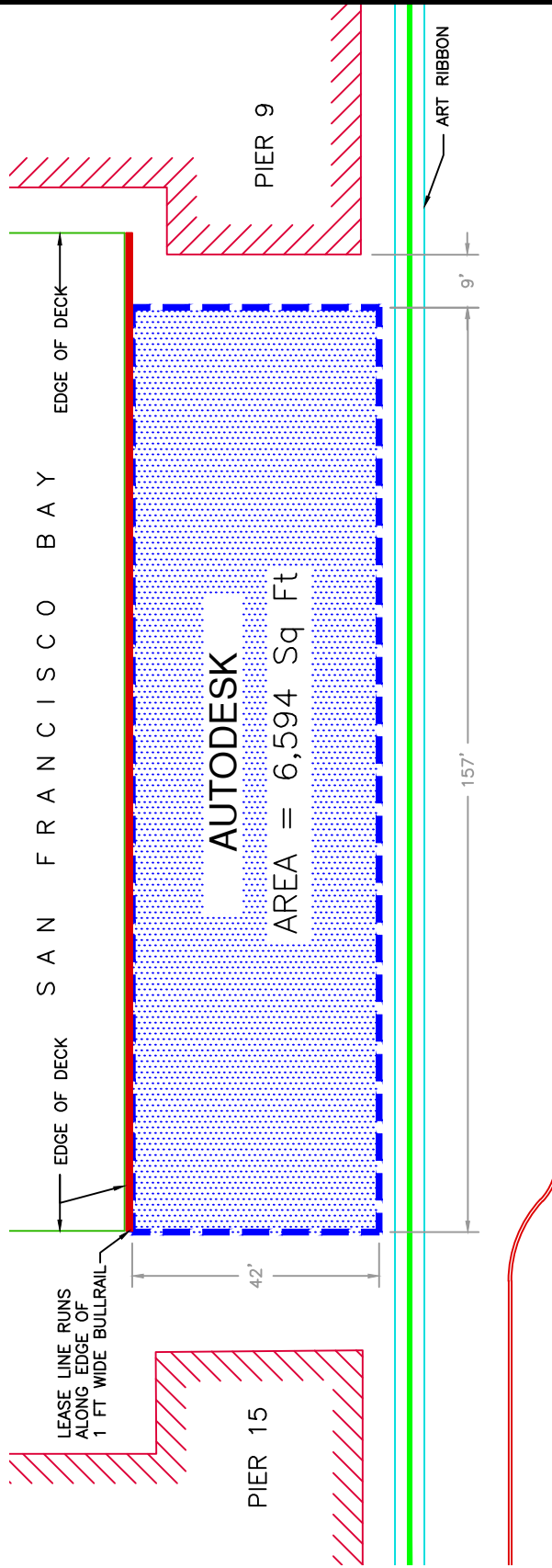

THE EMBARCADERO

SCALE: 1" = 30'



EXHIBIT A-3^{DS}
SF

INITIALS: PORT: _____ TENANT: _____ DATE: 11/4/2022

LEASE NO. L-16848	 SAN FRANCISCO PORT COMMISSION PORT OF SAN FRANCISCO DEPARTMENT OF ENGINEERING	TENANT AUTODESK	DRAWN BY: ECC EDITED BY: E.D. DATE: SEPT. 6, 2022 CHECKED BY: V. LEE SCALE: AS SHOWN PLACE CODE NO. 1095-01 SHEET NO. OF SHEETS

EXHIBIT A-4

PLAN AND DESCRIPTION OF PUBLIC IMPROVEMENTS

[Attachment on following page]

[PAGE INTENTIONALLY LEFT BLANK]

Exhibit A-4

PROJECT AREA

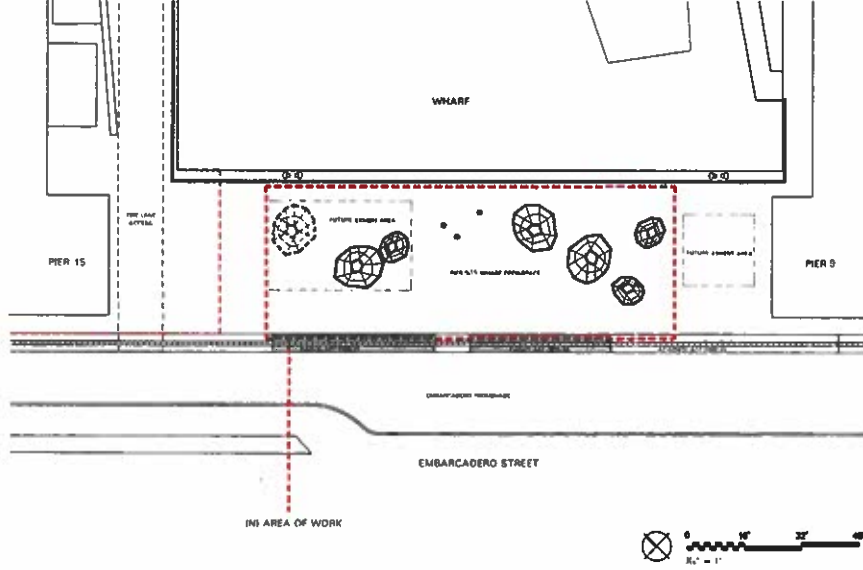

LOCATION MAP



Pier 9-15 Wharf Open Space, SAN FRANCISCO
MTS

INDEX OF DRAWINGS

- LANDSCAPE**
- L0.0 INDEX
 - L1.0 LAYOUT PLAN
 - L2.0 MATERIALS PLAN
 - L3.0 CONCEPTUAL LIGHTING PLAN
 - L4.0 ADA ACCESS PLAN
 - L5.0 DETAILS
 - L5.1 DETAILS
 - LS.4 SEATING LAYOUT PLAN
 - SK-1 PORT RAILING DETAILS

PROJECT DIRECTORY

PROJECT MANAGER
 Jeffrey Loehmann
 Construction Project Manager
 Corporate Real Estate and Facilities
 Autodesk, Inc.
 111 McInnis Parkway
 San Rafael, California 94903

LANDSCAPE ARCHITECT
 SURFACE DESIGN INC.
 12 DECATUR STREET
 SAN FRANCISCO, CA 94103
 415.621.5522

GENERAL CONTRACTOR
 QUERON PLAZA
 DPR Construction
 945 FRONT STREET
 SAN FRANCISCO, CA 94111
 LIC. NO. 953749 exp 10/14

PROJECT DATA

SITE LOCATION
 Pier 9-15 Wharf Open Space
 San Francisco, CA
 APN9900-0038

Initial:

Port:

Tenant:

DS
SF

NOTES:
 ▲ REFER TO SHEET 1 FOR THE DEVELOPER'S SITE PLAN (MOUNTAIN VIEW).
 THE DEVELOPER HAS PROVIDED THE NEAREST PUBLIC TRANSPORTATION STATION.
 THE DEVELOPER HAS PROVIDED THE NEAREST PUBLIC TRANSPORTATION STATION.
 THE DEVELOPER HAS PROVIDED THE NEAREST PUBLIC TRANSPORTATION STATION.

REV	DATE	DESCRIPTION	BY
1.0	10/11/11	PROVISIONAL PERMIT SET	MTS
2.0	10/11/11	PERMIT SET	MTS
3.0	10/11/11	PERMIT SET	MTS
4.0	10/11/11	PERMIT SET	MTS
5.0	10/11/11	PERMIT SET	MTS
6.0	10/11/11	PERMIT SET	MTS
7.0	10/11/11	PERMIT SET	MTS
8.0	10/11/11	PERMIT SET	MTS
9.0	10/11/11	PERMIT SET	MTS
10.0	10/11/11	PERMIT SET	MTS
11.0	10/11/11	PERMIT SET	MTS
12.0	10/11/11	PERMIT SET	MTS
13.0	10/11/11	PERMIT SET	MTS
14.0	10/11/11	PERMIT SET	MTS
15.0	10/11/11	PERMIT SET	MTS
16.0	10/11/11	PERMIT SET	MTS
17.0	10/11/11	PERMIT SET	MTS
18.0	10/11/11	PERMIT SET	MTS
19.0	10/11/11	PERMIT SET	MTS
20.0	10/11/11	PERMIT SET	MTS

DESIGNER:
 SURFACE DESIGN INC.
 12 DECATUR STREET
 SAN FRANCISCO, CA 94103
 415.621.5522 P
 415.621.5513 F

PROJECT: Pier 9-15 WHARF OPEN SPACE

SHEET TITLE: INDEX

PHASE: PERMIT SET

SCALE: 1" = 1' L 0.00

1 LAYOUT PLAN
SCALE: 1/8" = 1'

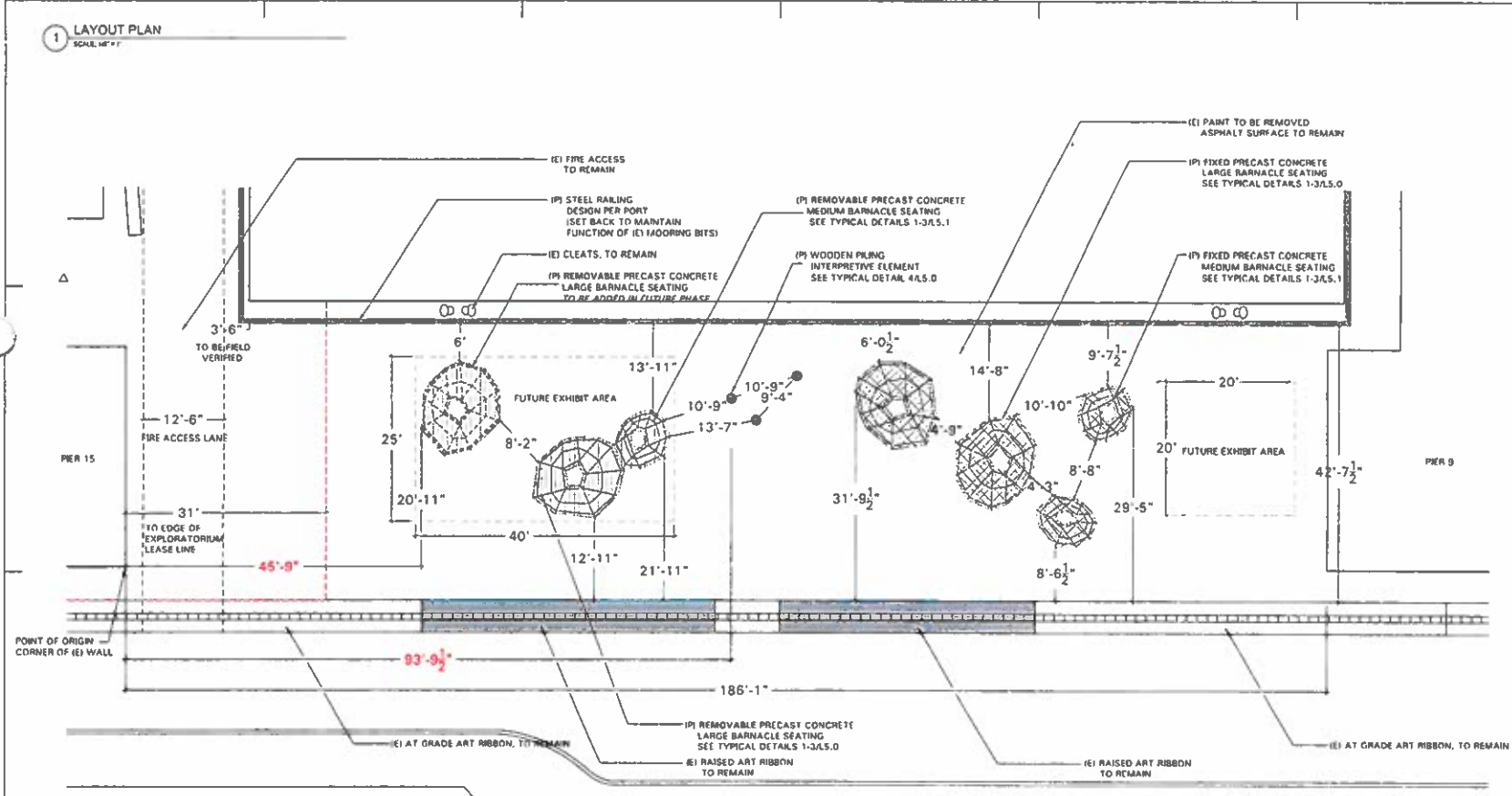

2 LEGEND

SYMBOL	DESCRIPTION
[Hatched Box]	FIXED BARNACLE SEATING ELEMENTS
[Dotted Box]	REMOVABLE BARNACLE SEATING ELEMENTS



NOTES:

- (E) TEMPORARY AMERICA'S CUP INSTALLATION, INCLUDING PAINT, TO BE REMOVED PRIOR TO CONSTRUCTION
- (I) RAILING TO BE SET BACK FROM (E) MOORING BITS TO MAINTAIN MARITIME ACCESS AND FUNCTION.
- (I) EVENT CAPACITY OF FUTURE SITE (ASSUMING 15 SQ FT/PERSON) = 420 PPL

NOTES

△ REMOVE PRIOR TO SETTING OF NEW PERMITS.

○ TO BE FIELD VERIFIED AND VERIFY DIMENSIONS TO BE ADDED TO THE LAYOUT PLAN.

○ DIMENSIONS SHOWN IN RED LINE ARE FIELD VERIFIED DIMENSIONS OR SURVEY

REV	DATE	DESCRIPTION	BY
1.0	11/17/11	PRELIMINARY DESIGN SUBMITTAL	MM
1.1	12/14/11	30% PERMIT SUBMITTAL	MM
1.2	01/10/12	PERMIT SET	MM
1.3	01/10/12	PERMIT SET	MM
1.4	01/10/12	PERMIT SET	MM
1.5	01/10/12	PERMIT SET	MM
1.6	01/10/12	PERMIT SET	MM
1.7	01/10/12	PERMIT SET	MM
1.8	01/10/12	PERMIT SET	MM
1.9	01/10/12	PERMIT SET	MM
1.10	01/10/12	PERMIT SET	MM
1.11	01/10/12	PERMIT SET	MM
1.12	01/10/12	PERMIT SET	MM
1.13	01/10/12	PERMIT SET	MM
1.14	01/10/12	PERMIT SET	MM
1.15	01/10/12	PERMIT SET	MM
1.16	01/10/12	PERMIT SET	MM
1.17	01/10/12	PERMIT SET	MM
1.18	01/10/12	PERMIT SET	MM
1.19	01/10/12	PERMIT SET	MM
1.20	01/10/12	PERMIT SET	MM

DESIGNER	SURFACED DESIGN INC. 2 Director Street San Francisco, CA 94103 415.871.3532 P 415.871.5515 F
PROJECT:	PIER 9-15 WHARF OPEN SPACE
SHEET TITLE:	LAYOUT PLAN
PROJECT:	PERMIT SET
SCALE:	1" = 1' L 1.00

1 MATERIALS PLAN

SCALE: 1/4" = 1'

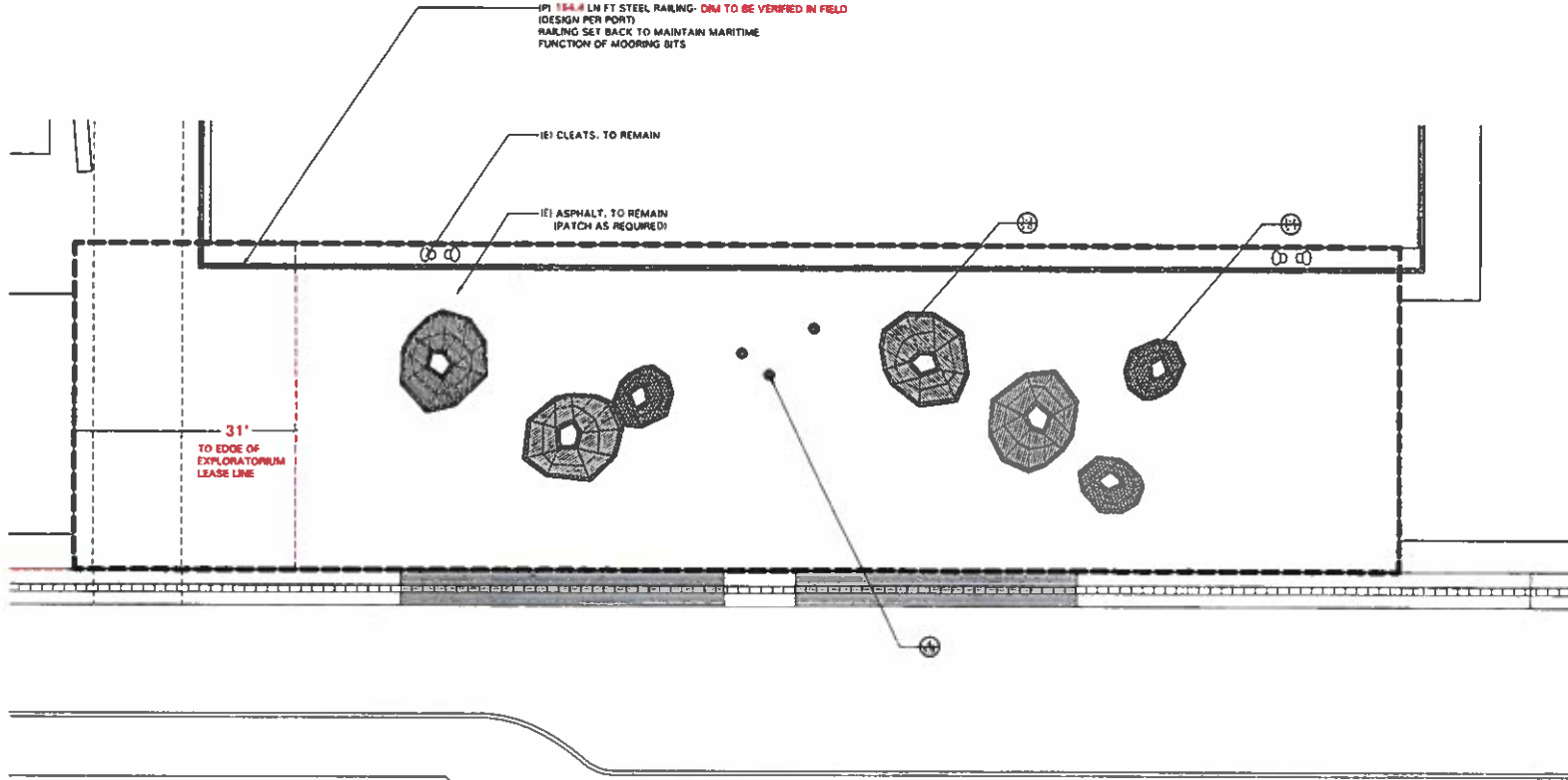

2 MATERIALS SCHEDULE

SYMBOL	DESCRIPTION	MATERIAL	FINISH	DIM.	QTY.	NOTES
	LARGE BARNACLE SEATING MODULE	PRECAST CONCRETE COLOR: ASH	POLISHED AND SEALED	PER PLAN	4	SEE TYPICAL DETAILS 1-3A 5.00
	MEDIUM BARNACLE SEATING MODULE	PRECAST CONCRETE COLOR: ASH	POLISHED AND SEALED	PER PLAN	3	SEE TYPICAL DETAILS 1-3A 6.10
	WOODEN PLANK INTERPRETIVE ELEMENT	RECLAIMED WOOD	SEALED	PER PLAN	3	SEE TYPICAL DETAIL 4A 5.00
	GROUND SURFACE	EXISTING ASPHALT TO BE CLEANED OF ALL PAINT	-	PER PLAN	-	

CUSTOM CONCRETE COLOR: CONCRETEWORKS
<http://www.concreteworks.com/masoncolor>

NOTES:
 1E) TEMPORARY AMERICA'S CUP INSTALLATION, INCLUDING PAINT, TO BE REMOVED PRIOR TO CONSTRUCTION
 1) RAILING TO BE SET BACK FROM 1E) MOORING BITS TO MAINTAIN MARITIME ACCESS AND FUNCTION.
 1) SEATING AND INTERPRETIVE ELEMENTS TO COMPLY TO ADA STANDARDS

NOTES:
 1) NUMBER OF STAKES TO BE VERIFIED PER OWNER REPRESENTATIVE.
 2) SEE TYPICAL DETAILS AND TYPICAL DETAILS FOR THE EXPLORATORIUM LEASE LINE.
 3) EXISTING ASPHALT TO BE CLEANED OF ALL PAINT.
 4) NUMBER OF STAKES TO BE VERIFIED PER OWNER REPRESENTATIVE.

REV.	DATE	BY	DESCRIPTION
01	01/15/2023	JL	ISSUED FOR PERMIT SET
02	01/15/2023	JL	ISSUED FOR PERMIT SET
03	01/15/2023	JL	ISSUED FOR PERMIT SET
04	01/15/2023	JL	ISSUED FOR PERMIT SET
05	01/15/2023	JL	ISSUED FOR PERMIT SET
06	01/15/2023	JL	ISSUED FOR PERMIT SET
07	01/15/2023	JL	ISSUED FOR PERMIT SET
08	01/15/2023	JL	ISSUED FOR PERMIT SET
09	01/15/2023	JL	ISSUED FOR PERMIT SET
10	01/15/2023	JL	ISSUED FOR PERMIT SET
11	01/15/2023	JL	ISSUED FOR PERMIT SET
12	01/15/2023	JL	ISSUED FOR PERMIT SET
13	01/15/2023	JL	ISSUED FOR PERMIT SET
14	01/15/2023	JL	ISSUED FOR PERMIT SET
15	01/15/2023	JL	ISSUED FOR PERMIT SET
16	01/15/2023	JL	ISSUED FOR PERMIT SET
17	01/15/2023	JL	ISSUED FOR PERMIT SET
18	01/15/2023	JL	ISSUED FOR PERMIT SET
19	01/15/2023	JL	ISSUED FOR PERMIT SET
20	01/15/2023	JL	ISSUED FOR PERMIT SET

DESIGNER:
 3200 WILSON BLVD
 1200 WILSON BLVD
 SAN FRANCISCO, CA 94103
 415.774.2020
 415.774.2020

PROJECT: PIER B-15 WHARF OPEN SPACE

SHEET TITLE: MATERIALS PLAN

PROJECT: PERMIT SET

SCALE: 1/4" = 1'

DATE: L 2.00

1 CONCEPTUAL LIGHTING PLAN
SCALE: 1/4" = 1'-0"

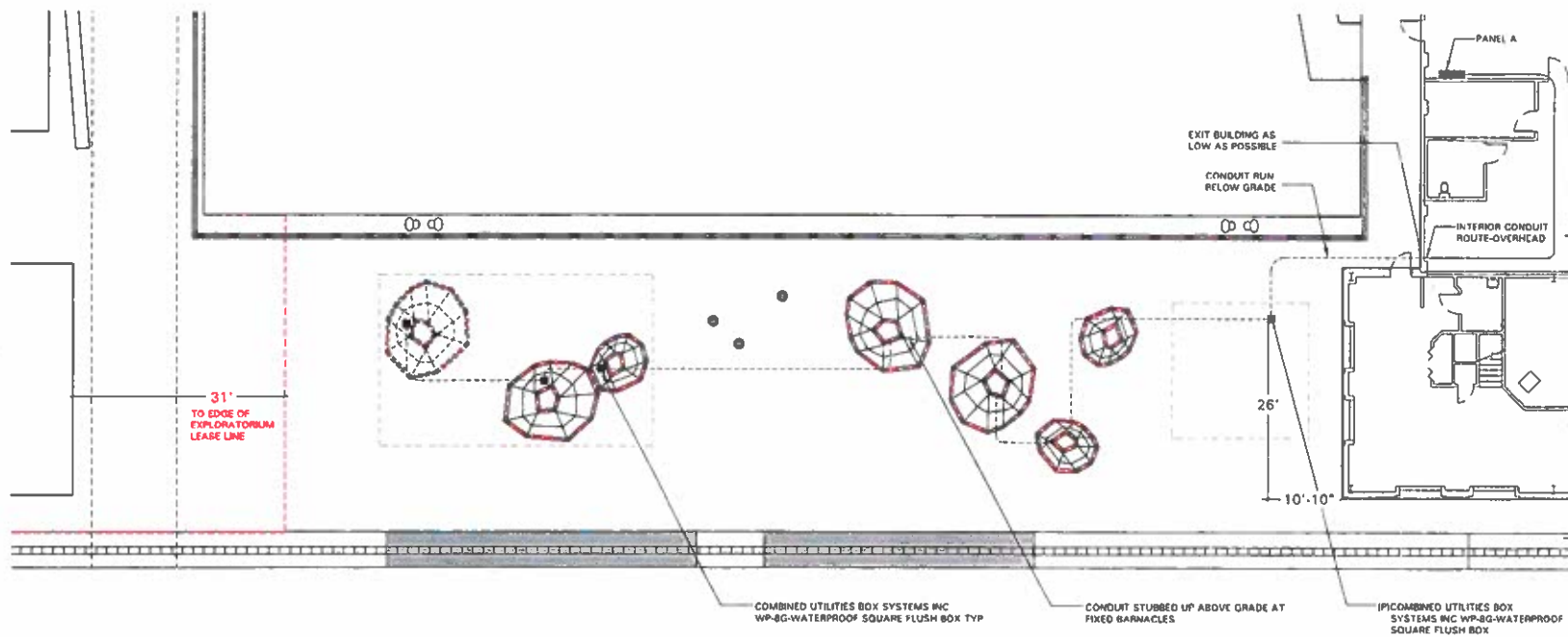

NOTES

1. ALL UTILITIES SHALL BE DEEPER THAN THE EXISTING UTILITIES.

2. ALL UTILITIES SHALL BE DEEPER THAN THE EXISTING UTILITIES.

3. ALL UTILITIES SHALL BE DEEPER THAN THE EXISTING UTILITIES.

4. ALL UTILITIES SHALL BE DEEPER THAN THE EXISTING UTILITIES.

5. ALL UTILITIES SHALL BE DEEPER THAN THE EXISTING UTILITIES.

6. ALL UTILITIES SHALL BE DEEPER THAN THE EXISTING UTILITIES.

7. ALL UTILITIES SHALL BE DEEPER THAN THE EXISTING UTILITIES.

8. ALL UTILITIES SHALL BE DEEPER THAN THE EXISTING UTILITIES.

9. ALL UTILITIES SHALL BE DEEPER THAN THE EXISTING UTILITIES.

10. ALL UTILITIES SHALL BE DEEPER THAN THE EXISTING UTILITIES.

REV	DATE	DESCRIPTION	BY
01		ISSUED FOR PERMIT	
02		REVISION	
03		REVISION	
04		REVISION	
05		REVISION	
06		REVISION	
07		REVISION	
08		REVISION	
09		REVISION	
10		REVISION	

2 LIGHTING LEGEND

SYMBOL	DESCRIPTION	MATERIAL	COLOR	QTY.	NOTES
---	NOVALEX 60 STANDARD OUTPUT STRIP LIGHTING	LED LIGHT STRIP	WARM WHITE	650 LM FT	NOVALEX-60, ST-1, RECESSED BY REVEAL AT BASE OF BARNACLES
■	COMBINED UTILITIES BOX SYSTEMS INC WP-BG-WATERPROOF SQUARE FLUSH BOX	STAINLESS STEEL	-	4	SEE ATTACHED CUT SHEET

3 EXTERIOR FLOOR BOX CUT SHEET

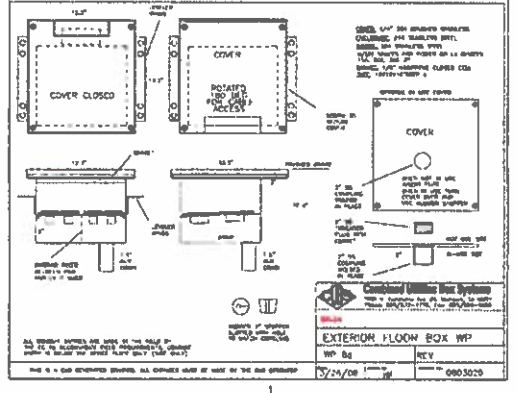

ON BOARD BY: **STURM-HACKENHAIN INC**
13 Devotion Street
San Francisco, CA 94103
415.637.5523 P
415.637.5415 F

PROJECT: PIER 9-15 WHARF OPEN SPACE

SHEET TITLE: CONCEPTUAL LIGHTING PLAN

PHASE: PERMIT SET

DATE: AUG 13/11

SCALE: 1/4" = 1'-0"

PROJECT NUMBER: L 3.00

1 ADA ACCESS PLAN
SCALE: 1/8" = 1'

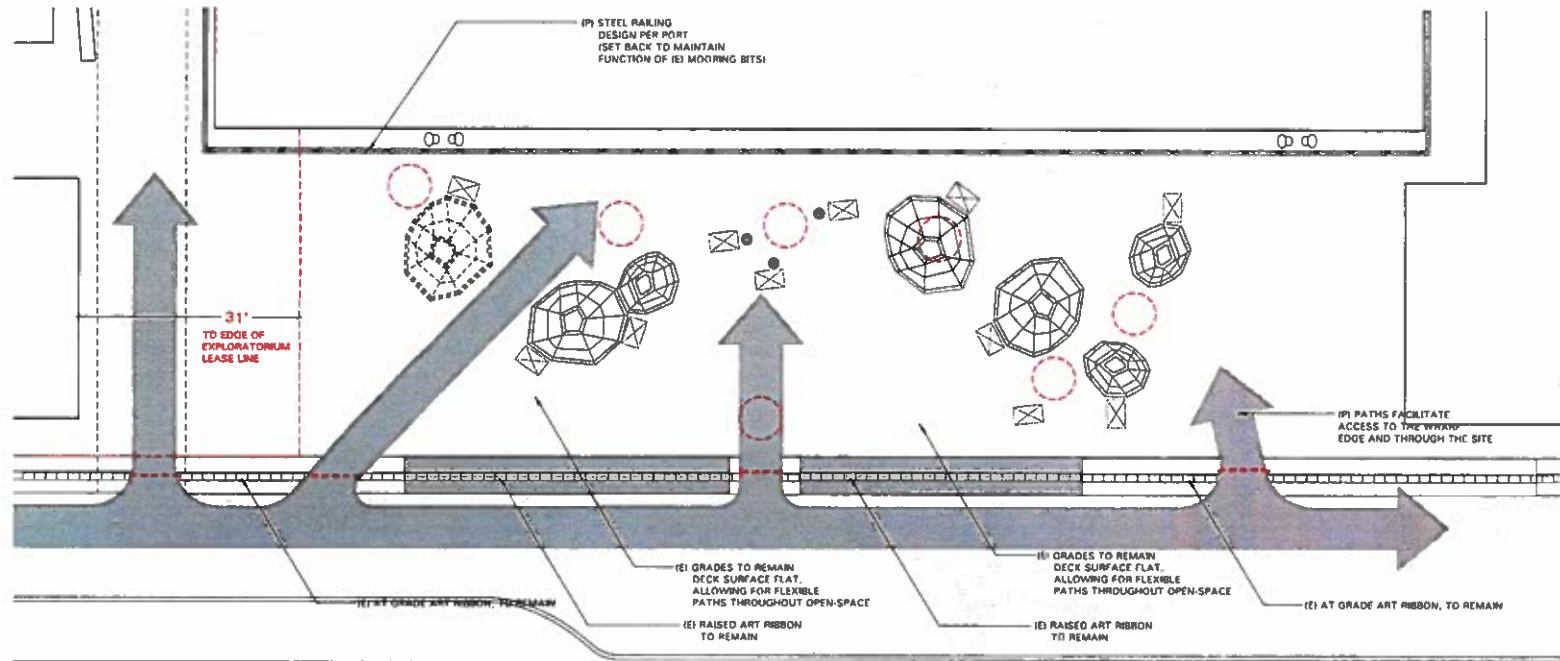

2 ADA LEGEND

SYMBOL	DESCRIPTION	INFORMATION	NOTES
	ADA ENTRANCE: 72" MINIMUM	UNOBSTRUCTED AREAS WHERE THERE IS THE LEAST AMOUNT OF RUNNING SLOPE	THE ENTIRE PER 9-15 WHARF OPEN SPACE SURFACE GRADES ARE TO REMAIN. ALL BARRICADES ARE SITUATED FOR MAXIMUM ADA CIRCULATION AND ACCESS TO THE WHARF RAILING EDGE AND THROUGH THE OPEN SPACE.
	WHEELCHAIR RESTING SPACE	30"x48" CLEAR FLOOR AREA WITH A CROSS SLOPE NO GREATER THAN 2%	WHERE RESTING SPACES ARE DELINEATED, THE ENTIRE PER 9-15 WHARF OPEN SPACE SURFACE GRADES ARE TO REMAIN AND THE FEATURES ARE SPACED TO MAXIMIZE OPPORTUNITIES TO CIRCULATE, REST AND TURNAROUND THROUGHOUT THE SPACE.
	WHEELCHAIR TURNING SPACE	60" RADII WHEELCHAIR TURNING SPACES ARE LOCATED NEAR BARRICADE SEATING AND SITE FEATURES IN ORDER TO MAXIMIZE CIRCULATION THROUGHOUT THE OPEN SPACE.	WHERE TURNING SPACES ARE DELINEATED, THE ENTIRE PER 9-15 WHARF OPEN SPACE SURFACE GRADES ARE TO REMAIN AND THE FEATURES ARE SPACED TO MAXIMIZE OPPORTUNITIES TO CIRCULATE, REST AND TURNAROUND THROUGHOUT THE SPACE.



NOTES:
 1. CONSULT THE ARCHITECT FOR THE EXISTING SITE INFORMATION.
 2. FOR KENNEDY SQUARE AND OTHER BARRICADES, REFER TO A PLAN DRAWING BEHIND THIS SHEET.
 3. EXISTING BARRICADES SHALL BE MAINTAINED AND THE RESPONSIBILITY FOR MAINTENANCE SHALL BE ASHES HOLDING.

REV	DATE	DESCRIPTION	BY
1.0	10/11/11	PRELIMINARY DESIGN DEVELOPMENT	MM
2.0	10/11/11	REVISIONS TO THE PRELIMINARY DESIGN	MM
3.0	10/11/11	REVISIONS TO THE PRELIMINARY DESIGN	MM
4.0	10/11/11	REVISIONS TO THE PRELIMINARY DESIGN	MM
5.0	10/11/11	REVISIONS TO THE PRELIMINARY DESIGN	MM
6.0	10/11/11	REVISIONS TO THE PRELIMINARY DESIGN	MM
7.0	10/11/11	REVISIONS TO THE PRELIMINARY DESIGN	MM
8.0	10/11/11	REVISIONS TO THE PRELIMINARY DESIGN	MM
9.0	10/11/11	REVISIONS TO THE PRELIMINARY DESIGN	MM
10.0	10/11/11	REVISIONS TO THE PRELIMINARY DESIGN	MM
11.0	10/11/11	REVISIONS TO THE PRELIMINARY DESIGN	MM
12.0	10/11/11	REVISIONS TO THE PRELIMINARY DESIGN	MM
13.0	10/11/11	REVISIONS TO THE PRELIMINARY DESIGN	MM
14.0	10/11/11	REVISIONS TO THE PRELIMINARY DESIGN	MM
15.0	10/11/11	REVISIONS TO THE PRELIMINARY DESIGN	MM
16.0	10/11/11	REVISIONS TO THE PRELIMINARY DESIGN	MM
17.0	10/11/11	REVISIONS TO THE PRELIMINARY DESIGN	MM
18.0	10/11/11	REVISIONS TO THE PRELIMINARY DESIGN	MM
19.0	10/11/11	REVISIONS TO THE PRELIMINARY DESIGN	MM
20.0	10/11/11	REVISIONS TO THE PRELIMINARY DESIGN	MM

DATE: 10/11/11
 PROJECT: PR R 9-15 WHARF OPEN SPACE
 SHEET TITLE: ADA ACCESS PLAN
 SCALE: 1/8" = 1'

PROJECT: PR R 9-15 WHARF OPEN SPACE
 SHEET TITLE: ADA ACCESS PLAN
 SCALE: 1/8" = 1'
 DATE: 10/11/11

1 TYPICAL LARGE PRECAST CONCRETE BARNACLE—PLAN VIEW
SCALE: 1/4" = 1'-0"

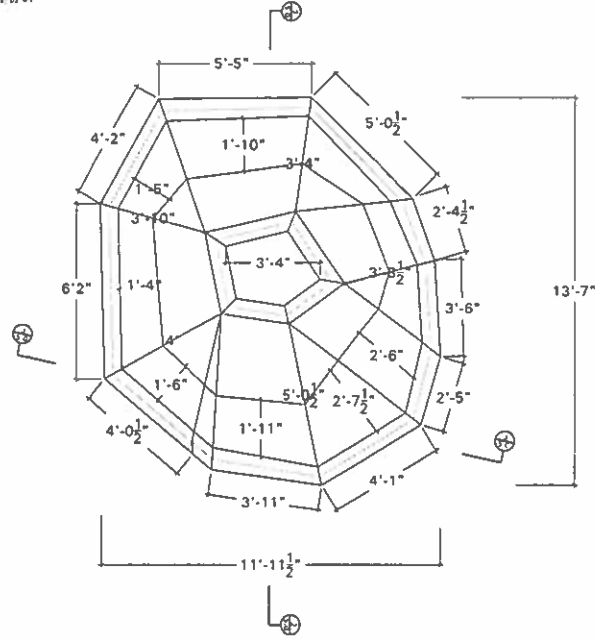

3 TYPICAL LARGE PRECAST CONCRETE BARNACLE—ELEVATION
SCALE: 1/4" = 1'-0"

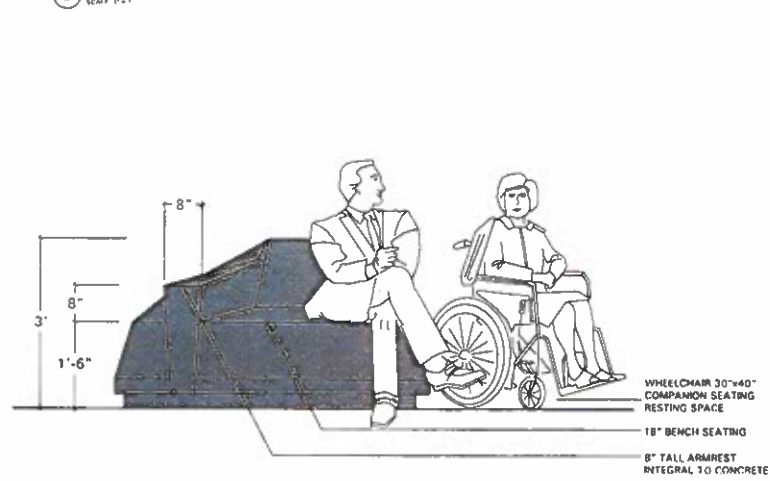

2 TYPICAL LARGE PRECAST CONCRETE BARNACLE—SECTION
SCALE: 1/4" = 1'-0"

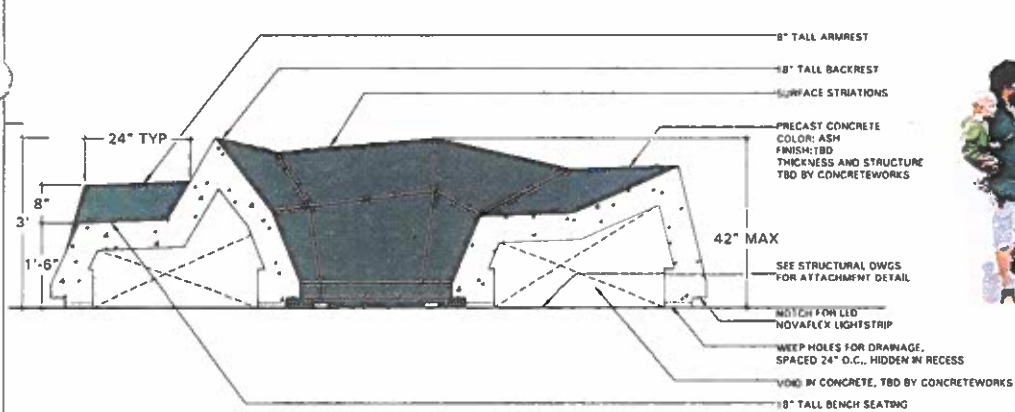

4 TYPICAL WOODEN PILING INTERPRETIVE ELEMENT—ELEVATION AND ILLUSTRATIVE
SCALE: 1/4" = 1'-0"

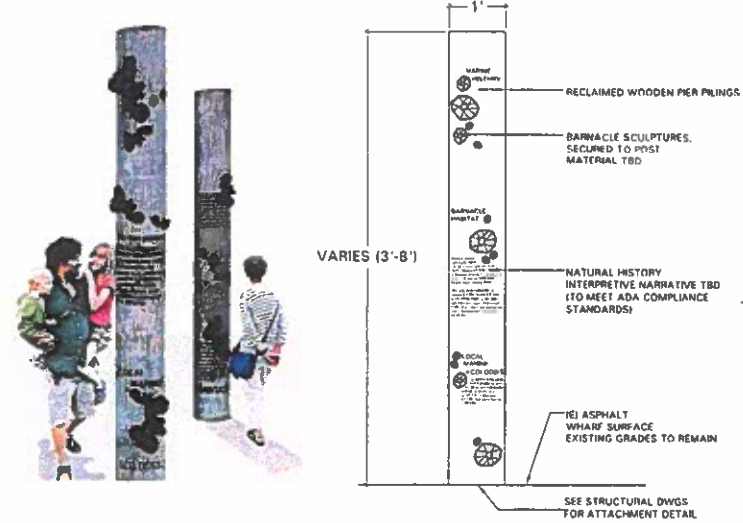

NOTES:

1. Material shall be per quantities per schedule.
2. All work shall be in accordance with the approved plans.
3. All work shall be in accordance with the approved plans.
4. All work shall be in accordance with the approved plans.

REV	DATE	BY	DESCRIPTION
01	07/12/17	JL	ISSUED FOR PERMIT SET
02	07/12/17	JL	ISSUED FOR PERMIT SET
03	07/12/17	JL	ISSUED FOR PERMIT SET
04	07/12/17	JL	ISSUED FOR PERMIT SET
05	07/12/17	JL	ISSUED FOR PERMIT SET
06	07/12/17	JL	ISSUED FOR PERMIT SET
07	07/12/17	JL	ISSUED FOR PERMIT SET
08	07/12/17	JL	ISSUED FOR PERMIT SET
09	07/12/17	JL	ISSUED FOR PERMIT SET
10	07/12/17	JL	ISSUED FOR PERMIT SET
11	07/12/17	JL	ISSUED FOR PERMIT SET
12	07/12/17	JL	ISSUED FOR PERMIT SET
13	07/12/17	JL	ISSUED FOR PERMIT SET
14	07/12/17	JL	ISSUED FOR PERMIT SET
15	07/12/17	JL	ISSUED FOR PERMIT SET
16	07/12/17	JL	ISSUED FOR PERMIT SET
17	07/12/17	JL	ISSUED FOR PERMIT SET
18	07/12/17	JL	ISSUED FOR PERMIT SET
19	07/12/17	JL	ISSUED FOR PERMIT SET
20	07/12/17	JL	ISSUED FOR PERMIT SET

DESIGNER: **SKIDMORE OWINGS & MERRILL**
300 Park Avenue
New York, NY 10022
Tel: (212) 512-2000
Fax: (212) 512-2100

PROJECT: PIER 9-15 WHARF OPEN SPACE

DATE: 07/12/17

SCALE: Varies L 5.00

DETAILS

1 TYPICAL MEDIUM PRECAST CONCRETE BARNACLE - PLAN VIEW
SCALE: 1" = 1'-0"

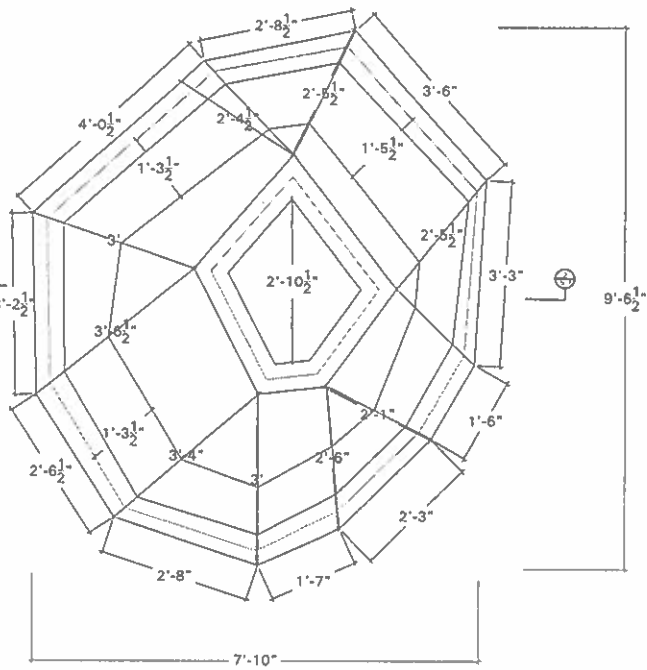

3 TYPICAL MEDIUM PRECAST CONCRETE BARNACLE - ELEVATION
SCALE: 1" = 1'-0"

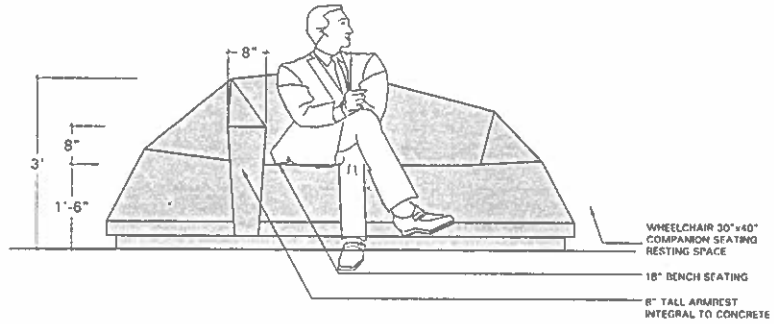

2 TYPICAL MEDIUM PRECAST CONCRETE BARNACLE - SECTION
SCALE: 1" = 1'-0"

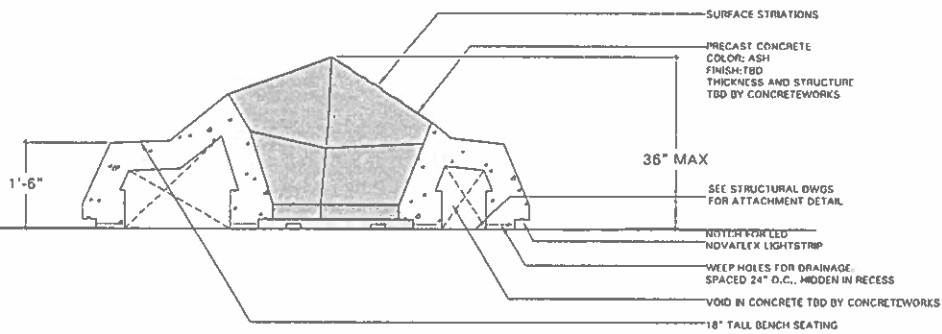

NOTES:
 1. ALL DIMENSIONS ARE TO FACE UNLESS OTHERWISE NOTED.
 2. ALL DIMENSIONS ARE TO FACE UNLESS OTHERWISE NOTED.
 3. ALL DIMENSIONS ARE TO FACE UNLESS OTHERWISE NOTED.
 4. ALL DIMENSIONS ARE TO FACE UNLESS OTHERWISE NOTED.

REV	DATE	BY	DESCRIPTION
1			
2			
3			
4			
5			
6			
7			
8			
9			
10			
11			
12			
13			
14			
15			
16			
17			
18			
19			
20			
21			
22			
23			
24			
25			
26			
27			
28			
29			
30			
31			
32			
33			
34			
35			
36			
37			
38			
39			
40			
41			
42			
43			
44			
45			
46			
47			
48			
49			
50			

DESIGNED BY: **SUPERIOR CONCRETE INC.**
 12000 S. 10th Street
 San Francisco, CA 94119
 415.621.8811 P
 415.621.8811 F

PROJECT: PIER 9-15 WHARF OPEN SPACE

SHEET TITLE: DETAILS

PERMIT: PERMIT SET

AUG 1980 VARIES L 5.10

1 SEATING LAYOUT PLAN
SCALE: 1/8" = 1'-0"

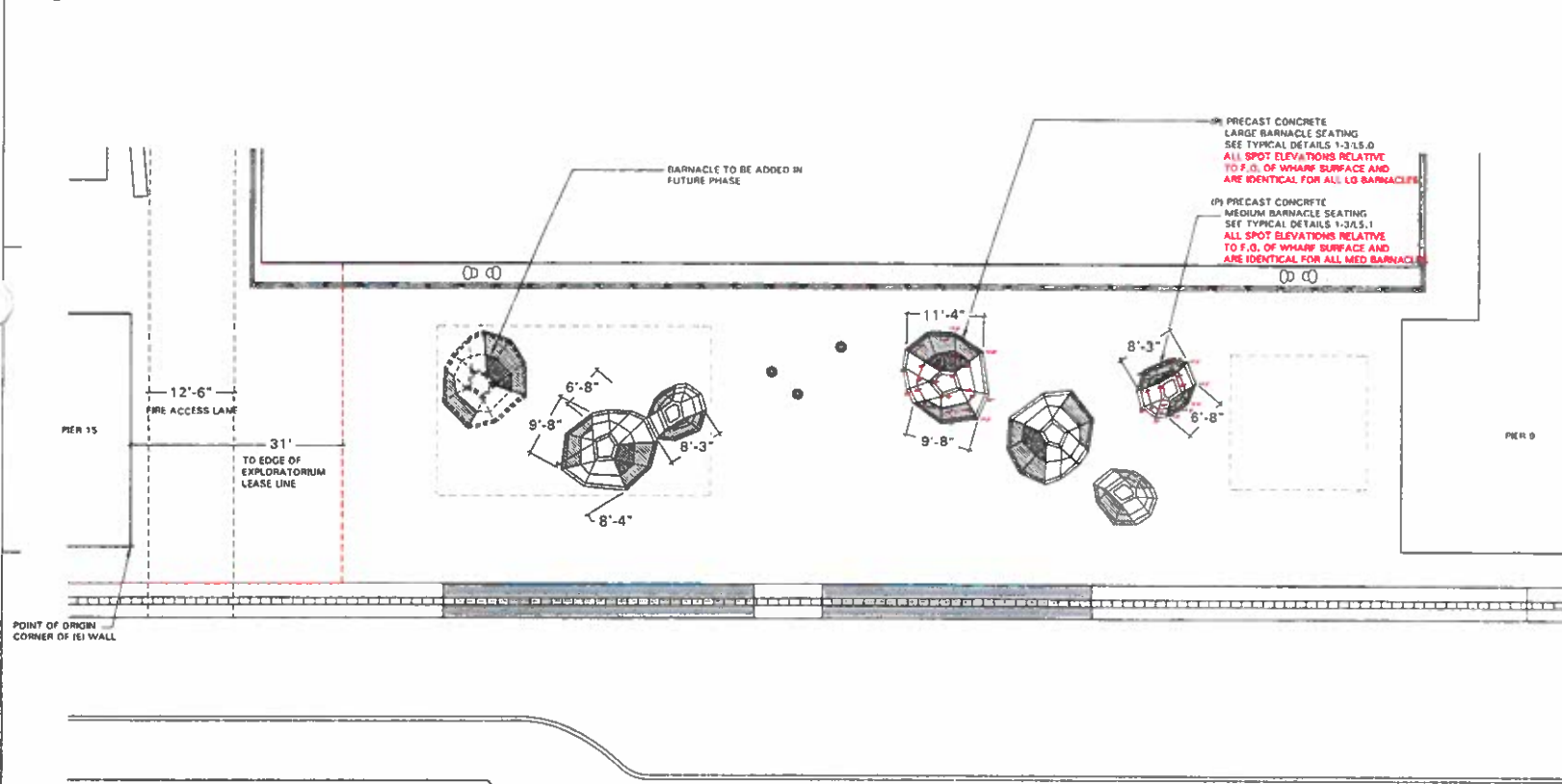

2 LEGEND

SYMBOL	DESCRIPTION	MATERIAL	FINISH	DIM.	NOTES
	FLAT SEATING AREAS, 18" ABOVE F.S.D.	PRECAST CONCRETE COLOR: ASH	POLISHED AND SEALED	PER PLAN	"SEAT" DEFINED AS: 18" x 18" FLAT SEATING SURFACE, 18" ABOVE F.S.D. 1/2" mesh across length to drain
	ADA COMPLIANT SEAT-BACKS.	PRECAST CONCRETE COLOR: ASH	POLISHED AND SEALED	PER PLAN	ADA COMPLIANT SEAT-BACKS, MAX HEIGHT 36", SEE 205.0.2(5.1)

3 SEATING SCHEDULE BY MODULE

SYMBOL	DESCRIPTION	MATERIAL	FINISH	QTY.	SEATING CAPACITY	TOTAL SEATS
	LARGE BARNACLE SEATING MODULE	PRECAST CONCRETE COLOR: ASH	POLISHED AND SEALED	4	12 SEATS (12 SEATS @ (1) BARNACLE ADDING MEDIUM BARNACLE)	48
	MEDIUM BARNACLE SEATING MODULE	PRECAST CONCRETE COLOR: ASH	POLISHED AND SEALED	3	7 SEATS	21
SITE TOTAL:						69

NOTES:

- See typical details for precast concrete seating.
- All spot elevations relative to F.S.D. of wharf surface and are identical for all LG barnacles.
- All spot elevations relative to F.S.D. of wharf surface and are identical for all MED barnacles.

REV	DATE	DESCRIPTION	BY
01	08/14/2018	ISSUED FOR PERMIT	MM
02	08/14/2018	REVISION: SEATING LAYOUT	MM
03	08/14/2018	REVISION: SEATING LAYOUT	MM
04	08/14/2018	REVISION: SEATING LAYOUT	MM
05	08/14/2018	REVISION: SEATING LAYOUT	MM
06	08/14/2018	REVISION: SEATING LAYOUT	MM
07	08/14/2018	REVISION: SEATING LAYOUT	MM
08	08/14/2018	REVISION: SEATING LAYOUT	MM
09	08/14/2018	REVISION: SEATING LAYOUT	MM
10	08/14/2018	REVISION: SEATING LAYOUT	MM
11	08/14/2018	REVISION: SEATING LAYOUT	MM
12	08/14/2018	REVISION: SEATING LAYOUT	MM
13	08/14/2018	REVISION: SEATING LAYOUT	MM
14	08/14/2018	REVISION: SEATING LAYOUT	MM
15	08/14/2018	REVISION: SEATING LAYOUT	MM
16	08/14/2018	REVISION: SEATING LAYOUT	MM
17	08/14/2018	REVISION: SEATING LAYOUT	MM
18	08/14/2018	REVISION: SEATING LAYOUT	MM
19	08/14/2018	REVISION: SEATING LAYOUT	MM
20	08/14/2018	REVISION: SEATING LAYOUT	MM

PROJECT: PIER 9-15 WHARF OPEN SPACE

SHEET TITLE: SEATING LAYOUT PLAN

PHASE: PERMIT SET

SCALE: 1/8" = 1'-0"

DATE: 08/14/2018

PROJECT NO: L 5.40

1 PORT RAILING DETAILS

MC&E-WTS

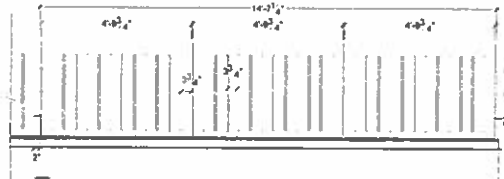

Plan Elevation
Scale: NTS

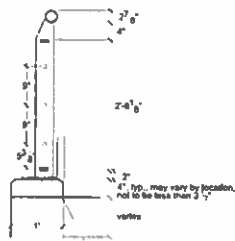

End Post
Scale: 1" = 1'

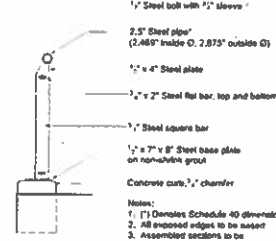

Intermediate Post
Scale: 1/2" = 1'



2 1/2" Steel pipe (schedule 40)
ease edges at ends
2.875" outside O
2.469" inside O

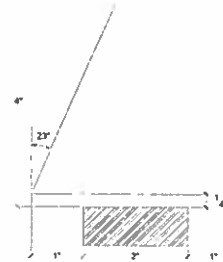

Top Rail Detail
Scale: 1:1

Port of San Francisco
G:\Railings\2012 Wharf Railings\2012 Wharf Railings - 2013-01-17.dwg

Wharf Railing
January 17, 2013



Perspective

- Railing Design:
- Total Length: approx. 15' per panel segment
 - Total Height: 42" min.
 - Top Rail: 2 1/2" steel pipe, ease ends 1" outside structure
 - Main Posts: 1/2" x 4" Steel Plate, approx. every 5'
 - Pickets: 3/4" square bars, Gaps: 3.54" max.
 - Concrete curb: 4" min. height from finished surface



Elevation



Main Posts Intermediate Posts End Posts

Wharf Railings
Port of San Francisco

Concept Design

BCDC Submittal Drawings 01/17/13

NOTES:
 1. All dimensions are in feet and inches unless otherwise noted.
 2. All dimensions are to be as shown unless otherwise noted.
 3. All dimensions are to be as shown unless otherwise noted.
 4. All dimensions are to be as shown unless otherwise noted.

REV	DATE	BY	CHKD	DESCRIPTION
1	01/17/13	MC&E-WTS	MC&E-WTS	Initial Design
2	01/17/13	MC&E-WTS	MC&E-WTS	Revised Design
3	01/17/13	MC&E-WTS	MC&E-WTS	Final Design

DESIGNER:
STANTEC CONSULTANTS INC.
 1200 California Street
 San Francisco, CA 94109
 415.774.2822
 415.774.2815

PROJECT: PIER 9-15 WHARF OPEN SPACE

SHEET TITLE: PORT RAILING DETAILS

PHASE: PERMIT SET

AUG 13 2013

SK-1

EXHIBIT B

COMMENCEMENT DATE AND EXPIRATION DATE MEMORANDUM

Landlord: **CITY AND COUNTY OF SAN FRANCISCO**, a municipal corporation,
operating by and through the **SAN FRANCISCO PORT
COMMISSION**

Tenant:

Lease Number:

Lease Date:

Premises: [_____, Suite ____]
San Francisco, California

The Commencement Date of the Lease is hereby established as _____, 20____, the
Rent Commencement Date of the Lease is hereby established as _____, 20____ the
Anniversary Date is hereby established as _____, 20____ and the Expiration Date as
_____, 20____.

PORT: **CITY AND COUNTY OF SAN FRANCISCO**,
a municipal corporation, operating by and through the
SAN FRANCISCO PORT COMMISSION

By: _____
Rebecca Benassini
Deputy Director, Real Estate and Development

Date Signed: _____

Tenant:

By: _____
Name: _____
Title: _____

Date Signed: _____

EXHIBIT C

TENANT ESTOPPEL CERTIFICATE

The undersigned, _____, is the tenant of a portion of the real property commonly known as [Insert Premises Address] located in San Francisco, California (the "**Property**"), and hereby certifies to **THE CITY AND COUNTY OF SAN FRANCISCO THROUGH THE SAN FRANCISCO PORT COMMISSION ("Port")** [and to _____ ("**Developer/Lender**")] the following:

1. That there is presently in full force and effect a lease (as modified, assigned, supplemented and/or amended as set forth in paragraph 2 below, the "Lease") dated as of _____, 20__, between the undersigned and Port, covering approximately ____ square feet of the Property (the "**Premises**").

2. That the Lease has not been modified, assigned, supplemented or amended except by:

3. That the Lease represents the entire agreement between Port and the undersigned with respect to the Premises.

4. That the commencement date under the Lease was _____, 20__, the expiration date of said Lease is _____, 20__.

5. That the present minimum monthly Base Rent which the undersigned is paying under the Lease is \$_____.

6. The security deposit held by Port under the terms of the Lease is \$_____ and Port holds no other deposit from Tenant for security or otherwise.

7. That the undersigned has accepted possession of the Premises and that, to the best of the undersigned's knowledge, any improvements required to be made by Port to the Premises by the terms of the Lease and all other conditions of the Lease to be satisfied by Port have been completed or satisfied to the satisfaction of the undersigned.

8. That, to the best of the undersigned's knowledge, the undersigned, as of the date set forth below, has no right or claim of deduction, charge, lien or offset against Port under the Lease or otherwise against the rents or other charges due or to become due pursuant to the terms of the Lease.

9. That, to the best of the undersigned's knowledge, Port is not in default or breach of the Lease, nor has Port committed an act or failed to act in such a manner, which, with the passage of time or notice or both, would result in a default or breach of the Lease by Port.

10. That, to the best of the undersigned's knowledge, the undersigned is not in default or in breach of the Lease, nor has the undersigned committed an act or failed to act in such a manner which, with the passage of time or notice or both, would result in a default or breach of the Lease by the undersigned.

11. The undersigned is not the subject of any pending bankruptcy, insolvency, debtor's relief, reorganization, receivership, or similar proceedings, nor the subject of a ruling with respect to any of the foregoing.

This Certificate shall be binding upon and inure to the benefit of the undersigned, Port, [Developer/Lender] and [its/their respective] successors and assigns.

Dated: _____, 20__.

[Name of Tenant]

By:

Name:

Title:

EXHIBIT D
SUMMARY OF SECRETARY OF THE INTERIOR'S STANDARDS
FOR THE TREATMENT OF HISTORIC PROPERTIES

1. A property will be used as it was historically or be given a new use that requires minimal change to its distinctive materials, features, spaces, and spatial relationships.

2. The historic character of a property will be retained and preserved. The removal of distinctive materials or alteration of features, spaces, and spatial relationships that characterize a property will be avoided.

3. Each property will be recognized as a physical record of its time, place, and use. Changes that create a false sense of historical development, such as adding conjectural features or elements from other historic properties, will not be undertaken.

4. Changes to a property that have acquired historic significance in their own right will be retained and preserved.

5. Distinctive materials, features, finishes, and construction techniques or examples of craftsmanship that characterize a property will be preserved.

6. Deteriorated historic features will be repaired rather than replaced. Where the severity of deterioration requires replacement of a distinctive feature, the new feature will match the old in design, color, texture, and, where possible, materials. Replacement of missing features will be substantiated by documentary and physical evidence.

7. Chemical or physical treatments, if appropriate, will be undertaken using the gentlest means possible. Treatments that cause damage to historic materials will not be used.

8. Archeological resources will be protected and preserved in place. If such resources must be disturbed, mitigation measures will be undertaken.

9. New additions, exterior alterations, or related new construction will not destroy historic materials, features, and spatial relationships that characterize the property. The new work shall be differentiated from the old and will be compatible with the historic materials, features, size, scale and proportion, and massing to protect the integrity of the property and its environment.

10. New additions and adjacent or related new construction will be undertaken in such a manner that, if removed in the future, the essential form and integrity of the historic property and its environment would be unimpaired.

Initial :

Port: _____

Tenant: _____

DS
SF

[PAGE INTENTIONALLY LEFT BLANK]

EXHIBIT E

PORT OF SAN FRANCISCO HISTORIC PRESERVATION REVIEW GUIDELINES FOR PIER AND BULKHEAD WHARF SUBSTRUCTURES

Approved by San Francisco Port Commission, October 26, 2004, with proposed amendments to respond to comments from California State Office of Historic Preservation.

Background

As part of the preparation of the Port of San Francisco Embarcadero Historic District nomination, the Port has developed Historic Preservation Review Guidelines (Guidelines) to define how the Secretary of the Interior's Standards for Rehabilitation (Secretary's Standards) should be interpreted and applied to the historic resources within the District, to ensure its responsible management and stewardship. The set of Guidelines below focuses on Pier and Bulkhead Wharf Substructures, providing an important tool to be used by the Port's historic preservation experts to define parameters for the repair, maintenance or alterations to the pile foundations, substructures and decks of piers and bulkhead wharves upon which pier sheds, bulkhead buildings and other waterfront structures sit.

These Guidelines were developed by the Port's historic preservation expert staff in concert with San Francisco Architectural Heritage and preservation experts familiar with the specific historic resources in the District. The Guidelines were approved by the San Francisco Port Commission in October 2004, and further amended to respond to comments from the California State Office of Historic Preservation. The Guidelines will be used in the review of pier and bulkhead wharf substructure projects that are subject only to approval by the Port. Projects affecting District resources which are subject to review and approval by any of the following entities are not subject to these Guidelines, in recognition of the separate review criteria and practices employed by those agencies to administer the Secretary's Standards:

- 1) Federal Undertakings - Requiring Section 106 consultation
 - Projects receiving federal funding
 - Transfer of federal property
 - Approval of a federal permit, license or similar entitlement (i.e. Army Corps. of Engineers)
- 2) Federal Historic Preservation Tax Credit Projects – Requiring State Office of Historic Preservation and National Park Service approvals
- 3) San Francisco Historic Preservation Commission – Subject to Planning Code Article 10 Provisions for City Landmarks and City Historic Districts

Port of San Francisco Review Process – Overview

For projects affecting historic resources within the Embarcadero Historic District that are subject only to the Port's review and approval, the Port conducts its review in conjunction with use of Historic Preservation Guidelines, where applicable, to direct actions that comply with the Secretary's Standards.

All projects undergo case-specific review to determine the appropriate application of the Guidelines and other related Port design reviews. The Port maintains qualified historic preservation expertise on staff and may work with other qualified historic preservation professionals to review projects for consistency with the Secretary's Standards and any applicable Guidelines.

In the case of repairing and managing pier and bulkhead wharf substructures, the Guidelines below are to be used in the Port review process. The process follows the principles of the Secretary's Standards for Rehabilitation and the Port's longstanding practice of repairing existing materials wherever feasible. Replacement of historic materials, if deterioration makes such repair infeasible, is limited to replacement in-kind (use of the same materials) whenever possible. Where replacement in-kind is infeasible, the Port directs use of new substitute materials that are compatible with the character defining features of the subject historic resource to preserve the historic integrity of contributing resources or, in the case of reviewing non-contributing resources, the integrity of the Historic District.

Pier and Bulkhead Wharf Substructures

The historic piers and resources in the Embarcadero Historic District are made up of pile-supported platforms upon which pier shed and bulkhead building structures were built to conduct maritime commerce. The substructure of the piers and bulkhead wharf, described in detail in Section 7 of the Embarcadero Historic District nomination, consists of vertically driven piles, topped by stringer and pile cap beams, which create the horizontal structural framework upon which pier decks rest. Beneath these structures, the tides of the San Francisco Bay ebb and flow. Pier substructures are defined to include pier aprons, which are constructed at the perimeter of piers, generally used to provide a pile-supported platform for ship berthing, an outdoor work area, and in more recent times a public access and recreation area. In most instances, pier aprons are constructed of wood and have a shorter life span, historically requiring more maintenance and repair than steel and concrete substructures.

Within this complex, the bulkhead wharf is an important feature. It is comprised of 23 individual sections that extend end to end throughout the historic district, adjacent and connected to the Seawall, which establishes the constructed edge of the waterfront between piers. In addition, the bulkhead wharf plays an important role in defining the Embarcadero's urban form, which supports maritime, public access and commercial recreation/retail functions.

Initial :

Port: _____

Tenant: _____



EXHIBIT F

Operations Plan

[Attachment on following page(s)]

[PAGE INTENTIONALLY LEFT BLANK]

Autodesk Pier 9 Operations Plan

October 12, 2015

Contents

1.0	INTRODUCTION	4
2.0	GENERAL OPERATIONS.....	4
2.1	KEY STAFF AT PIER 9.....	4
2.2	KEY LOCATIONS AND ACTIVITIES.....	5
2.3	USE OF PORT FACILITIES-PROTECTING THE BAY.....	5
3.0	DESCRIPTION OF OPERATIONS	6
3.1	3D PRINTING.....	7
3.2	CNC SHOP OPERATIONS	10
3.3	GENERAL WORKSHOP OPERATIONS.....	13
3.4	TEXTILE ROOM OPERATIONS	17
3.5	ELECTRONICS LAB OPERATIONS.....	17
3.6	SECURED WASTE AREA OPERATIONS	17
3.7	OFFICE OPERATIONS.....	20
3.8	LIFESCIENCE WORKROOM	20
3.9	RESIN LAB.....	24
3.10	TEST KITCHEN.....	26
3.11	APPLIED INNOVATION LAB	28
3.11	MARITIME ACTIVITY.....	30
4.0	REGULATORY/ PERMITS.....	34
4.1	CITY AND COUNTY OF SAN FRANCISCO	34
4.1	STATE OF CALIFORNIA	34
4.2	FEDERAL	35
5.0	APPENDIX.....	36
5.1	SUMMARY OF BEST MANUFACTURING PRACTICES.....	36
5.2	APPENDIX B- SPILL RESPONSE.....	41
5.3	APPENDIX C- SELECT MARITIME RULES AND REGULATIONS.....	43
5.4	APPENDIX D-RULES AND REGULATIONS FOR OFFICE BUILDINGS.....	44
5.5	APPENDIX E-SELECT PERMITTED & REGULATED ACTIVITY (SUMMARY TABLE).....	49
5.6	APPENDIX F- AUTODESK SITE MAP.....	50
5.7	AUTODESK CHEMICAL INVENTORY	51
5.8	APPENDIX H- INDUSTRIAL STORM WATER POLLUTION PREVENTION PLAN	71

5.9	APPENDIX I- DEFINATIONS.....	72
5.10	APPENDIX J- WASTE PLAN (GROUND FLOOR)	73
5.11	APPENDIX K- STORAGE PLAN	75
5.12	APPENDIX L- SUPPLIES AND D ELIVERY PLAN	76
5.13	APPENDIX M-VEOLIA EMERGENCY RESPONSE PLAN	77
5.14	APPENDIX N- PERMITS	78
5.15	APPENDIX O- EQUIPMENT INVENTORY.....	79

1.0 INTRODUCTION

This Operations Plan provides the Environmental Requirements as referenced in the Lease for Autodesk, Inc., and governs all operations and activities undertaken by the Autodesk, Inc., (“Tenant”), and all of their Agents and Invitees conducting activities on Port venues. The Operations Plan identifies activities that will, subject to the Permitted Uses allowed by the relevant Lease. The Operations Plan sets forth the Port's environmental requirements, followed by a description of the major operations, which occur at the Pier 9 location. With each operation, protocols are discussed and then distilled into a series of Best Management Practices or BMPs. Following this is a review of the major regulatory requirements that pertain to the Tenant’s operations. Last is a series of appendices that includes a consolidation of operational BMPs, pertinent Port Rules and Regulations and additional supporting documents. In the event of any conflict between the provisions of this Operations Plan and the relevant Lease, the terms and provisions of the Lease shall prevail.

Definitions used in this Operations Plan, are found in the specified locations in this Operations Plan or are set forth in Appendix I. Other capitalized terms are defined in the relevant Lease or Venue License.

2.0 GENERAL OPERATIONS

2.1 KEY STAFF AT PIER 9

In the event of an emergency, the following are the key site contacts for Autodesk, Inc.:

TABLE 1: Key Staff

NAME	TITLE	PHONE	EMAIL
Jake Saltzman	Regional Facilities Manager	(415) 5803418	Jake.Saltzman@autodesk.com
Julia Cabral	Global EH&S Manager	(510) 552 3698	Julia.Cabral@autodesk.com
Aileen Gaffney	Regional EH&S Manager	(415) 583 5695	Aileen.Gaffney@autodesk.com
Autodesk Security	24/7 Security Operations Center	(415) 507 5555	Security@autodesk.com
Kathy Clinton	Geo Facilities Manager	(415) 507 6605	Kathy.Clinton@autodesk.com
Dave Ego	Global Security Manager	(415) 507 6526	David.Ego@autodesk.com

2.2 KEY LOCATIONS AND ACTIVITIES

The following table lists locations and the activities that are currently in place or planned for Autodesk, Inc. operations at the Pier 9 site.

TABLE 2: Locations and Activities

LOCATION	ACTIVITIES
Suite 116	1 st Floor: Multi-Function Space, Restrooms, HA Lift 2 nd Floor: Project Room, Electronics Lab, Server Room
Bay #1	1 st Floor: CNC Shop 2 nd Floor: Catwalk
Bay #2	1 st Floor: Wood Shop 2 nd Floor: Print Shop
Bay #3	1 st Floor: Metal Shop 2 nd Floor: Print Shop
Suite 102	1 st Floor: Office Area and Life Sciences Workroom
Suites 106/108/110	1 st Floor: Reception, Office Area, Break Room 2 nd Floor: Office Area
Suite 114	1 st Floor: Storage and Test Kitchen 2 nd Floor: Office Area
Bay #4 and #5	Projects Assembly Room and Robotics Lab
Adjacent to Bay #5	Secured Waste Area
Adjacent to Bay #1	Studio 9: Office Area, Restrooms, Break Room (2 floors)
Across from secured waste area	Secured wood and material storage area

The activities and venues described above are illustrative and not exclusive and are subject to change as provided in the Venue Lease.

2.3 USE OF PORT FACILITIES-PROTECTING THE BAY

Most Port piers and the structures on them drain to the San Francisco Bay. Therefore, materials that are released on pier aprons or inside pier sheds could ultimately be released into the Bay. Materials can also be conveyed to the Bay by storm water or wind. Even materials that are spilled in the dry summer months can be washed into the Bay with the winter rains. None of Autodesk, Inc.'s activities will be on pier aprons and only inside pier sheds. Autodesk, Inc. will ensure all waste water is directed into sanitary waste system.

TABLE 3: Pollutants and Activities of Concern

POLLUTANTS	ACTIVITIES OF CONCERN
Trash / Debris	Waste Management
Vehicle Fluids	Parking, Deliveries/Provisioning,
Equipment Fluids	Operation of plant forklift equipment
Hazardous Materials	Shop Activities

The two most important Best Management Practice (BMP) when using Port facilities are:

- 1) Be aware of the potential to pollute the Bay.
- 2) Train staff to protect the Bay.

The following Best Management Practices (BMPs) shall be used at all times.

BMPs-General Use of Port Facilities

- **BE AWARE:** Be aware of the potential to pollute the Bay
- **TRAIN STAFF:** Train staff to be partners in protecting the Bay
- **DEBRIS MANAGEMENT:** Place trash and debris in the proper containers
- **END OF DAY CLEAN-UP:** At the end of the day or when activities are over, conduct a general clean up to remove debris, trash and inspect for spills
- **SWEEP:** Use dry cleaning methods rather than pressure washing surfaces
- **CLEAN SPILLS IMMEDIATELY:** Keep equipment clean. Avoid excessive build-up of oil and grease.

3.0 DESCRIPTION OF OPERATIONS

GENERAL

This section describes the Tenant's operations and activities that are authorized at Pier 9. These operations and activities include general office use and various workshop uses, as more particularly described in the operations section below. These operations and activities shall be conducted in accordance with this Operations Plan.

If the Tenant would like to conduct new activities and operations, it shall submit a revised Operations Plan to the Port for approval. A revised Operations Plan shall specify at a minimum:

- proposed new activities,
- additional venues for activities approved elsewhere,
- new permit requirements (new permits and modifications to existing permits);
- BMPs that will be employed.
- Other information reasonably required by Port.

The Port will respond promptly to any revised Operations Plan and, in case of disapproval, shall specify in detail the changes to the revised Operations Plan needed to gain Port's approval.

3.1 3D PRINTING

Print Shop operations are carried out in the 3D Print Shop and the 3D Project Room. These include various model making activities using specialty model making machines as well as hand model making processes. Types of model making in this workshop are:

- 1. 3D Print Machines:** Specialty print machines used to fabricate three dimensional models using ultraviolet (UV) light and cured resins.
- 2. Laser Cutters:** Specialty cutters used to fabricate three dimensional models. Laser cutters are fully enclosed units with interlocked access door. Materials used are wood, metals, acrylics, and cardboard.
- 3. Model Making Room:** Models made by hand by mixing two-part rubbers and silicones into molds. Materials used are non-flammable and food and skin safe.

Other equipment in this workshop include a model washing station, (an enclosed cabinet used to wash the support material off of the 3-D model), an enclosed cabinet to store resin cartridges, a pallet rack used to store material for cutting on laser cutters, cleaning station, water bath and a front loader Energy Star rated washer and dryer used to support the sewing projects in the Project Room.

Common activities associated with 3-D printing and laser cutting are:

- Loading computer program into machines (3-D print or laser cutter)
- Loading desired print material (resin) into 3-D machine
- Loading desired material for cutting or engraving into laser cutter
- Washing 3-D printed models to remove support material

Common industrial activities associated with 3-D printing and laser cutting are:

- Tools and Equipment Storage
- Hazardous Materials Storage
- Hazardous Materials Waste Removal (used liquid resin)
- Cutting/Engraving

TOOLS / EQUIPMENT: STORAGE AND USE FOR PRINT SHOP

Routine maintenance of the laser equipment includes general cleaning (vacuum/wipe down of the cutter area and cleaning mirrors and lenses with isopropyl alcohol (IPA). All other service or repair is performed by the manufacturer. Routine maintenance for the 3-D printers includes cleaning spray heads with 91% IPA after each job and removing and cleaning the roller with IPA

every month. Equipment service and repairs, including changing of carbon filters are done by the manufacturer.

Secondary Containment

Resins for the 3-D print machines will be stored in a separated resin storage area.

Maintenance Areas

All maintenance areas shall have an appropriate spill kit available.

The following Best Management Practices (BMPs) shall be used for the storage and use of tools and equipment.

BMPs– Storage and Use of Tools and Equipment for Print Shop

- **KEEP CLEAN:** Keep tools and equipment clean.
- **RESIN CARTRIDGES:** Properly store in resin storage area.
- **COMPRESSED GAS:** Canisters are secured to wall or equipment cart at all times.
- **FUME EXTRACTION:** Employ fume extraction with either high pressure extractor or low pressure blowers where equipment use requires ventilation
- **CATCH DRIPS:** Place absorbent pads or drip pans under equipment that contains fluids.
- **INSPECT EQUIPMENT:** Inspect equipment weekly for leaks and needed repairs.
- **CLEAN SPILLS IMMEDIATELY:** Clean spill immediately and completely. If absorbent materials are used, they must be removed and disposed promptly.
- **SPILL KIT:** Keep a properly sized spill kit in all areas with the potential for leaks.

MATERIALS MANAGEMENT FOR PRINT SHOP

Hazardous Materials as well as non-Hazardous Materials will be used in the Print Shop. All materials must be stored in accordance with regulatory requirements and permit conditions.

DESIGNATED AREA

All materials should be stored in specific areas with signs that designate them as materials storage. Incompatible materials such as corrosives and flammables should be segregated. Empty containers should be identified and stored separately.

Recyclable materials, compostable materials, and landfill waste shall be separated and stored in designated areas. Each area shall have clear signage.

SECONDARY CONTAINMENT

All Hazardous Materials must be stored with proper secondary containment. Absorbent pads are an inexpensive and effective management tool. All used resin

containers shall be stored on secondary containment pallets. All empty resin cartridges shall be disposed of as hazardous waste.

SPILLS

Spills and drips around Hazardous Materials storage areas shall be cleaned up immediately. Appropriate spill kits shall be kept at all areas where Hazardous Materials are stored. When absorbent material is used, it shall be promptly removed and properly disposed.

LABELS

All materials storage containers shall be properly labeled. All containers shall be stored so that the labels are visible. Any hazardous waste that is generated shall be immediately and properly labeled. Empty containers should be so designated.

SPILL KITS

The purpose of the spill kit is to be prepared to clean up liquid releases of Hazardous Materials such as hydraulic oil and motor oil from parked trucks and vehicles or paints, solvents, or fuels. Burst hydraulic lines are a common source of pollution from heavy vehicles.

Spill Kit Contents

- Absorbent spill pads and socks.
- Absorbent material (e.g. solvent absorbent, vermiculite, etc.)
- Hydrophobic mop (i.e. a mop that absorbs oil, but not water)
- Safety gloves (that are appropriate for oils, and other petroleum)
- 5 – 20 gallon bucket/drum with lid
- Hazardous Waste Labels

The following Best Management Practices (BMPs) shall be used for the storage and use of materials.

BMPs– Materials Management for Print Shop

- **MATERIALS STORAGE AREAS:** Designate areas for storage of specific materials;
- **SECONDARY CONTAINMENT:** Store all materials with secondary containment;
- **DISPENSER CONTAINMENT:** Use secondary containment with drip reservoirs for dispensers;
- **COMPRESSED GAS:** Canisters are secured to wall or equipment cart at all times;
- **CATCH DRIPS:** Place absorbent pads or drip pans under equipment that contains fluids;

- **CLEAN SPILLS IMMEDIATELY:** Clean spill immediately and completely. If absorbent materials are used, they should be removed and disposed promptly;
- **SPILL KIT:** Keep a properly sized spill kit in all areas with the potential for leaks;
- **LABELS:** Properly label all materials;
- **WASTE AREAS:** Waste materials will be removed to secured waste collection area.

3.2 CNC SHOP OPERATIONS

Specialty fabricating equipment using CNC technology to make models and designs developed using Autodesk design software. All fabricating equipment is fully enclosed, self-contained units. Types of machines used in this workshop are; CNC lathes, CNC mills, Water-jet and 5-Axis router.

Common activities associated with CNC machines are:

- Uploading design into CNC machine
- Loading desired material for CNC fabricating
- Monitoring fabricating process

Common industrial activities associated with CNC machines are:

- Tools and Equipment Storage
- Raw Materials Storage
- Raw Materials Recycling
- Maintaining coolant levels of machines
- Lubricating machines

Common activities associated with Water Jet are:

- Uploading design into Water Jet
- Loading desired material for CNC fabricating
- Monitoring fabricating process

Common industrial activities associated with Water Jet are:

- Cleaning of Water Jet
- 2-3 times a year pumping of water jet sump

Common Activities of 5-Axis Router are:

- Uploading design into router
- Loading desired material for CNC fabricating

- Monitoring fabricating process

Common Industrial Activities of 5-Axis Router are:

- Lubricating and belt changing annually

TOOLS / EQUIPMENT: STORAGE AND USE FOR CNC SHOP

Routine maintenance of the CNC equipment includes general cleaning, maintaining coolant levels, and lubricating. All other service or repair is performed by the manufacturer. Routine maintenance of the Water Jet includes general cleaning after every use and bi-annual pumping of the water jet sump. All other service or repair is performed by the manufacturer.

MAINTENANCE AREAS

All maintenance areas shall have an appropriate spill kit available. All maintenance areas shall have an appropriate maintenance kit, including pumps, drip pans and collection and discharge equipment.

The following Best Management Practices (BMPs) shall be used for the storage and use of tools and equipment.

BMPs– Storage and Use of Tools and Equipment for CNC Shop

- **KEEP CLEAN:** Keep tools and equipment clean.
- **FLAMMABLES CONTAINER:** Properly store flammables in flammables cabinet.
- **DUST COLLECTION:** Employ dust collection system were equipment use creates dust.
- **SECONDARY CONTAINMENT:** Place absorbent pads or drip pans under equipment that contains fluids.
- **INSPECT EQUIPMENT:** Inspect equipment weekly for leaks and needed repairs.
- **CLEAN SPILLS IMMEDIATELY:** Clean spill immediately and completely. If absorbent materials are used, they must be removed and disposed promptly.
- **SPILL KIT:** Keep a properly sized spill kit in all areas with the potential for leaks.

MATERIALS MANAGEMENT FOR CNC SHOP

Hazardous Materials as well as non-Hazardous Materials will be used in the CNC Shop. These cutting oils, coolants, and lubricant materials must be stored in flammable cabinets that can be secured. All materials must be stored in accordance with regulatory requirements and permit conditions.

DESIGNATED AREAS

All materials should be stored in specific areas with signs that designate them as materials storage. Incompatible materials such as corrosives and flammables should be segregated. Empty containers should be identified and stored separately.

Recyclable materials, compostable materials, and landfill waste shall be separated and stored in designated areas. Each area shall have clear signage.

SECONDARY CONTAINMENT

All Hazardous Materials must be stored with proper secondary containment. Absorbent pads are an inexpensive and effective management tool. All used coolant will be changed on a bi-annual basis. CNC machine coolants are housed within secondary containment inside all CNC machines.

LABELS

All materials storage containers shall be properly labeled. All containers shall be stored so that the labels are visible. Any hazardous waste that is generated shall be immediately and properly labeled. Empty containers should be so designated.

SPILLS

Spills and drips around hazardous materials storage areas shall be cleaned up immediately. Appropriate spill kits shall be kept at all areas where hazardous materials are stored. When absorbent material is used it shall be promptly removed and properly disposed.

SPILL KITS

The purpose of the spill kit is to be prepared to clean up liquid releases of Hazardous Materials such as hydraulic oil and motor oil from parked trucks and vehicles or paints, solvents, or fuels. Burst hydraulic lines are a common source of pollution from heavy vehicles.

Spill Kit Contents:

- Absorbent spill pads and socks.
- Absorbent material (e.g. solvent absorbent, vermiculite, etc.)
- Hydrophobic mop (i.e. a mop that absorbs oil, but not water)
- Safety gloves (that are appropriate for oils, and other petroleum)
- 5 – 20 gallon bucket/drum with lid
- Hazardous Waste Labels

The following Best Management Practices (BMPs) shall be used for the storage and use of materials.

BMPs– Materials Management CNC Shop

- **MATERIALS STORAGE AREAS:** Designate areas for storage of specific materials;
- **SECONDARY CONTAINMENT:** Store all materials with secondary containment;
- **DISPENSER CONTAINMENT:** Use secondary containment with drip reservoirs for dispensers;
- **COMPRESSED GAS:** Canisters are secured to wall or equipment cart at all times;
- **CATCH DRIPS:** Place absorbent pads or drip pans under equipment that contains fluids;
- **CLEAN SPILLS IMMEDIATELY:** Clean spill immediately and completely. If absorbent materials are used, they should be removed and disposed promptly;
- **SPILL KIT:** Keep a properly sized spill kit in all areas with the potential for leaks;

3.3 GENERAL WORKSHOP OPERATIONS

This workshop is a general shop that incorporates a wood shop, metal shop, spray booth and project assembly room into Designated Areas.

DESIGNATED AREAS

Designating areas for specific activities is the best way to ensure that the activities are conducted safely and without generating pollution.

Equipment in each of these Designated Areas is as follows:

- 1. Wood Shop:** Wood lathe, drill press, oscillating spindle sander, disk sander, table saw, scroll saw, planer, circular saw, jointer, belt sander and band saw.
- 2. Metal Shop:** Belt sander, welding table, band saw, hydraulic bender, pedestal grinder, cold saw, tig welder, mig welder, band saw, hydraulic press, knee mill, manual lathe, and drill press.
- 3. Spray Booth:** Dedicated room for spray painting fabricated models.
- 4. Project Assembly Room:** Shopbot and air compressor to serve workshops.

CONTROLS

The activities associated with these designated areas will all be performed in contained, indoor areas. The following additional controls will be put in place:

- Vacuum containment for tools creating dust
- Dust collection system
- Spray booth containment with negative air system for spray painting activities

PROHIBITED ACTIVITIES

1. Conducting any shop activities outside of the Autodesk spaces
2. Transferring of any chemicals outside of the Autodesk spaces unless in proper secondary containment.

GENERAL HOUSEKEEPING

Good housekeeping by all personnel is one of the most effective strategies to prevent pollution. Key features of good housekeeping include:

- Clean spills immediately and completely.
- Putting away materials/tools when not in use.
- Using clear signs and labels for areas and materials.
- Clean all areas after use on a daily basis.

The following Best Management Practices (BMPs) shall be used for the storage and use of tools and equipment.

BMPs – General Shop Operations

- **CONTAIN ALL MATERIALS:** Use secondary containment;
- **DESIGNATED AREAS:** Designate specific areas for specific activities;
- **CONTROLS:** Use controls to contain materials indoors and separate from other indoor activities.
- **GENERAL HOUSEKEEPING:** Maintain general housekeeping by all staff.

TOOLS / EQUIPMENT: STORAGE AND USE FOR GENERAL SHOP OPERATIONS

A variety of tools and equipment will be used, from small hand tools to table saws. Most tools and equipment accumulate grease and other pollutants and require regular cleaning. Additionally, many types of equipment use fuels, oils, and hydraulic fluids. These require regular inspections and maintenance to stop leaks and prevent spills.

SECONDARY CONTAINMENT

Tools and equipment are commonly stored in containers that can be secured. However, these containers are not necessarily designed to contain liquids and do not provide adequate containment for leaks and spills. Absorbent pads, when placed under equipment reservoirs and hose connections, help to identify and contain leaks. For large equipment, drip pans are an effective and inexpensive alternative.

MAINTENANCE AREAS

Maintenance of equipment shall be conducted in specific areas that have signs that designate them as maintenance areas. All maintenance areas shall have an appropriate spill kit available.

The following Best Management Practices (BMPs) shall be used for the storage and use of tools and equipment.

BMPs– Storage and Use of Tools and Equipment for General Shop

- **KEEP CLEAN:** Keep tools clean and free of excessive grease and grime.
- **TOOL CONTAINER:** Properly store when not in use. Do not leave tools lying around. Store under cover.
- **FLAMMABLES CONTAINER:** Properly store flammables in flammables cabinet.
- **DUST COLLECTION:** Employ dust collection system where equipment use creates dust.
- **FUME EXTRACTION:** Employ fume extraction with either high pressure extractor or low pressure blowers where equipment use requires ventilation
- **COMPRESSED GAS:** Canisters are secured to wall or equipment cart at all times.
- **CATCH DRIPS:** Place absorbent pads or drip pans under equipment that contains fluids.
- **INSPECT EQUIPMENT:** Inspect equipment weekly for leaks and needed repairs.
- **CLEAN SPILLS IMMEDIATELY:** Clean spill immediately and completely. If absorbent materials are used, they must be removed and disposed promptly.
- **SPILL KIT:** Keep a properly sized spill kit in all areas with the potential for leaks.
- **WASTE AREAS:** Waste materials will be removed to secured waste collection area.

MATERIALS MANAGEMENT GENERAL SHOP

Hazardous Materials as well as non-Hazardous Materials will be used in the General Shop. These coolants, lubricants, cutting oils, acetone, solvents, and paint materials must be stored in flammable cabinets that can be secured. All materials must be stored in accordance with regulatory requirements and permit conditions.

DESIGNATED AREAS

All materials should be stored in specific areas with signs that designate them as materials storage. Incompatible materials such as corrosives and flammables should be segregated. Empty containers should be identified and stored separately. Recyclable materials, compostable materials, and landfill waste shall be separated and stored in designated areas. Each area shall have clear signage.

SECONDARY CONTAINMENT

All Hazardous Materials must be stored with proper secondary containment. Absorbent pads are an inexpensive and effective management tool. All used coolant will be changed on a bi-annual basis. Machine coolants are housed within secondary containment inside all machines. All paints and varnishes are stored inside flammable cabinet located in woodshop or metal shop.

SPILLS

Spills and drips around Hazardous Materials storage areas shall be cleaned up

immediately. Appropriate spill kits shall be kept at all areas where Hazardous Materials are stored. When absorbent material is used, it shall be promptly removed and properly disposed.

LABELS

All materials storage containers shall be properly labeled. All containers shall be stored so that the labels are visible. Any hazardous waste that is generated shall be immediately and properly labeled. Empty containers should be so designated.

SPILL KITS

The purpose of the spill kit is to be prepared to clean up liquid releases of Hazardous Materials such as hydraulic oil and motor oil from parked trucks and vehicles or paints, solvents, or fuels. Burst hydraulic lines are a common source of pollution from heavy vehicles.

Spill Kit Contents

- Absorbent spill pads and socks.
- Absorbent material (e.g. solvent absorbent, vermiculite, etc.)
- Hydrophobic mop (i.e. a mop that absorbs oil, but not water)
- Safety gloves (that are appropriate for oils, and other petroleum)
- 5 – 20 gallon bucket/drum with lid
- Hazardous Waste Labels

The following Best Management Practices (BMPs) shall be used for the storage and use of materials:

BMPs– Materials Management General Shop

- **MATERIALS STORAGE AREAS:** Designate areas for storage of specific materials.
- **SECONDARY CONTAINMENT:** Store all materials with secondary containment.
- **DISPENSER CONTAINMENT:** Use secondary containment with drip reservoirs for dispensers.
- **COMPRESSED GAS:** Canisters are secured to wall or equipment cart at all times.
- **CATCH DRIPS:** Place absorbent pads or drip pans under equipment that contains fluids.
- **CLEAN SPILLS IMMEDIATELY:** Clean spill immediately and completely. If absorbent materials are used, they should be removed and disposed promptly.
- **SPILL KIT:** Keep a properly sized spill kit in all areas with the potential for leaks.

3.4 TEXTILE ROOM OPERATIONS

This workshop is a general workroom for crafts and sewing projects. Equipment in this workshop is a commercial steam generator with ironing board, walking machine (sewing), Serger machine (sewing), table top UV exposure unit, one color shirt press, standard dress form, complete heating system plastic bender and 3D makerbots. A washer and dryer will be used to support sewing projects. (Washer and dryer location shall be in the Model Making room.) We do not foresee any unique waste from this workroom.

BMPs-Textile Room

- **CLEAN AREA:** Maintain area in an orderly manner at all times.
- **INSPECT EQUIPMENT:** Inspect equipment prior to each use for defective parts, etc.
- **TOOL CONTAINER:** Items must be properly stored away at all times.
- **TEXTILES MATERIALS:** Recycle all material as far as reasonably practicable.

3.5 ELECTRONICS LAB OPERATIONS

This workshop is a workroom for bench top electronics projects. Equipment in this workshop includes power supply, signal generator, spectrum analyzer, oscilloscope, and logic analyzer. Workroom will require minimal fume extraction. There is a container for waste electronic devices available in this workroom for proper disposal of regulated items.

BMPs-Electronics Lab

- **CLEAN AREA:** Ensure area is maintained and kept clear from unnecessary items.
- **INSPECT EQUIPMENT:** Inspect equipment prior to each use for defective parts, etc.
- **RECYCLE:** Ensure all e-waste is recycled correctly.
- **MATERIALS:** Ensure lead free solder is used at all times.

3.6 SECURED WASTE AREA OPERATIONS

This area is a secured waste area adjacent to the Applied Innovation Lab. It is a fenced in area, with a gate, security camera, and lock. The secured trash area is used to house and charge the electronic forklift serving the workshops, bulk metal recycling bins, gas cylinder cage, hazardous materials, hazardous waste, and universal waste. The gas cylinder cage is for empty cylinders, and all cylinders are secured to the wall or fencing.

MISCELLEANEOUS FUELING

Re-charging of the electric forklift will take place on a nightly basis or when required. Charging station will be in the secured waste area, where the forklift will be parked overnight. The Forklift battery is a lead acid type, and all maintenance of the forklift shall be performed by a 3-party forklift maintenance company

TOOLS / EQUIPMENT: STORAGE AND USE FOR SECURED WASTE AREA

A variety of tools and equipment will be used, from small hand tools to large machines, to electric forklift. Most tools and equipment accumulate grease and other pollutants and require regular cleaning. Additionally, many types of equipment use fuels, oils, and hydraulic fluids. These require regular inspections and maintenance to stop leaks and prevent spills.

SECONDARY CONTAINMENT

Tools and equipment are commonly stored in containers that can be secured. However, these containers are not necessarily designed to contain liquids and do not provide adequate containment for leaks and spills. Absorbent pads, when placed under equipment reservoirs and hose connections, help to identify and contain leaks. For large equipment, drip pans are an effective and inexpensive alternative.

MAINTENANCE AREAS

Maintenance of equipment shall be conducted in specific areas that have signs that designate them as maintenance areas. All maintenance areas shall have an appropriate spill kit available.

The following Best Management Practices (BMPs) shall be used for the storage and use of tools and equipment.

BMPs– Storage and Use of Tools and Equipment for Secured Waste Area

- **KEEP CLEAN:** Keep tools clean and free of excessive grease and grime.
- **TOOL CONTAINER:** Properly store when not in use. Do not leave tools lying around. Store under cover.
- **CATCH DRIPS:** Place absorbent pads or drip pans under equipment that contains fluids.
- **INSPECT EQUIPMENT:** Inspect equipment weekly for leaks and needed repairs.
- **CLEAN SPILLS IMMEDIATELY:** Clean spill immediately and completely. If absorbent materials are used, they must be removed and disposed promptly.
- **SPILL KIT:** Keep a properly sized spill kit in all areas with the potential for leaks.
-

MATERIALS MANAGEMENT FOR SECURED WASTE AREA

Hazardous Materials Products as well as hazardous waste will be stored in the secure waste area. All materials must be stored in accordance with regulatory requirements and permit conditions.

DESIGNATED AREAS

All materials should be stored in specific areas with signs that designate them as materials storage. Incompatible materials such as corrosives and flammables should be segregated. Empty containers should be identified and stored separately. Hazardous material products, Hazardous Waste, and Universal Waste shall be separated and stored in designated areas. Each area shall have clear signage.

SECONDARY CONTAINMENT

All Hazardous Materials must be stored with proper secondary containment. Absorbent pads are an inexpensive and effective management tool. All hazardous waste stored in the secured waste storage area shall be picked up at least every 180 days.

SPILLS

Spills and drips around Hazardous Materials storage areas shall be cleaned up immediately. Appropriate spill kits shall be kept at all areas where Hazardous Materials are stored. When absorbent material is used, it shall be promptly removed and properly disposed.

LABELS

All materials storage containers shall be properly labeled. All containers shall be stored so that the labels are visible. Any hazardous waste that is generated shall be immediately and properly labeled. Empty containers should be so designated.

SPILL KITS

The purpose of the spill kit is to be prepared to clean up liquid releases of Hazardous Materials such as coolant, paints, solvents, or fuels. Burst hydraulic lines are a common source of pollution from heavy vehicles.

Spill Kit Contents

- Absorbent spill pads and socks.
- Absorbent material (e.g. solvent absorbent, vermiculite, etc.)
- Hydrophobic mop (i.e. a mop that absorbs oil, but not water)
- Safety gloves (that are appropriate for oils, and other petroleum)
- 5 – 20 gallon bucket/drum with lid
- Hazardous Waste Labels

The following Best Management Practices (BMPs) shall be used for the storage and use of materials.

BMPs– Materials Management for Secured Waste Area

- **MATERIALS STORAGE AREAS:** Designate areas for storage of specific materials;
- **SECONDARY CONTAINMENT:** Store all materials with secondary containment;
- **DISPENSER CONTAINMENT:** Use secondary containment with drip reservoirs for dispensers;
- **COMPRESSED GAS:** Canisters are secured to wall or fencing at all times;
- **CATCH DRIPS:** Place absorbent pads or drip pans under equipment that contains fluids;
- **CLEAN SPILLS IMMEDIATELY:** Clean spill immediately and completely. If absorbent materials are used, they should be removed and disposed promptly;
- **SPILL KIT:** Keep a properly sized spill kit in all areas with the potential for leaks;
- **LABELS:** Properly label all materials;

3.7 OFFICE OPERATIONS

A portion of Autodesk’s Pier 9 facilities will be used as multi-functional office space or related uses by Tenant. Use of these facilities for these purposes shall be subject to the Port’s Rules and Regulations for Office Buildings (see Appendix D). An office space opposite the middle entrance to Pier 9 also belongs to Autodesk-Studio 9 (see Appendix F).

3.8 LIFESCIENCE WORKROOM

This workroom is a workroom that supports general molecular biology work, new process development, automation development (for example, incorporating microfluidic systems and laboratory robots into workflows), and educational workshops and demonstrations. The workroom will be a hands-on place for Autodesk employees to familiarize themselves with the basics of biotechnology and nanotechnology, and for the creation and use of tools, materials, and processes aimed at the strategic goal of democratizing life science and molecular manipulation.

The general molecular biology work that will be done in the Life Science Workroom will include;

- DNA sample preparation
- DNA sequencing
- DNA sample preparations
- DNA nanoparticle preparations
- DNA separation and quantification
- DNA amplification using PCR
- Restriction digests
- Electron Microscopy
- Fungal cell culturing (mushroom mycelium)
- Atomic force microscopy
- Computed aided design of DNA
- Simulation and visualization of molecular systems

CONTROLS

The activities associated with the Life Science Workroom will be performed in a contained, secured, indoor workroom. The following additional controls will be put in place:

- All mixing of biohazardous materials which can generate aerosols will be done under the bio safety cabinet
- Card reader controlled access (only authorized users will have access)
- All biohazardous waste segregated in proper waste containers and disposed of by a licensed 3rd party bio waste vendor.

PROHIBITED ACTIVITIES

- Conducting any Life Science Workroom activity outside of Life Science Workroom
- Transferring of any chemicals outside of Life Science Workroom without proper secondary containment
- No discarding of organisms or transferring organisms outside of Life Science Workroom without autoclaving such organisms first or handling as bio waste
- No food or drink in Life Science Workroom and no food storage allowed in Life Science Workroom refrigerators or freezer.

GENERAL HOUSEKEEPING

Good housekeeping by all personnel is one of the most effective strategies to prevent pollution. Key features of good housekeeping for the Life Science Workroom to include:

- Authorized users to keep room clean
- Dedicated cleaning tools and chemicals for Life Science Workroom
- Regular janitorial staff will not have access to Life Science Workroom
- Clean spills immediately and completely
- Putting away all materials/kits/reagents/tools when not in use
- Clean all areas after use on a daily basis

The following Best Management Practices (BMPs) shall be used for the Life Science Workroom.

- **CONTAIN ALL MATERIALS:** Keep all materials in Life Science Workroom
- **DESIGNATED AREA:** All Life Science Workroom activities shall be conducted only in the Life Science Workroom
- **CONTROLS:** Use controls to contain materials within Life Science Workroom and control access to only authorized users.
- **ADHERE TO PROHIBITIONS:** All employees working within the Life Science workroom shall receive Hepatitis B vaccine.
- **GENERAL HOUSEKEEPING:** Maintain daily cleaning after every use and cleaning to be performed only by authorized users with equipment and supplies dedicated to Life Science Workroom.

MATERIALS MANAGEMENT LIFE SCIENCE WORKROOM

Primarily non-Hazardous Materials will be used in the Life Science Workroom. Bleach will be used for cleaning the Life Science workroom. Any biological material will be stored in the -20 degree freezer. Reagents will be stored as appropriate DNA kits in Life Science Workroom cabinets. All materials must be stored in accordance with regulatory requirements and permit conditions.

DESIGNATED AREAS

All materials should be stored in specific areas with signs that designate them as materials storage. Incompatible materials such as acids and bases will be segregated, i.e., corrosives cabinet and flammables cabinet. Empty containers will be identified and stored separately. Recyclable materials, compostable materials, landfill and bio waste shall be separated and stored in designated areas. Each area shall have clear signage.

SECONDARY CONTAINMENT

All Hazardous Materials must be stored with proper secondary containment. Absorbent pads are an inexpensive and effective management tool. All used kits shall be autoclaved before entering regular trash waste stream.

SPILLS

Spills and drips shall be cleaned up immediately and deposited in bio waste containers. All bio waste will be handled by a licensed 3rd party vendor. Appropriate spill kits shall be kept in the Life Science Workroom. When absorbent material is used, it shall be promptly removed and properly disposed of.

LABELS

All materials storage containers shall be properly labeled. All containers shall be stored so that the labels are visible. Any hazardous waste that is generated shall be immediately and properly labeled. Empty containers should be so designated.

SPILL KITS

The purpose of the spill kit is to be prepared to clean up liquid releases of Hazardous Materials such as household bleach.

Spill Kit Contents

- Absorbent spill pads and socks

- Safety gloves (that are appropriate for lab use)
- 5 gallon bucket/drum with lid
- Hazardous waste labels

BMPs – Materials Management Life Science Workroom

- **MATERIALS STORAGE AREAS:** Designate areas for storage of specific materials
- **SECONDARY CONTAINMENT:** Store all materials with secondary containment
- **AUTOCLAVING:** Autoclaving will only be used for sterilizing tools. All bio waste will be handled and disposed of by a licensed 3rd party vendor.
- **CLEAN SPILLS IMMEDIATELY:** Clean spill immediately and completely. If absorbent materials are used, they should be removed and disposed of promptly.
- **SPILL KIT:** Keep a properly sized kit in all areas with the potential for leaks.

3.9 RESIN LAB

The Resin Lab is a chemist research lab mainly used for resin formulation. The lab will be a hands on place for Autodesk employees to familiarize themselves with the basics of chemistry, and for the creation and use of tools, materials, and processes aimed at prototype testing, surface modification and materials qualification.

DESIGNATED AREAS

All activities conducted inside the Resin Lab are conducted in a safe manner. Equipment in the Resin lab is as follows: fume hood, vortex mixer, lab oven, spin coater, chemical pump and hot plate stirrer.

CONTROLS

The activities associated with the Resin Lab will be performed in a contained, secured, indoor workroom. The following additional controls will be put in place.

- All mixing of chemical materials will be done under the fume hood
- Card reader controlled access (only authorized users will have access)
- All hazardous waste generated shall be segregated in proper waste containers and disposed of by a licensed 3rd party hazardous waste vendor.
- Safety glasses and lab coat required when inside the Resin Lab.

PROHIBITED ACTIVITIES

- Conducting any Resin lab activity outside of the Resin lab
- Transferring of any chemicals outside of Resin Lab without proper secondary containment.
- No discarding of chemicals or hazardous waste outside of the Resin lab under any circumstance.
- No food or drink in the Resin Lab.

GENERAL HOUSEKEEPING

Good housekeeping by all personnel is one of the most effective strategies in maintaining a safe workplace. Key features of good housekeeping for the Resin Lab include:

- Authorized users to keep room clean
- Dedicated cleaning tools and chemicals for Resin lab.
- Clean spills immediately and completely.
- Putting away all materials/kits/reagents/tools when not in use
- Clean all areas after use on a daily basis.

The following best management practice (BMPs) shall be used for the Resin Lab.

- **CONTAIN ALL MATERIALS:** Keep all materials in Resin Lab.
- **DESIGNATED AREA:** All Resin Lab activities shall be conducted only in the Resin lab.
- **CONTROLS:** Use controls to contain materials within the Resin Lab and control access to only authorized users.
- **ADHERE TO PROHIBITIONS:** All employees working within the Resin Lab must follow all safety policies and procedures.
- **GENERAL HOUSEKEEPING:** Maintain daily cleaning after every use and cleaning to be performed only by authorized users with equipment and supplies dedicated to Resin Lab.

MATERIALS MANAGEMENT- RESIN LAB

Hazardous materials will be used in the Resin Lab. All flammable material will be stored inside a flammables chemical cabinet. All corrosive materials will be stored inside the corrosives cabinet. All materials must be stored with permit conditions.

All chemicals are placed on the chemical inventory for the Resin Lab. (See appendix G)

DESIGNATED AREAS

All materials should be stored in specific areas with signs that designate them as materials storage. Incompatible materials such as acids and bases will be segregated, i.e., acids cabinet and corrosives cabinet. Empty containers will be identified and stored separately. No chemicals should be stored in the fume hood. There is a satellite accumulation point directly outside the Resin lab with clear signage indicating that it is satellite accumulation.

SECONDARY CONTAINMENT

All hazardous materials must be stored with proper secondary containment.

SPILLS

Spills and drips shall be cleaned up immediately and deposited into the satellite accumulation waste area. All hazardous waste will be handled by a licensed 3rd party vendor. Appropriate spill kits shall be kept in the Resin Lab. When absorbent material is used, it shall be promptly removed and properly disposed of.

LABELS

All materials storage containers shall be properly labeled. All containers shall be stored so that the labels are visible. Any hazardous waste that is generated shall be immediately and properly labeled. Empty containers should be so designated.

BMPs-Materials Management Resin Lab

- **CLEAN SPILLS IMMEDIATELY:** Clean spill immediately and completely. If absorbent materials are used, they should be removed and disposed of promptly. Spill kit should be located in the Resin Lab.
- **MATERIALS STORAGE AREA:** Designate areas for storage of specific materials
- **SECONDARY CONTAINMENT:** All materials shall be stored with secondary containment.
- **LABELLING:** All materials shall be adequately labeled and easily identifiable.

3.10 TEST KITCHEN

The Test Kitchen shall be a general kitchen facility for the development of educational, inspirational and entertaining food content to be shared on Instructables.com. Food editors will develop recipes and photograph their product for publication on Instructables.com. Kitchen use shall comply at all times with the Food Service Waste Reduction Ordinance, as set forth in San Francisco's Environment Code, Chapter 16.

DESIGNATED AREA

The Test Kitchen will be the designated area for food recipe development activities. Test Kitchen equipment includes refrigerator, oven, exhaust hood, dishwasher, microwave, dehydrator, freezer, FushionChef Sous Vide (low temperature cooking equipment), ice cream machine, Vitamix blender, KitchenAid mixer, food processor, and deep fryer (2 gallon capacity).

Recyclable materials, compostable materials, and landfill waste shall be separated and stored in designated areas. Each area shall have clear signage. Grease from the deep fat fryer will be stored separately 3 gallon containers and recycled by SF Grease cycle Program.

CONTROLS

The activities associated with the kitchen will all be performed within the Test Kitchen, with the following controls in place:

- Exhaust hood for odor control and fire suppression
- Waste water to sanitary sewer filtered by grease separator and trap
- ABC Fire extinguisher (5 lb.) located within Test Kitchen next to entrance

PROHIBITED ACTIVITIES

- Test Kitchen will not be used for sale of any food or beverage to the public and/or to Autodesk employees.
- Cooking odors shall not be allowed to emanate from the Premises.
- Use of any Polystyrene Foam food service ware is strictly prohibited.
- Foods prepared in Test Kitchen shall be for taste testing only, and not for general consumption.

GENERAL HOUSEKEEPING

Good housekeeping by all personnel is one of the most effective strategies to prevent pollution and/or fires. Key features of good housekeeping include:

- Clean spills immediately and completely
- Putting away all food and equipment when not in use
- Using clear signs and labels for all containers and ingredients
- Clean all areas after every use on a daily basis
- Clean hood and oven on a regular basis

- Inspect and service fire extinguisher on a regular basis

The following Best Management Practices (BMPs) shall be used for the Test Kitchen.

- **DESIGNATED AREA:** All Test Kitchen activities shall be conducted only in the Test Kitchen.
- **CONTROLS:** Use controls in Test Kitchen to isolate Test Kitchen odors, grease, and potential fires.
- **ADHERE TO PROHIBITIONS:** No sale of food or beverage, no use of Polystyrene Foam containers, and food preparation limited to taste testing, only.
- **GENERAL HOUSEKEEPING:** Maintain daily cleaning after every use. Cleaning only to be performed by authorized users with equipment and supplies dedicated to the Test Kitchen.

3.11 APPLIED INNOVATION LAB

The Autodesk Applied Innovation Lab at Pier 9 will be a work space to develop tools and techniques to design and understand robotic systems in further developing the interface of Autodesk software and hardware based systems. In addition to the workshop space there will be office space for the staff associated with the operation, maintenance and study of the workshop equipment. The following equipment is located in the Applied Innovation Lab; ABB-IRB-6700-205/2.80, Fanuc M-710iC/50 x 2, Universal Robots UR10.

The following Best Management Practices (BMPs) shall be used for the Applied Innovation Lab.

DESIGNATE AREA

All industrial robotic activity shall only take place in the applied innovation lab. Mechanical barriers shall be used to prevent manual or physical access into robotic danger zones during robotic activity.

CONTROLS

The activities associated with the Applied Innovation Lab will be performed in a secured, indoor workroom. The following additional controls will be put in place;

- Robot has a feature to prevent motion in the event of power failure
- Robot will not auto restart when power restarts
- Light curtains and interlock functions stop robot, if inadvertent action occurs

- Welding shall not be permitted during collaborative mode
- The installation of an enabling switch to deactivate the robot when in operation in the event of an inadvertent action.
- Robot has limiting devices that are preset to manage range
- Gas cylinders are to be secured at all times
- Exhaust control to limit welding fumes during robotic welding

ADHERE TO PROHIBITIONS

Robots are operated only by personnel who have completed appropriate training. All robots in Applied Innovation Lab conform with the following: ANSI/RIA R15.06-2012, CE Mari (incl EMC Directive, 2004/108/EC and Machinery Directive, 2006/42/EC), ISO 10218-1 (2011) for Robots and Robotic Devices- Safety Requirements, and PLd of ISO 13849-1.

GENERAL HOUSEKEEPING

General housekeeping will be maintained by the following;

- Clean all areas after use on a daily basis
- Put away all materials and tools when not in use
- Clean spills immediately and completely
- Trash to be emptied on a regular basis

SECURITY

Access to the Applied Innovation Lab entrance from the workshop space is restricted to only Applied Innovation lab users and other people required to access the lab. The main reason for this is to restrict access during the welding process. A sign shall be erected on the entrance to the Applied Innovation lab when the robotic welding process is taking place.

BMPs Materials Management- Applied Innovations Lab

EQUIPMENT USE: Only trained personnel may program and operate robots.

ROBOT SAFETY: All safety barriers and safety devices shall be put in place during robot operation.

FUME EXTRACTION: Employ fume extraction during robotic welding operation.

COMPRESSED GAS: Canisters are secured to wall at all times.

KEEP CLEAN: Keep area clean and orderly.

3.12 MARITIME ACTIVITY

The Office of the Chief Technology Officer (OCTO) at Autodesk will perform maritime research activities primarily in the San Francisco Bay. These activities include execution of non-invasive sensor surveys of man-made underwater objects. Autodesk will utilize two different types of remotely operated devices to perform these surveys as well as a manned tender vehicle. Limited dive operations will be conducted in support of this research. Autodesk is in the process of requesting a License to build a floating dock on the South side Apron of Pier 9. This dock will include a gangway and berthing space for two vehicles. The following vehicles will be used for the planned maritime research activities:

1. **Wave Adaptive Modular Vessel (WAM-V):** Battery powered remotely operated watercraft with an approximate size of 16' x 8'.
2. **Remotely operated underwater Vehicle (ROV):** ROV with an approximate size of 4'x 4'. ROV is electrically powered by a tether management system.
3. **Tender: Rigid Hull Inflatable Boat (RHIB):** with an approximate size of 24' x 9' used in the support of research activities, as well as personnel transport.
4. **Airstream Trailer:** Separate "command center" that supports maritime activities. This trailer must be towed by separate vehicle.

The following Best Management Practices (BMPs) shall be used at all times;

- **BE AWARE:** Be aware of the potential to pollute the Bay
- **TRAIN STAFF:** Train staff to be partners in protecting the Bay
- **DEBRIS MANAGEMENT:** Place trash and debris in the proper containers
- **END OF DAY CLEAN-UP:** At the end of the day or when activities are over, conduct a general clean-up to remove debris, trash and inspect for spills.
- **SWEEP:** Use dry cleaning methods rather than pressure washing surfaces.
- **CLEAN SPILLS IMMEDIATELY:** Keep equipment clean. Avoid excessive build-up of oil and grease.
- **EDUCATION:** Provide educational resources to all vessel operators berthing at Port facilities.

- **SPILL RESPONSE:** Maintain oil spill response including; emergency notification contacts and chemical spill kit.

OPERATIONS

This section describes the Tenant's operations and activities. These operations and activities shall be conducted in accordance with this Operations Plan.

1. **WAM-V:** Battery powered remotely operated watercraft with an approximate size of 16' x 8'. The WAM-V will be used with various sensor packages and will survey underwater man-made objects using non-invasive sensors. The WAM-V can be operated at distances of up to approximately ¼ mile from the remote operator, depending on conditions. WAM-V will be placed in the water at Pier 9. It will be stored at Pier 19 when not in use.
2. **ROV:** Remotely operated underwater vehicle with an approximate size of 4' x 4'. ROV is electrically powered by a tether. ROV will be operated underwater within sport-diving depth limits of no more than 130'. The ROV will be used with different sensor packages and will survey underwater man-made objects using non-invasive sensors. ROV can be lifted by hand and placed in the water and needs no hoist. ROV will be placed in the water at Pier 9 or from Tender. It will be stored at Pier 19 when not in use.
3. **Tender:** Inflatable boat with an approximate size of 24' x 9' used in the support of research activities, as well as personnel transport. Tender will be placed in the water at Pier 9.
4. **Airstream Trailer:** Separate "command center" that supports maritime activities. This trailer must be towed by separate vehicle. Airstream will be stored at Pier 9 when in use and at Pier 19 when not in use.

Autodesk is in the process of requesting a License to build a floating dock on the South side Apron of Pier 9. This dock will include a gangway and berthing space for two vehicles. If the Tenant would like to conduct new activities and operations; it shall submit a revised Operations Plan to the Port for approval. A revised Operations Plan shall specify at a minimum:

- Proposed new activities
- Additional locations for activities approved elsewhere
- New permit requirements (new permits and modifications to existing permits)
- BMP's that will be employed
- Other information reasonably required by Port.

The Port will respond promptly to any revised Operations Plan and, in case of disapproval, shall specify in detail the changes to the revised Operations Plan needed to gain Port's approval.

VEHICLE OPERATIONS

Vehicle Operations will include minor boat maintenance and storage activities located at Pier 9 and 19. This section describes the activities and BMPs required ensuring that the operations are clean and complying with the standards of the Clean Water Act and the Port of San Francisco.

Vessel maintenance activities are part of the BMPs and include boat rinsing, boat repair (minor) and boat and trailer storage. Vehicle maintenance activities will not be performed on Port property as part of these maritime activities.

The following activities are prohibited at all venues except in strict compliance with the provisions of the Lease, including the Environmental Requirements, and this Operations Plan.

- Handling any Hazardous Materials on or off any Vessels, and fueling of vessels.
- Handling on or off any vessels, any hazardous materials on behalf of third parties

FUELING

In water fueling of boats shall only occur at existing licensed public fuel docks. No fueling will be done at Pier 9 or 19.

TOOLS / EQUIPMENT: STORAGE AND USE

Only incidental/ minor repairs will be done at Pier 9 and 19. No fluids or Hazardous materials will be used.

BOAT REPAIR/MAINTENANCE

Only incidental/minor repairs will be done at Pier 9 and 19. No maintenance activities will be performed. Boat cleaning will be minimized at temporary floating docks. Boat cleaning shall be conducted only with freshwater (no additives or products). Sanding, refinishing and painting are prohibited.

FLOATING DOCKS AND BERTHED VESSELS

Autodesk is in the process of requesting to build a floating dock on the South side apron of Pier 9. This dock will include a gangway and berthing space for two vehicles. In addition Autodesk plans to install a safety ladder off the pier apron. All vessels using Port property or temporary floating docks shall comply with all laws and regulations. These include, but are not limited to those found in ***Appendix C-Select Maritime Rules and Regulations***.

PROHIBITION OF DISCHARGES

Discharges or releases of any kind are prohibited in the San Francisco Bay, unless specifically authorized under a state or federal permit. Autodesk will not discharge or release anything into the bay. In the event of a spill, Autodesk must report spills to both the U.S Coast Guard National Response Center (800) 424-8802 and Office of Emergency Services in your jurisdiction immediately. See information below;

EMERGENCY OIL SPILL NOTIFICATION

AGENCY	PHONE
National Response Center	(800) 424-8802
California Emergency Management Agency	(800) 852-7550
U.S. Coast Guard, Marine Safety Office	(510) 437-3073
Port of San Francisco	(415) 274-0400
Veolia Emergency Spill Response Services	(800) 688-4005

DIVE OPERATIONS

Autodesk will utilize divers on a limited basis to tend to the ROV. Divers may also perform limited survey functions such as manual capture of survey scans by use of non-invasive sensors. Divers will never exceed sport diving depth limits of 130' and will be certified by the appropriate agencies as necessary. Divers will enter the water either off the Pier 9 floating dock or off the Tender.

Several local, state and federal agencies might have jurisdiction over the Tenant's activities. Tenant is responsible for determining the full range of Laws applicable to its operations and compliance.

4.0 REGULATORY/ PERMITS

Several local, state and federal agencies might have jurisdiction over the Autodesk operations at Pier 9. This section provides a summary of some of these agencies and their regulatory requirements. A summary table of these select requirements can be found in Appendix E. Tenant is responsible for determining the full range of Laws applicable to its operations and compliance with such Laws.

4.1 CITY AND COUNTY OF SAN FRANCISCO

Several City and County of San Francisco agencies may exercise jurisdiction over the activities of tenants on Port property. These may include:

- Department of Public Health- Hazards Materials Unified Public Agency
- Department of Public Health-Food Service Establishments
- Public Utilities Commission- Fats, Oils and Grease (FOG) Control
- Public Utilities Commission-Industrial Waste Water (sewer discharges)
- Fire Department-Flammable Materials Hot Works, etc.
- Bay Area Air Quality Management District (BAAQMD)

Tenant shall be responsible for complying with the requirements of these and other local agency requirements, as applicable to Autodesk's operations at locations listed in 2.2 and will obtain any permits necessary.

SAN FRANCISCO FIRE DEPARTMENT

Tenant will obtain all necessary permits from the San Francisco Fire Department. The SF Fire Department issues several types of permits that might pertain to the Tenant's activities. Commonly issued permits pertain to the storage and use of flammable materials, hazardous chemicals and compressed gases, burning removal of paint, spray painting hot works and welding, battery systems and places of assembly for occupancy. A complete list of SF Fire Department permits is provided in Appendix N.

HAZARDOUS MATERIALS UNIFIED PROGRAM AGENCY- (HMUPA)

The tenant will obtain a permit from the San Francisco Department of Public Health Hazardous Materials Unified Program Agency (HMUPA). The HMUPA permit included six program elements that involve the storage and use of Hazardous Materials, including the generation of hazardous waste.

4.1 STATE OF CALIFORNIA

CALIFORNIA OCCUPATIONAL SAFETY AND HEALTH (CAL-OSHA)

California Division of Occupational Safety and Health (CAL-OSHA) is the regulator agency for pressure vessel permitting as well as employee health and safety standards.

DEPARTMENT OF TOXIC SUBSTANCES CONTROL (DTSC)

Department of Toxic Substances Control is the regulatory agency for hazardous wastes recycling and disposal.

DEPARTMENT OF RESOURCES, RECYCLING AND RECOVERY (DRRR)

DRRR oversees the states waste management and recycling programs.

4.2 FEDERAL

DEPARTMENT OF TRANSPORTATION (DOT)

Federal Department of Transportation (DOT) is the federal authority regulating the transportation of Hazardous Materials.

5.0 APPENDIX

5.1 SUMMARY OF BEST MANUFACTURING PRACTICES

General Use of Port Facilities

- **BE AWARE:** Be aware of the potential to pollute the Bay.
- **TRAIN STAFF:** Train staff to be partners in protecting the Bay.
- **DEBRIS MANAGEMENT:** Place trash and debris in the proper containers.
- **END OF DAY CLEAN-UP:** At the end of the day or when activities are over, conduct a general clean-up to remove debris, trash, and inspect for spills.
- **SWEEP:** Use dry cleaning methods rather than pressure washing surfaces.
- **CLEAN SPILLS IMMEDIATELY:** Keep equipment clean. Avoid excessive build-up of oil and grease.

Storage and Use of Tools and Equipment

- **KEEP CLEAN:** Keep tools clean and free of excessive grease and grime.
- **TOOL CONTAINER:** Properly store when not in use. Do not leave tools lying around. Store under cover.
- **CATCH DRIPS:** Place absorbent pads or drip pans under equipment that contains fluids.
- **INSPECT EQUIPMENT:** Inspect equipment weekly for leaks and needed repairs.
- **CLEAN SPILLS IMMEDIATELY:** Clean spill immediately and completely. If absorbent materials are used, they should be removed and disposed promptly.
- **SPILL KIT:** Keep a properly sized spill kit in all areas with the potential for leaks.

Materials Management

- **MATERIALS STORAGE AREAS:** Designate areas for storage of specific materials;
- **SECONDARY CONTAINMENT:** Store all materials with secondary containment;
- **DISPENSER CONTAINMENT:** Use secondary containment with drip reservoirs for dispensers;
- **CATCH DRIPS:** Place absorbent pads or drip pans under equipment that contains fluids;
- **CLEAN SPILLS IMMEDIATELY:** Clean spill immediately and completely. If absorbent materials are used, they should be removed and disposed promptly;
- **SPILL KIT:** Keep a properly sized spill kit in all areas with the potential for leaks;
- **LABELS:** Properly label all materials;
- **WASTE AREAS:** Designate areas to manage recyclable, compostable and landfill waste.

Print Shop Operation

- **KEEP CLEAN:** Keep tools and equipment clean.
- **RESIN CARTRIDGES:** Properly store in flammables cabinet.
- **COMPRESSED GAS:** Canisters are secured to wall or equipment cart at all times.
- **FUME EXTRACTION:** Employ fume extraction with either high pressure extractor or low pressure blowers where equipment use requires ventilation
- **CATCH DRIPS:** Place absorbent pads or drip pans under equipment that contains fluids.
- **INSPECT EQUIPMENT:** Inspect equipment weekly for leaks and needed repairs.
- **CLEAN SPILLS IMMEDIATELY:** Clean spill immediately and completely. If absorbent materials are used, they must be removed and disposed promptly.
- **SPILL KIT:** Keep a properly sized spill kit in all areas with the potential for leaks.

CNC Shop Operations

- **KEEP CLEAN:** Keep tools and equipment clean.
- **FLAMMABLES CONTAINER:** Properly store flammables in flammables cabinet.
- **DUST COLLECTION:** Employ dust collection system were equipment use creates dust.
- **FUME EXTRACTION:** Employ fume extraction with either high pressure extractor or low pressure blowers where equipment use requires ventilation
- **SECONDARY CONTAINMENT:** Place absorbent pads or drip pans under equipment that contains fluids.
- **INSPECT EQUIPMENT:** Inspect equipment weekly for leaks and needed repairs.
- **CLEAN SPILLS IMMEDIATELY:** Clean spill immediately and completely. If absorbent materials are used, they must be removed and disposed promptly.
- **SPILL KIT:** Keep a properly sized spill kit in all areas with the potential for leaks. **KEEP CLEAN:** Keep tools and equipment clean.

General Shop Operations

- **KEEP CLEAN:** Keep tools clean and free of excessive grease and grime.
- **TOOL CONTAINER:** Properly store when not in use. Do not leave tools lying around. Store under cover.
- **FLAMMABLES CONTAINER:** Properly store flammables in flammables cabinet.
- **DUST COLLECTION:** Employ dust collection system were equipment use creates dust.
- **FUME EXTRACTION:** Employ fume extraction with either high pressure extractor or low pressure blowers where equipment use requires ventilation

- **COMPRESSED GAS:** Canisters are secured to wall or equipment cart at all times.
- **CATCH DRIPS:** Place absorbent pads or drip pans under equipment that contains fluids.
- **INSPECT EQUIPMENT:** Inspect equipment weekly for leaks and needed repairs.
- **CLEAN SPILLS IMMEDIATELY:** Clean spill immediately and completely. If absorbent materials are used, they must be removed and disposed promptly.
- **SPILL KIT:** Keep a properly sized spill kit in all areas with the potential for leaks.
- **WASTE AREAS:** Waste materials will be removed to secured waste collection area.

Life Sciences Workroom Operations

- **CONTAIN ALL MATERIALS:** Keep all materials in Life Sciences Workroom.
- **DESIGNATED AREA:** All Life Sciences Workroom activities shall be conducted only in the Life Sciences Workroom.
- **CONTROLS:** Use controls to contain materials within Life Science Workroom and control access to only authorized users.
- **ADHERE TO PROHIBITIONS:** No discarding or transferring of organisms outside of Life Science Workroom.
- **GENERAL HOUSEKEEPING:** Maintain daily cleaning after every use. Cleaning only to be performed by authorized users with equipment and supplies dedicated to the Life Sciences Workroom.
- **BIOHAZARDOUS WASTE:** Properly store biohazardous waste in designated biohazardous waste containers. Biohazardous waste will be disposed on by a licensed 3rd party contractor.
- **SPILL KIT:** Keep a properly sized spill kit in all areas with the potential for leaks.

Test Kitchen Operations

- **DESIGNATED AREA:** All Test Kitchen activities shall be conducted only in the Test Kitchen.
- **CONTROLS:** Use controls in Test Kitchen to isolate Test Kitchen odors, grease, and potential fires.
- **ADHERE TO PROHIBITIONS:** No sale of food or beverage, no use of Polystyrene Foam containers, and food preparation limited to taste testing only.
- **GENERAL HOUSEKEEPING:** Maintain daily cleaning after every use. Cleaning only to be performed by authorized users with equipment and supplies dedicated to the Test Kitchen.

Resin Lab Operations

- **CLEAN SPILLS IMMEDIATELY:** Clean spill immediately and completely. If absorbent materials are used, they should be removed and disposed of promptly. Spill kit should be located in the Resin Lab.
- **MATERIALS STORAGE AREA:** Designate areas for storage of specific materials
- **SECONDARY CONTAINMENT:** All materials shall be stored with secondary containment.
- **LABELLING:** All materials shall be adequately labeled and easily identifiable.

Applied Research Lab Operations

- **EQUIPMENT USE:** Only trained personnel may program and operate robots.
- **ROBOT SAFETY:** All safety barriers and safety devices shall be put in place during robot operation.
- **FUME EXTRACTION:** Employ fume extraction during robotic welding operation.
- **COMPRESSED GAS:** Canisters are secured to wall at all times.
- **KEEP CLEAN:** Keep area clean and orderly.

Maritime Activity Operations

- **TRAIN STAFF:** Train staff to be partners in protecting the Bay.
- **BE AWARE:** Be aware of the potential to pollute the Bay.
- **EDUCATION:** Provide educational resources to all vessel operators berthing at Port Facilities.
- **END OF DAY CLEAN UP:** At the end of the day or when activities are over, conduct a general clean up to remove debris, trash and inspect for spills.
- **SWEEP:** Use dry cleaning methods rather than pressure washing surfaces.
- **CLEAN SPILLS IMMEDIATELY:** Keep equipment clean. Avoid excessive build-up of oil and grease.

Secured Waste Area

- **MATERIALS STORAGE AREAS:** Designate areas for storage of specific materials;
- **SECONDARY CONTAINMENT:** Store all materials with secondary containment;

- **DISPENSER CONTAINMENT:** Use secondary containment with drip reservoirs for dispensers;
- **COMPRESSED GAS:** Canisters are secured to wall or fencing at all times;
- **CATCH DRIPS:** Place absorbent pads or drip pans under equipment that contains fluids;
- **CLEAN SPILLS IMMEDIATELY:** Clean spill immediately and completely. If absorbent materials are used, they should be removed and disposed promptly;
- **SPILL KIT:** Keep a properly sized spill kit in all areas with the potential for leaks;
- **LABELS:** Properly label all materials;

5.2 APPENDIX B- SPILL RESPONSE

In the event of a significant spill or release the following steps will be taken immediately.

- **SAFETY FIRST** – Ensure the safety of personnel
- **STOP SPILL** – Stop spill at the source if safe to do so
- **CALL VEOLIA** - Initiate emergency spill response
- **CONTAIN** – Initiate containment activities
- **REPORT** – Report the spill to emergency and regulatory agencies.
- **CLEAN UP** – Initiate cleanup activities.

NOTIFICATION: in case of a spill, the Emergency Coordinator will call:

Will Call:	Veolia Technical Solutions (business hrs)	800-325-2382
	Veolia Technical Solutions (after hrs)	800-688-4005
Will Call:	SF Department of Public Health	415-252-3900
	California Office of Emergency Services	800-852-7550
	National Response Center	800-424-8802
Will Call:	SF Department of Public Works	415-695-2020
	(When Hazardous Materials/waste spills/leaks into a sewer)	
	Port of San Francisco	415-274-0400
	(Ask for environmental staff)	

Information to be reported includes:

1. **LOCATION** – Location of spill and company name.
2. **TIME** – Time of spill, or time first observed.
3. **SOURCE** – Note the source of spill, if known.
4. **MATERIAL** – Note type of material spilled.
5. **AMOUNT** – Estimate of amount spilled.
6. **WEATHER** – Describe the on-scene weather.
7. **HAZARDS** – Describe any known fire or health hazards posed by the spill.
8. **DESTINATION** – Where is the spill going and affected waters? Sensitive receptors?

- 9. **ACTION** – Acton being taken to contain and clean up the spill.
- 10. **ADDITIONAL** – Any information requested by the agency, so long as the information is known to be factual. Do not guess regarding the cause of potential impacts of spill.

5.3 APPENDIX C- SELECT MARITIME RULES AND REGULATIONS

These Maritime Rules and Regulations are adapted from the Port Tariff. For the full Tariff, go to the following internet link:

<http://www.sfport.com/modules/showdocument.aspx?documentid=2987>

FIRE, WELDING, AND OPEN FLAMES, RULES GOVERNING

Fire will not be used on board any vessel to heat flammable substances, while such vessel is in any slip, basin, channel, or canal, or moored to any wharf without the approval of the Fire Marshal, Chief Wharfinger, or Wharfinger.

(b) No bonfire nor open fire for the burning of rubbish or refuse materials, or for any other purpose, except as provided in this Item, will be allowed on any of the city property under the jurisdiction of the Commission.

(c) No welding or open fire will be allowed on any wharf, or upon any vessel in any ship, channel, basin or canal without the approval of the Fire Marshal, Chief Wharfinger, or Wharfinger. No such work shall be commenced until an operational permit therefore is approved. When "hot work" is to be conducted, operations shall conform to the current requirements of Chapter 26 of the SF Municipal Fire Codes.

FIRE EXTINGUISHERS REQUIRED

All tenants of the Port of San Francisco are required to furnish, maintain and service portable fire extinguishers in their leased or licensed areas in accordance with the S.F. Municipal Fire Code and U.S. Coast Guard regulations.

5.4 APPENDIX D-RULES AND REGULATIONS FOR OFFICE BUILDINGS

These Rules and Regulations shall apply to Tenant's use of all office buildings on Port property.

OBSTRUCTIONS

Sidewalks, entrances, passages, courts, elevators, vestibules, stairways, corridors or halls shall not be obstructed or encumbered by Tenant or used for any purpose other than ingress and egress to and from the Premises and if the Premises are situated on the ground floor of the Building, Tenant shall further, at Tenant's own expense, keep the sidewalks and curb directly in front of the Premises clean and free from rubbish.

APPEARANCES

Tenant shall not place anything against or near glass partitions, doors or windows which may appear unsightly from outside the Premises or the Property. No awning, showcase, articles or other unauthorized items shall be attached to the outside walls or windows of the Building without the prior written consent of Port. No curtains, blinds, shades, drapes or screens shall be attached to or hung in, or used in connection with any window or door of the Premises, without the prior written consent of Port. Such awnings, unauthorized items, curtains, blinds, shades, drapes, screens and other fixtures must be of a quality, type, design, color, material and general appearance approved by Port, and shall be attached in the manner approved by Port. All lighting fixtures hung in offices or spaces along the perimeter of the Premises must be of a quality, type, design, bulb color, size and general appearance approved by Port.

SIGNS

No sign, advertisement, notice, lettering, decoration or other thing shall be exhibited, inscribed, painted or affixed by Tenant on any part of the outside or inside of the Premises or of the Building, without the prior written consent of Port. In the event of the violation of the foregoing by Tenant, Port may remove it without any liability, and may charge the expense incurred by such removal to Tenant.

LIGHT

The sashes, sash doors, skylights, windows and doors that reflect or admit light or air into the halls, passageways or other public places in the Building shall not be covered or obstructed by Tenant, nor shall any bottles, parcels or other articles be placed on the window sills or in the public portions of the Building.

FIXTURES

The water and wash closets and other plumbing fixtures shall not be used for any purposes other than those for which they were constructed, and no foreign substances shall be thrown therein. Tenant shall shut off all water faucets or other water apparatus at the end of each day. Tenant shall be responsible for any damage or injuries sustained by other tenants or occupants of the Property or by Port for noncompliance with this rule.

ATTACHMENTS

Tenant shall not mark, paint, drill into or in any way deface any part of the Premises or the Building. No boring, cutting or stringing of wires shall be permitted, except with the prior written consent of Port, and as Port may direct. If Tenant requires wiring, conduit or connections for telecommunications, computer, burglar alarm or similar services, it shall first obtain, and comply with, Port's instruction in their installation. Tenant shall not go onto the roof or install any antenna or other devices on the roof or exterior walls of the Property without Port's written permission. Tenant shall not interfere with media broadcast reception to or from the Property or elsewhere. Tenant shall repair or be responsible for the cost to repair any damage resulting from noncompliance with this rule.

USE

Tenant shall not use the Premises for any business or activity other than that specified in the Lease. The Premises shall not be used for any activity disallowed by law or the Waterfront Land Use Plan.

SECURITY

Tenant must, upon the termination of the tenancy, restore to Port all keys to stores, offices and toilet rooms, either furnished to, or otherwise procured by Tenant, and in the event of the loss of any keys so furnished, Tenant shall pay to Port the cost thereof.

SALES

Canvassing, soliciting, peddling and distribution of handbills in the Building is prohibited and Tenant shall cooperate to prevent the same.

RIGHT OF ENTRY

Port reserves the right to exclude or expel from the Leased Area or Common Area any person who, in the judgment of Port, is intoxicated, under the influence of alcohol or drugs, or who shall in any manner do any act in violation of law or the rules and regulations of the Leased area. Port reserves the right to prevent access to the Property in case of invasion, mob, riot, public excitement or other commotion by closing the doors or by other appropriate action.

NOISE AND ODORS

Tenant shall not make, or permit to be made, any unseemly or disturbing noises or odors or disturb or interfere with occupants of the Building, or neighboring buildings or premises, or those doing business with them.

ANIMALS

No live animal, fish or bird of any kind shall be brought into or kept in or about the Premises or the Building, except seeing-eye dogs or other trained assistance animals.

FOOD

Tenant shall not prepare any food nor do any cooking, operate or conduct any restaurant, luncheonette or cafeteria for the sale or service of food or beverages to its employees or to

others without acquiring all required permits to do so, Food and beverage preparation by Tenant's employees using microwave ovens or coffee makers shall be permitted provided no odors of cooking or other processes emanate from the Premises. Tenant shall not install or permit the installation or use of any vending machine or permit the delivery of any food or beverage to the Premises except by such persons and in such manner as are approved in advance in writing by Port.

PEST CONTROL

If the Premises becomes infested with vermin as a result of the use, misuse or neglect of the Premises by Tenant, its agents, servants, employees, contractors, visitors or licensees, Tenant shall forthwith, at Tenant's expense, cause the same to be exterminated to the satisfaction of Port and shall employ such licensed exterminators as shall be approved in writing in advance by Port.

CLEANLINESS

Tenant shall store all its trash and garbage within its Premises and shall place all toxic waste within appropriate containers designated by health laws and regulations. Tenant shall not throw anything out of the doors, windows or skylights or down the passageways, or leave furnishings, supplies, equipment or debris in the common areas. Tenant shall not place in any trash box or receptacle any materials that cannot be disposed of in the ordinary and customary manner of trash and garbage disposal. All garbage and refuse disposal shall be made in accordance with directions issued from time to time by Port.

HAZARDOUS MATERIALS

Neither Tenant nor any of Tenant's agents, servants, employees, contractors, visitors or licensees shall at any time bring or keep upon the Premises any flammable, combustible or explosive fluid, chemical or substance. Tenant shall not bring any Hazardous Materials onto the Premises except for those, which are in general commercial use and are incidental to Tenant's business office operations and only in quantities suitable for immediate use.

DELIVERIES

There shall not be used in any premises, or in the public halls, plaza areas, lobbies, or elsewhere in the Building, either by Tenant or by jobbers or others, in the delivery or receipt of merchandise, any hand trucks or dollies, except those equipped with rubber tires and side guards. All deliveries shall be made at such reasonable hours and under such reasonable regulations as may be fixed by Port.

EQUIPMENT

Tenant shall not place a load upon any floor of the Premises which exceeds the load per square foot, which such floor was designed to carry and which is allowed by law. Tenant shall not install any machine or equipment which causes noise, heat, cold or vibration to be transmitted to the structure of the building in which the Premises are located without Port's prior written consent, which consent may be conditioned on such terms as Port may require.

MOVING

No equipment, materials, furniture, packages, supplies, merchandise or other property which when loaded into an elevator reasonably eliminates the use thereof for any period of time may be received in the Property or carried in the elevators without prior written notice to Port, and all moving of the same into or out of the Property shall be done at such time and in such manner as Port shall designate.

SAFES

All removals or the carrying in or out of any safes, freight, furniture, construction material, bulky matter or heavy equipment of any description must take place during the hours which Port or its agent may determine from time to time. Port reserves the right to prescribe the weight and position of all safes, which must be placed upon two-inch thick plank strips to distribute the weight. The moving of safes, freight, furniture, fixtures, bulky matter or heavy equipment of any kind must be made upon previous notice to the Building Manager and in a manner and at times prescribed by him, and the persons employed by Tenant for such work are subject to Port's prior approval. Port reserves the right to inspect all safes, freight or other bulky articles to be brought into the Building and to exclude from the Building all safes, freight or other bulky articles which violate any of these Rules and Regulations or the Lease of which these Rules and Regulations are a part.

ENERGY

Tenant shall not waste gas, electricity, water, heating or air-conditioning and agrees to cooperate fully with Port to assure the most efficient operation of the Property's heating and air-conditioning and to comply with any governmental energy-saving rules, laws or regulations of which Tenant has actual notice. Tenant shall keep corridor doors closed and, prior to leaving the Premises for the day, Tenant shall draw or lower window coverings and turn off all lights and water fixtures. Tenant shall keep its window coverings closed during any period of the day when the sun is shining directly on the windows of the Premises.

FIRE SAFETY

Tenant shall install and maintain, at Tenant's sole cost and expense, an adequate, visibly marked, and at all times properly operational fire extinguisher next to any duplicating or photocopying machine or similar heat producing equipment, which may or may not contain combustible material, in the Premises.

SMOKING

Smoking is prohibited in the Premises and all enclosed Common Areas of the Building, including, without limitation, the main lobby, all hallways, all elevators, all elevator lobbies, all restrooms and the parking areas.

ADVERTISING

Port shall have the right to prohibit any advertising or business conducted by Tenant referring to the Building which, in Port's opinion, tends to impair the reputation of the Building or its

desirability as a first class building for offices and/or commercial services and upon notice from Port, Tenant shall refrain from or discontinue such advertising.

COIN MACHINES

Only Port shall have the right to place in and upon the Common area pay phones and coin-operated machines for the sale of beverage, candy and other merchandise or service.

PARKING

Tenant, Tenant's agents, servants, employees, contractors, licensees, or visitors shall not park any vehicles in any driveways, service entrances, or restricted parking areas and shall comply with any other parking regulations imposed by Port from time to time.

AMENDMENTS

Port reserves the right at any time to add, change or rescind any one or more of these rules and regulations or to make such other and further rules and regulations as the Port shall determine is in the best interest of the Common Area, the Tenants and their business agents and invitees. In the event of any conflict between these or any modified rules and regulations and the Lease, the terms and provisions of the Lease shall prevail.

5.5 APPENDIX E-SELECT PERMITTED & REGULATED ACTIVITY (SUMMARY TABLE)

CITY & COUNTY OF SAN FRANCISCO				
AGENCY	REGULATED ACTIVITY	REQUIREMENT	APPLIES	PERMIT NO.
Port of San Francisco	- Post-Construction Storm water	Storm water Control Plan	Unknown	
SF Department of Public Health – Hazardous Materials Unified Program Agency (HMUPA)	- Hazardous Materials Storage - Hazardous Waste	Hazardous Materials Business Plan Review/Approval of Proposal	YES YES	Business ID #: 32633
SF PUC	- Industrial Wastewater - Fats, Oils, Grease Control	Industrial Discharge Permit FOG Control Compliance	YES	13-04855
SF Fire Department	- Flammable Materials - Compressed Gases - Open Flame Devices - Hot Works, Welding, Cutting		YES	51979
BAY AREA				
AGENCY	ACTIVITY	REQUIREMENT	APPLIES	PERMIT NO.
Bay Area Air Quality District	-Coatings	Coatings permit VOC limits and tracking	YES	21861
STATE OF CALIFORNIA				
AGENCY	ACTIVITY	REQUIREMENT	APPLIES	PERMIT NO.
DTSC	-Hazardous Waste Generation	CAL-EPA ID Numbers (SQG)	YES	CAL00037 9411
Cal-OSHA	-Employee Health and Safety	Boiler permits Elevator permit Air compressor permit	NO YES YES	N/A 163738 A004650-13
FEDERAL				
AGENCY	ACTIVITY	REQUIREMENT	APPLIES	PERMIT NO.
DOT			Unknown	

5.6 APPENDIX F- AUTODESK SITE MAP



Pier 9 Site Plan

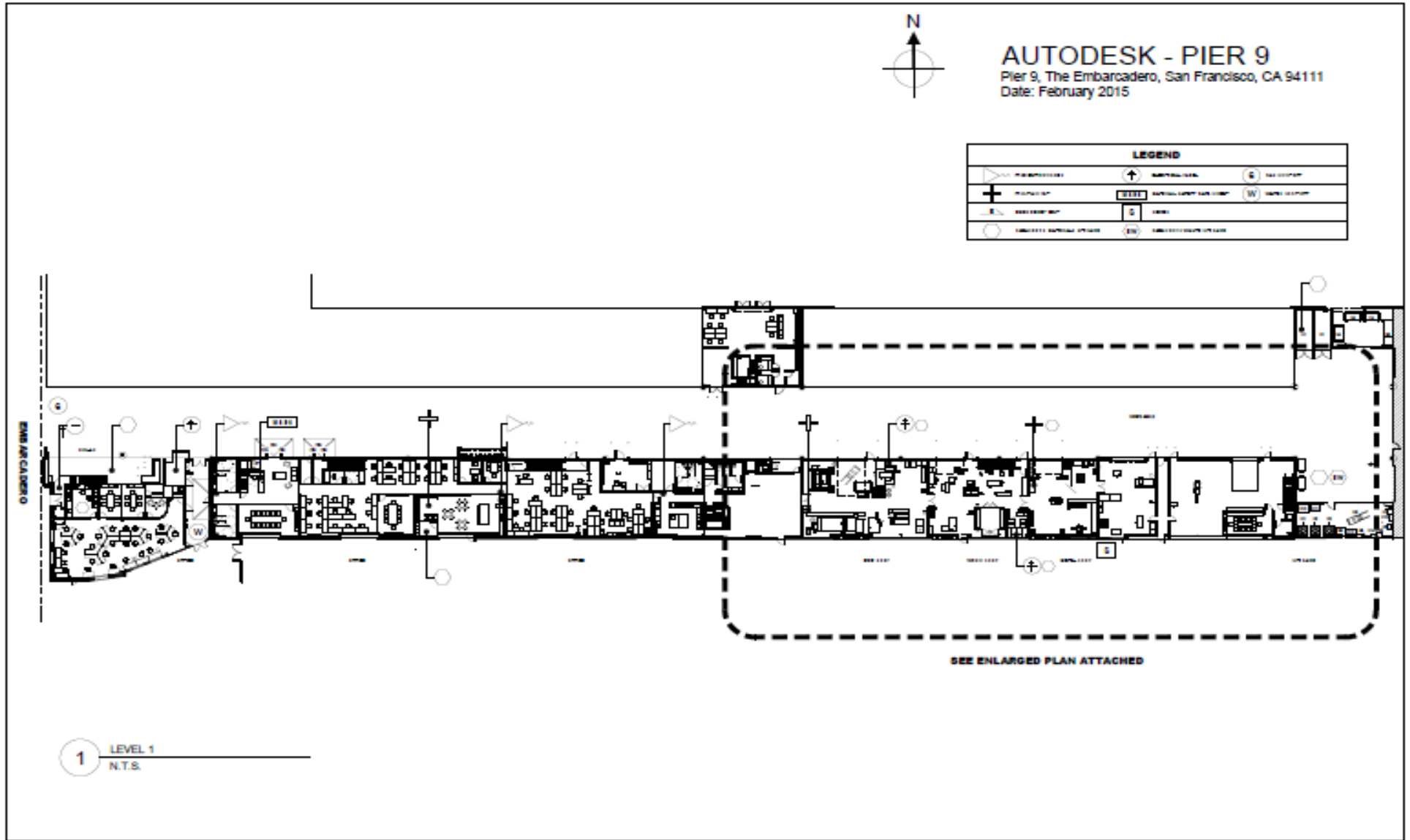

5.7 APPENDIX G-AUTODESK CHEMICAL INVENTORY

AUTODESK CHEMICAL INVENTORY 2015		
Chemical Name	Max Quantity	Location
General Workshop Chemicals		
3M Scotch-Weld Super 77 Cylinder Spray Adhesive	12 oz	Woodshop
PLATINUM - DIVINYLTETRAMETHYLDISILOXANE COMPLEX		Project Storage Container
275 Lead Free Flux Cored Solder	1.2 lbs	Electronics Lab
3 in 1 Oil	8 oz	Woodshop
3M super duty Rubbing Compound	1 Qt	Woodshop
3M auto- lens & hard plastic cleaner	8 fl oz	3D Print Shop
3M auto- lens polish&protector	8 fl oz	3D Print Shop
3M Fastbond Contact Adhesive 30-NF Green	1 gal	Metal Shop
3M Fluorinert Electronic Liquid FC-3284	1000 mL	Project Storage Container
3M marine Restorer Wax	16.50oz	Woodshop
3M Scotch-Weld 2216B/A, 3549 B/A (structural bond)	2 oz	Project Storage Container
3M Specialty Adhesive Remover	15 oz	Woodshop
3M Stainless Steel Cleaner & Polisher	21 oz	Janitor Closet
3M(TM) Fastbond(TM) Contact Adhesive 30-NF, Neutral	1 qt	Project Storage Container
Abatron Woodepox Part A	pint	Woodshop
Abatron Woodepox Part B	pint	Woodshop
Accu-lube 2000	1 gal	Metal Shop
Ace Rust Stop	8 oz	Woodshop
Ace Acetone	1 pt	Metal Shop
Ace Thread Cutting Oil	32 oz	Woodshop
ACE® GLO SPRAY Flourescent Go Go Green	12 oz	Woodshop
ACE® Premium Enamel, Black Flat	12 oz	Woodshop
ACE® Premium Enamel, Flat White	12oz	Woodshop

Acrylite LED		3D Print Shop
Acrylite LED (Evonik CYRO LLC)	25 lb	3D Print Shop
Acrylite Optical		3D Print Shop
AcrylPro Ceramic Tile Adhesive	1/2 gal	Woodshop
ADSK 4D	1 L	3D Print Shop
Aervoe Any-Way Spray Paint - Aerosol	12 oz	Woodshop
AFM Safecoat Naturals Clear Penetrating Oil	1 gal	Woodshop
Akzo Liquid Nails Adhesive	4 oz	Woodshop
Aleene Tacky Glue	8 oz	Woodshop
All Liquid Stainlifter	3.17 lb (50 oz)	MoldMaking Room
Aluminum & Stainless Steel Metals	Varied	Materials Storage Cage
Arcair Protex Original	16 oz	Metal Shop
Arctic Alumina Premium Thermal Compound	1.75 gram	Woodshop
Argon	<150 cu ft	Metal Shop
Argon/CO2 Mixture	<150 cu ft	Metal Shop
ASTROGLIDE®	4 oz	MoldMaking Room
Auto Air Colors Paint (all colors and reducer)		Woodshop
Barge all purpose TF cement (Toluene Free)	1 Qt	Woodshop
Barton Garnet Blasting Abrasive	55 lb	CNC Shop
Behold Furniture Polish	16 oz	Janitor Closet
Benjamin Moore Natura Paint- Eggshell	1 gal	Woodshop
Benjamin Moore Natura Paint- Flat	1 gal	Woodshop
Benjamin Moore Natura- Semi-Gloss	1 gal	Woodshop
Bioguard 3" Chlorinating Tablets	12 lbs	Project Storage Container
Bioshield Wood Counter (food safe) finish	8 oz	Woodshop
Birchwood Casey PSP Gun Blue	3 oz	Project Storage Container
Birchwood DRI TOUCH® Low-VOC Rust Preventive	1 gal	Woodshop
Birchwood Technologies Presto Black BST4 530050	1 gal	Corrosive Cabinet

Birchwood Technologies Satin Shield SS10 Sealant	1 gal	Metal Shop
Blaster PB Penetrating Catalyst	11 oz	Woodshop
Blick Artist Acrylic Hardener	8 oz	Woodshop
Blick Block Printing Ink: Black: 40305-2006	16 oz	Woodshop
Blick Block Printing Ink: Silver: 40305-9306	16 oz	Woodshop
blickrylic	1/2 gal	Woodshop
Blue Cat Hair Conditioner	1 gal	Janitor Closet
Blue Cat Hair Shampoo	1 gal	Janitor Closet
Body Double Part A	3 lbs	Project Storage Container
Bona Traffic	1 gal	Project Storage Container
Bondo Gold Filler		Woodshop
Bondo® Lightweight Body Filler		Flammable Cabinet
Bostik Glidecoat	10 oz	Woodshop
Bostik Never Seeze	4 oz	Woodshop
Bostik Top Cote	10 oz	Woodshop
Bright Copper Electroforming Solution, Product #335074	1 quart	Project Storage Container
BROMOTHYMOL BLUE INDICATORS, AQUEOUS	1 L	Studio 9
BSI Insta-Set Cyanoacrylate Accelerator	2 oz	Woodshop
BSI Insta-Cure Cyanoacrylate	4oz	Woodshop
Butcher Block Goodstuff		Woodshop
Castin Craft Casting Resin	16 oz	Project Storage Container
Castin Craft Mold Builder		Flammable Cabinet
CerMARK LMM-6000	12 oz	Woodshop
Chock Fast Gray Resin	1 gal	Metal Shop
Chockfast Grey Hardner	8 oz	Metal Shop
Christy's Red Hot Blue Glue (Low VOC formula)	1 pint	Woodshop
Cimtech 3200VLZ Coolant	55 gal	Hazardous Waste Cage
Cimtech 3200VLZ Coolant	55 gal	Hazardous Waste Cage

CIMtech 320-HFP with FACT	55 gal	Hazardous Waste Cage
Circuit Scribe – Conductive Ink Pen		Office
Clear Lacquer Sealant and Tarnish Inhibitor, Product #335149	1 pint	Project Storage Container
Clorox Scented Bleach	64 oz	Project Storage Container
Clorox® Regular Bleach1	63 oz	Project Storage Container
Combo Belt & Bench Grinder Oil		Project Storage Container
Comet Deodorizing Cleanser	32 oz	Project Storage Container
Comet Disinfecting Sanitizing Bathroom Cleaner	945 mL	Project Storage Container
Coolube® 2210	1 gal	Hazardous Waste Cage
Coolube® 2210EP		Flammable Cabinet
Copper powder (sigma aldrich)	1 L	Project Storage Container
D-Limonene	1 Gal	3D Print Shop
Dap All Purpose adhesive /Sealer	2.8 oz	Woodshop
DAP Plaster of Paris	8 lb	Moldmaking room
DAP Weldwood Non-Flammable Contact Cement	1 pint	Woodshop
DAP(R) AQUARIUM SILICONE SEALANT CLEAR, 688	2.8 oz	Woodshop
Daphne 2M Lubricant	1 gal	CNC Shop
Devcon Plastic Welder	0.84 oz	Woodshop
DEVCON® 5 Minute® Epoxy amber	84 oz	Woodshop
Dico Finecut 532-240 (metal buffer)	3 lb	Metal Shop
Diesel Exhaust Fluid AdBlue	10 L	Project Storage Container
DPD INDICATOR SOLUTION	1 L	Studio 9
Dragon Skin Series	2.8 lbs	MoldMaking Room
Dual™ Paint + Primer, Satin White	12 oz	Woodshop
DUPLI-COLOR® Car Art Temporary Paint, Black	5 Oz	Project Storage Container
DUPLI-COLOR® Car Art Temporary Paint, Blue	5 oz	Project Storage Container
DUPLI-COLOR® Car Art Temporary Paint, Red	5 Oz	Project Storage Container
DUPLI-COLOR® Car Art Temporary Paint, White	5 Oz	Project Storage Container

DUPLI-COLOR™ Engine Enamel with Ceramic, Chevrolet Orange	400 mL	Woodshop
Dupont Final Kleen V-3921S Spray Gun Cleaner	1 gal	Woodshop
E-Z Bond, Instant Glue, Cyanoacrylate	16 OZ	Woodshop
Eastwood "Low-VOC" PRE Painting Prep Formula, #11949Z	11 oz	Woodshop
Eco-Flo Gum Tragacanth (Tandy Leather 2620-01)	4 oz	Woodshop
Eco-Flo leather dye pack (Tandy Leather 2650-05)	2 oz	Woodshop
Eco-Flo Satin Shene (Taandy Leather 2611-01)	4 oz	Woodshop
Ecolab Jet Dry (Rinse additive for dishwasher)	1 gal	Janitor Closet
Ecolab Super Trump (Detergent for dishwasher)	1 gal	Project Storage Container
Electrocleaner Solution Mix, Product #335076	2 oz.	Project Storage Container
Elmers Glue all	16 oz	Woodshop
Elmers Carpenters Glue	1 gal	Woodshop
EM6000 Production Lacquer	1 gal	Woodshop
Encapso K	1 gal	Project Storage Container
Encore thermoplastic	< 25 lbs	3D Print Shop
Entropy Resins Super Sap® CCR Epoxy	3Qt	Woodshop
Entropy Super Sap® 100 Epoxy	2 Qt	Woodshop
Epilog Laser Lens Cleaner		3D Print Shop
Evazote® EV - all densities - white	N/A	3D Print Shop
Ferrotec EFH Series Ferrofluid	250 mL	Woodshop
Fiebing Neatsfoot Oil	8 oz	Woodshop
Folex Instant Carpet Spot Remover	32 oz	Janitor Closet
Form 1 Photoreactive Clear Resin	1 L	3D Print Shop
Form 1 Photoreactive Grey Resin	1 L	3D Print Shop
FUSOR 116 PLASTIC TO METAL CROSS BONDER	300mL	Woodshop
Gel Gloss Multi Surface	8 oz	Woodshop
Glomania Photoluminescent Pigment	2 oz	Project Storage Container
Glow Worm Green and Blue	6 oz	Woodshop

Goof Off Super Glue Remover	4 oz	Woodshop
Gorilla Glue	10 oz	Woodshop
Gorilla Glue	10 oz	Woodshop
Gorilla Super Glue	3 oz	Woodshop
Gorilla Wood Glue	3 oz	Woodshop
Granite Surface Plate Cleaner Accurate Manufactured Products Group	1 pint	Project Storage Container
HAAS Mobil SHC	16 oz	Woodshop
HASA MURIATIC ACID	1 Gal	Studio 9
Hi-Float balloon treatment		Woodshop
Hoover Floor Mate Hard Floor Cleaning Solution	32 oz	Janitor Closet
Howard Butcher Block Oil	12 oz	Woodshop
Industrial Supreme Low Conductivity Antifreeze/Coolant	1 gal	Project Storage Container
IPS Weld-On #16 (acrylic glue)	5 oz	Woodshop
IPS Weld-On #3 (acrylic glue)	4 oz	Woodshop
Iron Powder (sigma aldrich)	2 kg	Project Storage Container
Isopropyl Alcohol	1L	3D Print Shop
Jacquard idye 447 Yellow Poly	16 oz	Project Storage Container
Jacquard idye 449 Red Poly	16 oz	Project Storage Container
Jacquard idye 450 Violet Poly	16 oz	Project Storage Container
Jacquard idye 451 Blue Poly	16 oz	Project Storage Container
Jacquard idye 452 Green Poly	16 oz	Project Storage Container
Jacquard idye 454 Black Poly	16 oz	Project Storage Container
Jacquard idye 455 Golden Yellow Poly	16 oz	Project Storage Container
Jacquard idye 459 Turquoise Poly	16 oz	Project Storage Container
KastEZ Polyurethane Resin	2 quart	Woodshop
KEM 400 Enamel	1 gal	Metal Shop
Klean Strip Green Safer Paint Thinner		Woodshop
Klean Strip Klean Kutter		Woodshop

Klean-Strip Boiled Linseed Oil		Flammable Cabinet
Kool Mist Formula 78	1 gal	Metal Shop
Krylon Clear Polyurethane Coating (all colors)	11 oz	Woodshop
Krylon Clear Varnish Coating (all colors)	12 oz	Woodshop
Krylon Colormaster Brushed Metallic	11 oz	Woodshop
Krylon Colormaster Crystal Clear	12 oz	Woodshop
Krylon Colormaster Plastic Primer	12 oz	Woodshop
Krylon Colormaster Primer (all colors)	12 oz	Woodshop
Krylon Dual Paint & Primer (all colors)	12 oz	Woodshop
Krylon Dual Paint & Primer Metallic Finish (all colors)	12 oz	Woodshop
Krylon Dual Paint and Primer Hammered Finish	12 oz	Woodshop
Krylon Exterior Semi-Transparent Wood Stain (all colors)	12 oz	Woodshop
Krylon Fusion for Plastics (all colors)	12 oz	Woodshop
Krylon Glitter Blast (all colors)	6 oz	Woodshop
Krylon Glitter Blast Cherry Bomb	12 oz	Woodshop
Krylon Glitter Blast Clear Sealer	6 oz	Woodshop
Krylon Glitter Blast Lucky Green	12 oz	Woodshop
Krylon Glitter Blast Silver Flash Paint	12 oz	Woodshop
Krylon Interior/Exterior Paint, Simply Pink Satin	12 oz	Woodshop
Krylon Premium Original Chrome 1010	8 oz	Woodshop
Krylon Premium Sterling Silver 1030	8 oz	Woodshop
Krylon Rust Protector Clear Coating	12 oz	Woodshop
KRYLON® Chalkboard Spray, Black	12 oz	Woodshop
KRYLON® ColorMaster™ with Covermax™ Technology Acrylic Crystal Clear, Gloss	12 oz	Woodshop
KRYLON® ColorMaster™ with Covermax™ Technology, Gloss Sun Yellow	12 oz	Woodshop
KRYLON® ColorMaster™ with Covermax™ Technology, Gold	12 oz	Woodshop
KRYLON® Matte Finish Spray Coating	12 oz	Woodshop

Kylon Glitter Blast Golden Glow	12 oz	Woodshop
La Marzocco Espresso Machine Cleaner	20 oz	Break Room
Liquid Nails Adhesive	4 oz	Woodshop
LMM14 Black Laser Marking Paste	50 g	Project Storage Container
Loctite 222MS Threadlocker	50 ml	Woodshop
Loctite 290 Threadlocker	50 ml	Woodshop
Loctite Epoxy Plastic Bonder	.85 fl oz.	Woodshop
Loctite Polyseamseal Painters	10 oz	Woodshop
Loctite Threadlocker Blue 242	50 ml	Woodshop
Loctite Threadlocker Red 271 Heavy Duty	50 ml	Woodshop
LOCTITE® E-05MR™ Hysol® EPOXY ADHESIVE	50 mL	Woodshop
LPS 3 Heavy- Duty Rust Inhibitor	1 gal	Project Storage Container
Lubri-Matic Disc/ Drum	16 oz	Woodshop
Lumisil 866 A		Project Storage Container
Lumisil 866 B		Project Storage Container
Makerbot Impact Polysterene		Office
MC-Bond Acrylic Cement	1 qt	Woodshop
Mcor Technologies Adhesive		Woodshop
Midas Bright Copper Electroforming Solution	1 Qt	Electronics Lab
Minwax 61860 1 Quart White Wash Pickling Stain	1 Qt	Woodshop
Minwax Polyacrylic Water-Based Protective Finish	1/2 Pint	Woodshop
MINWAX POLYCRYLIC Gloss Protective Finish (aerosol), Clear	11.5 oz	Woodshop
Minwax Polyshades 275 VOC Compliant	1 qt	Woodshop
Minwax Sanding Sealer (professional formula)	1 qt	Woodshop
MiraLAX	45 Doses	MoldMaking Room
Mixol Universal Tints	20mL	MoldMaking Room
Mobil 1 10w 40w 4T Oil	1 Qt	Woodshop
Mobil Oil DTE 26 Hydraulic Oil, ISO Grade 68, SAE 20	1 gal	Project Storage Container

Mobil Vectra #2 Way Oil	1 gal	Woodshop
MOBILGEAR 600 XP 150	1 gal	Project Storage Container
Mohawk Instant Glue Gap Filling	2 oz	Woodshop
Mona Lisa Spray Adhesive	6 oz	Woodshop
Montana Black NC. Formula Spray Paint	400 mL	Woodshop
Montana Gold Spray Paint		Woodshop
NCF Quick Aerosol Accelerant	6 oz	Woodshop
NeverWet	18oz	Woodshop
Novus #1, #2, #3 Plastic Polish	8 oz	Woodshop
Oomoo Rubber	2.8 lbs	MoldMaking Room
Optishield Plus Corrosion Inhibitor	1 gal	Project Storage Container
PET (Polyethylene Terephthalate)- Clear Food Safe Plastic	Any	MoldMaking Room
pH 10.00 Buffer solution	125 ml	Studio 9
pH 4.00 Buffer solution	125 ml	Studio 9
pH 7.00 Buffer solution	125 ml	Studio 9
PHENOL RED INDICATORS, AQUEOUS	1 L	Studio 9
Plasti Dip Spray	11 oz	Woodshop
Plasti Paste	2 lbs	MoldMaking Room
Platinum Silicone Putty	1 Pint	Woodshop
Polyethylene glycol 3350	2.5 kg	MoldMaking Room
Polystyrene	Any	MoldMaking Room
PORONÒ Microcellular Polyurethane Material	25 lb	MoldMaking Room
Presto Black Gel	8oz	Project Area Corrosive Cabinet
Prima Plastilina Clay	2 lb	MoldMaking Room
ProtecPlumber Lard Oil All	1 gal	Metal Shop
R.J. Marshall Hydrated Alumina	5 lb.	Project Storage Container
Rain-X Original Glass Treatment	12 oz	Woodshop
Rancilio Egro Milk System Cleaner	1L	Break Room

Rani X Wash and Wax	1 Cont	Metal Shop
Red Gage Fluid	1 oz	Woodshop
Renaissance Wax	65 ml	Woodshop
ROBINAIR VACUUM PUMP OIL	1 Qt	Test Kitchen
Rustlick WS 5050 Oil	1 gal	Woodshop
Rustoleum American Accent Gloss Pine Green	12 oz	Woodshop
Rustoleum Gloss Protective Enamel Sunrise Red	12 oz	Woodshop
Rustoleum Painter's Touch Clear Spray	12 oz	Woodshop
Rustoleum Painter's Touch Multi-Purpose Gloss Spray (various colors)	12 oz	Woodshop
Rustoleum Painter's Touch Multi-Purpose Satin Spray (various colors)	12 oz	Woodshop
Rustoleum Varathane Crystal Clear	11.25 oz	Woodshop
Rustoluem Painter's Touch Clear Gloss	12oz	Woodshop
Safeway Mineral Oil USP	16 oz	Project Storage Container
Sanis Heavy Duty Handscrub (Cintas)	33.8 oz	CNC Shop
Scotchman 75751		Woodshop
Scotchman Coolant	1 gal	Metal Shop
SEM High Build Primer Surfacer (all colors)	20 oz	Woodshop
SEM Self Etching Primer (all colors)	20 oz	Woodshop
Sennelier Delacroix Fixative Latour (soft pastel) aerosol	12 oz	Woodshop
Seventh Generation Natural Dish Liquid	50 oz	Janitor Closet
Seventh Generation Natural Glass Cleaner	32 oz	Janitor Closet
Shell Tonna S2 MX 68	5 gal	Hazardous Waste Cage
Shell Tonna S3M68 Oil	1 gal	CNC Shop
Shellawax cream (wood polish)	300 mL	Woodshop
Silicon Dioxide, Amorphous	500 grams	Project Storage Container
Silver Conductive Paint, Product #335068	1 oz.	Project Storage Container
Simple Green All Purpose Cleaner	24 oz	Woodshop
Smooth on Ease Release 200 Aerosol	14 oz	Woodshop

Smooth on Tarbender Part A and B	1 gal	Project Storage Container
Smooth On Universal Mold Release Spray	14 oz	Woodshop
Smooth-Cast 300	1 lb	MoldMaking Room
Smooth-on Ecoflex Series (silicone elastomer)	1 pint	Project Storage Container
Smooth-On Mold-Star 15, 16, 30	1 gal	MoldMaking Room
Smooth-on PMC 746 Polyurethane elastomer	1 gal	MoldMaking Room
Smooth-on XTC-3D	24 oz	Project Storage Container
Soma-Foama 25	15 lb	MoldMaking Room
Spaz Stix Aerosol Paints	3.5 oz	Woodshop
Speedball: White: 3703	16 oz	Woodshop
Spray Nine Grez-Off Heavy Duty Degreaser	32 oz	CNC Shop
Stewart-MacDonald Slow Setting Epoxy Part A	2 oz	Woodshop
Stewart-MacDonald Slow Setting Epoxy Part B	2 oz	Woodshop
Stratasys Objet (Polyjet) 3D Print Resins	0.8 gallons	3D Print Shop
Stratasys Waterworks	8 gal	3D Print Shop
Styrospray 1000 Part A	1 qt	Woodshop
Styrospray 1000 Part B	1 qt	Woodshop
Tadco Formula 8038A	1 gal	MoldMaking Room
Tadco Formula 8038B	1 gal	MoldMaking Room
Tanners Bond Leathercraft Cement (Tandy Leather 2540-01)	4 oz	Woodshop
Tannic Acid	1 lb	Project Storage Container
TAP Acrylic Cement	16 oz	Woodshop
Tap Magic Aluminum Cutting Fluid	1 gal	Woodshop
Testors PlasticModel Finishing with Gloss Enamel (various colors)	1 Pk	Metal Shop
Thermark Cermark LMM-6000 Laser Marking Ink	12 oz	Woodshop
Tide HE Free and Gentle	50 oz	MoldMaking Room
Titebond Cold Press Veneer Glue	1 Qt	Woodshop
Titebond III Ultimate Wood Glue	1 gal	Woodshop

Titebond Original Wood Glue	1 gal	Woodshop
TRI-FLOW® Industrial Lubricant	18 oz	3D print shop
Trim Paint Matt Black	11.3 Oz	Woodshop
Tungsten Electrodes for Welding		Metal Shop
Undu VOC Compliant Adhesive Remover	4 oz	Woodshop
USG Hydrocal, SC-1094	10 lb.	Project Storage Container
Valvoline SAE 30 motor oil	1 qt	Project Storage Container
Varathane Water-Based Aerosol Clear Spray Product	11.25 oz	Woodshop
VHT® FlameProof Coating 1300-2000°F (704-1093°C), Flat Black	400 mL	Woodshop
Vinyl Printer Ink (Eco-Sol Max)	400 mL	3D print Shop
Visijet FTX Green		3D print Shop
Watco Low Voc Danish Oil 275	1 qt	Woodshop
Waxie Lan-O-Tone Liquid Lotion Soap	1 gal	Janitor Closet
Waxie Solsta 243 Green Neutral Cleaner	.792 gal	Janitor Closet
Waxie Solsta 543 Green Glass & Surace Cleaner	.792 gal	Janitor Closet
WD 40 Silicon Lube	11 oz	Woodshop
Weld Kleen 350 Anti-Spatter	1 gal	Metal Shop
WELD-ON 790 Low VOC Multi-Purpose Plastic Pipe Cement	1pint	Woodshop
Welding Rod 70S-2	NA	Metal Shop
Welding Rod Aluminum Alloy ER4043	NA	Metal Shop
Welding Rod Carbon Steel ER70S-6	NA	Metal Shop
Welding Rod Silicon Bronze SILBRZ-094	NA	Metal Shop
Welding Rod Stainless Steel ER308L	NA	Metal Shop
Welding Rod Stainless Steel ER309L	NA	Metal Shop
Welding Rod Stainless Steel ER312	NA	Metal Shop
Weldwood multipurpose spray adhesive	16 oz	Woodshop
Weldwood Nonflammable Contact Cement	1 Qt	Woodshop
West System Epoxy Hardener 207	1 qt	Woodshop

West System Epoxy Resin 105	1 gal	Woodshop
West System Exoxy Hardener 205	1 qt	Woodshop
Whiting (Marble Dust), FM-1039	5 lb.	Project Storage Container
Wood-Kote Clear and Clean or Clear and Clean II- Clear	1 pt	Woodshop
Wood-Kote colorant dye stains (any color)	1 pt	Woodshop
Wood-Kote Glaze Kote 250 (All colors)	1 pt	Woodshop
Wood-Kote Jel'd Poly Kote 250- Clear Matte	1 pt	Woodshop
Wood-Kote Jel'd Stain 250 (All colors)	1 pt	Woodshop
Wood-Kote Jel'd Stain H2O (All colors)	1 pt	Woodshop
Wood-Kote Ultra Flagship UV 250-Clear (Gloss, Satin, Matte)	1 pt	Woodshop
Wood-Kote WoodBuddy (filler)	12 oz	Woodshop
Wood-Kote WoodPerfect (filler)	12 oz	Woodshop
Z-Bond Cyanoacrylate		Woodshop
ZAR ULTRA MAX OMU – ALL GLOSS LEVELS	1 gal	Woodshop
ZAR ULTRA MAX OMU – ALL GLOSS LEVELS	1 gal	Woodshop
zb®61 binder (clear, cyan, magenta, yellow, black)		3D Print Shop
zb63 Binder	1L	3D Print Shop
zp®150, zp®151 Powder		3D Print Shop
AG-610 Silver conductive ink		Woodshop flammables cabinet
AA-Duct 904 Epoxy Resin	50g	Project storage container
Q-SIL 214 (two part silicone)	16oz	3D Print Shop
Q-SIL 233 (two part silicone)	16oz	3D Print Shop
LIFESCIENCE WORKROOM CHEMICAL INVENTORY		
2-mercaptoethanol	50 ml	4 degree fridge
Carbenicillin	5 g	4 degree fridge
chloramphenicol	25 g	4 degree fridge
collagen, rat tail	100 mg	4 degree fridge
collagenase, type II	1 g	4 degree fridge

E-gel sample buffer	1 ml	4 degree fridge
F-12 media	500 ml	4 degree fridge
HEPES buffer	20 ml	4 degree fridge
kanamycin sulfate	5 g	4 degree fridge
L1 algal growth media	250 ml	4 degree fridge
LB broth	1 L	4 degree fridge
potato dextrose agar	250 ml	4 degree fridge
RediLoad	1 ml	4 degree fridge
SDA NHS-diazirine	50mg	4 degree fridge
SOC outgrowth media	100 ml	4 degree fridge
spermine free base	5 g	4 degree fridge
sulfo-SDA diazirine	20 mg	4 degree fridge
trans-cinnamaldehyde	25 g (liq.)	4 degree fridge
YPD broth	1 L	4 degree fridge
Acetic acid, glacial	500 ml	acid cabinet
Ammonium Hydroxide 5N	500 ml	acid cabinet
Diphenyliodonium Nitrate	25 g	acid cabinet
hydrochloric acid 35%	100 ml	acid cabinet
hydrochloric acid 6N	1 L	acid cabinet
perfluorodecyl-triethoxysilane	5 g (liq.)	acid cabinet
pH standards pack 4-7-10	500 ml	acid cabinet
sodium hydroxide 10M	100 ml	acid cabinet
sodium hydroxide pellets	100 g	acid cabinet
Sulfuric Acid 5.25 N	100 mL	acid cabinet
2-hydroxy-4'(2-hydroxyethoxy)-2-methylpropiophenone	10 g	dessicator
ascorbic acid 2-phosphate sesquimagnesium	5 g	dessicator
chitosan powder	100 g	dessicator
Glyoxilic Acid monohydrate	25 g	dessicator

lithium phosphine oxide	25 g	dessicator
Martius yellow	25 g	dessicator
compressor oil	500 ml	flammable cabinet
DMSO	30 ml	flammable cabinet
DMSO	50 ml	flammable cabinet
DMSO	250 ml	flammable cabinet
ethanol, 99.7%	100 ml	flammable cabinet
ethanol, 99.7%	500 ml	flammable cabinet
ethanol, denatured 70%	4 L	flammable cabinet
Form 1 Castable Resin	500 ml	flammable cabinet
Form 1 clear resin	1 L	flammable cabinet
Form 1 flex resin	500 ml	flammable cabinet
Form 1 White Resin	1 L	flammable cabinet
IdeaPaint Primer	1 quart	flammable cabinet
IdeaPaint White	1 quart	flammable cabinet
isopropanol	1 L	flammable cabinet
methanol	100 ml	flammable cabinet
OS-10 hexamethyldisiloxane	4 L	flammable cabinet
OS-30 tetrasiloxane	4 L	flammable cabinet
polyethylene glycol diacrylate, 700 MW	500 ml	flammable cabinet
SDS pellets	100 g	flammable cabinet
sodium periodate	5 g	flammable cabinet
spray adhesive	1 L	flammable cabinet
Sylgard 184 base	500 ml	flammable cabinet
Sylgard 184 curing agent	100 ml	flammable cabinet
Tetraethyl Orthosilicate	1 L	flammable cabinet
0.25% trypsin EDTA	100 ml	freezer
ampicillin	25 ml	freezer

ampicillin	10 ml	freezer
Arg-Gly-Asp	10 mg	freezer
fetal bovine serum	500 ml	freezer
glycol chitosan	5 g	freezer
homoserine lactone	10 mg	freezer
kanamycin sulfate	100 ml	freezer
Melanin, Synthetic	100 mg	freezer
penicillin streptomycin	100 ml	freezer
Phusion Master Mix	100 rxn	freezer
polyethylene glycol diacrylate, 10000 MW	1 g	freezer
polyethylene glycol diacrylate, 6000 MW	1 g	freezer
Tetracycline Hydrochloride	5 g	freezer
Clear Photopolymer Resin	1 L	PS cabinet
drierite	2 kg	PS cabinet
agar powder	500 g	reagent shelf
agar powder	500 g	reagent shelf
Boiling Chips (Cawhatev)	500 g	reagent shelf
calcium carbonate	500 g	reagent shelf
calcium chloride	100g	reagent shelf
calcium chloride dihydrate	500g	reagent shelf
chitin	100 g	reagent shelf
D-glucose	100 g	reagent shelf
Dipotassium Tris(1,2-benzenediolato) Silicate	50 g	reagent shelf
E-gel 1kb ladder	1 ml	reagent shelf
gelatin from bovine skin	500 g	reagent shelf
glycerol	100 ml	reagent shelf
kanamycin sulfate	1g	reagent shelf
LB broth (Lennox)	1 L	reagent shelf

LB broth with agar (Miller)	250 g	reagent shelf
Lithium Acetate Dihydrate	250 g	reagent shelf
Magnesium Chloride	2 lbs	reagent shelf
magnesium chloride hexahydrate	500 g	reagent shelf
maltose monohydrate	500 g	reagent shelf
mineral oil, heavy	1 L	reagent shelf
mineral oil, light	1 L	reagent shelf
PBS 7.4 pH buffer 1X	500 ml	reagent shelf
peptone (vegetable)	500 g	reagent shelf
potassium chloride	250g	reagent shelf
potato dextrose agar	114 g	reagent shelf
rhamnose hydrate	5g	reagent shelf
Sea Salts	500 g	reagent shelf
sodium alginate	1kg	reagent shelf
sodium chloride	250g	reagent shelf
Sodium Thiosulfate Pentahydrate	25 g	reagent shelf
sucrose	250g	reagent shelf
TAE buffer 10X	1 L	reagent shelf
Trackit 1kb ladder	1 ml	reagent shelf
tryptone	250 g	reagent shelf
Ultrapure agarose	100 g	reagent shelf
Ultrapure LMP agarose	50 g	reagent shelf
yeast extract	500 g	reagent shelf
YPD broth	250 g	reagent shelf
Liqui-nox	947 ml	sink
Liquid Glass Bar Coating	4 gal	waste cabinet
RESIN LAB		
(tridecafluoro-1,1,2,2-tetrahydrooctyl)triethoxysilane	0.044pounds	Resin Lab

1,8-Diazabicyclo[5,4,0]undec-7-ene	0.11 pounds	Resin Lab
2-Acrylamindo-2-methyl-1-propanesulfonic acid	6.6gallons	Resin Lab
Acetaldehyde	0.054 gallons	Resin Lab
Acetone {2-Propanone}	0.5 gallons	Resin Lab
Acetonitrile	0.26 gallons	Resin Lab
Allyltrimethoxysilane	0.044 pounds	Resin Lab
Bis(2,2,6,6-tetramethyl-4-piperidyl) sebacate	0.22 pounds	Resin Lab
Bis(dimethylthiocarbamyl)disulfide	0.01 pounds	Resin Lab
Butyl Cellosolve	1 gallon	Resin Lab
BYK D-410	0.054 gallons	Resin Lab
BYK E-411	0.054 gallons	Resin Lab
Denatured Alcohol	0.5 gallons	Resin Lab
Dibutyltin Dilaurate	1.1 pounds	Resin Lab
D-Limonene	1 gallon	Resin Lab
Epo-Tek 301 Part B	0.3 gallon	Resin Lab
Ethyl acetate	0.26 gallons	Resin Lab
Ethylene Glycol	0.825 gallons	Resin Lab
Ferbam	0.055 pounds	Resin Lab
FLUROSILICONE	0.054 gallons	Resin Lab
FLUROSILICONE	0.054 gallons	Resin Lab
FormLabs Clear Photopolymer Resin	0.78 gallons	Resin Lab
Glycerol Dimethacrylate	3.9 gallons	Resin Lab
heptane	0.78 gallons	Resin Lab
Irgacure 1173	0.78 gallons	Resin Lab

Isopropyl alcohol (100%)	9 gallons	Resin Lab
Isopropyl alcohol (91%)	3 gallons	Resin Lab
Klean Strip paint thinner	1.5 gallons	Resin Lab
LUMISIL 886 A	0.54 gallons	Resin Lab
LUMISIL 886 B	0.54 gallons	Resin Lab
Methacrylamide	1.65 pounds	Resin Lab
Methacryloxypropyltrimethoxysilane	0.11 pounds	Resin Lab
METHOXYVINYL OLIGOMERIC SILOXANE	0.054 gallons	Resin Lab
METHYLHYDROSILOXANE DIMETHYSILOXANE COPOLYMER	0.054 gallons	Resin Lab
Nickel, bis(diethylcarbamo-dithioato-.kappa.S.,kappa.S')-, (SP-4-1)-	0.06 pounds	Resin Lab
Phenol	0.12 pounds	Resin Lab
PL-369 2-Benzyl-2-(dimethylamino)-4'-morpholinobutyrophenone	0.44 gallons	Resin Lab
Poly(oxy-1,2-ethanediyl), .alpha.,.alpha.'-[(1-methylethylidene)di-4,1-phenylene]bis[.omega.-[(1-oxo-2-propenyl)oxy]-	0.26 gallons	Resin Lab
Propylene glycol	1 gallon	Resin Lab
Sylgard 184 silicone elastomer base	0.079 gallons	Resin Lab
Sylgard 184 silicone elastomer curing agent	0.079 gallons	Resin Lab
TEGORAD 2500	0.44 pounds	Resin Lab
Tetraethylthiuram Disulfide	0.22 pounds	Resin Lab
toluene	1.32 gallons	Resin Lab
Various Methacrylates	1.3 gallons	Resin Lab
Various Non-toxic Dyes	0.11 gallons	Resin Lab
Various Photoinitiators	0.44 gallons	Resin Lab
Various Photopolymer Resins	0.264 gallons	Resin Lab
Vinyl Acetate	6 pounds	Resin Lab
Waste Organic Solvents	4 gallons	Resin Lab

Waste Resin	4 gallons	Resin Lab
Zinc Diethyldithiocarbamate	0.11 pounds	Resin Lab
Hydroquinone	1.1 pounds	Resin Lab
4-Hydroxy, 2,2,6,6-tetramethyl-	0.11 pounds	Resin Lab
4-Piperidinol, 1,2,2,6,6-pentamethyl-	0.11 pounds	Resin Lab
Trimethylolpropane Triacrylate	0.13 gallons	Resin Lab
Pentaerythritol triacrylate	0.02 gallons	Resin Lab
Tripropylene glycol diacrylate	0.26 gallons	Resin Lab
Benzyl-N,N-dimethyldithiocarbamate	0.11 pounds	Resin Lab
Ekaland Tbz	2.2 pounds	Resin Lab
Copper diethyldithiocarbamate	0.055 pounds	Resin Lab
Eastman Omnia	0.13 gallons	Resin Lab
1-ethyl-2-purrolidinone	0.07 gallons	Resin Lab
PANEX® Carbon Fiber	4.4 pounds	Resin Lab

5.8 APPENDIX H- INDUSTRIAL STORM WATER POLLUTION PREVENTION PLAN

APPENDIX C

Stormwater Pollution Prevention Plan Checklist

Please check the appropriate answer for each of the following activities.

DOES YOUR FACILITY		YES	NO	NA
1.	Perform any process or waste treatment activities outdoors?		✓	
2.	Operate a fleet of transportation vehicles?		✓	
3.	Perform any equipment or vehicle maintenance (including mechanical repairs, cleaning, painting, fueling and lubrication) activities outdoors?			✓
4.	Perform any loading or unloading of liquids or dry bulk materials outdoors?		✓	
5.	Store any raw materials, intermediate products, finished products or waste products outdoors?		✓	

For positive responses to any of the above activities, your facility must implement the following stormwater pollution prevention elements within 180 days of the date of issuance of your permit.

HAS YOUR FACILITY		YES	NO	NA
1.	Developed a site map showing the location(s) of the stored transportation vehicles and the other activities above?			✓
2.	Developed a list of all chemicals that may come in contact stormwater?			✓
3.	Extended the implementation of its Spill Prevention Control and Countermeasures plan to the reduction of pollutants in stormwater discharges from the facility?			✓

5.9 APPENDIX I- DEFINATIONS

Definitions used in this Operations Plan are found in the specified locations in this Operations Plan or are set forth below. Definitions that are not capitalized below are not capitalized when used in this Operations Plan.

“**Agents**” is defined in the relevant Venue Lease or Venue License.

“**BMPs**” means Best Management Practice.

“**CCR**” means the California Code of Regulations.

“**CFR**” means the Code of Federal Regulations.

“**City**” means the City and County of San Francisco, a municipal corporation.

“**Commission**” means the San Francisco Port Commission.

“**Environmental Laws**” is defined in the relevant Venue Lease or Venue License.

“**Environmental Regulatory Action**” is defined in the relevant Venue Lease or Venue License.

“**Environmental Regulatory Agency**” is defined in the relevant Venue Lease or Venue License.

“**Environmental Regulatory Approval**” is defined in the relevant Venue Lease or Venue License.

“**Environmental Requirements**” is defined in the relevant Venue Lease or Venue License.

“**EPA**” means the US Environmental Protection Agency.

“**Hazardous Material**” is defined in the relevant Venue Lease or Venue License.

“**Law**” is defined in the relevant Venue Lease or Venue License.

“**Premises**” is defined in the relevant Venue Lease or Venue License.

“**Regulatory Agency**” is defined in the relevant Venue Lease or Venue License.

“**Regulatory Approval**” is defined in the relevant Venue Lease or Venue License.

“**Release**” is defined in the relevant Venue Lease or Venue License.

“**Rules and Regulations**” means the Rules and Regulations, if any, applicable to the Premises, as may be amended from time to time.

“**RWQCB**” means the San Francisco Bay Regional Water Quality Control Board of Cal/EPA, a state agency.

“**Tenant**” means the Party identified as Tenant in the Basic Lease Information.

“**Tenant Vehicle**” is defined in the relevant Venue Lease or Venue License.

“**Tenant Vessel**” is defined in the relevant Venue Lease or Venue License.

“**Venue**” is defined in the relevant Venue Lease or Venue License.

“**Venue Lease**” is defined in the relevant Venue Lease or Venue License.

“**Venue License**” is defined in the relevant Venue Lease or Venue License.

5.10 APPENDIX J- WASTE PLAN (FIRST FLOOR)



Pier 9 Waste Plan

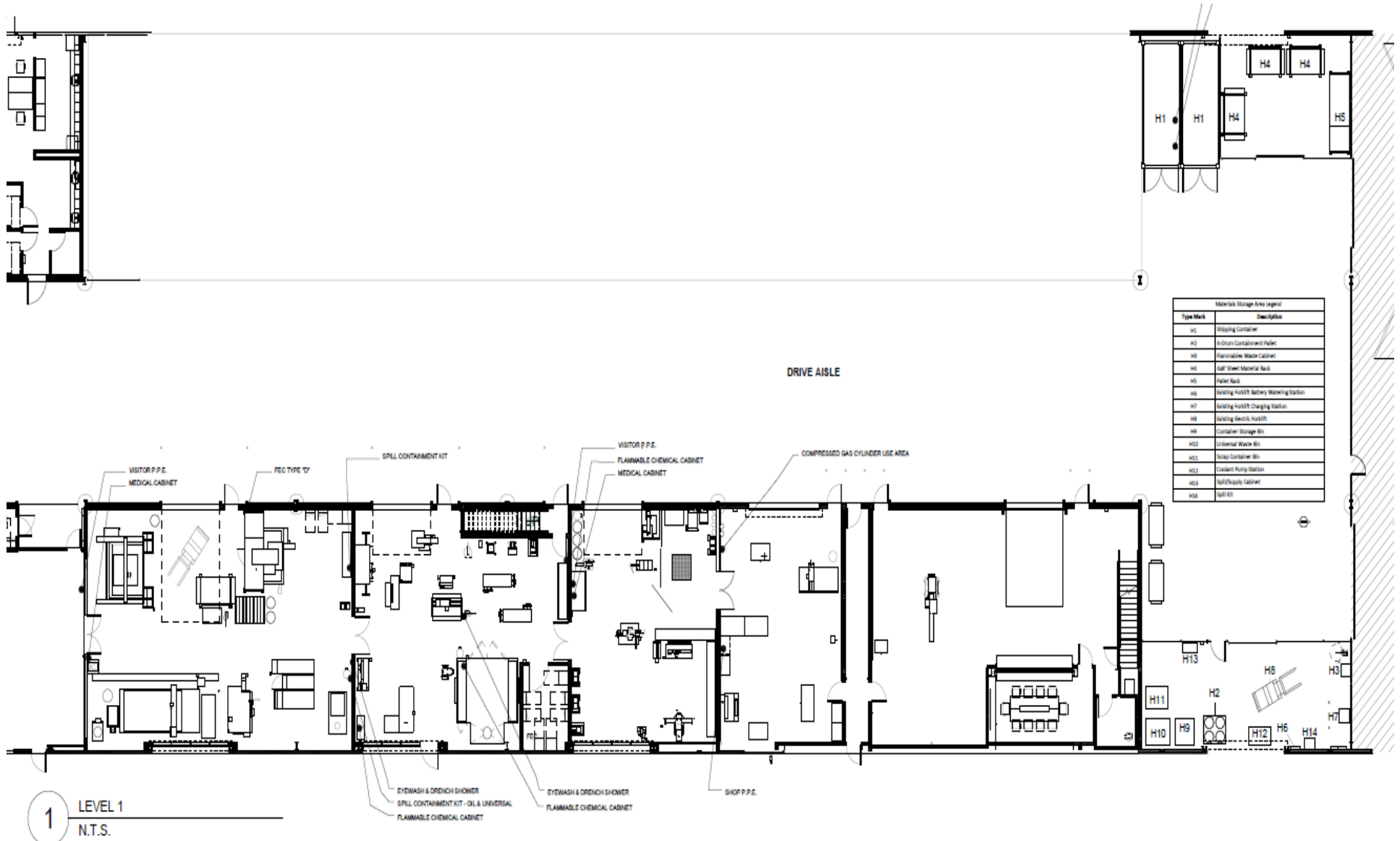

WASTE PLAN (SECOND FLOOR)

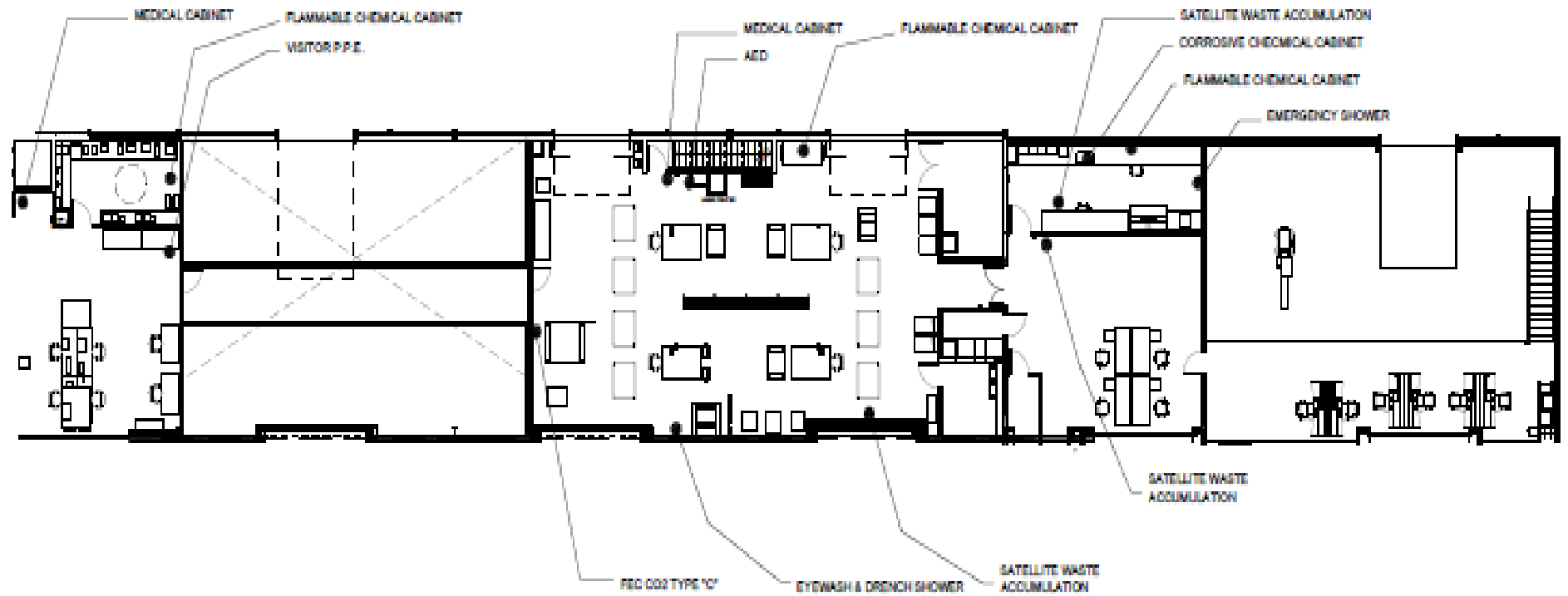

2 MEZZANINE
N.T.S.

5.11 APPENDIX K- STORAGE PLAN

Storage Plan East



Storage Plan West

Storage Plan West



Storage Plan East

Storage Plan-new section



Storage Plan new
section Level 1



Storage Plan-new
section Level 2

5.12 APPENDIX L- SUPPLIES AND DELIVERY PLAN



Shipping and Receiving Plan

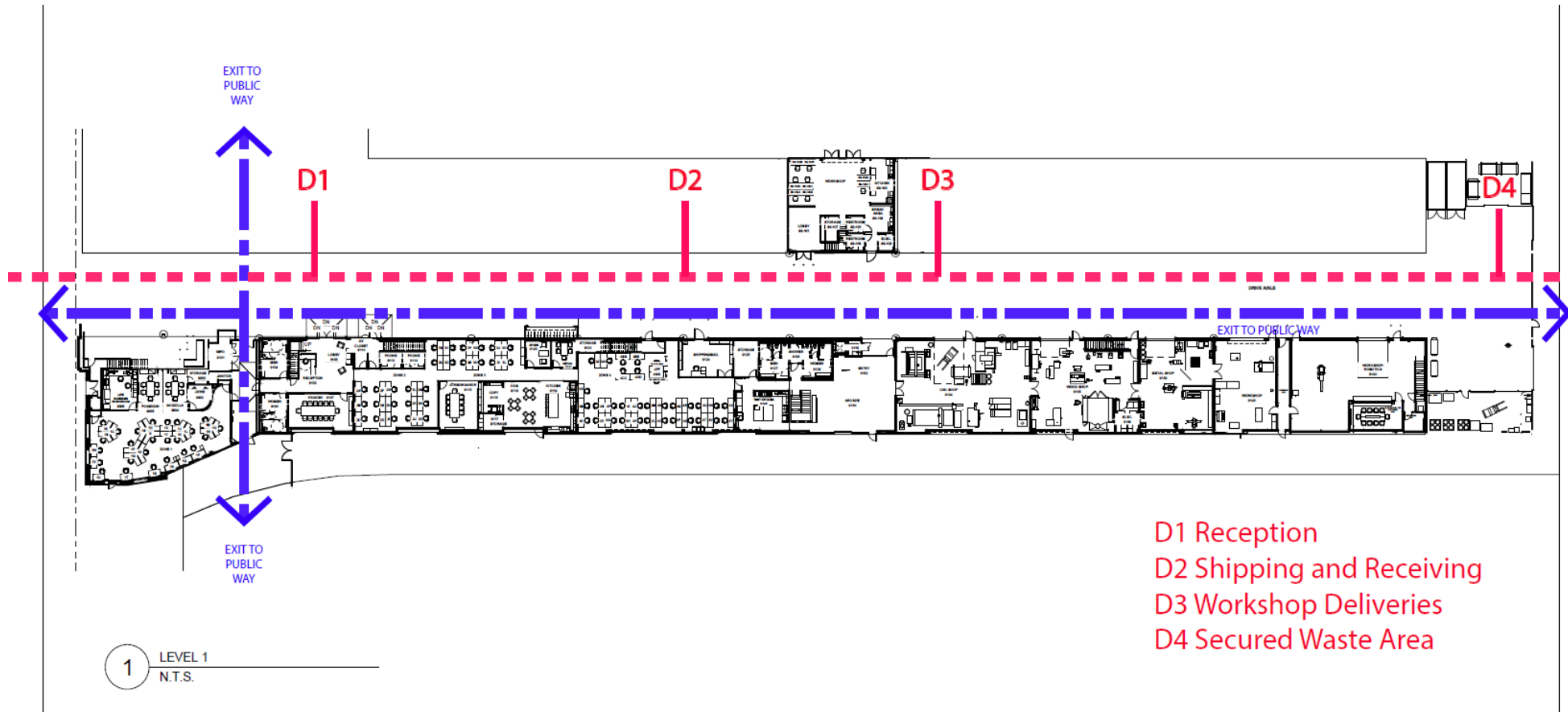





5.13 APPENDIX M-VEOLIA EMERGENCY RESPONSE PLAN



Veolia Emergency
Response Plan

5.14 APPENDIX N- PERMITS

<p>Fire Permit- Hot Works Operations</p>	<p> Fire Permit-Hot Works</p>
<p>Fire Permit-Storage</p>	<p> Fire Permit</p>
<p>HMUPA Certificate</p>	<p> HMUPA Certificate</p>
<p>Wastewater Permit</p>	<p> Wastewater Permit</p>
<p>BAAQMD Air Permit</p>	<p> Air Permit</p>

5.15 APPENDIX O EQUIPMENT INVENTORY

AUTODESK EQUIPMENT INVENTORY			
Description	Manufacturer	Model	Count
CNC SHOP			
DMS 5-Axis enclosed Router	DMS	505-5-5-365	1
Water jet	OMAX	60120	1
Lathe	HAAS	ST-10Y	1
Verticle Mill	HAAS	VF-2SS	1
Tool Setter	Sperroni	MAGIS 400	1
Integrated Mill Turn Center	Mori Seki	NTXI000SZM	1
WOODSHOP			
Table Saw	Sawstop	ICS73480	1
Sliding Compound Miter Saw	Festool Kapex	KS 120	1
Disk Sander	Laguna Tools	A175018	1
Router Table	JESSEM	Mast-R-Lift-Excel II	1
Jointer	Martin	T54	1
Planer	Martin	T45	1
Wood Lathe	One Way	2436	1
Drill Press	Powermatic	PM2800	1
Osciliating Spindle Sander	Laguna Tools	MSANOS14	1
Belt Sander	Powermatic	31A	1
Band Saw	Laguna Tools	MBAND18420	1
METAL SHOP			
Belt Sander	Powermatic	31A	
Pneumatic Bender and Brake	Shop Outfitters	UF-25H	1
Cold Saw	Scotchman	CPO-350	1
Knee Mill	Bridgeport	BPKMR8XY	1
Drill Press	Solberga	SF2025	1
Horizontal Band Saw	Doall	400S	1
Vertical Band Saw	Doall	2013-V	1
Dynastry 350 Tig Welder	Miter	951402	1
Millermatic 252 Mig Welder	Miter	951066	1
Manual Lathe	Sharp		1
PROJECT ASSEMBLY ROOM			
Shopbot		PRSAAlpha 96 x 48	1
Compressor			1
APPLIED RESEARCH LAB			
Ash-MH Configuration	ABB	IRB 6700-205/2.80	1
Castor-A05B-1125-B201	Fanuc	M-710iC/50	1
Pollux-A05B-1125-B201	Fanuc	M-710iC/50	1
UR 10 (Universal Robot)	Bishop		
3D PRINT SHOP			
3D Printer	Stratasys	Objet conex 500	5
Lasercutter	Epilog	Legend 36EXT	4
Coherent Metabeam	Coherent	Metabeam 400W	1
Mcor 3D Paper Printer	Mcor	Iris	1
Roland Versacamm	Roland	SP-540i	1

Ember	Autodesk	Autodesk	6
RESIN LAB			
Mechanical Convection Oven	Thermo Scientific		1
Fridge	Thermo Scientific		1
Viscometer	Brookfield		1
Diaphragm Vacuum Pump	Finematch		1
Spincoater	Specialty Coating Systems		1
TEXTILES AREA			
Industrial Sewing Machine	Juki	DNU-15415	1
Serging Machine	Juki	Mo-6916J-3	1
Industrial Sewing Machine	Bernina	950	1
Sewing & Embroidery Machine	Singer Futura	CE-250	1
TEST KITCHEN			
Gas Range	Wolf	GR606DG	1
Dehydrator	Excalibur	D900SHD	1
Heavy Duty Fryer	Waring	WDF1550	1
LIFE SCIENCE WORK ROOM			
Shaker	Labnet	I-5211-DS	1
Refrigerator	Summit	FF511LB	1
Minus 80 Freezer	Inova	U360	1
Autoclave	Tuttnauer	2540M	1
Benchtop Centrifuge	Thermo Scientific	Heraeus Labofuge 300	1
Micro Centrifuge	Espendorf	54150	1
Vortex Mixer	Fisher Scientific	Heavy Duty VM	1
Waterbath	Thomas	Digital 2L	1
KITCHEN HUB			
Dishmachine	Hobart	LXiH3	1
Ergo Coffee Machine	Ergo		1
Conventional Microwave	Viding	VMos201	2
French Door Refridgerator	LG	LFX28991ST	1
Single Espresso Machine	Rancillo	EPOCA	1
Espresso Grinder-Doser	Rancillo	MD40	1
Vending Module	Automatic Products International	310CM	1
Drink Vending Machine	Dixie-Narco	Bevmax 3	1
Undercounter Refrigerator	U-Line	U-ADA24RS-13	1

Initial :

Port:

Tenant:

SCHEDULE 1

PORT OF SAN FRANCISCO

**ASBESTOS NOTIFICATION AND INFORMATION
NOTICE TO EMPLOYEES,
OWNERS, LESSEES, SUBLESSEES, AGENTS AND CONTRACTORS**

[Attachment on following page(s)]

[PAGE INTENTIONALLY LEFT BLANK]

**NOTICE TO EMPLOYEES,
OWNERS, LESSEES, SUBLESSEES, AGENTS AND CONTRACTORS**

ASBESTOS IN BUILDINGS

FOR PERIOD THROUGH: March 2014

It is the responsibility of the master tenant to provide this notice to any subtenant within their leasehold.

In January of 1989, Assembly Bill 3713 was signed into law and added to the California Health and Safety Code. This bill provides for written notice to employees concerning specific matters related to working in a building with asbestos containing construction materials. It applies to building built before 1979 where the owner knows that the building contains asbestos-containing materials; it does not require that a building be surveyed to determine the presence of asbestos.

WHAT IS ASBESTOS?

Asbestos is a naturally occurring group of fibrous minerals which have been used extensively in public buildings, apartment buildings and homes. Asbestos was incorporated into pipe insulation, acoustic plaster, acoustic tile, duct and furnace insulation, floor tiles, textiles and hundreds of other building materials. In most City buildings, asbestos is located in insulation on piping systems, acoustic plaster on ceilings, acoustic ceiling tiles, vinyl asbestos floor tiles, and structural fireproofing. Asbestos may be found in soils as well, especially if soil is non-native or commingled with municipal waste (land fill).

WHY IS ASBESTOS HAZARDOUS?

Asbestos is a concern because of the potential health risks associated with breathing asbestos fibers. It is important for you to know that most people with asbestos-related diseases were asbestos workers before 1972. These workers were repeatedly exposed to high levels of asbestos each working day with little or no protection. Asbestos workers today are required to follow specific work practices and wear appropriate protection to minimize exposure.

Significant exposure to asbestos fibers can lead to asbestosis and certain forms of cancer. Asbestosis is one of the many dust-related lung diseases. It is associated with chronic exposure to relatively high levels of asbestos and is characterized by the permanent deposition of asbestos fibers in the respiratory tract. The earliest and most prominent clinical finding, breathlessness upon exertion, rarely becomes apparent until at least a decade of exposure.

In addition to asbestosis, the association of asbestos and lung cancer has been well established over the past two decades. Scientists have studied insulation and shipyard workers who were exposed to HIGH AIRBORNE LEVELS of asbestos. These studies indicated that asbestos workers were about five times as likely to get lung cancer as non-asbestos workers who did not smoke. Asbestos workers who also smoke were found to be at much greater risk (about 50 times) of dying of lung cancer than non-smoking non-asbestos workers. Mesothelioma, a rare form of cancer of the chest or abdominal cavity, occurs among occupational groups exposed to certain types of asbestos.

ASBESTOS SAMPLING RESULTS

A variety of exposure standards and health action levels have been established for various purposes:

The Occupational Safety and Health Administration (OSHA) asbestos standards (Title 29 of the Code of Federal Regulations), which apply to employees who actually work with asbestos, mandate a permissible exposure limit (PEL) of 0.1 fibers per cubic centimeter of air (f/cc) determined as an 8 hour time weighted average (TWA) and an excursion limit of 1 f/cc as a 30 minute TWA. When employees are exposed at these levels, OSHA and Cal/OSHA (Title 8 of the California Code of Regulations) require medical monitoring and other control methods.

The Environmental Protection Agency (EPA) has recommended a "clearance level" for asbestos of 0.01 f/cc, as measured by phase contrast microscopy (PCM). If measured by the transmission electron microscopy (TEM) method described in 40 CFR Part 763, the Asbestos Hazard Emergency Response Act (AHERA), the clearance level is either 0.02 structure/cc or 70 structures per square millimeter of filter (s/mm²). This means that once an operation involving asbestos (such as removal) is complete, the area is "safe" for re-occupancy as long as the asbestos air concentrations are less than or equal to the "clearance level". These same levels have also been adopted in the California Education Code (Section 494200.7) as the school abatement clearance level.

The state of California has an additional requirement relating to disclosure of the presence of asbestos. Proposition 65, which as voted into law by the state citizens, basically requires posting of area where anyone is exposed to a carcinogen at a level where there is a significant risk of cancer. The California Health and Welfare Agency has established this level at 100 fibers of asbestos per day.

GENERAL PROCEDURES AND HANDLING RESTRICTIONS

As you can see, the concern is with asbestos fibers in the air. When asbestos materials are in good condition, it is unlikely that fibers will be released into the air, unless the asbestos materials are damaged or disturbed. Asbestos-containing materials must not be disturbed so that fibers do not get into the air. Do not cut into, drill into, nail, or pin anything onto, sand, move bump, rub against or otherwise disturb any asbestos containing materials. If you should discover any damaged asbestos-containing material, do not touch it; do not attempt to clean it up. Contact your supervisor or property manager immediately and report the situation.

City employees required to enter areas and perform work activities that might involve the disturbance of asbestos materials have been trained in the proper procedures to minimize exposure. Work that requires major disturbances of asbestos materials (such as removal) is performed under specifications which include work practice procedures, removal techniques, clean up and clearance air sampling.

If any construction, maintenance, or remodeling is conducted in an area of the building where there is the potential for employees to come in contact with, or release or disturb asbestos containing building materials, it is required that the area be posted with a clear and conspicuous warning sign. The warning sign must read:

**"CAUTION. ASBESTOS
CANCER AND LUNG DISEASE HAZARD
DO NOT DISTURB WITHOUT PROPER TRAINING AND EQUIPMENT"**

Much of this information may be new to you. If you have questions about asbestos, you may call the Department of Public Health Bureau of Environmental Health Management at 252-3800.

This written announcement fulfills the asbestos notification requirement of Division 20, Chapter 10.4, Section 25915 of the California Health and Safety Code (Assembly Bill 3713).

SITE SPECIFIC INFORMATION

At this time, the Port has not sampled for asbestos in your building. The following materials, if present in your building, are assumed to contain asbestos and should be treated as such:

Insulation on pipes and ducts; Fireproofing; Drywall and associated taping compound; Plaster; Texturing or acoustic materials on walls or ceilings; Stucco; ceiling tiles; floor tiles or sheet flooring; roofing; fire door core insulation; carpet, baseboard, flooring, and ceiling tile mastics; window glazing compound; ceramic tile grout and mastic. Asbestos may also be found in soil due to natural or man-made conditions.

These materials must not be drilled into, sanded, demolished or otherwise disturbed by unauthorized personnel. Prior to any renovation activities or other activities which may disturb asbestos, please contact your property manager.

The asbestos coordinator for this building is Tim Felton, who can be reached at 274-0582.

Initial :

Port:

Tenant:

DS
SF

SCHEDULE 2
SUBSTRUCTURE REPORT(S)

[Attachment on following page(s)]

[PAGE INTENTIONALLY LEFT BLANK]



RAPID STRUCTURAL ASSESSMENT REPORT

Structure Type:	SUBSTRUCTURE	Work Order:	18609
Facility Name:	Pier 9 Substructure	FIN:	1090SUB
Asset Number:	1090-SUB3	Facility Code:	1090
Asset Activity:	SUBSTRUCTURE 2 YR INSPECTION	Port Engineer:	Bell, Mr. Jonathan Matthew N
Inspection Number:	1090-SUB3-1-2017	Inspected By:	Port of San Francisco
Inspection Start Date:	2017/02/01 09:00:00	Inspection End Date:	2017/02/01 10:00:00
Purpose Of Inspection:	Periodic Inspection	Lease Number:	
Address:			
Year Built:	1936		

Rating Criteria:

Green - Unrestricted use. May require some minor repair, or minimal barricading.

Yellow With Green Hatching - Restricted use. May require further review, may require load limits, limiting access and barricading until repairs completed.

Red - Unsafe notice. Shall be barricaded to prevent public access and use.

Overall Rating: **Green**

Immediate Actions: No

Required Repairs: Repair spalled concrete deck and beams under north end of bulkhead building. Replace broken fender pile.

Load Limits: No

Barricades: No

Condition Assessment Summary

Condition	Yes	No	More Review Needed
1) Severe Seawall Failure		X	
2) Many Missing Piles		X	
3) Many significant damaged pile		X	
4) Significant beam deterioration		X	
5) Significant slab deterioration		X	
6) Other Hazard present		X	

Comments:

Sequence - 1

Description - Inspector Comment

Comment - Port of San Francisco engineer inspected Pier 9 substructure 2/1/2017. The inspection was made via boat and there was no below water inspection. Water level at time of inspection was approximately +2 ft MLLW. This inspection is for the main pier substructure and does not include the timber aprons.

Pier 9 is a concrete finger pier constructed in 1936. Piles are driven wood piles surrounded by precast grouted concrete jackets from bottom of deck to below the mudline elevation. There are wood aprons along the north and south edges of the pier. A bulkhead building and a shed building are supported above the substructure.



RAPID STRUCTURAL ASSESSMENT REPORT

Overall substructure rating is Green - Unrestricted Use.

The portion of the pier supporting the bulkhead building and marginal wharf near the sea wall is a concrete slab with beams and girders between piles. This area has had widespread shotcrete repairs which are mostly in serviceable condition. The bulkhead substructure north of the rail track is in the worst condition, with a fair number of slab and beam spalls due to corroding rebar. The damage is not severe or widespread enough to warrant and reduced load rating at this time. However, repairs to the concrete spalls are recommended. Concrete pile jackets in this section are in serviceable condition.

The main portion of the pier is a concrete slab with girders running north-south along the pile grid lines. The slab was coated with waterproofing paper. The waterproofing paper is now in poor condition but it appears to have protected the concrete. Many other piers constructed in the 1930s have similar construction. Concrete pile jackets in this section are in serviceable condition. There have been some newer concrete beams added near the southern edge of the pier (Photo 14). Drawings could not be located for this work, but they appear to have been added recently.

Batter piles are located along the north and south edges of Pier 9. These are wood piles with concrete jackets. Batter piles were designed to resist lateral loads from vessel berthing. Several of these piles have shear failures at the connection to the pier deck (Photo 10), but their failure does not significantly affect the gravity load capacity of the pier. Their contribution to the seismic resistance of the pier deck is limited since batter piles tend to fail in compression before vertical piles fail in flexure. No repairs to these batter piles are recommended. Most of the shear failures are in the north-east quadrant of the pier.

The concrete sea wall adjacent to Pier 9 is in serviceable condition, no significant damage was noted.

Attachments:

Appendix A - Facility Data

Appendix B - Photographs and Structural Rating Map



RAPID STRUCTURAL ASSESSMENT REPORT

Appendix A - Facility Data

Substructure/Foundation Data:

Substructure FIN: 1090SUB

Piling Type: Wood with Concrete Jacket

Substructure Deck Type: Concrete

Apron Type: Wood

Detailed Substructure Description (If available):



RAPID STRUCTURAL ASSESSMENT REPORT

Appendix B - Photographs and Structural Rating Map



Photo 1. Outer end of pier



RAPID STRUCTURAL ASSESSMENT REPORT

Appendix B - Photographs and Structural Rating Map



Photo 2. Typical condition of sea wall adjacent to Pier 9. No significant damage noted.



RAPID STRUCTURAL ASSESSMENT REPORT

Appendix B - Photographs and Structural Rating Map



Photo 3. Typical conditions of marginal wharf under bulkhead building. Previous shotcrete repair in serviceable condition, some hairline cracks and scour.



RAPID STRUCTURAL ASSESSMENT REPORT

Appendix B - Photographs and Structural Rating Map



Photo 4. Northern rail track at upper right, concrete surface coated in waterproofing paper.



RAPID STRUCTURAL ASSESSMENT REPORT

Appendix B - Photographs and Structural Rating Map



Photo 5. Deck under north end of bulkhead building has more spalls in shotcrete repair due to rebar corrosion



RAPID STRUCTURAL ASSESSMENT REPORT

Appendix B - Photographs and Structural Rating Map



Photo 6. One concrete beam noted with severe spalling. Does not appear to have ever been repaired with shotcrete.



RAPID STRUCTURAL ASSESSMENT REPORT

Appendix B - Photographs and Structural Rating Map



Photo 7. Minimal section loss at the concrete pile jackets near the waterline



RAPID STRUCTURAL ASSESSMENT REPORT

Appendix B - Photographs and Structural Rating Map



Photo 8. Typical condition of concrete deck. Old waterproofing paper is in varied condition, but appears to have protected the concrete.



RAPID STRUCTURAL ASSESSMENT REPORT

Appendix B - Photographs and Structural Rating Map



Photo 9. One broken fender pile on northern edge of pier near bulkhead building.



RAPID STRUCTURAL ASSESSMENT REPORT

Appendix B - Photographs and Structural Rating Map



Photo 10. Conditions inside northern edge of pier. Many batter piles are broken in the north-east quadrant of the pier. Broken batter piles do not affect gravity load capacity of pier.



RAPID STRUCTURAL ASSESSMENT REPORT

Appendix B - Photographs and Structural Rating Map



Photo 11. Concrete pile jackets along eastern edge of pier (looking north)



RAPID STRUCTURAL ASSESSMENT REPORT

Appendix B - Photographs and Structural Rating Map



Photo 12. Typical conditions of concrete deck and concrete pile jackets along centerline of pier.



RAPID STRUCTURAL ASSESSMENT REPORT

Appendix B - Photographs and Structural Rating Map



Photo 13. New concrete beams added along near south edge of pier. Could not locate drawings for this work.



RAPID STRUCTURAL ASSESSMENT REPORT

Appendix B - Photographs and Structural Rating Map



Photo 14. Typical conditions along southern edge of pier.



RAPID STRUCTURAL ASSESSMENT REPORT

Appendix B - Photographs and Structural Rating Map

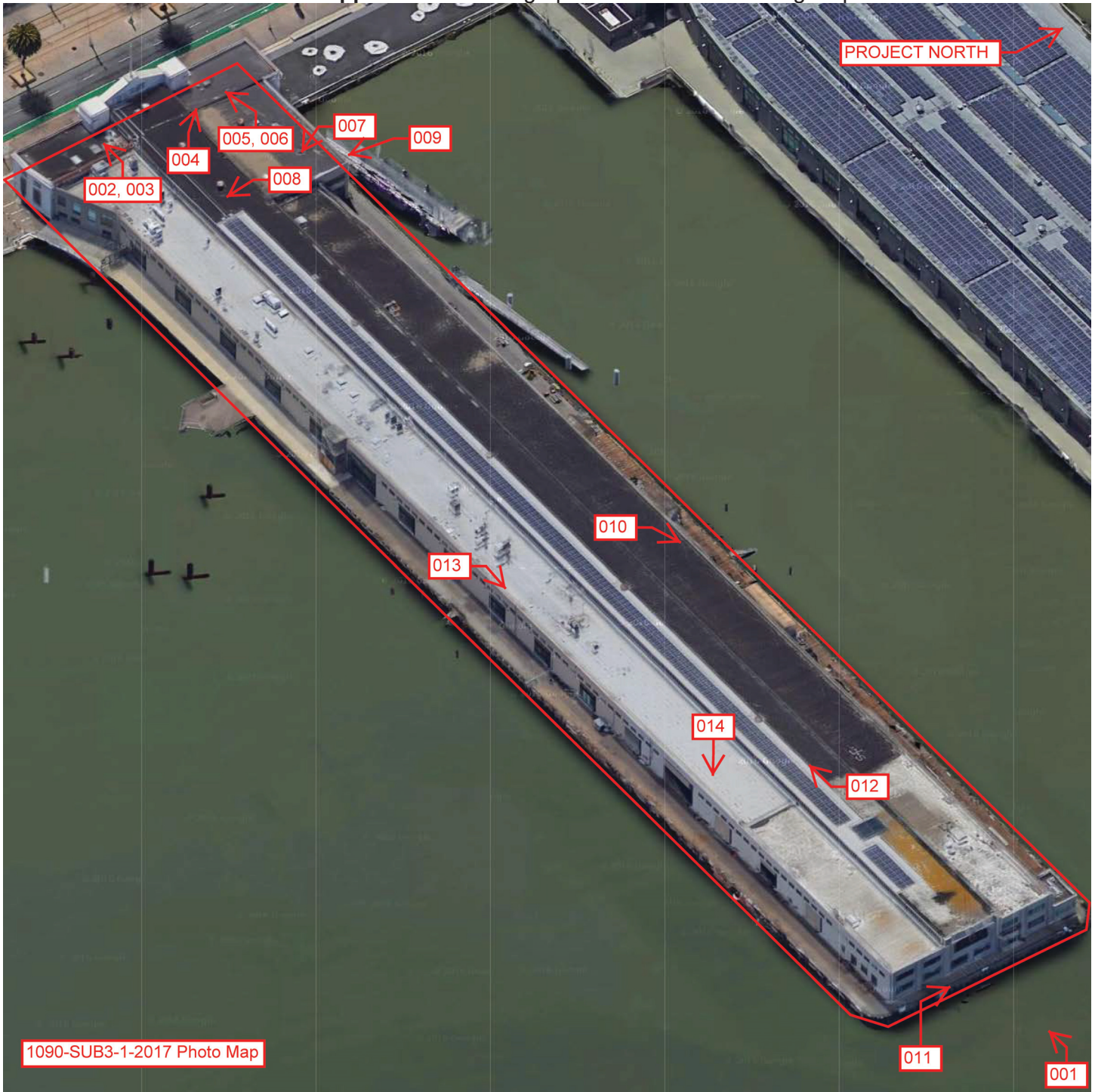

Photo 15. Photo map for Pier 9 substructure inspection



RAPID STRUCTURAL ASSESSMENT REPORT

Appendix B - Photographs and Structural Rating Map

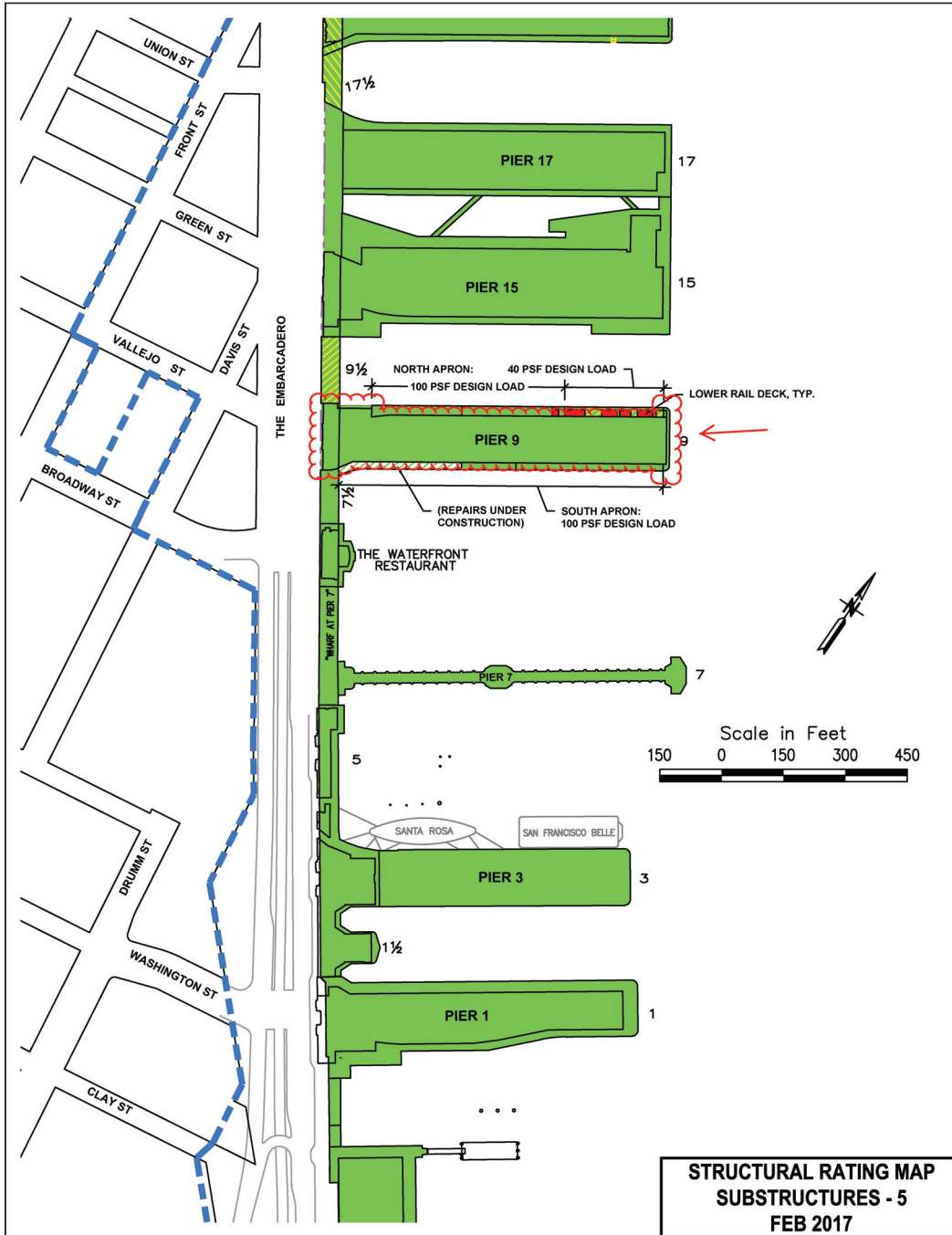

Photo 16. Substructure rating map updated for Pier 9 only.

Initial :

Port:

Tenant:

DS
SF

SCHEDULE 3

04/12/2021

FEMA-National Flood Insurance Program Disclosure Notice

As part of the National Flood Insurance Program (“NFIP”), Federal Emergency Management Agency (“FEMA”) issued the final flood insurance rate maps (“FIRMs”) for City and County of San Francisco on September 23rd, 2020, concluding a process that had been going on for more than a decade. This is the first time FEMA mapped flood risks for the City and County of San Francisco. FIRMs were later adopted by the Board of Supervisors through Ordinance 226-20 (“Floodplain Management Program Ordinance”) and became effective on March 23, 2021.

Based on detailed studies of coastal flood hazards associated with San Francisco Bay and the Pacific Ocean, the final FIRMs designate portions of the City and County of San Francisco (“City”), including portions of the waterfront, Mission Bay, Islais Creek, Bayview Hunters Point, Hunters Point Shipyard, Candlestick Point, Treasure Island, San Francisco International Airport, and Ocean Beach, in coastal flood hazard areas. Referred to as “Special Flood Hazard Areas” (“SFHAs”), these areas are subject to inundation during a flood having a 1 percent chance of occurrence in any given year. They are shown as zones beginning with the letter “A” or “V” on the FIRMs. Port’s structures over water, including piers and wharfs, are designated as Zone D (area of undetermined flood hazard). Zone D areas are not subject to Building Code and NFIP regulation. Historic structures are also exempted from compliance under the NFIP.

Additionally, the San Francisco Public Utilities Commission (“SFPUC”) has prepared the 100-Year Storm Flood Risk Map to show areas where flooding is highly likely to occur on City streets during a 100-year rain storm. More information about this map, including a searchable web map, is available at <https://www.sfwater.org/floodmaps>. The SFPUC 100-Year Storm Flood Risk Map only shows flood risk from storm runoff and, floodproofing measures are not required at this time.

The SFPUC map does not consider flood risk in San Francisco from other causes, such as inundation from the San Francisco Bay or the Pacific Ocean, which are shown on the FIRMs that FEMA has prepared for San Francisco. Conversely, the FIRMs do not show flooding from storm runoff in San Francisco, because our historical creeks and other inland waterbodies have been built over and are no longer open waterways. In most areas, the flood hazards identified by SFPUC and FEMA are separate. There are a few areas, however, near the shoreline where SFPUC’s Flood Risk Zones overlap with the FEMA-designated floodplains.

The FIRM provides flood risk information for flood insurance and floodplain management purposes under the NFIP. The SFHAs, shown on the FIRM, may impact flood insurance requirements and rates, permitting, and building requirements for tenants and permit holders for property in designated SFHAs on the FIRM. Flood insurance is available through the NFIP and the private market. Flood insurance for Zone D areas is not available through NFIP. Pre-FIRM buildings of any type are not required to buy flood insurance. For more information on purchasing flood insurance, please contact your insurance agent.

City’s Floodplain Management Program ordinance is based on NFIP requirements. Under the ordinance, the Port and the City must regulate new construction and substantial improvements or repairs to structures in SFHAs to reduce the risk of flood damage. The requirements may include elevation or floodproofing of structures and attendant utilities.

Additional information on this matter are available on the City/Port websites and FEMA website as listed below-

San Francisco Floodplain Management Program website:
<https://onesanfrancisco.orgisan-francisco-floodplain-management-program>

Port Floodplain Management Program Website:
<https://sfport.com/flood-plain-management-program>

FEMA's NFIP website:
www.FloodSmart.gov.

Initial :

Port:

Tenant:  ^{DS}

SCHEDULE 4
HAZARDOUS MATERIAL DISCLOSURE

Environmental Reports and Documents Regarding Hazardous Materials

Autodesk

February 17, 2022

Pier 9

Final Hazardous Material Inspection Report; Autodesk Tenant Space; Pier 9, Van Brunt Associates, January 2, 2013.

Hazardous Materials Inspection Report; Parcel A, Suite 116; Parcel B, Bays 1 through 3; Pier 9, Van Brunt Associates, September 5, 2012.

Infrared thermal imaging report; Pier 9 Bldg 116, Environmental Services, 2/24/2010.

Mold Inspection Report; Limited Microbial Investigation; Pier 9 Bldg 116, Environmental Services, February 26, 2010.

Port of San Francisco and Tenants, Annual Group Evaluation Report (Stormwater), 2012/2013, Port of San Francisco, 2012/2013.

Port of San Francisco and Tenants, Annual Group Evaluation Report (Stormwater), 2013/2014, Port of San Francisco, June 16, 2014.

Preliminary Mold Inspection Report; Pier 9; Building 116, ProTech Consulting and Engineering, April 2010.

Tenant Improvement/Renovation Asbestos and Lead Inspection Pier 9, Van Brunt Associates, February 13, 2001.

Initial :

Port: _____

Tenant: _____

DS
SF



MEMORANDUM

November 4, 2022

TO: MEMBERS, PORT COMMISSION
Hon. Hon. Willie Adams, President
Hon. Kimberly Brandon, Vice President
Hon. John Burton
Hon. Gail Gilman
Hon. Steven Lee

FROM: Elaine Forbes
Executive Director 

SUBJECT: Request approval of a proposed new lease with Autodesk, Inc., a Delaware corporation ("Autodesk"), for approximately 30,590 square feet of office space and unimproved shed space located at Pier 9 for a term of 12-months with one 12-month option to extend, subject to Board of Supervisor's approval

DIRECTOR'S RECOMMENDATION: Approve the Attached Resolution No 22-53

EXECUTIVE SUMMARY

The Port Commission heard an informational presentation on this topic on October 11, 2022, with additions indicated in underline below.

Port and Autodesk entered-into Port lease No. L-15169 which commenced on October 1, 2012, will expire on January 22, 2023, and has a monthly lease rate of \$51,753.97. As Autodesk's staff have the ability to telecommute, Autodesk is not sure of its ongoing office needs and is only willing to enter a 12-month lease with a 12-month option to extend to retain this space.

Port and Autodesk wish to enter a new lease with terms as described below and outlined in proposed Lease L-16848 (the "Lease"). This is being brought to the Port Commission because the Lease will generate more than \$1 million (\$1,494,090) in Rent for the initial 12-month term with total estimated Rent equaling \$3,032,636 if the extension is exercised.

The proposed Lease incorporates Autodesk's use of solar panels, currently covered under License No. 15698, which will be terminated on the commencement of the Lease. In addition, the "barnacle- themed" concrete seating structures constructed by Autodesk on the marginal wharf between Pier 9 and Pier 15 currently covered under a Management Agreement dated July 8, 2014, has been incorporated into the Lease. The Management Agreement will be terminated upon commencement of the Lease.

STRATEGIC OBJECTIVE

The proposed Lease supports the Strategic Plan goal of Stability by maintaining a rent-paying tenant in place for at least 12 more months with a material rent increase.

BACKGROUND

About the Tenant

Autodesk is an American multinational corporation that focuses on 3D design software for use in the architecture, engineering, construction, manufacturing, media, and entertainment industries.

Autodesk was founded in 1982 by John Walker, a co-author of the first version of the company's flagship CAD software product. Autodesk software has been used in the design of everything from the New York Freedom Tower to Tesla electric cars.

Autodesk has been a Port tenant in Pier 9 since 2012 and spent more than \$3 million on improvements. Autodesk enclosed unimproved shed space to construct a workshop, including installation of non-permeable floors, wall construction, installation of floor to ceiling windows, replacement of doors and windows, installation of new HVAC and electrical and data systems, installation of an elevator, and ADA upgrades.

Autodesk pays as agreed and generally in advance.

Autodesk Financials

Autodesk's balance sheet as of July 31, 2022 shows \$8.2 billion in assets, including slightly more than \$1.5 billion in cash and marketable securities. Liabilities, total \$3.8 billion (before common stock and accumulated losses and deficit) indicating a strong financial position.

On April 9, 2022, Moody's Investor Service upgraded Autodesk's senior unsecured rating to A3, up from Baa2 and said their outlook is "stable". A3 is a "medium" investment grade credit rating

Autodesk's strong financial statements, investment grade credit rating, and Port payment history indicate low risk of a financial default.

STAFF ANALYSIS

The Lease is being brought before the Port Commission because the total rent paid will exceed \$1 million over the lease term. All other terms, conditions, including rental rate, conforms to the Port Commission’s approved FY 22/23 parameter terms and conditions. This lease also requires approval by the City’s Board of Supervisors under Charter Section 9.118 due to the anticipated rent revenue exceeding \$1 million over the term of the Lease.

The Lease encompasses the Solar License and the Maintenance Agreement for the Public Access Parcel into one document, eliminating the need to administer three agreements.

Autodesk has three other leases with the Port as identified below:

- L-16611 – 1,668 square feet of office and storage space in Pier 9
- L-16612 – 6,383 square feet of storage space in Pier 19
- L-16711 – 3,454 square feet of office space in Pier 9, Suite 117

The above leases all expire on December 31, 2022. Port Staff and the City Attorney’s office are actively working on the lease renewals and the expiration dates will be coterminous with the expiration date of the Lease. The Lease will contain a cross default provision so a default under one lease is a default for all.

PROPOSED LEASE TERMS

The schedule below is an outline of the important terms and conditions of the Lease.

Tenant:	Autodesk, Inc. a Delaware corporation
Lease Number:	L-16848
Premises, Solar License Area, and Public Access Area:	Parcel A: approximately 12,064 square feet of ground floor office space and 9,266 square feet of second floor office space. Parcel B: approximately 5,860 square feet of ground floor office space hereto. Parcel C: approximately 3,400 square feet of shed space Solar License Area: Approximately 6,622 rentable square feet of roof space on Pier 9 above the Premises Public Access Area: Approximately 6,594 square feet on the marginal wharf located between Pier 9 and

	Pier 15, including barnacle themed seating structures.
Term:	12 months
Permitted Use:	<p><u>Parcels A and B:</u> Office, research and development and workshop space uses, and all related legal uses. The workshop space use shall include the placement and operation of machinery and equipment, including, without limitation, mills, lathes, drill press, circular saw, scroll saw, laser cutter, welder and the like, and maintenance, repair and replacement of such equipment.</p> <p><u>Parcel C:</u> Research and development and workshop space.</p> <p><u>Solar License:</u> Approx. 6,622 rentable square feet of roof space on the facility together with all improvements and alterations.</p> <p>Tenant has the right to enter and use the Solar License area to maintain, repair, and remove solar panels, together with related equipment, inverters, mountings, and support on the area of the roof of the facility at their own cost.</p>
Lease Commencement Date:	Upon the full execution of the Lease which is subject to Port Commission and Board of Supervisors approval
Rent Commencement Date:	Upon the full execution of the Lease which is subject to Port Commission and Board of Supervisors approval,
Option to Extend Term	Autodesk shall have one Option to Extend for an additional 12-months at the stated rent structure.
Initial Monthly Rent:	\$124,507.50 per month
Monthly Rent During Extended Term:	\$128,212.20 per month
Security Deposit:	Two Hundred Forty-Nine Thousand Fifteen Dollars (\$249,015.00)

<p>Public Access Parcel:</p>	<p>Tenant constructed public amenities on approximately 6,594 square feet on the marginal wharf located between Pier 9 and Pier 15. The amenities are primarily “barnacle-themed” pre-cast concrete seating structures and wharf railing. Autodesk agreed to pay Port \$3,000 per month for Port to provide routine cleaning and maintenance.</p> <p>This Lease will incorporate terms from the existing Maintenance Agreement for such area and improvements. The Maintenance Agreement will be terminated effective on Commencement of the Lease.</p>
<p>Cross Default:</p>	<p>A default under any of the following agreements is a default under the Lease:</p> <p>Lease L-16611 dated as of May 29, 2020. Approximately 1,668 square feet of office and storage space in Pier 9.</p> <p>Lease L-16612 dated May 29, 2020. Approximately 6,383 square feet of storage space in Pier 19.</p> <p>Lease L-16711 dated as of January 21, 2021. Approximately 3,545 square feet of office space in Pier 9, Suite 117</p>
<p>Holding Over:</p>	<p>Holdover rent with Port consent is 150% of base rent and without consent 200% of base rent.</p>
<p>Insurance:</p>	<p>Tenant shall provide insurance coverage as required under the terms of the Lease.</p>
<p>Form Lease; City Requirements:</p>	<p>The Lease shall be on Port’s form lease and include all standard Hazardous Materials, Insurance, Indemnity and Release, Damage and Destruction and all current City ordinances and requirements as necessary.</p>
<p>Termination of Existing Agreements:</p>	<p>The parties agree that as of the Commencement Date, Lease No. L-15169 dated as of September 12, 2012, as amended, is terminated</p> <p>The parties agree that as of the Commencement Date, License No. 15698 (Solar Panels) dated as of August 20, 2013, is terminated.</p> <p>The parties agree that as of the Commencement Date, the Public Access Maintenance Agreement dated as of July 8, 2014, as amended, is terminated.</p>

RECOMMENDATION

Port staff recommends that the Port Commission approve the attached resolution authorizing the Executive Director to enter into proposed Lease No. L-16848 with Autodesk, Inc. a Delaware corporation, and authorize the Executive Director to forward the Lease to the Board of Supervisors for approval and upon the effectiveness of such approval, authorize the Executive Director or designee to execute the Lease.

Prepared by: Don Kavanagh, Senior Property Manager
Vicky Lee, Property Manager

For: Rebecca Benassini
Deputy Director Real Estate and Development

PORT COMMISSION
CITY AND COUNTY OF SAN FRANCISCO
RESOLUTION NO. 22-52

- WHEREAS, Charter Section B3.581 empowers the Port Commission with the power and duty to use, conduct, operate, maintain, manage, regulate and control the Port area of the City and County of San Francisco; and
- WHEREAS, Autodesk, Inc. is a tenant in good standing under its current leases located at Piers 9 and 19, in the City and County of San Francisco; and
- WHEREAS, Port Staff has negotiated the terms of a new 12 month lease with one (1) 12 month option to extend for space at Pier 9 consisting of approximately 27,190 square feet of office space, approximately 3,400 square feet of shed space, and including a license for approximately 6,622 square feet of roof space and a license for approximately 6,594 square feet on the marginal wharf located between Pier 9 and Pier 15, for collective use as office, research and development, workshop space and public art display and public access as described in the Memorandum to the Port Commission dated November 4, 2022; and
- WHEREAS, The use is a continuation of existing and related uses and is therefore not a project subject to review under the California Environmental Quality Act; and
- WHEREAS, Port staff recommends approval of a proposed new lease with Autodesk which will generate revenues of approximately \$124,507.50 per month; and now therefore be it
- RESOLVED, The Port Commission hereby approves the terms of proposed Lease L-16848 with Autodesk, Inc. for a 12 month lease with one (1) 12 month option to extend for approximately 27,190 square feet of office space, approximately 3,400 square feet of shed space, approximately 6,622 licensed square feet of roof space and approximately 6,594 licensed square feet on the marginal wharf located between Pier 9 and Pier 15 for use as office, research and development, workshop space and public access as described above and authorizes the Executive Director or her designee to forward the Lease to the Board of Supervisors (“Board”) for approval, pursuant to the Board’s authority under Charter Section 9.118, and upon the effectiveness of such approval, to execute the Lease; and be it further
- RESOLVED, that the Port Commission authorizes the Executive Director or her designee, to enter into any additions, amendments or other modifications to the Lease that the Executive Director, in consultation with the City Attorney, determines are in the best interest of the Port, do not materially

increase the obligations or liabilities of the Port or materially decrease the public benefits accruing to the Port, and are necessary and advisable to complete the transaction and effectuate the purpose and intent of this Resolution, such determination to be conclusively evidenced by the execution and delivery by the Executive Director of any such documents.

I hereby certify that the foregoing resolution was adopted by the Port Commission at its meeting of November 8, 2022.

DocuSigned by:
Carl Nista
BFA59E31E3B84A8...

Secretary



San Francisco Ethics Commission

25 Van Ness Avenue, Suite 220, San Francisco, CA 94102

Phone: 415.252.3100 . Fax: 415.252.3112

ethics.commission@sfgov.org . www.sfethics.org

Received On:

File #: 230009

Bid/RFP #: L-16848

Notification of Contract Approval

SFEC Form 126(f)4

(S.F. Campaign and Governmental Conduct Code § 1.126(f)4)

A Public Document

Each City elective officer who approves a contract that has a total anticipated or actual value of \$100,000 or more must file this form with the Ethics Commission within five business days of approval by: (a) the City elective officer, (b) any board on which the City elective officer serves, or (c) the board of any state agency on which an appointee of the City elective officer serves. For more information, see: <https://sfethics.org/compliance/city-officers/contract-approval-city-officers>

1. FILING INFORMATION

TYPE OF FILING	DATE OF ORIGINAL FILING (for amendment only)
Original	
AMENDMENT DESCRIPTION – Explain reason for amendment	

2. CITY ELECTIVE OFFICE OR BOARD

OFFICE OR BOARD	NAME OF CITY ELECTIVE OFFICER
Board of Supervisors	Members

3. FILER'S CONTACT

NAME OF FILER'S CONTACT	TELEPHONE NUMBER
Angela Calvillo	415-554-5184
FULL DEPARTMENT NAME	EMAIL
office of the clerk of the Board	Board.of.Supervisors@sfgov.org

4. CONTRACTING DEPARTMENT CONTACT

NAME OF DEPARTMENTAL CONTACT	DEPARTMENT CONTACT TELEPHONE NUMBER
Don Kavanagh	415.274.0501
FULL DEPARTMENT NAME	DEPARTMENT CONTACT EMAIL
PRT Port of San Francisco	don.kavanagh@sfport.com

5. CONTRACTOR	
NAME OF CONTRACTOR Autodesk, Inc.	TELEPHONE NUMBER 415.233.8958
STREET ADDRESS (including City, State and Zip Code) Pier 9, San Francisco, CA 94111	EMAIL melissa.boykin@autodesk.com

6. CONTRACT		
DATE CONTRACT WAS APPROVED BY THE CITY ELECTIVE OFFICER(S)	ORIGINAL BID/RFP NUMBER L-16848	FILE NUMBER (If applicable) 230009
DESCRIPTION OF AMOUNT OF CONTRACT Rent >\$1 million over the lease term		
NATURE OF THE CONTRACT (Please describe) This is a renewal lease for Autodesk, Inc. at Pier 9 in San Francisco for a one-year term plus a one-year option. Scheduled initial monthly rent is \$124,508. If the option is exercised the rent increases to \$128,212 per month.		

7. COMMENTS

8. CONTRACT APPROVAL	
This contract was approved by:	
<input type="checkbox"/>	THE CITY ELECTIVE OFFICER(S) IDENTIFIED ON THIS FORM
<input checked="" type="checkbox"/>	A BOARD ON WHICH THE CITY ELECTIVE OFFICER(S) SERVES Board of Supervisors
<input type="checkbox"/>	THE BOARD OF A STATE AGENCY ON WHICH AN APPOINTEE OF THE CITY ELECTIVE OFFICER(S) IDENTIFIED ON THIS FORM SITS

9. AFFILIATES AND SUBCONTRACTORS

List the names of (A) members of the contractor's board of directors; (B) the contractor's principal officers, including chief executive officer, chief financial officer, chief operating officer, or other persons with similar titles; (C) any individual or entity who has an ownership interest of 10 percent or more in the contractor; and (D) any subcontractor listed in the bid or contract.

#	LAST NAME/ENTITY/SUBCONTRACTOR	FIRST NAME	TYPE
1	Anagnost	Andrew	Board of Directors
2	Blasing	Karen	Board of Directors
3	French	Reid	Board of Directors
4	Howard	Ayanna	Board of Directors
5	Irving	Blake	Board of Directors
6	McDowell	Mary T.	Board of Directors
7	Milligan	Stephen D.	Board of Directors
8	Norrington	Lorrie M.	Board of Directors
9	Rafael	Betsy	Board of Directors
10	Rahim	Rami	Board of Directors
11	Smith	Stacy J.	Board of Directors
12	Anagnost	Andrew	CEO
13	Clifford	Deborah	CFO
14	Blum	Steve	COO
15			
16			
17			
18			
19			

9. AFFILIATES AND SUBCONTRACTORS

List the names of (A) members of the contractor’s board of directors; (B) the contractor’s principal officers, including chief executive officer, chief financial officer, chief operating officer, or other persons with similar titles; (C) any individual or entity who has an ownership interest of 10 percent or more in the contractor; and (D) any subcontractor listed in the bid or contract.

#	LAST NAME/ENTITY/SUBCONTRACTOR	FIRST NAME	TYPE
20			
21			
22			
23			
24			
25			
26			
27			
28			
29			
30			
31			
32			
33			
34			
35			
36			
37			
38			

9. AFFILIATES AND SUBCONTRACTORS

List the names of (A) members of the contractor’s board of directors; (B) the contractor’s principal officers, including chief executive officer, chief financial officer, chief operating officer, or other persons with similar titles; (C) any individual or entity who has an ownership interest of 10 percent or more in the contractor; and (D) any subcontractor listed in the bid or contract.

#	LAST NAME/ENTITY/SUBCONTRACTOR	FIRST NAME	TYPE
39			
40			
41			
42			
43			
44			
45			
46			
47			
48			
49			
50			

Check this box if you need to include additional names. Please submit a separate form with complete information. Select “Supplemental” for filing type.

10. VERIFICATION

I have used all reasonable diligence in preparing this statement. I have reviewed this statement and to the best of my knowledge the information I have provided here is true and complete.

I certify under penalty of perjury under the laws of the State of California that the foregoing is true and correct.

<p>SIGNATURE OF CITY ELECTIVE OFFICER OR BOARD SECRETARY OR CLERK</p> <p>BOS Clerk of the Board</p>	<p>DATE SIGNED</p>
---	---------------------------

From: [Delepine, Boris \(PRT\)](#)
To: [BOS Legislation, \(BOS\)](#)
Cc: [Somera, Alisa \(BOS\)](#)
Subject: Port Introduction - Autodesk Lease
Date: Tuesday, December 6, 2022 11:32:45 AM
Attachments: [Resolution 22-53 Autodesk \(L-16848\) Action_final.pdf](#)
[Execution Autodesk Pier 9 L-16848.pdf](#)
[Port Resolution Board of Sup Autodesk - 12.6.22.docx](#)
[Autodesk - COVER LETTER.doc](#)
[image001.png](#)
[image002.png](#)
[image003.png](#)
[image004.png](#)
[image005.png](#)
[image006.png](#)

Good morning,

Can this resolution be introduced at next Tuesday's BOS meeting (12/13) by the Port or does it need a member's sponsorship to meet next Tuesday's deadline?

Attached is:

- Cover Letter
- BOS draft Resolution for approval of Autodesk lease (word)
- Port Commission Staff Report and resolution approving the lease (pdf)
- Draft Autodesk, Inc., lease L-16848 (pdf)

Form SFEC -126 forthcoming.

Thank you,
Boris



Boris Delepine

Legislative Affairs Manager, Port of San Francisco
415.274.0443 | boris.delepine@sfport.com
Pier 1, The Embarcadero, San Francisco, CA 94111



[Stay up-to-date and sign-up for the Port's digital magazine](#)