

## SHARING AGREEMENT V261S-1583

SECTION I - AGREEMENT AWARD AND ACCEPTANCE		
AGREEMENT NUMBER: V261S-1583		EFFECTIVE DATE: April 1, 2003, subject to enactment of City's Board of Supervisors resolution
AGREEMENT FOR FURNISHING USE OF SPACE AS AUTHORIZED UNDER 38 U.S.C. 8153		
<p>This Sharing Agreement (Agreement) is by and between the Department of Veterans Affairs Medical Center, San Francisco located at 4150 Clement Street, San Francisco, California 94121, hereinafter referred to as VA, and the City and County of San Francisco, a municipal corporation, acting by and through its Emergency Communications Department ("ECD"), hereinafter referred to SHARING PARTNER or CITY, for furnishing Use of Space as described herein.</p>		
<p>1. The Agreement shall be for a ten (10) year period subject to the terms, conditions, cancellation, termination and extension provisions in Section II. This agreement may be renewed for up to two (2) successive five (5) year periods, as identified in Section II D.</p>		
<p>2. This Agreement shall be effective as of April 1, 2003, subject to enactment of City's Board of Supervisor's resolution approving this Agreement on behalf of SHARING PARTNER, and execution by VA Contracting Officer and SHARING PARTNER, and shall end no later than March 31, 2013, subject to extension by options per Section II D (4).</p>		
<p>3. Agreement Monthly Rates are detailed in Section II D.</p>		
<p>4. The parties to this agreement are as follows:</p>		
<p>Department of Veterans Affairs - Medical Center San Francisco (VA) 4150 Clement Street San Francisco, CA 94121</p>	<p>ATTN: Director of Property City and County of San Francisco 25 Van Ness Avenue, Suite 400 San Francisco, CA 94102</p>	
<p>5. The City and County of San Francisco shall forward monthly payments to the attention of the "Agent Cashier" at the VA address identified above.</p>		
<p>6. This document is not binding on the parties unless signed below by authorized representatives of VA and SHARING PARTNER.</p>		
<p>7. VA Authorizing Official:</p>		
<p>a. Name and Title of VA Representative</p> <p>Mark Mikus Contracting Officer</p>	<p>b. Signature of VA Representative</p> <p><b>TERRENCE W. NELSON</b> <i>Terrence W Nelson</i></p>	<p>c. Date</p> <p>9/30/03</p>
<p>8. SHARING PARTNER Authorizing Official Steve Legnitto, Deputy Director of Property</p>		
<p>a. Name and Title of SHARING PARTNER Representative</p> <p>Steve Legnitto, Deputy Director of Property City and County of San Francisco Real Estate Division 25 Van Ness Avenue, 4th Floor San Francisco, CA 94102</p>	<p>b. Signature of SHARING PARTNER Representative</p> <p><i>Steve Legnitto</i></p>	<p>c. Date</p> <p>9/25/2003</p>

## SHARING AGREEMENT V261S-1583

This Sharing Agreement (Agreement) is by and between the Department of Veterans Affairs Medical Center, San Francisco located at 4150 Clement Street, San Francisco, California 94121 (VA) and the City and County of San Francisco, a municipal corporation, acting by and through its ECD (SHARING PARTNER).

## VA Agreement Point of Contact (POC):

Name: Terrence W. Nelson, Contract Specialist

Phone number: (916) 561-7530

Fax Number: (916) 561-7513

Email address: [Terrence.Nelson@med.va.gov](mailto:Terrence.Nelson@med.va.gov)

Note: All references to Contracting Officer refer to the VA Authorizing Official Identified in on Page 1, Block 7, or his/her successor.

## VA Alternate POC if T. Nelson is unavailable:

Name: R. Jolly Brown, Revenue Marketing Team Leader

Phone number: (415) 379-5556

Fax number: (415) 750-2170

Email address: [R.Jolly.Brown@med.va.gov](mailto:R.Jolly.Brown@med.va.gov)

Official Correspondence Address: San Francisco VA Medical Center  
C/O Revenue Marketing Team (90CCA)  
4150 Clement St.  
San Francisco Ca, 94121

## SHARING PARTNER Agreement Point of Contact:

Name: JoAnn Hicks

Phone number: (415) 558-3831

Fax Number: (415) 558-3841

Email address: [joann.hicks@sfgov.org](mailto:joann.hicks@sfgov.org)

## Alternate Point of Contact if POC is unavailable:

Mitchell Sutton

Phone Number: (415) 558-3811

Fax Number: (415) 558-3841

## Official Correspondence Address:

Attn: Director of Property  
City and County of San Francisco  
Real Estate Division  
25 Van Ness Ave., 4th Floor  
San Francisco, CA 94102

JoAnn Hicks  
City and County of San Francisco  
Emergency Communications Department  
1011 Turk St.  
San Francisco, CA 94102

## SHARING AGREEMENT V261S-1583

## SECTION II - TERMS AND CONDITIONS

VA will provide to Sharing Partner the right to use the Space identified below for the placement of radio communications antenna and equipment.

In consideration of the mutual agreements contained herein, the parties hereby agree as follows:

A. AMOUNT AND TYPE OF SPACE:

1. VA will furnish to SHARING PARTNER, use of the following space:
  - a. Space: 800MHz radio communication equipment enclosure, mountings for three antenna, and utility connections as shown on Exhibits A and B attached hereto (the "Space").
  - b. Type/Purpose: Radio Communications Facility and associated antennas and equipment (RCF).
  - c. Location: Department of Veterans Affairs Medical Center San Francisco, San Francisco, CA located at 4150 Clement Street, San Francisco, CA (the "Medical Center").
2. The Space shall to be used exclusively for installation, use, maintenance and repair of the RCF. SHARING PARTNER shall not use the Space for any other purpose without written consent of the Contracting Officer.
3. The amount and type of space as identified above is delineated on the attached drawing(s) as provided by SHARING PARTNER and incorporated herein, and identified as Exhibits A and B.

B. SERVICES, UTILITIES, MAINTENANCE:

1. Utilities:
  - a. The RCF will be connected to the VA electrical grid. This connection will provide 480 Volts of electricity at 70 Amps from the 600 Amp main distribution panel in the electrical room of Building 205 of the Medical Center to the RCF. In the event of an electrical power failure, the VA shall supply power from its backup emergency generator located in Building 205. In the event electrical services are interrupted and SHARING PARTNER is thereby unable to use the RCF, then the fees due and owing hereunder shall be abated on a per diem basis for so long as the electrical services are not provided. The VA shall bear no responsibility or liability of any nature, and shall not be the subject of any claim for damage by the SHARING PARTNER, based upon the interruption of failure of the electrical service, except to the extent caused by VA and as permitted by Federal law. The VA acknowledges that SHARING PARTNER may make a claim for any such interruption in accordance with the procedures set forth below.

## SHARING AGREEMENT V261S-1583

b. The cost for electricity provided to the SHARING PARTNER RCF will be separately metered by the VA and the actual cost of that electricity will be charged to SHARING PARTNER on a monthly bill of collection. The VA will maintain in a safe, complete and organized manner all records for each year's (Year 1, Year 2, etc.) twelve months of charges, pertaining to this Agreement and all such charges paid by SHARING PARTNER pursuant to billings for that twelve month period, for the earlier of the following; 1) a period of not less than twelve (12) months beyond the completion date of that Year, or 2) for twelve (12) months beyond the expiration or termination of this Agreement. This means, for example, that if for a one-year contractual period ending May 31, 2003, the VA will maintain those records until at least May 31, 2004, but is not required to maintain those records beyond those twelve months. The VA shall reasonably make those twelve months of records available for inspection, copying and audit by City and its representatives, at City's expense.

c. VA has the right to terminate utility service to the SHARING PARTNER'S RCF after a monetary default that SHARING PARTNER fails to cure within 30 days after written notice by VA, or a non-monetary default that SHARING PARTNER fails to cure within 30 days after written notice by VA. Such breaches are justification for VA cancellation of this Agreement in accordance with Section II G. 7; provided, however, VA shall not have the right to terminate utility service in the event of a dispute between SHARING PARTNER and VA over the nature or extent of the alleged default, or if SHARING PARTNER has commenced to cure the alleged default and is proceeding to complete the curative action with reasonable diligence.

2. Security Services: VA Police & Security Service will provide security services to the Space, however VA shall accept no liability for loss of or damage to SHARING PARTNER'S property or personal possessions caused by third party intruders.

3. The VA to Maintain Utilities: The VA shall make a "reasonable effort" to repair, protect and maintain, at no cost to the City, the electricity lines and the backup generator serving the RCF. In addition, the VA shall not permit other users of the Medical Center to disturb or interfere with SHARING PARTNER'S use of the Space.

C. ADDITIONAL AGREEMENT REQUIREMENTS:

1. Facility Improvements:

a. VA will not provide any facility improvements.

b. SHARING PARTNER will be responsible for any improvements required prior to or during occupancy. Such improvements will normally be limited to minor cosmetic improvements such as, general surface painting or installation/replacement of carpet. SHARING PARTNER shall not be required to notify, or obtain the VA's prior approval, before making any alterations to the interior of the equipment enclosure.

c. All facility improvements shall comply with applicable Federal, State and Local laws, statutes, regulations and Safety Codes, and applicable VA requirements as reasonably directed by the Contracting Officer and applied in a nondiscriminatory manner. All finishes,



## SHARING AGREEMENT V261S-1583

materials, equipment and methods must match existing, unless approved in writing by the VA Contracting Officer. Plans for any exterior facility improvements, must be coordinated with and approved by the Contracting Officer prior to the SHARING PARTNER beginning such facility improvements.

2. SHARING PARTNER Access to Space: Subject to the VA Access to Space requirement Section II C.10, SHARING PARTNER will have separate key access to subject space. No other person(s) or organization(s) shall have access to the space, except in the conduct of official business as it pertains to SHARING PARTNER or matters such as SHARING PARTNER deems appropriate after full consideration of all laws and agreements governing the operation of said space. The VA shall provide to SHARING PARTNER at all times uninterrupted access to the Space to the maximum extent possible, including, without limitation, during any power outages; provided, however, that the VA may interrupt SHARING PARTNER's access in the event of an immediate threat to the Space or the Medical Center being rendered unsafe for human occupancy. If SHARING PARTNER's use of the Space or access thereto is interrupted for any reason other than SHARING PARTNER's default hereunder, and such condition continues for twenty-four (24) hours, then the rent and other fees payable hereunder shall be abated based on the extent to which such access or use is denied to SHARING PARTNER, upon receipt by VA of written notification by SHARING PARTNER, of the interruption.

3. Telecommunication and Data Equipment: SHARING PARTNER shall be responsible for all charges for installation and maintenance of Telecommunication and Data equipment, lines or services. Lines or services include Telephone, Facsimile and Internet service and the cost of all and any monthly service charges for them. Such charges shall be billed by the provider directly to and paid for by SHARING PARTNER. Telecommunication and Data Installation shall be coordinated with the VA Information Resources Management (IRM) and Engineering Service staff.

4. Signage: SHARING PARTNER is permitted to install signs as required by FCC rules and regulations. The VA has the right to determine the design, materials and location of signage, if to do so will not contravene the rules and regulations of the FCC. The cost of such signage will be included in the rental rate.

5. Election to Rebuild RCF Following Destruction: If the RCF equipment enclosure is totally destroyed by fire or other casualty, the VA will allow SHARING PARTNER forty-five (45) days within which to elect to rebuild the equipment enclosure. If SHARING PARTNER does not make the election to rebuild within the 45-day time period or if SHARING PARTNER decides not to rebuild the equipment enclosure, the Agreement shall be cancelled immediately with no monetary or contractual penalties to either SHARING PARTNER or the VA. Upon request by SHARING PARTNER, VA will make a good faith effort to obtain other suitable space at the Medical Center for SHARING PARTNER's purposes. VA's good faith effort to find suitable space does not guarantee that suitable space will be available or suitable for SHARING PARTNER's purposes. If such space is unavailable or unsuitable for SHARING PARTNER's purposes, the Agreement is cancelled unless SHARING PARTNER elects to rebuild the equipment enclosure at the Space. If SHARING PARTNER is responsible for the fire or other casualty, the Agreement shall remain in force and effect if SHARING PARTNER elects to rebuild the equipment enclosure. If VA is responsible for the fire or other casualty causing loss

## SHARING AGREEMENT V261S-1583

to SHARING PARTNER, SHARING PARTNER may make a claim for damages in accordance with the claim procedures under the Federal Tort Claims Act (62 Stat. 869, 982; 28 U.S.C. 2671-2680) as set forth below.

6. Subleasing: SHARING PARTNER understands and hereby acknowledges that this Agreement is not a leasing agreement and therefore SHARING PARTNER is not authorized to, and shall not sublease the space; provided, however, SHARING PARTNER will have the right, with notice to VA, to assign its rights under this Agreement in whole or in part to: (a) any entity controlling, controlled by or under common control with SHARING PARTNER, including but not limited to the San Francisco Finance Corporation; or (b) any governmental or quasi-governmental agency using the Space for "non commercial" public safety communication purposes.

7. Restoration of Property:

a. On or before the date of expiration or cancellation of this Agreement, SHARING PARTNER shall vacate the Space and remove its personal property and remove any fixtures or equipment and SHARING PARTNER will restore the Space to as good order and condition as that existing upon the date of commencement of the Agreement, ordinary wear and tear and damage by casualty excepted. SHARING PARTNER has ninety (90) days after the end of the term to remove its equipment during which time, SHARING PARTNER would continue to make rental payments for the Space for so long as the equipment is not removed; provided, however, SHARING PARTNER shall not be responsible for such continued payments if the end of the term is the result of a casualty, interruption in utility service, or a default by the VA, in which case SHARING PARTNER shall have ninety (90) days to remove its equipment without any additional payment or fee. As of the date of expiration or cancellation of this Agreement, VA, without liability, has the right to terminate electrical service to the SHARING PARTNER'S RCF.

b. SHARING PARTNER is responsible for the actual cost of repair for damage sustained to the Space as a result of SHARING PARTNER removing equipment or fixtures from the Space, except for any damages beyond the control of SHARING PARTNER or due to reasonable wear and tear. In the event SHARING PARTNER fails to comply with the duties set forth in this paragraph, SHARING PARTNER shall reimburse to VA on demand, the actual cost incurred by the VA to restore the Space after the expiration or cancellation of this Agreement to the condition as stated herein.

c. Nothing in this Agreement is intended to convey to the VA, a real property interest or personal property interest in the equipment shelter or antennas and fixtures used by SHARING PARTNER. It is hereby acknowledged that all SHARING PARTNER equipment, fixtures, and personal property installed at the Space by SHARING PARTNER remains the property of SHARING PARTNER and that SHARING PARTNER will have the right to remove such equipment, fixtures and personal property, whether or not said items are considered fixtures and attachments to real property under applicable law.

## SHARING AGREEMENT V261S-1583

## 8. Compliance with Laws:

a. SHARING PARTNER is responsible for obtaining all applicable state permits and licenses for the RCF. SHARING PARTNER is responsible for payment of any applicable service charges and fees in obtaining such permits and licenses including but not limited to applicable FCC regulations and compliance with the Telecommunications Act of 1996. VA will cooperate with SHARING PARTNER in obtaining governmental approval at no expense to the VA. However, it is SHARING PARTNER's sole responsibility to obtain the appropriate permits/licenses and to pay any applicable fees.

b. SHARING PARTNER shall comply with and follow all applicable rules, laws, ordinances, orders and regulations of the State, county, and municipality unless they are inconsistent with federal law. SHARING PARTNER shall comply with and follow all requirements of the Federal government departments & bureaus wherein the Space is located, with regard to SHARING PARTNER's use of the Space and the RCF.

c. SHARING PARTNER will not use the Space for the sale of alcohol or firearms, gambling activities, partisan political activities, storage or processing of hazardous materials, or other activities determined improper by VA. In addition, the manufacture, distribution, dispensing, possession or use of controlled substances, alcoholic beverages or weapons is prohibited on federal property. Notwithstanding the foregoing, the operation of a communications facility shall not be deemed an improper activity.

d. Federal Acquisition Regulation 52.222-26 Equal Opportunity (Apr 2002) clause is hereby referenced and incorporated in full force. In the clause, the term "Contractor" is hereby replaced with "SHARING PARTNER". VA has provided a copy of this clause to SHARING PARTNER. Any activity, program or use made of the space by SHARING PARTNER shall be in compliance with the provisions of this Equal Opportunity regulation.

## 9. VA Access to Space:

a. As the Space is located on VA property, VA will have access to the Space 24 hours per day, 7 days per week and reserves the right to inspect the Space as necessary in order to furnish any labor, materials or equipment required, on an emergency basis, to maintain the integrity and safety of the Space. VA shall exercise its access rights contained in this section in a manner so as not to unduly disrupt or interfere with the operation of the RCF.

b. For non-emergency purposes, the VA will notify SHARING PARTNER within 48 hours when the VA desires access to the Space during ordinary working hours. It is within the discretion of SHARING PARTNER to provide personnel at the time in which VA had access to the Space. In the event of an emergency, the VA will notify SHARING PARTNER regarding access to the Space as soon as reasonably feasible under the circumstances. Notwithstanding the foregoing in subparagraph b., in no event shall the VA have access to SHARING PARTNER's equipment or utility cabinets, and VA shall exercise its access rights contained in this section in a manner so as not to unduly disrupt or interfere with the operation of the RCF.

## SHARING AGREEMENT V261S-1583

10. SHARING PARTNER'S Property: During the course of occupancy, all documents, records, programs, equipment, materials and other appurtenances placed by SHARING PARTNER and confined within the Space shall remain the sole property of SHARING PARTNER or its designees. Such items will not be subject to access or possession by individuals or organizations other than those authorized by SHARING PARTNER.

11. Radio Transmitter Installations and Operation:

a. SHARING PARTNER shall obtain, to the extent required by law, applicable Federal Communications Commission (FCC) operating license(s). SHARING PARTNER shall, upon request, provide to the VA a copy of such license(s) or a certified copy of the request for such licenses(s) prior to VA allowing operation of radio transmitter facilities.

b. SHARING PARTNER shall cease operation and eliminate any frequency interference to the VA's communications equipment or medical equipment in use at the Medical Center as of the date hereof, and will not permit its equipment or use of the Space as a RCF site to cause interference with or impairment of the medical communications equipment or fibrillators, electrocardiogram equipment, pagers or any other medical equipment used by the VA on, around or in the VA Medical Center. The VA will not enter into any sharing agreement after the date of this Agreement which would interfere with, or otherwise permit any third party to cause any adverse interference with, SHARING PARTNER's use of the RCF at the Space. In the event of any such interference, the CITY shall provide written notification to the VA of the interference. The VA, upon receipt of the notification will provide written and verbal notification to the interfering party, informing them of the interference with City's emergency communication facilities and requesting that they cease such interference immediately. The interfering party shall take all necessary steps to correct and eliminate the interference within a reasonable time (not to exceed 10 days) after receipt of the written VA notification. VA will use its best efforts to cause the elimination of interference within 48 hours, or as soon as possible thereafter, through use of telephone or email, as the SHARING PARTNER's equipment is for emergency purposes. However, as the other Sharing Partner's Sharing Agreements allow 10 days to eliminate interference, VA cannot guarantee or require other Sharing Partners to conform to a 48 hours time limit. If the interfering party does not eliminate the interference, within 10 days, the party shall be directed by the VA to immediately cease the operation of the equipment that is creating the interference. SHARING PARTNER shall receive rent abatement for each day of interference with the RCF, upon written notification by SHARING PARTNER to VA, of the interference.

c. If SHARING PARTNER's RCF should cause interference to VA or other existing sharing partners of VA located at the Medical Center, VA shall notify SHARING PARTNER in writing of such interference, and SHARING PARTNER shall proceed to try to correct such harmful interference. If within ten (10) days from receipt of notice of interference SHARING PARTNER has failed to correct such interference (and such interference is to the VA or a Sharing Partner of VA that located its equipment at the Medical Center before SHARING PARTNER), the VA may require that SHARING PARTNER cease operation of SHARING PARTNER's RCF until such harmful interference can be corrected or eliminated, at which time SHARING PARTNER may resume operation of SHARING PARTNER Facilities. VA shall permit SHARING PARTNER to test SHARING PARTNER Facilities periodically in order to correct such



## SHARING AGREEMENT V261S-1583

harmful interference. In the event of any interference that SHARING PARTNER cannot correct and the VA requires that SHARING PARTNER cease operations as set forth above, then SHARING PARTNER shall have the right to terminate this Agreement effective immediately, without liability for payment of rent during the period between termination and removal of the RCF, provided the SHARING PARTNER has vacated the Space within ninety (90) calendar days after receipt of written notification by VA. Otherwise, SHARING PARTNER will be liable to pay for all rent until Space is finally vacated. Nevertheless, SHARING PARTNER is liable to pay for all electricity used and billed, until the premises are vacated. As of the date of VA directed cessation of SHARING PARTNER RCF operations, VA, without liability, has the right to terminate electrical service to the SHARING PARTNER'S RCF.

d. Notwithstanding the foregoing sections IIB.12 (b) and (c), SHARING PARTNER's obligation to eliminate frequency interference with other sharing partner's communications equipment, shall not apply to other sharing partners' communications equipment installed subsequent to the VA Contracting Officer's signature date of this Agreement, unless the frequency interference is a result of, or caused by SHARING PARTNER's installing new equipment, modifying existing equipment or replacing existing equipment, subsequent to the date that the other sharing partner(s) equipment has been installed. At no time is SHARING PARTNER's equipment allowed to cause interference with or impairment of the following VA owned equipment: office equipment, computer or communications equipment or fibrillators, electrocardiogram equipment, pagers or any other medical equipment used by the VA or any of its Agents. For this Agreement, SHARING PARTNER and other sharing partners are not considered "agents" of the VA or the U. S. Government.

## 12. Site Conditions And Damage:

a. Except as may be otherwise provided, no VA property shall be destroyed, displaced, or damaged by SHARING PARTNER in the exercise of the privilege granted by this Agreement without prior written consent of the Contracting Officer. SHARING PARTNER shall conduct no mining operations nor remove any mineral substances from the premises of the VA, which are herein agreed to be used.

b. Upon termination or expiration of this Agreement, the space shall be restored to its pre-existing condition and configuration, damage by casualty and reasonable wear and tear excepted. The SHARING PARTNER shall be responsible for all damages to VA's property caused by SHARING PARTNER'S removal of its equipment. Any and all repairs will be at the expense of the SHARING PARTNER.

c. SHARING PARTNER has inspected and knows the condition of the Space, and it is understood that the same is hereby used without any representation or warranty by the Government whatsoever except as set forth in this Agreement. The VA has no obligation to make any alterations, repairs, or additions to prepare the Space for SHARING PARTNER's use at the commencement of this Agreement.

d. No alterations shall be made or improvements installed in the Space by the SHARING PARTNER without the prior written consent of the VA.





## SHARING AGREEMENT V261S-1583

e. The right is hereby reserved to the VA, its officers, agents, and employees to enter upon said premises at any time for the purpose of inspection and inventory and when otherwise deemed necessary for the protection of the interests of the Government in accordance with Section II C.10, and SHARING PARTNER shall have no claim of any character on account thereof against the Government or any officer, agent, or employee thereof, except if such entry and activity results in damage to the RCF or its operations due to the acts or negligence of the Government or any officer, agent, or employee.

f. Any use made of the Medical Center, and any construction, maintenance, repair, or other work performed in the Medical Center by SHARING PARTNER, including the installation and removal of any article or thing, shall be accomplished in a manner reasonably satisfactory to VA based upon the terms and provisions of this Agreement.

## D. AGREEMENT RENTAL RATES:

1. The following monthly Use of Space rates shall apply:

<u>Base Period</u>	<u>Year</u>	<u>Period of Term</u>	<u>Monthly Rate</u>
	Year 1:	April 1, 2003 through March 31, 2004	\$3,000
	Year 2:	April 1, 2004 through March 31, 2005	\$3,090
	Year 3:	April 1, 2005 through March 31, 2006	\$3,138
	Year 4:	April 1, 2006 through March 31, 2007	\$3,278
	Year 5:	April 1, 2007 through March 31, 2008	\$3,377
	Year 6:	April 1, 2008 through March 31, 2009	\$3,478
	Year 7:	April 1, 2009 through March 31, 2010	\$3,582
	Year 8:	April 1, 2010 through March 31, 2011	\$3,690
	Year 9:	April 1, 2011 through March 31, 2012	\$3,800
	Year 10:	April 1, 2012 through March 31, 2013	\$3,914
<b>Option 1</b>			
	Year 11:	April 1, 2013 through March 31, 2014	\$ TBD
	Year 12:	April 1, 2014 through March 31, 2015	\$ TBD
	Year 13:	April 1, 2015 through March 31, 2016	\$ TBD
	Year 14:	April 1, 2016 through March 31, 2017	\$ TBD
	Year 15:	April 1, 2017 through March 31, 2018	\$ TBD
<b>Option 2</b>			
	Year 16:	April 1, 2018 through March 31, 2019	\$ TBD
	Year 17:	April 1, 2019 through March 31, 2020	\$ TBD
	Year 18:	April 1, 2020 through March 31, 2021	\$ TBD
	Year 19:	April 1, 2021 through March 31, 2022	\$ TBD
	Year 20:	April 1, 2022 through March 31, 2023	\$ TBD

TBD means "To Be Determined by Subsequent Negotiation"

## SHARING AGREEMENT V261S-1583

2. On the above Year dates (April 1, 20XX) the SHARING PARTNER shall begin paying the indicated monthly rate, in accordance with PAYMENTS Section II E.

3. SHARING PARTNER shall have the right to renew this Agreement two (2) times, each for an additional five year term, by notifying the VA in writing of its intent to renew no later than one hundred and twenty (120) calendar days prior to expiration of the initial Agreement term or any extension thereof; immediately thereafter begin good faith negotiations; and reaching agreement with VA on the rental rates for the option period's years (Option 1: years 11 through 15; Option 2: years 16 through 20). Exercise of a renewal option will necessitate negotiation of "fair market value rent" for the Option period year monthly rents; no other terms or conditions will be altered by such renewal. In determining fair market value monthly rent, the VA and SHARING PARTNER shall include looking at the rental rates for other antenna spaces in the vicinity. Nevertheless, the VA is not limited to basing its determination of a "fair market value" on this criterion only, but can develop or use any criteria deemed by the VA to be relevant. If the VA and SHARING PARTNER are unable to reach agreement, the SA shall be cancelled by Unilateral Modification by the VA, as of the end of that current year period.

## E. PAYMENTS:

1. Monthly Use of Space payments for the base period and any and all options periods, and payment of the utility billing, shall be made by the 10th business day of every month.

2. Payment shall be in the form of a certified or Cashier's check, bank draft, US Post Office money order, SHARING PARTNER bank check, or US currency, in the Payment amount listed above. SHARING PARTNER shall forward these monthly payments to the attention of the "Agent Cashier" at the address identified on the front-page block 4, Section 1 – Agreement Award and Acceptance.

3. If the Agreement commencement date is other than the first calendar day of a calendar month, or if Agreement cancellation is other than the last calendar day of a calendar month, the Agreement rate for that month shall be prorated on a daily basis, based on a thirty (30) day month.

4. Notwithstanding any other provision of this Agreement, unless paid as specified above, all amounts that are due by SHARING PARTNER to the VA under this Agreement shall bear simple interest at the rate established by the Secretary of the Treasury as provided in Section 12 of the Contracts Disputes Act of 1978 (Public Law 95-563), from the date of written VA "Demand letter", until paid.

## F. CANCELLATION:

1. SHARING PARTNER may cancel this Agreement at any time by providing the VA Contracting Officer written notice at least sixty (60) calendar days prior to the cancellation date and SHARING PARTNER will vacate the premises in accordance with Section II paragraph C. subparagraphs 7 and 12.

## SHARING AGREEMENT V261S-1583

2. **PRIORITY USE FOR VETERANS:** The VA reserves the right to deny provision of Space or utility service to SHARING PARTNER if provision of space or utility service to SHARING PARTNER would deny, diminish, or materially delay care to eligible veterans. If requested by SHARING PARTNER, the VA will make a good faith effort to obtain alternative suitable space for SHARING PARTNER's purposes. The VA's good faith effort to find suitable space does not guarantee that suitable space will be available or suitable for SHARING PARTNER's purposes. If such space is unavailable or unsuitable for SHARING PARTNER's purposes, the Agreement shall be cancelled as set forth above. The VA agrees to notify SHARING PARTNER of any changes in availability of space or utility service specified in this Agreement.

3. Written determinations by the VA concerning the availability of Space, or alternative suitable Space and utility service to be provided by the VA pursuant to this Agreement are conclusive and binding on the parties to this Agreement and non-reviewable. The determination of the VA to not provide Space or alternative suitable Space and utility service called for by this Agreement because of its unavailability does not constitute a breach of the Agreement by VA.

4. If as described in subparagraph 2, above, the Space is required for priority use for veteran's needs, the VA may cancel this Agreement at any time, without incurring any liability to SHARING PARTNER by furnishing SHARING PARTNER a written Cancellation Notice immediately upon the VA's reasonable determination that SHARING PARTNER's continued use of the space would deny, diminish, or materially delay care to eligible veterans, but in no event less two hundred and seventy (270) calendar days prior to the cancellation date.

5. SHARING PARTNER is responsible for payment of all rents and services rendered by the VA until SHARING PARTNER ceases operations, provides the VA written notification of cessation of operations, and vacates the premises, unless SHARING PARTNER has vacated the Space within ninety (90) calendar days after cessation of operations, and prior to the cancellation date (270 days). In which case SHARING PARTNER shall be responsible only for electricity usage up to the time of cessation of operations. Otherwise, SHARING PARTNER will be liable to pay for all rent and electricity usage from the date of Cancellation Notification until Space is finally vacated. The VA agrees that it shall not serve a cancellation notice to provide the Space to an unrelated third party. VA reserves the right to occupy the Space, terminate electricity service, and exclude SHARING PARTNER as of the cancellation date.

6. Except as otherwise set forth herein, if this Agreement is cancelled by SHARING PARTNER, SHARING PARTNER will be responsible for payment of all amounts due the VA until such time SHARING PARTNER vacates the Space.

7. Notwithstanding any other term and condition of the Agreement, in the event of mobilization or national emergency which requires the VA to use the Space, the Space shall be vacated by the SHARING PARTNER and returned to the VA control by the sixtieth (60) calendar day following written notification by the Contracting Officer to the SHARING PARTNER. The SHARING PARTNER shall vacate the Space, remove the property of the SHARING PARTNER, and restore the Space as provided for in Section II C. (SITE CONDITIONS AND DAMAGE) 13 b. In the event SHARING PARTY so vacates the premises, SHARING PARTY shall not be responsible for payment of rent but must pay for all electricity used and billed for the period following the VA's termination notice.



## SHARING AGREEMENT V261S-1583

## G. GENERAL TERMS AND CONDITIONS:

## 1. Modifications:

a. The terms described herein may be changed only by written modification to this Agreement. If in agreement with the terms of the requested modification, the Contracting Officer shall prepare the modification to this Agreement. All modifications shall be in writing and, except for cancellation, shall have the written consent of an authorized representative of the SHARING PARTNER and the Contracting Officer or other authorized VA representative. The effective date of any such modification shall be the date of the last signature on the modifications, unless a specific date is stated in the modification.

b. Any oral statement or representation by any representative of the VA, changing or supplementing the Agreement or any condition thereof, is unauthorized and shall confer no obligation upon the VA or right upon SHARING PARTNER. Furthermore, no interpretation of any provision of the Agreement, including applicable performance requirements, shall be binding on the VA unless furnished or agreed to in writing, by the Contracting Officer or authorized VA representative.

c. Any oral statement or representation by any representative of SHARING PARTNER, changing or supplementing the Agreement or any condition thereof, is unauthorized and shall confer no obligation upon the SHARING PARTNER or right upon VA. Furthermore, no interpretation of any provision of the Agreement, including applicable performance requirements, shall be binding on SHARING PARTNER unless furnished or agreed to in writing, by an authorized SHARING PARTNER representative.

## 2. Claims:

a. SHARING PARTNER is a self-insured public entity. The VA may file a claim in accordance with SHARING PARTNER's practices and California law, and otherwise pursue all other available legal remedies hereunder in accordance with applicable law.

b. The VA is a self-insured entity under the Federal Tort Claims Act, 28 U.S.C. Section 1346. SHARING PARTNER may file a claim in accordance with the VA's practices and the Federal Tort Claims Act, and otherwise pursue all other available legal remedies in accordance with the Federal Tort Claims Act and applicable law.

3. Public Liability Insurance: SHARING PARTNER shall obtain and keep in force and effect, public liability insurance coverage in the minimum amount of \$1,000,000 (One Million Dollars) per occurrence to protect the VA from property damage (fire damage included) and bodily injury claims. Evidence of such insurance coverage shall be furnished to the Contracting Officer prior to the SHARING PARTNER taking occupancy of said property. Notwithstanding anything to the contrary above, the VA recognizes and agrees that SHARING PARTNER may self-insure for the above insurance requirements.

## SHARING AGREEMENT V261S-1583

4. Waivers of Subrogation: VA and the SHARING PARTNER hereby waive any right of recovery against the other due to loss of or damage to the property of either the VA or the SHARING PARTNER when such loss or damage to property arises out of the Acts of God.

5. Damage to Property: Any property of the VA destroyed or damaged by SHARING PARTNER incident to SHARING PARTNER'S use and occupation of said property shall be promptly repaired or replaced by SHARING PARTNER to the condition it was in prior to such damage. If SHARING PARTNER is unable or unwilling to so repair the property, then VA may file a claim with SHARING PARTNER and pursue all other available legal remedies in accordance with applicable law. Any property of SHARING PARTNER destroyed or damaged by the VA shall be promptly repaired or replaced by VA to the condition it was in prior to such damage. If the VA is unable or unwilling to so repair the property, then SHARING PARTNER may file a claim with the VA and pursue all other available legal remedies in accordance with the Federal Tort Claims Act and applicable law.

6. Order of Precedence: The terms, conditions of this Agreement, and exhibits included herein, including any formal written modifications, thereto, constitute the complete understanding between the parties and takes precedence over any other language, oral or written. In the event of conflict or disagreement between the Agreement and exhibits, the Agreement takes precedence.

7. Default by SHARING PARTNER:

a. In the event of breach by SHARING PARTNER, before canceling the Agreement the VA will provide SHARING PARTNER with thirty (30) days prior written notice to cure a monetary default and thirty (30) days prior written notice to cure a non-monetary default. If at the end of the thirty-day period SHARING PARTNER fails to cure the monetary default or the non-monetary default as specified herein, the VA will have the right to cancel the Agreement without further notice to SHARING PARTNER provided, however, for any no-monetary default, SHARING PARTNER will not be in default of this Agreement if SHARING PARTNER commences to cure the non-monetary default within the thirty (30) days written notice and thereafter proceeds to cure the default with reasonable diligence.

8. Disputes: All disputes arising or relating to this Agreement shall be resolved in accordance with the following:

a. As used herein, "claim," means a written demand or assertion by one of the parties seeking as a legal right, the payment of money, adjustment or interpretation of Agreement terms, or other relief, arising or relating to this Agreement.

b. Any controversy or claim arising out of or relating to this Agreement on behalf of SHARING PARTNER shall be presented initially to the Contracting Officer for consideration. The VA will furnish a written reply on the claim to SHARING PARTNER.

c. In the event the parties cannot amicably resolve the matter, any controversy or claim arising out of or relating to this Agreement, or breach thereof, shall be settled by



## SHARING AGREEMENT V261S-1583

arbitration at the Department of Veterans Affairs (VA) Board of Contract Appeals in accordance with procedures set forth in the Alternative Means of Dispute Resolution, VA Directive 5978 and Alternative Disputes Resolution Act of 1996, and the Presidential Memorandum of May 1, 1998, and judgment upon any award rendered by the Arbitrator(s) may be entered by any Court having jurisdiction thereof.

d. Any claim by either party must be presented no later than ninety (90) calendar days after cancellation or final expiration of this Agreement, whichever occurs earlier, otherwise such party forfeits its right(s) to relief.

9. **Governing Law:** Notwithstanding any other parts of this Agreement, this Agreement shall be governed, construed, and enforced in accordance with Federal law and California law, however, in the event there is an unavoidable conflict between Federal and California Law, Federal Law will take precedence.

10. **Marketing:** SHARING PARTNER shall not advertise or use any marketing material, logos, trade names, service marks, or other material belonging to the Department of Veterans Affairs or VA without the consent of VA.

11. **VA Representatives:**

a. VA will assign a Contracting Officer or other representative who will be authorized to act on behalf of VA in the following capacity: make changes to the Agreement provisions, including changes involving increases or decreases in Agreement price, and no cost changes, making changes to the scope of the Agreement, requiring extras other than stated in the Agreement, extending the time established in the Agreement, canceling the Agreement in whole or in part, or conducting price or cost negotiations for proposed Agreement changes. A Contracting Officer or other authorized representative is the only official who can bind the VA.

b. The Contracting Officer or other authorized representative reserves the right to designate representatives to act for him/her in furnishing technical guidance and advice, or to generally oversee the technical aspects of the services provided under this Agreement. Such designation will be in writing and will define the scope and limitations of the designee's authority. A copy of the designation will be furnished to SHARING PARTNER upon Agreement award.

12. **Relationship between the Parties:** The relationship of the parties to this Agreement is not and shall not be construed or interpreted to be a partnership, joint venture or agency.

13. **Federal Holidays:** For the purposes of this Agreement, the following federal holidays shall be observed and SHARING PARTNER will not have access to the Contracting Officer or other authorized representative for satisfaction or execution of any term of this Agreement, unless specific arrangements are made with the respective VA representative: New Year's Day, Presidents Day, Martin Luther King's Birthday, Memorial Day, Independence Day, Labor Day, Columbus Day, Veterans Day, Thanksgiving, Christmas.



## SHARING AGREEMENT V261S-1583

14. The persons who have executed this Agreement represent and warrant that they are duly authorized to execute this Agreement in their individual or representative capacity as indicated.

15. Authority: This Agreement is entered into under the authority of Title 38 U.S.C., Section 8153.

16. Notices: Any notice given under this Agreement shall be in writing and given by delivering the notice in person or by commercial courier, or by sending it by first-class mail, certified mail, return receipt requested, or Express Mail, return receipt requested, with postage prepaid, to the addresses set forth in Section 1 above or such other address as either the VA or SHARING PARTNER may designate as its new address for such purpose by notice given to the other in accordance with this Section. Any notice hereunder shall be deemed to have been given and received two (2) days after the date when it is mailed if sent by first-class, certified mail, one day after the date when it is mailed if sent by Express Mail, or upon the date personal delivery is made. For convenience of the parties, copies of notices may also be given by telefacsimile to the telefacsimile number set forth in Section 1 above or such other number as may be provided from time to time; however, neither party may give official or binding notice by facsimile.

17. Non-Liability of Officials, Employees and Agents. Notwithstanding anything to the contrary in this Agreement, no elective or appointive board, commission, member, officer, employee or agent of the VA or of SHARING PARTNER shall be subject to any personal liability in the event of any default or breach of this Agreement or for any obligation under this Agreement.

18. MacBride Principles - Northern Ireland: The City and County of San Francisco urges companies doing business in Northern Ireland to move toward resolving employment inequities and encourages them to abide by the MacBride Principles as expressed in San Francisco Administrative Code Section 12F.1, et seq. The City and County of San Francisco also urges San Francisco companies to do business with corporations that abide by the MacBride Principles. The VA acknowledges that it has read and understands the above statement of the City and County of San Francisco concerning doing business in Northern Ireland.

19. Controller's Certification of Funds: The terms of this Agreement shall be governed by and subject to the budgetary and fiscal provisions of the City's Charter. Notwithstanding anything to the contrary contained in this Lease, there shall be no obligation for the payment or expenditure of money by City under this Agreement unless the Controller of the City and County of San Francisco first certifies, pursuant to Section 3.105 of the City's Charter, that there is a valid appropriation from which the expenditure may be made and that unencumbered funds are available from the appropriation to pay the expenditure. Without limiting the foregoing, if in any fiscal year of City after the fiscal year in which the term of this Agreement commences, sufficient funds for the payment of rent and any other payments required under this Agreement are not appropriated, then City may terminate this Agreement, without penalty, liability or expense of any kind to City, as of the last date on which sufficient funds are appropriated. City shall use its reasonable efforts to give the VA reasonable advance notice of such termination.

## SHARING AGREEMENT V261S-1583

20. Non Discrimination in City Contracts and Benefits Ordinance: In the performance of this Agreement, the VA covenants and agrees not to discriminate on the basis of the fact or perception of a person's race, color, creed, religion, national origin, ancestry, age, sex, sexual orientation, gender identity, domestic partner status, marital status, disability, weight, height or Acquired Immune Deficiency Syndrome or HIV status (AIDS/HIV status) against any employee or, any City employee working with, or applicant for employment with, the VA in any of the VA's operations within the United States, or against any person seeking accommodations, advantages, facilities, privileges, services, or membership in all business, social, or other establishments or organizations operated by the VA. The VA is excepted from the requirements of Chapters 12B and 12C of the City and County of San Francisco Administrative Code for purposes of this Agreement, as evidenced by the Sole Source and Emergency Exception Waiver Request Form approved by the City's HRC.

21. Tropical Hardwood and Virgin Redwood Ban: The City and County of San Francisco urges companies not to import, purchase, obtain or use for any purpose, any tropical hardwood, tropical hardwood product, virgin redwood, or virgin redwood wood products.

22. The date on which this Agreement shall become effective (the "Effective Date") and the date the new rental is applicable shall be April 1, 2003, subject to enactment of City's Board of Supervisor's resolution, in its sole and absolute discretion, approving this Agreement in accordance with all applicable laws, and mutual execution of this Agreement by the parties hereto.

23. Notification of Limitations on Contributions: San Francisco Campaign and Governmental Conduct Code (the "Conduct Code") Section 3.700 et seq., and San Francisco Ethics Commission Regulations 3.710(a)-1 – 3.730-1, prohibit the public officials who approved this contract from receiving (1) gifts, honoraria, emoluments or pecuniary benefits of a value in excess of \$50; (2) any employment for compensation; or (3) any campaign contributions for any elective office for a period of up to six years from individuals and entities who are "public benefit recipients" of the contract. Public benefit recipients of the contract are: (1) the individual, corporation, firm, partnership, association, or other person or entity that is a party to the contract; (2) an individual or entity that has a direct 10% equity, or direct 10% participation, or direct 10% revenue interest in that party at the time the public benefit is awarded; or (3) an individual who is a trustee, director, partner or officer of the contracting party at the time the public benefit is awarded.

The VA understands that any public official who approved this contract may not accept campaign contributions, gifts, or future employment from the VA except as provided under the Conduct Code. The VA agrees to notify any other individuals or entities that may be deemed "public benefit recipients" under the Conduct Code because of this contract. Upon request, the VA agrees to furnish, before this contract is entered into, such information as any public official approving this contract may require in order to ensure such official's compliance with the Conduct Code. Upon request, the City agrees to provide, before this contract is entered into, the VA with a list of public officials who, under the Conduct Code, approved this contract. Failure of any public official who approved this contract to abide by the Conduct Code shall not constitute a breach by either the City or the VA of this contract. Notwithstanding anything to the contrary in this contract, neither party shall have the right to terminate the contract due to any failure by the other party to provide the information described in this paragraph.

SHARING AGREEMENT V261S-1583

NOTWITHSTANDING ANYTHING TO THE CONTRARY CONTAINED IN THIS AGREEMENT, THE VA ACKNOWLEDGES AND AGREES THAT NO OFFICER OR EMPLOYEE OF CITY HAS AUTHORITY TO COMMIT CITY HERETO UNLESS AND UNTIL THE CITY'S BOARD OF SUPERVISORS SHALL HAVE DULY ADOPTED A RESOLUTION APPROVING THIS AGREEMENT AND AUTHORIZING CONSUMMATION OF THE TRANSACTION CONTEMPLATED HEREBY. THEREFORE, ANY OBLIGATIONS OR LIABILITIES OF CITY HEREUNDER ARE CONTINGENT UPON ADOPTION OF SUCH A RESOLUTION, AND THIS AGREEMENT SHALL BE NULL AND VOID UNLESS SUCH A RESOLUTION IS ADOPTED IN ACCORDANCE WITH ALL APPLICABLE LAWS.

The VA and the City have executed this Agreement, in triplicate, as of the date first written above.

VA:

DEPARTMENT OF VETERANS AFFAIRS

By: Terrence W Nelson

Its: TERRENCE W. NELSON

CITY: **VA Contracting Officer**

CITY AND COUNTY OF SAN FRANCISCO,  
a municipal corporation

Steve Legnits  
Deputy Director of Property

RECOMMENDED:

Daniela Sullivan  
Acting Executive Director  
Emergency Communications Department

APPROVED AS TO FORM:  
DENNIS J. HERRERA, City Attorney

By: DJH  
Deputy City Attorney

Initial SP



# VAMC/Fort Miley Water Tank Site Plan

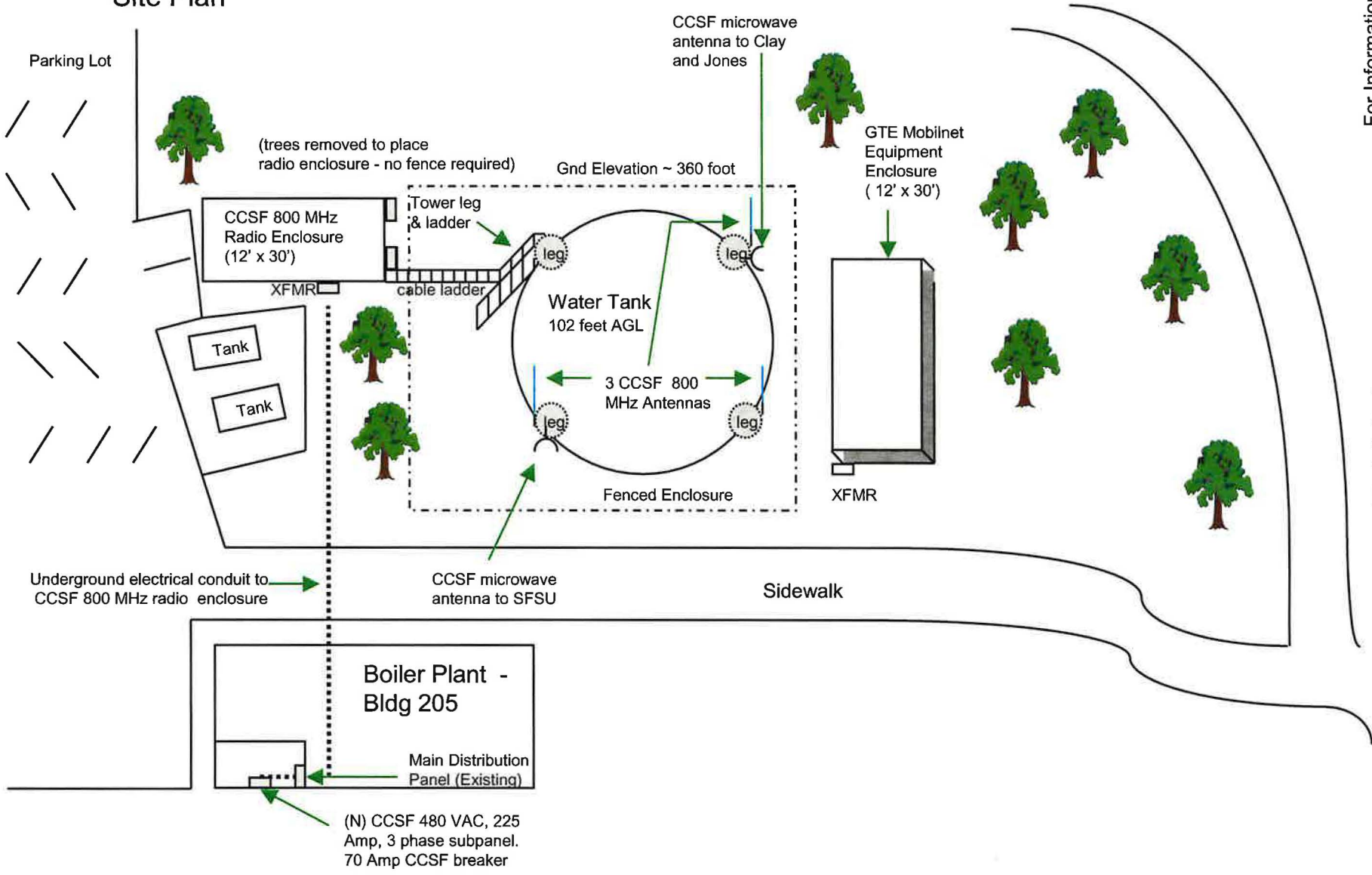

For Information Only  
Not to scale

Exhibit A

VAMC

*Handwritten signature*



VAMC / Fort Miley Water Tank  
CCSF Antenna Site

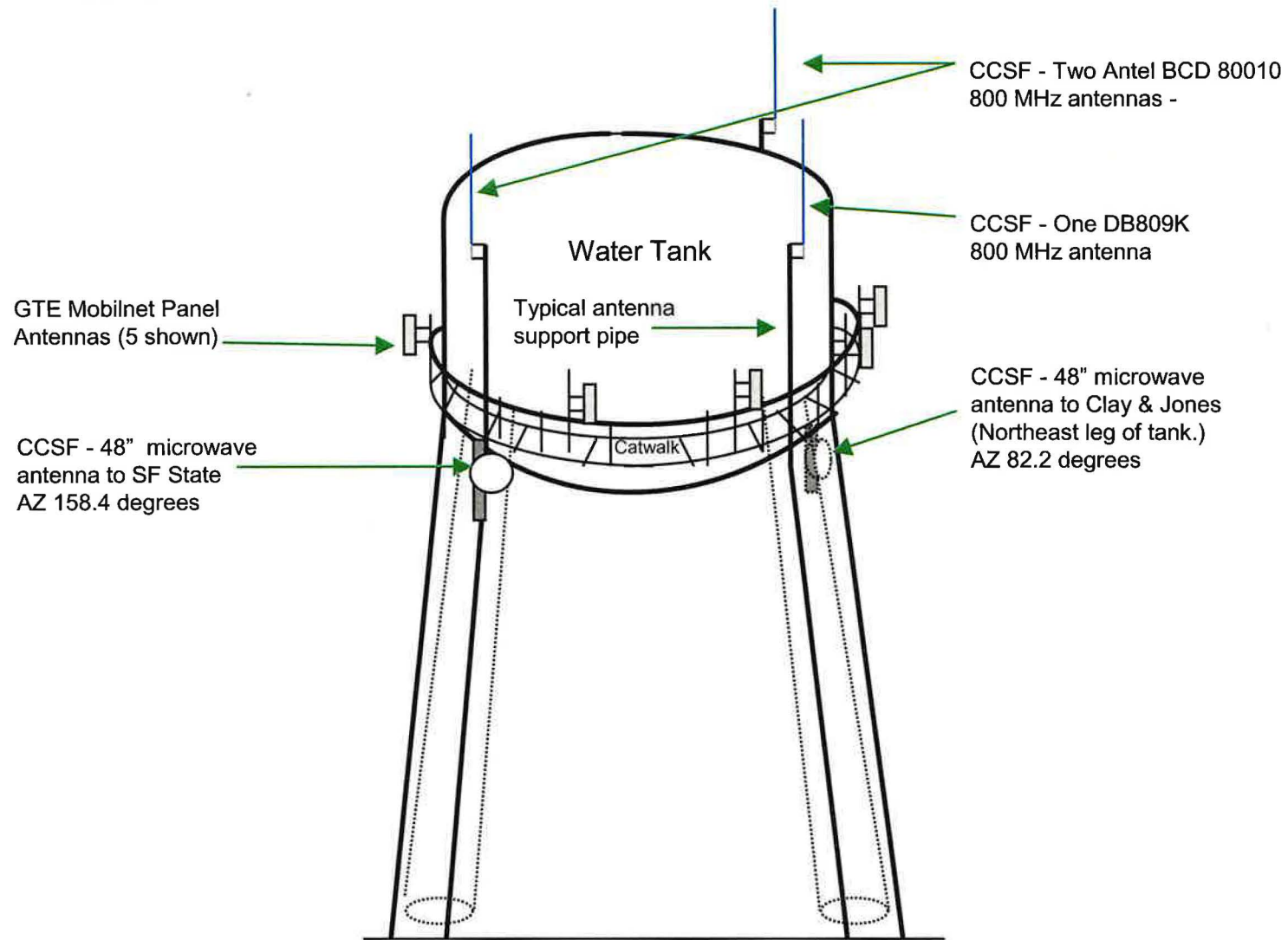

South Elevation

For Information Only  
Not to scale

Exhibit B

VAMC

1 [Real Property License Agreement]

2

, retroactive to April 1, 2003,

8/20/03

3 Resolution authorizing a City-wide 800 MHz Radio System license agreement at the VA  
4 Medical Center, 4150 Clement Street, San Francisco for the Emergency  
5 Communications Department.

6

7

WHEREAS, One of the Emergency Communications Department's ("ECD") eight  
8 City-wide 800 MHz Radio System facilities is located on the grounds of the Department of  
9 Veterans Affairs (the "VA") Medical Center; and

10

11

12

13

WHEREAS, The five-year term of the current license agreement between the City  
and County of San Francisco (the "City") and the VA for the aforementioned City-wide 800  
MHz Radio System facility expired on March 31, 2003 and has continued on a month-to-  
month basis; and

14

15

WHEREAS, ECD desires to continue its operation of this facility at the VA Medical  
Center; and

16

17

18

19

WHEREAS, The City and the VA have negotiated a license agreement for a term of  
ten (10) years commencing on April 1, 2003, with two (2) five-year options to extend the  
term, a copy of which is on file with the Clerk of the Board in File No. 031332 (the  
"License Agreement"); and

20

21

22

23

24

25

WHEREAS, The VA requires in the License Agreement that any disputes be first  
submitted to the VA Contracting Officer. In the event the parties cannot amicably resolve  
the matter, any claim arising out of or related to the License Agreement must be settled by  
arbitration at the Department of Veterans Affairs Board of Contract Appeals in accordance  
with procedures set forth in the Alternative Means of Dispute Resolution, VA Directive 5978  
and Alternative Disputes Resolution Act of 1996, and the Presidential Memorandum of May

1 1, 1998. In addition, the City has the right to pursue all other available legal remedies in  
2 accordance with the Federal Tort Claims Act and applicable law; and

3 WHEREAS, The License Agreement shall be governed, construed, and enforced in  
4 accordance with Federal law and California law, however, in the event there is a conflict  
5 between Federal and California law, Federal law will prevail; and

6 WHEREAS, On June 26, 1997, in Case No. 97.382R, the Department of City  
7 Planning adopted and issued a General Plan Consistency Finding, a copy of which is on  
8 file with the Clerk of the Board in File No. 172-97-53, wherein the Department of City  
9 Planning found that the proposed use of the property under the License Agreement is  
10 consistent with the City's General Plan and with the Eight Priority Policies under Planning  
11 Code Section 101.1 and is categorically exempt from environmental review under CEQA;  
12 now, therefore, be it

13 RESOLVED, That in accordance with the recommendations of the Acting Executive  
14 Director of ECD and the Director of Property, the Director of Property is hereby authorized  
15 on behalf of the City and County of San Francisco to enter into the License Agreement,  
16 with an initial term of ten (10) years commencing on April 1, 2003 and two extension  
17 options of five (5) years each, exercisable by the Director of Property, with the Department  
18 of Veterans Affairs, for the premises housing the City-wide 800 MHz Radio System facility  
19 located at the VA Medical Center, 4150 Clement Street, San Francisco, California, for ECD.  
20 The monthly rent shall be \$3,000 during Year 1 and shall escalate three percent (3%) each  
21 successive year of the initial term. The monthly rent during any extension term shall be the  
22 fair market value at that time, as negotiated and agreed to by the parties at that time. The  
23 City shall continue to pay for the cost of electricity; and, be it

24 FURTHER RESOLVED, That any action taken by any City employee or official with  
25 respect to the License Agreement is hereby ratified and affirmed; and, be it

1           FURTHER RESOLVED, That the Director of Property shall be authorized to enter into  
2 any additional amendments or modifications to the License Agreement, including without  
3 limitation, exhibits or improvement specifications, that the Director of Property determines, in  
4 consultation with the City Attorney, are in the best interest of the City, do not increase the rent  
5 or otherwise materially increase the obligations or liabilities of the City, are necessary or  
6 advisable to effectuate the purposes and intent of the License Agreement as amended or this  
7 resolution, and are in compliance with all applicable laws, including City's Charter.  
8

9 RECOMMENDED:

\$36,000.00 Available from  
Appropriation No.  
03011 770018

11   
12 \_\_\_\_\_  
13 Acting Executive Director  
Emergency Communications Department

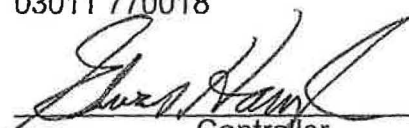
  
\_\_\_\_\_  
Controller

14   
15 \_\_\_\_\_  
Director of Property





# City and County of San Francisco

City Hall  
1 Dr. Carlton B. Goodlett Place  
San Francisco, CA 94102-4689

## Tails

### Resolution

---

**File Number:** 031332

**Date Passed:**

Resolution authorizing, retroactive to April 1, 2003, a City-wide 800 MHz Radio System license agreement at the VA Medical Center, 4150 Clement Street, San Francisco for the Emergency Communications Department.

---

August 26, 2003 Board of Supervisors — ADOPTED

Ayes: 9 - Ammiano, Gonzalez, Hall, Ma, Maxwell, McGoldrick, Newsom, Peskin,  
Sandoval

Excused: 2 - Daly, Dufty

A handwritten checkmark in the bottom right corner of the page.



File No. 031332

I hereby certify that the foregoing Resolution was ADOPTED on August 26, 2003 by the Board of Supervisors of the City and County of San Francisco.

SEP 05 2003

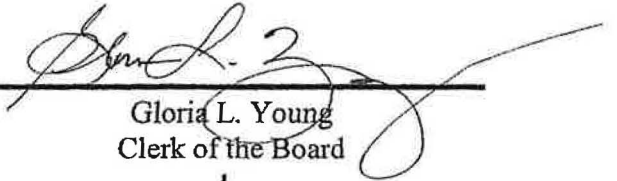
  
\_\_\_\_\_  
Gloria L. Young  
Clerk of the Board

\_\_\_\_\_  
Date Approved

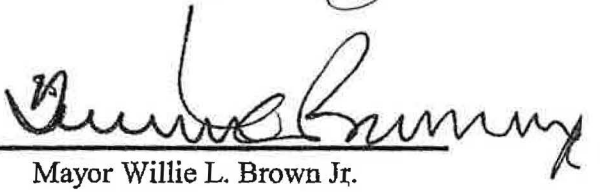
  
\_\_\_\_\_  
Mayor Willie L. Brown Jr.

