

INDUSTRIAL LEASE

Between

**W.Y.L. Orion Properties, LLC, a California limited liability corporation
as Landlord**

and

**CITY AND COUNTY OF SAN FRANCISCO,
as Tenant**

For the lease of

**125 Bayshore Boulevard,
San Francisco, California**

February 12, 2018

TABLE OF CONTENTS

	<u>Page</u>
1. BASIC LEASE INFORMATION	1
2. PREMISES	4
2.1 Lease Premises	4
2.2 Property	4
2.3 Disability Access	4
3. TERM	4
3.1 Term of Lease	4
3.2 Commencement Date and Expiration Date.....	5
3.3 Delay in Delivery of Possession with Improvements Complete	5
3.4 Extension Right.....	5
3.5 Conditions Precedent to Effectiveness of Lease	5
3.6 City's Termination Rights.....	6
4. RENT	6
4.1 Base Rent	6
4.2 Intentionally Deleted.....	7
4.3 Additional Charges	7
5. USE.....	7
5.1 Permitted Use.....	7
5.2 Intentionally Deleted.....	7
5.3 Interference with Access or Use	7
6. LEASEHOLD IMPROVEMENTS	8
6.1 Landlord's Obligation to Construct Improvements	8
6.2 Installation of Telecommunications and Other Equipment	15
6.3 Construction of Improvements that Disturb or Remove Exterior Paint	15
7. ALTERATIONS	16
7.1 Alterations by City	16
7.2 Title to Improvements	17
7.3 City's Personal Property	17
7.4 Alteration by Landlord.....	18
8. REPAIRS AND MAINTENANCE	18
8.1 Landlord's Repairs.....	18
8.2 City's Repairs.....	18

8.3	Liens	19
9.	UTILITIES AND SERVICES	20
9.1	Utilities and Services	20
9.2	Additional Services	20
10.	COMPLIANCE WITH LAWS; PREMISES CONDITION	20
10.1	Premises Condition and Landlord's Compliance with Laws; Indemnity	20
10.2	City's Compliance with Laws; Indemnity	22
10.3	City's Compliance with Insurance Requirements.....	22
11.	SUBORDINATION	22
12.	DAMAGE AND DESTRUCTION.....	23
12.1	Minor Damage	23
12.2	Major Damage	24
13.	EMINENT DOMAIN	24
13.1	Definitions.....	24
13.2	General	24
13.3	Total Taking; Automatic Termination	25
13.4	Partial Taking; Election to Terminate.....	25
13.5	Termination of Lease; Rent and Award.....	25
13.6	Partial Taking; Continuation of Lease	25
13.7	Temporary Taking	26
14.	ASSIGNMENT AND SUBLETTING	26
15.	DEFAULT; REMEDIES	26
15.1	Events of Default by City	26
15.2	Landlord's Remedies	26
15.3	Landlord's Default.....	27
16.	INDEMNITIES.....	28
16.1	City's Indemnity	28
16.2	Landlord's Indemnity.....	28
16.3	City's Self-Insurance	29
16.4	Landlord's Insurance	29
16.5	Waiver of Subrogation.....	29
17.	ACCESS BY LANDLORD	29
18.	ESTOPPEL CERTIFICATES	30
19.	SURRENDER OF PREMISES	30

20.	HAZARDOUS MATERIALS	30
20.1	Definitions.....	30
20.2	Landlord's Representations and Covenants	31
20.3	Landlord's Covenants	31
20.4	Landlord's Environmental Indemnity.....	32
20.5	City's Covenants.....	32
20.6	City's Environmental Indemnity.....	33
21.	SPECIAL PROVISIONS.....	33
21.1	Extension Right.....	33
21.2	Intentionally Deleted.....	34
22.	GENERAL PROVISIONS	34
22.1	Notices	34
22.2	No Implied Waiver	35
22.3	Amendments	35
22.4	Authority	35
22.5	Parties and Their Agents; Approvals	35
22.6	Interpretation of Lease	36
22.7	Successors and Assigns.....	36
22.8	Brokers.....	36
22.9	Severability	36
22.10	Governing Law	37
22.11	Entire Agreement.....	37
22.12	Attorneys' Fees	37
22.13	Holding Over	37
22.14	Cumulative Remedies	38
22.15	Time of Essence.....	38
22.16	Survival of Indemnities.....	38
22.17	Signs.....	38
22.18	Quiet Enjoyment and Title.....	38
22.19	Bankruptcy.....	39
22.20	Transfer of Landlord's Interest	39
22.21	Non-Liability of City Officials, Employees and Agents	39
22.22	MacBride Principles - Northern Ireland	39
22.23	Controller's Certification of Funds.....	40

22.24	Prevailing Wages for Construction Work.....	40
22.25	Non Discrimination in City Contracts and Benefits Ordinance.....	40
22.26	Tropical Hardwood and Virgin Redwood Ban	42
22.27	Bicycle Parking Facilities	42
22.28	Resource-Efficient City Buildings and Pilot Projects.....	42
22.29	Counterparts.....	42
22.30	Effective Date; Conditions Precedent to Effectiveness of Lease.....	42
22.31	Sunshine Ordinance	43
22.32	Conflicts of Interest.....	43
22.33	Notification of Limitations on Contributions	43
22.34	Preservative-Treated Wood Containing Arsenic	44
22.35	Cooperative Drafting	44

LIST OF EXHIBITS AND SCHEDULES

- EXHIBIT A – Site Plans of Premises and Exclusive Use Outdoor Area
- EXHIBIT B – Notice of Commencement Date, Rent Commencement Date and Expiration Date
- EXHIBIT C-1 – Landlord’s Disclosure of Hazardous Materials Reports and Information
- EXHIBIT C-2 – Tenant’s Listing of Hazardous Materials
- EXHIBIT D – Intentionally Deleted
- EXHIBIT E – Leasehold Improvements
- EXHIBIT F – Form of Landlord Consent and Waiver Agreement
- EXHIBIT G – Form of Estoppel Certificate

INDUSTRIAL LEASE

THIS INDUSTRIAL LEASE (this "Lease"), dated for reference purposes only as of February 12, 2018, is by and between W.Y.L. Orion Properties, LLC, a California limited liability corporation ("Landlord"), and the CITY AND COUNTY OF SAN FRANCISCO, a municipal corporation ("City" or "Tenant").

Landlord and City hereby agree as follows:

1. BASIC LEASE INFORMATION

The following is a summary of basic lease information (the "Basic Lease Information"). Each item below shall be deemed to incorporate all of the terms in this Lease pertaining to such item. In the event of any conflict between the information in this Section and any more specific provision of this Lease, the more specific provision shall control.

Lease Reference Date:	February 12, 2018
Landlord:	W.Y.L. Orion Properties, LLC
Tenant:	CITY AND COUNTY OF SAN FRANCISCO
Buildings:	The buildings on the property commonly known as 125 Bayshore Boulevard, San Francisco, California, Assessor's Parcel Number Block 5559, Lots 002 and 019.
Property (<u>Section 2.2</u>):	The Buildings, the parcel of land upon which the Buildings are located that total approximately 31,200 square feet of land, and all other improvements on or appurtenances to such land.
Premises (<u>Section 2.1</u>):	The Buildings, comprised of approximately 12,965 rentable square feet of warehouse space and 10,000 square feet of office space, as more particularly described and shown on <u>Exhibit A</u> attached hereto.
Term (<u>Section 3</u>):	Six (6) months plus any partial month following the Commencement Date, commencing on the Commencement Date (as defined in Section 3.1) and ending on the Expiration Date, subject to City's Extension Options, as set forth in Section 3.4 and Section 21.1.
Estimated Commencement Date:	The "Estimated Commencement Date" shall be April 1, 2018.

Commencement Date:	The Commencement Date shall be the date this Lease is fully executed by Landlord and City, following satisfaction of all conditions precedent to effectiveness, as set forth in Sections 3.5 and 22.30 below.
Expiration Date:	The "Expiration Date" shall mean the last day of the sixth (6 th) full month following the Commencement Date, subject to City's option to extend pursuant to Section 3.4.
Extension Options (Section 3.4):	City shall have the option to extend the Term for five (5) successive additional periods of one (1) year each (the "Extension Terms"), as set forth in Section 3.4 and Section 21.1.
Base Rent (Section 4.1):	Annual Base Rent: \$489,000 Monthly payments: \$40,750
Rent Commencement Date (Section 4.1):	The Rent Commencement Date shall be March 1 st 2018, or Landlord's satisfaction of the requirements set forth in Section 3.5, whichever occurs later.
Adjustment Dates (Section 4.2):	There shall be no adjustment to Rent during the initial term.
Base Rent for Extension Term (Section 21.1(c)):	Base Rent shall be adjusted if City exercises an Extension Option, as provided in Section 3.4 and Section 21.1.
Permitted Uses (Section 5.1):	"Permitted Uses" shall be: Navigation Center, public programs, general office and any other purpose consistent with existing zoning. A "Navigation Center" is a facility that is used to facilitate an exit from homelessness to more traditional housing and to offer support services as required.
Delivery Condition (Sections 3.3 and 6):	Landlord shall deliver the Premises in the condition described in Section 3.3.
Leasehold Improvements; Allowance (Article 6):	Landlord shall perform the Leasehold Improvements pursuant to Article 6 below. There shall be no allowance from Landlord.
Utilities and Services (Section 9.1):	"Industrial gross lease" under which City is responsible for services and utilities to the

Premises, and performs certain repairs and maintenance as provided in Section 8.2 and Section 9.1. City and shall pay for its direct and separately metered utilities. City, at City's expense, shall be responsible for its direct services to the Premises, including janitorial, refuse removal, pest control, and, at City's election, security.

Notice Address of Landlord (Section 23.1):

c/o James Lew
595 Newhall Ave
San Francisco, CA 94124

With a copy to:

Santino DeRose
466 Green Street, Suite #203
San Francisco, CA 94133

Landlord Contact Telephone Number:

(415) 559-2246

Alternate Contact for Landlord:

Luke Wong

Alternate Landlord Contact Telephone Number:

(415) 676-8558

Notice Address for City (Section 23.1):

Real Estate Division
City and County of San Francisco
25 Van Ness Avenue, Suite 400
San Francisco, California 94102
Attn: John Updike
Director of Real Estate
Re: Navigation Center Lease
Fax No.: (415) 552-9216

with a copy to:

Department of Homelessness and Supportive
Housing
City and County of San Francisco
1650 Mission Street
San Francisco, California 94112
Attn: Nina Marinkovich
Fax No.: (415) 557-6033

and to:

Office of the City Attorney
City Hall, Room 234
1 Dr. Carlton B. Goodlett Place
San Francisco, CA 94102-4682
Attn: Real Estate/Finance Team
Re: Navigation Center
Fax No.: (415) 554-4755

Key Contact for City:

Jeff Suess

City Contact Telephone No.:

415-554-9873

Alternate Contact for City:

Marta Bayol

Alternate Contact Telephone No.:

415-554-9865

Broker:

DeRose & Appelbaum, Inc., as exclusive
representative of Landlord

2. PREMISES

2.1 Lease Premises

In consideration of the obligation of City to pay Rent as herein provided and in consideration of the other terms, covenants, and conditions hereof, Landlord leases to City and City leases from Landlord, subject to the provisions of this Lease, the Property and those premises identified in the Basic Lease Information, which includes all of the Buildings and of the real property described and shown on the attached Exhibit A (the "Premises").

2.2 Property

The Buildings, land upon which the Buildings are located and all other improvements on or appurtenances to such land are referred to collectively as the "Property."

2.3 Disability Access

California Civil Code Section 1938 requires commercial landlords to disclose to tenants whether the property being leased has undergone inspection by a Certified Access Specialist ("CASp") to determine whether the property meets all applicable construction-related accessibility requirements. City is hereby advised that the Premises have not been inspected by a CASp.

3. TERM

3.1 Term of Lease

The Premises are leased for an initial term (the "Initial Term") commencing on the date specified in the Basic Lease Information as the estimated commencement date (the "Estimated Commencement Date"), or such later date as the Conditions Precedent described in Section 3.5 below have been satisfied (the "Commencement Date"). The Initial Term of this Lease shall end

on the Expiration Date specified in the Basic Lease Information, or such earlier date on which this Lease terminates pursuant to the provisions of this Lease, provided that City shall have the right to extend the Initial Term pursuant to Section 3.4 (Extension Right), below. The word "Term" as used herein shall refer to the Initial Term and any Extended Term(s) if City exercises the Extension Option.

3.2 Commencement Date and Expiration Date

The dates on which the Term commences (pursuant to Section 3.1 above) and terminates pursuant hereto are referred to respectively as the "Commencement Date" and the "Expiration Date." If the Commencement Date occurs on a date other than the Estimated Commencement Date, then promptly thereafter Landlord shall deliver to City a notice substantially in the form of Exhibit B attached hereto, confirming the actual Commencement Date, but Landlord's failure to do so shall not affect the commencement of the Term.

3.3 Delay in Delivery of Possession with Improvements Complete; City Termination Right

Landlord shall deliver possession of the Premises to City with all of the Leasehold Improvements substantially completed and accepted by City's Director of Property pursuant to Article 6 and Exhibit E. Landlord shall use its best efforts to deliver possession of the Premises with all of the Leasehold Improvements substantially completed and accepted by City's Director of Property pursuant to Article 6 and Exhibit E on or before August 15, 2018. If Landlord is unable to effect completion of the Leasehold Improvements as provided above by April 1, 2018, regardless, the Commencement Date shall remain April 1, 2018. Notwithstanding the foregoing, if Landlord is unable to deliver possession of the Premises to City in the condition required hereunder on or before the Expiration Date, then City may, at its option, terminate this Lease, without any further liability under this Lease, upon written notice to Landlord, as provided in Section 3.6 below.

3.4 Extension Right

City shall have the right to extend the Initial Term of this Lease (the "Extension Option") for the Extension Terms. Such extension right shall be on all of the terms and conditions contained Section 21.1 of this Lease. The word "Term" as used herein shall refer to the Initial Term and any Extension Term(s) if City exercises the Extension Option.

3.5 Conditions Precedent to Effectiveness of Lease

The following are condition precedent to the effectiveness of the Lease and any of City's obligations hereunder (collectively, "Conditions Precedent"): (i) The City's Mayor and the Board of Supervisors, in the respective sole discretion of each, shall have enacted a resolution approving, adopting, and authorizing this Lease, (ii) delivery to City of Landlord's lender's SNDA form reasonably acceptable to City executed by any existing lender, and (iii) City's approval of Landlord as a qualified City vendor as provided in Section 4.1 below.

The Conditions Precedent are solely for the benefit of City. The Conditions Precedent may not be waived. If the Conditions Precedent have not been satisfied on or before April 1, 2018, then City shall have the right to terminate this Lease pursuant to Section 3.6 below.

Notwithstanding the foregoing, at City's option, City may extend the time period for satisfaction of any Condition Precedent for a reasonable period of time specified by City, to allow such Conditions Precedent to be satisfied, subject to City's further right to terminate this Lease upon the expiration of the period of any such extension if all such Conditions Precedent have not been satisfied.

3.6 City's Termination Rights

City, at its sole option, may terminate this Lease by providing written notice to Landlord, upon the occurrence of any of the following events:

- (a) If Landlord fails to apply for all necessary permits, conditional use permits, approvals and/or licenses required to construct the Leasehold Improvements (as described in Section 6.2) by **May 1, 2018**;
- (b) If Landlord fails to commence construction of the Leasehold Improvement Work (pursuant to Section 6.1 and Exhibit E attached hereto) by **June 1, 2018**, and to continue to diligently pursue such work to completion;
- (c) If Landlord fails to deliver possession of the Premises to City as required under Section 3.3 above, with all work substantially completed and accepted by City's Director of Property pursuant to Section 6 below, on or before **August 15, 2018**; and
- (d) Failure of any Condition Precedent to be satisfied or waived, in accordance with the applicable time periods, terms and conditions set forth in Section 3.5 above.

Landlord will have ten (10) days after the date of receipt of the termination notice to cure the failure of the applicable Condition Precedent. If Landlord cures the failure within the 10-day period, then City's termination notice will be deemed rescinded. If Landlord does not cure the failure, then City's notice of termination shall be effective as of expiration of the 10-day cure period. If solely because of circumstances not within the reasonable control of Landlord more than ten (10) days are reasonably required for such cure, immediately upon receiving City's termination notice, Landlord may notify City of those circumstances. If City agrees that such circumstances are not reasonably in Landlord's control, City will rescind the notice of termination only for so long as Landlord diligently prosecutes such cure to completion. Upon any such termination, City shall reimburse Landlord for all of Landlord's actual costs incurred in the construction of the Leasehold Improvements incurred as of the date of the City's termination. Such request must be made in writing and include sufficient documentation to support any such claim of actual costs incurred. Upon City's termination and City's reimbursement to Landlord of such costs, Landlord shall have no further rights or obligations to each other with respect to the Lease, except for any obligations which specifically survive the termination of this Lease.

4. RENT

4.1 Base Rent

Prior to the Commencement Date, Landlord shall deliver the materials and information required by City's Office of the Controller to establish Vendor Identification Number and set up electronic payments of Base Rent through Paymode-X, a Bank of America Merrill Lynch

business-to-business electronic system. Beginning on the Rent Commencement Date (as defined in the Basic Lease Information), City shall pay to Landlord during the Term the annual Base Rent specified in the Basic Lease Information (the "Base Rent"). The Base Rent shall be payable in equal consecutive monthly payments on or before the first day of each month commencing on the Rent Commencement Date, in advance, to the bank account designated by Landlord pursuant to this Section. City shall pay the Base Rent without any prior demand and without any deductions or setoff except as otherwise provided in this Lease. If the Rent Commencement Date occurs on a day other than the first day of a calendar month or the Expiration Date occurs on a day other than the last day of a calendar month, then the monthly payment of the Base Rent for such fractional month shall be prorated based on a thirty (30)-day month.

4.2 Intentionally Deleted

4.3 Additional Charges

City shall pay to Landlord all charges or other amounts required to be paid or reimbursed by City under this Lease ("Additional Charges"). All such Additional Charges shall be additional rent hereunder and, to the extent payable to Landlord, shall be paid either at the place where the Base Rent is payable or at the address specified for Landlord in the Basic Lease Information, or such other place as Landlord may designate in writing upon not less than thirty (30) days' advance notice. Landlord shall have the same remedies for a default in the payment of any Additional Charges as for a default in the payment of Base Rent. The Base Rent and Additional Charges, including City's Contribution (as defined in Section 6.1(i)), are sometimes collectively referred to below as "Rent."

5. USE

5.1 Permitted Use

City may use the Premises for the Permitted Uses specified in the Basic Lease Information, and for no other use without the prior written consent of Landlord, which shall not be unreasonably withheld or delayed.

5.2 Intentionally Deleted

5.3 Interference with Access or Use

Landlord shall provide to City access to the Buildings and the Premises twenty-four (24) hours per day, seven (7) days per week, together with uninterrupted access thereto to the maximum extent possible, including, without limitation, during any power outages affecting the Premises or any portion of the Buildings; provided, however, that Landlord may, after consultation with the City's Director of Property, interrupt City's access to the Premises or the Buildings in the event of an immediate threat of the Premises, or any other portion of the Buildings being rendered unsafe for human occupancy. If City's use of any of the Premises or access thereto is interrupted as a result of the Landlord's failure to comply with its obligations under this Lease, or any other portion of the Buildings being rendered unsafe for human occupancy due to Landlord's failure to comply with its obligations under this Lease or for any other reason other than City's default hereunder, then Landlord shall immediately undertake all necessary steps to correct such condition. In the event such condition continues for three (3)

consecutive business days and substantially impairs City's ability to carry on its business in the Premises, the Rent payable hereunder shall be abated based on the extent to which such default interferes with City's ability to carry on its business at the Premises. If any such default by Landlord shall continue for sixty (60) days or more after City's use is interrupted and impairs City's ability to carry on its business in the Premises, then City shall have the right, without limiting any of its other rights under this Lease to terminate this Lease, unless Landlord supplies City with evidence reasonably satisfactory to City that either Landlord has complied with its obligations under the Lease or that City's normal and safe use will be restored within ninety (90) days of the date City's use was interrupted, and such use is actually restored within such 90-day period. Nothing in this Section shall limit City's rights with respect to any disruption due to casualty pursuant to Section 12 (Damage and Destruction) hereof.

6. LEASEHOLD IMPROVEMENTS

6.1 Landlord's Obligation to Construct Improvements

Landlord shall provide, at City's cost, turn-key tenant improvements pursuant to mutually agreeable construction plans (as defined in this Section below) and specifications prepared by Landlord's architect, in consultation with City and Exhibit E. Such improvements shall be delivered through Landlord's general contractor approved by City, in accordance with the provisions of this Section. Such work and installations are referred to as the "Leasehold Improvement Work" and "Leasehold Improvements." The architect selected by Landlord and approved by City to prepare the drawings to be prepared by Landlord hereunder is referred to herein as the "Architect." City acknowledges that any architect from the Building Design and Construction division of the San Francisco Public Works is an approved Architect. The general contractor selected by Landlord and approved by City, in its reasonable discretion, to perform the work described herein is referred to herein as the "Contractor." The City shall not unreasonably withhold, delay or condition its consent to Landlord's selection of the Contractor and the Architect.

(a) Plans and Specifications

Within five (5) date of the Effective Date of this Lease (as defined in Section 22.30 hereof), City shall deliver to Landlord 50% design bridging documentation, including a space plan, based on City's program requirements for use of the Premises (the "Bridging Documents"), for the Leasehold Improvements .

Within ten (10) days after the Effective Date and Landlord receiving the Bridging Documents, Landlord shall cause its Architect to commence construction drawings and specifications for the Leasehold Improvements consistent with the Bridging Documents, setting forth in detail all aspects of the design, function and construction of the Leasehold Improvements, in form sufficient for bidding of all elements of construction and to obtain all required permits.

Landlord shall submit the drawings to City for review at approximately 30% completion, 60% completion and 100% completion, and such submittals shall indicate any changes to the space plan or material changes to the specifications called out the in the Bridging Documents. City shall approve or reasonably disapprove the drawings with five (5) working days of City's receipt.

Landlord shall provide City with a list, to be approved by City, of all finishes, flooring, ceiling, walls, paint and coverings, and casework to be installed.

When such drawings are at the level of detail that Landlord's Contractor can (1) provide a good faith Rough Order of Magnitude (ROM) construction budget, and (2) clearly spell out the intended construction including an architectural plan, power and signal plan, ceiling plan, flooring plans, mechanical and electrical specifications for the Leasehold Improvements, designed to achieve LEED ID+C Gold certification and City's obligations to cause the Leasehold Improvements to comply with the requirements of Sections 700 through 713 of the San Francisco Environment Code (the "Pricing Plans"), Landlord shall cause Landlord's Contractor to prepare a ROM Construction budget and Landlord's project manager shall prepare and submit to City all-inclusive Pricing Plans for the ROM Construction budget, including all costs and a 5% contingency for City's approval (the "Initial ROM Budget"). City shall have fifteen (15) days to review and either approve of the Pricing Plans and Initial ROM Budget or provide Landlord with City's adjustments to the Pricing Plans and Initial ROM Budget. Notwithstanding the foregoing, if the Initial ROM Budget exceeds \$2,300,000 (the "Maximum Leasehold Improvement Cost"), all parties shall work in good faith to value engineer the Pricing Plans to reduce such work and budget below Maximum Leasehold Improvement Cost.

Immediately following City's approval of the Pricing Plans and the Initial ROM Budget with any adjustments authorized by City, Landlord, with City's input, shall cause final plans, specifications and working drawings for the Leasehold Improvements to be prepared, in conformity with the requirements hereof (the "Final Working Drawings"). Based on such Final Working Drawings, Landlord shall also prepare an Updated ROM construction budget for City's approval. Such Final Working Drawings and updated ROM construction budget shall be subject to City's prior written approval, which approval shall not be unreasonably withheld, conditioned or delayed, provided however, the updated ROM construction budget based on the Final Working Drawings shall not exceed the Maximum Leasehold Improvement Cost. If City disapproves such Final Working Drawings and specifications, or any portion thereof, then City shall promptly notify Landlord thereof and of the revisions that City reasonably requires in order to obtain City's approval.

Based on the Final Working Drawings, Landlord shall cause its Architect to promptly prepare and submit to City for approval final construction drawings and specifications suitable for permitting and constructing the Leasehold Improvements ("Construction Documents"), based upon and consistent with the approved Final Working Drawings, in accordance with the provisions of this Article 6.

Landlord shall provide at least bi-weekly progress reports regarding the construction drawings, and Landlord and City shall cooperate in good faith in connection with the review and completion of the construction drawings and specifications required to expeditiously finalize the Construction Documents.

(b) HVAC Improvements

The parties hereby agrees to include in the Leasehold Improvements any and all HVAC improvements necessary to the Buildings' HVAC systems so that the HVAC can be maintained in accordance with the requirements of Title 8 California Code of Regulations, Chapter 4. Division of Industrial Safety, Subchapter 7. General Industry Safety Orders, Group 16. Control

of Hazardous Substances, Article 107. Dusts, Fumes, Mists, Vapors and Gases Section 5142, Mechanically Driven Heating, Ventilating and Air Conditioning (HVAC) Systems to Provide Minimum Building Ventilation. Such HVAC improvements shall be designed by a licensed mechanical engineer and shall be subject to City's prior written review and approval which shall not be unreasonably withheld, conditioned or delayed.

Notwithstanding the foregoing, Landlord acknowledges, agrees and warrants that Landlord has no knowledge of any pre-existing Hazardous Materials condition related to the Premises (including without limitation, repairs or replacement of HVAC improvements) or of any facts leading it to believe that the Buildings do not meet any and all applicable indoor air quality standards, including OSHA standards. Accordingly Landlord will be responsible, at Landlord's sole cost, for remedying any pre-existing Hazardous Materials condition related to the Premises (including without limitation, repairs or replacement of HVAC improvements) sufficiently so that the Buildings shall meet any and all applicable indoor air quality standards, including OSHA standards, prior to the Commencement Date.

(c) Mayor's Office of Disability Review; Permits; Termination Right on Account of Delay in Obtaining Permits

Landlord acknowledges that City requires that the Construction Documents be reviewed by the San Francisco Mayor's Office of Disability ("MOD") for compliance with the Americans With Disabilities Act of 1990 ("ADA") and other related laws before Landlord submits them to the appropriate regulatory agencies for construction permits. Landlord shall cause the Architect to submit the Construction Documents to MOD for review promptly following City's approval of the final Construction Documents and MOD shall promptly review the Construction Documents. If MOD requires revisions to the Construction Documents or modifications or additional improvements to the Buildings, Landlord shall cause Architect to revise the Construction Documents and/or design and prepare all additional plans and specifications as required by such MOD review, in conformity with ADA and other legal requirements which MOD shall promptly review. Upon MOD's approval of the Construction Documents, Landlord shall cause Architect to notify Landlord and City that the Construction Documents have been approved and to identify the additional work, if any, specified therein as a result of the MOD review.

Landlord shall secure and pay for any building and other permits and approvals, government fees, licenses and inspections necessary for the proper performance and completion of the Leasehold Improvement Work, the costs of which shall be included in the Final Construction Budget (as defined below). Promptly following MOD's approval of the Construction Documents and City's approval of the Construction Budget (as defined in the following subsection), Landlord shall apply for any permits, approvals or licenses necessary to complete the construction shown on the Construction Documents and shall provide copies to City promptly following receipt thereof. Landlord shall be responsible for arranging for all inspections required by any regulatory agencies.

(d) City's Approval of Costs

As soon as practicable and prior to submitting permit applications for the Leasehold Improvement Work, Landlord shall provide to City, for City's approval, a good faith Final Construction Budget ("Final Construction Budget") based on the Pricing Plans which

includes all project hard and soft costs. City shall have five (5) business days to review and approve or disapprove the Final Construction Budget. If City desires to reduce the Final Construction Budget, Landlord and City shall work in good faith to promptly reduce the scope of work and the Final Construction Budget, and the Construction Plans shall be revised as required to reflect such changes. No costs shall be paid from the Allowance, and City shall not be obligated to pay, any costs unless and until City approves the Final Construction Budget and any revisions thereto.

If during the course of construction, the Leasehold Improvements cannot be completed in strict conformity with the most recently City approved Final Construction Budget, Landlord shall immediately submit to City for its approval a revised Construction Budget and shall identify to City changes in line items and the reasons for the changes. City acknowledges that renovation or improvement of existing facilities inherently involves risk of unanticipated costs necessary to obtain a Final Certificate of Occupancy. If further changes are required, Landlord shall seek City's approval, following the same procedures. City shall not be obligated to pay costs, if any, in excess of the Maximum Leasehold Improvement Cost. If costs exceed the approved Construction Budget, the parties agree to meet and confer in good faith to either (i) obtain City approval of any increased costs, with an appropriation for such amount or (ii) revise the Leasehold Improvement Work so that it does not exceed the Maximum Leasehold Improvement Cost. City shall have the right to reasonably approve or disapprove any Construction Budget or revised Construction Budgets in its reasonable judgment. No such approval or disapproval shall be unreasonably delayed. The most recent City approved Construction Budget shall supersede all previous City approved Construction Budgets. Whenever City approval of the ROM or Construction Budget is required, in the event Landlord and City cannot agree regarding such approval or the Plans require revisions, Landlord's reasonable and necessary costs incurred to produce such revised Plans or ROM or Construction Budget to such date shall be included in the Final Construction Budget.

(e) Construction

Within thirty (30) days, after City's approval of the Construction Documents and the Final Construction Budget and Landlord's procurement of all necessary permits and approvals for the Leasehold Improvements, Landlord shall cause its Contractor to commence construction of the Leasehold Improvements and cause the Leasehold Improvements to be completed in a good and professional manner in accordance with sound building practice. Landlord shall comply with and give notices required by all laws, rules, regulations, ordinances, building restrictions and lawful orders of public authorities bearing on construction of the Leasehold Improvements. Without limiting the foregoing, construction of the Leasehold Improvements shall comply with all applicable disabled access laws, including, without limitation, the most stringent requirements of the ADA, Title 24 of the California Code of Regulations (or its successor) and City's requirements for program accessibility. Landlord shall require in any contract issued in connection with the Leasehold Improvement Work that Contractor shall pay prevailing wages in connection with the Leasehold Improvement Work as further provided in Section 23.24 (Prevailing Wages), below, and shall not use tropical hardwood wood products, or virgin redwood wood products as further provided in Section 23.26 (Tropical Hardwood and Virgin Redwood Ban), below. Landlord shall use commercially reasonable efforts to ensure that Contractor complies with such requirements.

(f) Construction Schedule; Substantial Completion

Landlord shall keep City apprised on a regular basis of the status of plan preparation, permit issuance and the progress of construction. From time to time during the design and construction of the Leasehold Improvements, City shall have the right upon reasonable advance oral or written notice to Landlord to enter the Premises at reasonable times to inspect the Premises and Leasehold Improvement Work, provided such inspections do not unreasonably interfere with the construction. Landlord or its representative may accompany City during any such inspection. When construction progress so permits, but not less than fifteen (15) days in advance of completion, Landlord shall notify City of the approximate date on which the Leasehold Improvement Work will be substantially completed in accordance with the Construction Documents. Landlord shall revise such notice of the approximate substantial completion date as appropriate from time to time and shall immediately notify City when the Leasehold Improvement Work is in fact substantially completed and the Premises are ready for occupancy by City. On such date or other mutually agreeable date as soon as practicable thereafter, City and its authorized representatives shall have the right to accompany Landlord or its architect on an inspection of the Premises, including the Leasehold Improvement Work.

“Substantial Completion” shall be deemed to occur as of the date when the Leasehold Improvements are sufficiently completed in accordance with the approved Construction Documents so that City can occupy the Premises and conduct its business for its intended uses, and Landlord has procured a temporary certificate of occupancy for the Premises and the Architect has certified Substantial Completion pursuant to AIA regulations. City may, at its option, approve the Leasehold Improvements even though there may remain minor details that would not interfere with City’s use. Landlord shall diligently pursue to completion all such details. Notwithstanding the foregoing, City shall have the right to present to Landlord within thirty (30) days after acceptance of the Premises, or as soon thereafter as practicable, a written punchlist consisting of any items that have not been finished in accordance with the Construction Documents. Landlord shall promptly complete all defective or incomplete items identified in such punchlist, and shall in any event complete all items within thirty (30) days after the delivery of such list. City’s failure to include any item on such list shall not alter the Landlord’s responsibility hereunder to complete all Leasehold Improvement Work in accordance with the approved Construction Documents, nor constitute any waiver of any latent defects.

No approval by City or any of its Agents of the Space Plan, Pricing Plans, Construction Drawings, Construction Documents, or completion of the Leasehold Improvement Work for purposes of this Lease shall be deemed to constitute approval of any governmental or regulatory authority with jurisdiction over the Premises, and nothing herein shall limit Landlord’s obligations to obtain all such approvals.

Notwithstanding anything to the contrary herein, in the event that Landlord, after using its best efforts, is unable to (i) obtain all necessary permits, conditional use permits, approvals and/or licenses required to construct the Leasehold Improvements and for City to use and occupy the Premises as contemplated under this Lease, within three (3) months after the Commencement Date, or (ii) substantially complete the Leasehold Improvements within ten (10) months after the Commencement Date, City shall have the right to terminate this Lease upon written notice to Landlord within ten (10) days of such date, without any penalty, fee or other liability.

(g) Appointment of Representatives

City and Landlord shall each designate and maintain at all times during the design and construction period a project representative ("Representative"), and an alternate for such Representative ("Alternate"), each of whom shall be authorized to confer and attend meetings and represent such party on any matter relating to the Leasehold Improvement Work. Landlord and City shall not make any inquiries of or requests to, and shall not give any instructions or authorizations to, any other employee or agent of the other party. The initial Representatives and Alternates shall be:

City: Representative -- Dennis Oates
Alternate -- Andrew Sohn (415) 557-4748
Landlord: Representative -- Karen Lim (650) 796-5784
Alternate -- James Lew (415) 559-2246

Each party may at any time and from time to time change its Representative or Alternate by written notice to the other party. Each party's Representative or Alternate shall be available during ordinary business hours so that questions and problems may be quickly resolved and so that the Leasehold Improvements may be completed economically and in accordance with the Construction Schedule. All approvals made by City's Representative or Alternate shall be made in writing.

(h) Changes to Construction Plans; Tenant Delay

If City inquires (orally or in writing) about any change, addition or alteration relating to the design or specifications of the Leasehold Improvement Work (a "Change Order"), Landlord shall cause its Architect and Contractor to promptly supply a good faith not to exceed change order cost estimate. In the event that a Change Order would delay Substantial Completion, Landlord shall also provide its good faith estimate of such a delay. Within five (5) business days of receipt of such cost and delay estimates, City shall notify Landlord in writing whether City approves the proposed Change Order and an increase in the Construction Budget (if required). If City timely approves the proposed Change Order, then Contractor shall proceed with such Change Order as soon as reasonably practical thereafter. Landlord acknowledges that no one other than the Director of Property or its authorized Representative can request or approve a Change Order. Notwithstanding the foregoing or anything to the contrary, a delay by City in granting consent or approval beyond the time frames specifically set forth in this Lease which directly delays Landlord's performance, shall be deemed a tenant delay ("City Delay") which City Delay shall excuse Landlord's performance of any obligation for the same period as the City Delay and shall delay any termination right available to City under this Lease for the same period as the City Delay.

(i) Cost Reimbursement; Allowance and Additional Leasehold Improvement Allowance

City shall pay for the Leasehold Improvement costs, up to Two Million Three Hundred Thousand Dollars (\$2,300,000), plus a 10% contingency of \$230,000 to be used only

with City's written authorization, for a maximum of Two Million Five Hundred Thirty Thousand Dollars (\$2,530,000) ("City's Contribution").

After the Final Construction Budget has been approved, the Final Construction Budget with a five percent (5%) retention shall be compared to the Allowance to produce a progress payment ratio which will proportionally pay for the cost of the Leasehold Improvement Work from City's Contribution - withholding 5% for final completion of construction, and City shall make progress payments ("Progress Payments") upon invoicing from Landlord to City less a five percent (5%) retention, provided that the conditions set forth herein with respect to documentation of costs have been met, within 30 days of Landlord's submittal of required documentation as provided below. Such applications may not include requests for payment of amounts Landlord does not intend to pay to Contractor because of a dispute or otherwise. Landlord shall promptly apply all such payments from City to the payment of the invoice or invoices to which the payment relates. City shall pay the remaining five percent (5%) withheld from City's prorata share of the cost of the Leasehold Improvement Work upon: (i) expiration of the lien period and the absence of any unreleased mechanics' liens or stop notices; and (ii) Substantial Completion of the Leasehold Improvements and completion or correction of all punch list items.

City shall pay to Landlord, in addition to each Progress Payment amount, for review, supervision, administration and management fees, overhead or other general expenses of Landlord, an amount of three percent (3%) of each Progress Payment. City shall do so promptly following the Landlord's submission and City's receipt and approval of written invoices thereof and of any other required documentation in accordance with this Section 6.2(i).

Subject to this Section 6.2, Landlord shall not be responsible for any Leasehold Improvement costs in excess of the City's Contribution.

(j) Required Documentation of Costs

Landlord shall promptly deliver to City each application for payment pursuant to Section 6.2(i), which shall include (i) copies of all invoices (and industry customary substantiation for the request for such payment) received by Landlord from the Architect or the Contractor in connection with the preparation of the Construction Plans, any Change Order or performance of the Leasehold Improvement Work, (ii) satisfactory evidence of payment of such invoices, including commercially reasonable lien waivers, or if such invoices have not been paid, conditional lien waivers, all such lien waivers being in the applicable form prescribed by California Civil Code sections 8132 and 8134 for Progress Payments and sections 8136 and 8138 for final payments, executed by each subcontractor and material supplier intended to be paid out of the particular disbursement and covering all labor, services, equipment and materials performed or supplied by the particular subcontractor or material supplier since the last previous disbursement (collectively, "Lien Waivers"), and (iii) such additional supporting data which substantiates the Contractor's right to payment as City may reasonably require, such as copies of requisitions from subcontractors and material suppliers. Promptly upon City's request and not later than thirty (30) days after Substantial Completion of the Leasehold Improvements, Landlord shall provide City with copies of a final cost reconciliation. Landlord shall not use any contingency amounts without the prior written consent of City which shall not be unreasonably withheld or delayed. Landlord shall keep a running total of all costs and use of the contingency amounts.

(k) Restoration of the Premises; Removal of Identified Leasehold Improvements

Upon the expiration or sooner termination of this Lease, City shall remove those Leasehold Improvements identified by Landlord that it requires to be removed up on the expiration or earlier termination of this Lease in writing in bold typeface or all capital letters at the time Landlord provides plans and specifications to City for approval, and all other Leasehold Improvements may remain on the expiration or sooner termination of this Lease, in which case such improvements shall become the property of the Landlord and the City shall have no further obligations to restore. Notwithstanding the foregoing, City shall only be obligated to remove Leasehold Improvements that are specialized and have no useful purpose for general users of similar premises, as reasonably determined by Landlord.

6.2 Installation of Telecommunications and Other Equipment

Landlord and City acknowledge that the Leasehold Improvement Work shall be completed by Landlord exclusive of the installation of telecommunications, data and computer cabling facilities, trade fixtures or other equipment personal to City. City shall be responsible for installing such facilities and equipment, provided that Landlord shall furnish access to City and its consultants and contractors to the Premises and Building Systems for which access is needed for proper installation of all such facilities and equipment including, but not limited to, wiring and equipment installations. City shall have the right to enter the Premises during the performance of the Leasehold Improvement Work at reasonable times during the course of construction of the Leasehold Improvements and upon prior consent of Landlord (which shall not be unreasonably withheld or delayed) in order to install such facilities and equipment. City and Landlord shall use their good faith efforts to coordinate any such activities to allow the Leasehold Improvements and the installation of such facilities and equipment to be completed in a timely and cost-effective manner. City shall perform all such work with applicable permits and at the times and in a manner specified by Landlord's Contractor. City shall be responsible for all damage, costs and delays caused by such installation by City.

6.3 Construction of Improvements that Disturb or Remove Exterior Paint

In connection with completion of the Leasehold Improvements, Landlord, on behalf of itself and its successors, assigns and agents, shall comply at Landlord's sole cost with all requirements of applicable local, state, and Federal laws, including but not limited to the California and United States Occupational and Health Safety Acts and their implementing regulations, when the work of improvement or alteration disturbs or removes exterior or interior lead-based or "presumed" lead-based paint (as defined below). Landlord and its Agents shall provide any and all required written notifications to City and any local building department or other applicable agency, at least three (3) business days' prior to any disturbance or removal of exterior or interior lead-based or presumed lead-based paint. Landlord acknowledges that any required notifications to any applicable agency regarding the disturbance or removal of exterior lead-based paint does not constitute notification to City as Tenant under this Lease and similarly that notice under this Lease does not constitute notice under any applicable law. Further, Landlord and its Agents, when disturbing or removing exterior or interior lead-based or presumed lead-based paint, shall not use or cause to be used any of the following methods: (a) acetylene or propane burning and torching; (b) scraping, sanding or grinding without containment barriers or a High Efficiency Particulate Air filter ("HEPA") local vacuum exhaust tool; (c) hydroblasting or high-pressure wash without containment barriers; (d) abrasive blasting

or sandblasting without containment barriers or a HEPA vacuum exhaust tool; and (e) heat guns operating above 1,100 degrees Fahrenheit. Landlord covenants and agrees to comply with the requirements of Title 17 of the California Code of Regulations when taking measures that are designed to reduce or eliminate lead hazards. Under this Section, paint on the exterior or interior of buildings is presumed to be lead-based paint unless a lead-based paint test demonstrates an absence of lead-based paint on the interior or exterior surfaces of such buildings. Under this Section, lead-based paint is "disturbed or removed" if the work of improvement or alteration involves any action that creates friction, pressure, heat or a chemical reaction upon any lead-based or presumed lead-based paint on a surface so as to abrade, loosen, penetrate, cut through or eliminate paint from that surface.

7. ALTERATIONS

7.1 Alterations by City

City shall not make or permit any alterations, installations, additions or improvements (collectively, "Alterations") to the Premises without first obtaining Landlord's written consent, which Landlord shall not unreasonably withhold, condition or delay. All Alterations constructed by Tenant during the Term must be removed upon the expiration of the Term, unless at the time City requests Landlord's approval to a proposed Alteration City also requests Landlord's approval to leave a proposed Alteration at the Premises after the expiration of the Term, in which case Landlord's written consent for the proposed Alteration must specify whether the proposed Alteration may remain at the Premises on the termination of the Term. The installation of furnishings, fixtures, equipment or decorative improvements, none of which affect the Buildings Systems (as defined in Section 8.1) or structural integrity of the Buildings, and the repainting of the interior of the Premises and reflooring of the Premises shall not constitute Alterations requiring Landlord's consent. Any Alterations permitted hereunder shall be made at City's cost in compliance with applicable Laws. Landlord shall, without cost to itself, cooperate with City in securing building and other permits and authorizations needed in connection with any permitted Alterations. Landlord shall not be entitled to any construction or other administrative fee in connection with any Alteration. All Alterations shall be constructed in a good and workmanlike manner by contractors reasonably acceptable to Landlord and only good grades of materials shall be used. All plans and specifications for any Alterations shall be submitted to Landlord for its approval. If Landlord reasonably determines it will need an outside consultant to review the plans and specifications submitted by City for a proposed Alterations, Landlord shall deliver written notice (a "Consultant Review Notice") of such determination and the anticipated costs of such consultant review to City. Landlord shall not engage any consultant to review plans and specifications for any proposed Alterations without first obtaining City's written confirmation that Landlord shall proceed with such review. If City does not provide such written confirmation within ten (10) business days of City's receipt of a Consultant Review Notice, City shall have been deemed to withdrawn its request to have Landlord review the submitted plans and specifications that require such consultant review. Landlord may inspect and observe construction of the Alterations.

City shall reimburse Landlord for its reasonable and necessary costs in reviewing plans and specifications and in monitoring construction, provided such costs shall not exceed the actual, out-of-pocket costs paid by Landlord to third parties plus a construction management fee of (i) one percent (1%) of the actual Structural Cost (defined as follows) of such Alterations. The "Structural Cost" shall be an amount equal to the costs to physically alter the Premises to

make an Alteration and the cost of the Alteration, but shall not include the cost of any personal property or equipment installed as part of such Alteration. Landlord's right to review plans and specifications and to monitor construction shall be solely for its own benefit, and Landlord shall have no duty to see that such plans and specifications or construction comply with all Laws. City shall provide Landlord with the identities and mailing addresses of all third party contractors performing work at, or supplying materials to, the Premises, prior to beginning such construction, and Landlord may post on and about the Premises notices of non-responsibility pursuant to applicable law. Upon completion of any Alterations, City shall deliver to Landlord sworn statements setting forth the names of all contractors and subcontractors who did work on the Alterations and final lien waivers from all such contractors and subcontractors.

Notwithstanding anything to the contrary herein, City shall have the right to perform the following Alterations at its sole cost, subject to Landlord's approval of the plans therefor, but without any fees or charges, which shall not be unreasonably withheld, delayed or conditioned: (i) installing furniture, fixtures or equipment which do not (a) require a permit, (b) affect the Building Systems (defined below), or (c) affect Landlord's repair and maintenance obligations under this Lease, and (ii) voice data and security installations and equipment.

7.2 Title to Improvements

Except for City's Personal Property (as defined in the next Section) and any Alterations that City must remove pursuant to Section 7.1, all appurtenances, fixtures, improvements, equipment, additions and other property permanently installed in the Premises as of the Commencement Date shall be and remain Landlord's property, and all appurtenances, fixtures, improvements, equipment, additions and other property permanently installed in the Premises during the Term shall be City's property until the end of the Term. City may not remove such property unless Landlord consents thereto. Upon surrender of the Premises, all Alterations and any Leasehold Improvements constructed by Landlord or City shall remain on the Premises as Landlord's property, except to the extent Landlord requires removal at City's expense of any identified Alteration at the end of the Term pursuant to Section 7.1 or as otherwise agreed to in writing by Landlord and City. City shall repair any damage caused by the removal of such Alterations upon surrender of the Premises, normal wear and tear and casualty excepted.

7.3 City's Personal Property

All furniture, furnishings, equipment, trade fixtures and articles of movable personal property installed in the Premises by or for the account of City and that can be removed without structural damage to the Premises (collectively, "City's Personal Property") shall be and remain City's property. At any time during the Term or at the expiration thereof, City may remove any of City's Personal Property, provided City shall repair any damage to the Premises resulting therefrom. Upon the expiration or earlier termination of this Lease, City shall remove City's Personal Property from the Premises in accordance with Section 19 (Surrender of Premises), below. Landlord acknowledges that some of City's Personal Property may be financed by an equipment lease financing otherwise subjected to a security interest, or owned by an equipment company and leased to City. Landlord, upon City's reasonable request and provided there is no monetary Event of Default, shall execute and deliver the form of landlord consent and waiver agreement attached hereto as Exhibit F with any supplier, lessor, or lender in connection with the installation or provision in the Premises of any items of City's Personal Property.

7.4 Alteration by Landlord

Landlord shall use its commercially reasonable efforts to minimize interference with or disruption to City's use and occupancy of the Premises during any alterations, installations, additions or improvements to the Buildings, including without limitation any leasehold improvements for other tenants of the Buildings. Landlord shall promptly remedy any such interference or disruption upon receiving City's notice thereof.

8. REPAIRS AND MAINTENANCE

8.1 Landlord's Repairs

Except to the extent caused by the grossly negligent or intentional acts or omissions of City or its agents or contractors or invitees, or the failure of City to perform any maintenance and repair obligations pursuant to this Lease, Landlord shall repair and maintain, at its cost and to a condition of buildings similar age and use in the area, the exterior and structural portions of the Buildings, including, without limitation, the roof, foundation, bearing, and exterior walls, sidewalks and any special monitoring equipment required to remediate any hazardous materials conditions related to the Premises (including repairs or replacements of HVAC improvements) sufficiently so that the Building Systems shall meet any and all applicable indoor air quality standards, including OSHA standards).

"Building Systems" shall mean the heating, ventilating, air conditioning, plumbing, electrical, fire protection, life safety, security and other mechanical, electrical and communications systems located at the Buildings. Landlord, shall repair and maintain, in good condition, any portion of the Building Systems located outside of the Buildings (such as any HVAC components located on a Building roof) and including without limitation, repairs or replacements of HVAC improvements) sufficiently so that the Building Systems shall meet any and all applicable indoor quality standards, including OSHA standards), the electrical and plumbing, glass windows, exterior building doors, fences, connections to the Buildings and other systems to the Property, the main driveway entry, and graffiti removal at the Property.

In performing its obligations hereunder, Landlord shall undertake commercially reasonable measures in accordance with good construction practices to minimize damage, disruption or inconvenience caused by such work and make adequate provision for the safety and convenience of all persons affected by such work. Dust, noise, fumes, odors and other effects of such work shall be controlled using commercially reasonable methods customarily used to control deleterious effects associated with similar projects in occupied buildings (i.e., after-hours core drilling). On written or telephonic notice from City that any repair or replacement is required which is Landlord's obligation hereunder, or otherwise becoming aware of the necessity of such repair, Landlord shall proceed with reasonable diligence to perform such repair or replacement as promptly as possible and shall keep City apprised of its efforts. Without limiting the foregoing, Landlord shall in all events provide City with a written acknowledgement to a written repair or replacement request within five (5) business days of receipt thereof.

8.2 City's Repairs

Subject to Landlord's obligation to deliver the Premises and the Building Systems in good working order, any construction warranties or guaranties received in connection with

Landlord's construction of the Leasehold Improvements and Landlord's repair and maintenance obligations in Section 8.1 above, and Landlord's warranty under Section 10.1, City shall be responsible for separately metering the Premises and shall repair and maintain the interior portions of the Premises in good working order and in a safe and sanitary condition, except for ordinary wear and tear and damage by casualty. City shall be responsible for parking lot and tree maintenance for that portion of the parking lot and landscaping included in the Premises, and shall be responsible for CRAC (Computer Room Air Conditioning) maintenance and repair for CRAC serving the Premises. If installed, City shall also be responsible for the maintenance and repair of any emergency generator or UPS installed and serving the Premises. City shall perform any such required repairs, maintenance and replacements that are City's responsibility hereunder (i) at City's cost, (ii) by contractors or mechanics selected by City and reasonably approved by Landlord, (iii) so that same shall be at least substantially equal in quality, value and utility to the original work or installation prior to damage thereof, (iv) in a manner and using equipment and materials that will not materially interfere with or impair the operations, use or occupation of the Buildings or the Building Systems, and (v) in compliance with all applicable Laws, including, without limitation, any applicable contracting requirements under City's Charter and Administrative Code. Notwithstanding the foregoing to the contrary, City shall have no obligation to make or pay for any structural improvement or modification to the Premises unless triggered by City's Alterations or City's specific use of the Premises or changes to the Laws that take effect after the Commencement Date. Landlord shall assign to City any construction warranty or other warranties or guaranties held by Landlord with respect to the Premises or any part or component thereof, other than warranties with respect to building components which Landlord is obligated to repair and maintain pursuant to the provisions of Section 8.1 above. If City fails to perform any repair or replacement for which it is responsible, Landlord may perform such work and be reimbursed by City for its actual reasonable costs incurred for such work within thirty (30) days after demand therefor, provided that Landlord provided, in an emergency, not less than ten (10) days prior written notice to City and in a non-emergency, not less than one hundred (100) days prior written notice to City of Landlord's intent to perform such work at City's costs.

Notwithstanding anything contained herein to the contrary, Landlord warrants that the Building Systems (including any repairs or replacements to the Building Systems) shall be in a good operating condition for a period of ninety (90) day period after substantial completion of the Leasehold Improvements and subject to extension for latent defects immediately following the completion of the Leasehold Improvements (the "Building Systems Warranty Period"); provided, however, that such warranty shall not be effective for any repairs or replacements necessitated due to the misuse of, lack of maintenance by, or damages caused by, City, its Agents, or Invitees. Additionally, Landlord shall utilize for the benefit of City any warranties provided by the contractors for the work on the Building Systems.

8.3 Liens

City shall keep the Premises free from liens arising out of any work performed, material furnished or obligations incurred by City during the Term. Landlord shall have the right to post on the Premises any notices permitted or required by law or that are needed for the protection of Landlord, the Premises, or the Buildings, from mechanics' and material suppliers' liens. City shall give Landlord at least ten (10) days' prior written notice of commencement of any repair or construction by City on the Premises.

9. UTILITIES AND SERVICES

9.1 Utilities and Services

City shall be responsible for all utilities and services to the Premises. Landlord shall not be liable for any failure or interruption of any utility service furnished to the Premises, and no such failure or interruption shall entitle City to any abatement in Rent or to terminate this Lease, unless such interruption is due to the negligence or willful misconduct of Landlord, and except in connection with Landlord's replacement obligations under Section 8.1 above. Landlord shall use reasonable diligence to make such replacements to Building Systems within the Premises as may be required to restore utility services. Notwithstanding the foregoing, if any interruption in services or utilities is (i) within Landlord's reasonable control and continues for five (5) or more consecutive business days, or (ii) outside Landlord's reasonable control and continues for sixty (60) or more consecutive days, and City is unable to and does not use a material portion of the Premises for City's business purposes as a result thereof, then City shall be entitled to an abatement of rent hereunder, which abatement shall be based on the extent of City's inability to use the Premises.

9.2 Additional Services

City reserves the right to request that the Landlord, at City's cost, perform minor Lease-related services or incur additional expenses not covered under this Lease that the City may require from time to time as reasonably requested by the City and approved by the Real Estate Division, acting through the Director of Property or his or her designee ("Additional Services"), provided that if Landlord, in its sole and absolute discretion, agrees to perform such services or incur such additional expenses, City shall reimburse Landlord for the pre-approved cost for such expenses as Additional Charges within thirty (30) days after receipt of Landlord's invoice therefor. Landlord's charges for the Additional Services may not exceed the rates customarily charged by landlords to tenants or occupants of buildings like the Premises in the Bayshore neighborhood in San Francisco. Landlord shall provide City with invoices for all Additional Services in a format reasonably approved by City. Landlord may add an oversight fee not to exceed three percent (3%) of the charges for the Additional Services Notwithstanding anything to the contrary in this Section, the costs for Additional Services may not exceed ten thousand dollars (\$10,000) in any calendar month.

Without limiting the provisions of Section 9.1 above, City shall be responsible for janitorial service and janitorial supplies, window washing, recycling and refuse removal, pest control, and security for the Premises.

10. COMPLIANCE WITH LAWS; PREMISES CONDITION

10.1 Premises Condition and Landlord's Compliance with Laws; Indemnity

Landlord represents and warrants to City that, to the best of Landlord's knowledge, (a) the physical structure, fixtures and permanent improvements of the Premises (including, without limitation, the Leasehold Improvements) and all portions of the Property and the Buildings along the path of travel to the Premises (including, but not limited to, the Buildings' entrances, and parking areas) as of the Commencement Date will be, in compliance with the requirements of the Americans With Disabilities Act of 1990 and Title 24 of the California Code

of Regulations and all other applicable federal, state, local and administrative laws, rules, regulations, orders and requirements intended to provide equal accessibility for persons with disabilities (collectively, "Disabilities Laws"); (b) neither of the Buildings is not an unreinforced masonry building, and is now, and as of the Commencement Date will be, in compliance with all applicable federal, state, local and administrative laws, rules, regulations, orders and requirements relating to seismic safety (collectively, "Seismic Safety Laws"); (c) the Buildings and Building Systems as of the Commencement Date will be, in full compliance with all applicable federal, state, local and administrative laws, rules, regulations, orders and requirements relating to fire and life safety (collectively, "Life Safety Laws") except to the extent that compliance with such Life Safety Laws arises from City's specific use of the Premises as opposed to the requirements of such Life Safety Laws for the zoning for the Premises; (d) the Buildings and Building Systems as of the Commencement Date will be, in compliance with all other applicable federal, state, local and administrative laws, rules, regulations, orders and requirements (collectively, "Laws"), including without limitation any requirements applicable to Environmental Laws, including without limitation, hazardous materials handling, management, remediation, and indoor air quality; (e) the Buildings and Building Systems were, at the time the Buildings and Building Systems were constructed, in compliance with all other applicable federal, state, local and administrative laws, rules, regulations, orders and requirements in effect at that time; and (f) as of the Commencement Date there will not be, any material physical or mechanical defects in the Premises, Buildings or the Building Systems that would materially adversely affect City's intended use of the Premises. City understands that if City's architects will be designing the Landlord Improvements ("City-Designed Improvements"), then Landlord makes no representation that the design of the City-Designed Improvements will comply with this Section 10.1.

Without limiting the provisions of Section 8 above, in the event that Landlord receives notice that the Premises is not in compliance with applicable Laws in effect at the time that the noncompliant Buildings (or portion thereof) or Building Systems were constructed, including, without limitation, Disabilities Laws, Seismic Safety Laws, and Life Safety Laws, and such non-compliance is not related to City's specific use of the Premises, the design of the City-Designed Improvements, or Alterations to the Premises performed by City, then Landlord shall make such modifications as may be required by order or directive of applicable governmental authority in order to bring the Premises into compliance with applicable Laws as of the Commencement Date without cost or expense to City. Furthermore, in the event Landlord receives notice that the Premises is not in compliance with any applicable Law which come into effect after the Commencement Date and such non-compliance is not related to City's specific use of the Premises or Alterations to the Premises performed by City, Landlord shall make such modifications as may be required by order or directive of applicable governmental authority in order to bring the Premises into compliance with applicable Laws. Landlord's maximum out of pocket compliance costs under this paragraph will be the greater of (1) Two Hundred Thousand Dollars (\$200,000) or (2) the amount of rent payable by Tenant for the remainder of the then-existing term. If Landlord's estimated out-of-pocket costs would exceed the foregoing maximum, then Landlord will have the right to terminate this Lease by giving written notice to City, which will be effective thirty (30) days after City's receipt of the notice; provided, however, that if, upon receipt of Landlord's termination notice, City agrees to pay the amounts over Landlord's maximum out-of-pocket costs, then Landlord's termination notice will be deemed rescinded, Landlord and City will enter into an agreement regarding the amounts to be paid by City, and Landlord will promptly and diligently proceed with the compliance work.

Without limiting Section 16.2 (Landlord's Indemnity), but also subject to any express limitation in Section 16.2, Landlord shall Indemnify City against (i) the costs to bring the Property, Buildings, Building Systems, or any portion thereof, in compliance with applicable Laws in effect prior to the Commencement Date or (ii) any misrepresentation by Landlord under this Section.

10.2 City's Compliance with Laws; Indemnity

City shall use the Premises during the Term in compliance with applicable Laws, except that City shall not be required to make any structural alterations, additions or other modifications in order to comply therewith unless such modifications are necessary solely because of any Alterations to the Premises made by City pursuant to Section 7 hereof and such modifications are not otherwise Landlord's responsibility under this Lease. City shall be responsible for complying with any requirement of the Disabilities Laws relating to the placement of City's furniture or other City Personal Property, City's Alterations, and the operation of any programs in the Premises, other than any requirement relating to the physical structure, fixtures and permanent improvements of the Premises or portions of the Property or Buildings along the path of travel to the Premises, which are Landlord's obligation as provided in Section 10.1 above. Without limiting Section 16.1 (City's Indemnity), City shall Indemnify Landlord against any and all Claims arising out of City's failure to comply with all applicable Laws as provided in this Section.

10.3 City's Compliance with Insurance Requirements

City shall not conduct any use in or about the Premises that would: (a) invalidate or be in conflict with any fire or other casualty insurance policies covering the Buildings or any property located therein, (b) result in a refusal by fire insurance companies of good standing to insure the Buildings or any such property in amounts reasonably satisfactory to Landlord or the holder of any mortgage or deed of trust encumbering the Buildings, (c) cause an increase in the fire insurance premium for the Buildings unless City agrees to pay such increase, or (d) subject Landlord to any liability or responsibility for injury to any person or property by reason solely of any business operation being conducted by City in the Premises; provided, however, Landlord shall provide City with reasonable prior written notice of any applicable insurance requirements and no such insurance requirements shall materially and adversely interfere with City's normal business in the Premises.

11. SUBORDINATION

(a) Without the necessity of any additional document being executed by City for the purpose of effecting a subordination, and subject in all events to subsection (b) below, this Lease shall be subject and subordinate at all times to the following (each an "Encumbrance"):

- (i) any reciprocal easement agreements, ground leases or other underlying leases that may hereafter be executed affecting Landlord's interest in the Premises, or any portion thereof, and
- (ii) the lien of any mortgages or deeds of trust and renewals, modifications, consolidations, replacements and extensions of any of the foregoing that may hereafter be executed by Landlord in any amount for which any part of the Premises, any ground lease or underlying lease, or Landlord's interest or estate therein is subject. Notwithstanding the foregoing, if the ground lessor, mortgagee, trustee, or holder of any such mortgage or deed of trust elects to have City's interest in this Lease be superior to any such instrument, then upon notice thereof to City, this

Lease shall be deemed superior, whether this Lease was executed before or after the date of said instrument or the recording thereof. At City's request, the holder of the Encumbrance shall enter into a subordination and nondisturbance agreement with City in a form reasonably acceptable to City evidencing such subordination or superiority of this Lease. Landlord warrants that as of the date of this Lease there is no existing mortgage or deed of trust encumbering the Premises.

(b) In the event any mortgage or deed of trust to which this Lease is subordinate is foreclosed or a deed in lieu of foreclosure is given to the mortgagee or beneficiary, or in the event any ground lease or underlying lease to which this Lease is subordinate is terminated, this Lease shall not be barred, terminated, cut off, or foreclosed nor shall the rights and possession of City hereunder be disturbed if City shall not then be in default in the payment of rental or other sums due hereunder or otherwise be in default under the terms of this Lease beyond any applicable notice and cure period. City shall attorn to and become the tenant of the successor-in-interest to Landlord, provided that City has received proper written notice of such succession and the name and address of the successor landlord. City's covenant under subsection (a) above to subordinate this Lease to any Encumbrance or other hypothecation hereafter executed is conditioned upon each such senior instrument containing the commitments specified in this subsection (b). The provisions of this Section shall be self-operative and no further instrument shall be required other than as provided in this Section. City agrees, however, to execute upon request by Landlord and in a form reasonably acceptable to City, any additional documents evidencing the priority or subordination of this Lease with respect to any such Encumbrance as provided herein.

12. DAMAGE AND DESTRUCTION

12.1 Minor Damage

If the Premises, the Buildings or any Building Systems are damaged by fire or other casualty not principally resulting from any willful or negligent act or omission of City, its Agents or its Invitees, such that less than 33% of the Premises is deemed to not be of beneficial use to the City, Landlord shall repair the same without delay (and if Landlord is then carrying insurance on the Alterations or if City at its sole option makes funds available to Landlord, Landlord shall also repair the Alterations), provided that such repairs can be made under applicable laws within sixty (60) days after Landlord obtains all necessary permits for such repairs but not later than one hundred eighty (180) days after the date of such damage (the "Repair Period"). In such event, this Lease shall remain in full force and effect, except that City shall be entitled to an abatement of Rent while such repairs are being made. Such abatement in Rent shall be based upon the extent to which such damage and the making of such repairs interfere with City's business in the Premises. Landlord's repairs shall not include, and the Rent shall not be abated as a result of, any damage by fire or other cause to City's Personal Property.

Within forty-five (45) days after the date of such damage, Landlord shall notify City whether or not, in Landlord's reasonable judgment made in good faith, such repairs can be made within the Repair Period ("Repair Notice"). If such repairs cannot be made within the Repair Period, then City may, by written notice, terminate this Lease as of the date specified in City's notice. In case of termination, the Rent shall be reduced by a proportionate amount based upon the extent to which such damage interferes with the conduct of City's business in the Premises, and City shall pay such reduced Rent up to the date of termination. Landlord shall refund to City any Rent previously paid for any period of time subsequent to such date of termination.

12.2 Major Damage

If the Premises, the Buildings or any Building Systems are damaged by fire or other casualty not principally resulting from any willful or grossly negligent act or omission of City, its Agents or its Invitees, such that 33% or more of the Premises is deemed to not be of beneficial use to the City, Landlord shall repair the same without delay (and if Landlord is then carrying insurance on the Alterations or if City at its sole option makes funds available to Landlord, Landlord shall also repair the Alterations), provided that such repairs can be made under applicable laws within sixty (60) days after Landlord obtains all necessary permits for such repairs but not later than one hundred eighty (180) days after the date of such damage (the "Major Repair Period"). In such event, this Lease shall remain in full force and effect, except that City shall be entitled to an abatement of Rent while such repairs are being made. Such abatement in Rent shall be based upon the extent to which such damage and the making of such repairs interfere with City's business in the Premises. Landlord's repairs shall not include, and the Rent shall not be abated as a result of, any damage by fire or other cause to City's Personal Property.

Within forty five (45) days after the date of such damage, Landlord shall notify City whether or not, in Landlord's reasonable judgment made in good faith, such repairs can be made within the Major Repair Period ("Major Repair Notice"). If such repairs cannot be made within the Major Repair Period, then City may, by written notice, terminate this Lease as of the date specified in City's notice.

In case of termination, the Rent shall be reduced by a proportionate amount based upon the extent to which such damage interferes with the conduct of City's business in the Premises, and City shall pay such reduced Rent up to the date of termination. Landlord shall refund to City any Rent previously paid for any period of time subsequent to such date of termination.

13. EMINENT DOMAIN

13.1 Definitions

(a) "Taking" means a taking or damaging, including severance damage, by eminent domain, inverse condemnation or for any public or quasi-public use under law. A Taking may occur pursuant to the recording of a final order of condemnation, or by voluntary sale or conveyance in lieu of condemnation or in settlement of a condemnation action.

(b) "Date of Taking" means the earlier of (i) the date upon which title to the portion of the Premises taken passes to and vests in the condemnor or (ii) the date on which Tenant is dispossessed.

(c) "Award" means all compensation, sums or anything of value paid, awarded or received for a Taking, whether pursuant to judgment, agreement, settlement or otherwise.

13.2 General

If during the Term or during the period between the execution of this Lease and the Commencement Date, there is any Taking of all or any part of the Premises or any interest in this Lease, the rights and obligations of the parties hereunder shall be determined pursuant to this

Section. City and Landlord intend that the provisions hereof govern fully in the event of a Taking and accordingly, the parties each hereby waive any right to terminate this Lease in whole or in part under Sections 1265.110, 1265.120, 1265.130 and 1265.140 of the California Code of Civil Procedure or under any similar law now or hereafter in effect.

13.3 Total Taking; Automatic Termination

If there is a total Taking of the Premises, then this Lease shall terminate as of the Date of Taking.

13.4 Partial Taking; Election to Terminate

(a) If there is a Taking of any portion (but less than all) of the Premises, then this Lease shall terminate in its entirety if all of the following exist: (i) the partial Taking, in City's reasonable judgment, renders the remaining portion of the Premises untenable or unsuitable for continued use by City for its intended purposes or otherwise materially adversely affects City's normal operations in the Premises, (ii) the condition rendering the Premises untenable or unsuitable either is not curable or is curable but Landlord is unwilling or unable to cure such condition, and (iii) City elects to terminate.

(b) In the case of a partial taking of over forty percent (40%) of the Premises, and if subsection (a) above does not apply, City and Landlord shall each have the right to terminate this Lease by written notice to the other within thirty (30) days after the Date of Taking, provided that, as a condition to City's right to terminate, the portion of the Premises taken shall, in City's reasonable judgment, render the Premises unsuitable for continued use by City for its intended purposes or otherwise materially adversely affect City's normal operations in the Premises.

(c) Either party electing to terminate under the provisions of this Section 13.4 shall do so by giving written notice to the other party before or within thirty (30) days after the Date of Taking, and thereafter this Lease shall terminate upon the later of the thirtieth (30th) day after such written notice is given or the Date of Taking.

13.5 Termination of Lease; Rent and Award

Upon termination of this Lease pursuant to an election under Section 13.4 above, then: (a) City's obligation to pay Rent shall continue up until the date of termination and thereafter shall cease, except that Rent shall be reduced as provided in Section 13.6 below for any period during which this Lease continues in effect after the Date of Taking, and (b) Landlord shall be entitled to the entire Award in connection therewith, except that City shall receive any Award made specifically for City's relocation expenses or the interruption of or damage to City's business or damage to City's Personal Property.

13.6 Partial Taking; Continuation of Lease

If there is a partial Taking of the Premises under circumstances where this Lease is not terminated in its entirety under Section 13.4 above, then this Lease shall terminate as to the portion of the Premises so taken, but shall remain in full force and effect as to the portion not taken, and the rights and obligations of the parties shall be as follows: (a) Rent shall be reduced

by an amount that is in the same ratio to the Rent as the area of the Premises taken bears to the area of the Premises prior to the Date of Taking, and (b) Landlord shall be entitled to the entire Award in connection therewith, provided that City shall receive any Award made specifically for City's relocation expenses or the interruption of or damage to City's business or damage to City's Personal Property.

13.7 Temporary Taking

Notwithstanding anything to contrary in this Section, if a Taking occurs with respect to the Premises for a limited period of time not in excess of sixty (60) consecutive days, this Lease shall remain unaffected thereby, and City shall continue to pay Rent and to perform all of the terms, conditions and covenants of this Lease. In the event of such temporary Taking, City shall be entitled to receive that portion of any Award representing compensation for the use or occupancy of the Premises during the Term up to the total Rent owing by City for the period of the Taking.

14. ASSIGNMENT AND SUBLETTING

City shall not directly or indirectly sell, assign, encumber, pledge or otherwise transfer or hypothecate all or any part of its interest in or rights with respect to the Premises or its leasehold estate hereunder or sublet all or any portion of the Premises. Use of all or any part of the Premises by any City departments shall not be subject to Landlord approval; provided, however, that City shall use commercially reasonable efforts to provide Landlord with advance written notice of use by City other than as a Navigation Center.

15. DEFAULT; REMEDIES

15.1 Events of Default by City

Any of the following shall constitute an Event of Default by City hereunder:

(a) City's failure to make any timely payment of Rent and to cure such nonpayment within five (5) business days after receipt of written notice thereof from Landlord, provided that for the first two (2) monthly payments of Rent at the beginning of the Term and for the first monthly payment of Rent following any Adjustment Date, City shall have twenty (20) days to cure any such nonpayment after written notice thereof from Landlord;

(b) City's abandonment of the Premises (within the meaning of California Civil Code Section 1951.3); or

(c) City's failure to perform any other covenant or obligation of City hereunder (not involving the payment of money) and to cure such non-performance within thirty (30) days of the date of receipt of notice thereof from Landlord, provided that if more than thirty (30) days are reasonably required for such cure, no Event of Default shall occur if City commences such cure within such period and diligently prosecutes such cure to completion.

15.2 Landlord's Remedies

Upon the occurrence of any Event of Default that is not cured within the applicable grace period as provided above, Landlord shall have all rights and remedies available pursuant to law

or granted hereunder, including the rights and remedies provided by California Civil Code Section 1951.2 (damages on termination for breach), including, but not limited to, the right to terminate City's right to possession of the Premises and to recover the worth at the time of award of the amount by which the unpaid Rent for the balance of the Term after the time of award exceeds the amount of rental loss for the same period that City proves could be reasonably avoided, as computed pursuant to subsection (b) of such Section 1951.2.

15.3 Landlord's Default

If Landlord fails to perform any of its obligations under this Lease, then (without limiting any of City's other cure rights under this Lease) City may, at its sole option, cure such default at Landlord's expense if such default continues twenty-five (25) days after written notice from City specifying such failure (unless such performance will, due to the nature of the obligation, require a period of time in excess of 25 days, then after such period of time as is reasonably necessary if Landlord commences to cure such failure during the original 25-day period and diligently pursues such cure to completion); provided, however, that if such Landlord failure results in an emergency, Landlord shall be in default hereunder if Landlord fails to perform any of its obligations hereunder within ten (10) days after written notice from City specifying such failure (unless such performance will, due to the nature of the obligation, require a period of time in excess of ten (10) days, then after such period of time as is reasonably necessary if Landlord commences to cure such failure during the original 10-day period and diligently pursues such cure to completion). For the purposes of the foregoing sentence, an "emergency" shall mean an imminent threat of personal injury to City's employees or material damage to City's equipment or other property at the Premises and such repairs shall be deemed "Emergency Repairs." Subject to the other provisions of this Lease relating to abatement of Rent, if Landlord fails to cure any default within the cure period provided above, then, whether or not City elects to cure Landlord's default as provided herein, the Base Rent and any other charges hereunder shall be abated based on the extent to which such default interferes with City's ability to carry on its business at the Premises. Notwithstanding the foregoing, if any such default by Landlord continues for sixty (60) days and impairs City's ability to carry on its business in the Premises, then City shall have the right to terminate this Lease upon written notice to Landlord within thirty (30) days after the expiration of such sixty (60)-day period.

In the event that City delivers written notice of a Landlord default on an Emergency Repair and Landlord does not timely commence to cure such default on an Emergency Repair within the time periods set forth above (or if Landlord timely commences such cure but fails to diligently pursue such cure to completion), City shall have the right, but not the obligation, to make any reasonable and necessary repairs to the roof, foundation, floors and exterior walls of the Premises, the roof membrane, skylights, roof vents, drains and downspouts of the Premises, and the exterior and under slab utility systems for the Premises, as may be reasonably necessary to prevent material damage to the equipment or property of City situated in the Premises, material interference with City's operations at the Premises, or personal injury to City's employees, provided City has no reasonable alternative and has notified or attempted in good faith to notify Landlord's representative of such election by telephone (with subsequent written notice as soon as practicable). The provisions of this paragraph do not designate City as Landlord's agent for the purposes of any such repairs. Landlord shall reimburse City for the reasonable, out-of-pocket costs incurred by City in making such Emergency Repairs to the roof, foundation or exterior walls, as applicable, up to (but not to exceed) \$25,000.00 with respect to

each such occurrence, within thirty (30) days after submission by City to Landlord of an invoice therefore, accompanied by reasonable supporting documentation for the costs so incurred. In the event Landlord fails or refuses to reimburse City for such costs within such thirty (30) day period and City brings an action for recovery of such amounts from Landlord as provided for in this Lease, then City shall be entitled to recover, in addition to the amount of such costs, interest on such amounts from the date incurred by City until recovered from Landlord, at the interest rate the rate of ten percent (10%) per year, and the reasonable attorneys' fees and other costs of court incurred by City in pursuing such action.

City's rights hereunder and under Section 3.3 (Delay in Delivery of Possession), Section 5.3 (Interference with Access and Use), and Section 9.1 (Utilities and Services), shall not limit in any way any of its other rights and remedies hereunder or at law or in equity.

16. INDEMNITIES

16.1 City's Indemnity

City shall indemnify, defend and hold harmless ("Indemnify") Landlord and its Agents from and against any and all claims, actions, suits, damages, liabilities, obligations, costs, and expenses, including, without limitation, punitive damages and reasonable attorneys' fees (collectively, "Claims"), incurred as a result of (a) City's use of the Premises, (b) any Event of Default arising from City's failure to perform any of its material obligations under this Lease, or (c) any negligent acts or omissions of City or its Agents or Invitees in, on or about the Premises; provided, however, City shall not be obligated to Indemnify Landlord or its Agents to the extent any Claim arises out of the negligence or willful misconduct of Landlord or its Agents. In any action or proceeding brought against Landlord or its Agents by reason of any Claim Indemnified by City hereunder, City may, at its sole option, elect to defend such Claim by attorneys in City's Office of the City Attorney, by other attorneys selected by City, or both. City shall have the right to control the defense and to determine the settlement or compromise of any action or proceeding, provided that Landlord shall have the right, but not the obligation, to participate in the defense of any such Claim at its sole cost. City's obligations under this Section shall survive the termination of the Lease.

16.2 Landlord's Indemnity

Landlord shall Indemnify City and its Agents against any and all Claims incurred as a result of (a) any default by Landlord in the performance of any of its obligations under this Lease or any breach of any representations or warranties made by Landlord under this Lease, or (b) any negligent acts or omissions of Landlord or its Agents in, on or about the Premises; provided, however, Landlord shall not be obligated to Indemnify City or its Agents to the extent any Claim arises out of the negligence or willful misconduct of City or its Agents. In any action or proceeding brought against City or its Agents by reason of any Claim Indemnified by Landlord hereunder, Landlord may, at its sole option, elect to defend such Claim by attorneys selected by Landlord. Landlord shall have the right to control the defense and to determine the settlement or compromise of any action or proceeding, provided that City shall have the right, but not the obligation, to participate in the defense of any such Claim at its sole cost. Landlord's obligations under this Section shall survive the termination of this Lease.

16.3 City's Self-Insurance

Landlord acknowledges that City maintains a program of self-insurance and agrees that City shall not be required to carry any insurance with respect to this Lease. City assumes the risk of damage to any of City's Personal Property and any Alterations constructed by City resulting from those causes for which Landlord is not required to indemnify City hereunder.

16.4 Landlord's Insurance

At all times during the Term, Landlord shall keep the Buildings (excluding the land upon which it is located) insured against damage and destruction by fire, vandalism, malicious mischief, sprinkler damage and other perils customarily covered under a cause of loss-special form property insurance policy in an amount equal to one hundred percent (100%) of the full insurance replacement value (replacement cost new, including, debris removal and demolition) thereof. Landlord shall, upon request by City, provide to City a certificate of insurance issued by the insurance carrier, evidencing the insurance required above. The certificate shall expressly provide that the policy is not cancelable or subject to, reduction of coverage or otherwise subject to modification except after thirty (30) days prior written notice to City. Landlord hereby waives any rights against City for loss or damage to the Premises or any other part of the Property, to the extent covered by Landlord's property insurance.

In addition, Landlord, shall procure and keep in effect at all times during the Term insurance as follows: Commercial general liability insurance with limits not less than Two Million Dollars (\$2,000,000) each occurrence combined single limit for bodily injury and property damage, including contractual liability, independent contractors, broad-form property damage, fire damage legal liability (of not less than Fifty Thousand Dollars (\$50,000)), personal injury, products and completed operations, and explosion, collapse and underground (XCU).

The Premises or Buildings may be included in a blanket policy.

16.5 Waiver of Subrogation

Notwithstanding anything to the contrary in this Lease, Landlord hereby waives any right of recovery against City for any loss or damage relating to the Buildings or the Premises or any operations or contents therein, whether or not such loss is caused by the fault or negligence of City, to the extent such loss or damage is covered by insurance that Landlord is required to purchase under this Lease or is otherwise actually recovered from insurance held by Landlord or its agents. Landlord agrees to obtain a waiver of subrogation endorsement from applicable insurance carriers issuing policies relating to the Buildings or the Premises; provided, Landlord's failure to do so shall not affect the above waiver.

17. ACCESS BY LANDLORD

Landlord reserves for itself and any designated Agent the right to enter the Premises at all reasonable times and, except in cases of emergency (in which event Landlord shall give any reasonable notice), after giving City at least twenty four (24) hours' advance written or oral notice, for the purpose of (a) inspecting the Premises, (b) supplying any service to be provided by Landlord hereunder, (c) during the last twelve (12) months of the Term, showing the Premises to any prospective purchasers, mortgagees or tenants, , (d) posting notices of non-responsibility,

and (e) altering, improving or repairing the Premises and any portion of the Buildings, and Landlord may for that purpose erect, use and maintain necessary structures in and through the Premises where reasonably required by the character of the work to be performed, provided that the entrance to the Premises shall not be blocked thereby, and further provided that City's use shall not be interfered with.

18. ESTOPPEL CERTIFICATES

Either party, from time to time during the Term upon not less than twenty (20) days' prior written notice from the other party, may reasonably request the other party to execute, acknowledge and deliver to such persons or entities designated by such other party a certificate, for Tenant, substantially in the form of the Tenant's Estoppel Certificate attached hereto as Exhibit G and for Landlord, in a form reasonably acceptable to City, stating: (a) the Commencement Date, the Rent Commencement Date, and Expiration Date of this Lease, (b) that this Lease is unmodified and in full force and effect (or, if there have been modifications, this the Lease is in full force and effect as modified and stating the modifications), (c) that there are no defaults under this Lease (or if so, specifying the same), and (d) the date to which Rent has been paid.

19. SURRENDER OF PREMISES

Upon the expiration or sooner termination of this Lease, City shall surrender the Premises to Landlord in "broom clean" condition, in the same condition received, reasonable use and wear and damage by fire or other casualty excepted. Prior to the Expiration Date, City shall remove from the Premises all of City's Personal Property, and any Alterations City is required to remove from the Premises pursuant to the provisions of Section 6.1(k) or Section 7.1 (Alterations by City), above. City shall repair or pay the cost of repairing any damage to the Premises or the Buildings resulting from such removal. Notwithstanding anything to the contrary in this Lease, except as provided in Section 6.1(k), City shall not be required to demolish or remove from the Premises any of the Leasehold Improvements. City's obligations under this Section shall survive the expiration or earlier termination of this Lease.

20. HAZARDOUS MATERIALS

20.1 Definitions

As used in this Lease, the following terms shall have the meanings hereinafter set forth:

(a) "Environmental Laws" shall mean any federal, state, local or administrative law, rule, regulation, order or requirement relating to industrial hygiene, environmental conditions or Hazardous Material, whether now in effect or hereafter adopted.

(b) "Hazardous Material" shall mean any material that, because of its quantity, concentration or physical or chemical characteristics, is deemed by any federal, state or local governmental authority to pose a present or potential hazard to human health or safety or to the environment. Hazardous Material includes, without limitation, any material or substance defined as a "hazardous substance," or "pollutant" or "contaminant" pursuant to the Comprehensive Environmental Response, Compensation and Liability Act of 1980 ("CERCLA", also commonly known as the "Superfund" law), as amended (42 U.S.C. Section 9601 et seq.), or pursuant to

Section 25316 of the California Health & Safety Code; any "hazardous waste" listed pursuant to Section 25140 of the California Health & Safety Code; any asbestos and asbestos containing materials whether or not such materials are part of the structure of the Buildings or are naturally occurring substances on or about the Property; and petroleum, including crude oil or any fraction thereof, natural gas or natural gas liquids, liquefied natural gas, or synthetic gas usable for fuel (or mixtures of natural gas and such synthetic gas). As defined in Environmental Laws, during the Term, City is and shall be deemed to be the "operator" of City's "facility" and the "owner" of all Hazardous Materials brought on the Premises by City, its Agents or Invitees, and the wastes, by-products, or residues generated, resulting or produced therefrom.

(c) "Release" when used with respect to Hazardous Material shall include any actual or imminent spilling, leaking, pumping, pouring, emitting, emptying, discharging, injecting, escaping, leaching, dumping, or disposing into or inside the Buildings, or in, on, under or about the Property.

20.2 Landlord's Representations and Covenants

Landlord represents and warrants to City that, to the best of Landlord's knowledge, the following statements are true and correct and will be true and correct as of the Commencement Date (a) the Property is not in violation of any Environmental Laws; (b) the Property is not now, nor has it been, used for the manufacture, use, storage, discharge, deposit, transportation or disposal of any Hazardous Material, except for the use of such substances in such limited quantities as are customarily used in offices, which limited use has been and is in compliance with Environmental Laws; (c) the Property does not consist of any landfill or contain any underground storage tanks; (d) the Buildings do not consist of any asbestos-containing materials or building materials that contain any other Hazardous Material, nor do the Premises or the common areas of the Buildings contain any lead-based paints; (e) there has been and is no Release of any Hazardous Material in the Buildings or in, on, under or about the Property; and (f) the Property is not subject to any claim by any governmental regulatory agency or third party related to the Release of any Hazardous Material, and there is no inquiry by any governmental agency (including, without limitation, the California Department of Toxic Substances Control or the Regional Water Quality Control Board) with respect to the presence of Hazardous Material in the Buildings or in, on, under or about the Property, or the migration of Hazardous Material from or to other real property. Subject to City's obligations under this Section below, Landlord shall maintain the Property throughout the Term in compliance with all Environmental Laws that could affect the health, safety and welfare of City's employees or City's use, occupancy or enjoyment of the Premises for their intended purposes.

20.3 Landlord's Covenants

If Hazardous Materials in addition to those disclosed in the documents and information listed in Exhibit C-1 are hereafter discovered on the Premises, and such Hazardous Materials either existed at the Premises prior to the Commencement Date or were released by any party other than City or its Agents or Invitees, and the presence of such Hazardous Materials results in any contamination, damages, or injury to the Premises that materially and adversely affects City's occupancy or use of the Premises or human health or requires remediation under Environmental Laws, Landlord shall promptly take all actions at its sole expense as are necessary to remediate such Hazardous Materials, but only to the extent as required by the Environmental Laws. Actual or threatened action or litigation by any governmental authority is

not a condition prerequisite to Landlord's obligations under this Section. Landlord's obligations under this Section shall not apply to any remediation of such Hazardous Materials to the extent released by any act or omission of City or its Agents, or Invitees. Within thirty (30) days after notification from City supported by reasonable documentation setting forth such presence or release of Hazardous Materials, and after Landlord has been given a reasonable period of time after such thirty (30) day period to conduct its own investigation to confirm such presence or release of Hazardous Materials, Landlord shall, but only if required to comply with the Environmental Laws, commence to remediate such Hazardous Materials within one hundred eighty (180) days after the completion of Landlord's investigation and thereafter diligently prosecute such remediation to completion. If Landlord commences remediation pursuant to this Section, the Base Rent shall be equitably adjusted if and to the extent and during the period the Premises are unsuitable for City's business. Notwithstanding anything herein to the contrary, if Landlord obtains a letter from the appropriate governmental authority that no further remediation or action is required, Landlord's obligation to remediate as provided in this Section shall be null and void as of the date Landlord receives such letter.

20.4 Landlord's Environmental Indemnity

Without limiting Landlord's Indemnity in Section 16.2 (Landlord's Indemnity), above, Landlord shall Indemnify City and its Agents against any and all Claims arising during or after the Term of this Lease (a) as a result of any breach of any of Landlord's representations, warranties or covenants in the preceding Section, or (b) in connection with any presence or Release of Hazardous Material in the Buildings or on, under or about the Property, unless City or its Agents caused such Release.

20.5 City's Covenants

City, its Agents and Invitees shall not permit or cause any Hazardous Material to be brought upon, kept, used, stored, generated or disposed of in, on or about the Premises or the Property, or transported to or from the Premises or the Property, except as expressly permitted in this Section below. City, at its sole cost and expense, shall operate its business in the Premises in strict compliance with all Environmental Laws and shall remediate in a manner satisfactory to Landlord any Hazardous Materials released on or from the Premises by City, its Agents, or its Invitees. City shall complete and certify to disclosure statements as reasonably requested by Landlord from time to time relating to City's transportation, storage, use, generation, manufacture or release of any Hazardous Materials on the Premises. Without limiting the uses which are permitted under the terms of this Lease, Landlord acknowledges that City may use the Premises for the Permitted Uses and connection with such uses may use substances such as cleaning fluids, gasoline, diesel and other vehicle fluids, paints and solvents, including the materials listed on the attached Exhibit C-2, so long as such use is in compliance with all applicable Environmental Laws. No cure or grace period provided in this Lease shall apply to City's obligations to comply with the terms and conditions of this Section.

Landlord shall have access to, and a right to perform inspections and tests of, the Premises to determine City's compliance with Environmental Laws, its obligations under this Section, or the environmental condition of the Premises; provided that such inspections and tests do not materially interfere with the Permitted Uses. Access shall be granted to Landlord upon not less than one (1) business days' prior notice to City and at such times so as to minimize, so far as may be reasonable under the circumstances, any disturbance to City's operations. Such

inspections and tests shall be conducted at Landlord's expense, unless such inspections or tests reveal that City has not complied with any Environmental Requirement, in which case City shall reimburse Landlord for the reasonable cost of such inspection and tests. Landlord's receipt of or satisfaction with any environmental assessment in no way waives any rights that Landlord holds against City. Except for Hazardous Materials released by City or its Agents or Invitees, Landlord shall be the generator of, and responsible party for, any Hazardous Material released or disturbed by the performance of such Landlord inspections or tests and shall take immediate actions to stop and remediate any such release, to properly dispose of any Hazardous Material removed from the Premises as part of such Landlord inspections or tests, notify City about any such release and remediate any Hazardous Material to the extent it was released or otherwise disturbed through the performance of such Landlord inspections or tests.

20.6 City's Environmental Indemnity

If City breaches its obligations contained in the preceding Section 20.5, or if City or its Agents cause the Release of Hazardous Material from, in, on or about the Premises or the Property, then City shall Indemnify Landlord against any and all Claims arising during or after the Term of this Lease as a result of such Release, except to the extent Landlord or its Agents is responsible for the Release. The foregoing Indemnity shall not include any Claims resulting from the non-negligent aggravation by City, its Agents or Invitees of physical conditions of the Premises, or other parts of the Property, existing prior to City's occupancy. The obligations of City under this Section shall survive any termination of this Lease.

21. SPECIAL PROVISIONS

21.1 Extension Right

(a) Exercise of Extension Option

City shall have the option to extend the Term for five (5) consecutive additional periods of one (1) year each (each, an "Extension Term"), commencing on the day immediately following the original scheduled expiration date of the Term or the expiration of any prior Extension Term. City shall give Landlord notice (hereinafter called the "Extension Exercise Notice") of its election to extend the Term (subject to approval of funds from City's Controller, if and as required) for the first Extension Term, at least one hundred twenty days (120) days before the then-scheduled expiration date of the Term, and for each Extension Term thereafter at least one hundred eighty (180) days prior to the then-scheduled expiration date of the Term.

(b) Terms and Conditions; Base Rent for Extension Term

During each Extension Term all of the terms and conditions set forth in this Lease as applicable to the Premises during the initial term shall apply, except that (i) City shall take the Premises in their then "as-is" state and condition (subject to any warranties and Landlord's obligation to repair and maintain set forth herein), and (ii) the Base Rent payable by City to Landlord during an Extension Term shall be one hundred three percent (103%) of Base Rent in effect for the last full month immediately before the commencement of the Extension Term.

(c) General Provisions

The following general provisions shall apply to each Extension Option:

(i) After the Base Rent payable during the applicable Extension Term is determined (i.e., 103% of the Base Rent payable in the last full month of the initial term or prior Extension Term, as applicable), the parties shall promptly execute an amendment to this Lease in a form reasonably acceptable to both parties, memorializing the extension of the Term and stating the amount of the Base Rent payable during the applicable Extension Term.

(ii) Subject to the provisions of this Section 21.1, after exercise of an Extension Option, all references in this Lease to the Term shall be deemed to refer to the Term as extended, unless the context clearly provides to the contrary.

(iii) If City shall fail to timely exercise an Extension Option, the applicable Extension Option and any subsequent Extension Option shall terminate and be of no further force and effect. If this Lease shall terminate for any reason, then immediately upon such termination all Extension Options shall simultaneously terminate and become null and void.

21.2 Intentionally Deleted

22. GENERAL PROVISIONS

22.1 Notices

Except as otherwise specifically provided in this Lease, any notice given under this Lease shall be in writing and given by delivering the notice in person or by commercial courier, or by sending it by first-class mail, certified mail, return receipt requested, or Express Mail, return receipt requested, with postage prepaid, to: (a) City at City's address set forth in the Basic Lease Information; or (b) Landlord at Landlord's address set forth in the Basic Lease Information; or (c) such other address as either Landlord or City may designate as its new address for such purpose by notice given to the other in accordance with this Section. Any notice hereunder shall be deemed to have been given and received two (2) days after the date when it is mailed if sent by first-class, certified mail, one day after the date when it is mailed if sent by Express Mail, or upon the date personal delivery is made. For convenience of the parties, copies of notices may also be given by email to the email address set forth in the Basic Lease Information or such other address as may be provided from time to time; however, neither party may give official or binding notice by email and the date that a notice is deemed given will be the date determined under the preceding sentence, regardless of the receipt of a notice by email.

22.2 No Implied Waiver

No failure by either party to insist upon the strict performance of any obligation of the other party under this Lease or to exercise any right, power or remedy consequent upon a breach thereof shall constitute a waiver of any such breach or of such term, covenant or condition. No acceptance of full or partial Rent by Landlord while City is in default hereunder shall constitute a waiver of such default by Landlord. No express written waiver of any default or the performance of any provision hereof shall affect any other default or performance, or cover any other period of time, other than the default, performance or period of time specified in such express waiver. One or more written waivers of a default or the performance of any provision hereof shall not be deemed to be a waiver of a subsequent default or performance. The consent of Landlord or City given in one instance under the terms of this Lease shall not relieve the other party of any obligation to secure the consent to any other or future instance under the terms of the Lease.

22.3 Amendments

Neither this Lease nor any terms or provisions hereof may be changed, waived, discharged or terminated, except by a written instrument signed by the party against which the enforcement of the change, waiver, discharge or termination is sought. No waiver of any breach shall affect or alter this Lease, but each and every term, covenant and condition of this Lease shall continue in full force and effect with respect to any other then-existing or subsequent breach thereof. Whenever this Lease requires or permits the giving by City of its consent or approval, the Director of Property, or his or her designee, shall be authorized to provide such approval, except as otherwise provided by applicable law, including the Charter of the City and County of San Francisco. Any amendments or modifications to this Lease, including, without limitation, amendments to or modifications to the exhibits to this Lease, shall be subject to the mutual written agreement of City and Landlord, and City's agreement may be made upon the sole approval of the Director of Property, or his or her designee; provided, however, material amendments or modifications to this Lease (a) changing the legal description of the Premises, (b) increasing the Term, (c) increasing the Rent, (d) changing the general use of the Premises from the use authorized under Section 5.1 of this Lease, and (e) any other amendment or modification which materially increases City's liabilities or financial obligations under this Lease shall additionally require the approval of City's Board of Supervisors.

22.4 Authority

Landlord represents and warrants to City that the execution and delivery of this Lease by Landlord has been duly authorized and does not violate any provision of any agreement, law or regulation to which Landlord or the Property is subject.

22.5 Parties and Their Agents; Approvals

If applicable, the word "Landlord" as used in this Lease shall include the plural as well as the singular. As used in this Lease, the term "Agents" when used with respect to either party shall include the agents, employees, officers, contractors and subcontractors of such party, and the term "Invitees" when used with respect to City shall include the clients, customers, invitees, guests, licensees, assignees or subtenants of City. All approvals, consents or other determinations permitted or required by City under this Lease, including but not limited to the

exercise of any option granted to City, shall be made by or through City's Director of Property unless otherwise provided in this Lease, subject to any applicable limitations in the City's Charter.

22.6 Interpretation of Lease

The captions preceding the articles and sections of this Lease and in the table of contents have been inserted for convenience of reference only and such captions shall in no way define or limit the scope or intent of any provision of this Lease. This Lease has been negotiated at arm's length and between persons sophisticated and knowledgeable in the matters dealt with herein and shall be interpreted to achieve the intent and purposes of the parties, without any presumption against the party responsible for drafting any part of this Lease. Except as otherwise specifically provided herein, wherever in this Lease Landlord or City is required or requested to give its consent or approval to any matter or action by the other, such consent or approval shall not be unreasonably withheld or delayed and the reasons for disapproval of consent shall be stated in reasonable detail in writing. Provisions in this Lease relating to number of days shall be calendar days, unless otherwise specified, provided that if the last day of any period to give notice, reply to a notice or to undertake any other action occurs on a Saturday, Sunday or a bank or City holiday, then the last day for undertaking the action or giving or replying to the notice shall be the next succeeding business day. Use of the word "including" or similar words shall not be construed to limit any general term, statement or other matter in this Lease, whether or not language of non-limitation, such as "without limitation" or similar words, are used.

22.7 Successors and Assigns

Subject to the provisions of Section 14 relating to assignment and subletting, the terms, covenants and conditions contained in this Lease shall bind and inure to the benefit of Landlord and City and, except as otherwise provided herein, their personal representatives and successors and assigns. There are no third-party beneficiaries to this Lease.

22.8 Brokers

Neither party has had any contact or dealings regarding the leasing of the Premises, or any communication in connection therewith, through any licensed real estate broker or other person who could claim a right to a commission or finder's fee in connection with the lease contemplated herein, except for the broker, if any, identified in the Basic Lease Information, whose commission, if any is due, shall be the sole responsibility of Landlord pursuant to a separate written agreement between Landlord and such broker, and City shall have no liability therefor. In the event that any other broker or finder perfects a claim for a commission or finder's fee based upon any such contact, dealings or communication, the party through whom the broker or finder makes his claim shall be responsible for such commission or fee and shall indemnify the other party from any and all Claims incurred by the indemnified party in defending against the same. The provisions of this Section shall survive any termination of this Lease.

22.9 Severability

If any provision of this Lease or the application thereof to any person, entity or circumstance shall, to any extent, be invalid or unenforceable, the remainder of this Lease, or the

application of such provision to persons, entities or circumstances other than those as to which it is invalid or unenforceable, shall not be affected thereby, and each other provision of this Lease shall be valid and be enforceable to the full extent permitted by law, except to the extent that enforcement of this Lease without the invalidated provision would be unreasonable or inequitable under all the circumstances or would frustrate a fundamental purpose of this Lease.

22.10 Governing Law

This Lease shall be construed and enforced in accordance with the laws of the State of California and the City's Charter.

22.11 Entire Agreement

The parties intend that this Lease (including all of the attached exhibits, which are made a part of this Lease) shall be the final expression of their agreement with respect to the subject matter hereof and may not be contradicted by evidence of any prior or contemporaneous written or oral agreements or understandings. The parties further intend that this Lease shall constitute the complete and exclusive statement of its terms and that no extrinsic evidence whatsoever (including prior drafts hereof and changes therefrom) may be introduced in any judicial, administrative or other legal proceeding involving this Lease.

22.12 Attorneys' Fees

In the event that either Landlord or City fails to perform any of its obligations under this Lease or in the event a dispute arises concerning the meaning or interpretation of any provision of this Lease, the defaulting party or the non-prevailing party in such dispute, as the case may be, shall pay the prevailing party reasonable attorneys' and experts' fees and costs, and all court costs and other costs of action incurred by the prevailing party in connection with the prosecution or defense of such action and enforcing or establishing its rights hereunder (whether or not such action is prosecuted to a judgment). For purposes of this Lease, reasonable attorneys' fees of the City's Office of the City Attorney shall be based on the fees regularly charged by private attorneys with the equivalent number of years of experience in the subject matter area of the law for which the City Attorney's services were rendered who practice in the City of San Francisco in law firms with approximately the same number of attorneys as employed by the Office of the City Attorney. The term "attorneys' fees" shall also include, without limitation, all such fees incurred with respect to appeals, mediations, arbitrations, and bankruptcy proceedings, and whether or not any action is brought with respect to the matter for which such fees were incurred. The term "costs" shall mean the costs and expenses of counsel to the parties, which may include printing, duplicating and other expenses, air freight charges, hiring of experts, and fees billed for law clerks, paralegals, and others not admitted to the bar but performing services under the supervision of an attorney.

22.13 Holding Over

Should City hold over without Landlord's consent, such holding over shall not be deemed to extend the Term or renew this Lease, but such tenancy thereafter shall continue as a month-to-month tenancy. Such tenancy shall be on all the terms and conditions set forth in this Lease and at the monthly Base Rent in effect during the last month of the Term of this Lease or such other rental as Landlord and City may mutually agree in writing as a condition to Landlord's consent

to such holding over, and City shall continue as a month-to-month tenant until the tenancy shall be terminated by Landlord giving City or City giving Landlord at least thirty (30) days' prior written notice of termination. Should City hold over without Landlord's consent, the rent payable by City during the period of such holding over shall be at a monthly Base Rent equal to one hundred twenty five percent (125%) of the monthly Base Rent in effect during the last month of the Term of this Lease. Such tenancy shall otherwise be on the terms and conditions contained herein

22.14 Cumulative Remedies

All rights and remedies of either party hereto set forth in this Lease shall be cumulative, except as may otherwise be provided herein.

22.15 Time of Essence

Time is of the essence with respect to all provisions of this Lease in which a definite time for performance is specified.

22.16 Survival of Indemnities

Termination of this Lease shall not affect the right of either party to enforce any and all indemnities and representations and warranties given or made to the other party under this Lease, nor shall it affect any provision of this Lease that expressly states it shall survive termination hereof. Each party hereto specifically acknowledges and agrees that, with respect to each of the indemnities contained in this Lease, the indemnitor has an immediate and independent obligation to defend the indemnitees from any claim which actually or potentially falls within the indemnity provision even if such allegation is or may be groundless, fraudulent or false, which obligation arises at the time such claim is tendered to the indemnitor by the indemnitee and continues at all times thereafter.

22.17 Signs

Subject to all Laws and at City's sole cost, City may erect or post signs on or about the Premises subject to Landlord's prior approval. Landlord reserves the right to review the placement, design, and plan for any such sign prior to its erection or posting and agrees that the approval thereof shall not be unreasonably withheld or delayed. Upon surrender or vacation of the Premises, City shall have removed, at City's sole cost, all signs installed by City and repair, paint, and/or replace any damage to the building facia surface caused by such removal. City shall obtain all applicable governmental permits and approvals for sign and exterior treatments.

22.18 Quiet Enjoyment and Title

Landlord covenants and represents that it has full right, power and authority to grant the leasehold estate hereunder, and covenants that City, upon paying the Rent hereunder and performing the covenants hereof, shall, subject to the terms of this Lease, peaceably and quietly have, hold and enjoy the Premises and all appurtenances during the full Term of this Lease as against all persons or entities claiming by and through Landlord or on account of any action, inaction or agreement of Landlord or its Agents. Without limiting the provisions of Section 16.2 (Landlord's Indemnity), Landlord agrees to Indemnify City and its Agents against Claims arising

out of any breach of Landlord's foregoing representation that would interfere with City's right to quiet enjoyment as provided in this Section.

22.19 Bankruptcy

Landlord represents and warrants to City that Landlord has neither filed nor been the subject of any filing of a petition under the federal bankruptcy law or any federal or state insolvency laws or laws for composition of indebtedness or for the reorganization of debtors, and, to the best of Landlord's knowledge, no such filing is threatened. Landlord and City agree that City's leasehold estate created hereby includes, without limitation, all rights to receive and enjoy all services, facilities and amenities of the Premises and the Buildings as provided herein, and that if due to Landlord's filing of a petition for bankruptcy relief any of such services, facilities or amenities are terminated, or materially limited or restricted on account of any such case or proceeding, [Hazel]City shall have the right to (a) contract directly with any third-party provider of such services, facilities or amenities to obtain the same, and (b) offset against the Base Rent or other charges payable hereunder any and all reasonable costs and expenses incurred by City in obtaining such services, facilities or amenities, provided no such actions violate any rules or requirements of the bankruptcy proceeding.

22.20 Transfer of Landlord's Interest

Landlord shall have the right to transfer its interest in the Premises, Property, the Buildings or this Lease to any other financially responsible person or entity. In the event of any such transfer, Landlord shall be relieved, upon notice to City of the name and address of Landlord's successor, of any obligations accruing hereunder from and after the date of such transfer and upon delivering to City an express assumption by the transferee of all of Landlord's obligations hereunder.

22.21 Non-Liability of City Officials, Employees and Agents

Notwithstanding anything to the contrary in this Lease, no elective or appointive board, commission, member, officer, employee or agent of City shall be personally liable to Landlord, its successors and assigns, in the event of any default or breach by City or for any amount which may become due to Landlord, its successors and assigns, or for any obligation of City under this Lease.

22.22 MacBride Principles - Northern Ireland

The City and County of San Francisco urges companies doing business in Northern Ireland to move toward resolving employment inequities and encourages them to abide by the MacBride Principles as expressed in San Francisco Administrative Code Section 12F.1 et seq. The City and County of San Francisco also urges San Francisco companies to do business with corporations that abide by the MacBride Principles. Landlord acknowledges that it has read and understands the above statement of the City and County of San Francisco concerning doing business in Northern Ireland.

22.23 Controller's Certification of Funds

The terms of this Lease shall be governed by and subject to the budgetary and fiscal provisions of the City's Charter. Notwithstanding anything to the contrary contained in this Lease, there shall be no obligation for the payment or expenditure of money by City under this Lease unless the Controller of the City and County of San Francisco first certifies, pursuant to Section 3.105 of the City's Charter, that there is a valid appropriation from which the expenditure may be made and that unencumbered funds are available from the appropriation to pay the expenditure. Without limiting the foregoing, if in any fiscal year of City after the fiscal year in which the Term of this Lease commences, sufficient funds for the payment of Rent and any other payments required under this Lease are not appropriated, then City may terminate this Lease, without penalty, liability or expense of any kind to City, as of the last date on which sufficient funds are appropriated. City shall use its reasonable efforts to give Landlord reasonable advance notice of such termination.

22.24 Prevailing Wages for Construction Work

Landlord acknowledges that any person performing labor in connection with any Leasehold Improvements or any Alterations at the Premises, including any "public work" as defined under California Labor Code Section 1720 et seq. (which includes certain construction, alteration, demolition, installation, repair, carpet laying, or refuse hauling work) shall be paid not less than the highest prevailing rate of wages consistent with the requirements of Section 6.22(E) of the San Francisco Administrative Code, and shall be subject to the same hours and working conditions, and shall receive the same benefits as in each case are provided for similar work performed in San Francisco County. Landlord shall include in any contract for construction of such Leasehold Improvements and Alterations a requirement that all persons performing labor under such contract shall be paid not less than the highest prevailing rate of wages for the labor so performed. Landlord shall require any contractor to provide, and shall deliver to City upon request, certified payroll reports with respect to all persons performing labor in the construction of improvements to the Premises and such labor to the Premises.

For current Prevailing Wage rates, see www.sfgov.org/olse/prevailingwages or call the City's Office of Labor Standard Enforcement at 415-554-6235.

22.25 Non Discrimination in City Contracts and Benefits Ordinance

(a) Covenant Not to Discriminate

In the performance of this Lease, Landlord agrees not to discriminate against any employee of, any City employee working with Landlord, or applicant for employment with Landlord, or against any person seeking accommodations, advantages, facilities, privileges, services, or membership in all business, social, or other establishments or organizations, on the basis of the fact or perception of a person's race, color, creed, religion, national origin, ancestry, age, height, weight, sex, sexual orientation, gender identity, domestic partner status, marital status, disability or Acquired Immune Deficiency Syndrome or HIV status (AIDS/HIV status), or association with members of such protected classes, or in retaliation for opposition to discrimination against such classes.

(b) Subcontracts

Landlord shall include in all subcontracts relating to the Premises a non-discrimination clause applicable to such subcontractor in substantially the form of subsection (a) above. In addition, Landlord shall incorporate by reference in all subcontracts the provisions of Sections 12B.2(a), 12B.2(c)-(k) and 12C.3 of the San Francisco Administrative Code and shall require all subcontractors to comply with such provisions. Landlord's failure to comply with the obligations in this subsection shall constitute a material breach of this Lease.

(c) Non-Discrimination in Benefits

Landlord does not as of the date of this Lease and will not during the term of this Lease, in any of its operations in San Francisco, on real property owned by City, or where the work is being performed for the City or elsewhere within the United States, discriminate in the provision of bereavement leave, family medical leave, health benefits, membership or membership discounts, moving expenses, pension and retirement benefits or travel benefits, as well as any benefits other than the benefits specified above, between employees with domestic partners and employees with spouses, and/or between the domestic partners and spouses of such employees, where the domestic partnership has been registered with a governmental entity pursuant to state or local law authorizing such registration, subject to the conditions set forth in Section 12B.2(b) of the San Francisco Administrative Code.

(d) CMD Form

As a condition to this Lease, Landlord shall execute the "Chapter 12B Declaration: Nondiscrimination in Contracts and Benefits" form (Form CMD-12B-101) with supporting documentation and secure the approval of the form by the San Francisco Contract Monitoring Division (formerly known as the San Francisco Human Rights Commission) ("CMD"). Landlord hereby represents that prior to execution of this Lease, (i) Landlord executed and submitted to the CMD Form CMD-12B-101 with supporting documentation, and (ii) the CMD approved such form.

(e) Incorporation of Administrative Code Provisions by Reference

The provisions of Chapters 12B and 12C of the San Francisco Administrative Code relating to non-discrimination by parties contracting for the lease of property to City are incorporated in this Section by reference and made a part of this Lease as though fully set forth herein. Landlord shall comply fully with and be bound by all of the provisions that apply to this Lease under such Chapters of the Administrative Code, including but not limited to the remedies provided in such Chapters. Without limiting the foregoing, Landlord understands that pursuant to Section 12B.2(h) of the San Francisco Administrative Code, a penalty of Fifty Dollars (\$50) for each person for each calendar day during which such person was discriminated against in violation of the provisions of this Lease may be assessed against Landlord and/or deducted from any payments due Landlord.

22.26 Tropical Hardwood and Virgin Redwood Ban

(a) Except as expressly permitted by the application of Sections 802(b) and 803(b) of the San Francisco Environment Code, neither Landlord nor any of its contractors shall provide any items to City in the construction of the Leasehold Improvements or otherwise in the performance of this Lease which are tropical hardwood, tropical hardwood wood products, virgin redwood, or virgin redwood wood products.

(b) The City and County of San Francisco urges companies not to import, purchase, obtain or use for any purpose, any tropical hardwood, tropical hardwood wood product, virgin redwood, or virgin redwood wood products.

(c) In the event Landlord fails to comply in good faith with any of the provisions of Chapter 8 of the San Francisco Environment Code, Landlord shall be liable for liquidated damages for each violation in an amount equal to Landlord's net profit on the contract, or five percent (5%) of the total amount of the contract dollars, whichever is greatest. Landlord acknowledges and agrees that the liquidated damages assessed shall be payable to the City and County of San Francisco upon demand and may be set off against any monies due to Landlord from any contract with the City and County of San Francisco.

22.27 Bicycle Parking Facilities

Article 1.5, Section 155.3, of the San Francisco Planning Code (the "Planning Code") requires the provision of bicycle parking at City-leased buildings at no cost to Landlord. Provided there is no interference with parking or access for other tenants of the Property, during the Term, City shall have the right to install and maintain, at its sole cost, all Class 1 Bicycle Parking Spaces (as defined in the Planning Code) and all Class 2 Bicycle Parking Spaces (as defined in the Planning Code) in the Building locations required under the Planning Code.

22.28 Resource-Efficient City Buildings and Pilot Projects

Landlord acknowledges that the City and County of San Francisco has enacted San Francisco Environment Code Sections 700 to 713 relating to green building requirements for the design, construction and operation of City buildings. Landlord hereby agrees that it shall comply with all applicable provisions of such code sections.

22.29 Counterparts

This Lease may be executed in two or more counterparts, each of which shall be deemed an original, but all of which taken together shall constitute one and the same instrument.

22.30 Effective Date; Conditions Precedent to Effectiveness of Lease

The date on which this Lease shall become effective (the "Effective Date") is the later date upon which: (a) City's Mayor and Board of Supervisors, in their sole and absolute discretion, adopt a resolution approving this Lease in accordance with all applicable laws, including but not limited to the California Environmental Quality Act (CEQA), and any and all conditions set forth in the authorizing resolution have been satisfied; (b) this Lease is duly

executed by the parties hereto; and (c) all Conditions Precedent (as described in Section 3.6 above) have been satisfied to City's satisfaction, in its sole discretion.

22.31 Sunshine Ordinance

In accordance with Section 67.24(e) of the San Francisco Administrative Code, contracts, contractors' bids, leases, agreements, responses to Requests for Proposals, and all other records of communications between City and persons or firms seeking contracts will be open to inspection immediately after a contract has been awarded. Nothing in this provision requires the disclosure of a private person's or organization's net worth or other proprietary financial data submitted for qualification for a contract, lease, agreement or other benefit until and unless that person or organization is awarded the contract, lease, agreement or benefit. Information provided which is covered by this Section will be made available to the public upon request.

22.32 Conflicts of Interest

Through its execution of this Lease, Landlord acknowledges that it is familiar with the provisions of Section 15.103 of the San Francisco Charter, Article III, Chapter 2 of City's Campaign and Governmental Conduct Code, and Section 87100 et seq. and Section 1090 et seq. of the Government Code of the State of California, and certifies that it does not know of any facts which would constitute a violation of said provisions, and agrees that if Landlord becomes aware of any such fact during the Term of this Lease, Landlord shall immediately notify City.

22.33 Notification of Limitations on Contributions

Through its execution of this Lease, Landlord acknowledges that it is familiar with Section 1.126 of the San Francisco Campaign and Governmental Conduct Code, which prohibits any person who contracts with the City for the selling or leasing of any land or building to or from the City whenever such transaction would require approval by a City elective officer, the board on which that City elective officer serves, or a board on which an appointee of that individual serves, from making any campaign contribution to (a) the City elective officer, (b) a candidate for the office held by such individual, or (c) a committee controlled by such individual or candidate, at any time from the commencement of negotiations for the contract until the later of either the termination of negotiations for such contract or six months after the date the contract is approved. Landlord acknowledges that the foregoing restriction applies only if the contract or a combination or series of contracts approved by the same individual or board in a fiscal year have a total anticipated or actual value of \$50,000 or more. Landlord further acknowledges that the prohibition on contributions applies to each Landlord; each member of Landlord's board of directors, and Landlord's chief executive officer, chief financial officer and chief operating officer; any person with an ownership interest of more than 20 percent in Landlord; any subcontractor listed in the contract; and any committee that is sponsored or controlled by Landlord. Additionally, Landlord acknowledges that Landlord must inform each of the persons described in the preceding sentence of the prohibitions contained in Section 1.126. Landlord further agrees to provide to City the name of each person, entity or committee described above.

22.34 Preservative-Treated Wood Containing Arsenic

As of July 1, 2003, Landlord may not purchase preservative-treated wood products containing arsenic in the performance of this Lease unless an exemption from the requirements of Environment Code, Chapter 13 is obtained from the Department of Environment under Section 1304 of the Environment Code. The term "preservative-treated wood containing arsenic" shall mean wood treated with a preservative that contains arsenic, elemental arsenic, or an arsenic copper combination, including, but not limited to, chromated copper arsenate preservative, ammoniac copper zinc arsenate preservative, or ammoniacal copper arsenate preservative. Landlord may purchase preservative-treated wood products on the list of environmentally preferable alternatives prepared and adopted by the Department of Environment. This provision does not preclude Landlord from purchasing preservative-treated wood containing arsenic for saltwater immersion. The term "saltwater immersion" shall mean a pressure-treated wood that is used for construction purposes or facilities that are partially or totally immersed in saltwater.

22.35 Cooperative Drafting

This Lease has been drafted through a cooperative effort of both parties, and both parties have had an opportunity to have the Lease reviewed and revised by legal counsel. No party shall be considered the drafter of this Lease, and no presumption or rule that an ambiguity shall be construed against the party drafting the clause shall apply to the interpretation or enforcement of this Lease.

NOTWITHSTANDING ANYTHING TO THE CONTRARY CONTAINED IN THIS LEASE, LANDLORD ACKNOWLEDGES AND AGREES THAT NO OFFICER OR EMPLOYEE OF CITY HAS AUTHORITY TO COMMIT CITY HERETO UNLESS AND UNTIL CITY'S BOARD OF SUPERVISORS SHALL HAVE DULY ADOPTED A RESOLUTION APPROVING THIS LEASE AND AUTHORIZING CONSUMMATION OF THE TRANSACTION CONTEMPLATED HEREBY. THEREFORE, ANY OBLIGATIONS OR LIABILITIES OF CITY HEREUNDER ARE CONTINGENT UPON ADOPTION OF SUCH A RESOLUTION, AND THIS LEASE SHALL BE NULL AND VOID UNLESS CITY'S MAYOR AND BOARD OF SUPERVISORS APPROVE THIS LEASE, IN THEIR RESPECTIVE SOLE AND ABSOLUTE DISCRETION, AND IN ACCORDANCE WITH ALL APPLICABLE LAWS. APPROVAL OF THIS LEASE BY ANY DEPARTMENT, COMMISSION OR AGENCY OF CITY SHALL NOT BE DEEMED TO IMPLY THAT SUCH RESOLUTION WILL BE ADOPTED NOR WILL ANY SUCH APPROVAL CREATE ANY BINDING OBLIGATIONS ON CITY.

Landlord and City have executed this Lease as of the date first written above.

LANDLORD:

W.Y.L. Orion Properties, LLC
a California Limited Liability Corporation

By: 

James Lew

Title: CFO

CITY:

CITY AND COUNTY OF SAN FRANCISCO,
a municipal corporation

By: 

JOHN UPDIKE

Director of Property

APPROVED AS TO FORM:

DENNIS J. HERRERA, City Attorney

By: 

Eileen Chauvet

Deputy City Attorney

EXHIBIT A

SITE PLAN(S)

CONSISTING OF ____ PAGE(S)

Exhibit A

125 BAYSHORE BLVD.
NAVIGATION CENTER
MEI ARCHITECTS

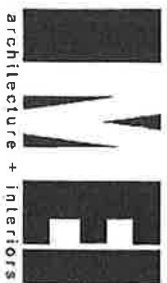

BUILDING PERMIT SUBMITTAL
30 MARCH, 2018



EXTERIOR

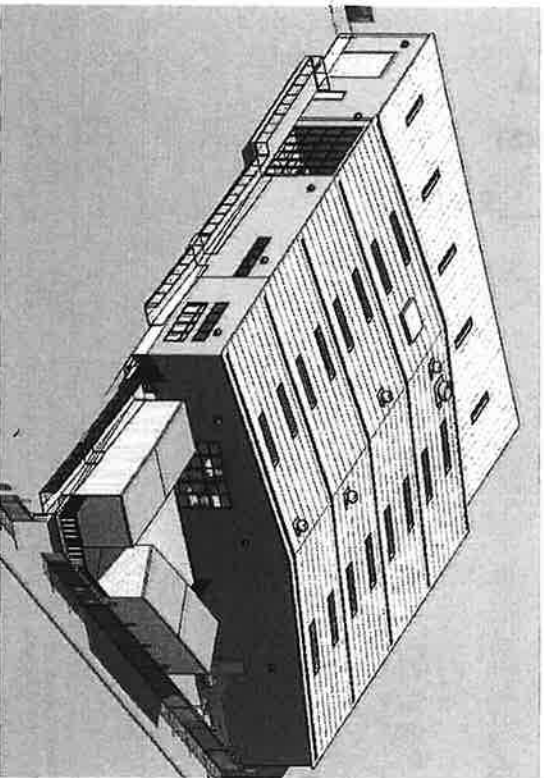

CONTEXT



PROJECT SITE





M/E
 ARCHITECTS
 2000 CALIFORNIA STREET, SUITE 1100
 SAN FRANCISCO, CALIFORNIA 94133
 415.774.3130

125 BAYSHORE BLVD.
 NAVIGATION CENTER
 San Francisco Department of Public Works
 1100 MARKET STREET, SUITE 1000
 SAN FRANCISCO, CALIFORNIA 94102

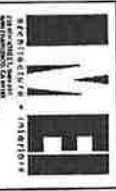

CONSULTANTS

GENERAL CONTRACTOR: **BRUCE**
 3330 VAN NESS AVENUE, SUITE 200
 SAN FRANCISCO, CALIFORNIA 94134

GENERAL CONTRACTOR: **JOHN J. KYLE & ASSOCIATES**
 3000 CALIFORNIA STREET, SUITE 1100
 SAN FRANCISCO, CALIFORNIA 94133

PROJECT DATA, ABBREVIATIONS, SYMBOLS, DRAWING INDEX

PROJECT NO.: **02-0001**

DATE: **02/15/2011**

DESIGNED BY: **CE/FIELD BFR**

DRAWN BY: **CE/FIELD BFR**

CHECKED AND IN CHARGE: **CE/FIELD BFR**

SHEET NO.: **10**

TOTAL SHEETS: **10**

PROJECT: **BAYSHORE BLVD.**

DRAWING INDEX

NO.	DESCRIPTION	DATE
1	EXISTING CONDITION DRAWING	02/15/2011
2	EXISTING CONDITIONS	02/15/2011
3	EXISTING CONDITIONS	02/15/2011
4	EXISTING CONDITIONS	02/15/2011
5	EXISTING CONDITIONS	02/15/2011
6	EXISTING CONDITIONS	02/15/2011
7	EXISTING CONDITIONS	02/15/2011
8	EXISTING CONDITIONS	02/15/2011
9	EXISTING CONDITIONS	02/15/2011
10	EXISTING CONDITIONS	02/15/2011

EXISTING BUILDING DATA

NO.	DESCRIPTION
1	EXISTING BUILDING DATA
2	EXISTING BUILDING DATA
3	EXISTING BUILDING DATA
4	EXISTING BUILDING DATA
5	EXISTING BUILDING DATA
6	EXISTING BUILDING DATA
7	EXISTING BUILDING DATA
8	EXISTING BUILDING DATA
9	EXISTING BUILDING DATA
10	EXISTING BUILDING DATA

PROPOSED BUILDING DATA

NO.	DESCRIPTION
1	PROPOSED BUILDING DATA
2	PROPOSED BUILDING DATA
3	PROPOSED BUILDING DATA
4	PROPOSED BUILDING DATA
5	PROPOSED BUILDING DATA
6	PROPOSED BUILDING DATA
7	PROPOSED BUILDING DATA
8	PROPOSED BUILDING DATA
9	PROPOSED BUILDING DATA
10	PROPOSED BUILDING DATA

PROJECT TEAM

ARCHITECT

M/E ARCHITECTS
 2000 CALIFORNIA STREET, SUITE 1100
 SAN FRANCISCO, CALIFORNIA 94133
 415.774.3130

ELECTRICAL

DAVID L. MURPHY
 2000 CALIFORNIA STREET, SUITE 1100
 SAN FRANCISCO, CALIFORNIA 94133
 415.774.3130

GENERAL NOTES

- ALL WORK SHALL BE IN ACCORDANCE WITH THE CITY OF SAN FRANCISCO DEPARTMENT OF PUBLIC WORKS SPECIFICATIONS AND STANDARDS.
- CONTRACTOR SHALL BE RESPONSIBLE FOR OBTAINING ALL NECESSARY PERMITS AND APPROVALS.
- ALL MATERIALS AND METHODS OF CONSTRUCTION SHALL BE APPROVED BY THE CITY ENGINEER.
- ALL WORK SHALL BE COMPLETED WITHIN THE SPECIFIED TIME FRAME.
- CONTRACTOR SHALL MAINTAIN ACCESS TO ALL ADJACENT PROPERTIES AND UTILITIES.
- ALL WORK SHALL BE COMPLETED IN ACCORDANCE WITH THE CITY ENGINEER'S REQUIREMENTS.
- ALL WORK SHALL BE COMPLETED IN ACCORDANCE WITH THE CITY ENGINEER'S REQUIREMENTS.
- ALL WORK SHALL BE COMPLETED IN ACCORDANCE WITH THE CITY ENGINEER'S REQUIREMENTS.
- ALL WORK SHALL BE COMPLETED IN ACCORDANCE WITH THE CITY ENGINEER'S REQUIREMENTS.
- ALL WORK SHALL BE COMPLETED IN ACCORDANCE WITH THE CITY ENGINEER'S REQUIREMENTS.

ABBREVIATIONS

NO.	DESCRIPTION
1	ABBREVIATIONS
2	ABBREVIATIONS
3	ABBREVIATIONS
4	ABBREVIATIONS
5	ABBREVIATIONS
6	ABBREVIATIONS
7	ABBREVIATIONS
8	ABBREVIATIONS
9	ABBREVIATIONS
10	ABBREVIATIONS

APPLICABLE CODES AND STANDARDS

NO.	DESCRIPTION
1	APPLICABLE CODES AND STANDARDS
2	APPLICABLE CODES AND STANDARDS
3	APPLICABLE CODES AND STANDARDS
4	APPLICABLE CODES AND STANDARDS
5	APPLICABLE CODES AND STANDARDS
6	APPLICABLE CODES AND STANDARDS
7	APPLICABLE CODES AND STANDARDS
8	APPLICABLE CODES AND STANDARDS
9	APPLICABLE CODES AND STANDARDS
10	APPLICABLE CODES AND STANDARDS

SYMBOLS

NO.	DESCRIPTION
1	SYMBOLS
2	SYMBOLS
3	SYMBOLS
4	SYMBOLS
5	SYMBOLS
6	SYMBOLS
7	SYMBOLS
8	SYMBOLS
9	SYMBOLS
10	SYMBOLS

MATERIALS

NO.	DESCRIPTION
1	MATERIALS
2	MATERIALS
3	MATERIALS
4	MATERIALS
5	MATERIALS
6	MATERIALS
7	MATERIALS
8	MATERIALS
9	MATERIALS
10	MATERIALS

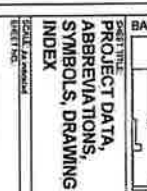

G0-2

PROJECT: **BAYSHORE BLVD.**

DATE: **02/15/2011**

DESIGNED BY: **CE/FIELD BFR**

DRAWN BY: **CE/FIELD BFR**

CHECKED AND IN CHARGE: **CE/FIELD BFR**

SHEET NO.: **10**

TOTAL SHEETS: **10**

OCCUPANT LOAD CALCULATION	
ROOM NAME	AREA
OFFICE	100 SF
CONFERENCE ROOM	100 SF
RESTROOM	50 SF
STORAGE	200 SF
TOTAL	450 SF

EXITING OFFICE BLDG. OCCUPANCY
 FIRST FLOOR AREA, 3000 SQ FT - 600 OCCUPANTS
 SECOND FLOOR AREA, 4500 SQ FT - 900 OCCUPANTS

EXITING CALCULATIONS
 3000 SQ FT WITH 600 OCCUPANTS = 2.00 SQ FT/OCCUPANT
 4500 SQ FT WITH 900 OCCUPANTS = 5.00 SQ FT/OCCUPANT

LEGEND

- 1-HOUR FIRE RATED AND SMOKE PARTITION
- PARTIAL EGRESS
- EXIT OCCUPANT LOAD
- F.S.L.
- FIRE DETECTOR/SMoke DETECTOR
- NOTE: ALL FIRE TYPE IS 2A/80/0 PER NFPA 720.1.1

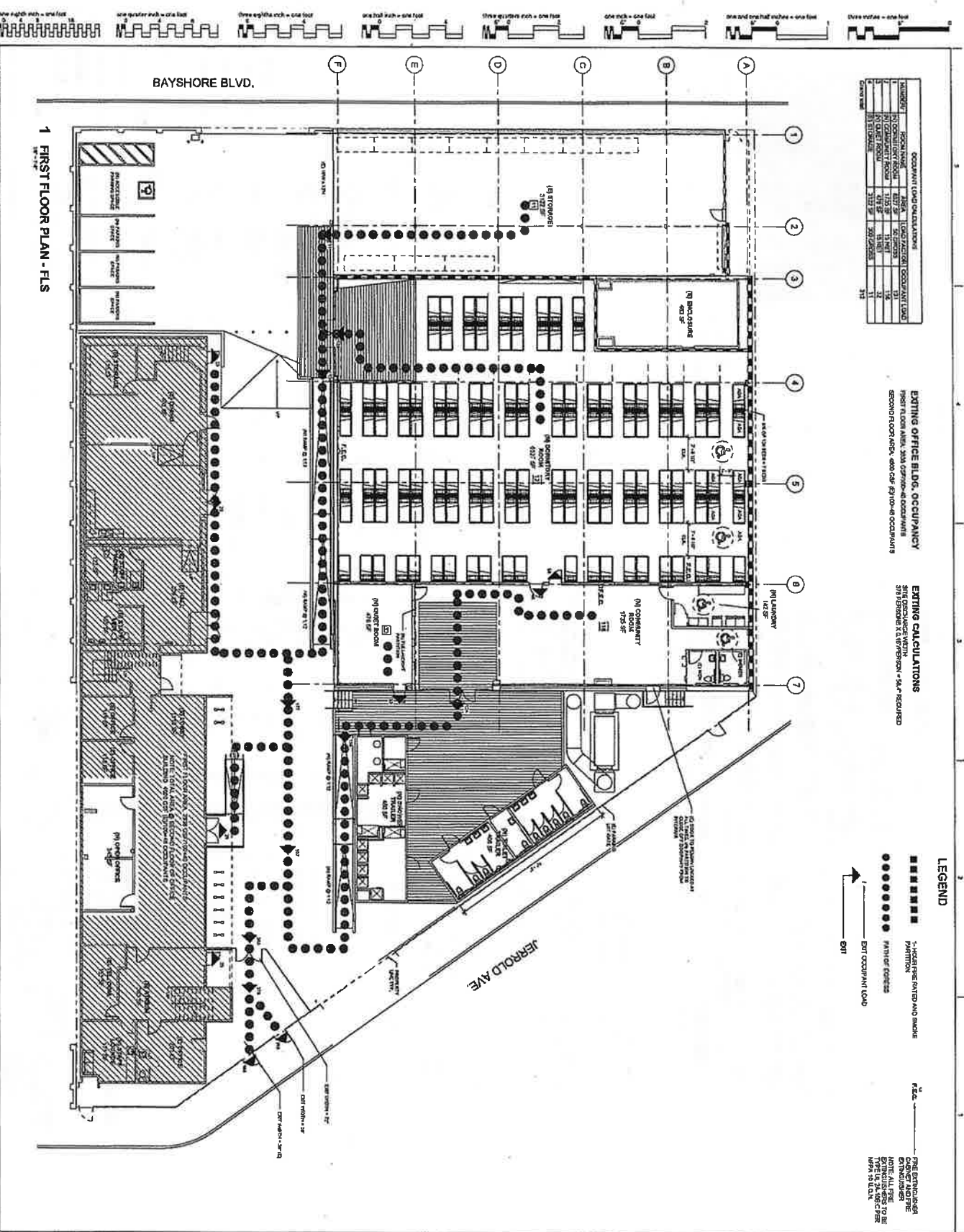

1 FIRST FLOOR PLAN - FLS

125 BAYSHORE BLVD.
NAVIGATION CENTER

San Francisco Department of
 Public Works
 DISTRICT PROJECT NO. 2000

PROJECT TITLE:
FIRE LIFE SAFETY AND EGRESS PLAN

PROJECT NO.: 2000-0000-0000

DATE: 11/15/00

PROJECTED TO: 11/15/00

DESIGNED BY: [Name]

CHECKED BY: [Name]

SCALE: As Shown

PROJECT NO.: 2000-0000-0000

DATE: 11/15/00

PROJECTED TO: 11/15/00

DESIGNED BY: [Name]

CHECKED BY: [Name]

SCALE: As Shown

GO-3

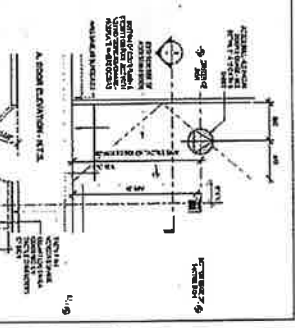
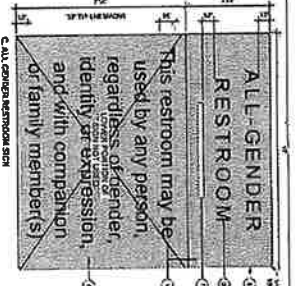
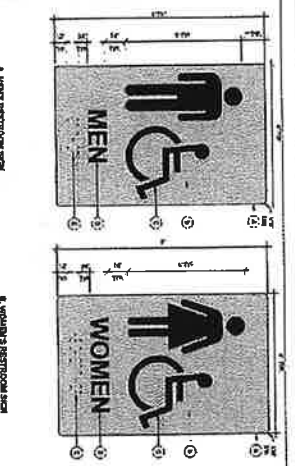
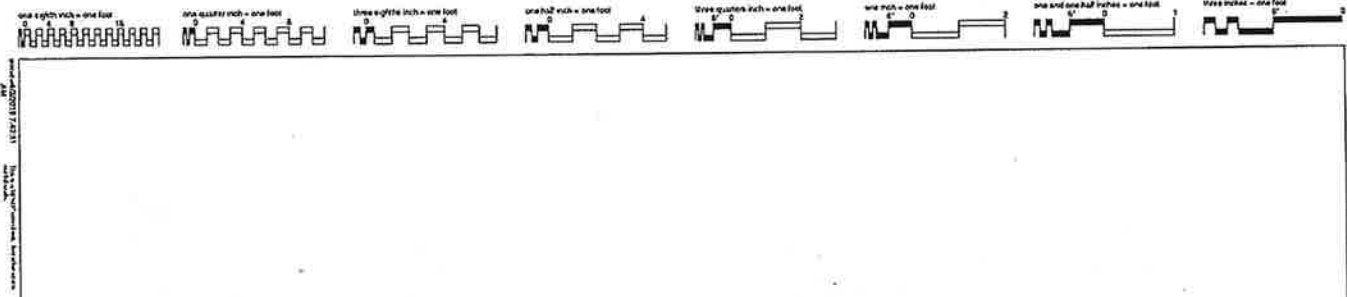

- RESTROOM SIGNAGE NOTES**
1. SIGNAGE SHALL BE MOUNTED ON THE DOOR OR WALL IN THE RESTROOM.
 2. SIGNAGE SHALL BE MOUNTED AT A HEIGHT OF 5' 0" TO 5' 6" FROM THE FINISHED FLOOR TO THE CENTER OF THE SIGN.
 3. SIGNAGE SHALL BE MOUNTED ON A WALL OR DOOR THAT IS AT LEAST 3' 0" WIDE AND 6' 0" HIGH.
 4. SIGNAGE SHALL BE MOUNTED ON A WALL OR DOOR THAT IS AT LEAST 3' 0" WIDE AND 6' 0" HIGH.
 5. SIGNAGE SHALL BE MOUNTED ON A WALL OR DOOR THAT IS AT LEAST 3' 0" WIDE AND 6' 0" HIGH.
 6. SIGNAGE SHALL BE MOUNTED ON A WALL OR DOOR THAT IS AT LEAST 3' 0" WIDE AND 6' 0" HIGH.
 7. SIGNAGE SHALL BE MOUNTED ON A WALL OR DOOR THAT IS AT LEAST 3' 0" WIDE AND 6' 0" HIGH.
 8. SIGNAGE SHALL BE MOUNTED ON A WALL OR DOOR THAT IS AT LEAST 3' 0" WIDE AND 6' 0" HIGH.
 9. SIGNAGE SHALL BE MOUNTED ON A WALL OR DOOR THAT IS AT LEAST 3' 0" WIDE AND 6' 0" HIGH.
 10. SIGNAGE SHALL BE MOUNTED ON A WALL OR DOOR THAT IS AT LEAST 3' 0" WIDE AND 6' 0" HIGH.
 11. SIGNAGE SHALL BE MOUNTED ON A WALL OR DOOR THAT IS AT LEAST 3' 0" WIDE AND 6' 0" HIGH.
 12. SIGNAGE SHALL BE MOUNTED ON A WALL OR DOOR THAT IS AT LEAST 3' 0" WIDE AND 6' 0" HIGH.
 13. SIGNAGE SHALL BE MOUNTED ON A WALL OR DOOR THAT IS AT LEAST 3' 0" WIDE AND 6' 0" HIGH.

- 1. SIGN NOTICES ON LIGHT COLORED DOORS**
1. SIGN NOTICES SHALL BE MOUNTED ON THE DOOR OR WALL IN THE RESTROOM.
 2. SIGNAGE SHALL BE MOUNTED AT A HEIGHT OF 5' 0" TO 5' 6" FROM THE FINISHED FLOOR TO THE CENTER OF THE SIGN.
 3. SIGNAGE SHALL BE MOUNTED ON A WALL OR DOOR THAT IS AT LEAST 3' 0" WIDE AND 6' 0" HIGH.
 4. SIGNAGE SHALL BE MOUNTED ON A WALL OR DOOR THAT IS AT LEAST 3' 0" WIDE AND 6' 0" HIGH.
 5. SIGNAGE SHALL BE MOUNTED ON A WALL OR DOOR THAT IS AT LEAST 3' 0" WIDE AND 6' 0" HIGH.
 6. SIGNAGE SHALL BE MOUNTED ON A WALL OR DOOR THAT IS AT LEAST 3' 0" WIDE AND 6' 0" HIGH.
 7. SIGNAGE SHALL BE MOUNTED ON A WALL OR DOOR THAT IS AT LEAST 3' 0" WIDE AND 6' 0" HIGH.
 8. SIGNAGE SHALL BE MOUNTED ON A WALL OR DOOR THAT IS AT LEAST 3' 0" WIDE AND 6' 0" HIGH.
 9. SIGNAGE SHALL BE MOUNTED ON A WALL OR DOOR THAT IS AT LEAST 3' 0" WIDE AND 6' 0" HIGH.
 10. SIGNAGE SHALL BE MOUNTED ON A WALL OR DOOR THAT IS AT LEAST 3' 0" WIDE AND 6' 0" HIGH.
 11. SIGNAGE SHALL BE MOUNTED ON A WALL OR DOOR THAT IS AT LEAST 3' 0" WIDE AND 6' 0" HIGH.
 12. SIGNAGE SHALL BE MOUNTED ON A WALL OR DOOR THAT IS AT LEAST 3' 0" WIDE AND 6' 0" HIGH.
 13. SIGNAGE SHALL BE MOUNTED ON A WALL OR DOOR THAT IS AT LEAST 3' 0" WIDE AND 6' 0" HIGH.

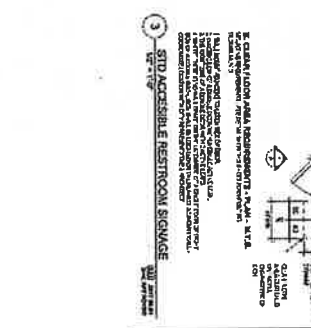
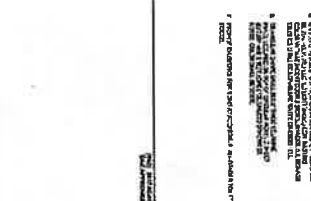
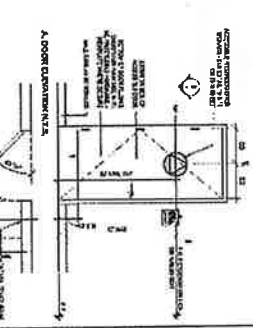

WE ARCHITECTURE + INTERIORS
125 BAYSHORE BLVD. NAVIGATION CENTER
San Francisco Department of Public Works
CONTRACT NO. 2018-01-0000

PROJECT TITLE: BAYSHORE BLVD. DPW STANDARD SIGNAGE DETAILS

PROJECT NO.: 00-0000

DATE: 01/01/2018

REVISIONS:

NO.	DESCRIPTION	DATE
1	ISSUE FOR BIDDING (REVISED)	01/01/2018
2	ISSUE FOR BIDDING (REVISED)	01/01/2018

CLIENT: BAYSHORE BLVD. DPW STANDARD SIGNAGE DETAILS

ARCHITECT: WE ARCHITECTURE + INTERIORS

SCALE: AS SHOWN

PROJECT NO.: 00-0000

DATE: 01/01/2018

REVISIONS:

13

PROJECT TITLE: BAYSHORE BLVD. DPW STANDARD SIGNAGE DETAILS

PROJECT NO.: 00-0000

DATE: 01/01/2018

REVISIONS:

13



3117
FOUR
PROVISIONS

DISABILITY ACCESS COMPLIANCE FOR CITY FUNDED PROJECTS
Application for Accessible and Addressed Buildings Act, Title III of the Americans with Disabilities Act (ADA)
125 Bayshore Blvd, Navigation Center
325 Bayshore Blvd, San Francisco, CA
125 Bayshore Blvd - San Francisco Department of Public Works
125 Bayshore Blvd - Navigation Center and Construction Division
125 Bayshore Blvd - Navigation Center
125 Bayshore Blvd - Navigation Center and Construction Division
125 Bayshore Blvd - Navigation Center and Construction Division

WHEN DOES BDC DAC DO A PLAN CHECK AND INSPECTION?
Project Phase of Activity

Activity	Unit	Frequency	Always	Preferred	As-Needed
Arch. Review Construction	Unit	Always	Always	Preferred	As-Needed
Concept Consultation	Unit	Yes	Preferred	Preferred	As-Needed
Concept Review	Unit	Yes	Preferred	As-Needed	As-Needed
Design Development Plan Check 30%	Unit	Yes	Preferred	As-Needed	As-Needed
SUBMITTAL CHECK 50%	Unit	Yes	Preferred	As-Needed	As-Needed
Construction Documents Plan Check 90-95%	Unit	Yes	Preferred	As-Needed	As-Needed
DAC Approval Letter and BDC DAC Form for File	Unit	Yes	Preferred	As-Needed	As-Needed
Final Plan Check Stamp and Approval	Unit	Yes	Preferred	As-Needed	As-Needed
Final Construction Consultation	Unit	Yes	Preferred	As-Needed	As-Needed
Rough-In Inspections	Unit	Yes	Preferred	As-Needed	As-Needed
Multiple Interim Inspections	Unit	Yes	Preferred	As-Needed	As-Needed
Final Inspection	Unit	Yes	Preferred	As-Needed	As-Needed
Final Inspection	Unit	Yes	Preferred	As-Needed	As-Needed
Final Inspection	Unit	Yes	Preferred	As-Needed	As-Needed

PLAN CHECK AND INSPECTION

Activity	Unit	Frequency	Always	Preferred	As-Needed
Arch. Review Construction	Unit	Always	Always	Preferred	As-Needed
Concept Consultation	Unit	Yes	Preferred	Preferred	As-Needed
Concept Review	Unit	Yes	Preferred	As-Needed	As-Needed
Design Development Plan Check 30%	Unit	Yes	Preferred	As-Needed	As-Needed
SUBMITTAL CHECK 50%	Unit	Yes	Preferred	As-Needed	As-Needed
Construction Documents Plan Check 90-95%	Unit	Yes	Preferred	As-Needed	As-Needed
DAC Approval Letter and BDC DAC Form for File	Unit	Yes	Preferred	As-Needed	As-Needed
Final Plan Check Stamp and Approval	Unit	Yes	Preferred	As-Needed	As-Needed
Final Construction Consultation	Unit	Yes	Preferred	As-Needed	As-Needed
Rough-In Inspections	Unit	Yes	Preferred	As-Needed	As-Needed
Multiple Interim Inspections	Unit	Yes	Preferred	As-Needed	As-Needed
Final Inspection	Unit	Yes	Preferred	As-Needed	As-Needed
Final Inspection	Unit	Yes	Preferred	As-Needed	As-Needed
Final Inspection	Unit	Yes	Preferred	As-Needed	As-Needed



125 BAYSHORE BLVD, NAVIGATION CENTER
San Francisco Department of Public Works
125 BAYSHORE BLVD, NAVIGATION CENTER
SAN FRANCISCO, CA 94133



CONSULTANT

GO-5

DISABILITY ACCESS COMPLIANCE
FORMS



PROJECT: BAYSHORE BLVD, NAVIGATION CENTER
PROJECT NO: [blank]
DATE: [blank]
DRAWING NO: [blank]
REVISIONS: [blank]

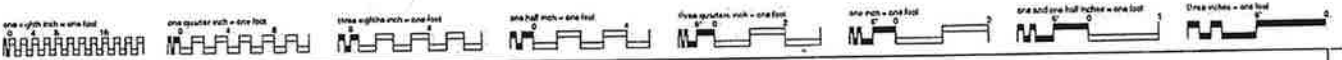

DEALER
PHOENIX
PROJECT
HOMELSS PBLIC RESTROOMS
12' X 40'
PM-5580-240

PHOENIX MODULAR
 A Division of
SURREY MODULAR, INC.

1 5

PHOENIX MODULAR
 A Division of
SURREY MODULAR, INC.

2 5

PHOENIX MODULAR
 A Division of
SURREY MODULAR, INC.

3 5

PHOENIX MODULAR
 A Division of
SURREY MODULAR, INC.

4 5

W E I

125 BAYSHORE BLVD
 NAVIGATION CENTER
 San Francisco Department of
 Public Works
 BIRMINGHAM, AL 35203
 PHOENIX PROJECT No. 0000

125 BAYSHORE BLVD.

MODULAR RESTROOM TRAILER (FOR REFERENCE ONLY)

G1-0

RECORD DATE

NO. DATE DESCRIPTION

PROJECT NO.

PROJECT NAME

OWNER

DESIGNED BY

CHECKED BY

DATE

SCALE

THE COMPANY HAS THE RIGHT TO REPRODUCE THIS DRAWING FOR THE PROJECT AND TO MAKE ANY NECESSARY CHANGES TO IT WITHOUT NOTICE TO THE ARCHITECT.

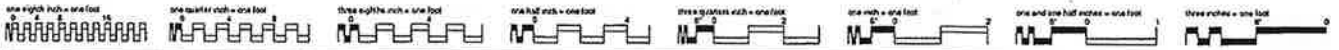

DRAWING NO. 10-0117 10-15
 DATE: 10/15/01
 SHEET NO. 1 OF 1

1. GENERAL SHOWER PLAN

2. SECTION A-A

3. FINISHED GROUND SECTION

4. MATERIAL SCHEDULE

NO.	DESCRIPTION	QUANTITY	UNIT
1
2
3
4
5
6

PHOENIX MODULAR
 A Division of
SUNBELT MODULAR, INC.

ELEVATION 'B'

ELEVATION 'C'

ELEVATION 'A'

ELEVATION 'D'

PHOENIX MODULAR
 A Division of
SUNBELT MODULAR, INC.

PHOENIX MODULAR
 A Division of
SUNBELT MODULAR, INC.

DEALER
 PROJECT
 HONGKONG SELLER OWNERS
 H X A
 PH-8929440

1. GENERAL SHOWER PLAN

2. SECTION A-A

3. FINISHED GROUND SECTION

4. MATERIAL SCHEDULE

NO.	DESCRIPTION	QUANTITY	UNIT
1
2
3
4
5
6

1. GENERAL SHOWER PLAN

2. SECTION A-A

3. FINISHED GROUND SECTION

4. MATERIAL SCHEDULE

NO.	DESCRIPTION	QUANTITY	UNIT
1
2
3
4
5
6

PHOENIX MODULAR
 A Division of
SUNBELT MODULAR, INC.

125 BAYSHORE BLVD.
NAVIGATION CENTER

San Francisco Department of
 Public Works
 Engineering Division
 1401 Market Street, Room 1201
 San Francisco, CA 94102

M E I

2000 LITTLE BLVD. #100
 SAN FRANCISCO, CA 94102-3078
 TEL: (415) 441-1100
 FAX: (415) 441-1101
 WWW.MEI-CORP.COM

PHOENIX MODULAR
 A Division of
SUNBELT MODULAR, INC.

SCALE: 1/4" = 1'-0"

G-11

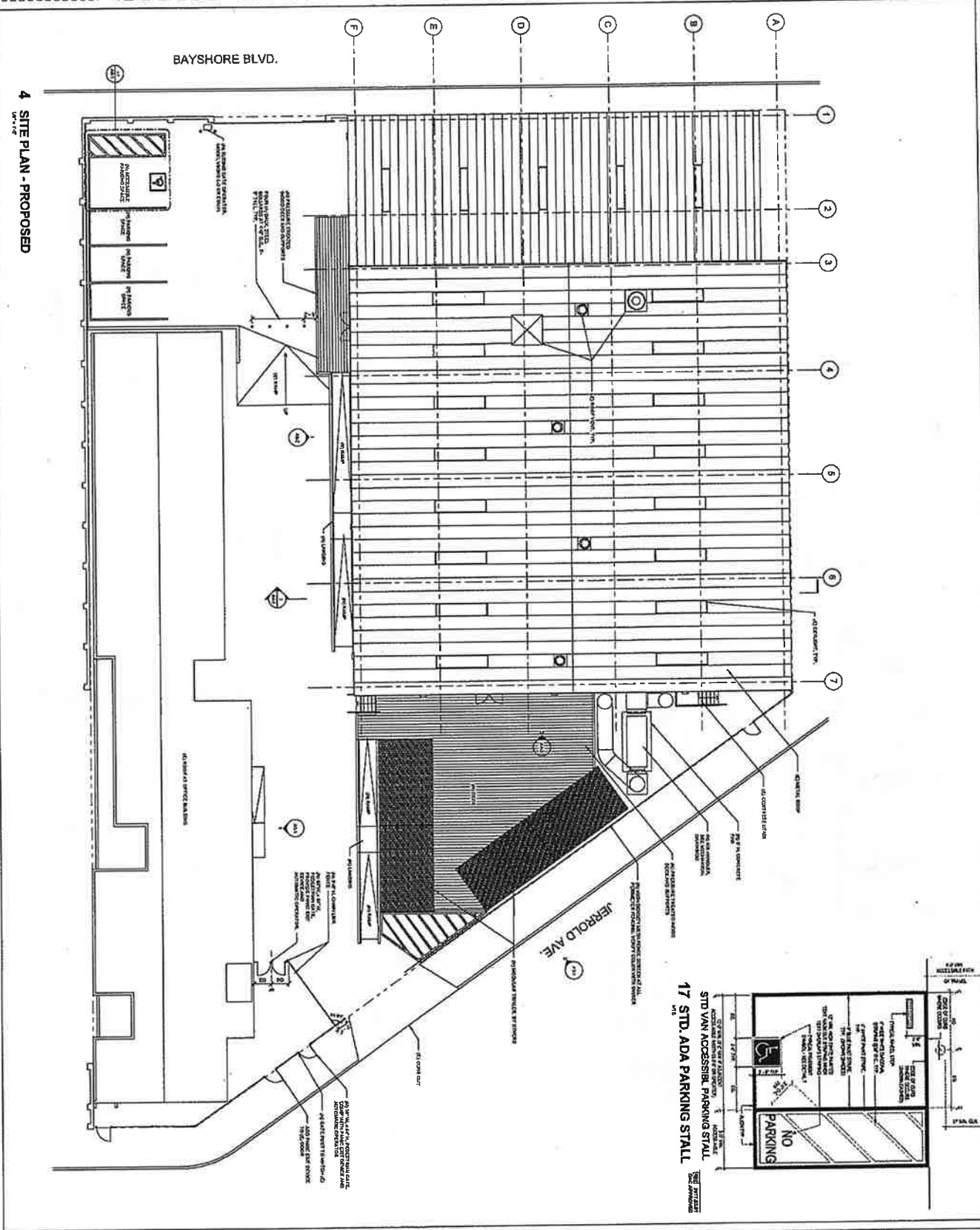
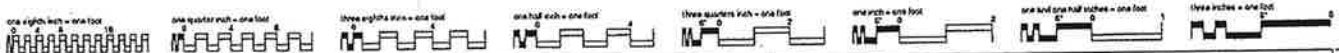

4 SITE PLAN - PROPOSED

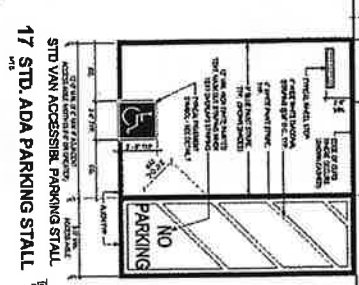

125 BAYSHORE BLVD.
NAVIGATION CENTER

San Francisco Department of
Public Works

ENGINEER: [Signature]

DATE: [Date]

PROJECT NO.: [Number]

SCALE: [Scale]

A0-1

17 STD. ADA ACCESSIBLE PARKING STALL

STANDARD TRUCK STALLS

STANDARD PASSENGER STALLS

STANDARD VAN STALLS

NO PARKING

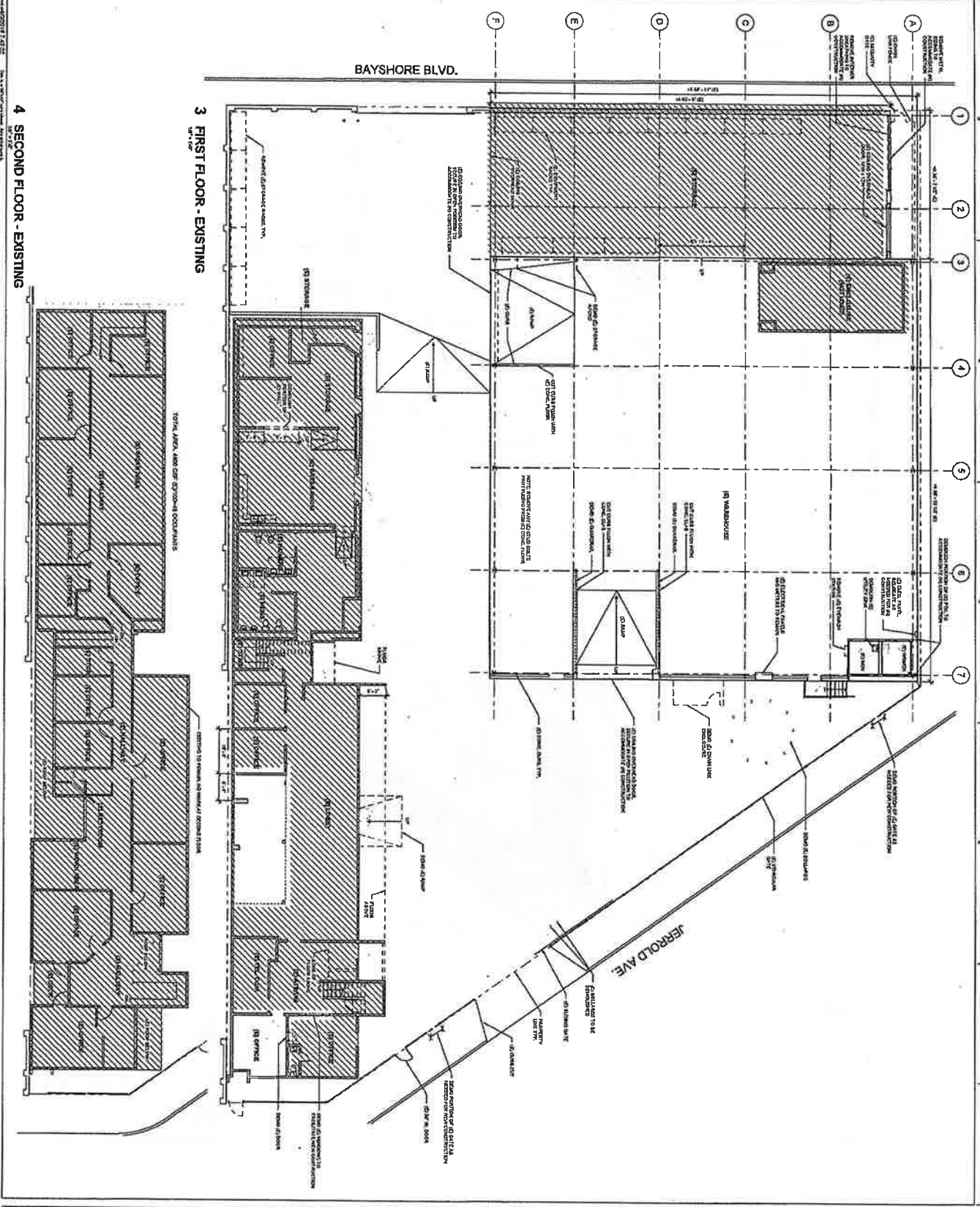

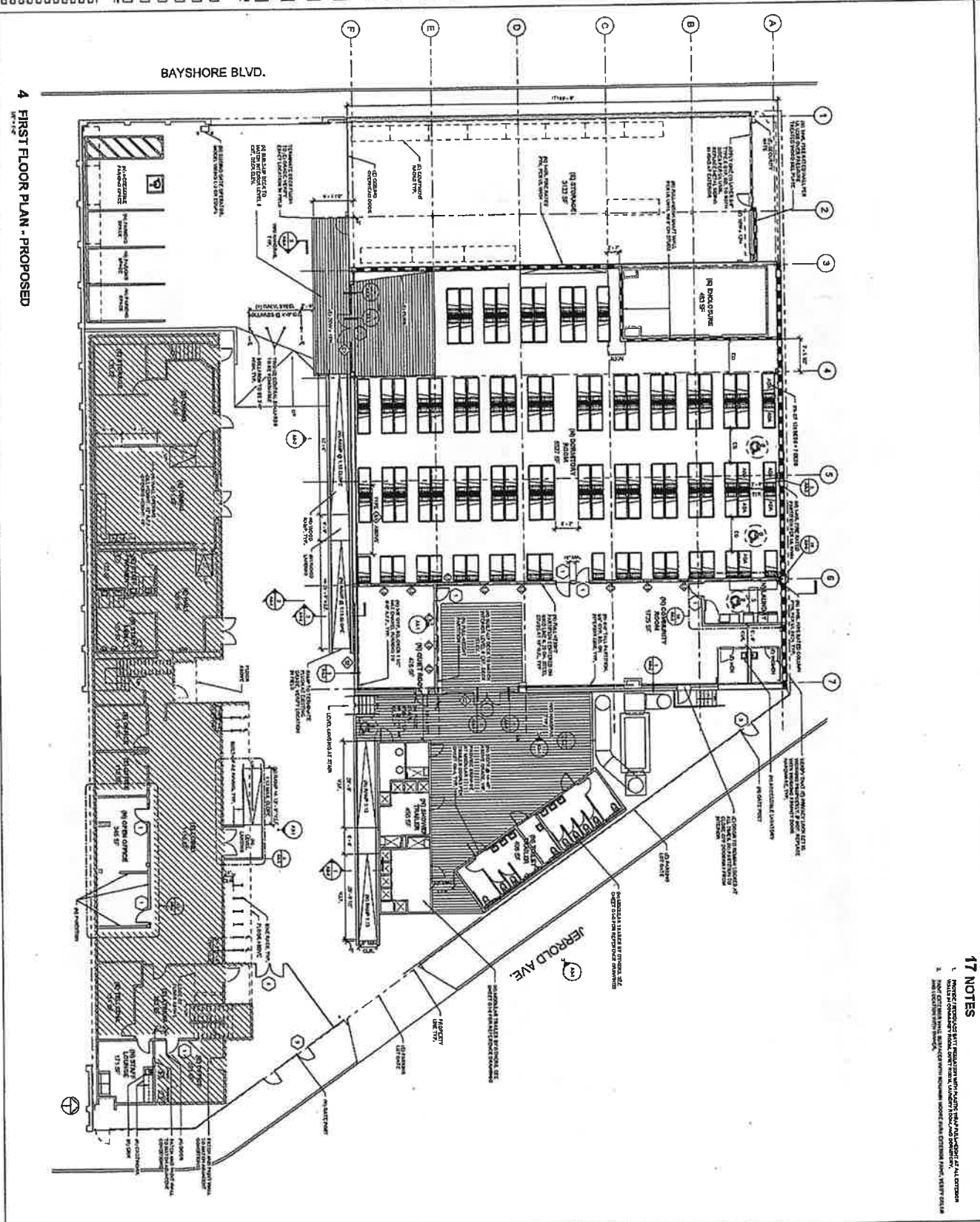
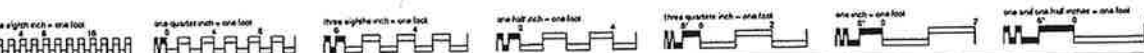
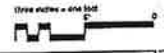

4 FIRST FLOOR PLAN - PROPOSED

17 NOTES

1. THIS SET OF ARCHITECTURAL DRAWINGS IS THE PROPERTY OF THE ARCHITECT AND IS NOT TO BE REPRODUCED OR TRANSMITTED IN ANY FORM OR BY ANY MEANS, ELECTRONIC OR MECHANICAL, INCLUDING PHOTOCOPYING, RECORDING, OR BY ANY INFORMATION STORAGE AND RETRIEVAL SYSTEM, WITHOUT THE WRITTEN PERMISSION OF THE ARCHITECT.
2. THE CONTRACTOR SHALL BE RESPONSIBLE FOR OBTAINING ALL NECESSARY PERMITS AND APPROVALS FROM THE APPROPRIATE AGENCIES.
3. THE CONTRACTOR SHALL BE RESPONSIBLE FOR OBTAINING ALL NECESSARY PERMITS AND APPROVALS FROM THE APPROPRIATE AGENCIES.

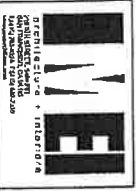

**125 BAYSHORE BLVD.
NAVIGATION CENTER**

San Francisco Department of
Public Works
Engineering Division
1001 Market Street, Room 3000
San Francisco, CA 94102

PROJECT NO.: 20050311
SHEET NO.: 11 OF 17
DATE: 11/17/04
DRAWN BY: J. [Name]
CHECKED BY: [Name]

**BAYSHORE BLVD.
FIRST FLOOR PLAN -
PROPOSED**

A2-1

SCALE: 1/8" = 1'-0"

DATE: 11/17/04

PROJECT NO.: 20050311

SHEET NO.: 11 OF 17

DATE: 11/17/04

DRAWN BY: J. [Name]

CHECKED BY: [Name]

PROJECT NO.: 20050311

SHEET NO.: 11 OF 17

DATE: 11/17/04

DRAWN BY: J. [Name]

CHECKED BY: [Name]

- 0.068 eighth inch = one foot
- 0.125 quarter inch = one foot
- 0.25 eighth inch = one foot
- 0.5 quarter inch = one foot
- 1.0 eighth inch = one foot
- 1.5 quarter inch = one foot
- 2.0 eighth inch = one foot
- 2.5 quarter inch = one foot
- 3.0 eighth inch = one foot
- 3.5 quarter inch = one foot
- 4.0 eighth inch = one foot
- 4.5 quarter inch = one foot
- 5.0 eighth inch = one foot

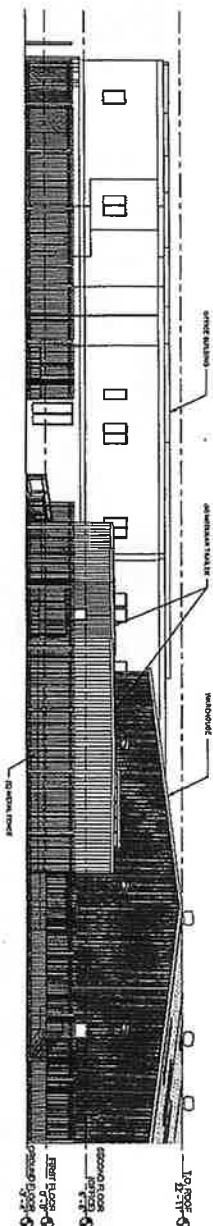

3 JERROLD ELEVATION
1st FLOOR
2nd FLOOR
3rd FLOOR

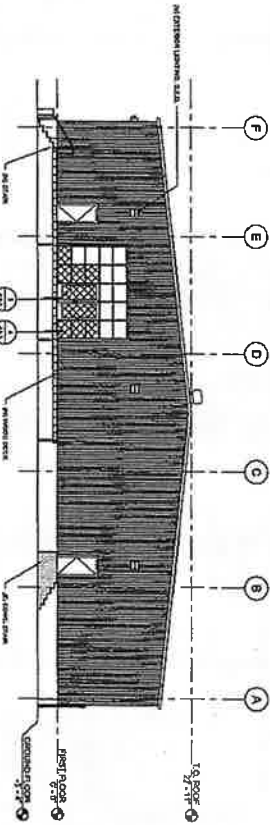

2 EAST ELEVATION
1st FLOOR
2nd FLOOR
3rd FLOOR

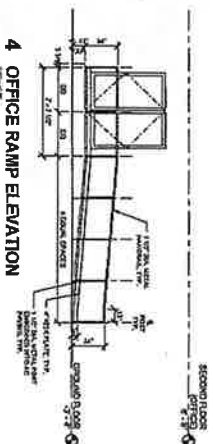

4 OFFICE RAMP ELEVATION

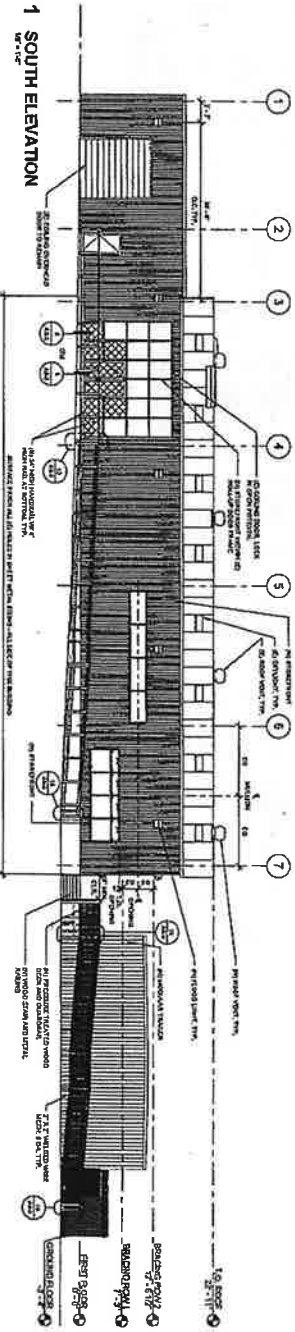

1 SOUTH ELEVATION
1st FLOOR
2nd FLOOR
3rd FLOOR



125 BAYSHORE BLVD. NAVIGATION CENTER

San Francisco Department of Public Works
 PUBLIC WORKS DIVISION
 125 BAYSHORE BLVD., 3RD FLOOR
 SAN FRANCISCO, CA 94133



CONSULTANTS:

NO.	DATE	BY	REVISION
1	11/18/08	ME	ISSUED FOR PERMIT
2	11/20/08	ME	REVISIONS MADE BY PERMITTING AGENCY
3	12/15/08	ME	REVISIONS MADE BY PERMITTING AGENCY
4	1/15/09	ME	REVISIONS MADE BY PERMITTING AGENCY
5	2/10/09	ME	REVISIONS MADE BY PERMITTING AGENCY
6	2/10/09	ME	REVISIONS MADE BY PERMITTING AGENCY
7	2/10/09	ME	REVISIONS MADE BY PERMITTING AGENCY
8	2/10/09	ME	REVISIONS MADE BY PERMITTING AGENCY
9	2/10/09	ME	REVISIONS MADE BY PERMITTING AGENCY
10	2/10/09	ME	REVISIONS MADE BY PERMITTING AGENCY
11	2/10/09	ME	REVISIONS MADE BY PERMITTING AGENCY
12	2/10/09	ME	REVISIONS MADE BY PERMITTING AGENCY
13	2/10/09	ME	REVISIONS MADE BY PERMITTING AGENCY
14	2/10/09	ME	REVISIONS MADE BY PERMITTING AGENCY
15	2/10/09	ME	REVISIONS MADE BY PERMITTING AGENCY
16	2/10/09	ME	REVISIONS MADE BY PERMITTING AGENCY
17	2/10/09	ME	REVISIONS MADE BY PERMITTING AGENCY
18	2/10/09	ME	REVISIONS MADE BY PERMITTING AGENCY
19	2/10/09	ME	REVISIONS MADE BY PERMITTING AGENCY
20	2/10/09	ME	REVISIONS MADE BY PERMITTING AGENCY

A3-1

DATE: 11/18/08
 SCALE: 1/8" = 1'-0"

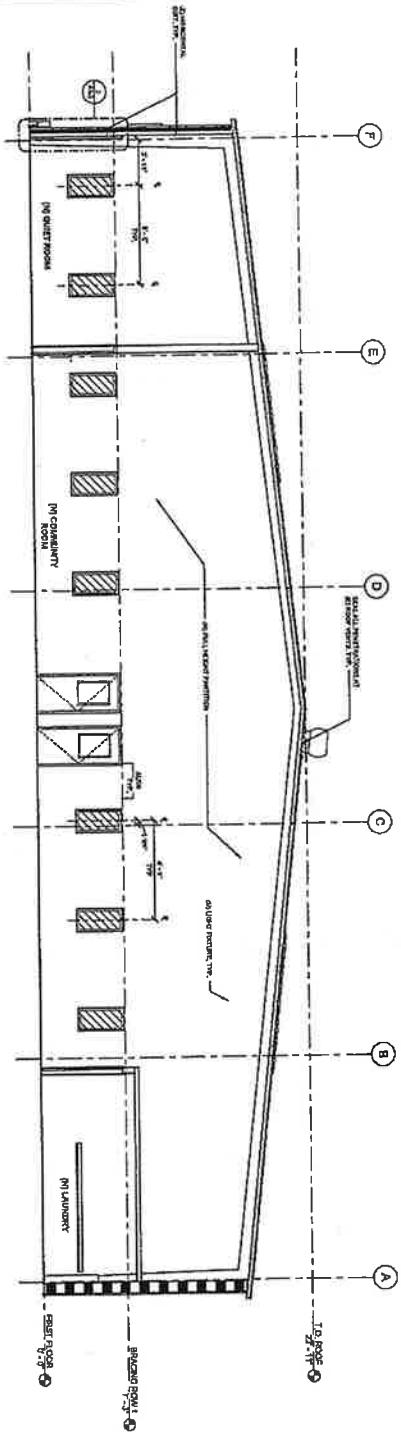
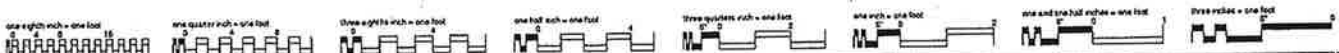

2 SECTION A
1/8" = 1'-0"

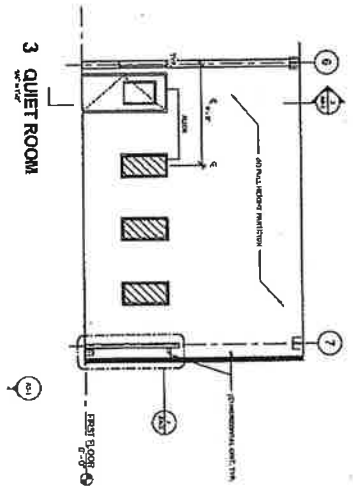

3 QUIET ROOM
1/8" = 1'-0"

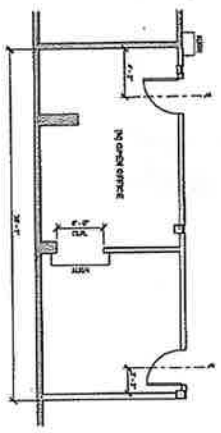

11 (N) OFFICE - ENLARGED PLAN
1/8" = 1'-0"

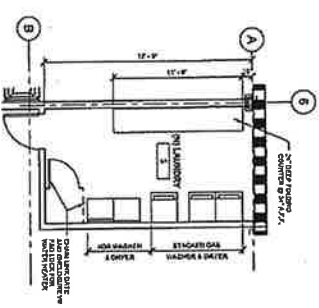

19 (N) LAUNDRY - ENLARGED PLAN
1/8" = 1'-0"

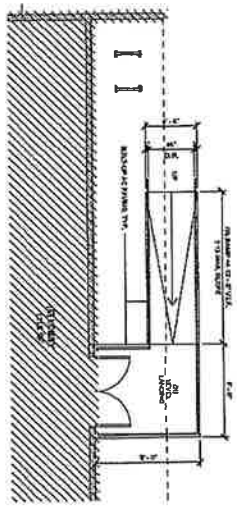

4 ENLARGED PLAN AT OFFICE RAMP
1/8" = 1'-0"

DATE: 02/11/2011 2:53 PM
BY: J. L. [unclear]
PROJECT: [unclear]

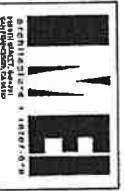

125 BAYSHORE BLVD. NAVIGATION CENTER
San Francisco Department of
Public Works
Engineering Division
201 BAYSHORE BLVD., SUITE 200
SAN FRANCISCO, CA 94133



NO.	DESCRIPTION	DATE	BY
1	ISSUED FOR PERMIT	02/11/2011	JL
2	ISSUED FOR PERMIT	02/11/2011	JL
3	ISSUED FOR PERMIT	02/11/2011	JL
4	ISSUED FOR PERMIT	02/11/2011	JL
5	ISSUED FOR PERMIT	02/11/2011	JL
6	ISSUED FOR PERMIT	02/11/2011	JL
7	ISSUED FOR PERMIT	02/11/2011	JL
8	ISSUED FOR PERMIT	02/11/2011	JL
9	ISSUED FOR PERMIT	02/11/2011	JL
10	ISSUED FOR PERMIT	02/11/2011	JL

BAYSHORE BLVD.

ENLARGED FLOOR PLANS, SECTIONS, INT. ELEVATIONS

A4-1

PROJECT NO.: [unclear]
DRAWN BY: [unclear]
CHECKED BY: [unclear]
DATE: [unclear]

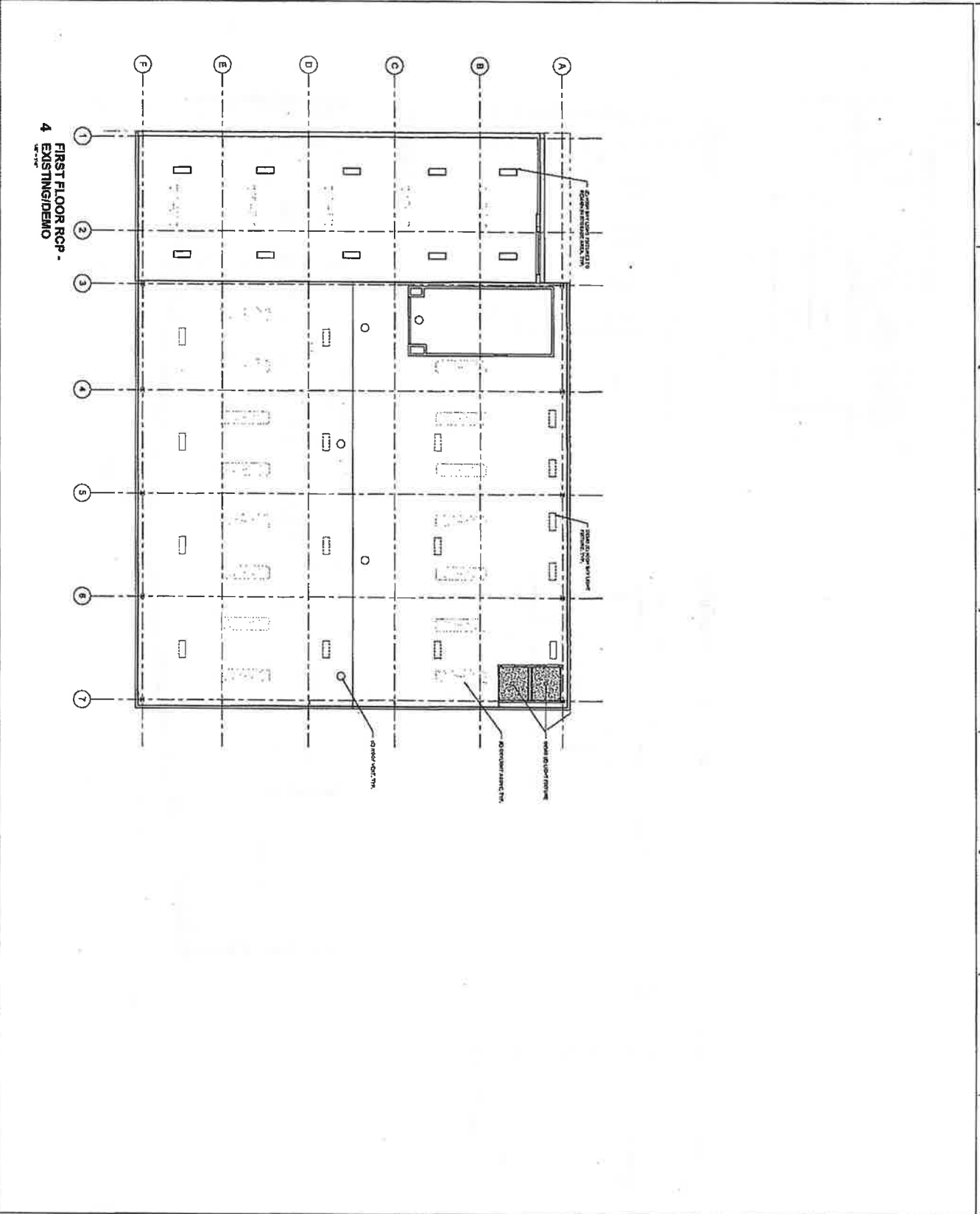

125 BAYSHORE BLVD.
NAVIGATION CENTER

San Francisco Department of
Public Works
Bayshore Project No. 2000



CONSULTANTS:

NO.	NAME	COMPANY	ADDRESS	PHONE
1	ARCHITECT	REYNOLD & MEYER	100 CALIFORNIA STREET, SUITE 1000	415-774-1000
2	STRUCTURAL ENGINEER			
3	ELECTRICAL ENGINEER			
4	Mechanical Engineer			
5	Plumbing Engineer			
6	Fire Protection Engineer			
7	Other			

PROJECT NO.: _____
 DATE: _____
 DRAWN BY: _____
 CHECKED BY: _____
 APPROVED BY: _____
 TITLE: _____

REPLACED CEILING
EXISTING/DEMCO

SCALE: 1/8" = 1'-0"
DATE: _____
A6-1

REYNOLD & MEYER

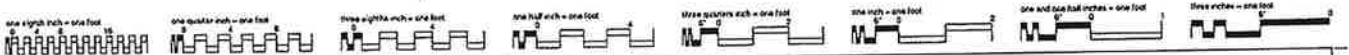

4 FIRST FLOOR RCP - PROPOSED

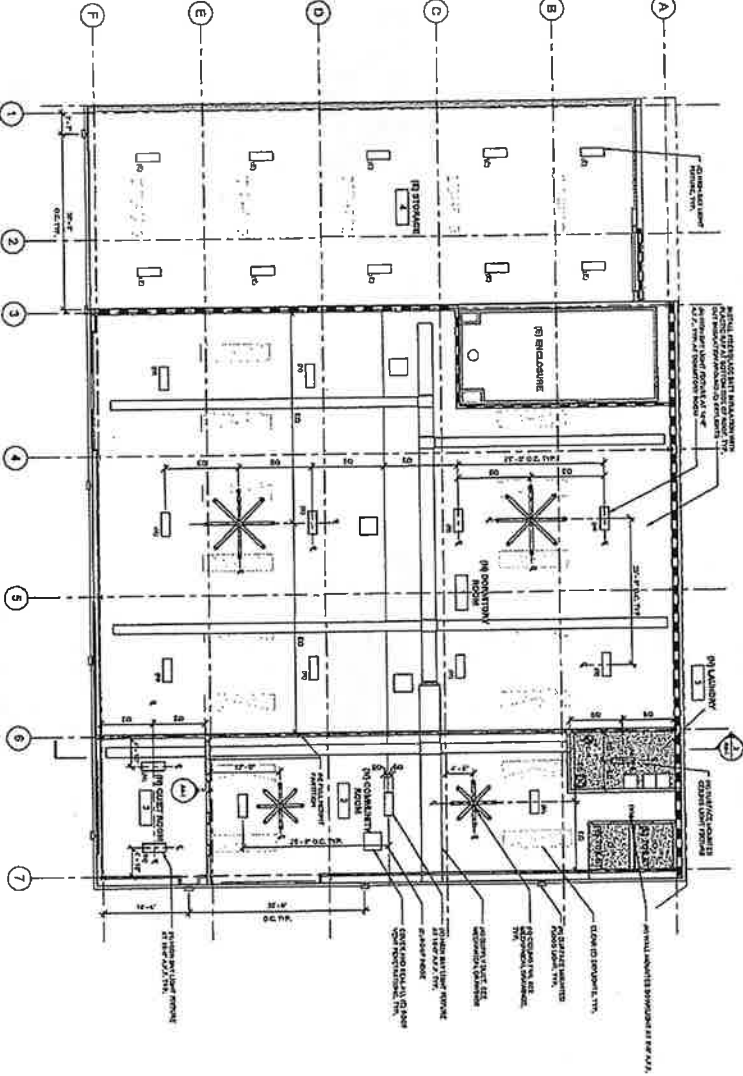

10/20/11 7:00 PM
 11/11/11 10:00 AM

17 NOTES



W&E CONSULTANTS, INC.
 ARCHITECTURAL
 2800 UNIVERSITY AVENUE, SUITE 200
 UNIVERSITY MICROFILMS
 ANN ARBOR, MI 48106-1500
 TEL: 734.761.1800
 FAX: 734.761.1801
 WWW.WANDECO.COM



San Francisco Department of Public Works
 125 BAYSHORE BLVD.
 NAVIGATION CENTER
 SAN FRANCISCO, CA 94133

PROJECT NO:	2011-001
DATE:	10/20/11
DRAWN BY:	AK/ST
CHECKED BY:	AK/ST
SCALE:	AS SHOWN
TITLE:	REFLECTED CEILING PLAN - PROPOSED

BAYSHORE BLVD.
 REFLECTED CEILING PLAN - PROPOSED
 125 BAYSHORE BLVD.
 SAN FRANCISCO, CA 94133

AG-1A
 SCALE: 1/8" = 1'-0"

1 EXTERIOR STOREFRONT SCHEDULE



TYPE OAWNH OAWBHT OAWSTY OAWSTN ALUM STOREFRONT

W-0' 3-0' O-L-1



TYPE OAWNH OAWBHT OAWSTY OAWSTN ALUM STOREFRONT

W-0' 3-0' O-L-1



2 EXTERIOR CURTAIN WALL SCHEDULE

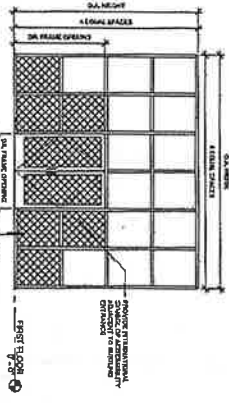

TYPE OAWNH OAWBHT OAWSTY OAWSTN ALUM CURTAIN WALL

W-0' 3-0' O-L-1

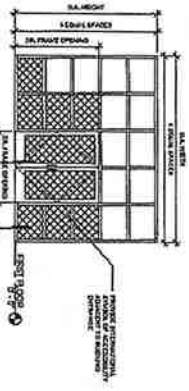

TYPE OAWNH OAWBHT OAWSTY OAWSTN ALUM CURTAIN WALL

W-0' 3-0' O-L-1

3 DOOR SCHEDULE



TYPE OAWNH OAWBHT OAWSTY OAWSTN ALUM CURTAIN WALL

W-0' 3-0' O-L-1



TYPE OAWNH OAWBHT OAWSTY OAWSTN ALUM CURTAIN WALL

W-0' 3-0' O-L-1

11 INTERIOR WINDOW SCHEDULE

MARK	FINISH	TYPE	GLAZING	FRAME	HEIGHT	WIDTH	COMMENTS
1	WOOD	TYPE 1	O-L-1	WOOD	7'-0"	3'-0"	WOOD DOOR, WOOD DOOR, WOOD WINDOW
2	ALUMINUM	TYPE 2	O-L-1	ALUM	7'-0"	3'-0"	ALUM DOOR, ALUM DOOR, ALUM WINDOW
3	STEEL	TYPE 3	O-L-1	STEEL	7'-0"	3'-0"	STEEL DOOR, STEEL DOOR, STEEL WINDOW
4	STEEL	TYPE 4	O-L-1	STEEL	7'-0"	3'-0"	STEEL DOOR, STEEL DOOR, STEEL WINDOW

DOOR TYPES

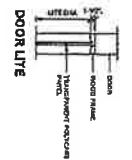
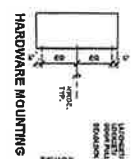
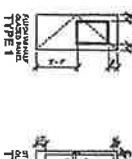

STANDARDS

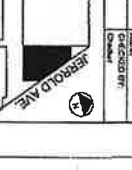
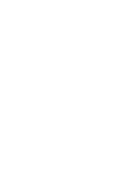

126 BAYSHORE BLVD.
NAVIGATION CENTER

San Francisco Department of
Public Works

San Francisco, CA 94102

CONSULTANTS:

BAYSHORE BLVD.
CURTAIN WALL,
STOREFRONT,
WINDOW AND DOOR
SCHEDULES

SCALE: AS SHOWN

A8-2

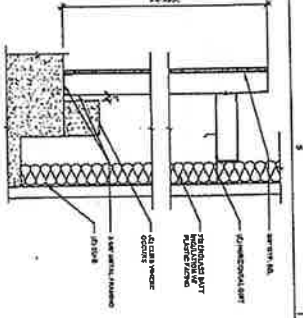
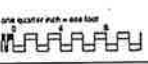
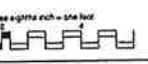
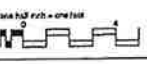
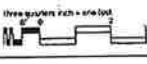
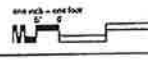
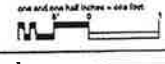

1 FURRING TYPE 1
1/2\"/>

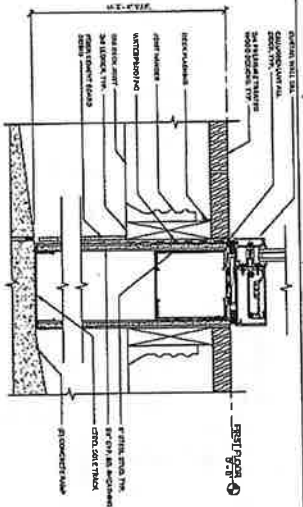

4 (N) WALL @ CURTAINWALL SILL
1\"/>

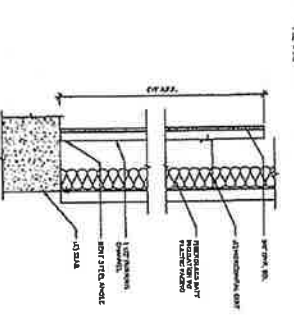

2 FURRING TYPE 2
1\"/>

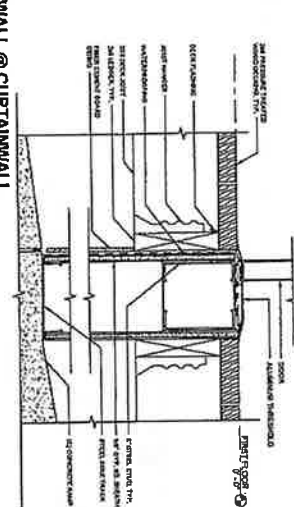

5 (N) WALL @ CURTAINWALL THRESHOLD
1\"/>

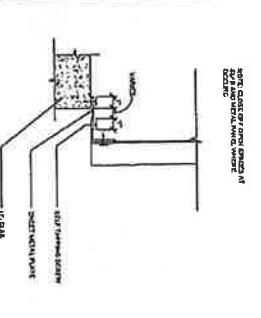

3 CLOSURE PLATE
1\"/>

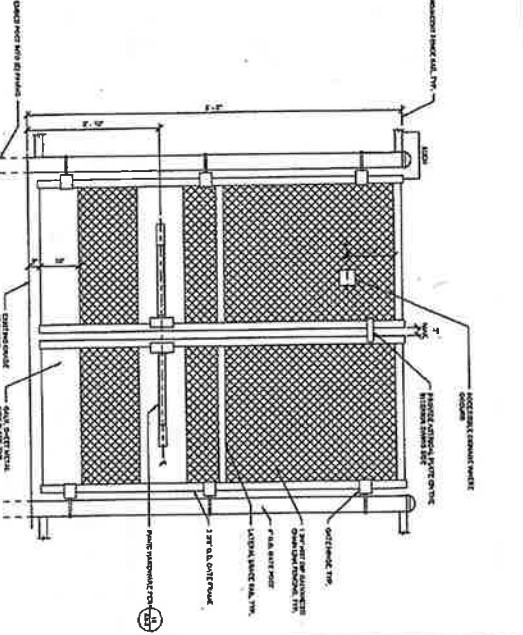

14 TYPE 3 GATE ELEVATION DETAIL
1\"/>

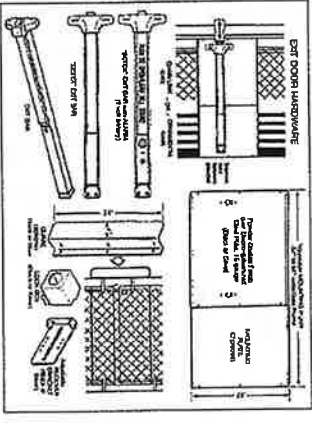

16 CHAIN LINK PANIC HARDWARE
1\"/>



125 BAYSHORE BLVD.
NAVIGATION CENTER
San Francisco Department of
Public Works
125 BAYSHORE BLVD.
SAN FRANCISCO, CA 94133
415.398.1111



PROJECT NO. 125 BAYSHORE BLVD. NAVIGATION CENTER

NO.	DATE	DESCRIPTION	BY
1	12/15/2011	ISSUED FOR PERMIT	DAVID L. WHITE
2	12/15/2011	ISSUED FOR PERMIT	DAVID L. WHITE
3	12/15/2011	ISSUED FOR PERMIT	DAVID L. WHITE
4	12/15/2011	ISSUED FOR PERMIT	DAVID L. WHITE
5	12/15/2011	ISSUED FOR PERMIT	DAVID L. WHITE
6	12/15/2011	ISSUED FOR PERMIT	DAVID L. WHITE
7	12/15/2011	ISSUED FOR PERMIT	DAVID L. WHITE
8	12/15/2011	ISSUED FOR PERMIT	DAVID L. WHITE
9	12/15/2011	ISSUED FOR PERMIT	DAVID L. WHITE
10	12/15/2011	ISSUED FOR PERMIT	DAVID L. WHITE
11	12/15/2011	ISSUED FOR PERMIT	DAVID L. WHITE
12	12/15/2011	ISSUED FOR PERMIT	DAVID L. WHITE
13	12/15/2011	ISSUED FOR PERMIT	DAVID L. WHITE
14	12/15/2011	ISSUED FOR PERMIT	DAVID L. WHITE
15	12/15/2011	ISSUED FOR PERMIT	DAVID L. WHITE
16	12/15/2011	ISSUED FOR PERMIT	DAVID L. WHITE
17	12/15/2011	ISSUED FOR PERMIT	DAVID L. WHITE
18	12/15/2011	ISSUED FOR PERMIT	DAVID L. WHITE
19	12/15/2011	ISSUED FOR PERMIT	DAVID L. WHITE
20	12/15/2011	ISSUED FOR PERMIT	DAVID L. WHITE
21	12/15/2011	ISSUED FOR PERMIT	DAVID L. WHITE
22	12/15/2011	ISSUED FOR PERMIT	DAVID L. WHITE
23	12/15/2011	ISSUED FOR PERMIT	DAVID L. WHITE
24	12/15/2011	ISSUED FOR PERMIT	DAVID L. WHITE
25	12/15/2011	ISSUED FOR PERMIT	DAVID L. WHITE
26	12/15/2011	ISSUED FOR PERMIT	DAVID L. WHITE
27	12/15/2011	ISSUED FOR PERMIT	DAVID L. WHITE
28	12/15/2011	ISSUED FOR PERMIT	DAVID L. WHITE
29	12/15/2011	ISSUED FOR PERMIT	DAVID L. WHITE
30	12/15/2011	ISSUED FOR PERMIT	DAVID L. WHITE
31	12/15/2011	ISSUED FOR PERMIT	DAVID L. WHITE
32	12/15/2011	ISSUED FOR PERMIT	DAVID L. WHITE
33	12/15/2011	ISSUED FOR PERMIT	DAVID L. WHITE
34	12/15/2011	ISSUED FOR PERMIT	DAVID L. WHITE
35	12/15/2011	ISSUED FOR PERMIT	DAVID L. WHITE
36	12/15/2011	ISSUED FOR PERMIT	DAVID L. WHITE
37	12/15/2011	ISSUED FOR PERMIT	DAVID L. WHITE
38	12/15/2011	ISSUED FOR PERMIT	DAVID L. WHITE
39	12/15/2011	ISSUED FOR PERMIT	DAVID L. WHITE
40	12/15/2011	ISSUED FOR PERMIT	DAVID L. WHITE
41	12/15/2011	ISSUED FOR PERMIT	DAVID L. WHITE
42	12/15/2011	ISSUED FOR PERMIT	DAVID L. WHITE
43	12/15/2011	ISSUED FOR PERMIT	DAVID L. WHITE
44	12/15/2011	ISSUED FOR PERMIT	DAVID L. WHITE
45	12/15/2011	ISSUED FOR PERMIT	DAVID L. WHITE
46	12/15/2011	ISSUED FOR PERMIT	DAVID L. WHITE
47	12/15/2011	ISSUED FOR PERMIT	DAVID L. WHITE
48	12/15/2011	ISSUED FOR PERMIT	DAVID L. WHITE
49	12/15/2011	ISSUED FOR PERMIT	DAVID L. WHITE
50	12/15/2011	ISSUED FOR PERMIT	DAVID L. WHITE

PROJECT NO. 125 BAYSHORE BLVD. NAVIGATION CENTER
 DATE 12/15/2011
 DRAWN BY DAVID L. WHITE
 CHECKED BY DAVID L. WHITE
 SCALE 1/8\"/>

A8-3

125 BAYSHORE BLVD. NAVIGATION CENTER
 San Francisco Department of Public Works
 125 BAYSHORE BLVD.
 SAN FRANCISCO, CA 94133
 415.398.1111

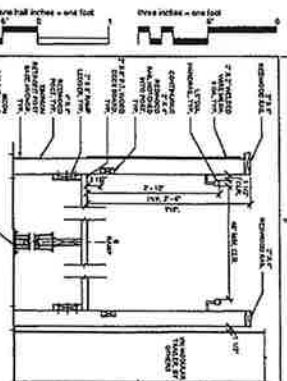

1 GUARDRAIL AT RAMP
1'-0"

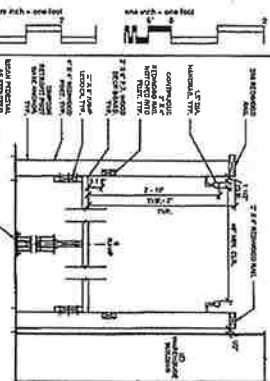

2 HANDRAIL AT RAMP
1'-0"

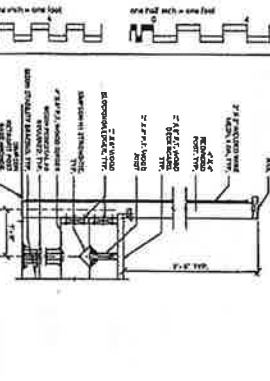

3 GUARDRAIL AT DECK
1'-0"

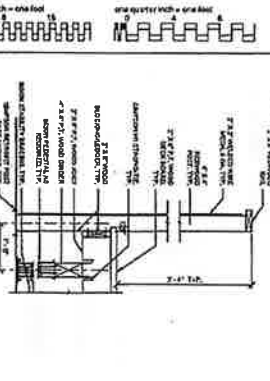

4 GUARDRAIL AT DECK
1'-0"

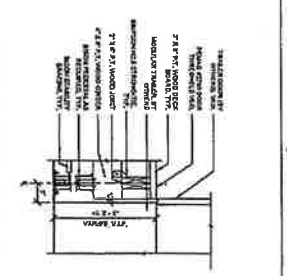

5 DECK AT BUILDING & DOOR THRESHOLD
1'-0"

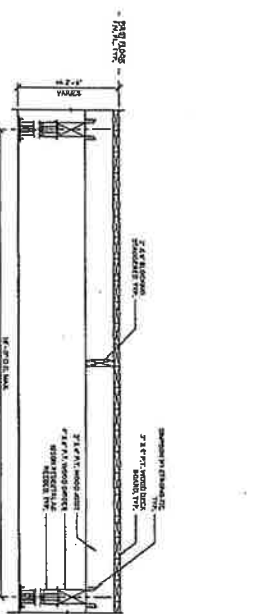

6 WOOD DECK SECTION, TYP.
1'-0"

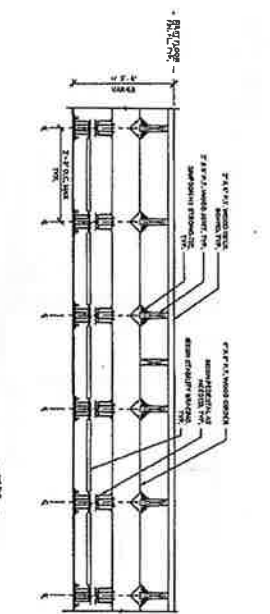

7 WOOD DECK SECTION, TYP.
1'-0"

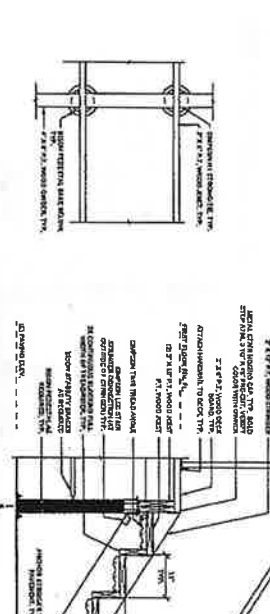

8 DECK CONNECTION PLAN DETAIL
1'-0"

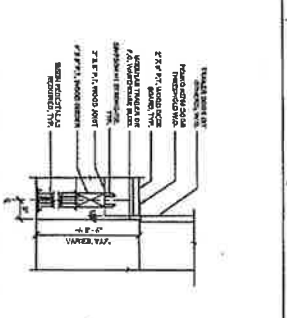

9 DECK AT BUILDING & DOOR THRESHOLD
1'-0"

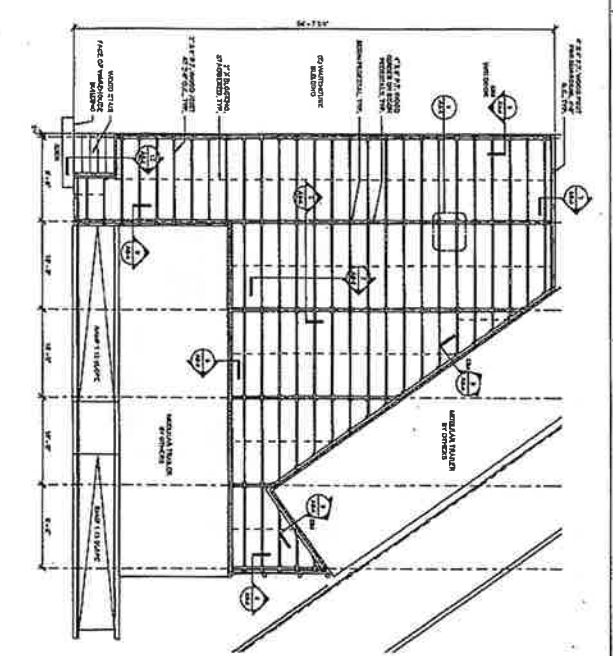

14 FRAMING PLAN - DECK
1'-0"

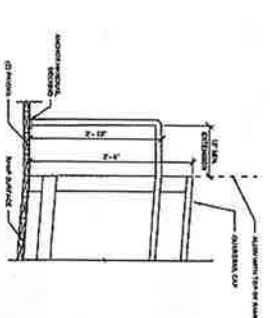

15 RAILING EXTENSION DETAIL AT RAMP
1'-0"

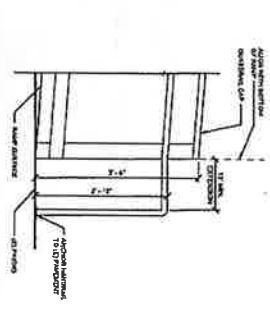

19 RAILING EXTENSION DETAIL AT RAMP
1'-0"

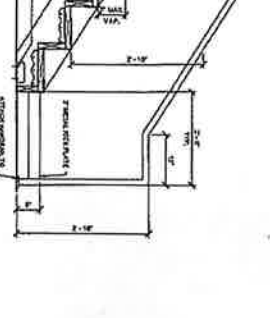

12 DECK AT BUILDING & DOOR THRESHOLD
1'-0"

	125 BAYSHORE BLVD. NAVIGATION CENTER San Francisco Department of Public Works CIVIL PROJECT NO. 2008	
	SHEET TITLE: DECK DETAILS AND FRAMING PLAN	PROJECT NO.: DRAWING NO.: DATE: DESIGNED BY: CHECKED BY:
A8-4	BAYSHORE BLVD. 	

Fire Rated System Design - UL U415

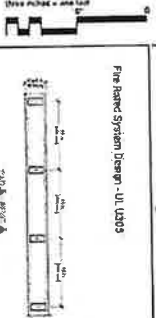

UL U305
 Exterior Wall Wood Stud (cast-in-place)
 Fire Rating: 1 hour
 System: 4374
 Thickness: 4 1/2\"/>

Assembly Details

- 1. Cast-in-place concrete slab on top of steel beam with fire-rated joint.
- 2. Steel beam with fire-rated joint.
- 3. Exterior wall wood stud (cast-in-place).
- 4. Fire-rated joint.
- 5. Fire-rated joint.
- 6. Fire-rated joint.
- 7. Fire-rated joint.
- 8. Fire-rated joint.
- 9. Fire-rated joint.
- 10. Fire-rated joint.
- 11. Fire-rated joint.
- 12. Fire-rated joint.
- 13. Fire-rated joint.
- 14. Fire-rated joint.
- 15. Fire-rated joint.
- 16. Fire-rated joint.
- 17. Fire-rated joint.
- 18. Fire-rated joint.
- 19. Fire-rated joint.
- 20. Fire-rated joint.

2 U305

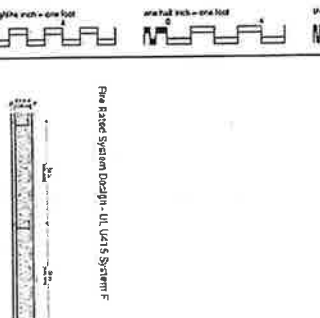

UL U415 System F
 Slab Wall Stud (Non-beam-rod)
 Fire Rating: 2 hour
 RUC: S3
 Stud: USC-040599
 System: 5172
 Thickness: 4 1/2\"/>

Assembly Details

- 1. Cast-in-place concrete slab on top of steel beam with fire-rated joint.
- 2. Steel beam with fire-rated joint.
- 3. Slab wall stud (non-beam-rod).
- 4. Fire-rated joint.
- 5. Fire-rated joint.
- 6. Fire-rated joint.
- 7. Fire-rated joint.
- 8. Fire-rated joint.
- 9. Fire-rated joint.
- 10. Fire-rated joint.
- 11. Fire-rated joint.
- 12. Fire-rated joint.
- 13. Fire-rated joint.
- 14. Fire-rated joint.
- 15. Fire-rated joint.
- 16. Fire-rated joint.
- 17. Fire-rated joint.
- 18. Fire-rated joint.
- 19. Fire-rated joint.
- 20. Fire-rated joint.

4 U415

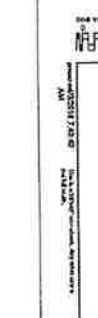

Detail for No. W404

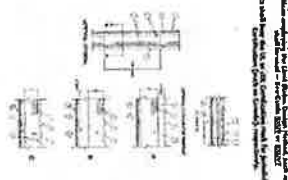

11 W404

Assembly Details

- 1. Cast-in-place concrete slab on top of steel beam with fire-rated joint.
- 2. Steel beam with fire-rated joint.
- 3. Fire-rated joint.
- 4. Fire-rated joint.
- 5. Fire-rated joint.
- 6. Fire-rated joint.
- 7. Fire-rated joint.
- 8. Fire-rated joint.
- 9. Fire-rated joint.
- 10. Fire-rated joint.
- 11. Fire-rated joint.
- 12. Fire-rated joint.
- 13. Fire-rated joint.
- 14. Fire-rated joint.
- 15. Fire-rated joint.
- 16. Fire-rated joint.
- 17. Fire-rated joint.
- 18. Fire-rated joint.
- 19. Fire-rated joint.
- 20. Fire-rated joint.

Detail for No. X524

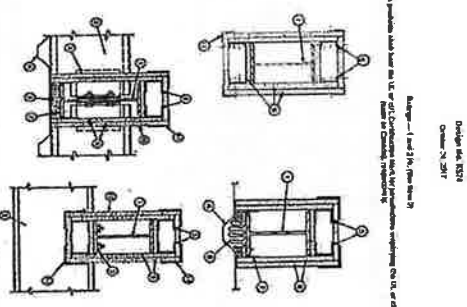

16 X524

Assembly Details

- 1. Cast-in-place concrete slab on top of steel beam with fire-rated joint.
- 2. Steel beam with fire-rated joint.
- 3. Fire-rated joint.
- 4. Fire-rated joint.
- 5. Fire-rated joint.
- 6. Fire-rated joint.
- 7. Fire-rated joint.
- 8. Fire-rated joint.
- 9. Fire-rated joint.
- 10. Fire-rated joint.
- 11. Fire-rated joint.
- 12. Fire-rated joint.
- 13. Fire-rated joint.
- 14. Fire-rated joint.
- 15. Fire-rated joint.
- 16. Fire-rated joint.
- 17. Fire-rated joint.
- 18. Fire-rated joint.
- 19. Fire-rated joint.
- 20. Fire-rated joint.



San Francisco Department of
 Public Works
 Project No. 507
 San Francisco, CA 94102



NO.	DATE	DESCRIPTION	BY
1	11/11/2011	ISSUED FOR PERMIT	W.E.
2	11/11/2011	REVISION	W.E.
3	11/11/2011	REVISION	W.E.
4	11/11/2011	REVISION	W.E.
5	11/11/2011	REVISION	W.E.
6	11/11/2011	REVISION	W.E.
7	11/11/2011	REVISION	W.E.
8	11/11/2011	REVISION	W.E.
9	11/11/2011	REVISION	W.E.
10	11/11/2011	REVISION	W.E.
11	11/11/2011	REVISION	W.E.
12	11/11/2011	REVISION	W.E.
13	11/11/2011	REVISION	W.E.
14	11/11/2011	REVISION	W.E.
15	11/11/2011	REVISION	W.E.
16	11/11/2011	REVISION	W.E.
17	11/11/2011	REVISION	W.E.
18	11/11/2011	REVISION	W.E.
19	11/11/2011	REVISION	W.E.
20	11/11/2011	REVISION	W.E.

CONTRACT INFORMATION

PROJECT NO. 507
 SHEET TITLE: FIRE RATING DETAILS
 SHEET NO. A8-5

PROJECT LOCATION

125 BAYSHORE BLVD.
 NAVIGATION CENTER
 SAN FRANCISCO, CA 94133

CLIENT

San Francisco Department of Public Works

DATE

11/11/2011

SCALE

1/2" = 1'-0"

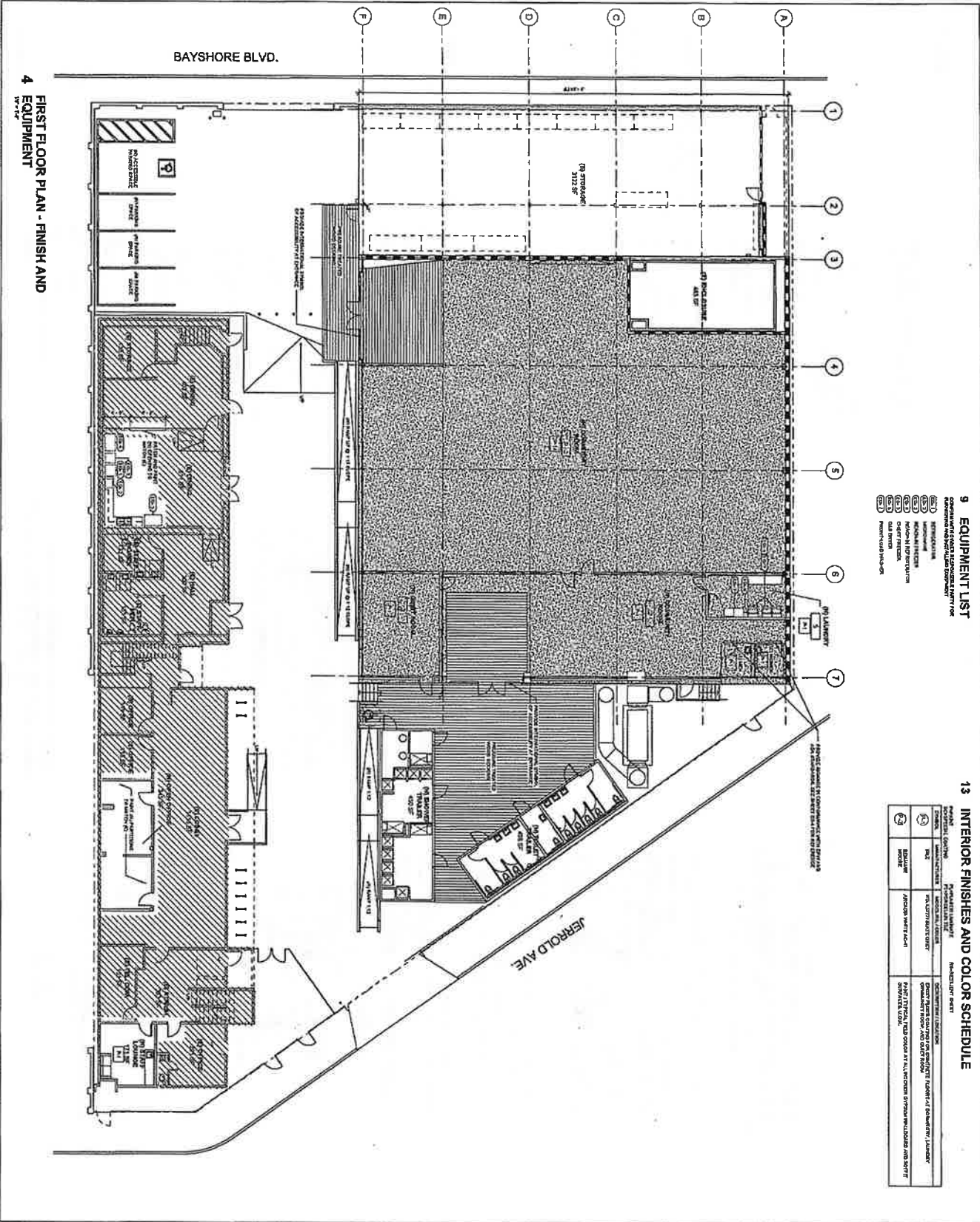
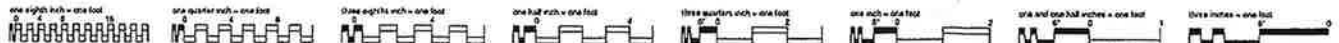

4 FIRST FLOOR PLAN - FINISH AND EQUIPMENT
 1/4" = 1'-0"

- 9 EQUIPMENT LIST**
 CONTAINING EQUIPMENT SCHEDULES LIST FOR
 INTERIOR FINISHES AND COLOR SCHEDULE
- (1) REFRIGERATOR
 - (2) MICROWAVE
 - (3) SINK
 - (4) STOVE
 - (5) DISHWASHER
 - (6) CUPBOARD
 - (7) COUNTER
 - (8) SINK
 - (9) REFRIGERATOR

13 INTERIOR FINISHES AND COLOR SCHEDULE

FINISH	DESCRIPTION	REMARKS
(1)	REFRIGERATOR	REFRIGERATOR
(2)	MICROWAVE	MICROWAVE
(3)	SINK	SINK
(4)	STOVE	STOVE
(5)	DISHWASHER	DISHWASHER
(6)	CUPBOARD	CUPBOARD
(7)	COUNTER	COUNTER
(8)	SINK	SINK
(9)	REFRIGERATOR	REFRIGERATOR

125 BAYSHORE BLVD.
NAVIGATION CENTER

San Francisco Department of
 Planning and Public Works
 CLIENT PROJECT NO. XXXX

CONSULTANTS:

MEI

125 BAYSHORE BLVD.
 NAVIGATION CENTER

PROJECT TITLE:
FINISH AND EQUIPMENT PLAN

SCALE: As indicated

A10-1

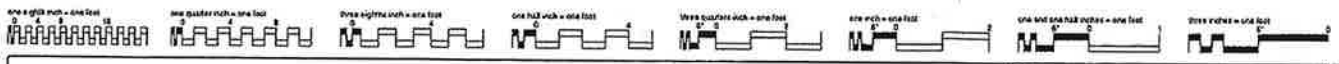

FAN SCHEDULE

FAN TAG	MANUFACTURER & MODEL NO.	SERVICE	FAN CAPACITY				MOTOR				VOLTAGE (V)	PHASE	SPEED (RPM)	REMARKS
			CFM	HP	WIND. SPEED (FT/MIN)	WIND. TEMP. (°F)	HP	PH	V	PH				
1	ESPRESSO	(4) CONFERENCE ROOM	-	1.5	12 FT	-	1.5	135	240	1	60	100	3	
2	ESPRESSO	(4) CONFERENCE ROOM	-	1.25	12 FT	-	1.5	135	240	1	60	100	3	
3	ESPRESSO	(4) CONFERENCE ROOM	-	1.25	12 FT	-	1.5	135	240	1	60	100	3	
4	ESPRESSO	(4) CONFERENCE ROOM	-	1.25	12 FT	-	1.5	135	240	1	60	100	3	
5	ESPRESSO	(4) CONFERENCE ROOM	-	1.25	12 FT	-	1.5	135	240	1	60	100	3	
6	ESPRESSO	(4) CONFERENCE ROOM	-	1.25	12 FT	-	1.5	135	240	1	60	100	3	
7	ESPRESSO	(4) CONFERENCE ROOM	-	1.25	12 FT	-	1.5	135	240	1	60	100	3	
8	ESPRESSO	(4) CONFERENCE ROOM	-	1.25	12 FT	-	1.5	135	240	1	60	100	3	
9	ESPRESSO	(4) CONFERENCE ROOM	-	1.25	12 FT	-	1.5	135	240	1	60	100	3	
10	ESPRESSO	(4) CONFERENCE ROOM	-	1.25	12 FT	-	1.5	135	240	1	60	100	3	

- ① FAN OPERATIONAL WHEN UNIT STARTS.
- ② FAN OFF WHEN UNIT STOPS.

GAS FIRED OUTDOOR HEATING AND VENTILATING UNIT

UNIT TAG	MANUFACTURER & MODEL NO.	SERVICE	CFM	HP	WIND. SPEED (FT/MIN)	WIND. TEMP. (°F)	HP	PH	V	PH	Hz	REMARKS	
1	ESPRESSO	(4) CONFERENCE ROOM	-	1.5	12 FT	-	1.5	135	240	1	60	100	3

- ① PROVIDE KEYS TO FILTERS AND FILTER HOODS.
- ② PROVIDE DATA SOURCE DIRECTIONS.
- ③ ELECTRICIAN MANUFACTURE GAS CONTROL.
- ④ SAFETY PRESENT.
- ⑤ AIRFLOW PROTECTIVE SWITCH.
- ⑥ PROVIDE OUTSIDE AIR DAMPER.

DIFFUSERS, REGISTERS AND GRILLES SCHEDULE

DIFFUSER TAG	DESCRIPTION	MANUFACTURER	MODEL NO.	SIZE (IN)	TYPE	INSTALLATION	LEVEL	REMARKS
1	CANOPY SUPPLY DIFFUSER	TITUS	100-4A	24x24	GRILLE	20	00	

- ① PROVIDE OUTSIDE AIR DAMPER.
- ② PROVIDE SQUARE TO ROUND NECK ADAPTER AS REQUIRED.



San Francisco Department of Public Works
 125 BAYSHORE BLVD.
 NAVIGATION CENTER



S.J. SWINNERS
 REGISTERED PROFESSIONAL ENGINEER
 STATE OF CALIFORNIA
 LICENSE NO. 10000



PROJECT INFORMATION

PROJECT NO.: _____
 PROJECT NAME: _____
 DATE: _____
 DRAWN BY: _____
 CHECKED BY: _____

SCALE: _____

MECHANICAL

MO-2

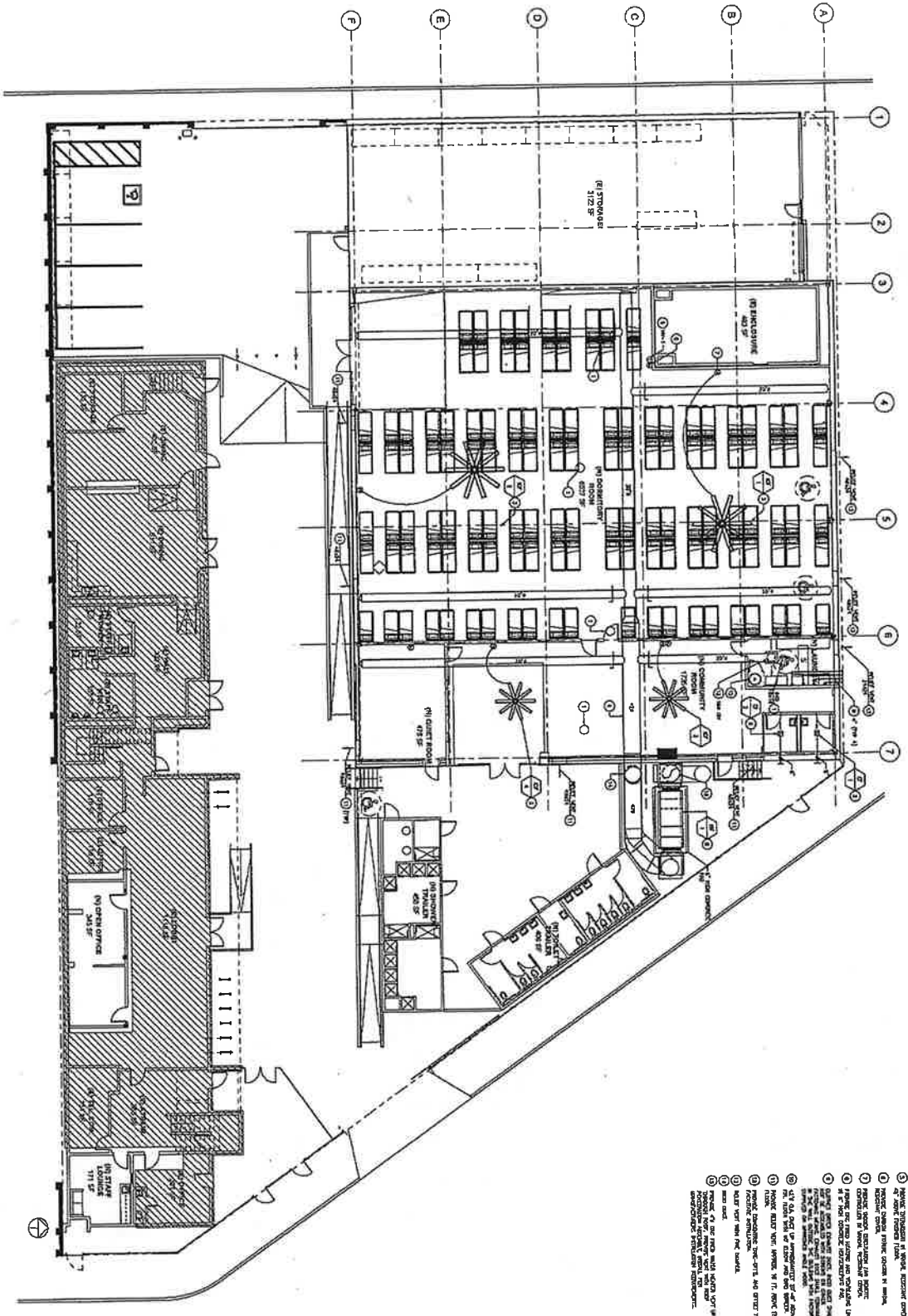
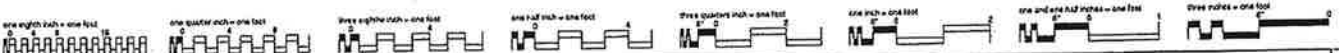

- NOTE: SEE SHEET M2-1 FOR COMPLETE MECHANICAL PLAN.
- 1) ROOMS SHOWN IN THIS PLAN ARE NOT TO BE CONSIDERED AS PART OF THE MECHANICAL SYSTEM.
 - 2) ROOMS SHOWN IN THIS PLAN ARE NOT TO BE CONSIDERED AS PART OF THE MECHANICAL SYSTEM.
 - 3) ROOMS SHOWN IN THIS PLAN ARE NOT TO BE CONSIDERED AS PART OF THE MECHANICAL SYSTEM.
 - 4) ROOMS SHOWN IN THIS PLAN ARE NOT TO BE CONSIDERED AS PART OF THE MECHANICAL SYSTEM.
 - 5) ROOMS SHOWN IN THIS PLAN ARE NOT TO BE CONSIDERED AS PART OF THE MECHANICAL SYSTEM.
 - 6) ROOMS SHOWN IN THIS PLAN ARE NOT TO BE CONSIDERED AS PART OF THE MECHANICAL SYSTEM.
 - 7) ROOMS SHOWN IN THIS PLAN ARE NOT TO BE CONSIDERED AS PART OF THE MECHANICAL SYSTEM.
 - 8) ROOMS SHOWN IN THIS PLAN ARE NOT TO BE CONSIDERED AS PART OF THE MECHANICAL SYSTEM.
 - 9) ROOMS SHOWN IN THIS PLAN ARE NOT TO BE CONSIDERED AS PART OF THE MECHANICAL SYSTEM.

	128 BAYSHORE BLVD. NAVIGATION CENTER	San Francisco Department of Public Works
	SI ENGINEERS 300 PAVAN & CORNER PARK SAN FRANCISCO, CA 94103 PH: (415) 774-1200 FAX: (415) 774-1201	San Francisco Department of Public Works
	JEKROD & VINE	San Francisco Department of Public Works
	JEKROD & VINE 100 CALIFORNIA STREET SAN FRANCISCO, CA 94111 PH: (415) 774-1200 FAX: (415) 774-1201	San Francisco Department of Public Works

M2-1

Press Notes = one foot

one inch = one foot

one inch = one foot

one quarter inch = one foot

one half inch = one foot

one eighth inch = one foot

one quarter inch = one foot

one eighth inch = one foot

7 HOUSEKEEPING PAD DETAIL

NOT TO SCALE

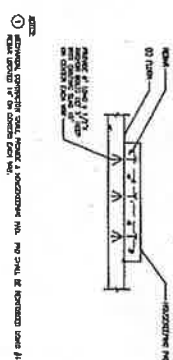

6 HV/1 MOUNTING DETAIL

NOT TO SCALE

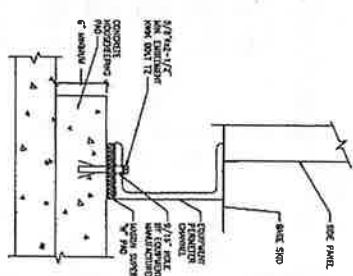

5 CEILING EXHAUST FAN DETAIL

NOT TO SCALE

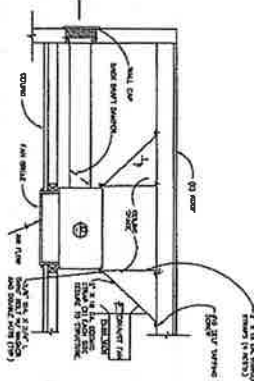

4 RELIEF AIR WITH FIRE DAMPER MOUNTING DETAIL

NOT TO SCALE

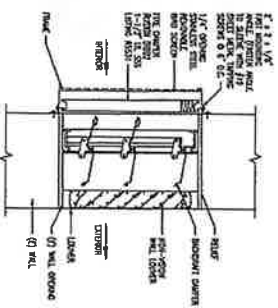

3 DUCT RISER SUPPORT

NOT TO SCALE

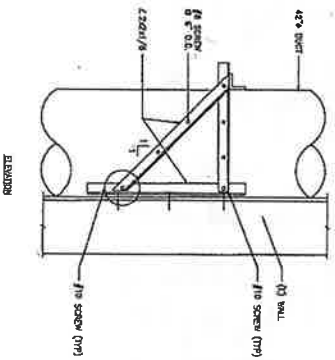
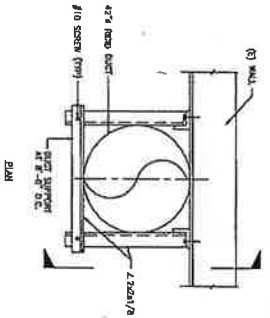

2 RELIEF AIR OPENING AND MOUNTING DETAIL

NOT TO SCALE

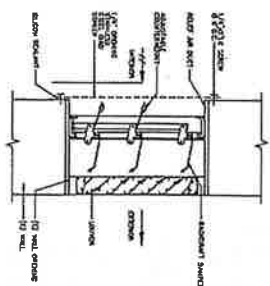

ME
MECHANICAL ENGINEERS
1425 BAYSHORE BLVD.,
SAN FRANCISCO, CA 94134
TELEPHONE: (415) 775-1100
FACSIMILE: (415) 775-1101

San Francisco Department of
Public Works
1425 BAYSHORE BLVD.,
SAN FRANCISCO, CA 94134
TELEPHONE: (415) 775-1100
FACSIMILE: (415) 775-1101

ST ENGINEERS
1425 BAYSHORE BLVD.,
SAN FRANCISCO, CA 94134
TELEPHONE: (415) 775-1100
FACSIMILE: (415) 775-1101

NO.	DATE	DESCRIPTION	BY

PROJECT NO.:
DATE:
DRAWN BY:
CHECKED BY:
TITLE: **MECHANICAL**

M6-1

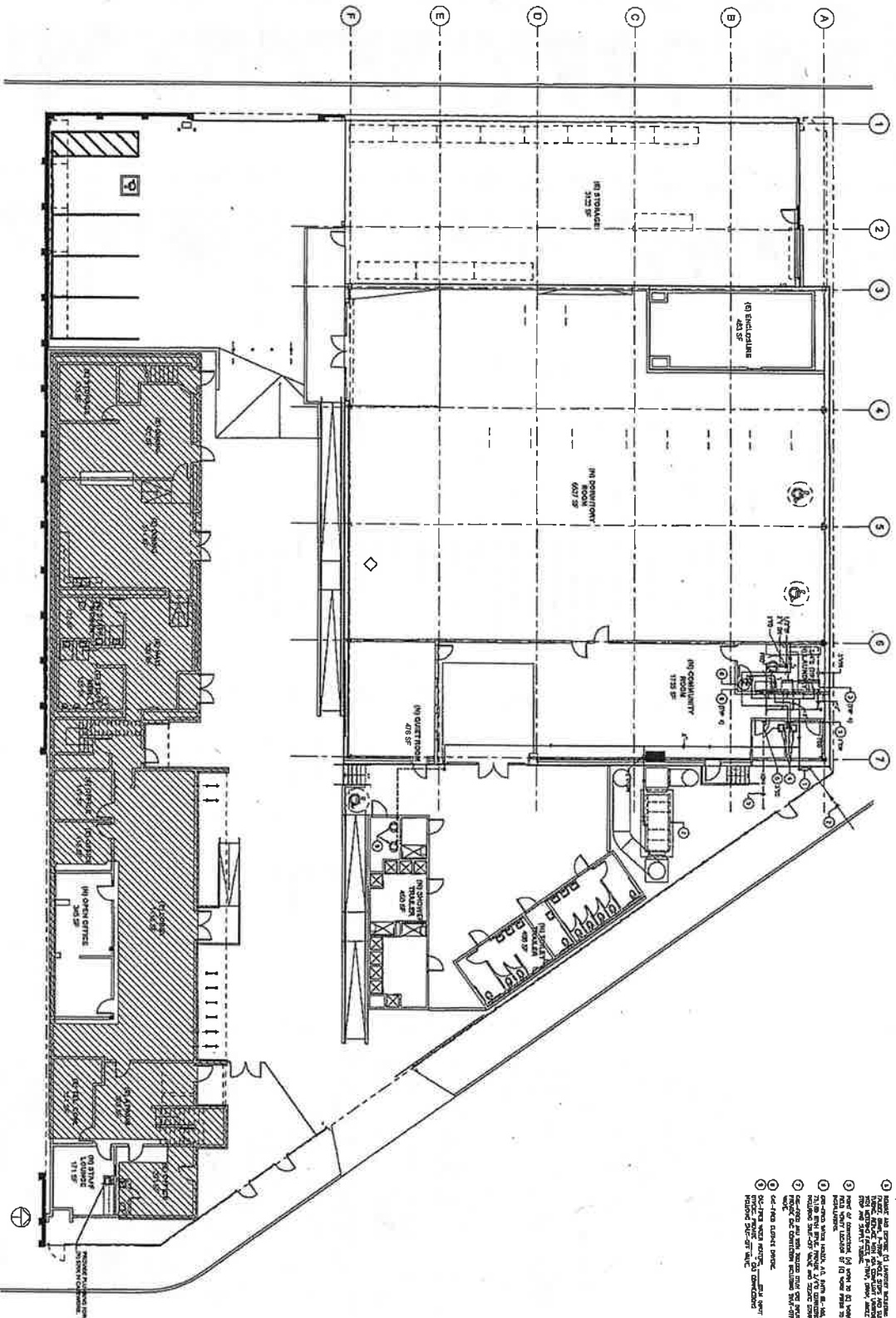
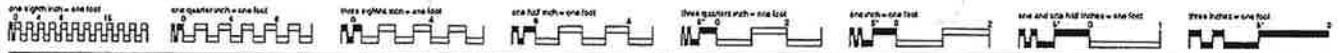

- GENERAL NOTES:**
1. CONTRACTOR SHALL VERIFY EXISTING CONDITIONS AND LOCATIONS OF ALL UTILITIES BEFORE ANY CONSTRUCTION.
 2. ALL WORK SHALL BE IN ACCORDANCE WITH THE LATEST EDITIONS OF THE CALIFORNIA PLUMBING CODE AND THE SAN FRANCISCO PLUMBING CODE.
 3. ALL WORK SHALL BE IN ACCORDANCE WITH THE LATEST EDITIONS OF THE CALIFORNIA MECHANICAL CODE AND THE SAN FRANCISCO MECHANICAL CODE.
 4. ALL WORK SHALL BE IN ACCORDANCE WITH THE LATEST EDITIONS OF THE CALIFORNIA ELECTRICAL CODE AND THE SAN FRANCISCO ELECTRICAL CODE.
 5. ALL WORK SHALL BE IN ACCORDANCE WITH THE LATEST EDITIONS OF THE CALIFORNIA FIRE AND SAFETY CODE AND THE SAN FRANCISCO FIRE AND SAFETY CODE.
 6. ALL WORK SHALL BE IN ACCORDANCE WITH THE LATEST EDITIONS OF THE CALIFORNIA BUILDING CODE AND THE SAN FRANCISCO BUILDING CODE.
 7. ALL WORK SHALL BE IN ACCORDANCE WITH THE LATEST EDITIONS OF THE CALIFORNIA LANDMARK PRESERVATION ACT AND THE SAN FRANCISCO LANDMARK PRESERVATION ACT.
 8. ALL WORK SHALL BE IN ACCORDANCE WITH THE LATEST EDITIONS OF THE CALIFORNIA HISTORIC PRESERVATION ACT AND THE SAN FRANCISCO HISTORIC PRESERVATION ACT.
 9. ALL WORK SHALL BE IN ACCORDANCE WITH THE LATEST EDITIONS OF THE CALIFORNIA ANTI-DISCRIMINATION ACT AND THE SAN FRANCISCO ANTI-DISCRIMINATION ACT.
 10. ALL WORK SHALL BE IN ACCORDANCE WITH THE LATEST EDITIONS OF THE CALIFORNIA ENVIRONMENTAL QUALITY ACT AND THE SAN FRANCISCO ENVIRONMENTAL QUALITY ACT.

	125 BAYSHORE BLVD. NAVIGATION CENTER San Francisco Department of Public Works BAYSHORE BLVD. NAVIGATION CENTER SAN FRANCISCO, CA 94133	
	SI ENGINEERS 305 ZAY ASHBY BLVD. SAN FRANCISCO, CA 94102 TEL: 415-774-1100 FAX: 415-774-1101	
PROJECT NO.: 125-BAYSHORE-01 DATE: 08/15/01 DESIGNED BY: J. L. BROWN CHECKED BY: J. L. BROWN SCALE: 1/8" = 1'-0"	PROJECT NO.: 125-BAYSHORE-01 DATE: 08/15/01 DESIGNED BY: J. L. BROWN CHECKED BY: J. L. BROWN SCALE: 1/8" = 1'-0"	PROJECT NO.: 125-BAYSHORE-01 DATE: 08/15/01 DESIGNED BY: J. L. BROWN CHECKED BY: J. L. BROWN SCALE: 1/8" = 1'-0"

P2-1

SYMBOL	ABBREVIATION	DESCRIPTION
(Symbol: Circle with horizontal line)	ACTING DIRECTOR	SEVERY 100
(Symbol: Circle with horizontal line)	SEVERY 100	SEVERY 100
(Symbol: Circle with horizontal line)	SEVERY 100	SEVERY 100
(Symbol: Circle with horizontal line)	SEVERY 100	SEVERY 100

SYMBOL	ABBREVIATION	DESCRIPTION
(Symbol: Circle with horizontal line)	ACTING DIRECTOR	SEVERY 100
(Symbol: Circle with horizontal line)	SEVERY 100	SEVERY 100
(Symbol: Circle with horizontal line)	SEVERY 100	SEVERY 100
(Symbol: Circle with horizontal line)	SEVERY 100	SEVERY 100

SYMBOL	ABBREVIATION	DESCRIPTION
(Symbol: Circle with horizontal line)	ACTING DIRECTOR	SEVERY 100
(Symbol: Circle with horizontal line)	SEVERY 100	SEVERY 100
(Symbol: Circle with horizontal line)	SEVERY 100	SEVERY 100
(Symbol: Circle with horizontal line)	SEVERY 100	SEVERY 100

SYMBOL	ABBREVIATION	DESCRIPTION
(Symbol: Circle with horizontal line)	ACTING DIRECTOR	SEVERY 100
(Symbol: Circle with horizontal line)	SEVERY 100	SEVERY 100
(Symbol: Circle with horizontal line)	SEVERY 100	SEVERY 100
(Symbol: Circle with horizontal line)	SEVERY 100	SEVERY 100

SYMBOL	ABBREVIATION	DESCRIPTION
(Symbol: Circle with horizontal line)	ACTING DIRECTOR	SEVERY 100
(Symbol: Circle with horizontal line)	SEVERY 100	SEVERY 100
(Symbol: Circle with horizontal line)	SEVERY 100	SEVERY 100
(Symbol: Circle with horizontal line)	SEVERY 100	SEVERY 100

SYMBOL	ABBREVIATION	DESCRIPTION
(Symbol: Circle with horizontal line)	ACTING DIRECTOR	SEVERY 100
(Symbol: Circle with horizontal line)	SEVERY 100	SEVERY 100
(Symbol: Circle with horizontal line)	SEVERY 100	SEVERY 100
(Symbol: Circle with horizontal line)	SEVERY 100	SEVERY 100

SYMBOL	ABBREVIATION	DESCRIPTION
(Symbol: Circle with horizontal line)	ACTING DIRECTOR	SEVERY 100
(Symbol: Circle with horizontal line)	SEVERY 100	SEVERY 100
(Symbol: Circle with horizontal line)	SEVERY 100	SEVERY 100
(Symbol: Circle with horizontal line)	SEVERY 100	SEVERY 100

SYMBOL	ABBREVIATION	DESCRIPTION
(Symbol: Circle with horizontal line)	ACTING DIRECTOR	SEVERY 100
(Symbol: Circle with horizontal line)	SEVERY 100	SEVERY 100
(Symbol: Circle with horizontal line)	SEVERY 100	SEVERY 100
(Symbol: Circle with horizontal line)	SEVERY 100	SEVERY 100

SYMBOL	ABBREVIATION	DESCRIPTION
(Symbol: Circle with horizontal line)	ACTING DIRECTOR	SEVERY 100
(Symbol: Circle with horizontal line)	SEVERY 100	SEVERY 100
(Symbol: Circle with horizontal line)	SEVERY 100	SEVERY 100
(Symbol: Circle with horizontal line)	SEVERY 100	SEVERY 100

W E

ARCHITECTS & ENGINEERS
 125 BAYSHORE BLVD.
 NAVIGATION CENTER
 San Francisco Department of Public Works
 CONTRACT NO. 00300

ST. FRANCISCO
 SEAL OF THE CITY OF SAN FRANCISCO
 OFFICE OF THE PUBLIC WORKS COMMISSIONER
 333 CALIFORNIA STREET, SAN FRANCISCO, CALIF. 94102
 TELEPHONE 333-2111

GENERAL NOTES

- THE FIRE PROTECTION SYSTEM SHALL COMPLY WITH THE FOLLOWING CODES AND STANDARDS:
 - INTERNATIONAL FIRE CODE, 2010 EDITION WITH SAN FRANCISCO AMENDMENTS.
 - CALIFORNIA FIRE CODE, 2010 EDITION.
 - NATIONAL FIRE PROTECTION ASSOCIATION (NFPA) HAZARDOUS LIQUID COMMODITY CODE, 2011 EDITION.
 - NATIONAL FIRE PROTECTION ASSOCIATION (NFPA) HAZARDOUS SOLID COMMODITY CODE, 2011 EDITION.
 - NATIONAL FIRE PROTECTION ASSOCIATION (NFPA) HAZARDOUS GAS COMMODITY CODE, 2011 EDITION.
 - NATIONAL FIRE PROTECTION ASSOCIATION (NFPA) HAZARDOUS FLAMMABLE LIQUID COMMODITY CODE, 2011 EDITION.
 - NATIONAL FIRE PROTECTION ASSOCIATION (NFPA) HAZARDOUS FLAMMABLE SOLID COMMODITY CODE, 2011 EDITION.
 - NATIONAL FIRE PROTECTION ASSOCIATION (NFPA) HAZARDOUS FLAMMABLE GAS COMMODITY CODE, 2011 EDITION.
 - NATIONAL FIRE PROTECTION ASSOCIATION (NFPA) HAZARDOUS CORROSIVE LIQUID COMMODITY CODE, 2011 EDITION.
 - NATIONAL FIRE PROTECTION ASSOCIATION (NFPA) HAZARDOUS CORROSIVE SOLID COMMODITY CODE, 2011 EDITION.
 - NATIONAL FIRE PROTECTION ASSOCIATION (NFPA) HAZARDOUS CORROSIVE GAS COMMODITY CODE, 2011 EDITION.
 - NATIONAL FIRE PROTECTION ASSOCIATION (NFPA) HAZARDOUS OXIDIZING LIQUID COMMODITY CODE, 2011 EDITION.
 - NATIONAL FIRE PROTECTION ASSOCIATION (NFPA) HAZARDOUS OXIDIZING SOLID COMMODITY CODE, 2011 EDITION.
 - NATIONAL FIRE PROTECTION ASSOCIATION (NFPA) HAZARDOUS OXIDIZING GAS COMMODITY CODE, 2011 EDITION.
 - NATIONAL FIRE PROTECTION ASSOCIATION (NFPA) HAZARDOUS TOXIC CORROSIVE LIQUID COMMODITY CODE, 2011 EDITION.
 - NATIONAL FIRE PROTECTION ASSOCIATION (NFPA) HAZARDOUS TOXIC CORROSIVE SOLID COMMODITY CODE, 2011 EDITION.
 - NATIONAL FIRE PROTECTION ASSOCIATION (NFPA) HAZARDOUS TOXIC CORROSIVE GAS COMMODITY CODE, 2011 EDITION.
 - NATIONAL FIRE PROTECTION ASSOCIATION (NFPA) HAZARDOUS REACTIVE LIQUID COMMODITY CODE, 2011 EDITION.
 - NATIONAL FIRE PROTECTION ASSOCIATION (NFPA) HAZARDOUS REACTIVE SOLID COMMODITY CODE, 2011 EDITION.
 - NATIONAL FIRE PROTECTION ASSOCIATION (NFPA) HAZARDOUS REACTIVE GAS COMMODITY CODE, 2011 EDITION.
 - NATIONAL FIRE PROTECTION ASSOCIATION (NFPA) HAZARDOUS FLAMMABLE TOXIC CORROSIVE LIQUID COMMODITY CODE, 2011 EDITION.
 - NATIONAL FIRE PROTECTION ASSOCIATION (NFPA) HAZARDOUS FLAMMABLE TOXIC CORROSIVE SOLID COMMODITY CODE, 2011 EDITION.
 - NATIONAL FIRE PROTECTION ASSOCIATION (NFPA) HAZARDOUS FLAMMABLE TOXIC CORROSIVE GAS COMMODITY CODE, 2011 EDITION.
 - NATIONAL FIRE PROTECTION ASSOCIATION (NFPA) HAZARDOUS FLAMMABLE TOXIC CORROSIVE LIQUID COMMODITY CODE, 2011 EDITION.
 - NATIONAL FIRE PROTECTION ASSOCIATION (NFPA) HAZARDOUS FLAMMABLE TOXIC CORROSIVE SOLID COMMODITY CODE, 2011 EDITION.
 - NATIONAL FIRE PROTECTION ASSOCIATION (NFPA) HAZARDOUS FLAMMABLE TOXIC CORROSIVE GAS COMMODITY CODE, 2011 EDITION.
 - NATIONAL FIRE PROTECTION ASSOCIATION (NFPA) HAZARDOUS FLAMMABLE TOXIC CORROSIVE LIQUID COMMODITY CODE, 2011 EDITION.
 - NATIONAL FIRE PROTECTION ASSOCIATION (NFPA) HAZARDOUS FLAMMABLE TOXIC CORROSIVE SOLID COMMODITY CODE, 2011 EDITION.
 - NATIONAL FIRE PROTECTION ASSOCIATION (NFPA) HAZARDOUS FLAMMABLE TOXIC CORROSIVE GAS COMMODITY CODE, 2011 EDITION.

BAYSHORE BLVD.
 BRUNO AVE.
 LEGEND AND ABBREVIATIONS

SCALE: 1/4" = 1'-0"

DATE: 08/14/11

PROJECT NO.: 00300

PROJECT TITLE: BRUNO AVE. SEWER MAINS
 BRUNO AVE. SEWER MAINS

DRAWING NO.: 20

CONTRACT NO.: 00300

SHEET NO.: F0-1

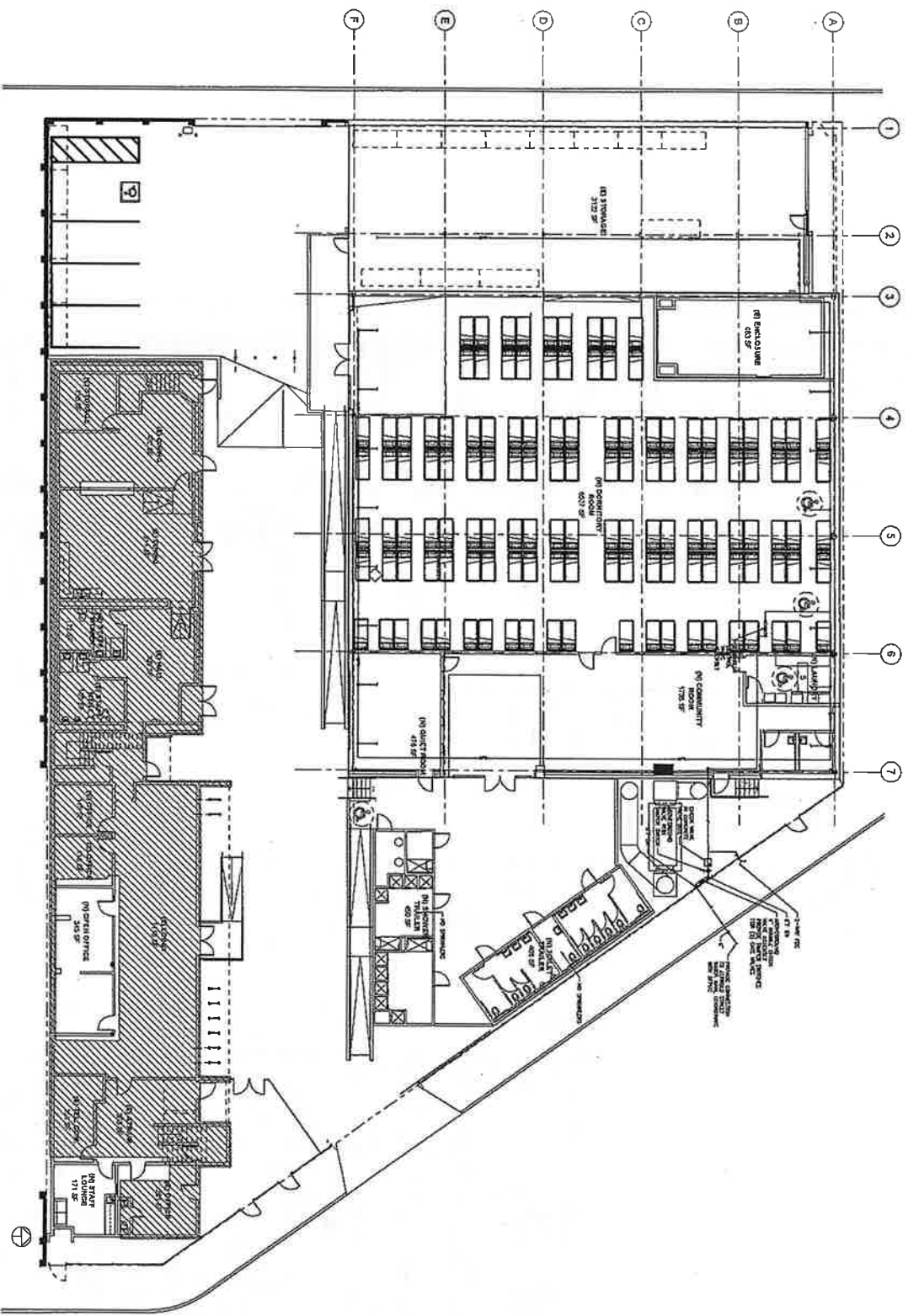

NOTES:
 1. CHECK ALL ROOMS & CORRIDORS FOR FIRE ALARMS.
 2. THE CONTRACTOR SHALL BE RESPONSIBLE FOR OBTAINING ALL NECESSARY PERMITS FROM THE CITY OF SAN FRANCISCO.
 3. ALL WORK SHALL BE IN ACCORDANCE WITH THE LATEST EDITIONS OF THE CALIFORNIA BUILDING CODES.
 4. THE CONTRACTOR SHALL BE RESPONSIBLE FOR OBTAINING ALL NECESSARY PERMITS FROM THE CITY OF SAN FRANCISCO.

<p>PROJECT: 125 BAYSHORE BLVD. FIRST FLOOR PLAN FIRE PROTECTION</p>	<p>CLIENT: San Francisco Department of Public Works</p> <p>DESIGNER: G.P. ENGINEERS 2050 Market Street San Francisco, CA 94114 Phone: (415) 774-1111 Fax: (415) 774-1112 Website: www.gpe.com</p>	<p>DATE: 08/14/2008</p> <p>SCALE: 1/4" = 1'-0"</p> <p>PROJECT NO.: 08-014</p>	<p>CONSULTANTS:</p> <p>DATE: 08/14/2008</p>
--	--	--	---

F2-1

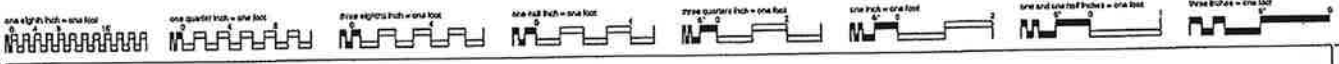

NO.	DESCRIPTION	QTY.	UNIT
1	1/2" RIGID PVC CONDUIT		
2	3/4" RIGID PVC CONDUIT		
3	1" RIGID PVC CONDUIT		
4	1 1/2" RIGID PVC CONDUIT		
5	2" RIGID PVC CONDUIT		
6	3" RIGID PVC CONDUIT		
7	4" RIGID PVC CONDUIT		
8	6" RIGID PVC CONDUIT		

NOTES:

1. ALL CONDUIT SHALL BE RIGID PVC UNLESS OTHERWISE SPECIFIED.
2. CONDUIT SHALL BE INSTALLED IN ACCORDANCE WITH THE NATIONAL ELECTRICAL CODE (NEC).
3. CONDUIT SHALL BE SUPPORTED AT INTERVALS OF 4 FEET.
4. CONDUIT SHALL BE PROTECTED FROM MECHANICAL DAMAGE.
5. CONDUIT SHALL BE IDENTIFIED BY COLOR OR TAGGING.
6. CONDUIT SHALL BE INSTALLED IN A MANNER THAT DOES NOT OBSTRUCT OTHER SERVICES.
7. CONDUIT SHALL BE INSTALLED IN A MANNER THAT DOES NOT CAUSE DAMAGE TO EXISTING STRUCTURE.
8. CONDUIT SHALL BE INSTALLED IN A MANNER THAT DOES NOT CAUSE DAMAGE TO LANDSCAPE.

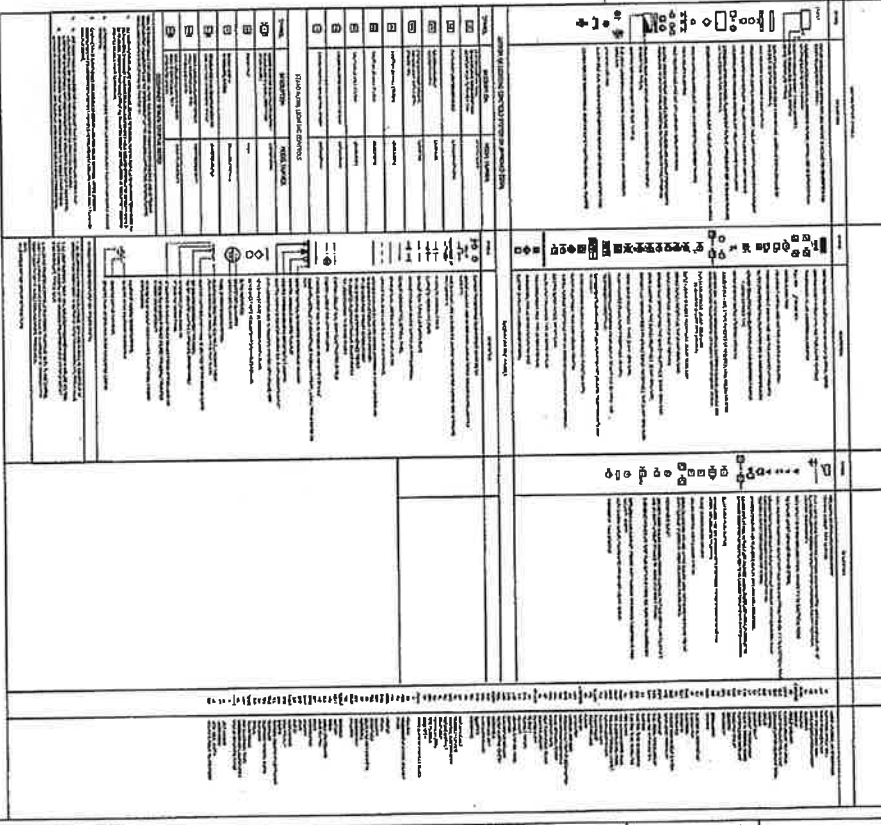

<p>WENTWORTH ELECTRIC INC. 1000 Folsom Street San Francisco, CA 94117 Tel: (415) 774-1111</p>	<p>HARRIS RESEARCH ASSOCIATES 1000 Folsom Street San Francisco, CA 94117 Tel: (415) 774-1111</p>	<p>San Francisco Department of Public Works 125 BAYSHORE BLVD. NAVIGATION CENTER SAN FRANCISCO, CA 94133 Tel: (415) 338-3300</p>	<p>CONTRACT NO. 2000-001</p>
			<p>PROJECT NO. 2000-001</p>
<p>DATE: 01/15/00</p>	<p>BY: [Signature]</p>	<p>FOR: [Signature]</p>	<p>PROJECT NO. 2000-001</p>
<p>125 BAYSHORE BLVD. NAVIGATION CENTER SAN FRANCISCO, CA 94133</p>	<p>125 BAYSHORE BLVD. NAVIGATION CENTER SAN FRANCISCO, CA 94133</p>	<p>125 BAYSHORE BLVD. NAVIGATION CENTER SAN FRANCISCO, CA 94133</p>	<p>125 BAYSHORE BLVD. NAVIGATION CENTER SAN FRANCISCO, CA 94133</p>

E0.1

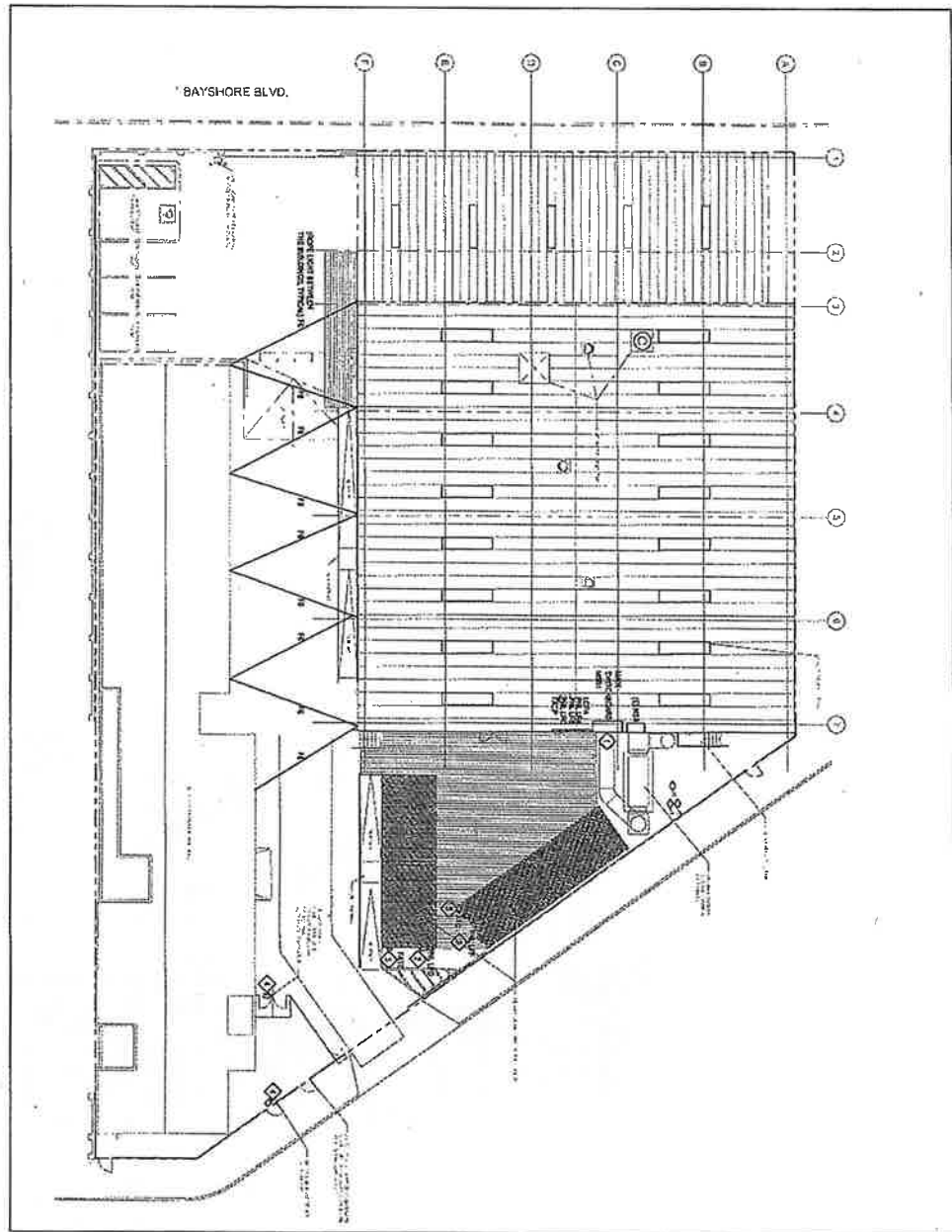
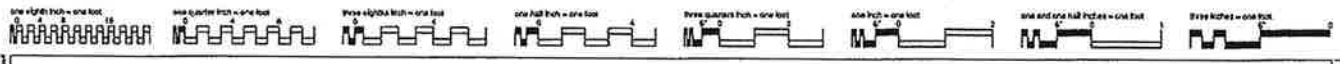

① ELECTRICAL SITE PLAN
SCALE = 1/8" = 1'-0"

GENERAL SHEET NOTES:

- A. ALL ELECTRICAL EQUIPMENT SHALL BE NEW UNLESS OTHERWISE NOTED.
- B. SEE ELECTRICAL WORK DRAWING FOR DIMENSIONS.
- C. CONDUCT EXISTING WORK TO PANEL 125A/125B.
- D. CONDUCT WORKING DRAWING TO PANEL 125A/125B.

KEYED NOTES:

- ◇ EQUIPMENT SHALL BE COMPATIBLE WITH PANEL 125A/125B.
- ◇ PANEL 125A/125B SHALL BE PROVIDED BY THE CLIENT.
- ◇ PANEL 125A/125B SHALL BE PROVIDED BY THE CLIENT.
- ◇ LOCATIONS IN THIS DRAWING SHALL BE RECONSTRUCTED TO MATCH THE RECONSTRUCTION DRAWING PROVIDED BY THE CLIENT.



**125 BAYSHORE BLVD.
NAVIGATION CENTER**

San Francisco Department of
Public Works



HRA
445 Market Street, Suite 1110
San Francisco, CA 94102
Tel: 415.778.1111
Fax: 415.778.1112

PROJECT NO.	DATE	DESIGNER	SCALE
125 BAYSHORE BLVD.	01/15/2018	J. M. [Signature]	1/8" = 1'-0"
<p>E1.1</p>			

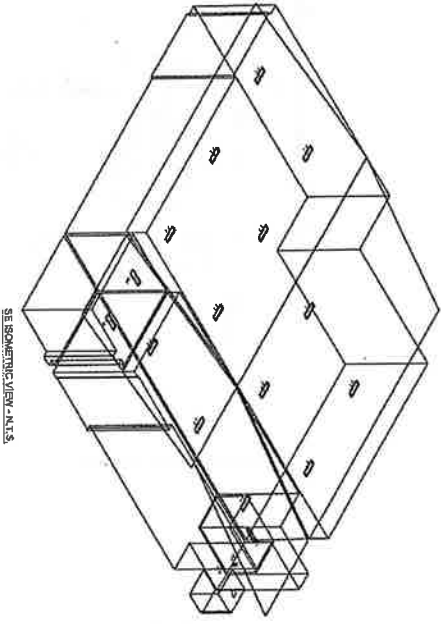
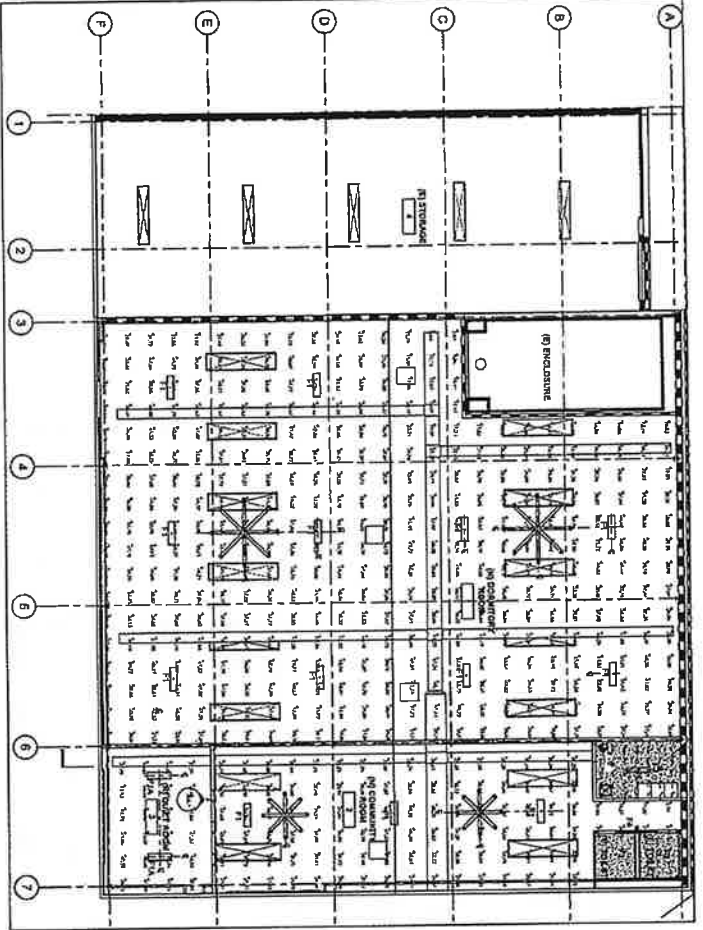
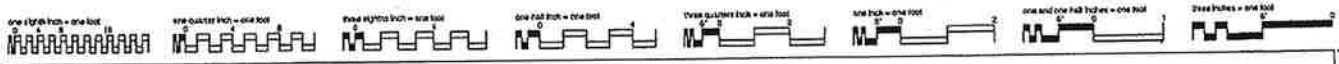

Foot Candle Levels		Foot Candle Levels		Foot Candle Levels	
Level	Area	Level	Area	Level	Area
1	1000	2	1000	3	1000
4	1000	5	1000	6	1000
7	1000	8	1000	9	1000

Foot Candle Levels		Foot Candle Levels	
Level	Area	Level	Area
10	1000	11	1000
12	1000	13	1000

Foot Candle Levels		Foot Candle Levels	
Level	Area	Level	Area
14	1000	15	1000
16	1000	17	1000

125 BAYSHORE BLVD. NAVIGATION CENTER

San Francisco Department of Public Works

BLDG. NO. 200

CLIENT PROJECT NO. 2000

HRA

HERZOG & RAUBER ARCHITECTS

1000 CALIFORNIA STREET, SUITE 1000

SAN FRANCISCO, CA 94108

TEL: 415.774.3000

E2.1FC

FOOT CANDLE LEVELS

REVISIONS

NO.	DATE	DESCRIPTION	BY
1	07/20	ISSUE FOR PERMIT	HERZOG

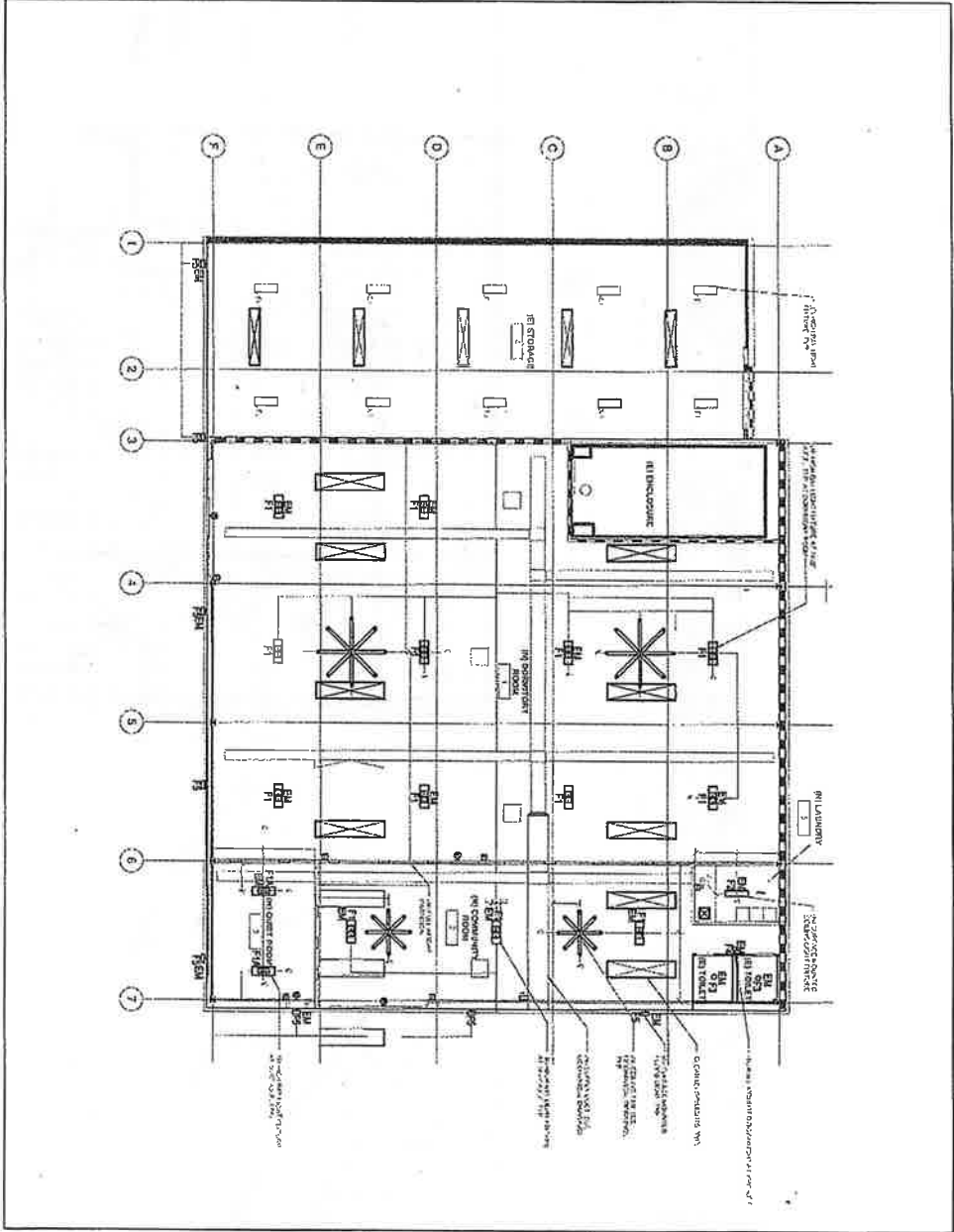

① LIGHTING PLAN
DATE: 12/1/10

KEYED NOTES:

- GENERAL SHEET NOTES:**
- A. ALL ELECTRICAL EQUIPMENT AND SERVICES ARE TO BE INSTALLED IN ACCORDANCE WITH THE NATIONAL ELECTRICAL CODE (NEC) AND ALL APPLICABLE LOCAL ORDINANCES.
 - B. PROVIDE COMPLETE AND DETAILED NOTES FOR ALL WORK.
 - C. CONDUCT VISUAL INSPECTION OF ALL WORK.
 - D. VERIFY ALL DIMENSIONS AND LOCATIONS OF ALL WORK.
 - E. PROVIDE ALL NECESSARY MATERIALS AND LABOR.
 - F. VERIFY ALL WORK IS COMPLETED AND SATISFACTORY.

WBE
 SIGHTING SERVICE - 11/10/10
 2810 BAYSHORE BLVD.
 SAN FRANCISCO, CA 94134
 TEL: 415.774.1111
 WWW.WBESIGHTING.COM

San Francisco Department of
 Public Works
 PUBLIC WORKS DEPARTMENT
 129 BAYSHORE BLVD.
 NAVIGATION CENTER



HRA
 HUMAN RESOURCE ASSOCIATES
 442 MARKET STREET, SUITE 1100
 SAN FRANCISCO, CA 94102
 TEL: 415.774.1111
 WWW.HRA.COM

NO.	DATE	DESCRIPTION	BY
1	12/1/10	ISSUED FOR PERMIT	JL
2	12/1/10	ISSUED FOR CONSTRUCTION	JL
3	12/1/10	ISSUED FOR AS-BUILT	JL
4	12/1/10	ISSUED FOR FINAL	JL

BAYSHORE BLVD.
 LIGHTING PLAN
 129 BAYSHORE BLVD.
 NAVIGATION CENTER
 SAN FRANCISCO, CA 94134
 DATE: 12/1/10
 DRAWN BY: JL
 CHECKED BY: JL
 PROJECT NO: 129B-10-001
 SHEET NO: E2.1

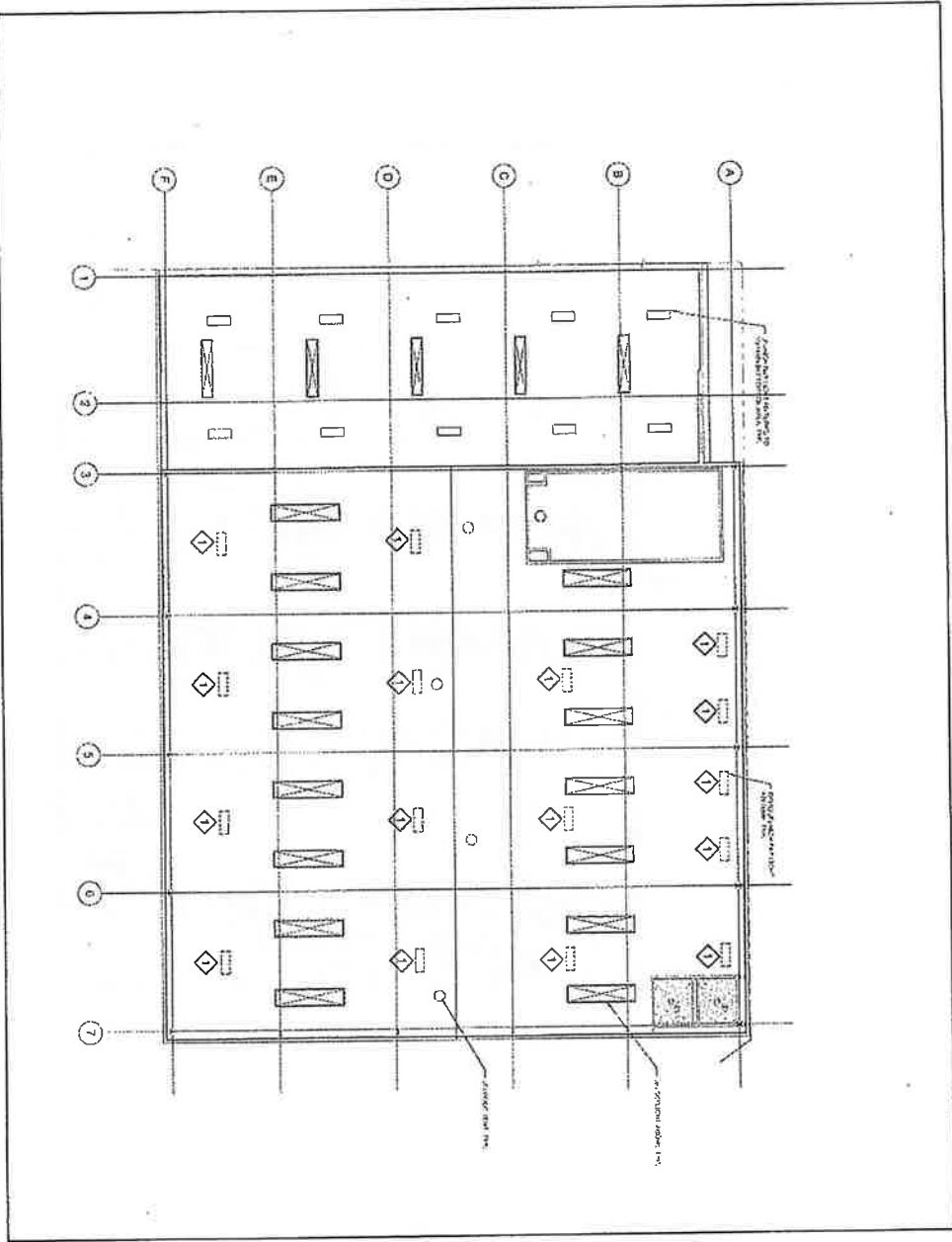

① LIGHTING DEMO PLAN
1/8" = 1'-0"

GENERAL SHEET NOTES:
 A. ALL ELECTRICAL EQUIPMENT AND SERVICES ARE EXCEPTED UNLESS OTHERWISE NOTED.
 B. SEE NEW DOCUMENTS FOR NEW WORK.
KEYED NOTES:
 ◆ ROOM AND ROOMS TO LIGHT FROM THIS ROOM OR DISCONNECT TO BE DETERMINED BY THE CONTRACTOR.



**125 BAYSHORE BLVD.
 NAVIGATION CENTER**
 San Francisco Department of
 Public Works
 ARCHITECT NO. 2008
 CIVIL PROJECT NO. 2008



HRA
 HUMAN RESOURCE ARCHITECTS
 1000 CALIFORNIA STREET, SUITE 100
 SAN FRANCISCO, CA 94109
 TEL: 415.774.8888
 WWW.HRAARCHITECTS.COM

NO.	DATE	DESCRIPTION	BY
1	08/20/08	ISSUE FOR PERMITTING	HW
2	08/20/08	ISSUE FOR PERMITTING	HW
3	08/20/08	ISSUE FOR PERMITTING	HW
4	08/20/08	ISSUE FOR PERMITTING	HW
5	08/20/08	ISSUE FOR PERMITTING	HW
6	08/20/08	ISSUE FOR PERMITTING	HW
7	08/20/08	ISSUE FOR PERMITTING	HW
8	08/20/08	ISSUE FOR PERMITTING	HW
9	08/20/08	ISSUE FOR PERMITTING	HW
10	08/20/08	ISSUE FOR PERMITTING	HW
11	08/20/08	ISSUE FOR PERMITTING	HW
12	08/20/08	ISSUE FOR PERMITTING	HW
13	08/20/08	ISSUE FOR PERMITTING	HW
14	08/20/08	ISSUE FOR PERMITTING	HW
15	08/20/08	ISSUE FOR PERMITTING	HW
16	08/20/08	ISSUE FOR PERMITTING	HW
17	08/20/08	ISSUE FOR PERMITTING	HW
18	08/20/08	ISSUE FOR PERMITTING	HW
19	08/20/08	ISSUE FOR PERMITTING	HW
20	08/20/08	ISSUE FOR PERMITTING	HW

BAYSHORE BLVD.
125 BAYSHORE BLVD.
NAVIGATION CENTER
 LIGHTING DEMO PLAN

E2.1D

DATE: 08/20/08
 SHEET NO.: 10

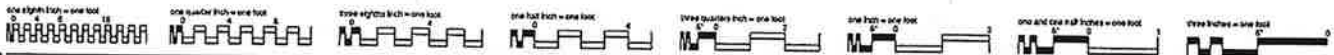

1 POWER & SIGNAL PLAN

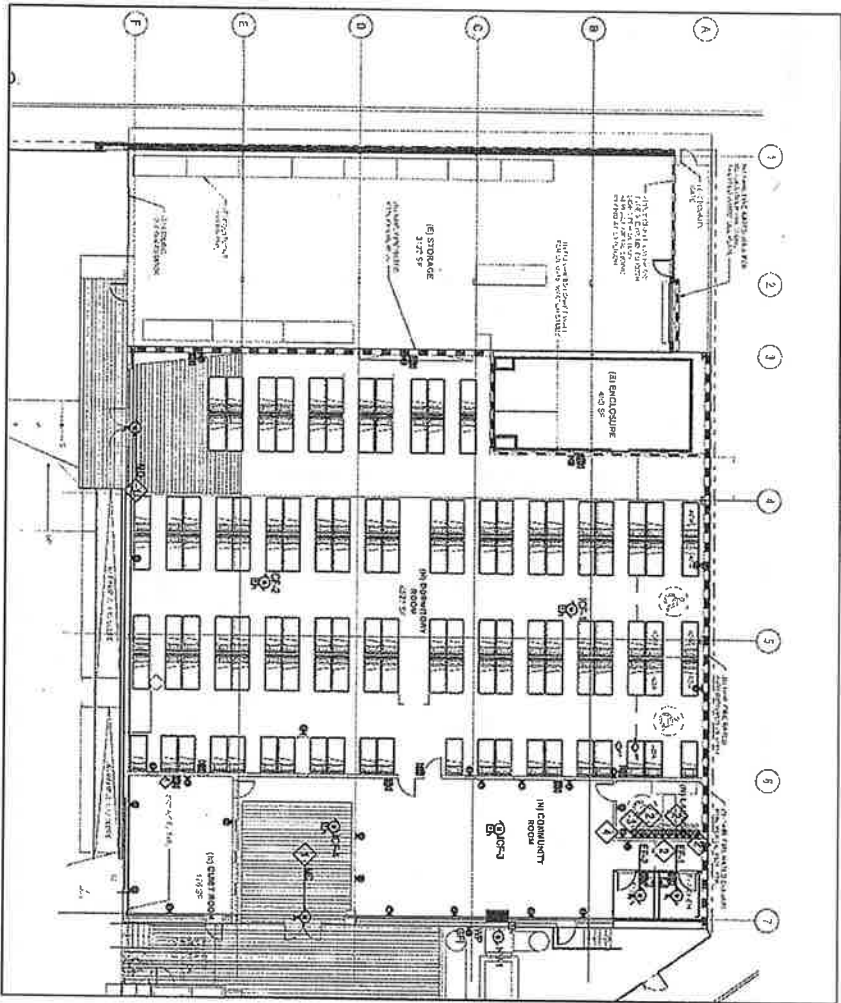

- GENERAL SHEET NOTES:**
- A. ALL SIGNAL, SECURITY AND SECURITY EQUIPMENT SHALL BE INSTALLED BY THE CONTRACTOR.
 - B. PROVIDE CABLE AND RISE FOR SIGNALING.
 - C. PROVIDE ALL PRECIPITATES TO PANEL LINE.
 - D. PROVIDE ALL SIGNALING EQUIPMENT TO PANEL LINE.
- KEYED NOTES:**
- ◇ AUTHORIZED REPRESENTATIVE CONTACTED FOR ALL SIGNALING INFORMATION.
 - ◇ SIGNALING EQUIPMENT - 10V, SIGNAL PANEL, 200V PANEL.
 - ◇ SWITCH - 200V, 200V, 200V, 200V.
 - ◇ SWITCH - 200V, 200V, 200V.

	<p>125 BAYSHORE BLVD. NAVIGATION CENTER</p> <p>San Francisco Department of Public Works</p> <p>San Francisco, CA 94102</p>		<p>CONSULTANTS:</p> <p>HRA</p> <p>125 BAYSHORE BLVD., SUITE 1200 SAN FRANCISCO, CA 94102 TEL: 415.774.1111 WWW.HRA.COM</p>	<p>PROJECT NO. 125BAYSHORE</p> <p>DATE: 12/15/11</p> <p>DESIGNED BY: [Name]</p> <p>CHECKED BY: [Name]</p> <p>SCALE: 1/8" = 1'-0"</p> <p style="font-size: 24pt; font-weight: bold;">E3.1</p>
--	--	--	---	--

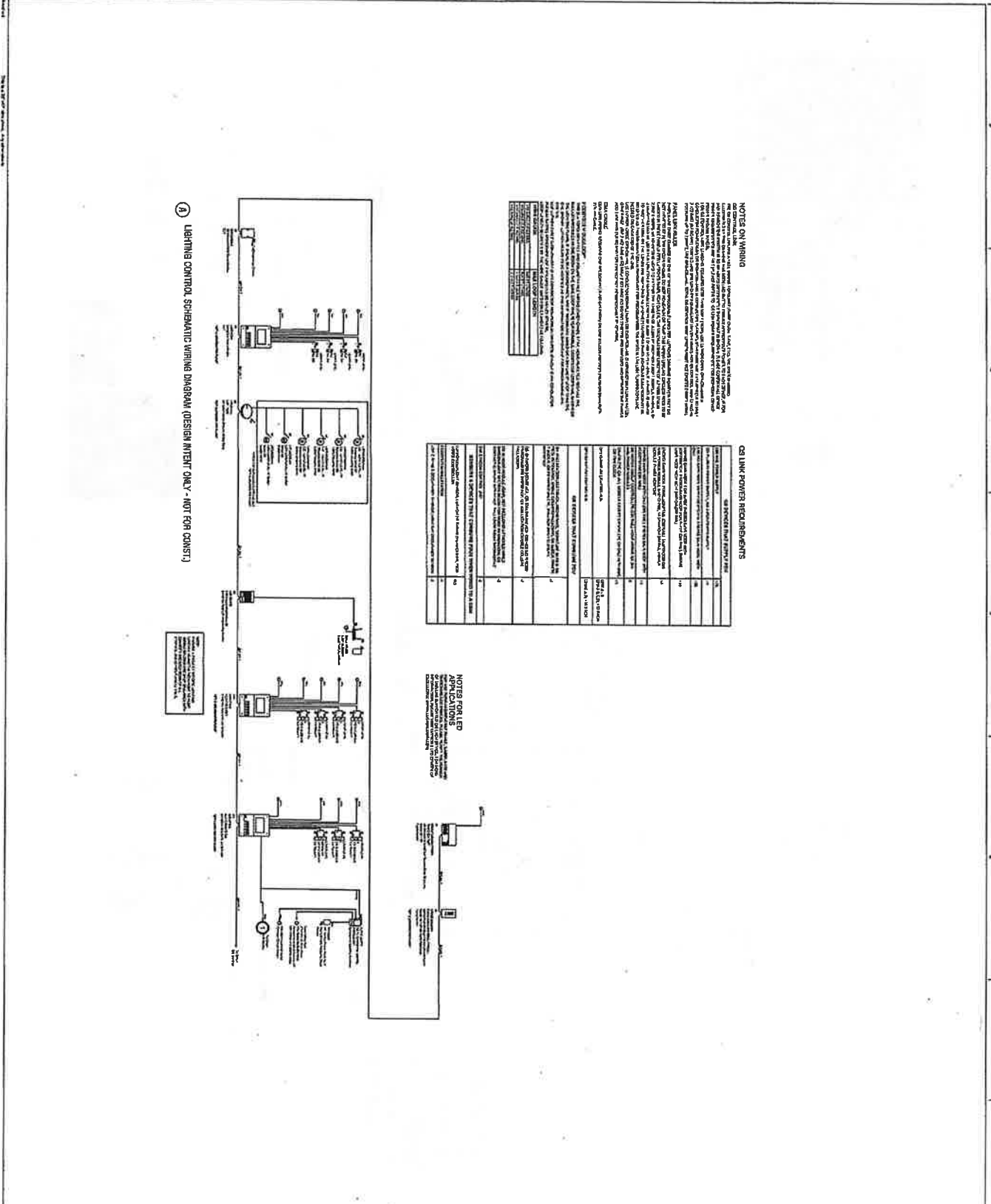
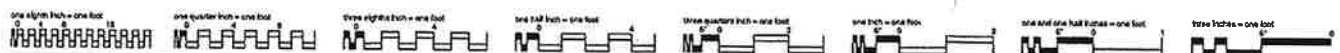

⑥ LIGHTING CONTROL SCHEMATIC WIRING DIAGRAM (DESIGN INTENT ONLY - NOT FOR CONSTRUCTION)

NOTES ON WIRING

1	120VAC
2	240VAC
3	120VAC
4	240VAC
5	120VAC
6	240VAC
7	120VAC
8	240VAC
9	120VAC
10	240VAC
11	120VAC
12	240VAC
13	120VAC
14	240VAC
15	120VAC
16	240VAC
17	120VAC
18	240VAC
19	120VAC
20	240VAC

CONTRACTOR'S REQUIREMENTS	DATE	BY
1		
2		
3		
4		
5		
6		
7		
8		
9		
10		
11		
12		
13		
14		
15		
16		
17		
18		
19		
20		
21		
22		
23		
24		
25		
26		
27		
28		
29		
30		

NOTES FOR USE APPLICATIONS

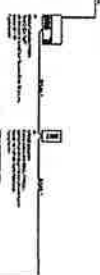



MEL
ARCHITECTURE • INTERIORS
2120 CALIFORNIA ST., SUITE 300
SAN FRANCISCO, CA 94109

**125 BAYSHORE BLVD.
NAVIGATION CENTER**

San Francisco Department of
Public Works

BLDG NO. 300
CLIENT PROJECT NO. 5000

CONSULTANTS



HRA
2120 CALIFORNIA ST., SUITE 300
SAN FRANCISCO, CA 94109
Tel: (415) 398-4800
Fax: (415) 398-4801

NO.	DATE	DESCRIPTION	BY

PROJECT NO. 5000
DRAWING NO. 5000-01
DATE PLOTTED: 10/24/2013 11:15 AM
BY: [unclear]
PLT: [unclear]

BAYSHORE BLVD.
PROJECT NO. 5000
DRAWING NO. 5000-01
DATE PLOTTED: 10/24/2013 11:15 AM
BY: [unclear]
PLT: [unclear]

JERROLD AVE.

DRAWING TITLE
**LIGHTING CONTROL
DIAGRAM**

DRAWING NO.
E6.1

THE INFORMATION CONTAINED ON THIS DRAWING IS FOR THE USE OF THE CLIENT ONLY. IT IS THE CLIENT'S RESPONSIBILITY TO VERIFY THE ACCURACY OF THE INFORMATION AND TO PROTECT THE INFORMATION FROM UNAUTHORIZED DISCLOSURE.

EXHIBIT B

**NOTICE OF COMMENCEMENT DATE, RENT COMMENCEMENT DATE AND
LEASE EXPIRATION DATE**

[Date]

Mr. John Updike
Director of Property
Real Estate Division
City and County of San Francisco
25 Van Ness Avenue, Suite 400
San Francisco, California 94102

RE: Acknowledgement of Commencement Date, Lease Between _____
(Landlord), and the CITY AND COUNTY OF SAN FRANCISCO (Tenant), for premises
known as _____ located at _____

Dear Mr. Updike:

This letter will confirm that for all purposes of the Lease, the Commencement Date (as defined in Section 3.2 of the Lease) is _____, 20__; the Rent Commencement Date (as defined in Section ___ of the Lease) is _____, 20__; and the Lease Expiration Date is _____, 20__.

Please acknowledge your acceptance of this letter by signing and returning a copy of this letter.

Very truly yours,

By: _____

Title: _____

Accepted and Agreed:

By: _____

John Updike
Director of Property

Dated: _____

EXHIBIT C -1

LANDLORD'S DISCLOSURES REGARDING ENVIRONMENTAL REPORTS,
DOCUMENTS, AND COMMUNICATIONS

[TO BE COMPLETED]

Phase I Environmental

Phase I has
been received

Jeff

6. Disposal Upon Lease Termination. At the expiration or earlier termination of the Lease, City, at its sole cost and expense, shall: (i) remove and dispose off-site any drums, containers, receptacles, structures, or tanks storing or containing Hazardous Materials (or which have stored or contained Hazardous Materials) and the contents thereof; (ii) remove, empty, and purge all underground and above ground storage tank systems, including connected piping, of all vapors, liquids, sludges and residues; and (iii) restore the Premises to its original condition. Such activities shall be performed in compliance with all Environmental Requirements and to the satisfaction of Landlord. Landlord's satisfaction with such activities or the condition of the Premises does not waive, or release City from, any obligations hereunder.

EXHIBIT C -2

HAZARDOUS MATERIALS LIST

[TO BE COMPLETED]

1. Permitted Hazardous Materials and Use.

City has requested Landlord's consent to use the Hazardous Materials listed below in its business at the Premises (the "Permitted Hazardous Materials"). Subject to the conditions set forth herein, Landlord hereby consents to the Use (hereinafter defined) of the Permitted Hazardous Materials. Any Permitted Hazardous Materials on the Premises will be generated, used, received, maintained, treated, stored, or disposed in a manner consistent with good engineering practice and in compliance with all Environmental Requirements.

Permitted Hazardous Materials (including maximum quantities):

- 1. None
 - 2. None
 - 3. None
 - 4. None
 - 5. None
- JK

The storage, uses or processes involving the Permitted Hazardous Materials (the "Use") are described below.

- 2. **Use [If limited to receiving and storage, so specify]:** Cleaning, storage of vehicles, routine repairs and maintenance, painting, and operation of equipment.
- 3. **No Current Investigation.** City represents and warrants that it is not currently subject to an inquiry, regulatory investigation, enforcement order, or any other proceeding regarding the generation, use, treatment, storage, or disposal of a Hazardous Material.
- 4. **Notice and Reporting.** City immediately shall notify Landlord in writing of any spill, release, discharge, or disposal of any Hazardous Material in, on or under the Premises or the Property. All reporting obligations imposed by Environmental Requirements are strictly the responsibility of City. City shall supply to Landlord within 5 business days after City first receives or sends the same, copies of all claims, reports, complaints, notices, warnings or asserted violations relating in any way to City's use of the Premises.
- 5. **Indemnification.** City's indemnity obligation under the Lease with respect to Hazardous Materials shall include indemnification for the liabilities, expenses and other losses described therein as a result of the Use of the Hazardous Materials or the breach of City's obligations or representations set forth above. It is the intent of this provision that City be strictly liable to Landlord as a result of the Use of Hazardous Materials without regard to the fault or negligence of City, Landlord or any third party, except to the extent any spill, release, discharge, or disposal is caused by the willful misconduct of Landlord.

EXHIBIT D

Intentionally Deleted

EXHIBIT E

LEASEHOLD IMPROVEMENTS WORK LETTER

This Work Letter is part of the Industrial Lease dated for reference purposes as of February 12, 2018 (the "Lease"), executed concurrently herewith, by and between W.Y.L. Orion Properties, LLC, a California limited liability corporation, as Landlord, and the City and County of San Francisco, as Tenant, covering certain premises described in the Lease. All terms that are capitalized but not defined herein shall have the same meanings given to them in the Lease.

In addition to the provisions of Section 6 of the Lease, the following provisions shall apply.

General Conditions. The performance of all Leasehold Improvement Work by Landlord shall be subject to the following terms and conditions:

i. All of the Leasehold Improvement Work and Leasehold Improvement Work shall be performed in compliance with all laws, codes, regulations and building requirements (collectively, "Laws") bearing on such construction, including but not limited to any requirements of the Regional Water Quality Control Board or other regulatory agency related to the disturbance of soils or other ground disturbing activity;

ii. Without limiting the foregoing, the construction of the Leasehold Improvements shall comply with all requirements of the Americans With Disabilities Act of 1990 and Title 24 of the California Code of Regulations and all other applicable federal, state, local and administrative laws, rules, regulations, orders and requirements intended to provide equal accessibility for persons with disabilities (collectively, "Disabled Access Laws"), and with City's work plan for accessibility improvements; and

iii. Landlord and its Contractor shall be responsible for all required insurance. Contractor must name City as additional insured/loss payee under all insurance required under its contract with Landlord and, before commencing construction, Landlord must provide Contractor's certificates of insurance and copies of all endorsements to City evidencing the same.

EXHIBIT F

FORM OF LANDLORD CONSENT AND WAIVER AGREEMENT

CONSENT AND WAIVER AGREEMENT

THIS CONSENT AND WAIVER AGREEMENT (this "Agreement") is made and entered into as of the _____ day of _____, 20____ by and between _____ ("Landlord"), and _____ ("Vendor").

WITNESSETH:

Whereas, Landlord and _____ ("Tenant") have entered into that certain lease dated _____, 20__ (together with any amendments, modifications, or extensions, the "Lease") pursuant to which Tenant is leasing certain premises located at _____ ("Premises") from Landlord;

Whereas, Vendor is [leasing][supplying] the materials described in the attached Schedule 1 the "Personal Property") to Tenant at the Premises pursuant to _____ ("Supply Agreement"), Tenant has requested, and Landlord has agreed, subject to certain conditions, to the following matters.

NOW, THEREFORE, in consideration of the mutual covenants contained herein, and for other consideration, the receipt and sufficiency of which is hereby acknowledged, Landlord and Vendor hereby agree as follows:

1. Notwithstanding any provision of the Lease which may exist or any statutory lien in favor of the Landlord, any lien that Landlord might have to the Personal Property shall be subordinate and subject to the lien that Vendor has in the Personal Property pursuant to the Supply Agreement ("Vendor's Lien").

2. During the term of the Lease ("Term"), Landlord agrees not to interfere with Vendor, or Vendor's agents, in Vendor's efforts to assemble, remove or sell the Personal Property located on the Premises or otherwise hinder Vendor's actions in enforcing Vendor's Lien (including without limitation, the inspection of the Personal Property by Vendor or Vendor's agents). Notwithstanding the foregoing, if and when Vendor receives the Landlord Notice (as defined in Paragraph 3 below), the terms set forth in Paragraph 4 shall prevail.

3. If Landlord takes action to terminate the Tenant's possession of the Premises or the Lease prior to the expiration of the Term, Landlord agrees to provide Vendor with written notice upon the completion of such action by Landlord (the "Landlord's Notice") to the Vendor in person or by a commercially-recognized, next business day courier service at the following address:

4. After Landlord has delivered the Landlord's Notice to Vendor, Landlord agrees to provide Vendor with access to the Premises for the purpose of collecting, removing and selling the Personal Property on the condition that: (i) Vendor hereby agrees that it shall not enter, occupy and/or possess the Premises for a period beyond thirty (30) days after Vendor's receipt of the Landlord's Notice ("Disposition Period"), and (ii) Vendor (a) will pay to Landlord the basic rent due under the Lease, pro-rated on a per diem basis determined on a 30-day month, for each day that occurs between the fifth (5th) day immediately following Vendor's receipt of the Landlord's Notice and the day that Vendor removes the Personal Property from the Premises, and (b) shall retain liability and property insurance coverage in the same forms and amounts as required by Tenant under the Lease at all times that Vendor is on the Premises to remove the Personal Property. If any injunction or stay is issued (including automatic stay due to a bankruptcy proceeding) that prohibits (Y) Vendor from removing the Personal Property, and (Z) Landlord from retaking possession of the Premises, the commencement of the Disposition Period will be deferred until such injunction or stay is lifted or removed as to the Landlord and Vendor.

5. During any period of Vendor's entry on the Premises, Vendor agrees to allow Landlord full access to the Premises for the purposes of marketing the Premises for lease and making repairs and improvements to the Premises.

6. Except for matters arising from the gross negligence or willful misconduct of Landlord, and to the extent permitted by law, Vendor agrees to indemnify, defend and hold harmless Landlord, and Landlord's agents, employees and contractors, from and against any and all losses, liabilities, damages, costs and expenses (including attorneys' fees) resulting from claims by third parties for injuries to any person and damage to or theft or misappropriation or loss of property occurring in or about the Premises is located and arising from the entry, use or occupancy of the Premises by Vendor or from any activity, work, or thing done, permitted or suffered by Vendor in or about the Premises when on the Premises or due to any other act or omission of Vendor, its invitees, employees, contractors and agents when on the Premises. The furnishing of insurance required hereunder shall not be deemed to limit Vendor's obligations under this Paragraph.

7. Vendor hereby agrees that Lender shall be required to repair any damage to the Premises caused by Vendor, or Vendor's agents, during the period in which Vendor (or its agents) enters or is in possession of the Premises (ordinary wear and tear excluded). Vendor shall not have any duty or obligation to remove or dispose of any Personal Property left on the Premises by Tenant.

8. Neither Vendor, nor Vendor's agents, shall hold any public auction or public sale of the Personal Property on the Premises. Landlord shall permit Vendor to hold a private sale of the Personal Property on the Premises.

9. This Agreement shall in all respects be a continuing agreement and shall expire upon the earlier of (i) the expiration of the Disposition Period, or (ii) Tenant's satisfaction in full of Tenant's obligations under the Agreement, as evidenced by written release or termination by the Vendor.

IN WITNESS WHEREOF, this Agreement has been executed and delivered by the Vendor and the Landlord as of the day and year first written above.

VENDOR:

By: _____

Name: _____

Title: _____

LANDLORD:

By: _____

Name: _____

Title _____

EXHIBIT G

FORM OF TENANT'S ESTOPPEL CERTIFICATE

TO: _____

Attention: _____

RE: The Lease (defined below), at 125 Bayshore Boulevard, San Francisco, California (the "Premises")

City and County of San Francisco, a municipal corporation (the "Tenant"), hereby certifies to _____ and its successors and assigns (the "Interested Person"), and to _____, a _____ (the "Landlord"), the following information with respect to that certain Lease, dated _____, 2018 (the "Original Lease," and together with any amendments to or modifications of the same, are collectively, the "Lease,") and Tenant agrees that Landlord, Interested Person may rely upon the same:

1. The Original Lease is in full force and effect and has not been modified or amended *[except as follows: _____]*.
2. Tenant has accepted possession of and occupies the Premises under the Lease. The term of the Lease commenced on _____ and expires on _____. Tenant has _____ option(s) to extend the Term for _____ years.
3. To Tenant's knowledge, there exists no breach or default, nor state of facts nor condition which, with notice, the passage of time, or both, would result in a breach or default on the part of either Tenant or Landlord. *[except as follows: _____]*.
4. All fixed base rental has been paid to the end of the current calendar month, which is _____, and no rent under the Lease had been paid more than one month in advance of its due date. Current monthly fixed based rental for the Premises is \$ _____. Landlord has not agreed to grant Tenant any free rent or rent rebate. *[except as follows: _____]*.
5. The Lease provides for Tenant's right to terminate the Lease pursuant to Section 23.23 of the Lease.
6. Landlord is presently holding a security deposit of \$ _____.
7. There are no unfinished tenant improvements required to be completed by Landlord as of the date hereof or any outstanding and unpaid tenant improvement allowances owing to Tenant

as of the date hereof. *[except as follows:*

_____].

8. Tenant recognizes and acknowledges it is executing this Tenant Estoppel Certificate with the intent that Landlord and Interested Person may rely hereon. As used herein Tenant's "knowledge" means the actual knowledge as of the date hereof of Director of Property, without duty of investigation or inquiry.

10. Nothing in the Tenant estoppel letter amends or modifies the terms of the Lease.

Dated: _____, 20__

Very truly yours,

City and County of San Francisco,
a municipal corporation

By: _____

JOHN UPDIKE

Director of Property

