



CITY AND COUNTY OF SAN FRANCISCO
 San Francisco Municipal Transportation Agency
 Request for Proposals
 THE PROCUREMENT OF
 30-Foot, 40-FOOT AND 60-FOOT LOW FLOOR
 DIESEL HYBRID COACHES

Proposal Section	Title	Bid Submission Requirements
3-F	Furnishings	<ol style="list-style-type: none"> 1) How are the door edges sealed to keep water and drafts out of the bus? 2) Describe the thickness and quality of all windows glass used. 3) Explain how window hardware is non-corroding. 4) Describe accessibility of the windshield wiper motor and washer equipment. 5) Describe the design of the interior lighting system, including compatibility of ballasts and lamps. 6) Which exterior lamps do you prefer to use and why? 7) Where is the rear route number sign located and how is maintenance accessibility accomplished? 8) Describe outside access panels, including opening assists, latches and corrosion proof features. 9) Describe all floor hatches, their latches and the treatment of the opening in the floor? 10) Describe the design effort to ensure maximum readability of the LED signs by intending passengers. Show how a 60 inch (152.4 cm) tall person can easily read the front and side signs while standing 36 inches (91.4 cm) away from the bus at various angles to the vertical centerline of the bus. 11) Describe the details of the passenger signal system. 12) To what extent are flush mounted exterior lights utilized, and where?

Please find attached the information which corresponds to Section 3-F. Door panels are sealed into the door portal by means of weather seals that but the door frame on the outboard side of each panel. The door panel leading edges are sealed by means of an overlapping seal. Each door panel is also equipped with a lower brush that closes the space between the bottom of the door panel and the top of the step. Another brush is blocking the space between the shelf plate and the tops of the door panels. Please refer to the attached Sales Information Bulletin for additional information regarding the proposed doors.

New Flyer's standard product offering is Arow Global (Stormtite) windows which offer 6mm, laminated window glass. Arow Global windows offer a superior fit and finish to competitive products and are very robust, meeting and exceeding customer and government requirements for safety, durability, serviceability and corrosion protection. Please refer to the attached Sales Information Bulletin for additional information regarding the proposed windows. Arow Global uses a high-quality anodized aluminum finish and stainless-steel hardware to enhance long-term durability and corrosion protection.

The windshield wiper motors are mounted to brackets located behind access panels below the windshield. The windshield washer is controlled by the wiper/washer control knobs, which are located on the instrument panel. When the control knob is pressed the washer bottle motor operates and causes washer fluid to be sprayed onto the windshield. The motor is externally mounted beside the washer bottle. The motor stops operating when the switch is released.



CITY AND COUNTY OF SAN FRANCISCO
San Francisco Municipal Transportation Agency
Request for Proposals
THE PROCUREMENT OF
30-Foot, 40-FOOT AND 60-FOOT LOW FLOOR
DIESEL HYBRID COACHES

All buses come with Genuine New Flyer Interior lighting, we use the latest LED technology available, the LED's are housed in silicone for lower operating temperatures resulting in a longer life, the life expectancy is 100,000 hours and are warranted for 12 years. Please refer to the attached Sales Information Bulletin for information regarding the interior lighting system on the proposed vehicle.

New Flyer uses a combination of Dialight exterior LED lights, New Flyer branded lights and Headlights provided by JW Speaker. These are New Flyer preferred suppliers as they offer exceptional customer support.

The rear route sign is located and installed at the top of the rear crown. It is easily accessible and is easily maintenance by simply removing the screws that attach the sign to the rear of the bus. Please refer to the attached pictures.

Please refer to the attached Sales Information Bulletin regarding all exterior access panels and functions.

We have attached floor drawings that depict the details of our floor hatch and the latch systems used.

All of the surface (Top row to Bottom Row) of the dot matrix signs shall be visible to a person who is 5'3"(160 cm) tall. For further details on angles, specifications and ADA compliance please refer to our attachment for Destination Signs.

We have attached our drawings of the location of all passenger stop requests including pushbuttons and pull-cords.

Please see attached pictures to view the use of all flush mounted exterior lighting.

SALES INFORMATION BULLETIN

#490-001 | Model: Xcelsior | Lengths: All | Propulsions: All

Front Entrance Door

Product Features

The front entrance door is a Vapor Slide Glide door operating in such a manner as to offer optimum height and width of opening by sliding the door panels open @ 90° to the vehicle body while using very little space for movement for the operating mechanism. The panels are Ameriview full glazing panels consist of extruded aluminum pieces, the interior and exterior surface polyester powder coated. The slide glide door panels are affixed to the post and arm assemblies by upper and lower arm rod ends. The door hinges are sealed rod ends.

The shaft and arm assemblies are attached to the door panels and held in place by upper and lower bearings. The upper bearings are seated in the door mechanisms base plate assembly and hold the weight of the shafts and doors. The lower bearings are attached to the floor to control lateral movement. These components function together as part of the door assembly to open and close the doors

It is air operated by a minimum 85 psi air pressure from the vehicle accessory tank. The door system consists of a differential door motor mounted horizontally on a shelf plate above the door panels. The motor, when operated, causes the rod actuating assembly to apply torque to the two hinge posts, and arm assemblies, which are mounted vertically from the base of the door portal up through the shelf plate, one on each side of the door opening.

The five positions controller located on side console controls the related door functions. The door is held in the open or closed position by means of air pressure. When air pressure is not present, the doors will remain open or closed and may be pushed to either position. New Flyer standard for door actuation is a driver controlled function. The door panels are sealed into the door portal by means of weather seals that abut the door frame on the outboard side of each panel. The door panel leading edges are sealed by means of an overlapping seal. Each door panel is also equipped with a lower brush that closes the space between the bottom of the door panel and the top of the step. Another brush is blocking the space between the shelf plate and the tops of the door panels.



Specifications

Manufacturer	Vapor
Model	Slide Glide
Type	Pneumatic (air)
Controller	5-position electric control
Open position	90°
Operation	Driver Controlled
Opening between panels	36.8" (934.7 mm)
Clear Opening	33.8" (858.5 mm)
Height	77.3" (1963.5 mm)

SALES INFORMATION BULLETIN

Door Glass

Front door comes standard with full glazing, green tint, 72% light transmittance.

Entrance Door Switch Plate & Limit Switches

The door mechanism is equipped with two limit switches (LS1 & LS2) that are mounted on the inboard face of the door motor plate. The switches are mounted together on a common support plate.

Opening or closing the door causes the gear rack on the door motor piston to drive the output shaft gear and rotate the output shaft (teeter) lever. An actuating cam is attached to the output shaft lever. As the door approaches the fully opened position, the actuating cam will actuate the LS2 limit switch. This switch is referred to as the 85° limit switch and is used by the vehicle Multiplexing System to recognize a "door open" condition. As the door approaches the fully closed position, the actuating cam will actuate the LS1 limit switch. This switch is referred to as the 5° limit switch and is used by the vehicle multiplexing system to recognize a "door closed" condition.

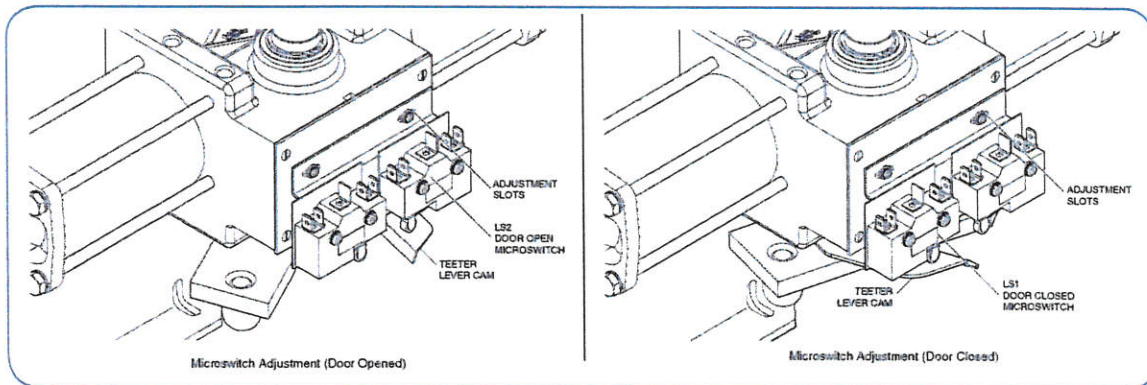

Emergency Air Release Valve

A red handled rotary valve is used to pressurize and vent the air supply from the lines and air cylinder of the door system. The valve can quickly be used to exhaust the air from the door circuit, should an emergency arise, or during service procedures. The location of the emergency dump valve is beside the door behind a frangible panel marked for emergency use.

The door manual control Valve located near the driver controls may also be used by the driver or service personnel to perform the same function without the necessitating the opening of the hinged access door.

SALES INFORMATION BULLETIN

#460-002 | Model: Xcelsior® | Lengths: All | Propulsions: All

Arow Global Windows

Product Features

Arow Global (Stormtite) has multiple window styles available including egress, non-egress, transom, stationary, horizontal mullion and driver's slide. Each style is available in both flush and non-flush glass. The windows are built from laminated glass with additional options to reduce solar loading. Multiple vandalism-protection options are also available including acrylic liners, single- and multi-layer films.



Benefits

- Arow Global is a long-standing supplier in the transit market, manufacturing transit windows for over 30 years with an industry reputation for quality, durability, dependability and service.
- Arow Global windows offer a superior fit and finish to competitive products and are very robust, meeting and exceeding customer and government requirements for safety, durability, serviceability and corrosion protection.
- Arow Global uses a high-quality anodized aluminum finish and stainless-steel hardware to enhance long-term durability and corrosion protection.

Available Options

For ridership, Arow Global's windows have easy, user-friendly operation whether it be in the latches to open the transom windows or the large, bright red egress handles to open the windows in an emergency situation. For mechanics, Arow Global's windows offer straight-forward operation and service with uncomplicated procedures for daily operation and repair.

Warranty

Arow Global's easily serviceable windows are backed by a two-year warranty and a dedicated, friendly and readily accessible support team. As noted above, Arow Global's service goes beyond the warranty period to ensure customer satisfaction with our products.

Service/Repair

Arow Global is noted for its rapid, exceptional customer service and support. They are quick in response to inquiries rendering onsite assistance service in order to resolve issues. Arow Global works closely with both our clientele and Arow Global customers in order to ensure that service parts are available in a timely manner to minimize downtime. Service specialists provide a detailed checklist for each window assembly and service instructions to assist in rework or repair. Arow Global's customer service extends well beyond the warranty period and is provided for the life of the bus.

Testing

Arow Global's windows have been thoroughly tested, meeting and exceeding customer and government requirements for safety, durability, serviceability and corrosion protection. With Arow Global's in-house test capabilities, windows have been tested for:

- FMVSS 217 government requirements
- Slam/Cycle durability testing
- Corrosion and weathering testing
- Vehicle level vibration
- Water leaks



NEW FLYER



XCELSIOR
BETTER BY DESIGN

SALES INFORMATION BULLETIN

#277-001 | Model: XcelSior | Lengths: ALL | Propulsions: ALL

Genuine New Flyer Interior LED Lighting

Product Features

New Flyer Interior LED Lighting uses the newest technology available:

- 1/8th watt LEDs arranged in a single row with .88" (2.24 cm) spacing and high yield binning
- LEDs are housed in silicone for lower operating temperatures resulting in a longer life
- Larger area for ducts provides improved air circulation
- Integrated styling to match bus interior
- Made with durable pultruded fiberglass, powder-coated aluminum and polycarbonate lensing
- Easy to maintain
- Best-in-Class Warranty

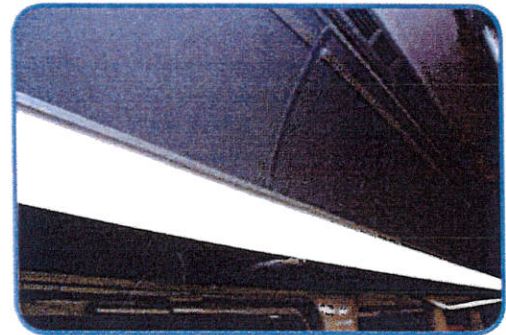

Benefits

1/8th watt LEDs

- Newest technology available to transit – provides more light output while consuming less power and longer life
 - Increased efficiency with lower wattage LEDs
 - 1/8th watt LEDs are proven in automotive applications and LED monitors
- New design with a single row eliminates hot spots, provides consistent smooth coverage and the high number of LEDs per board reduces the risk of dark spots if an LED outage occurs
- High-yield binning ensures consistent color within the bus and throughout bus fleets
- Availability in various lengths ensures lighting can be installed throughout entire bus

Integrated styling designed to match bus interior

- Less visible hardware for a streamlined appearance
- Seamless lenses up to 30 feet in length (9 m)
- Integrated ceiling stanchion track for mounting curved seamless stanchions

Larger Ducting

Compact LED lighting allows 125 square inches in cross section for best-in-class HVAC airflow which meets the ThermoKing recommendation (ThermoKing recommends between 110 and 150 square inches (710 and 968 cm²) for optimal air circulation).

SPECIFICATIONS

LED Power	1/8 th watt
Housing	Silicon
Life Expectancy	100,000 hours
Ducting area	125 in ² (807 cm ²)
Lens Material	Polycarbonate
Maximum Lens length	30 feet (9 m)
Material	Powder-coated aluminum speaker panels
LED Circuit Board Length	Various lengths
Warranty	12 years



NEW FLYER



XCELSIOR
BETTER BY DESIGN

SALES INFORMATION BULLETIN

Silicone-Packaged LEDs

- The LED is packaged in Silicone resulting increased color stability
- LED life expectancy exceeds 100,000 hours
- LEDs have a 40% reduction in power consumption

Materials Used

- Materials selected are integrated with interior styling
- Advertising panels are pultruded fiberglass, which is durable and light weight (Docket 90 compliant)
- The speaker panels are powder-coated aluminum, which has a textured finish
 - Aesthetically pleasing and more easily hides scratches
 - Better dent resistance than Dibond aluminum

Ease of Maintenance

- LED circuit boards can be individually replaced as opposed to replacing a six-foot light
 - Less downtime
 - Faster repair times
 - Lower costs for repairs

Available Options

Dimmer and Other Lighting Control Features are also available:

- The ability to dim the lights reduces the glare on windshields, which allows the operators to leave the lights on for passengers (Current practice is to extinguish fluorescent lights to reduce glare)
- Light levels can be automatically adjusted based on ambient light, which prolongs battery life and reduces power consumption
 - Ambient light sensing is managed with software and multiplexing, eliminating costly control modules
- Touch screen modules allow transit systems to adjust, control and customize the system features to meet unique needs

Warranty

New Flyer Interior LED lights have an industry-leading 12-year warranty on both the lights and parts for the fixtures.

Testing

Testing complies with the Standard Bus Procurement Guidelines. Test reports are available upon request.



SALES INFORMATION BULLETIN

#420-001 | **Model:** Xcelsior | **Lengths:** All | **Propulsions:** Diesel, Hybrid

Exterior Access Doors

Product Features

All of our Xcelsior products provide the required access doors to ensure proper service, inspection and accessibility to the major components and systems. The access doors have various locks such as square key quarter turn latches, gas springs or steel springs to hold the doors in the required position for service and bus operation. The doors are designed to be fully functional while enhancing the overall appearance of the product. The smaller spring-loaded access doors, along with the engine compartment door, have built-in handles to allow for ease of opening.



ACCESS DOORS

1	Defroster and Wiper Motor
2	Windshield Washer Fill Bottle
3	Electrical Side Console
4	Coolant (Surge) Tank
5	Radiator
6	Selective Catalytic Reduction (SCR)
7	Curbside Upper Corner Pillar
8	Diesel Exhaust Fluid (DEF) Fill
9	Streetside Upper Corner Pillar
10	Engine
11	Curbside Engine
12	Battery Disconnect Switch
13	Battery
14	Diesel Fuel Fill



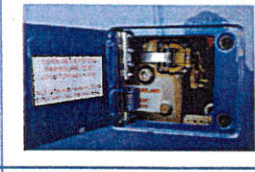
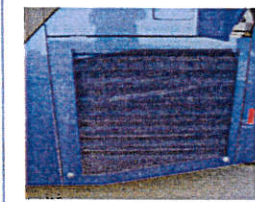
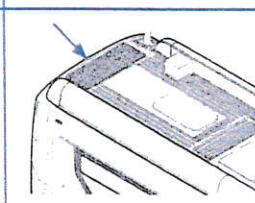

SALES INFORMATION BULLETIN

#420-001

	Access Door	Material	Location	Design Features	Access To	Dimensions	Image
1	Defroster and Wiper Motor	Fiberglass	In the front of the vehicle below the windshield	It has two hinges on its upper edge, is held open by two gas struts, and is held closed by two square key quarter turn latches	Defroster assembly and wiper motors	65.8" W 24.9" H	
2	Windshield Washer Fill Bottle	Aluminum	Inset into the Electrical Side Console Access Door	A center spring allows the door to remain open and a magnetic latch holds the door closed	Windshield washer fill bottle	5.12" W 4.25" H	
3	Electrical Side Console	Aluminum	Under the driver's window	It is held open by two gas struts and held closed by two square key quarter turn latches	Front electrical panel, circuit breakers and fuses	42.2" W 30.6" H	
4	Coolant (Surge) Tank	Aluminum	Above the radiator access door	Spring loaded to allow it to remain open or closed	Coolant (Surge) Tank	9.1" W 7.3" H	
5	Radiator	Aluminum with a corrugated stainless steel grill	Street side at the rear of the vehicle	Held open by two gas struts and held closed by two square key quarter turn latches. Provides maximum surface area for airflow and eliminates clogging	Radiator, charge air cooler and oil cooler	48.6" W 41.8" H	
6	Selective Catalytic Reduction (SCR)	Stainless Steel Perforated Panel	Roof-mounted at the rear of the vehicle	Held in place with screws at the rearward edge and bolts at the forward edge	Exhaust system components and plumbing	87" W 28.2" H 17.6" D	



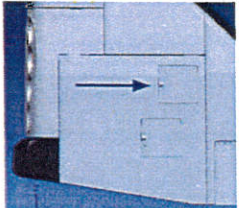

SALES INFORMATION BULLETIN

#420-001

	Access Door	Material	Location	Design Features	Access To	Dimensions	Image
7	Curbside Upper Corner Pillar Access	Fiberglass	Curbside at the rear of the vehicle.	Secured with two square-key quarter-turn latches at the rear of the vehicle They are hinged and pivot 90° outward. Two over center springs permit the doors to remain open for servicing	Air intake grill, air cleaner	21.2" W 60.5" H	
8	Diesel Exhaust Fluid (DEF) Fill	Aluminum	The manual fill door is set in the lower curbside engine door	Held open and closed by two flip-open doors using a gas strut	DEF Tank	11.0"W 10.50" H	
9	Street-side Upper Corner Pillar	Fiberglass	Street side at the rear of the vehicle	Secured with two square-key quarter-turn latches at the rear of the vehicle They are hinged and pivot 90° outward. Two over center springs permit the doors to remain open for servicing	Exhaust system	21.2" W 60.5" H	
10	Engine	Fiberglass	Rear of the vehicle	Secured with two square-key quarter-turn latches. Uses scissor style hinge allowing opening angle of 143°. Two over center springs permit the doors to remain open for servicing.	Engine	80.2" W 35.8" H	

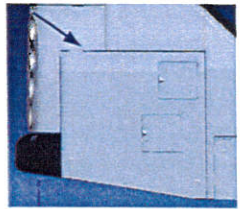
SALES INFORMATION BULLETIN

#420-001

	Access Door	Material	Location	Design Features	Access To	Dimensions	Image
11	Curbside Engine	Aluminum	Curbside, rear of the vehicle	Held open with two gas struts and is held closed by two square key quarter turn latches	Battery disconnect switch and the fuse box	41.1" W 13.8" H	
12	Battery Disconnect Switch Door	Aluminum	In the curbside engine access door	Operated by one gas strut to allow the door to remain open or closed	Access to the disconnect switch without opening the larger door	11.0" W x 11.48" H	
13	Battery	Aluminum	Curbside behind the rear wheel	Held open one gas strut and held closed by two square key quarter turn latches	Batteries	31.4" W x 17.6" H	
14	Diesel Fuel Fill	Aluminum	Near the center of the vehicle, rear of the exit door and forward of the rear wheel	Spring loaded to allow it to remain open or closed	Fuel fill	11.5" W x 11.9" H	

TwinVision Full Color Sign System for San Francisco MUNI Buses

Package Dimensions:

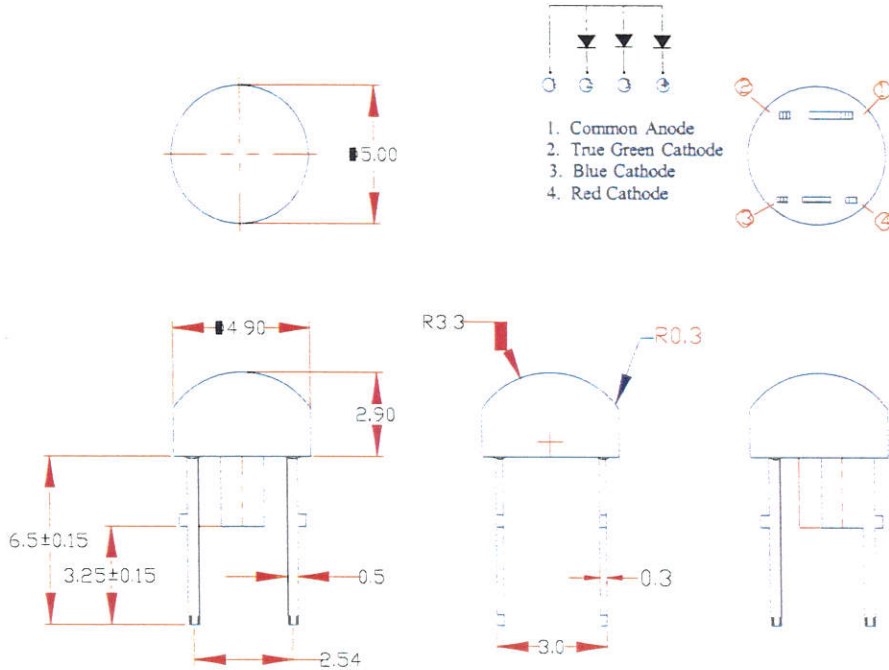

Part NO.	Chip Material			Lens Color	Emission Color
	Red	True Green	Blue		
LL-U42RGBC 2B-042	AlGaInP	InGaN	InGaN	Water Clear	Red & True Green & Blue

Notes:

1. All dimensions are in millimeters (inches).
2. Tolerance is $\pm 0.25\text{mm}$ (.010") unless otherwise noted.
3. Protruded resin under flange is 1.0mm (.04") max.
4. Lead spacing is measured where the leads emerge from the package.
5. Specifications are subject to change without notice.
6. Precautions for ESD:
Static electricity and surge can damages the LED. It is recommended to use a wrist band or anti-electrostatic glove when handling the LED. All devices, equipment and machinery must be properly grounded.
7. This data-sheet only valid for six months.

Absolute Maximum Ratings at Ta=25°C

Parameter	Emitting Color	MAX.	Unit
Power Dissipation	Red	84	mW
	True Green	80	
	Blue	80	
Peak Forward Current (1/10 Duty Cycle, 0.1ms Pulse Width)		100	mA
Continuous Forward Current	Red	35	mA
	True Green	20	
	Blue	20	
Derating Linear From 50°C	0.4		mA/°C
Reverse Voltage	5		V
Electrostatic Discharge (ESD)	Red	1500	V
	True Green	1000	
	Blue		
Operating Temperature Range	-30°C to +80°C		
Storage Temperature Range	-40°C to +100°C		
Lead Soldering Temperature [4mm(.157") From Body]	255±5°C for 5 Seconds		
Wave Soldering Temperature	Peak Temperature 245°C~260°C for 10 Seconds		

Electrical Optical Characteristics at Ta=25°C

Parameter	Symbol	Emitting Color	Min.	Typ.	Max.	Unit	Test Condition
Luminous Intensity	I _v	Red	210	400		mcd	I _F =20mA Note 1
		True Green	460	850			
		Blue	94	210			
Viewing Angle	20 _{1/2}	Red	135	145	155	Deg	Note 2
		True Green	140	150	160		
		Blue	145	155	165		
Peak Emission Wavelength	λ _p	Red	625	630	635	nm	Measurement @Peak
		True Green	515	520	525		
		Blue	460	465	470		
Dominant Wavelength	λ _d	Red	617	622	627	nm	Note 3
		True Green	520	525	530		
		Blue	465	470	475		
Spectral Line Half-Width	Δλ	Red	18	23	28	nm	I _F =20mA
		True Green	30	35	40		
		Blue	30	35	40		
Forward Voltage	V _F	Red	1.8	2.0	2.4	V	I _F =20mA
		True Green	2.8	3.2	3.8		
		Blue	2.8	3.3	3.8		
Reverse Current	I _R	Red			10	μA	V _R =5V
		True Green					
		Blue					

Notes:

1. Luminous intensity is measured with a light sensor and filter combination that approximates the CIE eye-response curve.
2. θ_{1/2} is the off-axis angle at which the luminous intensity is half the axial luminous intensity.
3. The dominant wavelength (λ_d) is derived from the CIE chromaticity diagram and represents the single wavelength which defines the color of the device.
4. Forward voltage measurement allowance is ±0.1V
5. Luminous Intensity Measurement Allowance is ± 10%

Typical Electrical / Optical Characteristics Curves
(25°C Ambient Temperature unless Otherwise Noted)

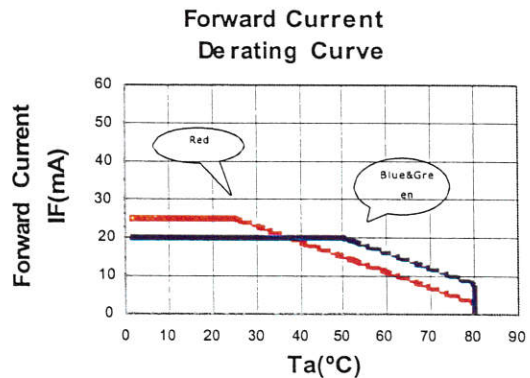
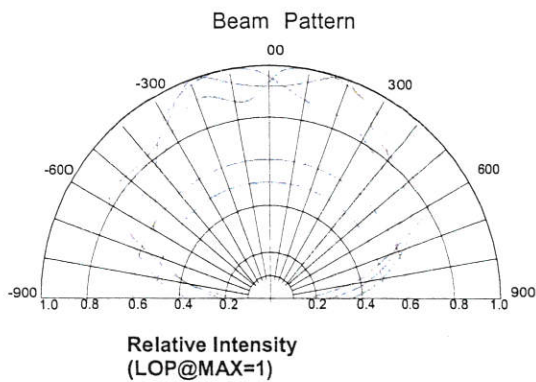
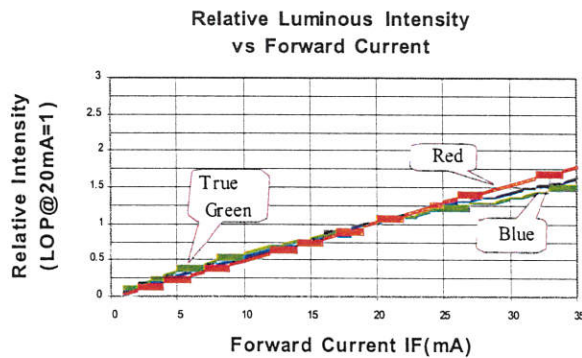
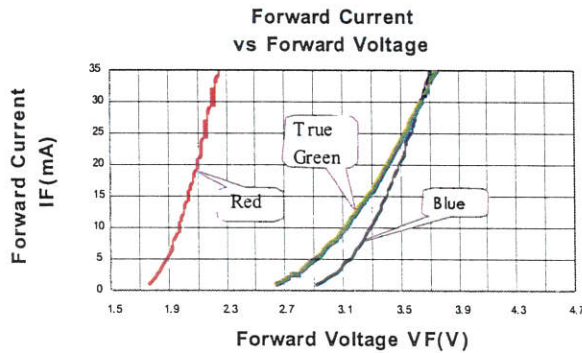
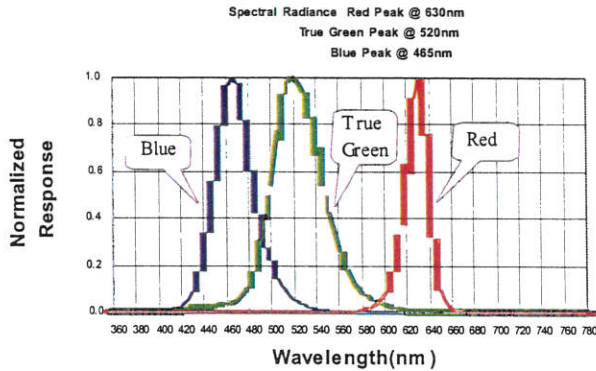

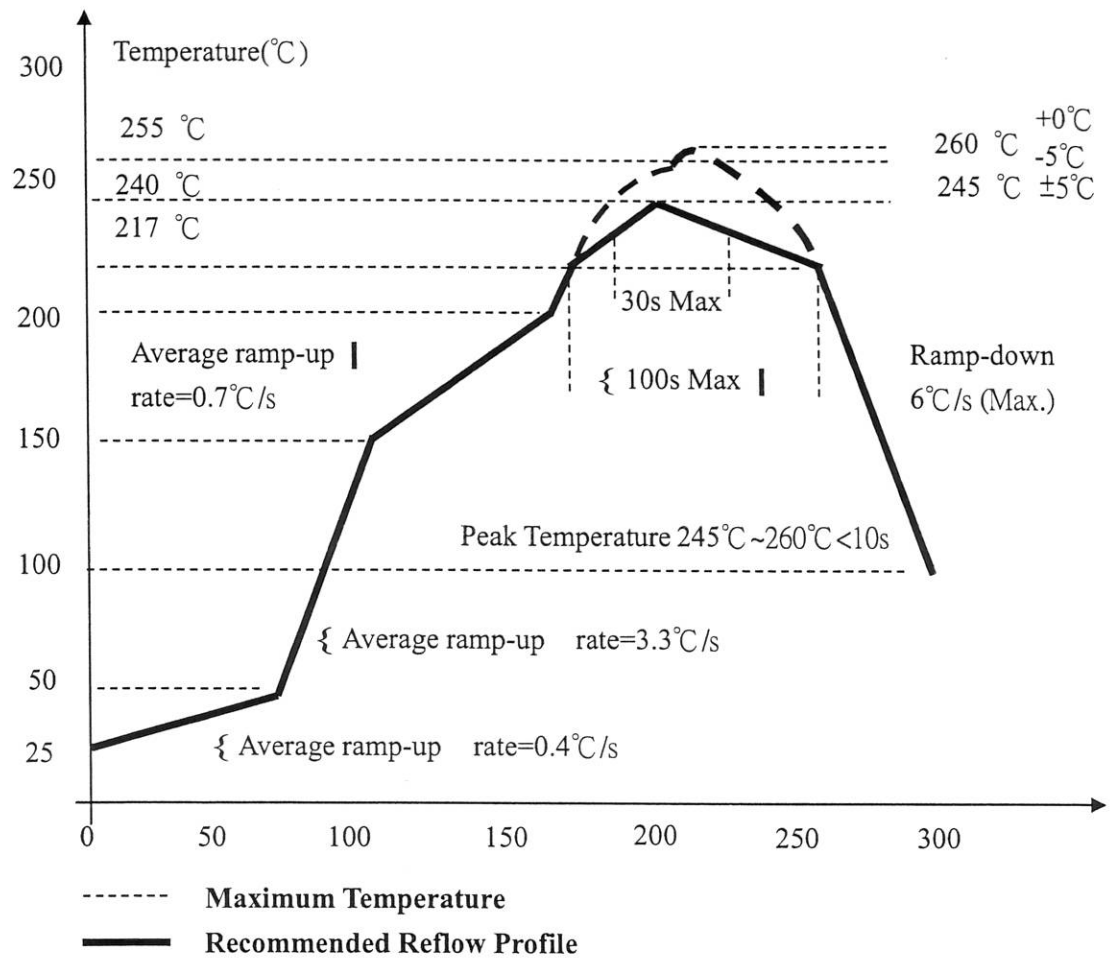

THIS PAGE LEFT BLANK INTENTIONALLY

SUGGESTED ADA GUIDELINES FOR
FRONT, REAR AND CURBSIDE
DOT MATRIX SIGNS

(THIS GUIDELINE SUPPOSES THAT THE FRONT SIGN IS MOUNTED AS FAR FORWARD IN THE CAVITY AS POSSIBLE)

All of the surface (Top row to Bottom row) of the dot matrix signs shall be visible to a person who is 5' 3" (160cm) tall as described below:

Front and Rear Signs:

The 5'3" person should be able to view the entire surface of the sign from 3 feet (914mm) from the front (or rear) of the bus and 1 foot (305mm) from either side of the front (or rear) sign.

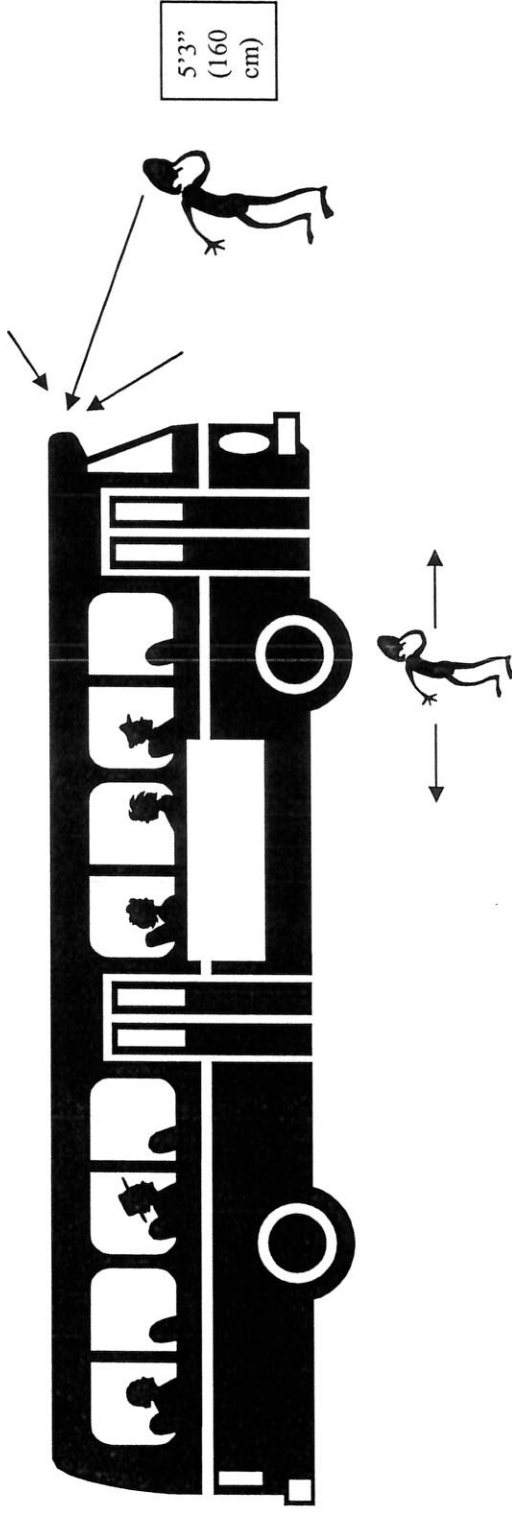

Curbside Sign:

The 5'3" person should be able to view the entire surface of the sign from directly in front of the sign and 1 foot (305mm) away from the side of the bus.

THE INFORMATION CONTAINED HEREIN IS PROPRIETARY TO NEW FLYER INDUSTRIES, L.P. IT IS NOT TO BE REPRODUCED OR TRANSMITTED IN ANY FORM OR BY ANY MEANS, ELECTRONIC OR MECHANICAL, INCLUDING PHOTOCOPYING, RECORDING, OR BY ANY INFORMATION STORAGE AND RETRIEVAL SYSTEM, WITHOUT THE WRITTEN PERMISSION OF NEW FLYER INDUSTRIES, L.P. THIS DOCUMENT IS UNCLASSIFIED AND ALL RIGHTS ARE RESERVED.

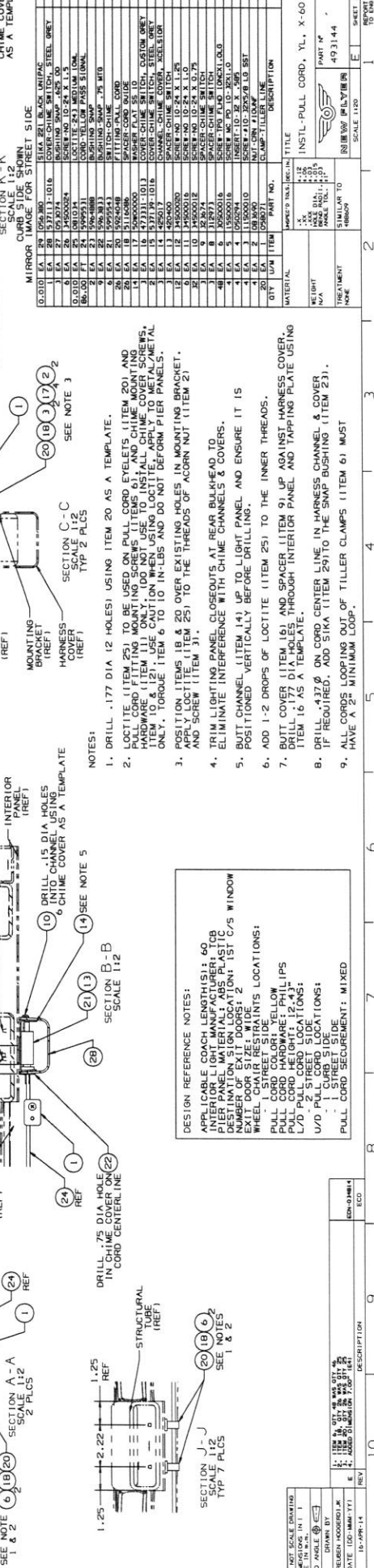
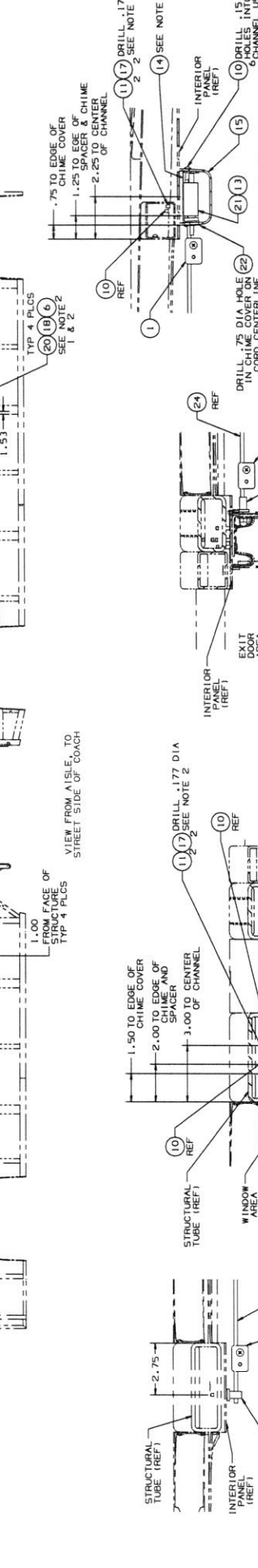
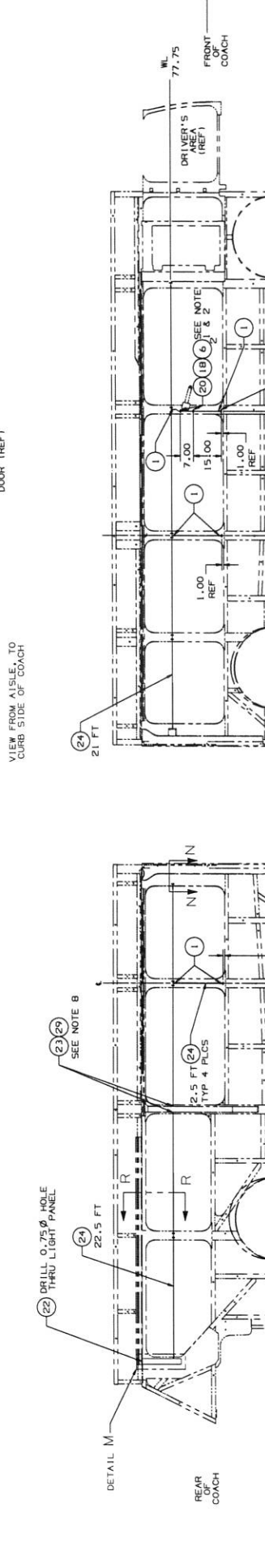
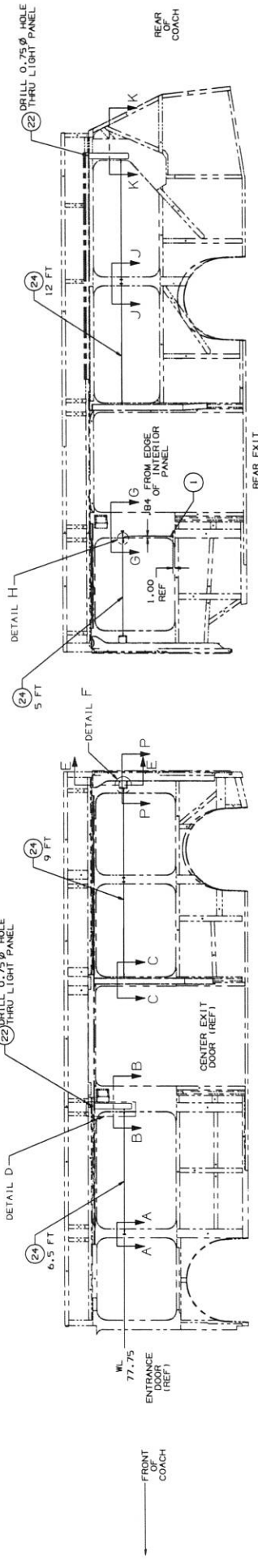

QTY	UOM	ITEM	DESCRIPTION	WEIGHT
1	EA	1	12 INCH DIAMETER CHAIR RESTRAINTS	0.20
1	EA	2	12 INCH DIAMETER CHAIR RESTRAINTS	0.20
1	EA	3	12 INCH DIAMETER CHAIR RESTRAINTS	0.20
1	EA	4	12 INCH DIAMETER CHAIR RESTRAINTS	0.20
1	EA	5	12 INCH DIAMETER CHAIR RESTRAINTS	0.20
1	EA	6	12 INCH DIAMETER CHAIR RESTRAINTS	0.20
1	EA	7	12 INCH DIAMETER CHAIR RESTRAINTS	0.20
1	EA	8	12 INCH DIAMETER CHAIR RESTRAINTS	0.20
1	EA	9	12 INCH DIAMETER CHAIR RESTRAINTS	0.20
1	EA	10	12 INCH DIAMETER CHAIR RESTRAINTS	0.20
1	EA	11	12 INCH DIAMETER CHAIR RESTRAINTS	0.20
1	EA	12	12 INCH DIAMETER CHAIR RESTRAINTS	0.20
1	EA	13	12 INCH DIAMETER CHAIR RESTRAINTS	0.20
1	EA	14	12 INCH DIAMETER CHAIR RESTRAINTS	0.20
1	EA	15	12 INCH DIAMETER CHAIR RESTRAINTS	0.20
1	EA	16	12 INCH DIAMETER CHAIR RESTRAINTS	0.20
1	EA	17	12 INCH DIAMETER CHAIR RESTRAINTS	0.20
1	EA	18	12 INCH DIAMETER CHAIR RESTRAINTS	0.20
1	EA	19	12 INCH DIAMETER CHAIR RESTRAINTS	0.20
1	EA	20	12 INCH DIAMETER CHAIR RESTRAINTS	0.20
1	EA	21	12 INCH DIAMETER CHAIR RESTRAINTS	0.20
1	EA	22	12 INCH DIAMETER CHAIR RESTRAINTS	0.20

- DESIGN REFERENCE NOTES:**
- APPLICABLE COACH LENGTH(S): 60
 - PIER PANEL MATERIAL: ABS/PLASTIC
 - DESTINATION SIGN LOCATION: 1ST C/S WINDOW
 - EXIT DOOR SIZE: WIDE
 - WHEEL CHAIR RESTRAINTS LOCATIONS:
PULL CORD COLOR: YELLOW
 - PULL CORD HARDWARE: PHILLIPS
 - C/V/D PULL CORD LOCATIONS:
- 2 - STREET SIDE
U/D PULL CORD LOCATIONS:
- 1 - STREET SIDE
 - PULL CORD SECUREMENT: MIXED
- NOTES:**
- DRILL .177 DIA. 12 HOLES USING ITEM 20 AS A TEMPLATE.
 - LOCTITE (ITEM 25) TO BE USED ON ALL CORD EYELETS (ITEM 20) AND HARDWARE (ITEM 11) ONLY. DO NOT USE TO INSTALL CHIME COVER SCREWS. ITEM 10 & 12. USE CAUTION WHEN USING LOCTITE. APPLY TO ALUMINUM ONLY. TORQUE ITEM 6 TO 10 IN LBS AND DO NOT DEFORM PIER PANELS.
 - POSITION ITEMS 18 & 20 OVER EXISTING HOLES IN MOUNTING BRACKET.
 - TRIM LIGHTING PANEL CLOSEOUTS AT REAR BULKHEAD TO ELIMINATE INTERFERENCE WITH CHIME CHANNELS & COVERS.
 - BUILT CHANNEL (ITEM 14) UP TO LIGHT PANEL AND ENSURE IT IS POSITIONED VERTICALLY BEFORE DRILLING.
 - ADD 1-2 DROPS OF LOCTITE (ITEM 25) TO THE INNER THREADS.
 - BUTT COVER (ITEM 16) AND SPACER (ITEM 9) UP AGAINST HARNES COVER. ITEM 16 AS A TEMPLATE.
 - IF REQUIRED, ADD STIK (ITEM 29) TO THE SWAP BUSHING (ITEM 23).
 - ALL CORDS COILING OFF OF TILLER CLAMPS (ITEM 6) MUST HAVE A MINIMUM LOOP.

MATERIAL	QTY	UOM	ITEM	DESCRIPTION	WEIGHT
1/2" DIA. BLACK UNIFAC	1	EA	23	1/2" DIA. BLACK UNIFAC	0.25
COVER CHIME SWITCH, STEEL GREY	1	EA	20	COVER CHIME SWITCH, STEEL GREY	0.52
SCREWS 10-24 X 1.5	6	EA	20	SCREWS 10-24 X 1.5	0.01
1/2" DIA. BLACK UNIFAC	1	EA	23	1/2" DIA. BLACK UNIFAC	0.25
COVER CHIME SWITCH, STEEL GREY	1	EA	20	COVER CHIME SWITCH, STEEL GREY	0.52
SCREWS 10-24 X 1.5	6	EA	20	SCREWS 10-24 X 1.5	0.01
1/2" DIA. BLACK UNIFAC	1	EA	23	1/2" DIA. BLACK UNIFAC	0.25
COVER CHIME SWITCH, STEEL GREY	1	EA	20	COVER CHIME SWITCH, STEEL GREY	0.52
SCREWS 10-24 X 1.5	6	EA	20	SCREWS 10-24 X 1.5	0.01
1/2" DIA. BLACK UNIFAC	1	EA	23	1/2" DIA. BLACK UNIFAC	0.25
COVER CHIME SWITCH, STEEL GREY	1	EA	20	COVER CHIME SWITCH, STEEL GREY	0.52
SCREWS 10-24 X 1.5	6	EA	20	SCREWS 10-24 X 1.5	0.01
1/2" DIA. BLACK UNIFAC	1	EA	23	1/2" DIA. BLACK UNIFAC	0.25
COVER CHIME SWITCH, STEEL GREY	1	EA	20	COVER CHIME SWITCH, STEEL GREY	0.52
SCREWS 10-24 X 1.5	6	EA	20	SCREWS 10-24 X 1.5	0.01
1/2" DIA. BLACK UNIFAC	1	EA	23	1/2" DIA. BLACK UNIFAC	0.25
COVER CHIME SWITCH, STEEL GREY	1	EA	20	COVER CHIME SWITCH, STEEL GREY	0.52
SCREWS 10-24 X 1.5	6	EA	20	SCREWS 10-24 X 1.5	0.01
1/2" DIA. BLACK UNIFAC	1	EA	23	1/2" DIA. BLACK UNIFAC	0.25
COVER CHIME SWITCH, STEEL GREY	1	EA	20	COVER CHIME SWITCH, STEEL GREY	0.52
SCREWS 10-24 X 1.5	6	EA	20	SCREWS 10-24 X 1.5	0.01
1/2" DIA. BLACK UNIFAC	1	EA	23	1/2" DIA. BLACK UNIFAC	0.25
COVER CHIME SWITCH, STEEL GREY	1	EA	20	COVER CHIME SWITCH, STEEL GREY	0.52
SCREWS 10-24 X 1.5	6	EA	20	SCREWS 10-24 X 1.5	0.01
1/2" DIA. BLACK UNIFAC	1	EA	23	1/2" DIA. BLACK UNIFAC	0.25
COVER CHIME SWITCH, STEEL GREY	1	EA	20	COVER CHIME SWITCH, STEEL GREY	0.52
SCREWS 10-24 X 1.5	6	EA	20	SCREWS 10-24 X 1.5	0.01
1/2" DIA. BLACK UNIFAC	1	EA	23	1/2" DIA. BLACK UNIFAC	0.25
COVER CHIME SWITCH, STEEL GREY	1	EA	20	COVER CHIME SWITCH, STEEL GREY	0.52
SCREWS 10-24 X 1.5	6	EA	20	SCREWS 10-24 X 1.5	0.01
1/2" DIA. BLACK UNIFAC	1	EA	23	1/2" DIA. BLACK UNIFAC	0.25
COVER CHIME SWITCH, STEEL GREY	1	EA	20	COVER CHIME SWITCH, STEEL GREY	0.52
SCREWS 10-24 X 1.5	6	EA	20	SCREWS 10-24 X 1.5	0.01
1/2" DIA. BLACK UNIFAC	1	EA	23	1/2" DIA. BLACK UNIFAC	0.25
COVER CHIME SWITCH, STEEL GREY	1	EA	20	COVER CHIME SWITCH, STEEL GREY	0.52
SCREWS 10-24 X 1.5	6	EA	20	SCREWS 10-24 X 1.5	0.01
1/2" DIA. BLACK UNIFAC	1	EA	23	1/2" DIA. BLACK UNIFAC	0.25
COVER CHIME SWITCH, STEEL GREY	1	EA	20	COVER CHIME SWITCH, STEEL GREY	0.52
SCREWS 10-24 X 1.5	6	EA	20	SCREWS 10-24 X 1.5	0.01

NOTES FOR INSTALLATION DRAWINGS PLEASE REFER TO ATTACHED IMP DRAW SHEET FOR PARTS LISTING

THIS INFORMATION CONTAINS PROPRIETARY TO THE COMPANY AND ALL RIGHTS ARE RESERVED. NO PART OF THIS DOCUMENT IS TO BE REPRODUCED OR TRANSMITTED IN ANY FORM OR BY ANY MEANS, ELECTRONIC OR MECHANICAL, INCLUDING PHOTOCOPYING, RECORDING, OR BY ANY INFORMATION STORAGE AND RETRIEVAL SYSTEM, WITHOUT PERMISSION IN WRITING FROM THE COMPANY. ALL RIGHTS ARE RESERVED.

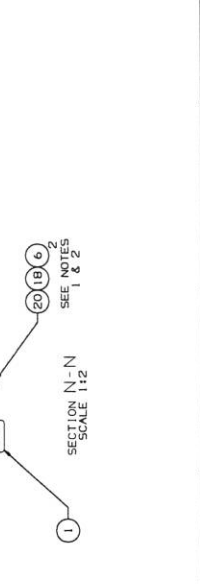
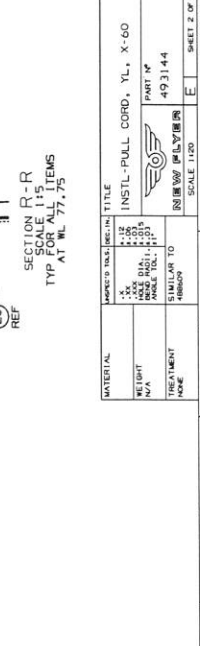
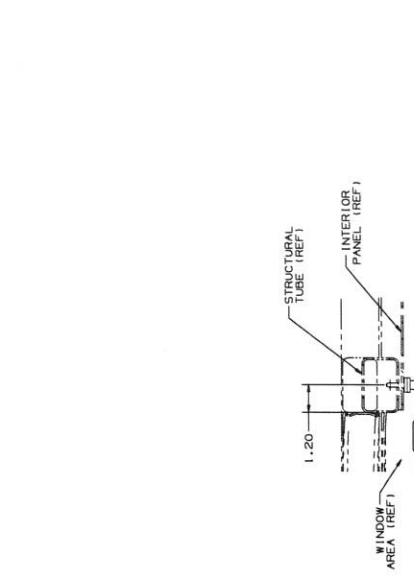
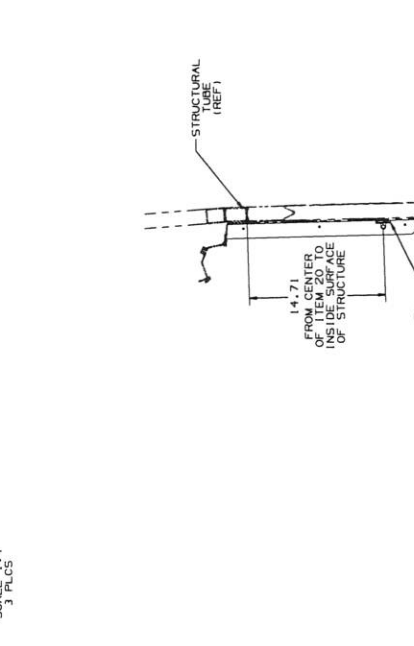
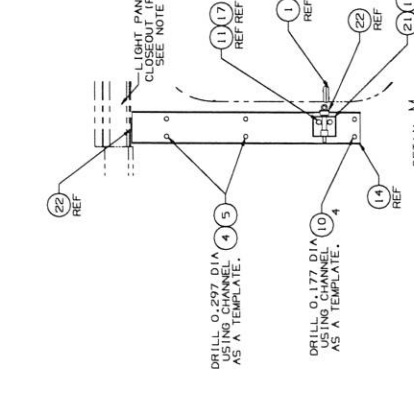
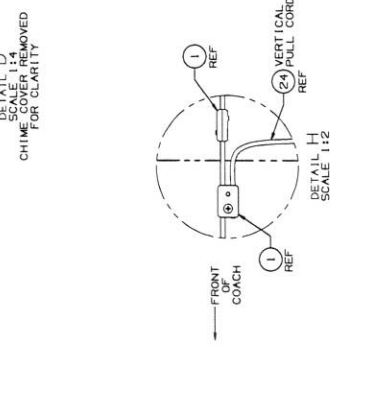
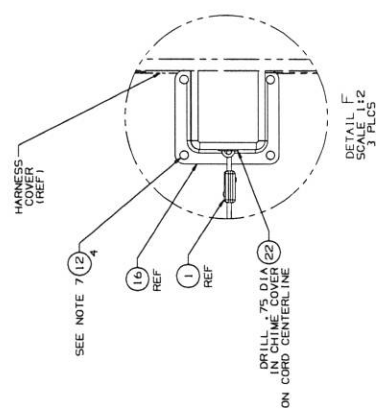
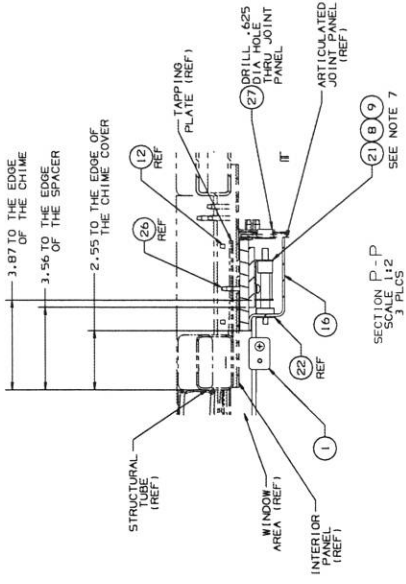
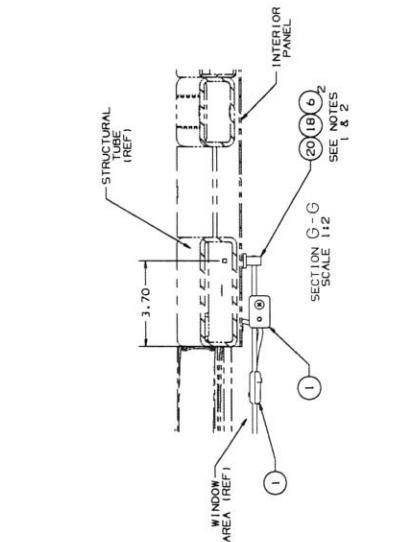

NO	REV	DESCRIPTION	DATE	BY	CHECKED
1	1	ISSUED FOR CONSTRUCTION	15-MAR-14	REUBEN MOORE	REUBEN MOORE
2	1	ISSUED FOR CONSTRUCTION	15-MAR-14	REUBEN MOORE	REUBEN MOORE
3	1	ISSUED FOR CONSTRUCTION	15-MAR-14	REUBEN MOORE	REUBEN MOORE
4	1	ISSUED FOR CONSTRUCTION	15-MAR-14	REUBEN MOORE	REUBEN MOORE
5	1	ISSUED FOR CONSTRUCTION	15-MAR-14	REUBEN MOORE	REUBEN MOORE
6	1	ISSUED FOR CONSTRUCTION	15-MAR-14	REUBEN MOORE	REUBEN MOORE
7	1	ISSUED FOR CONSTRUCTION	15-MAR-14	REUBEN MOORE	REUBEN MOORE
8	1	ISSUED FOR CONSTRUCTION	15-MAR-14	REUBEN MOORE	REUBEN MOORE
9	1	ISSUED FOR CONSTRUCTION	15-MAR-14	REUBEN MOORE	REUBEN MOORE
10	1	ISSUED FOR CONSTRUCTION	15-MAR-14	REUBEN MOORE	REUBEN MOORE

MATERIAL	ALUMINUM
FINISH	ANODIZED
HEIGHT	1.20
WEIGHT	0.10
TREATMENT	N/A
NOTE	SEE NOTE 1

TITLE	INSTL-PULL CORD, YL, X-60
PART NO	49.31.44
SCALE	SCALE 1:2
DATE	15-MAR-14
BY	REUBEN MOORE
CHECKED	REUBEN MOORE
NO	1
REV	1

NO	1
REV	1

THE INFORMATION CONTAINED IN THIS DRAWING IS PROPRIETARY TO NEW FLYER INDUSTRIES CANADA ULC OR ITS AFFILIATES ("NEW FLYER"). THIS DRAWING AND ALL MATERIAL DELIVERED WITH IT MUST BE RETURNED UPON REQUEST AND SHOWN TO THE USER OF THE PRODUCT. NO MORE PATENTS MAY BE PENDING FOR THE PRODUCTS DEPICTED HEREIN. (C) 2013 NEW FLYER INDUSTRIES CANADA ULC. ALL RIGHTS RESERVED.

NOTE: FOR INSTALLATION DRAWINGS PLEASE REFER TO ATTACHED WIP BOM SHEET FOR PARTS LISTING

DRAWING N°
536399

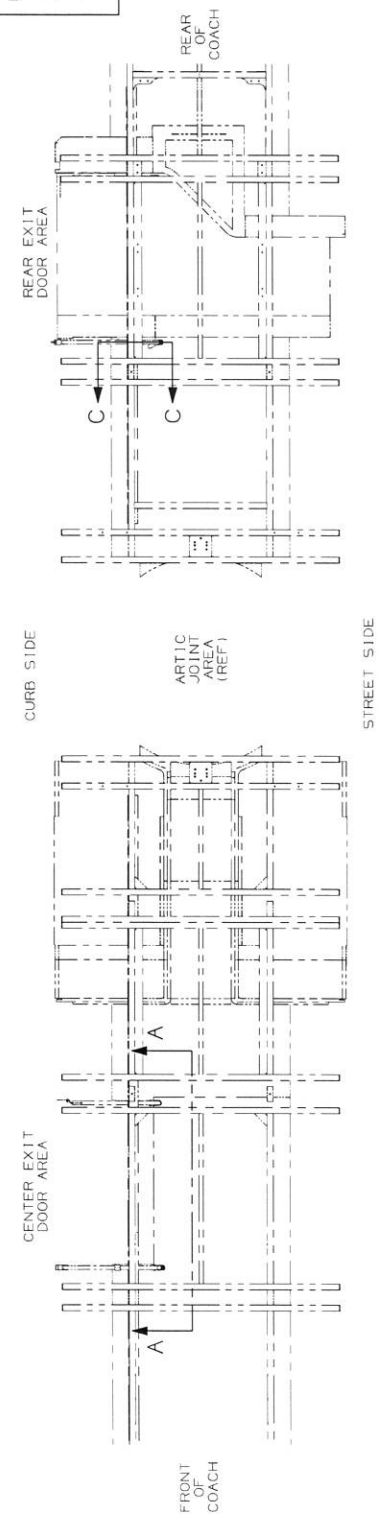

DESIGN REFERENCE NOTES:

- VALID FOR 60" XGELSTOR COACH
- SINGLE LOW PROFILE PUSH BUTTON MOUNTED FORWARD OF CURBSIDE EXIT DOORS
- PUSH BUTTON HEIGHT OF 44.00" FROM FLOOR TO BOTTOM OF SWITCH

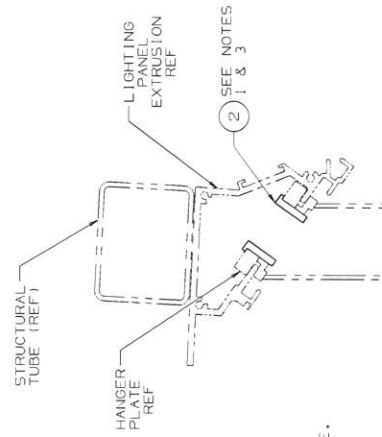

SECTION C-C
SCALE 1:1
TYP 2 PLCS
VIEW ROTATED 90° CW

DRILL .150 Ø 2 HOLES THRU STANCHION MOUNTING SURFACE ONLY. USING SPACER, ITEM 4 AS A TEMPLATE. SEE NOTE 2 TYP 2 PLCS

DRILL .625 Ø HOLE THRU STANCHION MOUNTING SURFACE ONLY. SEE NOTE 1

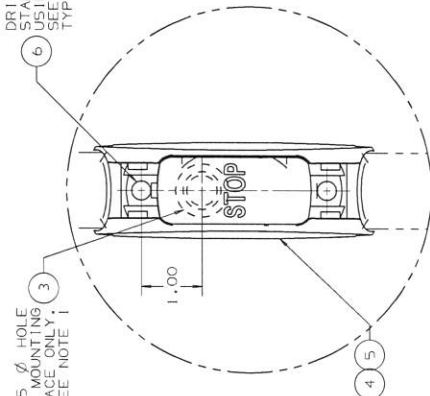

SEE NOTES 1 & 4

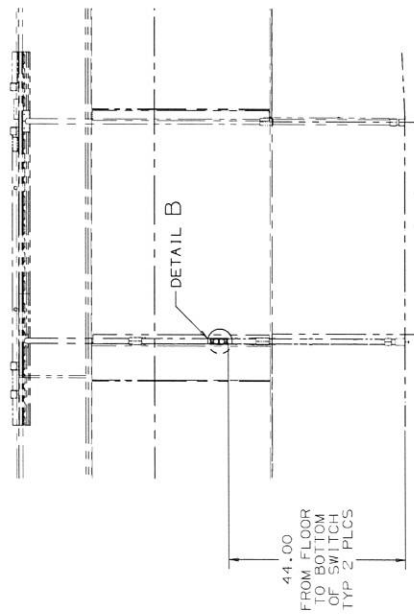

NOTES:

1. APPLY SEALER, ITEM 1 TO CONTACT SURFACES WHEN INSTALLING SNAP BUSHINGS AND SPACER, ITEMS 2, 3, & 4. CLEAN OFF ANY EXCESS SEALER AND ALLOW SUFFICIENT TIME FOR SNAP BUSHINGS BEFORE ROUTING HARNESS THROUGH HOLES
2. REMOVE SCREW COVERS FROM SWITCH, ITEM 5 BEFORE INSTALLATION ON THE COACH. REPLACE SCREW COVERS AFTER SWITCH INSTALLATION.
3. INSTALL BUSHING ITEM 2 IN HANGER PLATE.
4. PUSH BUTTON TO BE FACING CENTER AISLE.
5. ENSURE ALL DRILLED HOLES AND ROUGH EDGES ARE DEBURRED AS PER NFIL SPEC 412828.

DETAIL B
SCALE 1:1
2 PLCS
SCREW COVERS REMOVED FOR CLARITY

QTY	U/M	ITEM	PART NO.	DESCRIPTION	WEIGHT
4	EA	6	38596012	SCREW TDS .625 X 3/4	
2	EA	2	314450	SPACER-STOP RED'D SWITCH	
2	EA	3	053074	BUSHING SNAP .625 OD	
2	EA	2	418175	BUSHING-SNAP 3/4 ID THK	
0.010	EA	1	002459	LOCUTITE .004" GLUE	

MATERIAL	WEIGHT TBS	SEC. IN	TITLE
N/A			INSTL - PUSH BTN, EXIT AREA X-60
			PART N°
			536399
			SCALE 1:120
			SHEET 1 OF 1
			REPORT ALL ERRORS TO ENG. DEPT.

REV	DESCRIPTION	ECO
A	RELEASE TO PRODUCTION	ECO-026221

DO NOT SCALE DRAWING
IN 1:1
ARE IN N.P.
THD ANGLE
DRAWN BY
REUBEN HOOPER/LK
DATE 100-1000-111
24-SEP-13

THE INFORMATION CONTAINED IN THIS DRAWING IS PROPRIETARY TO THE COMPANY AND IS TO BE KEPT CONFIDENTIAL. NO PARTS OR MATERIALS SHALL BE REPRODUCED, COPIED, OR TRANSMITTED IN ANY FORM OR BY ANY MEANS, WITHOUT THE WRITTEN PERMISSION OF THE COMPANY. ALL RIGHTS RESERVED.

NOTE FOR INSTALLATION DRAWINGS PLEASE REFER TO ATTACHED MPD 80M SHEET FOR PARTS LISTING

DRAWING NO
440330

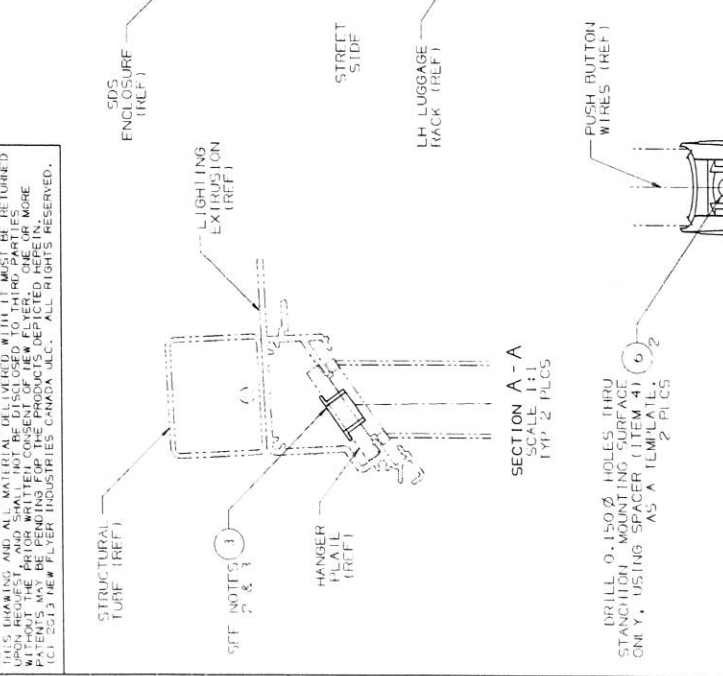
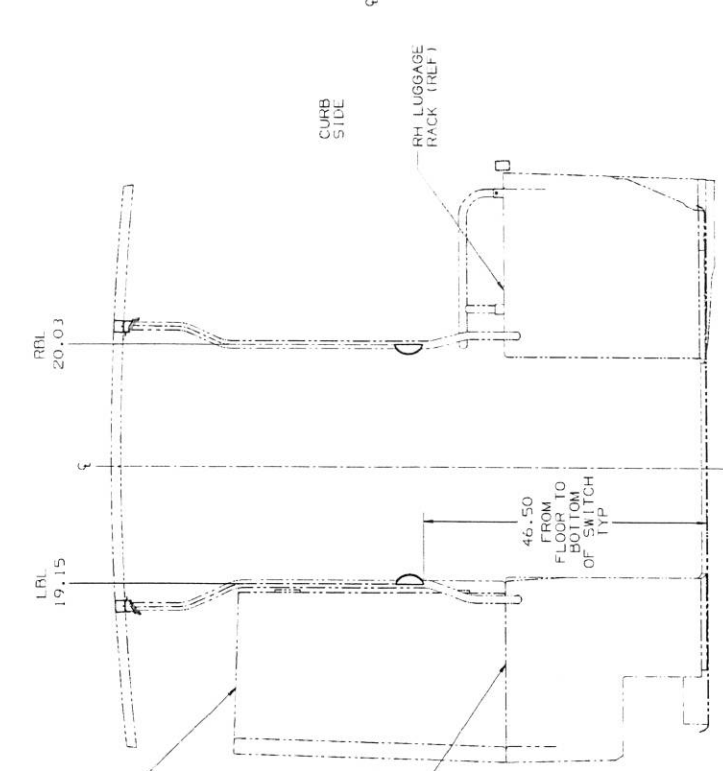
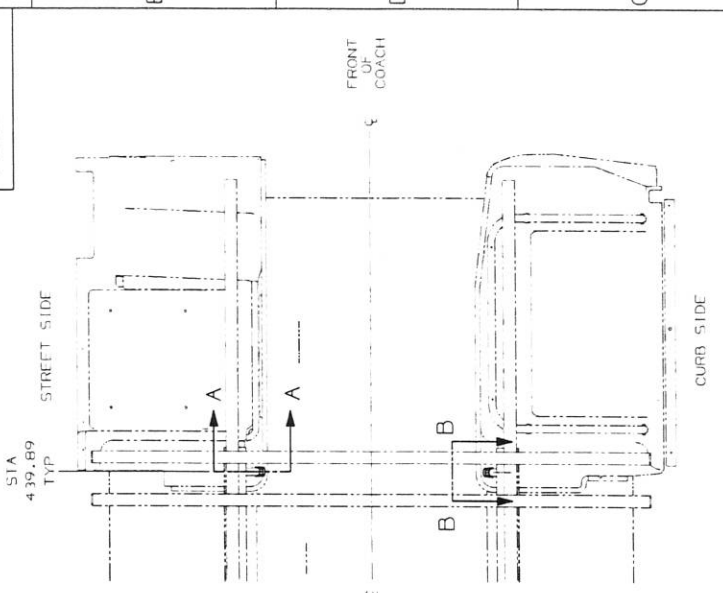

- NOTES:
1. REMOVE SCREW COVERS FROM SWITCH (ITEM 5), BEFORE INSTALLING ON COACH. REPLACE SCREW COVERS AFTER SWITCH INSTALLATION.
 2. INSTALL BUSHING (ITEM 3) IN HANGER PLATE.
 3. APPLY ITEM 1 TO CONTACT SURFACES WHEN INSTALLING SHAP BUSHINGS (ITEM 1), AND SPACER (ITEM 4). ALLOW SUFFICIENT DRILLING TIME FOR SHAP BUSHINGS BEFORE ROUTING HARNESS THROUGH HOLES.
 4. PUSH BUTTONS TO BE FACING CENTER AISLE.
 5. REMOVE ALL SHARP EDGES AND BURRS FROM DRILLING AS PER NF IL SPEC 412828.

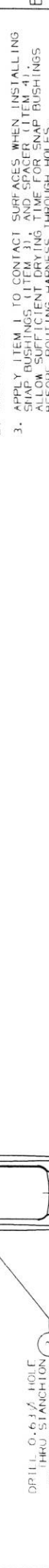

QTY	U/M	ITEM	PART NO.	DESCRIPTION	WEIGHT
4	EA	6	35526012	SCREW TRS 1/8" X 3/4"	
2	EA	5	314450	SWITCH-STOP RED 'D	
2	EA	3	314450	SPACER-STOP RED 'D SWITCH	
4	EA	1	0053074	BUSHING SHAP .625 OD	
0.010	EA	1	002459	LOCUTITE -104-GLUE	

MATERIAL: N/A
WEIGHT: N/A
TREATMENT: SEE NOTES

SCALE 1:1
TITLE: INSTL - PUSH BTN, WHLHS XCELSIOR

PART NO: 440330

SCALE 1:1
SHEET 1 OF 1

REPORT ALL ERRORS TO ENR. DEPT.

DO NOT SCALE DRAWING DIMENSIONS IN 1 ARE IN M.M.

THD ANGLE

DRAWN BY: MADINA RAMIREZ

DATE: 100-MMM-YY

01-SEP-13

REV: 1

DESCRIPTION: ECO

ECN: 025296

THIS INFORMATION CONTAINS PROPRIETARY AND CONFIDENTIAL INFORMATION OF NEW FLYER INDUSTRIES CANADA. IT IS APPLICABLE TO THE ALTERNATE PARTS LISTED HEREIN AND IS NOT TO BE REPRODUCED OR TRANSMITTED IN ANY FORM OR BY ANY MEANS, ELECTRONIC OR MECHANICAL, INCLUDING PHOTOCOPYING, RECORDING, OR BY ANY INFORMATION STORAGE AND RETRIEVAL SYSTEM. WITHOUT THE WRITTEN PERMISSION OF NEW FLYER INDUSTRIES CANADA U.S.A. ALL RIGHTS RESERVED. (C) 2013 NEW FLYER INDUSTRIES CANADA U.S.A.

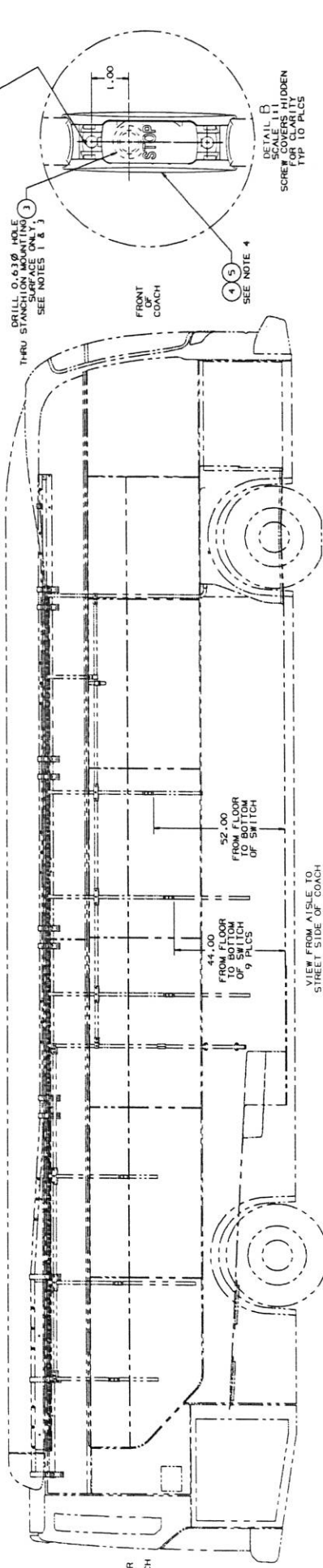
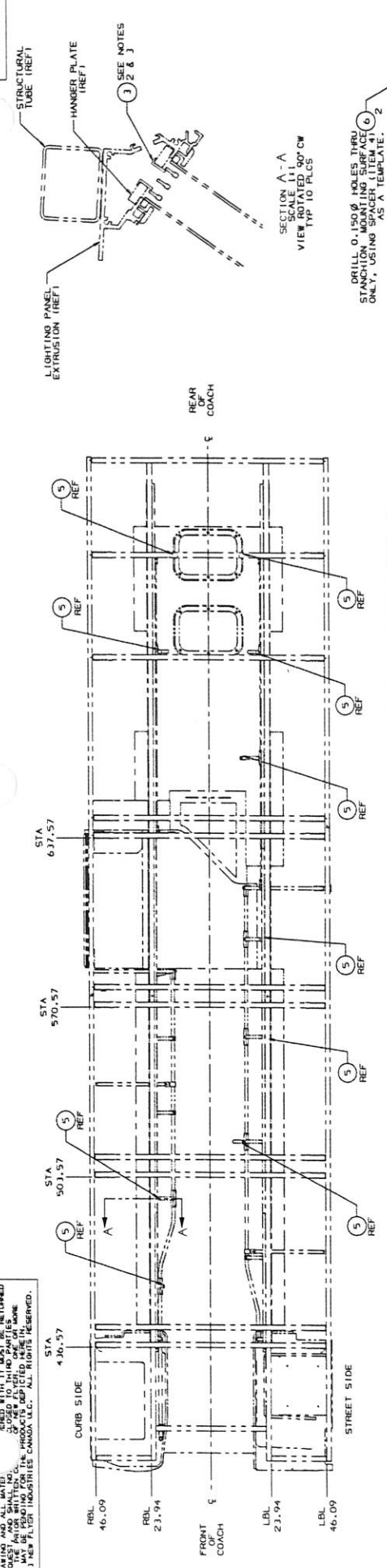

DESIGN REFERENCE NOTES:

- XCELLS FOR COACH CONFIG
- VALID FOR 40' COACH
- WIDE EXIT LOCATIONS
- VALID FOR PRETORIA OR TCB LIGHTING
- NO SEATING STANCHION PUSH BUTTONS
- PUSH BUTTON HEIGHTS OF 44" & 52"

- NOTES:**
1. REMOVE SCREW COVERS FROM SWITCH (ITEM 5) BEFORE INSTALLING ON COACH. REPLACE SCREW COVERS AFTER SWITCH INSTALLATION.
 2. INSTALL BUSHING (ITEM 3) IN HANGER PLATE.
 3. APPLY ITEM 1 TO CONTACT SURFACES WHEN INSTALLING SNAP BUSHINGS (ITEMS 3), AND SPACER (ITEM 4). ALLOW SUFFICIENT ROUTING HARNES THROUGH HOLES.
 4. PUSH BUTTONS TO BE FACING CENTER AISLE.
 5. REMOVE ALL SHARP EDGES AND BURRS FROM DRILLING AS PER NFIL SPEC 412628.

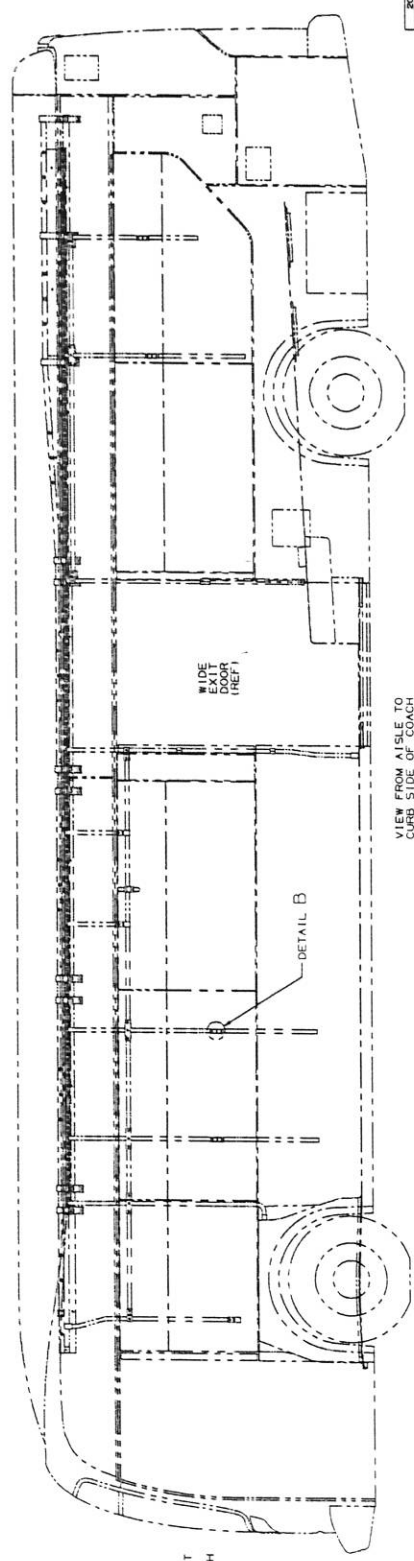
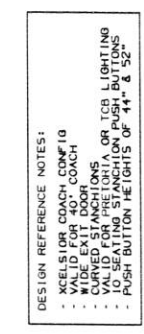

QTY	UOM	ITEM	PART NO.	DESCRIPTION	WEIGHT
20	EA	6	8992012	SCREW TYP 10 PLS	
10	EA	5	34451	SCREW STOP REF 10	
20	EA	3	073274	BUSHING SNAP 45X 00	
10	EA	1	002259	BLK LOCITIE 40T	

MATERIAL		MATERIAL		MATERIAL		MATERIAL	
NAME	SCALE	NAME	SCALE	NAME	SCALE	NAME	SCALE
1.15	1:11	1.15	1:11	1.15	1:11	1.15	1:11
4.0	1:11	4.0	1:11	4.0	1:11	4.0	1:11
4.0	1:11	4.0	1:11	4.0	1:11	4.0	1:11
4.0	1:11	4.0	1:11	4.0	1:11	4.0	1:11

TITLE		SCALE		SHEET		PART	
TITLE-PUSH BUTTON, SEAT X-40		SCALE 1:11		SHEET 1 OF 1		PART #	
DRAWN BY		SCALE 1:11		SHEET 1 OF 1		PART #	
CHECKED BY		SCALE 1:11		SHEET 1 OF 1		PART #	
DATE (DD-MM-YY)		SCALE 1:11		SHEET 1 OF 1		PART #	
RELEASE TO PRODUCTION		SCALE 1:11		SHEET 1 OF 1		PART #	



8725

BIODIESEL

www.sfmta.com

NEW FLYER



السنة

السنة

8725



OHSAS 18001





8725

القطر



aperturas

"WARNING"
YOUR PICTURE AND VOICE
MAY BE RECORDED ON THIS VEHICLE

