

OWNER'S & BENEFICIARY'S STATEMENT

WE HEREBY STATE THAT WE ARE THE ONLY OWNERS OF AND HOLDERS OF SECURITY INTEREST IN AND TO THE REAL PROPERTY INCLUDED WITHIN THE SUBDIVISION SHOWN ON THIS MAP, THAT WE ARE THE ONLY PERSONS HAVING RECORD TITLE INTEREST IN THE SUBDIVIDED PROPERTY WHOSE CONSENT IS NECESSARY TO PASS CLEAR TITLE TO THE PROPERTY, AND THAT WE HEREBY CONSENT TO THE PREPARATION AND RECORDATION OF THIS FINAL MAP AS SHOWN WITHIN THE DISTINCTIVE BORDER LINE.

OWNER: 915 NORTH POINT LLC, A DELAWARE LIMITED LIABILITY COMPANY

BY: JS SULLIVAN CAPITAL, LLC, A CALIFORNIA LIMITED LIABILITY COMPANY, ITS SOLE MEMBER

BY: [Signature]
HYUN SEAN PARK SULLIVAN, ITS MANAGING MEMBER

BENEFICIARY: PREFERRED BANK

SIGNED: [Signature]
PRINT NAME: **ALICE HUANG** TITLE: **EVP**

OWNER'S ACKNOWLEDGMENT

A NOTARY PUBLIC OR OTHER OFFICER COMPLETING THIS CERTIFICATE VERIFIES ONLY THE IDENTITY OF THE INDIVIDUAL WHO SIGNED THE DOCUMENT TO WHICH THIS CERTIFICATE IS ATTACHED AND NOT THE TRUTHFULNESS, ACCURACY OR VALIDITY OF THAT DOCUMENT.

STATE OF CALIFORNIA)
COUNTY OF San Francisco)

ON September 18, 2024 BEFORE ME, Nikola Cicin-Sain

A NOTARY PUBLIC, PERSONALLY APPEARED Hyun Sean Park Sullivan

WHO PROVED TO ME ON THE BASIS OF SATISFACTORY EVIDENCE TO BE THE PERSON(S) WHOSE NAME(S) IS/ARE SUBSCRIBED TO THE WITHIN INSTRUMENT AND ACKNOWLEDGED TO ME THAT HE/SHE /THEY EXECUTED THE SAME IN HIS/HER/THEIR AUTHORIZED CAPACITY(IES) AND BY HIS/HER/THEIR SIGNATURE(S) ON THE INSTRUMENT THE PERSON(S), OR THE ENTITY UPON BEHALF OF WHICH THE PERSON(S) ACTED, EXECUTED THE INSTRUMENT. I CERTIFY UNDER PENALTY OF PERJURY UNDER THE LAWS OF THE STATE OF CALIFORNIA THAT THE FOREGOING PARAGRAPH IS TRUE AND CORRECT.

WITNESS MY HAND:

SIGNATURE [Signature]

(NOTE: SEAL OPTIONAL IF THE FOLLOWING INFORMATION IS COMPLETED)

NOTARY PUBLIC, STATE OF CA COMMISSION NO.: 2370126

MY COMMISSION EXPIRES: 12/12/2024

COUNTY OF PRINCIPAL PLACE OF BUSINESS: San Francisco

BENEFICIARY'S ACKNOWLEDGMENT

A NOTARY PUBLIC OR OTHER OFFICER COMPLETING THIS CERTIFICATE VERIFIES ONLY THE IDENTITY OF THE INDIVIDUAL WHO SIGNED THE DOCUMENT TO WHICH THIS CERTIFICATE IS ATTACHED AND NOT THE TRUTHFULNESS, ACCURACY OR VALIDITY OF THAT DOCUMENT.

STATE OF CALIFORNIA)
COUNTY OF San Francisco)

ON September 17 BEFORE ME, Kathryn Lin

A NOTARY PUBLIC, PERSONALLY APPEARED Alice Huang

WHO PROVED TO ME ON THE BASIS OF SATISFACTORY EVIDENCE TO BE THE PERSON(S) WHOSE NAME(S) IS/ARE SUBSCRIBED TO THE WITHIN INSTRUMENT AND ACKNOWLEDGED TO ME THAT HE/SHE /THEY EXECUTED THE SAME IN HIS/HER/THEIR AUTHORIZED CAPACITY(IES) AND BY HIS/HER/THEIR SIGNATURE(S) ON THE INSTRUMENT THE PERSON(S), OR THE ENTITY UPON BEHALF OF WHICH THE PERSON(S) ACTED, EXECUTED THE INSTRUMENT. I CERTIFY UNDER PENALTY OF PERJURY UNDER THE LAWS OF THE STATE OF CALIFORNIA THAT THE FOREGOING PARAGRAPH IS TRUE AND CORRECT.

WITNESS MY HAND AND OFFICIAL SEAL:

SIGNATURE [Signature]

(NOTE: SEAL OPTIONAL IF THE FOLLOWING INFORMATION IS COMPLETED)

NOTARY PUBLIC, STATE OF CA COMMISSION NO.: 2480702

MY COMMISSION EXPIRES: Jan 30, 2028

COUNTY OF PRINCIPAL PLACE OF BUSINESS: San Francisco

SURVEYOR'S STATEMENT

THIS MAP WAS PREPARED BY ME OR UNDER MY DIRECTION AND IS BASED UPON A FIELD SURVEY IN CONFORMANCE WITH THE REQUIREMENTS OF THE SUBDIVISION MAP ACT AND LOCAL ORDINANCE AT THE REQUEST OF 915 NORTH POINT LLC, ON NOV. 1, 2019. I HEREBY STATE THAT ALL THE MONUMENTS ARE OF THE CHARACTER AND OCCUPY THE POSITIONS INDICATED OR THAT THEY WILL BE SET IN THOSE POSITIONS BEFORE DEC. 31, 2024, AND THAT THE MONUMENTS ARE, OR WILL BE, SUFFICIENT TO ENABLE THE SURVEY TO BE RETRACED, AND THAT THIS FINAL MAP SUBSTANTIALLY CONFORMS TO THE CONDITIONALLY APPROVED TENTATIVE MAP.

BY: [Signature]

DANIEL J. WESTOVER, L.S. 7779

DATE: 9/13/24



CITY AND COUNTY SURVEYOR'S STATEMENT

I HEREBY STATE THAT I HAVE EXAMINED THIS MAP; THAT THE SUBDIVISION AS SHOWN IS SUBSTANTIALLY THE SAME AS IT APPEARED ON THE TENTATIVE MAP, AND ANY APPROVED ALTERATION THEREOF; THAT ALL PROVISIONS OF THE CALIFORNIA SUBDIVISION MAP ACT AND ANY LOCAL ORDINANCE APPLICABLE AT THE TIME OF APPROVAL OF THE TENTATIVE MAP, IF ANY, HAVE BEEN COMPLIED WITH; AND THAT I AM SATISFIED THIS MAP IS TECHNICALLY CORRECT.

WILLIAM E. BLACKWELL JR., PLS 8251
ACTING CITY AND COUNTY SURVEYOR
CITY AND COUNTY OF SAN FRANCISCO

BY: [Signature]

DATE: 11/18/24



CLERK'S STATEMENT

I, ANGELA CALVILLO, CLERK OF THE BOARD OF SUPERVISORS OF THE CITY AND COUNTY OF SAN FRANCISCO, STATE OF CALIFORNIA, HEREBY STATE THAT SAID BOARD OF SUPERVISORS BY ITS MOTION NO. _____ ADOPTED _____, 20_____, APPROVED THIS MAP ENTITLED "FINAL MAP 12116".

IN TESTIMONY WHEREOF, I HAVE HEREUNTO SUBSCRIBED MY HAND AND CAUSED THE SEAL OF THE OFFICE TO BE AFFIXED.

BY: _____ DATE: _____
CLERK OF THE BOARD OF SUPERVISORS
CITY AND COUNTY OF SAN FRANCISCO
STATE OF CALIFORNIA

RECORDER'S STATEMENT

FILED THIS _____ DAY OF _____, 20_____,

AT _____ M. IN BOOK _____ OF FINAL MAPS AT _____ PAGES _____, AT THE REQUEST OF WESTOVER SURVEYING, INC.

SIGNED _____
COUNTY RECORDER

TAX STATEMENT

I, ANGELA CALVILLO, CLERK OF THE BOARD OF SUPERVISORS OF THE CITY AND COUNTY OF SAN FRANCISCO, STATE OF CALIFORNIA, DO HEREBY STATE THAT THE SUBDIVIDER HAS FILED A STATEMENT FROM THE TREASURER AND TAX COLLECTOR OF THE CITY AND COUNTY OF SAN FRANCISCO, SHOWING THAT ACCORDING TO THE RECORDS OF HIS OR HER OFFICE THERE ARE NO LIENS AGAINST THIS SUBDIVISION OR ANY PART THEREOF FOR UNPAID STATE, COUNTY, MUNICIPAL OR LOCAL TAXES, OR SPECIAL ASSESSMENTS COLLECTED AS TAXES.

DATED: _____ DAY OF _____, 20_____.

CLERK OF THE BOARD OF SUPERVISORS
CITY AND COUNTY OF SAN FRANCISCO
STATE OF CALIFORNIA

APPROVALS

THIS MAP IS APPROVED THIS 18th DAY OF November, 2024.
BY ORDER NO. 211184

BY: [Signature] DATE: 11/19/24

CARLA SHORT
~~INTERIM~~ DIRECTOR OF PUBLIC WORKS
CITY AND COUNTY OF SAN FRANCISCO
STATE OF CALIFORNIA

APPROVED AS TO FORM

DAVID CHIU, CITY ATTORNEY

DEPUTY CITY ATTORNEY
CITY AND COUNTY OF SAN FRANCISCO

BOARD OF SUPERVISOR'S APPROVAL

ON _____, 20_____, THE BOARD OF SUPERVISOR'S OF THE CITY AND COUNTY OF SAN FRANCISCO, STATE OF CALIFORNIA APPROVED AND PASSED MOTION NO. _____, A COPY OF WHICH IS ON FILE IN THE OFFICE OF THE BOARD OF SUPERVISOR'S IN FILE NO. _____.

FINAL MAP No. 12116

A 35 UNIT RESIDENTIAL CONDOMINIUM PROJECT

BEING A 4-LOT SUBDIVISION OF THAT REAL PROPERTY DESCRIBED IN THAT CERTAIN GRANT DEED RECORDED DECEMBER 17, 2019 IN DOCUMENT NO. 2019-K877891-00, RECORDER'S OFFICE OF THE CITY AND COUNTY OF SAN FRANCISCO.

BEING PART OF WESTERN ADDITION BLOCK NO. 31

CITY AND COUNTY OF SAN FRANCISCO

CALIFORNIA
SEPTEMBER, 2024



336 CLAREMONT BLVD. STE 1
SAN FRANCISCO, CA 94127
(415) 242-5400
www.westoversurveying.com

SHEET 1 OF 3 SHEETS

APN 0453-002

915 NORTH POINT STREET

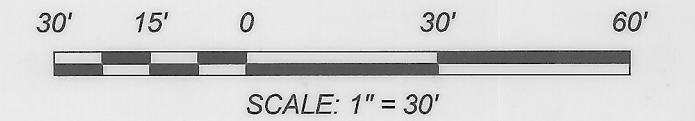

NORTH POINT STREET (68.75' WIDE)

POLK STREET (68.75' WIDE)

LARKIN STREET (68.75' WIDE)

BAY STREET (68.75' WIDE)

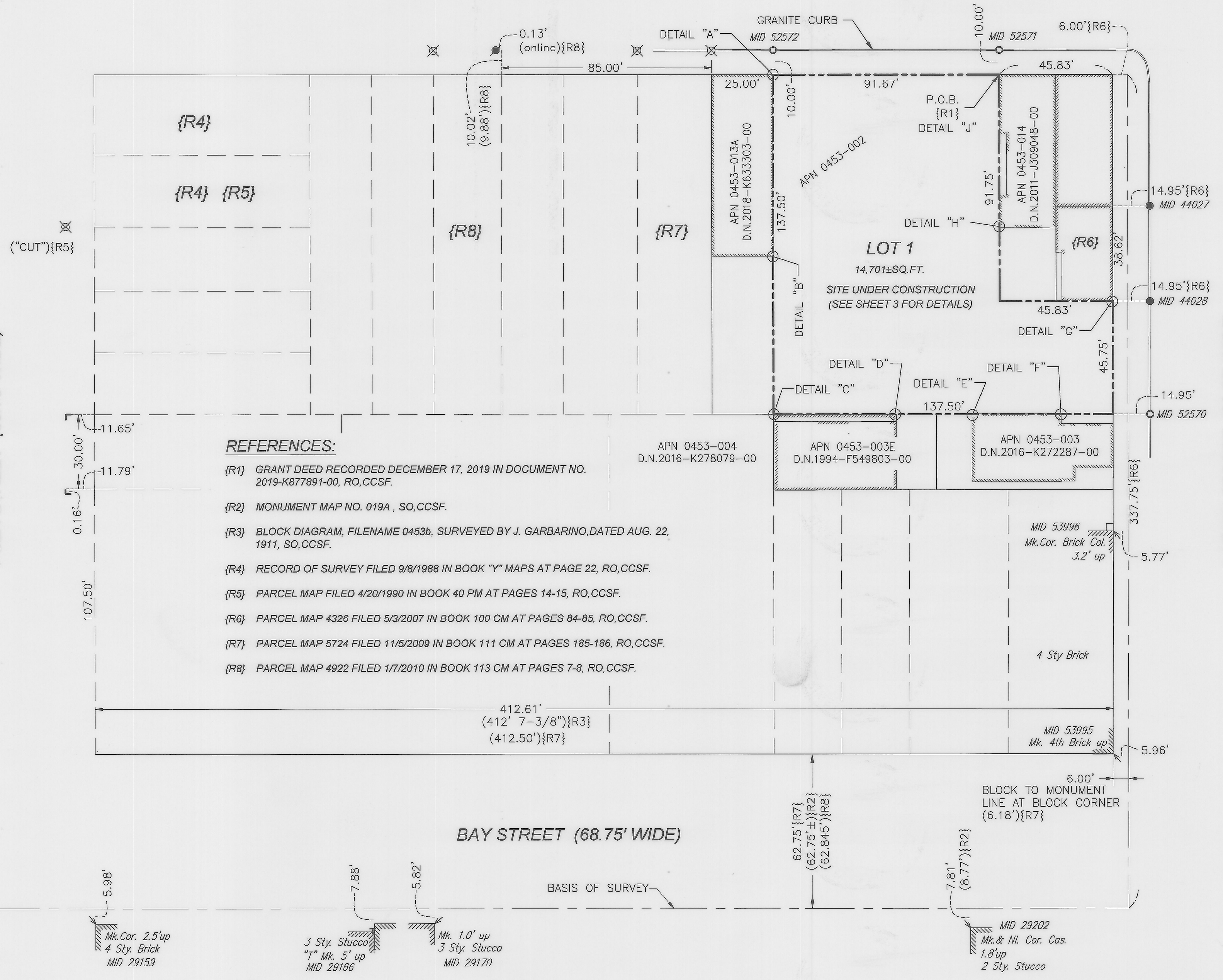

REFERENCES:

- {R1} GRANT DEED RECORDED DECEMBER 17, 2019 IN DOCUMENT NO. 2019-K877891-00, RO,CCSF.
- {R2} MONUMENT MAP NO. 019A, SO,CCSF.
- {R3} BLOCK DIAGRAM, FILENAME 0453b, SURVEYED BY J. GARBARINO, DATED AUG. 22, 1911, SO,CCSF.
- {R4} RECORD OF SURVEY FILED 9/8/1988 IN BOOK "Y" MAPS AT PAGE 22, RO,CCSF.
- {R5} PARCEL MAP FILED 4/20/1990 IN BOOK 40 PM AT PAGES 14-15, RO,CCSF.
- {R6} PARCEL MAP 4326 FILED 5/3/2007 IN BOOK 100 CM AT PAGES 84-85, RO,CCSF.
- {R7} PARCEL MAP 5724 FILED 11/5/2009 IN BOOK 111 CM AT PAGES 185-186, RO,CCSF.
- {R8} PARCEL MAP 4922 FILED 1/7/2010 IN BOOK 113 CM AT PAGES 7-8, RO,CCSF.

LEGEND

- NAIL AND 3/4" DIA. BRASS TAG MARKED "LS 7779" TO BE SET BEFORE 12/31/2024
- FOUND NAIL AND BRASS TAG "LS-6895" PER {R6}
- FOUND NAIL AND BRASS TAG "LS-6975" PER {R8}
- ┌ FOUND "L" CUT IN GRANITE CURB, UNKNOWN ORIGIN
- ⊗ MONUMENT, SFNF (SEARCHED FOR NOT FOUND) PER REFERENCE NUMBER
- PROPERTY LINE
- LOT LINE
- MONUMENT LINE
- REFERENCE LINE ONLY, NOT SURVEYED
- () RECORD MEASUREMENT WHEN DIFFERENT THAN MEASURED ON THIS SURVEY
- {R#} REFERENCE NUMBER
- APN ASSESSOR'S PARCEL NUMBER
- D.N. DOCUMENT NUMBER
- P.O.B. POINT OF BEGINNING
- RO,CCSF RECORDER'S OFFICE, CITY AND COUNTY OF SAN FRANCISCO
- SO,CCSF SURVEYOR'S OFFICE, CITY AND COUNTY OF SAN FRANCISCO
- CM CONDOMINIUM MAP BOOK
- PM PARCEL MAP BOOK
- ▨ BUILDING FOOTPRINT

FINAL MAP No. 12116

A 35 UNIT RESIDENTIAL CONDOMINIUM PROJECT

BEING A SUBDIVISION OF THAT REAL PROPERTY DESCRIBED IN THAT CERTAIN GRANT DEED RECORDED DECEMBER 17, 2019 IN DOCUMENT NO. 2019-K877891-00, RECORDER'S OFFICE OF THE CITY AND COUNTY OF SAN FRANCISCO.

BEING PART OF WESTERN ADDITION BLOCK NO. 31

CITY AND COUNTY OF SAN FRANCISCO
SCALE: AS SHOWN

CALIFORNIA
SEPTEMBER, 2024



336 CLAREMONT BLVD. STE 1
SAN FRANCISCO, CA 94127
(415) 242-5400
www.westoversurveying.com

CONDOMINIUM GENERAL NOTES

- a) This map is the survey map portion of a condominium plan as described in California Civil Code Sections 4120 and 4285. This Condominium Project is limited to a maximum of thirty-five (35) Dwelling units.
- b) All ingress(es), egress(es), path(s) of travel, fire/emergency exit(s) and exiting components, exit pathway(s) and passageway(s), stairway(s), corridor(s), elevator(s), and common use accessible feature(s) and facilities such as restrooms that the Building Code requires for common use shall be held in common undivided interest.
- c) Unless specified otherwise in the governing documents of a condominium homeowners' association, including its conditions, covenants, and restrictions, the homeowners association shall be responsible, in perpetuity, for the maintenance, repair, and replacement of:
 - (i) All general use common area improvements; and
 - (ii) All fronting sidewalks, all permitted or unpermitted private encroachments and privately maintained street trees fronting the property, and any other obligation imposed on property owners fronting a public right-of-way pursuant to the Public Works Code or other applicable Municipal Codes.
- d) In the event the areas identified in (c) (ii) are not properly maintained, repaired, and replaced according to the City requirements, each homeowner shall be responsible to the extent of his/her proportionate obligation to the homeowners' association for the maintenance, repair, and replacement of those areas. Failure to undertake such maintenance, repair, and replacement may result in City enforcement and abatement actions against the homeowners' association and/or the individual homeowners, which may include, but not be limited to imposition of a lien against the homeowner's property.
- e) Approval of this map shall not be deemed approval of the design, location, size, density or use of any structure(s) or ancillary areas of the property associated with structures, new or existing, which have not been reviewed or approved by appropriate City agencies nor shall such approval constitute a waiver of the subdivider's obligation to abate any outstanding municipal code violations. Any structures constructed subsequent to approval of this Final Map shall comply with all relevant municipal codes, including but not limited to the planning, housing and building codes, in effect at the time of any application for required permits.
- f) Bay windows, fire escapes and other encroachments (if any shown hereon, that exist, or that may be constructed) onto or over Larkin Street and North Point Street are permitted through and are subject to the restrictions set forth in the Building Code and Planning Code of the City and County of San Francisco. This map does not convey any ownership interest in such encroachment areas to the condominium unit owner(s).
- g) Significant encroachments, to the extent they were visible and observed, are noted hereon. However, it is acknowledged that other encroachments from/onto adjoining properties may exist or be constructed. It shall be the responsibility solely of the property owners involved to resolve any issues that may arise from any encroachments whether depicted hereon or not. This map does not purport to convey any ownership interest in an encroachment area to any property owner.

THIS FINAL MAP IS SUBJECT TO:

- "Notice of Special Restrictions under The Planning Code" recorded December 30, 2019 as Document No. 2019-K884581 of Official Records.
- "Notice of Special Restrictions under The Planning Code" recorded March 18, 2022 as Document No. 2022028016 of Official Records.
- "Notice of Special Restrictions under The Planning Code" recorded March 01, 2023 as Document No. 2023015320 of Official Records.
- "Notice of Special Restrictions under The Planning Code" recorded November 14, 2023 as Document No. 2023089881 of Official Records.

BASIS OF SURVEY:

THE MONUMENT LINES SHOWN HEREON WERE LOCATED BY RECORD MEASUREMENTS FROM FOUND MONUMENTS AS SHOWN ON MONUMENT MAP #019A. ONLY 2 MONUMENT MARKS COULD BE FOUND TO ESTABLISH THE LARKIN STREET MONUMENT LINE. THE BAY STREET MONUMENT LINE WAS HELD AS THE BASIS FOR THIS SURVEY. THE NORTHERLY, SOUTHERLY AND EASTERLY BLOCK LINES WERE ESTABLISHED PARALLEL AND PERPENDICULAR TO THE MONUMENT LINES. THE WESTERLY BLOCK LINE WAS NOT ESTABLISHED ON THIS SURVEY, HOWEVER, A REFERENCE LINE IS SHOWN ON THIS SURVEY FOR THE PURPOSE OF RETRACEMENT TO THE FOUND "L" CUTS ON EASTERLY SIDE OF POLK STREET. THE NORTHERLY LINE OF BAY STREET WAS ESTABLISHED 62.75' OFFSET FROM THE BAY STREET MONUMENT LINE WHICH FITS RECORD NORTH-SOUTH DISTANCE TO ONE OF THE "L" CUTS ON POLK STREET AND BOTH FOUND TAGS ON LARKIN STREET PER {R6}. THE WESTERLY LINE OF LARKIN STREET WAS ESTABLISHED 6.00' OFFSET FROM THE LARKIN STREET MONUMENT LINE PER {R6}. THE SOUTHERLY LINE OF NORTH POINT STREET WAS ESTABLISHED AT 337.75' FROM THE BAY STREET MONUMENT LINE PER {R6}. THE POINT OF BEGINNING PER {R1} WAS ESTABLISHED ON THE SOUTHERLY LINE OF NORTH POINT STREET AT A DISTANCE OF 45.83' (45'-10") {R1} WESTERLY FROM THE WESTERLY LINE OF LARKIN STREET. THE SUBJECT LOT WAS ESTABLISHED PER RECORD DIMENSIONS OF {R1} BUT CONVERTED TO DECIMAL FEET ROUNDED TO THE NEAREST HUNDRETH.

FIELD SURVEY COMPLETION STATEMENT

THE FIELD SURVEY WAS COMPLETED ON 11/12/2019. ALL PHYSICAL DETAILS INCLUDING CITY AND PRIVATE MONUMENTATION SHOWN HEREON EXISTED AS OF THE FIELD SURVEY COMPLETION DATES, UNLESS OTHERWISE NOTED.

GENERAL NOTES:

- 1- ALL ANGLES ARE NINETY DEGREES UNLESS OTHERWISE NOTED.
- 2- ALL DISTANCES ARE IN TENTHS AND HUNDREDTHS OF FEET.
- 3- MEASURED DISTANCES EQUAL RECORD DISTANCES SHOWN ON REFERENCES UNLESS OTHERWISE NOTED.
- 4- MONUMENT MARKS PER {R2} WITHIN THE SUBJECT BLOCK NOT SHOWN HEREON WERE EITHER SFNF OR NOT ACCESSIBLE AT THE TIME OF THE SURVEY.
- 5- DIMENSIONS FROM PROPERTY LINES TO BUILDING CORNERS ARE FOR INFORMATIONAL PURPOSES ONLY AND ARE NOT TO BE USED FOR RETRACEMENT OF THIS SURVEY.
- 6- THE LARKIN STREET MONUMENT LINE HAS LESS THAN THREE TIES TO CITY MONUMENTS BECAUSE NO MORE MONUMENTS COULD BE FOUND TO REFERENCE THIS MONUMENT LINE.

UNIT NUMBERS & ASSESSOR PARCEL NUMBERS

THE PROPOSED ASSESSOR PARCEL NUMBERS SHOWN BELOW ARE FOR INFORMATIONAL USE ONLY AND SHOULD NOT BE RELIED UPON FOR ANY OTHER PURPOSE.

| UNIT NUMBER | PARCEL NUMBER |
|-------------|---------------|
| L101 | 0453-025 |
| L103 | 0453-026 |
| L104 | 0453-027 |
| NP101 | 0453-028 |
| NP102 | 0453-029 |
| L201 | 0453-030 |
| L202 | 0453-031 |
| L203 | 0453-032 |
| L204 | 0453-033 |
| NP201 | 0453-034 |
| NP202 | 0453-035 |
| NP203 | 0453-036 |
| NP204 | 0453-037 |
| NP205 | 0453-038 |
| NP206 | 0453-039 |
| L301 | 0453-040 |
| L302 | 0453-041 |
| L303 | 0453-042 |
| L304 | 0453-043 |
| NP301 | 0453-044 |
| NP302 | 0453-045 |
| NP303 | 0453-046 |
| NP304 | 0453-047 |
| NP305 | 0453-048 |
| NP306 | 0453-049 |
| NP307 | 0453-050 |
| L401 | 0453-051 |
| L402 | 0453-052 |
| L403 | 0453-053 |
| NP401 | 0453-054 |
| NP402 | 0453-055 |
| NP403 | 0453-056 |
| NP404 | 0453-057 |
| NP405 | 0453-058 |
| L501 | 0453-059 |

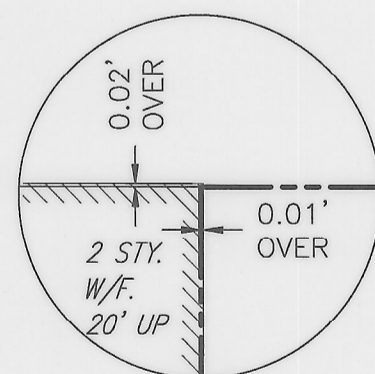

DETAIL "A"
SCALE: 1"=1'

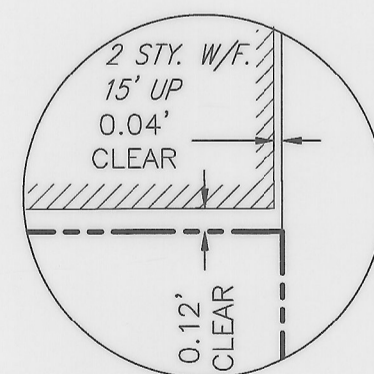

DETAIL "G"
SCALE: 1"=1'

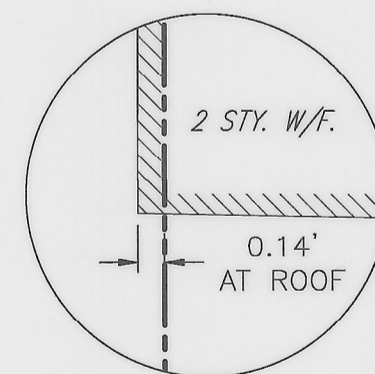

DETAIL "H"
SCALE: 1"=1'

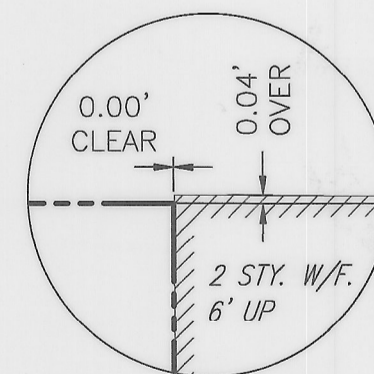

DETAIL "J"
SCALE: 1"=1'

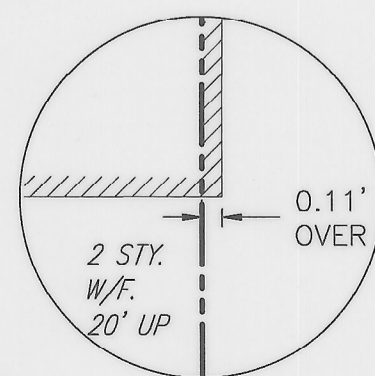

DETAIL "B"
SCALE: 1"=1'

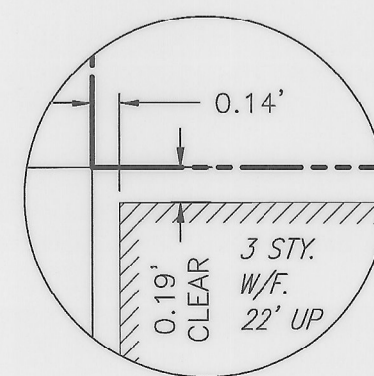

DETAIL "C"
SCALE: 1"=1'

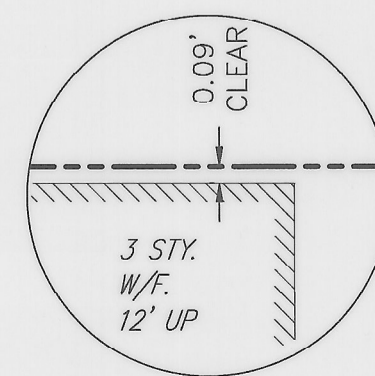

DETAIL "D"
SCALE: 1"=1'

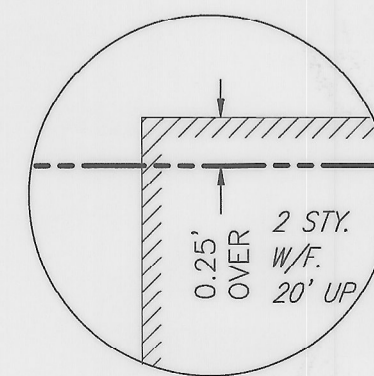

DETAIL "E"
SCALE: 1"=1'

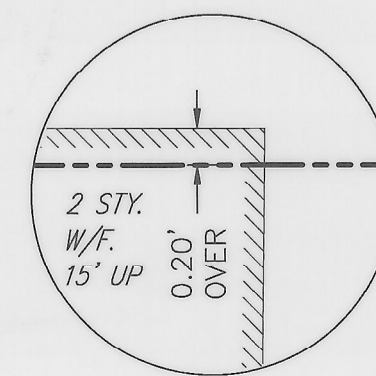

DETAIL "F"
SCALE: 1"=1'

FINAL MAP No. 12116

A 35 UNIT RESIDENTIAL CONDOMINIUM PROJECT

BEING A SUBDIVISION OF THAT REAL PROPERTY DESCRIBED IN THAT CERTAIN GRANT DEED RECORDED DECEMBER 17, 2019 IN DOCUMENT NO. 2019-K877891-00, RECORDER'S OFFICE OF THE CITY AND COUNTY OF SAN FRANCISCO.

BEING PART OF WESTERN ADDITION BLOCK NO. 31

CITY AND COUNTY OF SAN FRANCISCO
SCALE: AS SHOWN

CALIFORNIA
SEPTEMBER, 2024



336 CLAREMONT BLVD. STE 1
SAN FRANCISCO, CA 94127
(415) 242-5400
www.westoversurveying.com