

NOTE: REFER TO MICROTRENCHING STANDARD
FILE NO. 120,964 FOR MICROTRENCHING NOTES.

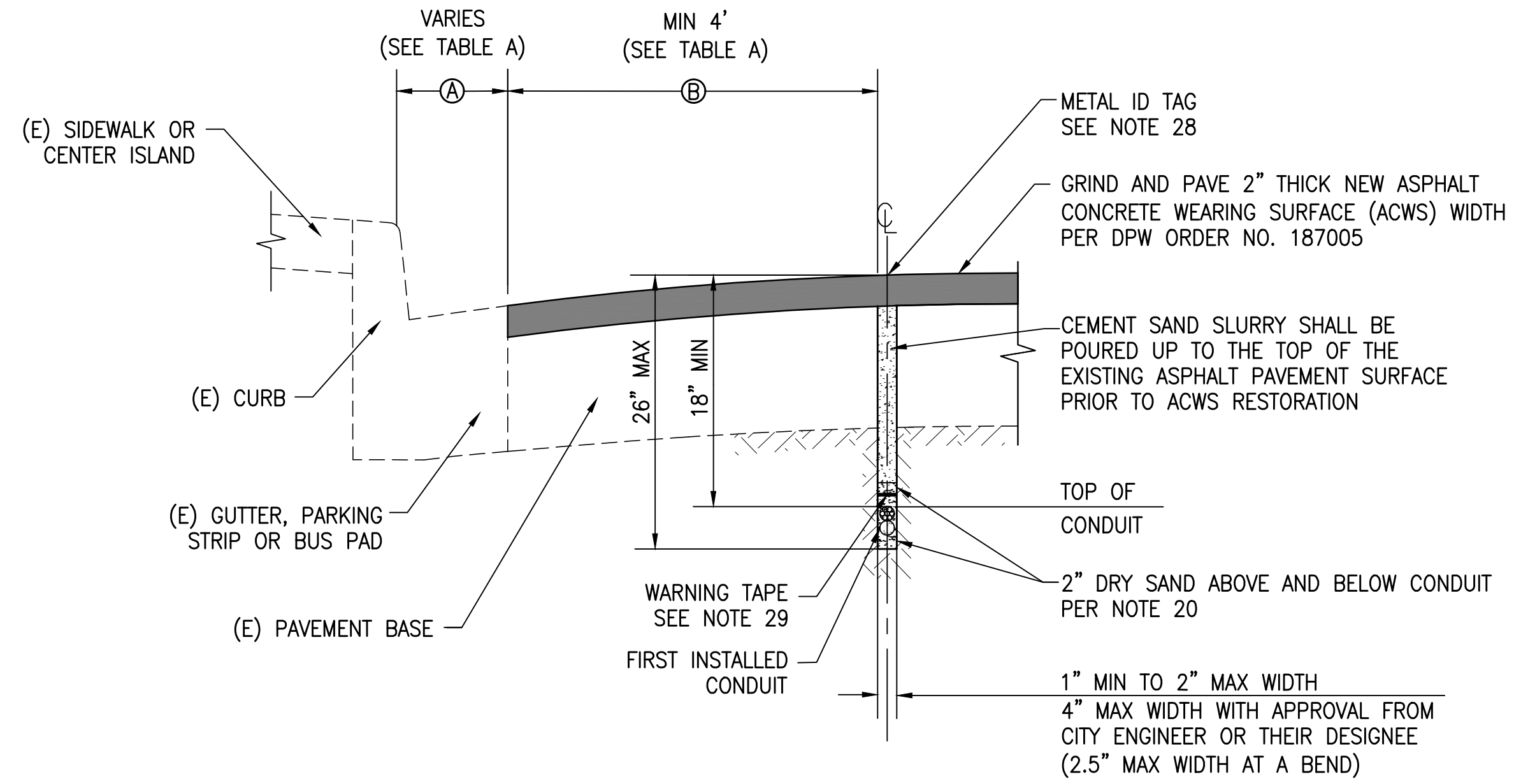

STANDARD DETAIL 1 - MICROTRENCH RESTORATION

ASPHALT CONCRETE WEARING SURFACE (ACWS)

SCALE: NTS

1

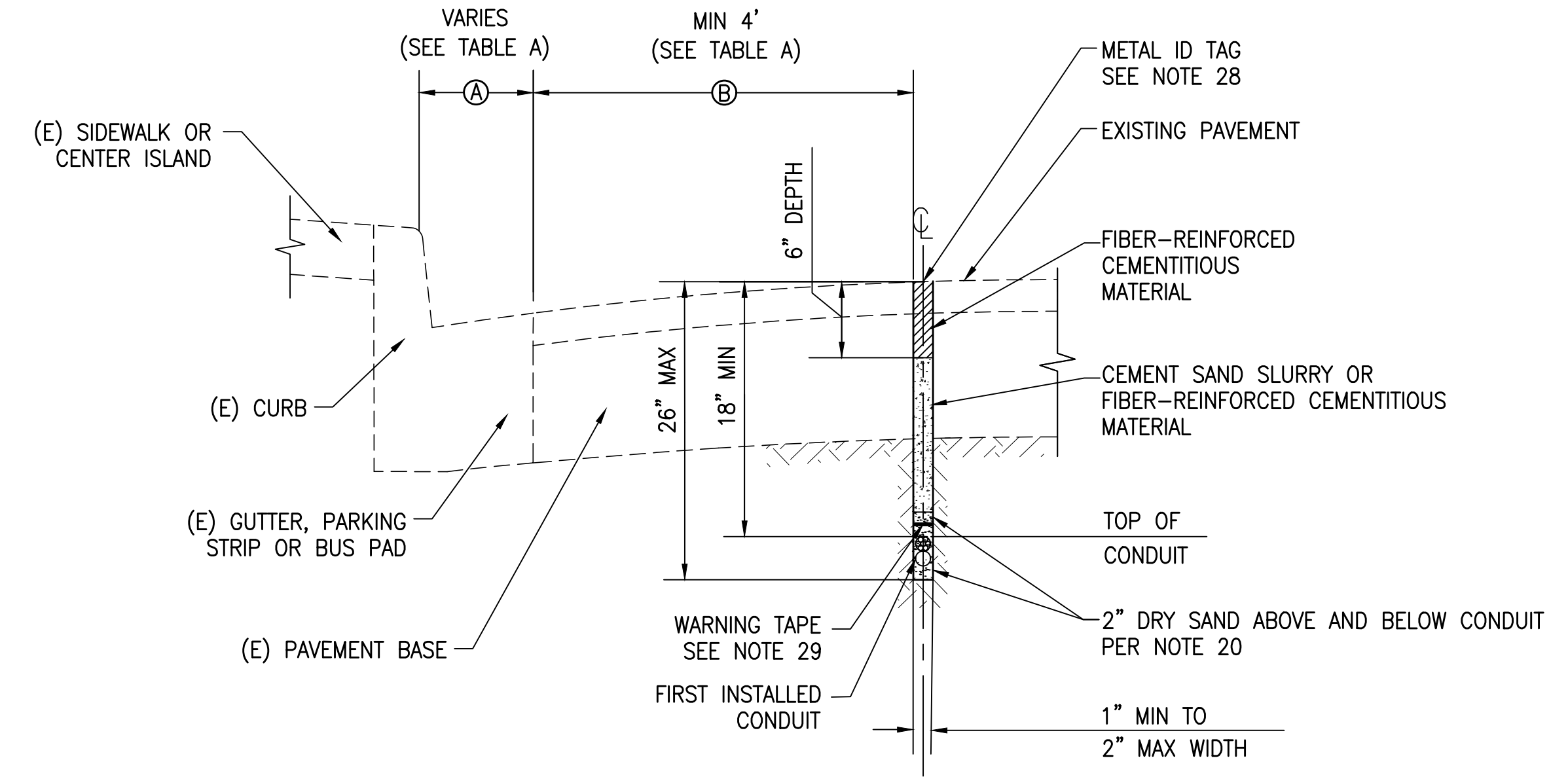

STANDARD DETAIL 2 - MICROTRENCH RESTORATION

FIBER-REINFORCED CEMENTITIOUS MATERIAL

SCALE: NTS

2

TABLE A - MICROTRENCH CLEARANCE REQUIREMENTS

EDGE OF PAVEMENT FEATURE	Ⓐ TYPICAL WIDTH FROM FACE OF CURB	Ⓑ MINIMUM DISTANCE TO EDGE OF MICROTRENCH
CURB ONLY FILE NO. 87,169	N/A	4' MIN FROM FACE OF CURB
GUTTER FILE NO. 87,170	1-3'	4' MIN FROM EDGE OF GUTTER
PARKING STRIP FILE NO. 87,170	5'-8'	4' MIN FROM EDGE OF PARKING STRIP
BUS PAD FILE NO. 96,607	10'	4' MIN FROM EDGE OF BUS PAD

TABLE B - MICROTRENCH MATERIAL REQUIREMENTS

FILL MATERIAL	PROPERTY	REQUIREMENT	ASTM TEST
DRY SAND	SAND EQUIVALENT	SE 50 OR BETTER	ASTM D2419
CEMENT SAND SLURRY (FLOWABLE SELF-CONSOLIDATING CONCRETE)	COMPRESSIVE STRENGTH	5000 PSI (MIN) @ 28 DAYS	ASTM C109
		2500 PSI (MIN) @ 1 DAY 5000 PSI (MIN) @ 28 DAYS	ASTM C109
FIBER-REINFORCED CEMENTITIOUS MATERIAL (MATERIAL COLOR SHALL MATCH ADJACENT PAVEMENT)	FLEXURAL STRENGTH	1450 PSI (MIN) @ 28 DAYS	ASTM C348
	BOND STRENGTH	2500 PSI (MIN) @ 28 DAYS	ASTM C882 (AS MODIFIED BY ASTM C928)
	SHRINKAGE (DRY CURE)	0.15% (MAX)	ASTM C157

NO.	DATE	DESCRIPTION	BY	APP.
TABLE OF REVISIONS				

REFERENCE INFORMATION
& FILE NO. OF SURVEYS



BUREAU OF ENGINEERING
CITY & COUNTY OF SAN FRANCISCO
SAN FRANCISCO PUBLIC WORKS
49 SOUTH VAN NESS AVENUE, Suite 800
SAN FRANCISCO, CA 94103

Acting Section Mgr: DEANNA CALLEROS
Deanna Calleros
Date: 07/10/2023
Acting Bureau Mgr: IQBAL DHAPA
Iqbal Dhapa
Date: 07/10/2023
City Engineer: ALBERT KO
Albert Ko
Date: 07/12/2023

DESIGNED: DATE: PUBLIC WORKS 4/23
DRAWN: DATE: PUBLIC WORKS 4/23
CHECKED: DATE: PUBLIC WORKS 4/23

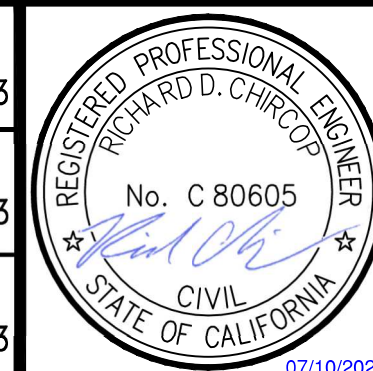

SCALE:
NOT TO SCALE
SHEET OF SHEETS
2 OF 2

MICROTRENCHING STANDARD
MICROTRENCHING DETAILS AND TABLES

CONTRACT NO.
NONE
DRAWING NO.
MT-2
FILE NO.
120,965
REV. NO.

Dimension Scale: 1
Model Units: Inches
Measurement Units are English