

File No. 200701 Committee Item No. 1
 Board Item No. 2

COMMITTEE/BOARD OF SUPERVISORS
 AGENDA PACKET CONTENTS LIST

Committee: Land Use and Transportation Committee Date October 26, 2020
 Board of Supervisors Meeting Date November 10, 2020

Cmte Board

- | | | |
|-------------------------------------|-------------------------------------|--|
| <input type="checkbox"/> | <input type="checkbox"/> | Motion |
| <input type="checkbox"/> | <input type="checkbox"/> | Resolution |
| <input checked="" type="checkbox"/> | <input checked="" type="checkbox"/> | Ordinance |
| <input checked="" type="checkbox"/> | <input checked="" type="checkbox"/> | Legislative Digest |
| <input type="checkbox"/> | <input type="checkbox"/> | Budget and Legislative Analyst Report |
| <input type="checkbox"/> | <input type="checkbox"/> | Youth Commission Report |
| <input checked="" type="checkbox"/> | <input checked="" type="checkbox"/> | Introduction Form |
| <input type="checkbox"/> | <input type="checkbox"/> | Department/Agency Cover Letter and/or Report |
| <input type="checkbox"/> | <input type="checkbox"/> | MOU |
| <input type="checkbox"/> | <input type="checkbox"/> | Grant Information Form |
| <input type="checkbox"/> | <input type="checkbox"/> | Grant Budget |
| <input type="checkbox"/> | <input type="checkbox"/> | Subcontract Budget |
| <input type="checkbox"/> | <input type="checkbox"/> | Contract/Agreement |
| <input type="checkbox"/> | <input type="checkbox"/> | Form 126 – Ethics Commission |
| <input type="checkbox"/> | <input type="checkbox"/> | Award Letter |
| <input type="checkbox"/> | <input checked="" type="checkbox"/> | Application |
| <input checked="" type="checkbox"/> | <input type="checkbox"/> | Public Correspondence |

OTHER (Use back side if additional space is needed)

- | | | |
|-------------------------------------|-------------------------------------|--|
| <input checked="" type="checkbox"/> | <input checked="" type="checkbox"/> | <u>Referral CEQA 070820</u> |
| <input checked="" type="checkbox"/> | <input checked="" type="checkbox"/> | <u>Referral BIC 070820</u> |
| <input checked="" type="checkbox"/> | <input checked="" type="checkbox"/> | <u>CEQA Determination 070820</u> |
| <input checked="" type="checkbox"/> | <input checked="" type="checkbox"/> | <u>BIC Response 082120</u> |
| <input checked="" type="checkbox"/> | <input checked="" type="checkbox"/> | <u>COE Reso No. 002-20-COE</u> |
| <input checked="" type="checkbox"/> | <input checked="" type="checkbox"/> | <u>SF Enviro Racial Equity Analysis 091720</u> |
| <input checked="" type="checkbox"/> | <input checked="" type="checkbox"/> | <u>SF Enviro 063020</u> |
| <input checked="" type="checkbox"/> | <input checked="" type="checkbox"/> | <u>Dept of Enviro PPT 092120</u> |
| <input checked="" type="checkbox"/> | <input checked="" type="checkbox"/> | <u>DBI AB-112 091620</u> |
| <input checked="" type="checkbox"/> | <input checked="" type="checkbox"/> | <u>SF Environment Findings June 2020</u> |
| <input type="checkbox"/> | <input checked="" type="checkbox"/> | <u>_____</u> |
| <input type="checkbox"/> | <input type="checkbox"/> | <u>_____</u> |

Completed by: Erica Major Date October 22, 2020
 Completed by: Erica Major Date October 28, 2020

1 [Building Code, Environment Code - Mandating New Construction Be All-Electric]

2

3 **Ordinance amending the Building Code to require new construction to utilize only**
4 **electric power; amending Environment Code to provide public hearings on**
5 **implementation of all-electric requirement; adopting findings of local conditions under**
6 **the California Health and Safety Code; affirming the Planning Department’s**
7 **determination under the California Environmental Quality Act; and directing the Clerk**
8 **of the Board of Supervisors to forward this ordinance to the California Building**
9 **Standards Commission upon final passage.**

10 NOTE: **Unchanged Code text and uncodified text** are in plain Arial font.
11 **Additions to Codes** are in *single-underline italics Times New Roman font*.
12 **Deletions to Codes** are in *strikethrough italics Times New Roman font*.
13 **Board amendment additions** are in double-underlined Arial font.
14 **Board amendment deletions** are in ~~strikethrough Arial font~~.
15 **Asterisks (* * * *)** indicate the omission of unchanged Code
16 subsections or parts of tables.

17 Be it ordained by the People of the City and County of San Francisco:

18

19 Section 1. General Findings.

20 (a) The Planning Department has determined that the actions contemplated in this
21 ordinance comply with the California Environmental Quality Act (California Public Resources
22 Code Sections 21000 et seq.). Said determination is on file with the Clerk of the Board of
23 Supervisors in File No. 200701 and is incorporated herein by reference. The Board affirms
24 this determination.

25 (b) On August 19, 2020, the Building Inspection Commission considered this
ordinance at a duly noticed public hearing pursuant to Charter Section D3.750-5.

1 Section 2. Findings Regarding Local Conditions.

2 (a) California Health and Safety Code Sections 17958.7 and 18941.5 provide that local
3 jurisdictions may enact more restrictive building standards than those contained in the
4 California Building Code, provided that the local jurisdictions make express findings that each
5 change or modification is reasonably necessary because local climate, geologic, or
6 topographical conditions and that the local jurisdictions file the local amendments and
7 required findings with the California Building Standards Commission before the local changes
8 or modifications can go into effect.

9 (b) The Board of Supervisors hereby finds and declares that the following
10 amendments to the San Francisco Building Code are reasonably necessary because of local
11 climatic, topological, and geological conditions as discussed below.

12 (1) The topography of San Francisco creates increased risk of fire due to
13 high density of buildings on very small lots and high population density. It is necessary and
14 appropriate to stop building new natural gas infrastructure that increases acute and
15 cumulative fire risk across the City.

16 (2) San Francisco's geologic and topographic conditions produce increased
17 risk for earthquake-induced failure and consequent fire due to local hazardous seismic
18 microzones, slide areas, and local liquefaction hazards. Natural gas infrastructure may
19 rupture, fail, and/or explode due to earthquake-induced structural failure. After seismic
20 events, natural gas infrastructure will take significantly longer to resume service compared to
21 electrical infrastructure. It is necessary and appropriate to reduce fire risk and increase
22 resiliency by eliminating the construction of new natural gas infrastructure.

23 (3) San Francisco's climate and topography create wind patterns and
24 periodic seasonal high temperatures that produce smog and ozone that exacerbate the
25 respiratory ailments of residents. Natural gas combustion is a major source of indoor air

1 pollution that further exacerbates the effects of regional pollution for the City's residents and
2 can be particularly acute in the City's dense population and smaller dwelling units. Studies
3 have shown children living in homes with natural gas stoves have a 42% increased risk of
4 experiencing asthma symptoms and those impacts may be exacerbated in a compact city
5 such as San Francisco where low-income households are more likely to have more people
6 living in smaller spaces with less ventilation. It is reasonable and appropriate to decrease
7 pollution exposure and resulting human health impacts by utilizing All-Electric construction
8 instead of creating additional natural gas infrastructure.

9 (4) Human activities releasing greenhouse gases into the atmosphere cause
10 increases in worldwide average temperature, which contribute to melting of glaciers and
11 thermal expansion of ocean water. As a city located on the tip of a peninsula, surrounded on
12 three sides by water, San Francisco is experiencing and will continue to experience the
13 repercussions of climate change such as extreme heat events and rising sea levels causing
14 significant erosion, increasing impacts to infrastructure during extreme tides, and causing the
15 City to expend funds to modify its infrastructure.

16 (5) The operation of buildings comprises a significant portion of the City's
17 greenhouse gas emissions. In 2017, the operation of buildings was responsible for 43.7% of
18 citywide greenhouse gas emissions. The City has grown considerably in recent years. For
19 example, since 1990 the economy of the City grew 162% and population increased by 22%.
20 This growth results in construction of new buildings and significant rehabilitation of existing
21 buildings.

22 (6) San Francisco's electric system increasingly utilizes renewable energy.
23 Emissions of carbon dioxide per megawatt hour of electricity delivered to the City have
24 decreased by 78% since 1990. The City has set a goal of ensuring that 100% of electricity
25 usage citywide is generated via renewable, greenhouse gas-free sources by 2030. In 2017,

1 80% of greenhouse gas emissions from the operation of buildings citywide was due to
2 consumption of natural gas or district steam produced via combustion of natural gas.

3 (7) The primary constituent of natural gas is methane, which is 86 times
4 more potent of a greenhouse gas than carbon dioxide. In addition, more than 4% of methane
5 leaks into the atmosphere prior to delivery.

6 (8) It is necessary and appropriate to stop construction of new natural gas
7 infrastructure in San Francisco in order to reduce the unique impacts San Francisco will
8 endure from global warming.

9 (c) The Board of Supervisors hereby also finds that the City values the diverse
10 restaurant community that makes the City a vibrant center of both culinary innovation and
11 traditional cuisines that are critical to the cultural integrity, identity, and economic vitality of
12 San Francisco. While electric cooking technology is widely and increasingly available, the
13 Board of Supervisors finds that the potential for deleterious impacts to restaurant enterprises
14 is sufficiently present, particularly in light of the severe economic disruption posed by the 2020
15 COVID-19 pandemic, that an additional transition period and process for seeking an exception
16 for such enterprises that may be included in a new construction project is prudent,
17 appropriate, and necessary for the public welfare.

18
19 Section 3. The Building Code is hereby amended by revising Sections 106A and 202,
20 to read as follows:

21 **SECTION 106A – PERMITS**

22 * * * *

23 **106A.1.16.3 Inspections.** Inspections by the Electrical Division are required for EV
24 Charging Station installations, and for any alteration or modification of the electrical system on
25 the property, including the installation of EVSE.

1 **106A.1.17 Mixed-Fuel Buildings.** The Building Official shall not issue permits for
2 construction of any new Mixed-Fuel Buildings that submitted ~~an~~their initial application on or after
3 January 1, 2021. Permits for new construction that submit ~~their~~ initial applications on or after that
4 date may only be obtained for All-Electric Buildings or Projects. For purposes of this subsection,
5 the initial application shall be the first site or building permit application associated with the
6 project.

7 **EXCEPTIONS:** The Building Official may issue a permit for construction of a new Mixed-Fuel
8 Building in the following circumstances, and provided that the building shall be Electric-Ready as
9 specified in the Design Guidelines for Electric-Ready Buildings published by the Department
10 of Building Inspection:

11 (1) Upon the Building Official’s finding that constructing an All-Electric Building or Project is
12 physically or technically infeasible and that a modification pursuant to section 104A.2.7 is warranted.
13 Financial considerations shall not be a sufficient basis to determine physical or technical
14 infeasibility. Modifications from this section 106A.1.17 shall only be issued under this exception
15 where the Building Official finds: sufficient evidence was submitted to substantiate the infeasibility of
16 an All-Electric Building or Project design; the installation of natural gas piping systems, fixtures
17 and/or infrastructure is strictly limited to the system and area of the building for which All-Electric
18 Building or Project design is infeasible; ~~the area or service within the project where gas piping~~
19 systems, fixtures and/or infrastructure are installed is as Electric-Ready as feasibly possible
20 considering other provisions of the Building and Electrical Codes; and that the project’s modified
21 design provides equivalent health, safety and fire-protection to All-Electric Building or Project design;
22 or

23 (2) The Building Official may issue a permit for a new Mixed Fuel Building that includes an
24 area specifically designated for occupancy by a commercial food service establishment (A-2
25 Occupancy) that is a Mixed-Fuel Building solely because it provides gas piping systems, fixtures and/or

1 infrastructure exclusively for cooking equipment within the designated commercial food service area
2 where the initial application was submitted prior to January 1, 2022.

3 (i) For initial applications submitted on or after this date, the Building Official
4 may issue a permit for such a new Mixed-Fuel Building—that is a Mixed-Fuel Building solely
5 because it provides gas piping systems, fixtures and/or infrastructure exclusively for cooking
6 equipment within the designated commercial food service area—upon finding that the
7 applicant has submitted sufficient evidence that such gas systems are necessary for the
8 specific commercial food service establishment that will operate the food service area.
9 Applicants may appeal determinations made by the Building Official to the Board of
10 Examiners, pursuant to section 105A.1.

11 **REPORTING:** No later than July 15, 2021 and annually thereafter until 2025, the
12 Building Official shall provide to the Department of Environment a report listing the status of all
13 permits granted or in process to construct a new Mixed-Fuel Building pursuant to the above
14 exceptions. The reports shall be cumulative and shall include a brief description of the
15 circumstances for which the applicant seeks or has been granted an exception.

16 **106A.1.17.1 Conversion to Mixed-Fuel Buildings.** The Building Official shall not issue
17 permits that would convert an All-Electric Building or Project into a Mixed-Fuel Building where the
18 initial application was submitted after January 1, 2021.

19 **106A.1.17.2 Municipal New Construction** ~~or Major Renovation Projects.~~ The provisions in
20 section 106A.1.17 do not apply to Municipal New Construction ~~or Major Renovation Projects~~ as
21 defined by Chapter 7 of the Environment Code that are subject to Section 706 of the Environment
22 Code.

23
24 * * * *
25

1 **SECTION 202 – DEFINITIONS**

2 Add these definitions as follows:

3 **ALL-ELECTRIC BUILDING OR PROJECT.** *A building or project that uses a permanent*
4 *supply of electricity as the source of energy for all space conditioning (including heating and cooling),*
5 *water heating (including pools and spas), cooking appliances, and clothes drying appliances. An All-*
6 *Electric Building or Project may not install natural gas or propane piping systems, fixtures or*
7 *infrastructure for those purposes in or in connection with the building, structure, or within property*
8 *lines of the premises, extending from the point of delivery at the gas meter.*

9 * * * *

10 **ELECTRIC-READY.** *A building, project, or portion thereof that contains electrical systems*
11 *and designs that provide capacity for a future retrofit of a Mixed-Fuel Building to an All-Electric*
12 *Building. Electric-Ready includes sufficient space, drainage, electrical conductors or raceways, bus*
13 *bar capacity, and overcurrent protective devices to provide capacity for a future retrofit to an All-*
14 *Electric Building as specified in the Design Guidelines for Electric-Ready Buildings published*
15 *by the Department of Building Inspection.*

16 * * * *

17 **MIXED-FUEL BUILDING.** *A building that uses natural gas or propane as fuel for space*
18 *heating or cooling, exterior heating, decorative uses and lighting, water heating (including pools*
19 *and spas), cooking appliances or clothes drying appliances, onsite generation of electricity (except*
20 *where primarily fueled by onsite digestion of organic material), or contains fixtures, piping systems, or*
21 *infrastructure for natural gas or propane equipment for such uses.*

22
23 Section 4. The Environment Code is hereby amended by adding Section 909, to
24 read as follows:

25 **SEC. 909. IMPLEMENTATION OF ALL-ELECTRIC BUILDING STANDARD.**

1 (a) The Department of Environment shall coordinate with the Department of
2 Building Inspection in implementation of the All-Electric building requirement in Section
3 106A.1.17 of the Building Code.

4 (b) The Department of Environment shall hold at least one public meeting annually
5 to discuss the annual report from the Department of Building Inspection detailing the status of
6 applications for permits to construct new Mixed-Fuel Buildings pursuant to an exception to
7 Building Code Section 106A.1.17.

8
9 Section 5. Preexisting Rights Unaffected. Nothing in this Ordinance is intended to
10 impair or limit any contract right that exists as of the Effective Date of this Ordinance. In
11 connection with the application of this Ordinance as it relates to development agreements or
12 similar contracts, or approved development plans administered by the Office of Community
13 Investment and Infrastructure, the Department of Building Inspection shall consult with the
14 City Attorney to determine whether the denial of a permit or approval will violate the terms of
15 contracts that the City entered into before the Effective Date of this Ordinance.

16
17 Section 64. Effective Date. This ordinance shall become effective 30 days after
18 enactment. Enactment occurs when the Mayor signs the ordinance, the Mayor returns the
19 ordinance unsigned or does not sign the ordinance within ten days of receiving it, or the Board
20 of Supervisors overrides the Mayor's veto of the ordinance.

21
22 Section 75. Scope of Ordinance. In enacting this ordinance, the Board of Supervisors
23 intends to amend only those words, phrases, paragraphs, subsections, sections, articles,
24 numbers, punctuation marks, charts, diagrams, or any other constituent parts of the Municipal
25 Code that are explicitly shown in this ordinance as additions, deletions, Board amendment

1 additions, and Board amendment deletions in accordance with the “Note” that appears under
2 the official title of the ordinance.

3
4 Section 86. Severability. If any section, subsection, sentence, clause, or phrase of this
5 ordinance is, for any reason, held to be invalid, such decision shall not affect the validity of the
6 remaining portions of this ordinance. The Board of Supervisors hereby declares that it would
7 have passed this ordinance, and each section, subsection, sentence, clause, or phrase of this
8 Ordinance, irrespective of the fact that any one or more sections, subsections, sentences,
9 clauses, or phrases be declared invalid.

10
11 Section 97. Directions to Clerk. Upon final passage of this ordinance, the Clerk of the
12 Board of Supervisors is hereby directed to transmit this ordinance to the California Building
13 Standards Commission pursuant to the applicable provisions of State law.

14
15 APPROVED AS TO FORM:
16 DENNIS J. HERRERA, City Attorney

17 By: /s/ Robb W. Kapla
18 ROBB W. KAPLA
19 Deputy City Attorney

20
21
22
23
24
25
n:\legana\as2020\2000291\01486612.docx

REVISED LEGISLATIVE DIGEST
(Amended in Committee, 10/19/2020)

[Building Code, Environment Code - Mandating New Construction Be All-Electric]

Ordinance amending the Building Code to require new construction to utilize only electric power; amending Environment Code to provide public hearings on implementation of all-electric requirement; adopting findings of local conditions under the California Health and Safety Code; affirming the Planning Department's determination under the California Environmental Quality Act; and directing the Clerk of the Board of Supervisors to forward this ordinance to the California Building Standards Commission upon final passage.

Existing Law

The Building Code does not define or distinguish between all-electric buildings and mixed-fuel buildings or contain a definition of electric-ready design.

Amendments to Current Law

The proposed legislation would define the terms all-electric, mixed-fuel, and electric-ready in the Building Code. All-electric building or design is defined in the proposed legislation as a building that uses permanent electrical supply for air conditioning and heating, water heating, cooking appliances, and clothes drying appliances, and that does not contain any natural gas piping, fixtures, or infrastructure for those building needs. Natural gas piping, fixtures or infrastructure for other uses within a building, such as natural gas piping and appliances for industrial processes, would not disqualify a building as being all-electric for purposes of this legislation. The proposed legislation defines mixed-fuel buildings as buildings that utilize natural gas and/or contain natural gas piping, fixtures, or infrastructure for any of the following uses: air conditioning or heating, water heating, outdoor lighting or heating, decorative uses, cooking appliances, clothes drying, or electricity generation. The proposed legislation defines electric-ready as a building that contains sufficient electrical systems and design that would allow for future retrofit to all-electric design.

The proposed legislation would prohibit the Department of Building Inspection (DBI) from issuing building permits for construction of new mixed-fuel buildings where the initial application for the permit was submitted on or after January 1, 2021. The initial application would include the first site or building permit application associated with the project. It would also prohibit issuance of permits that would result in converting existing all-electric buildings to mixed-fuel buildings—for example, by adding natural gas piping for space heating to a building that currently only uses electricity for space heating—where the initial applications were submitted on or after January 1, 2021.

The proposed legislation contains two exceptions to the all-electric building requirement and under both exceptions, the building must be constructed to be as electric ready as feasible. The first exception is based on the Building Code's modification process and allows DBI to issue a permit to construct a new mixed-fuel building where all-electric design is physically or technically infeasible. DBI may only issue a permit under this modification process where it finds: (1) that complete all-electric design is physically or technically infeasible; (2) the installation of natural gas piping, fixtures and infrastructure is limited within the building to the space and use for which all-electric design is infeasible (for example, if electric water heating is infeasible, a natural gas water heater and piping is allowed and no other piping or fixtures may be installed in other locations serving other uses in the building); and (3) the modified, mixed-fuel design of the building provides equivalent health, safety, and fire protection as all-electric design.

The second exception provides an additional year to submit initial applications for new buildings that include a designated space for commercial food service establishments (restaurants). This exception allows DBI to issue permits for new construction of mixed-fuel buildings where initial applications are submitted before January 1, 2022, and the new building seeks natural gas piping, fixtures and infrastructure solely to accommodate a commercial food service establishment and where the use of natural gas is confined to cooking equipment in the food service area of the building. For initial applications submitted on or after January 1, 2022, DBI may issue a building permit for construction of a new mixed-fuel building (where the building is mixed-fuel solely due to the installation of natural gas piping, fixtures and infrastructure for the restaurant space operation) only upon finding that the applicant established that natural gas is necessary for the specific restaurant occupying the food service area.

The proposed legislation requires DBI to compile a list of all projects that seek or have been granted an exception to the all-electric requirement and provide that list to the Department of Environment annually on or before the 15th of July through the year 2025. The proposed legislation would require the Department of Environment to hold at least one public meeting annually to discuss the report from DBI.

Background Information

Natural gas combustion, infrastructure, and transport create significant health, safety, and environmental risks for San Francisco. The City's unique topography, high population density, stock of older wooden structures, seismic activity, and wind patterns make the City vulnerable to fast spreading fires triggered or strengthened by gas leaks and explosions. Indoor use of natural gas is also a significant contributor to indoor air pollution, the health impacts of which are exacerbated in denser developments with smaller dwelling units that make up a significant portion of the City's housing stock. Production, transportation, and combustion of natural gas are also significant contributors to climate change, which poses unique risks to the City in the form of sea level rise, extreme heat, and increasing storm frequency.

The objective of the proposed legislation is to recognize the health, safety, and environmental impacts of mixed-fuel buildings and ensure that new construction does not exacerbate these impacts. The proposed legislation would create new building standards in the Building Code, which requires: (1) that the standards are more protective than the California Building Code, (2) findings that the standards are based on unique geologic or environmental conditions, and (3) the standards are submitted to the California Building Standards Commission for review. The proposed legislation also contains findings explaining the basis for the extension and exception process for restaurants.

The proposed legislation follows other recent legislative efforts to address the risks and impacts of natural gas, including amendments to the Environment Code to mandate new municipal construction be all-electric, and amendments to the Green Building Code creating different energy efficiency standards for mixed-fuel and all-electric buildings.

n:\legana\as2020\2000291\01487072.docx

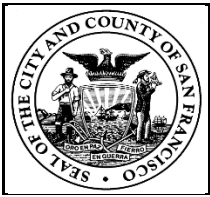

BUILDING INSPECTION COMMISSION (BIC)

Department of Building Inspection Voice (628) 652-3510
49 South Van Ness Avenue, 5th Floor, San Francisco, California 94103

London N. Breed
Mayor

August 21, 2020

COMMISSION

Angus McCarthy
President

Sam Moss
Vice-President

Alysabeth
Alexander-Tut
Kevin Clinch
Jon Jacobo
Jason Tam

Sonya Harris
Secretary

Patrick O’Riordan
Interim Director

Ms. Angela Calvillo
Clerk of the Board
Board of Supervisors, City Hall
1 Dr. Carlton B. Goodlett Place, Room 244
San Francisco, CA 94102-4694

Dear Ms. Calvillo:

RE: File No. 200701

Ordinance amending the Building Code to require new construction to utilize only electric power; adopting findings of local conditions under the California Health and Safety Code; affirming the Planning Department’s determination under the California Environmental Quality Act; and directing the Clerk of the Board of Supervisors to forward this Ordinance to the California Building Standards Commission upon final passage.

The Building Inspection Commission met and held a public hearing on August 19, 2020 regarding File No. 200701 on the proposed amendment to the Building Code referenced above. The Commissioners voted unanimously to **recommend approval** of the proposed Ordinance.

The Commissioners recommended that the ordinance be amended to include outdoor and decorative uses of natural gas in the definition of mixed-fuel projects, as proposed by the sponsor.

President McCarthy	Yes	Vice-President Moss	Yes
Commissioner Clinch	Yes	Commissioner Jacobo	Yes
Commissioner Tam	Yes		
Commissioner Alexander-Tut	Yes		

Should you have any questions, please do not hesitate to call me at (628) 652-3510.

Sincerely,

A handwritten signature in blue ink that reads "Sonya Harris". The signature is written in a cursive, flowing style.

Sonya Harris
Commission Secretary

cc: Patrick O'Riordan, Interim Director
Mayor London N. Breed
Supervisor Rafael Mandelman
Board of Supervisors

BOARD of SUPERVISORS

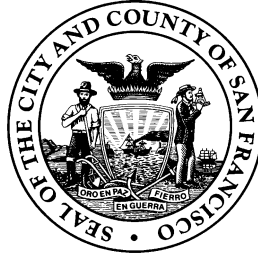

City Hall
Dr. Carlton B. Goodlett Place, Room 244
San Francisco 94102-4689
Tel. No. 554-5184
Fax No. 554-5163
TDD/TTY No. 554-5227

July 8, 2020

File No. 200701

Lisa Gibson
Environmental Review Officer
Planning Department
1650 Mission Street, Ste. 400
San Francisco, CA 94103

Dear Ms. Gibson:

On June 30, 2020, Supervisor Mandelman submitted the following legislation:

File No. 200701

Ordinance amending the Building Code to require new construction to utilize only electric power; adopting findings of local conditions under the California Health and Safety Code; affirming the Planning Department's determination under the California Environmental Quality Act; and directing the Clerk of the Board of Supervisors to forward this Ordinance to the California Building Standards Commission upon final passage.

This legislation is being transmitted to you for environmental review.

Angela Calvillo, Clerk of the Board

A handwritten signature in cursive script, appearing to read "Erica Major".

By: Erica Major, Assistant Clerk
Land Use and Transportation Committee

Attachment

c: Joy Navarrete, Environmental Planning
Don Lewis, Environmental Planning

Not defined as a project under CEQA Guidelines Sections 15378 and 15060(c)(2) because it would not result in a direct or indirect physical change in the environment.

07/08/2020

A handwritten signature in cursive script, appearing to read "Joy Navarrete".

1 [Support of Building Code - Mandating New Construction Be All-Electric, File Number: **200701**]

2

3 **Resolution urging the Board of Supervisors and the Mayor to adopt File Number 200701, an**
4 **Ordinance amending the Building Code to require new construction to exclude natural gas and**
5 **include exclusively all-electric energy sources;**

6 WHEREAS, the City and County of San Francisco has a duty to promote safety, improve the
7 health of its citizens, and enhance and protect our City’s natural environment; and

8 WHEREAS, San Francisco’s geologic and topographic conditions create safety challenges due
9 to increased risk for earthquake-induced failure; and,

10 WHEREAS, this same challenging topography also creates increased risk of fire due to high
11 density of buildings on very small lots and high population density; and,

12 WHEREAS, natural gas infrastructure may rupture, fail, and/or explode due to earthquake-
13 induced structural failure; and,

14 WHEREAS, the addition of new natural gas infrastructure in newly constructed buildings
15 increases acute and cumulative fire risk across the City; and,

16 WHEREAS, the elderly, the poor, young children, those with pre-existing medical conditions,
17 and communities of color are the most likely to suffer disproportionately from the health impacts of
18 climate change and may lack the resources to recover quickly from climate-related disasters; and,

19 WHEREAS, the combustion of natural gas emits a wide range of air pollutants, such as carbon
20 monoxide, nitrogen oxide, and particulate matter which have been linked to various acute and chronic
21 health effects including asthma in children, respiratory illness, cardiovascular disease, and premature
22 death; and,

23 WHEREAS, low-income communities and communities of color spend a disproportionate
24 amount of their income on energy and are more likely to suffer from asthma due to poor indoor air
25 quality; and

1 WHEREAS, the San Francisco Commission on the Environment seeks to improve, enhance,
2 and preserve the environment and to promote San Francisco's long-term environmental sustainability
3 as set forth in Section 4.118 of the City Charter; and,

4 WHEREAS, climate change has already affected San Francisco to varying degrees including
5 poor air quality from wildfires, drought, flooding, and extreme heat; and,

6 WHEREAS, production, transportation, and combustion of natural gas are also significant
7 contributors to climate change, which poses unique risks to the City in the form of sea level rise,
8 extreme heat, and increased frequency of extreme storms and droughts; and,

9 WHEREAS, the operation of buildings in 2018, was responsible for 44% of citywide
10 greenhouse gas emissions; and,

11 WHEREAS, in 2017, 80% of greenhouse gas emissions from the operation of buildings
12 citywide was due to consumption of natural gas or district steam produced via combustion of natural
13 gas; and,

14 WHEREAS, San Francisco has established an ambitious goal of achieving net zero emissions
15 by 2050 in order to do its part to stabilize the planet and protect the health of its residents; and,

16 WHEREAS, San Francisco continues to be a global climate action leader, having already met
17 City goals by reducing greenhouse gas emissions 35% from 1990 levels by 2018, while the City's
18 economy has grown 172% and its population has increased 22% during that time; and,

19 WHEREAS, reducing reliance on natural gas systems improves building safety, reduces fire
20 risk, and simplifies building systems and maintenance; and

21 WHEREAS, requiring energy-efficient and all-electric systems in buildings at the time of new
22 construction is more cost-effective than replacing equipment in good working order; and

23 WHEREAS, to achieve the City's goal of net zero emissions, it is necessary to discontinue the
24 installation of equipment dependent on fossil fuels, and instead, install high-efficiency equipment that
25 uses electricity and does not emit greenhouse gas; and,

1 WHEREAS, zero-emissions buildings benefit the safety, health, and welfare of San Francisco
2 and its residents by improving indoor air quality, alleviating conditions aggravating asthma, and
3 reducing harmful greenhouse gas emissions from energy consumption; now, therefore, be it,

4 RESOLVED, that the Commission on the Environment urges the Board of Supervisors and the
5 Mayor to adopt File Number 200701, an ordinance to reduce safety, health, and environmental risk by
6 eliminating the use of natural gas in new construction ; and, be it,

7 FURTHER RESOLVED, that the Commission on the Environment urges the Board of
8 Supervisors and the Mayor to continue to support policies that help San Francisco reach its goal of
9 achieving net zero emissions from all buildings by 2050.

10

11 I hereby certify that this Resolution was adopted by the Commission on the Environment at its
12 meeting on July 28, 2020.

13

14



15 Charles Sheehan, Chief Policy and Public Affairs Officer

16

17 Vote: 7-0 Approved

18 Ayes: Commissioners Stephenson, Ahn, Bermejo, Chu, Sullivan, Wald, and Wan

19 Noes: None

20 Absent: None



Context

Proposed Ordinance: All-Electric Buildings for New Construction

The proposed ordinance will update the San Francisco building code to require all new building permits submitted to the Department of Building Inspection (DBI) after January 1, 2021 be all-electric. All-electric buildings exclusively use electricity for power and do not contain any natural gas piping, fixtures, or infrastructure for air conditioning, heating, water heating, cooking appliances, and clothes drying appliances.

The goals of the ordinance are to increase building safety, improve indoor air quality, and reduce San Francisco's greenhouse gas (GHG) emissions. There is an exception process in the event that a project sponsor demonstrates it is infeasible to build all-electric. In the policy brief for the proposed ordinance, improved indoor air quality was identified as an equity and health benefit.¹ This analysis identifies additional racial equity concerns and recommendations, on the premise that if a policy is not intentionally designed to advance racial equity, then it is unlikely to do so.

Racial Disparities in San Francisco

Across every social indicator, when data is disaggregated by race, the legacy of more than 200 years of racially discriminatory government policies is evident in San Francisco. Racial disparities can be measured in unemployment, health, household income, housing and displacement, criminal justice, police violence, homelessness, education, and composition of the City and County of San Francisco's workforce.² Climate change exacerbates these disparities. People of color and lower income populations are least responsible for, yet most vulnerable to the impacts of climate change.

Racial Equity Analysis

As part of its Racial Equity Initiative, the San Francisco Department of Environment (SFE) will evaluate and provide recommendations for legislation to better advance racial equity. The process with which these recommendations will be communicated to stakeholders and policy makers is still under development. SFE's final process will follow the Office of Racial Equity's policy analysis tool, which is being developed for Board of Supervisors legislation.

For the proposed ordinance, *All-Electric Buildings for New Construction*, SFE racial equity staff identified five areas of analysis and short- and long-term recommendations to address concerns. Long-term recommendations require collaboration with other departments and outside entities and funding; several long-term recommendations make sense at a larger scale, beyond the proposed ordinance alone.

¹ https://sfenvironment.org/sites/default/files/fliers/files/sfe_zebtbf_new_construction_policy_brief.pdf

² <https://sfgov.legistar.com/View.ashx?M=F&ID=7586870&GUID=9E0222B9-7A4D-4082-8CCE-3F397520FC82>



Summary Table: Equity Analysis and Recommendations

Analysis	Description	Recommendations to Advance Racial Equity
<p>1) Energy Cost Burdens for Tenants</p>	<p>Higher utility bills disproportionately burden lower income populations. While information was provided about projected savings for lifetime of the building, utility cost comparison (electric vs mixed fuel) for tenants for short term was not provided.</p>	<ul style="list-style-type: none"> • <u>Short-term</u>: Conduct post-occupancy evaluation of utility costs for tenants and compile best practices to better understand any impacts and reduce costs in general. • <u>Long-term</u>: Work with utility regulators and providers to facilitate equitable rate structures. Develop educational materials for tenants about peak electricity pricing and opportunities to reduce energy costs. Subsidies, incentives, and/or other financial assistance could be expanded for energy efficiency, solar, and/or other technologies to ensure affordability for lower income tenants.
<p>2) Affordable Housing</p>	<p>Housing unaffordability disproportionately harms people of color. It is important to ensure all-electric construction continues to support affordable housing.</p>	<ul style="list-style-type: none"> • <u>Short-term</u>: Focus outreach and technical assistance to affordable housing developers who are unfamiliar or inexperienced with building electrification. • <u>Long-term</u>: Feedback mechanism is needed to understand impacts of the all-electric ordinance.
<p>3) Workforce Considerations</p>	<p>There is significant income inequality by race. Historically the green building industry has not been racially diverse. Jobs in building electrification will not solve all income inequality but can contribute toward closing the gap if they are designed to do so.</p>	<ul style="list-style-type: none"> • <u>Short-term</u>: Focus outreach and technical assistance to Black, Indigenous, and People of Color (BIPOC)-owned businesses and racial/ethnic affinity professional organizations to increase competitive advantage. • <u>Long-term</u>: Workforce training targeting BIPOC and people with barriers to employment is needed. Incentives and/or requirements to hire graduates of the training and to direct work to BIPOC-owned businesses are needed. Partnerships between SFE and workforce development agencies and non-profits need to be established to support this long-term vision.
<p>4) Restaurants</p>	<p>Cooking on an open gas flame impacts some cultural cooking. Electric appliances have cost and training implications.</p>	<ul style="list-style-type: none"> • <u>Short-term</u>: Gather feedback to better understand impacts to cultural cooking and cost impacts to new restaurants. • <u>Long-term</u>: Partner with training providers to build familiarity with and gather feedback on cultural cooking on electric appliances.



<p>5) Funding</p>	<p>Resources are needed to further advance racial equity in all-electric buildings, and to ensure a just transition for workers.</p>	<p><u>Long-term</u>: Create a funding stream using the climate justice principle where the largest polluter pays for the transition, such as a fee for large existing commercial buildings.</p>
------------------------------	--	---

#1: Energy Cost Burdens for Tenants

The policy brief for the proposed ordinance³ references studies on certain building types—single family homes, low- and medium-rise residential, office, retail—that indicate a financial benefit over the lifetime (30 years) of the all-electric building. This projected financial benefit is applicable to building owners. However, not all tenants pay for building-wide operational costs and most will likely not live in the building for the duration of its lifetime. While early adopters of all-electric building with solar PV expect lower utility bills than for a typical multifamily building,⁴ there is no research about utility costs for tenants and variability by building type. Tenants are subject to volatility in energy markets, and spikes may be felt more acutely in single fuel systems. The retail price of gas for California residents has historically been more volatile over time than electricity. California's gas utilities, including PG&E, have proposed and/or received approval to increase gas rates faster than electric rates 2019-2025.⁵ Higher utility bills disproportionately burden lower income tenants.

Recommendations to Advance Racial Equity

- Short-term: SFE could conduct post-occupancy evaluation of monthly costs to investigate potential burdens, monitor utility cost, and compile best practices for reducing utility costs for tenants in general.
- Long-term: SFE could work with utility regulators and providers to facilitate equitable and affordable rate structures, and work with tenant organizations to develop educational materials about peak electricity pricing and opportunities to reduce energy costs. SFE, in partnership with stakeholders like the SFPUC and PG&E, which are more directly involved in these areas, should monitor policy opportunities that provide subsidies, incentives, and/or other financial assistance that could be expanded for energy efficiency, solar, and/or other technologies to ensure affordability for lower income tenants.

#2: Affordable Housing

The policy brief for the proposed ordinance⁶ indicates that low- and medium-rise residential, among other building types, will benefit from lower construction cost through the elimination of natural gas infrastructure and lifetime savings that include both cost reductions in building operations and societal cost from building all-electric construction. The ordinance development process engaged over 40 different affordable housing professionals, along with the Mayor’s Office of Housing and Community Development (MOHCD), and it was generally agreed that electric buildings are affordable and reliable and provide good solutions for both tenants and developers. There was not an expressed need for special exceptions for affordable housing, including a financial exemption. Early adopters of all-electric building have found it to be cost neutral at a minimum in multifamily affordable housing.⁷ While all-electric affordable housing developments are currently being built in San Francisco at a lower cost than equivalent mixed-fuel buildings, it’s

³ https://sfenvironment.org/sites/default/files/fliers/files/sfe_zebtbf_new_construction_policy_brief.pdf

⁴ <https://developingresilience.uli.org/case/maceo-may/>

⁵ https://www.ethree.com/wp-content/uploads/2019/04/E3_Residential_Building_Electrification_in_California_April_2019.pdf

⁶ https://sfenvironment.org/sites/default/files/fliers/files/sfe_zebtbf_new_construction_policy_brief.pdf

⁷ <https://developingresilience.uli.org/case/maceo-may/>

important to note that examples of all-electric buildings in San Francisco are limited and some developers may lack expertise in all-electric building design.

A variety of circumstances and factors affect San Francisco's ability to produce a sufficient supply of affordable housing. Construction costs are one such factor: in 2019 San Francisco was found to have the highest construction costs in the world.⁸ Construction costs themselves are affected by a variety of factors, including increased project costs due to additional required design work,⁹ and a "lack of competition from subcontractors, especially in specialized trades (electrical, plumbing, etc.), is driving up bids for new development projects."¹⁰ While these factors are independent of a fuel switch requirement, it is important that fuel switching does not contribute to the affordable housing shortage in any way. Any impediments to producing affordable housing will burden all of San Francisco, and in particular people who are unhoused, housing cost burdened, and/or at risk of displacement—all three of which are experienced disproportionately by Black populations and People of Color.¹¹ Thus far, the evidence is showing that all-electric affordable housing developments are lowering construction costs for affordable units, and as such, might lower costs for the affordable housing construction industry in San Francisco.

Recommendations to Advance Racial Equity

- **Short-term:** SFE, along with departments responsible for affordable housing production, should focus outreach and technical assistance to affordable housing developers who are unfamiliar and/or inexperienced with all-electric construction. SFE racial equity staff can compile a list of potential stakeholders to provide assistance for this effort. SFE will develop a fact sheet to connect affordable housing developers to resources, such as incentives available through the Building Initiative for Low Emissions Development (BUILD) program.
- **Long-term:** SFE in conjunction with relevant city agencies and partners could continue to facilitate feedback mechanisms (e.g., a survey or listening session) to hear from affordable housing developers about obstacles, lessons learned, and changes in construction and operational costs in all-electric buildings. It may be prudent for the feedback gathering process to include broader building requirements, not only the all-electric new construction requirement. This process could also be an opportunity for an exchange of best practices.

#3: Workforce Considerations

A statewide analysis of the employment impacts of building electrification for new construction calculated a small decrease in jobs statewide. This study assumes that all-electric new residential construction is less expensive than gas-dependent construction due, in part, to avoiding the cost of natural gas piping associated with the service and meter connection. These avoided costs translate to reduced labor requirements. In the commercial and mixed-use sector, the cost difference between mixed-fuel and all-electric buildings is so minor that the study does not project a net change in employment for commercial new construction.¹² On a local level, no net impact on new construction jobs is expected. New buildings need hot water, heating, cooling, cooking, and clothes drying regardless of the energy source used (i.e., construction activity to install new plumbing, ductwork, and appliances). This was confirmed by labor representatives during the stakeholder engagement process. Electricians, green building professionals, and others involved in all-electric

⁸ International Construction Market Survey (2019). Turner and Townsend

⁹ https://sfenvironment.org/sites/default/files/fliers/files/sfe_zebtbf_new_construction_workgroup_notes_1.pdf

¹⁰ p. 27 https://default.sfplanning.org/publications_reports/Housing_Affordability_Strategies_Report.pdf

¹¹ https://default.sfplanning.org/publications_reports/Housing-Needs-and-Trends-Report-2018.pdf;

<https://sfgov.legistar.com/View.ashx?M=F&ID=7586870&GUID=9E0222B9-7A4D-4082-8CCE-3F397520FC82>

¹² https://innovation.luskin.ucla.edu/wp-content/uploads/2019/11/California_Building_Decarbonization.pdf



building design and construction could benefit from this proposed ordinance if work opportunities increase. Since all-electric buildings are new, there is a potential learning curve for workers. Stakeholders expressed the importance of companion workforce training and development to the ordinance.¹³

Historically, the green building industry and building trades lack diversity and are disproportionately white. The demand for skilled electrification professionals could continue to benefit the white population and leave out BIPOC. In 2018, American Indian and Black San Franciscans were more than three times more likely to be unemployed than Whites and unemployment rates were similarly high for Native Hawaiian / Pacific Islanders and Latinxs. Job inequality in San Francisco contributes to income and wealth inequality by race. Additionally, fossil fuel jobs have provided workers better pay, benefits, and longevity than green jobs.¹⁴ To ensure a just and equitable transition into the new green economy, structures need to be put in place to foster workforce opportunities for BIPOC.

Recommendations to Advance Racial Equity

- **Short-term:** SFE should focus outreach and technical assistance on BIPOC-owned businesses and racial/ethnic affinity professional organizations. SFE racial equity staff can identify stakeholders to assist in this process.
- **Long-term:** Economic and workforce development interventions are needed to complement this ordinance, and to ensure racial equity in the just transition away from an extractive economy. Potential future workforce activities that SFE could play a supportive role include:
 - Developing training for all-electric building construction and maintenance that is targeted to Black, Indigenous, and People of Color (BIPOC) and people with barriers to employment.
 - Developing incentives, requirements, and/or certification standards for contractors who hire graduates of the training.
 - Developing incentives, requirements, and/or other opportunities to direct work to BIPOC-owned businesses.

#4: Restaurants

Cooking on an open gas flame may be more important to the cuisine of certain cultures,¹⁵ and there may not be an electric substitute that can perform as effectively. Electric appliances, while more efficient to operate, are more expensive and, at this point in time are a new technology that cannot be purchased second-hand and at a discount.¹⁶ Since this does not impact any existing restaurants, the focus on the recommendations are to help future restaurants adapt to this new requirement.

Recommendations to Advance Racial Equity

- **Short-term:** SFE should gather feedback to better understand impacts to cultural cooking. SFE should search for chefs who are leading the way on cultural cooking with electric appliances, such as through engaging restaurant incubators, trade schools, and industry associations. SFE racial equity staff can support the identification of potential restaurants for engagement. SFE can also gather feedback about the cost impacts to new restaurants. The longer implementation time period for restaurant compliance can provide an opportunity to extend outreach to more diverse stakeholders seeking to open restaurants in newly constructed buildings.

¹³ https://sfenvironment.org/sites/default/files/fliers/files/sfe_zebtbf_new_construction_workgroup_notes_3.pdf

¹⁴ https://greenlining.org/wp-content/uploads/2019/10/Greenlining_EquitableElectrification_Report_2019_WEB.pdf

¹⁵ https://sfenvironment.org/sites/default/files/fliers/files/sfe_zebtbf_residential_meeting_notes_3.pdf

¹⁶ https://sfenvironment.org/sites/default/files/fliers/files/sfe_zebtbf_new_construction_workgroup_notes_1.pdf



- Long-term: Provide appliances to and training through restaurant incubators, trade schools, and industry associations on cultural cooking on electric appliances to build familiarity with technology and provide feedback to SFE.

#5: Funding

Resources are needed to further advance racial equity in the construction of new all-electric buildings, and to ensure a just transition away from an extractive economy.

Recommendations to Advance Racial Equity

- Long-term: SFE could research the creation of a new funding stream using the climate justice principle in which the largest polluter pays for the transition, such as a fee for large existing commercial buildings. This principle could be applied beyond buildings to other sectors with high GHG emissions and to workforce programs beyond building electrification.



Proposed Ordinance: All-Electric Buildings for New Construction

Prepared by the San Francisco Department of Environment - June 30, 2020

Overview

In order to reduce health and safety risks endemic to natural gas and to help prevent irreversible damage from climate change, policymakers are proposing an ordinance that would prohibit the use of natural gas in newly constructed buildings in San Francisco. Natural gas, which is typically used to provide water and space heating, and for cooking and other uses, would be eliminated, in favor of all-electric new construction. This ordinance would apply to construction of all new buildings, both residential and non-residential, that apply for initial building permits after January 1, 2021. It does not impact existing buildings, additions, or alterations. The ordinance would allow for limited exceptions on a case-by-case basis when particular all-electric building systems are determined to be not feasible using currently available technology.

Rationale

The ordinance is designed to address the risks to health, safety, resilience, and equity posed by natural gas infrastructure, indoor combustion of natural gas, and climate change to San Francisco.

Health: Exposure to the pollutants produced from natural gas appliances can be detrimental to human health. Buildings that are constructed as all-electric eliminate both indoor and outdoor air pollution from burning natural gas. The combustion of natural gas emits a wide range of air pollutants, such as carbon monoxide (CO), nitrogen oxide (NOx), and particulate matter (PM) which have been linked to various acute and chronic health effects including asthma in children, respiratory illness, cardiovascular disease, and premature death.ⁱ

Safety: Reducing the reliance on the natural gas system improves resilience by reducing the fire risk and simplifying building systems and maintenance. Natural gas plumbing in buildings poses fire, explosion, and public safety risks. On average in the United States, a natural gas or oil pipeline catches fire every four days, results in an injury every five days, explodes every 11 days, and leads to a fatality every 26 days.ⁱⁱ For example, on February 6, 2019, a natural gas line explosion on Geary Street burned five buildings.ⁱⁱⁱ In 2010, the explosion of a natural gas pipeline in San Bruno resulted in eight fatalities and destroyed an entire neighborhood.^{iv}

Resilience: Natural Gas line ruptures caused half of the fires in San Francisco after the 1989 Loma Prieta earthquake, and even today, it is estimated that after a 7.9 earthquake it would take six months to restore natural gas services citywide, while electricity could be restored in less than a week.^v

Equity: For low-income communities and communities of color that spend a disproportionate amount of their income on energy, and who are more likely to suffer from asthma due to poor indoor air quality, zero emission homes are an important opportunity to deliver social equity benefits.

Climate Change: San Francisco has set greenhouse gas emissions reduction targets of 68% by 2030 and zero net emissions by 2050.^{vi} In conjunction with those goals, Mayor London Breed has committed to ensure new buildings in San Francisco will generate no operational emissions by no later than 2030. In 2018, the residential buildings sector, which accounted for 22% of the city's carbon footprint, had 88% of its emissions arise from the use of natural gas. At the same time, the commercial buildings sector, which accounted for an additional 22% of the city's carbon footprint, had 76% of its emissions arise from the use of natural gas.^{vii} Natural gas is a non-renewable combustible



fuel that is mostly comprised of methane, a greenhouse gas that is 86 times more potent than carbon dioxide.^{viii} The elimination of natural gas is a necessary component to achieve the City’s climate goals.^{ix}

Authority and Requirements

The authority for this ordinance will be established in San Francisco Building Code Section 106A.1.17. This ordinance requires the construction of all new buildings to be all-electric. Natural gas plumbing systems shall not be installed within any new building to serve any system or device for heating, cooling, water heating, cooking, or clothes drying. Furthermore, no permits that would alter, modify, or otherwise convert all-electric buildings into mixed-fuel buildings will be issued. Building Code Section 106A.1.17.1 is not an energy requirement; it is a provision enacted for protection of health and safety.

Applicability

The requirements of section 106A.1.17 of the San Francisco Building code shall apply to all applications for building permits for new construction in San Francisco submitted to San Francisco Department of Building Inspection (DBI) starting January 1, 2021. For projects that include areas specifically designated for occupancy by a commercial food service establishment, building permits may continue to be accepted until January 1, 2022 that provide gas plumbing exclusively for cooking equipment only.

Exceptions

The legislation allows for the DBI Director to modify requirements for an all-electric building in limited circumstances. Requirements can only be modified on a case by case basis, solely in the event a project sponsor demonstrates it is infeasible to build all-electric. The exception process requires a qualified professional to provide a third-party verification to confirm all-electric construction is infeasible for a specific area or system, and confirm the project is wired for future electrification. Any exception must be limited to the specific system or area of the project deemed to be infeasible using current available technology. When a new building receives an exception, the building is termed a “Mixed-Fuel Building”. Mixed Fuel Buildings are subject to additional energy efficiency requirements,^x electric-ready provisions, and required to provide equivalent protections in the design of the project for health and safety.

Impact

The San Francisco housing pipeline consists of development projects that would add residential units or commercial space. The housing pipeline includes only applications which have been formally submitted to the Planning Department or DBI. This new ordinance would only apply to projects that have not formally submitted building permit applications to DBI, including applications for site permits prior to January 1, 2021. Based on the housing pipeline data from 2019 Q2 (Table 1) – the new ordinance would apply to approximately 65% of the housing units in the pipeline and 75% of the commercial space.^{xi}

Table 1. Estimated Applicability of All Electric New Construction Requirement (Based on 2019 Q2 Pipeline Report)

Status of application	Would new ordinance apply?	Housing Units	Affordable Units	Square Footage of Commercial
Application Filed and Approve by Planning Department	Yes	54,203	10,868	31,942,514



Building Permit Application Filed with Department of Building Inspection	No	8,543	1,370	762,477
Lapsed Building Permit Application is "re-instated" by Department of Building Inspection	No	101	8	8,021
Building Permit Application Approved by Department of Building Inspection	No	1,886	75	97,849
Approved Building Permit Application Issued by Department of Building Inspection	No	7,477	1,540	2,633,351
Project is Under Construction	No	10,325	2,863	6,619,567
	Total	82,535	16,724	42,063,779

Cost Impacts

In many scenarios, notably most new home construction, electrification of space and water heating reduces the homeowner’s costs over the lifetime of the building, when compared with fossil fuel use. Three statewide cost-effectiveness studies were completed examining all-electric requirements for the 2019/2020 Building Energy Efficiency Standards.^{xii} While the studies provided a comprehensive analysis of building prototypes representative of new construction, some supplementary analysis was required by the San Francisco Department of Environment around existing PV requirements. The results are summarized in Table 2 below.

Table 1. Incremental costs and benefits normalized by building floor area (e.g., cost per square foot) for all-electric

Use	All Electric	
	Change in Construction Cost (\$/Sq Ft)	Lifetime Savings (\$/Sq Ft)
Single family	-\$5.01	\$3.62
Multifamily 3 floors or less	-\$1.18	\$4.64
Multifamily 4 - 8 floors	-\$0.13	\$0.68
Retail	-\$0.98	\$6.37
Office	-\$1.54	\$1.09

Negative numbers for the construction cost indicate a construction cost below baseline (prescriptively compliant mixed fuel). Positive values for lifetime savings indicate a financial benefit.



SF Environment

Our home. Our city. Our planet.

A Department of the City and County of San Francisco

Sources

i See for example:

UCLA Fielding School of Public Health (2020) Effects of Residential Gas Appliances on Indoor and Outdoor Air Quality and Public Health in California. coeh.ph.ucla.edu/effects-residential-gas-appliances-indoor-and-outdoor-air-quality-and-public-health-california

Lin, Brunekreef, Gehring (2013) Meta-analysis of the effects of indoor nitrogen dioxide and gas cooking on asthma and wheeze in children. academic.oup.com/ije/article/42/6/1724/737113, and

Nicole (2014) Cooking Up Indoor Air Pollution ehp.niehs.nih.gov/doi/pdf/10.1289/ehp.122-A27

ii Kelso (2018) “Pipeline Incidents Continue to Impact Residents” www.fractracker.org/2018/12/pipeline-incidents-impact-residents/

iii ABC 7 News (2019) NTSB releases preliminary report on gas line explosion in San Francisco. abc7news.com/ntsb-releases-preliminary-report-on-gas-line-explosion-in-san-francisco/5160531/

iv Wikipedia (2019) en.wikipedia.org/wiki/San_Bruno_pipeline_explosion

v San Francisco Lifelines Council (2014) “Lifelines Interdependency Study” sfgov.org/orr/sites/default/files/documents/Lifelines%20Council%20Interdependency%20Study.pdf

vi San Francisco Environment Code Chapter 9 (2008) <http://bit.ly/SFGHGLIMITS>

vii San Francisco Climate Dashboard (2020) sfenvironment.org/sf-climate-dashboard

viii San Francisco Department of Environment (2017) Methane Math: How cities can rethink emissions from natural gas” sfenvironment.org/sites/default/files/fliers/files/methane-math_natural-gas-report_final.pdf

ix San Francisco Department of Environment (2019) Focus 2030: A Pathway to Net Zero Emissions. sfenvironment.org/sites/default/files/fliers/files/sfe_focus_2030_report_july2019.pdf

x San Francisco Board of Supervisors File 190974 (2020) sfgov.legistar.com/LegislationDetail.aspx?ID=4148399&GUID=9BB45FCD-B034-41A1-9C8F-5E7BA14B278A

xi San Francisco Planning Department (2019) Pipeline Report. sfplanning.org/project/pipeline-report

xii See:

2019 Residential New Construction Cost-effective Study (released 8-1-2019)
localenergycodes.com/download/800/file_path/fieldList/2019%20Res%20NC%20Reach%20Codes and

2019 Nonresidential New Construction Cost-effective Study (released 8-1-2019)
localenergycodes.com/download/801/file_path/fieldList/2019%20NR%20NC%20Cost%20Effectiveness%20Study-2019-07-25.pdf and

2020 Residential Mid-Rise New Construction Cost-effective Study (not yet released)



ADMINISTRATIVE BULLETIN

NUMBER AB-112

DATE: Effective January 1, 2021

SUBJECT: Administration and General Design

TITLE: Implementation of All Electric New Construction Regulations

PURPOSE: The purpose of this Administrative Bulletin is to detail standards and procedures for the implementation of the all-electric new construction requirements of the San Francisco Building Code effective January 1, 2021.

REFERENCE: 2019 San Francisco Building Code; 2019 San Francisco Green Building Code; San Francisco Administrative Bulletin 005: Procedures for Approval of Local Equivalencies; 2019 California Building Standards Code; San Francisco Environment Code, Chapter 7.

- 1) DISCUSSION
- 2) CRITERIA FOR EXCEPTION ALLOWING A MIXED-FUEL BUILDING SYSTEM OR AREA
- 3) THIRD-PARTY REVIEW FOR DETERMINATION OF INFEASIBILITY
 - a) REVIEWER QUALIFICATIONS
 - b) REVIEWER SUBMITTALS FOR MIXED-FUEL BUILDING SYSTEM OR AREA
- 4) SUBMITTALS REQUESTING EXCEPTION ALLOWING A MIXED-FUEL BUILDING SYSTEM OR AREA

Attachment 1: Design Guideline for Electric Ready Buildings

Attachment 2: Summary of Investor Owned Utility Options for Proposed Electric Load Exceeding Capacity of Utility Infrastructure

1) DISCUSSION

Approved construction documents and completed projects must conform to requirements established in the San Francisco Building Code. San Francisco Building Code 106A.1.17.1 requires applications for permit submitted after January 1, 2021 to construct new buildings to be designed and constructed such that all space-conditioning, water heating, cooking, and clothes drying systems are all-electric, as defined, and prohibits installation of infrastructure, piping systems, or piping for distribution of natural gas or propane to such uses.

APPLICABILITY

San Francisco Building Code Section 106A.1.17.1 applies to all permit applications for new construction submitted on or after January 1, 2021 proposing to construct one or more new buildings in San Francisco

In the case of Site Permits, the effective date is the date the Site Permit application (not an addendum) is filed with the Department of Building Inspection. Addenda to site permits and revisions to permit applications received on or after January 1, 2021 are not required to meet the requirements of San Francisco Building Code Section 106A.1.17.1, unless the addenda or revisions change the scope of the project such that current codes are generally applicable, or such that an exception granted on the basis of infeasibility is no longer warranted.

For projects which submit an initial application for permit after January 1, 2021 and before January 1, 2022, areas specifically designated for commercial food service may provide gas piping systems, fixtures, and infrastructure exclusively for cooking equipment within the area designated for commercial food service. However, such projects are by definition "mixed-fuel" and subject to applicable requirements (see Administrative Bulletin 93).

DEMONSTRATION OF COMPLIANCE

San Francisco Building Code Section 106A.1.17.1 is not an energy requirement; it is a provision enacted for protection of health and safety. For administrative efficiency, no special documentation is necessary for projects that comply with San Francisco Building Code Section 106A.1.17.1. Projects that do not seek an exception are to document compliance via normal documentation requirements and procedures, such as:

Piping Systems and Mechanical Systems

Project submittals providing any construction detail related to gas piping systems or mechanical system design must be consistent with all-electric design and construction, and not indicate the installation of gas piping systems, fixtures, or infrastructure. Documentation of compliance with California Title 24 Part 6 Energy Standards shall not include any indication of gas consumption for space conditioning, water heating, cooking, or clothes drying.

San Francisco Green Building Standards

Administrative Bulletin 93 (Implementation of Green Building Regulations) provides guidance for determining which provisions of relevant local ordinances and state building codes apply to a project, describes implementation procedures, and provides forms to document compliance. Per Administrative Bulletin 93, compliance with San Francisco Building Code Section 106A.1.17.1 (or Environment Code Section 706(d)(7) in the case of municipal buildings), shall be documented as required by Administrative Bulletin 93:

- Permit applications for new construction are not accepted without Green Building Site Permit Submittal GS-1.
- The submittal package for each addendum that includes architectural details must include a Green Building Submittal checklist incorporated into the project plans indicating the required measures and referencing location of such features in the construction documents and providing compliance details for each requirement. For newly constructed buildings, either GS-2, GS-3, or GS-6 is required with each addendum.

USES NOT SPECIFICALLY REGULATED

An All-Electric Building or Project as defined by San Francisco Building Code Section 202 is a building or project that relies on electricity as the source of energy for all space heating, space cooling, water heating, cooking, and clothes drying. Gas piping systems, fixtures, or infrastructure may be installed strictly to serve areas and systems outside the scope of this definition, such as industrial processes.

In projects that include uses not specifically addressed by this definition, all space heating, space cooling, water heating, cooking, and clothes drying systems must be designed and constructed as all-electric, and such a project is defined as "all-electric" for the purpose of compliance with San Francisco Green Building Code 4.201.1 and 5.201.1.2.

EXCEPTIONS

Compliance with San Francisco Building Code Section 106A.1.17.1 and all other requirements for new construction have been determined to be practical and feasible. An exception may be made only when an all-electric project is demonstrated to be physically or technically infeasible, and an exception shall only apply to the extent necessary to resolve the demonstrated infeasibility. The remainder of this bulletin describes the process for determination of infeasibility and grant of an exception allowing installation of natural gas piping systems, fixtures, or infrastructure.

2) CRITERIA FOR EXCEPTION ALLOWING A MIXED-FUEL SYSTEM OR AREA

San Francisco Building Code Section 106A.1.17.1 allows for approval of exception allowing gas infrastructure and piping systems to be installed on a case-by-case basis where All-Electric construction is demonstrated to be physically or technically infeasible. Physical or technical infeasibility is understood to refer to an exceptional situation where:

- A project proposal cannot be accomplished due to physical or technical constraints specific to site and occupancy that prohibit elements, spaces or features necessary for full and strict compliance with all requirements for new construction;

AND

- If a specific system or area is served by gas piping systems, fixtures, and infrastructure, then the physical or technical infeasibility is resolved, and the project is able to attain full and strict compliance with all requirements for new construction.

To qualify for such an exception, the project must:

1. Undergo a Third Party Review of All-Electric Feasibility, resulting in a determination by the reviewers that there is no means by which a proposed function or service may be provided by an all-electric design compliant with all applicable codes; and that the proposed function or service can feasibly be provided if gas piping systems, fixtures, and infrastructure are installed.
2. Limit installation of natural gas piping systems, fixtures, and infrastructure to the system or area for which All-Electric design is infeasible;
3. Ensure the area and system served by natural gas piping systems provides for future conversion to All-Electric, by complying with the applicable provisions of Electric Ready Design Guidelines (Attachment 2) to the maximum extent feasible.
4. Demonstrate that the project's modified design provides equivalent fire-protection and health and safety to All-Electric design.

Financial considerations are not a basis for determination of physical or technical infeasibility.

Criteria for determination of infeasibility:

Category	Criteria
<p>A) Energy Standards</p>	<p>Compliance with Title 24 Part 6 Energy Standards for all-electric design may be infeasible only if there is no prescriptive option for compliance with the Energy Standards, nor an option for compliance under the performance method for any system or technology serving the specific use.</p> <p>Proposal to install a technology, system, or design not allowed under the Energy Standards does not demonstrate infeasibility where all-electric technologies, systems, or designs are available for compliance with the Energy Standards.</p>
<p>B) Electric Utility Infrastructure</p>	<p>All-electric design may be infeasible if:</p> <ul style="list-style-type: none"> • Electric load calculations are prepared for both mixed-fuel design for a specific system or area, and all-electric design, with equivalent occupancies, functions, and floor area; and • The project submits an application for service to the electric utility serving the project; and • The utility determines that (a) the peak electric demand required for the all-electric design option cannot be served, and (b) the peak electric demand requested for the mixed-fuel design option can be served under substantially similar conditions. Substantially similar conditions shall include equivalent occupancies, functions, and floor area, as well as the same consideration of the time required for the utility to complete modifications to utility infrastructure, where necessary. <p>Under California Public Utilities Commission Rule 2.C, utilities are obligated to provide service. Request by the utility for the customer’s proposal to comply with applicable tariff, easement, safety, and reliability requirements, or for reasonable time to construct improvements, is not a basis for infeasibility.</p>
<p>C) Physical Constraint in Small Infill Sites</p>	<p>All-electric design may be infeasible if:</p> <ul style="list-style-type: none"> • Electric load calculations are prepared for both a design including a specific mixed-fuel system and area, and all-electric design, with equivalent occupancies, functions, and floor area; and • Based on the rules published by the electric utility serving the site: <ul style="list-style-type: none"> ○ Peak electric demand for the mixed-fuel design does not require the installation of an electric service transformer; and ○ Peak electric demand for all-electric design with the same features requires the installation of an electric transformer; and • The site has a linear footage of street frontage of 75 feet or less;¹ and • Joint review by the Planning Department and Public Works Department determines there is no feasible option to locate an electrical transformer in the building or elsewhere on the property, and: <ul style="list-style-type: none"> ○ The only feasible option is to locate the transformer in a sub-surface vault in the public Right of Way; or ○ The sidewalk at the site is less than 10 feet in width, such that a sub-surface vault in the public Right of Way infeasible.
<p>D) Exceptional Circumstance</p>	<p>All-electric design may be infeasible if</p> <ul style="list-style-type: none"> • It is demonstrated physical or technical constraints specific to site and occupancy prohibit elements, spaces or features necessary for full and strict compliance with all requirements for new construction; and • If gas piping systems and fixtures are substituted for electrical equipment serving a specific system or area, the project is able to attain full and strict compliance with all requirements for new construction. <p>Proposal to install a technology, system, or design that is inconsistent with, or not allowed by the discretionary determination by a City agency shall not be a basis for demonstration of infeasibility.</p>

¹ The linear footage of street frontage is calculated by adding the lengths of all property lines directly adjacent to the right of way.

3) THIRD-PARTY REVIEW FOR DETERMINATION OF INFEASIBILITY

Compliance with San Francisco Building Code Section 106A.1.17.1 and all other requirements for new construction have been determined to be practical and feasible in general. San Francisco Building Code Section 106A.1.17.1 allows for approval of exception allowing gas infrastructure and piping systems to be installed on a case-by-case basis where All-Electric construction is demonstrated to be infeasible.

The conditions of infeasibility depend substantially on design details, and design development provides substantial opportunity to address physical and technical conditions. An application for design review for exception due to infeasibility will not be approved in the absence of substantial architectural detail, including the architectural addendum and Title 24 compliance documentation.

Prior to DBI review of an application for exception due to infeasibility, a Third-Party Review of All-Electric Feasibility must be completed by engineers with specialized understanding of electrical engineering, mechanical design, energy efficiency including compliance with Title 24 Energy Standards, and experience with the design of all-electric systems for space conditioning and water heating. In all cases, it is the responsibility of the Design Professional of Record, with the support of the entire project team, to apply all available energy efficiency and electric load minimization practices.

Review of All-Electric Feasibility

Review of All-Electric Feasibility is a document that addresses three questions:

- What specific constraint causes all-electric design to be physically or technically infeasible, but does not apply to mixed-fuel?
- Can the constraint be resolved?
- Is the area and system proposed served by gas piping systems ready for conversion to all-electric in the future, and constructed to provide equivalent health, safety and fire protection?

To address these questions, a Review of All-Electric Feasibility must include:

- **Identify the physical or technical constraint:** Document the specific physical or technical issue that results in the infeasibility of All-Electric design of the project.
- **Identify alternatives:** Based on review of plans, calculations, and supporting documentation, identify methods, equipment, and design features available to resolve the physical or technical issue to mitigate infeasibility.
 - **Efficiency:** Where the issue relates to peak electrical load, energy efficiency construction practices, design options, and compliance credits can commonly contribute to resolving the issue. For the all-electric design, confirm all available compliance credits have been applied. Confirm all available energy efficiency design and construction practices have been applied to all building features contributing to loads regulated by Title 24 Energy Standards. Confirm equipment specified is no less efficient than prescriptive baseline specified by Title 24 Energy Standards.
 - **Mechanical:** Review envelope and architectural features and mechanical design are consistent with minimization of load on mechanical equipment. Determine whether space conditioning and water heating electric peak load can be reduced via piping or plumbing design, equipment sizing, equipment layout, or substitution of equipment type. Mechanical equipment must be no less efficient than electric prescriptive baseline, where such a baseline is provided by Title 24 Energy Standards.²
 - **Electrical:** Review electrical panel schedule and load calculations for the all-electric design. Confirm connected electrical load and demand electric load for the all-electric design are calculated in accord with California Electrical Code, and are consistent with the design for compliance with Title 24 Energy Standards.
 - Provide documentation of examples of all-electric design and construction of similar systems and circumstances.

² Mechanical equipment is not required to be more efficient than US DOE Appliance and Equipment Standards applicable to the specified device, provided all options are exhausted regarding piping or plumbing design, equipment sizing and layout, and substitution of alternative equipment types.

- **Document Available Solutions:** Review the mixed-fuel design, and document the specific area and system proposed as mixed-fuel. Confirm that the physical or technical constraint will specifically be resolved by granting an exception allowing mixed-fuel construction of the area and system. Confirm proposed gas piping systems, fixtures, and infrastructure are limited to the system or area of the building for which All-Electric design is infeasible.
- **Apply Electric Ready Design Guidelines:** Areas served by gas piping systems, fixtures, and infrastructure must prepare for future retrofit to all-electric by installing sufficient electrical conductors and raceways, bus bar capacity, and overcurrent protection, and providing sufficient space and drainage for future replacement of gas systems with electric. Reviewers shall affirm that the project design conforms to the relevant provisions of Electric Ready Design Guidelines to the extent feasible.
- **Recommendation Regarding Health, Safety, and Fire Protection:** Review construction methods, safety equipment, and design features proposed. Recommend specific design features, equipment, and construction practices sufficient to ensure the project's modified design provides equivalent fire-protection and health and safety to all-electric design.
- Documentation of the above via a report addressing each item above in detail.

Review documentation must be incorporated into plans, with signature by a reviewer for each discipline (electrical, mechanical, and architectural/Title 24), and stamp by the Design Professional of Record.

QUALIFICATIONS FOR ALL-ELECTRIC THIRD-PARTY REVIEWERS

All-Electric Third-Party Reviewers must apply specialized knowledge and experience in the application of energy efficiency design and construction; compliance of all-electric systems with Title 24 Energy Standards, and experience with the design of all-electric systems for space conditioning and water heating. The review team must include each of the following:

Item	Qualification	Minimum Experience
1	Licensed Professional Engineer with Mechanical Specialty	Design and demonstration of compliance for at least one all-electric project which is: <ul style="list-style-type: none"> • Either multifamily (3 or more housing units), or commercial (minimum of 10,000 square feet floor area); AND • Either <ul style="list-style-type: none"> - Construction of a new building, OR - Alteration where scope included replacement of space conditioning and water heating systems.
2	Licensed Professional Engineer with Electrical Specialty	
3	California Association of Building Energy Consultants – Certified Energy Analyst	Title 24 documentation accepted for compliance for at least one all-electric new construction project of the same or similar occupancy to the project under review.

Each of the above disciplines must be represented by individuals not employed by a company responsible for the design or construction of the project.

Due to the qualifications required, review is expected to be performed by a team, but individuals holding multiple qualifications may serve more than one role.

Process for Physical Constraint in Small Infill Sites: Projects seeking exception on the basis of Physical Constraint in a Small Infill Site (Category C above):

- Persons responsible for the design of the project may be responsible for preparation of the review.
- Reviewer(s) must include a minimum of two disciplines:
 - Licensed Professional Engineer with Electrical Specialty, AND
 - Either Licensed Professional Engineer with Mechanical Specialty, or CABEC Certified Energy Analyst.
- The Review for All-Electric Feasibility must address each of the considerations in the *Review for All-Electric Feasibility* section above.

4) SUBMITTALS REQUESTING EXCEPTION ALLOWING A MIXED-FUEL BUILDING SYSTEM OR AREA

If an exception to San Francisco Building Code Section 106A.1.17.1 is granted due to infeasibility, supplemental documentation is required:

- **Project Submittals:** Installation of gas infrastructure and piping systems is strictly limited to the system and area of the building for which all-electric design is infeasible, or systems not specifically regulated by San Francisco Building Code 106A.1.17.1. Project submittals providing any construction detail related to piping systems or mechanical system design must be consistent with all-electric design and construction for all systems and areas excepting the area and system determined to be infeasible.
- **Energy Standards:** Newly constructed buildings are subject to local energy design requirements stricter than California Title 24 Building Energy Efficiency Standards, including provisions specific to Mixed Fuel buildings. See Administrative Bulletin 93 for details.

PERMISSION TO CONSTRUCT A MIXED-FUEL BUILDING DUE TO INFEASIBILITY

San Francisco Building Code Section 106A.1.17.1 allows the approval of an exception allowing issuance of a permit to construct a new mixed-fuel building only on a case-by-case basis. In order to obtain an exception to San Francisco Building Code Section 106A.1.17.1, the applicant must:

1. Complete a *Special Third-Party Review of All Electric Feasibility*. The third-party review documents the specific area and system proposed to be constructed as mixed-fuel and the basis for a determination all-electric design is infeasible.
2. Submit a *Request for Approval of Local Equivalency for Modification or Alternate Materials, Design, or Methods of Construction* (Administrative Bulletin 005), including two copies of the following documentation of the proposed modification to materials and methods of construction:
 - a. Project plans specifying the area and system proposed for mixed-fuel construction
 - b. *Review of All Electric Feasibility*
 - c. Acknowledgement of energy performance requirements that apply to mixed-fuel design (see Administrative Bulletin 93)
 - d. Affirmation of the specific provisions of Electric Ready Design Guidelines (Attachment 2) that pertain to the area and system of mixed fuel construction. If it is not feasible for the mixed-fuel area or system to fully comply with the guidelines, the project sponsor shall specify the extent to which the guidelines are feasible.
3. Review meetings will be conducted by the Department of Building Inspection, with the Department of Environment and the Fire Department where applicable, to consider the request for approval of *Request for Approval of Local Equivalency for Modification or Alternate Materials, Design, or Methods of Construction* (Administrative Bulletin 005). Attendance at such review meetings will include, at a minimum, the Design Professional of Record, the project mechanical engineer, and the Third Party Reviewers.

At such meetings, it is the responsibility of the project applicant to demonstrate infeasibility. Staff will

- Review plans, calculations, and supporting documentation for all-electric options demonstrate all available energy efficiency features, practices, and credits for third-party review were applied to the all-electric option.
- Review alternative technologies and approaches considered prior to the All Electric Third Party Reviewers making a determination.
- Review the mixed-fuel design, including the specific area and system served by gas piping systems, fixtures, and infrastructure
- Review conditions proposed to ensure the project's modified design provides equivalent fire-protection and health and safety to all-electric design.

The request will either be:

- Approved with conditions by DBI with concurrence by Department of Environment,

- Placed on “hold” pending submittal of additional information, or
- Disapproved.

Determinations as to infeasibility may be appealed to the Board of Examiners, as established under Section 105.1 of the San Francisco Building Code. See <https://sfdbi.org/board-examiners> for details.

The project sponsor is responsible for the hiring of Third Party Reviewers from the list of approved All-Electric Third Party Reviewers maintained by the Department of Building Inspection. The project sponsor is responsible for all costs related to All Electric Third Party Review.

Plan review fees are required to be paid as noted in Administrative Bulletin 005.

4. Upon approval to construct a mixed-fuel building, a copy of the signed form approving the equivalency and indicating all conditions of approval will be part of the permanent record of the project, and a copy will be sent to the project sponsor. The project sponsor shall include all specified conditions in plans.

PROJECT COMPLETION

Final compliance verification documentation (Attachment 3) is required prior to final inspection. No final Certificate of Completion may be issued until All-Electric Ordinance: Final Compliance Verification has been received, reviewed, and accepted by the Department of Building Inspection.

Failure to ensure the project is designed and constructed in a manner consistent with an exception and conditions approved will subject the project to all of the enforcement and abatement remedies detailed in the San Francisco Building Code.

LIST OF ALL-ELECTRIC THIRD-PARTY REVIEWERS

The Department of Building Inspection with the assistance of Department of Environment shall regularly conduct a Request for Qualifications to identify professionals with specialized knowledge and experience in the application of energy efficiency design and construction; compliance of all-electric systems with Title 24 Energy Standards, and experience with the design of all-electric systems for space conditioning and water heating. Department of Building Inspection shall provide upon request a list of individuals who have provided evidence of holding such qualifications. Third-Party Review of All-Electric Feasibility will only be considered when prepared by an individual listed as holding the appropriate qualifications. Submittal of substantially inadequate or incorrect analysis will be grounds for removal from the list of qualified reviewers.

Signed by:

Director
Department of Building Inspection

Attachment 1: Design Guideline for Electric Ready Buildings

San Francisco Building Code Section 106A.1.17, Exception (1) requires Mixed-Fuel Buildings to be as “Electric-Ready” as feasible. Electric Ready is defined as:

***ELECTRIC-READY.** A building, project, or portion thereof that contains electrical systems and designs that provide capacity for a future retrofit of a Mixed-Fuel Building to an All-Electric Building. Electric-Ready includes sufficient space, drainage, electrical conductors or raceways, bus bar capacity, and overcurrent protective devices.*

Design Guideline for Electric Ready Buildings is adapted from California Energy Codes & Standards Program 2019 Model Electric Readiness Code (www.localenergycodes.com), and provided as a reference for how to fulfill the Electric-Ready requirements of San Francisco Building Code Section 106A.1.17, Exception (1).

Since exceptions are limited to the specific areas or systems where All Electric design is physically or technically infeasible, even in Mixed Fuel Buildings nearly all systems will be All-Electric.

These guidelines do not require the design of electric replacement systems and as such do not necessarily assure that the conversion to all-electric will be directly feasible in all cases. Instead, the requirements specify power equivalencies for provision of a given service via all-electric and offer flexibility regarding locations for replacement equipment. These guidelines do not include space and ventilation requirements for engineered systems (e.g., space or water heat systems serving multiple dwelling units or large spaces), and as such, conversion to all-electric will be dependent upon the ability to provide these components. Future upgrades of the utility-side electric power service may require additional space for equipment. For the reasons stated above, permit applicants are encouraged to prepare an initial design for future replacement with electric systems to address future locations for heat absorption, transfer and distribution equipment, as well as electric power systems.

Electric Ready Guidelines for Residential (Type R Occupancy)

General

New residential Mixed-Fuel Buildings that are Electric Ready provide capacity for a future retrofit to facilitate the installation of all-electric equipment for all equipment requiring provision of fuel gas, and future de-commissioning of all gas piping, connections. An Electric Ready design provides space, drainage, installs electrical conductors or raceways, reserves bus bar capacity, and reserves space for overcurrent protective devices for future replacement of all gas-dependent equipment with all-electric equipment. and for equipment serving individual units only, service panel capacity and pre-wired and installed overcurrent protective devices.

Space Heat

Systems using natural gas heating equipment shall include the following components for each gas terminal or stub out:

Equipment serving individual dwelling units:

1. A dedicated 240 volt, 30 amp or greater electrical circuit for a future electric replacement heater;
2. The circuit shall terminate within 3 feet from the designated future location of an electric replacement heater with no obstructions into a listed cabinet, box or enclosure labelled “For Future Electric Space Heater”;
3. The circuit shall be served by a dedicated double pole circuit breaker in the electrical panel labeled with the words “For Future Electric Space Heater”; and

EXCEPTION. If a 240 volt 30 amp or greater electrical circuit exists for space cooling equipment, an additional circuit for space heating is not necessary.

Equipment serving multiple dwelling units or common areas

1. Equipment serving multiple dwelling units or common areas shall have conductors or raceway installed with termination points at the main electrical panel (via subpanels panels, if applicable) and at a location no more than 3 feet from each gas outlet or a designated location of future electric replacement equipment. The conductors or raceway and any intervening subpanels shall be sized to meet the future electric power requirements as specified below and in the "Conductor, Raceway and Subpanel Sizing" Section below.

A. 24 amps at 240 volts per dwelling unit, or

B. The electrical power required to provide equivalent functionality of the gas powered equipment as calculated and documented by a licensed design professional associated with the project.

EXCEPTION: If permanent space cooling equipment is installed for all of the affected dwelling units, the raceway and/or conductors serving the cooling equipment may be sized to accommodate the future electric space heating equipment.

Water Heat

Systems using natural gas or propane water heating equipment shall include the following components for each gas terminal or stub out:

Equipment serving individual dwelling units

Equipment serving individual dwelling units shall be located in an area that is at least 3 feet by 3 feet by 7 feet high.

Equipment serving multiple dwelling units or common areas

Install conductors or raceway with termination points at the main electrical panel (via subpanels panels, if applicable) and into a listed cabinet, box or enclosure at a location no more than 3 feet from each gas outlet or a designated location of a future electric replacement water heater labelled "For future water heater". The conductors or raceway and any intervening subpanels shall be sized to meet the future electric power requirements as specified below and in the "Conductor, Raceway and Subpanel Sizing" Section below.

1. 24 amps at 240 volts per dwelling unit, or

2. 1.2 kVA for each 10,000 Btus per hour of rated gas input or gas pipe capacity, or

3. The electrical power required to provide equivalent functionality of the gas powered equipment as calculated and documented by a licensed design professional associated with the project.

Clothes Drying

Buildings plumbed for natural gas or propane equipment shall include the following components for each gas terminal or stub out:

Equipment serving individual dwelling units

1. A dedicated 240 volt, 30 amp or greater electrical receptacle within 3 feet of the equipment and accessible with no obstructions;
2. The receptacle shall be labeled with the words "For Future Electric Clothes Dryer"; and
3. A double pole circuit breaker in the electrical panel labeled with the words "For Future Electric Clothes Dryer".

Equipment serving multiple dwelling units or common areas

Equipment serving multiple dwelling units or common areas shall include conductors or raceway installed with termination points at the main electrical panel (via subpanels panels, if applicable) and at a location no more than 3 feet from each gas outlet or a designated location of future electric replacement equipment. The conductors or raceway and any intervening subpanels shall be sized to meet the future electric power requirements as specified below and in the "Conductor, Raceway and Subpanel Sizing" Section below.

1. 24 amps at 240 volts per dwelling unit, or
2. 0.85 kVA for each 10,000 Btus per hour of rated gas input or gas pipe capacity, or
3. The electrical power required to provide equivalent functionality of the gas powered equipment as calculated and documented by a licensed design professional associated with the project.

Combined Cooktop and Oven or Stand Alone Cooktop

Buildings plumbed for natural gas or propane equipment shall include the following components for each gas terminal or stub out:

1. A dedicated 240 volt, 40 amp or greater circuit and 50 amp or greater electrical receptacle located within 3 feet of the equipment and accessible with no obstructions;
2. The electrical receptacle shall be labeled with the words "For Future Electric Range" and be electrically isolated; and
3. A double pole circuit breaker in the electrical panel labeled with the words "For Future Electric Range".

Stand Alone Cooking Oven

Buildings plumbed for natural gas or propane equipment shall include the following components for each gas terminal or stub out:

1. A dedicated 240 volt, 20 amp or greater receptacle within 3 feet of the appliance and accessible with no obstructions;
2. The electrical receptacle shall be labeled with the words "For Future Electric Oven" and be electrically isolated; and
3. A double pole circuit breaker in the electrical panel labeled with the words "For Future Electric Oven".

Pools and Spas

Natural gas or propane equipment pools or spas shall have conductors or raceway installed with termination points at the main electrical panel (via subpanels panels, if applicable) and at a location no more than 3 feet from each gas outlet or a designated location of future electric replacement equipment.

The conductors or raceway and any intervening subpanels shall be sized to meet the future electric power requirements as specified below and in the "Conductor, Raceway and Subpanel Sizing" Section below.

1. 0.75 kVA per 10,000 Btus per hour of rated gas input or gas pipe capacity, or
2. The electrical power required to provide equivalent functionality of the gas powered equipment as calculated and documented by a licensed design professional associated with the project.

Service Capacity

Electric load calculations must reflect all loads for systems as installed at the time of new construction, and reflect expected future loads or increases to load as a result of compliance with Electric Ready Design Guidelines.

1. All newly installed electrical panels and subpanels serving common loads in a Mixed-Fuel Building shall have both space for overcurrent protective devices as well as bus bars of adequate capacity to meet all of the building's potential future electrical requirements as specified in the sections above. The engineer of record shall document future expected total electrical load for the building when modified to All-Electric, in order to affirm adequate capacity of the electrical equipment.

Exception: If the electric load serving entity requires that the electric service be upgraded as a result of the requirements of these guidelines, then adequate physical space must be designated for future installation of panels, switchgear, and bus bars sufficient to meet the building's future electrical requirements as specified in these guidelines. Upgrade to electric service is not required.

2. All newly installed raceways in a Mixed-Fuel Building between the main electric panel and any subpanels, and the point at which the conductors serving the building connect to the common conductors of the utility distribution system, shall be sized for conductors adequate to serve all of the building's potential future electrical requirements as specified in these guidelines.

3. The service capacity requirements of this section shall be determined in accordance with the "Conductor, Raceway and Subpanel Sizing" Section below.

Conductor, Raceway and Subpanel Sizing

1. Raceway and subpanel capacity shall be sized to be large enough to meet the requirements at the service voltage.
2. The electrical capacity requirements may be adjusted for demand factors in accordance with the California Electric Code, Title 24, Part 3, Article 220.
3. For purposes of gas pipe equivalence, gas pipe capacity shall be determined in accordance with the California Plumbing Code, Title 24, Part 5, Section 1208.4.

Condensate Drains

The conductors or raceway required in space heating and domestic hot water shall terminate in areas that have condensate drains that are:

1. No less than $\frac{3}{4}$ inch in diameter;
2. Compliant with the California Plumbing Code, Title 24, Part 5, Section 814; and
3. No more than two inches higher than the floor.

EXCEPTION to Sections 4.508.1 through 4.508.10. If the design includes bus bar capacity, raceway or conductor capacity, space and condensate drainage necessary for the installation of electrical equipment that can serve the intended function of the gas equipment, as calculated and documented by a licensed design professional associated with the project.

Electric Ready Guidelines for Non-Residential (All Occupancies other than R)

General

New nonresidential Mixed-Fuel Buildings shall have electrical systems and designs that provide capacity for a future retrofit to facilitate the installation of all-electric equipment for all gas equipment plumbing connections. This includes space, drainage, electrical conductors or raceways, bus bar capacity, and space for overcurrent protective devices.

Circuit Capacity

A Mixed-Fuel Building shall have conductors or raceway installed with termination points at the main electrical panel (via subpanels panels, if applicable) and at a location no more than 3 feet from each gas outlet or a designated location of future electric replacement equipment. The conductors or raceway and any intervening subpanels shall be sized to meet the future electric power requirements, as specified below, at the service voltage. The capacity requirements may be adjusted for demand factors in accordance with the California Electric Code, Title 24, Part 3, Article 220. Gas flow rates shall be determined in accordance with the California Plumbing Code, Title 24, Part 5, Section 1208.4.

Domestic Hot Water

For equipment serving nonresidential space, common areas or multiple dwelling units, 1.2 kVA for each 10,000 Btus per hour of rated gas input or gas pipe capacity or the electrical power required to provide equivalent functionality of the gas powered equipment as calculated and documented by a licensed design professional associated with the project.

Space Heating

For equipment serving nonresidential space, common areas or multiple dwelling units, the electrical power required to provide equivalent functionality of the gas powered equipment as calculated and documented by a licensed design professional associated with the project.

EXCEPTION. If permanent space cooling equipment is installed for all of the affected conditioned space the conductors or raceway serving the cooling equipment may be increased in size to accommodate the future electric space heating equipment.

Clothes Dryer

Provide 0.85 kVA for each 10,000 Btus per hour of rated gas input or gas pipe capacity for commercial dryers, or the electrical power required to provide equivalent functionality of the gas powered equipment as calculated and documented by a licensed design professional associated with the project.

Pools and Spas

Provide either:

- a. 0.75 kVA per 10,000 Btus per hour of rated gas input or gas pipe capacity, or
- b. The electrical power required to provide equivalent functionality of the gas powered equipment as calculated and documented by a licensed design professional associated with the project.

Electric Readiness: Service Capacity

Electric load calculations must reflect all loads for systems as installed at the time of new construction, and reflect expected future loads or increases to load as a result of compliance with Electric Ready Design Guidelines.

All newly installed electrical panels and subpanels in a Mixed-Fuel Building shall have both space for overcurrent protective devices as well as bus bars of adequate capacity in the main electrical panel and any subpanels to meet all of the building's potential future electrical requirements as specified in these guidelines. The engineer of record shall document future expected total electrical load for the building when modified to All-Electric, in order to affirm adequate capacity of the electrical equipment.

Exception: If the electric load serving entity requires that the electric service be upgraded as a result of the requirements of these guidelines, then adequate physical space must be designated for future installation of panels, switchgear, and bus bars sufficient to meet the building's future electrical requirements as specified in these guidelines. Upgrade to electric service is not required.

All newly installed raceways in a Mixed-Fuel Building between the main electric panel and any subpanels, and the point at which the conductors serving the building connect to the common conductors of the utility distribution system, shall be sized for conductors adequate to serve all of the building's potential future electric loads as specified in these guidelines.

Electric Readiness: Condensate Drains

The conductors or raceway required for domestic hot water and space heating systems shall terminate in areas that have condensate drains that are:

- a. No less than $\frac{3}{4}$ inch in diameter;
- b. Compliant with the California Plumbing Code, Title 24, Part 5, Section 814; and
- c. No more than two inches higher than the floor.

Attachment 2: Summary of Investor Owned Utility Options for Proposed Electric Load Exceeding Capacity of Utility Infrastructure

Investor owned utilities such as Pacific Gas and Electric Company are regulated by California Public Utilities Commission under the California Public Utilities Code. Per CPUC-approved Electric Rule 2, a utility may not refuse to extend electric service to customers in PG&E's service territory provided the customer complies with applicable tariff, easement and safety and reliability requirements. In situations where existing infrastructure may not be capable of serving a new load proposed by a customer, PG&E will apply the appropriate tariffs and associated cost responsibilities in order to serve the new load.

If a project proposes peak load and/or generation that exceeds the capacity of existing utility infrastructure serving the location, or if the utility determines the change would push service voltage levels out of ranges specified in CPUC Electric Rule 2.C, there are three possibilities:

- **Modify Design:** The project may be modified to reduce the proposed peak load and/or generation to match existing infrastructure capacity, such as through efficiency, battery storage, or other modifications.
- **Upgrade Utility Equipment Dedicated to the Project:** The project sponsor can upgrade service infrastructure, subject to Electric Rule 16, and utility will provide the level of service supported by the upgraded service infrastructure.
- **Wait for Utility Facility Upgrade:** If the requested peak load and/or generation can only be met after upgrades to distribution or transmission infrastructure are completed by the utility, it may take some time to construct the facilities necessary to serve the new load. The project sponsor may coordinate a construction and service level schedule to accommodate the time needed to construct the facilities as well as a ramp up schedule of the project's load.

Alternative: When a request for service exceeds limitations specified in Electric Rule 2, the Exceptional Case provision of Electric Rule 16.G allows:

“When the application of this rule appears impractical or unjust to either party, or ratepayers, PG&E or Applicant may refer the matter to the Commission for a special ruling or for approval of special conditions which may be mutually agreed upon.”



All-Electric Ordinance: Final Compliance Verification

Attachment 3

This form must be completed prior to issuance of a final Certificate of Completion.

Address: _____

Permit Application Numbers: _____

This project has been designed and constructed to comply with San Francisco Building Code Section 106A.1.17.1.
Check one:

<input type="checkbox"/>	No gas piping systems have been installed.
<input type="checkbox"/>	Gas piping systems have been installed

If gas piping systems have been installed:

<input type="checkbox"/>	The project is Mixed-Fuel, and gas piping systems, fixtures, and infrastructure have been installed, but are limited to the specific system and area approved under AB-112 and AB-005.	
	Indicate System(s):	Indicate Area(s). Include reference to plan sheets.
	_____	_____
<input type="checkbox"/>	Gas piping systems and infrastructure have been installed serving uses not specifically regulated by San Francisco Building Code Section 106A.1.17.1. List systems below:	
	Indicate System(s):	Indicate Area(s). Include reference to plan sheets and AB-005 approval.
	_____	_____

As the Design Professional of Record, I verify the project has been constructed to comply with San Francisco's Building Code Section 106A.1.17.1.

Every area served by gas piping (as indicated above) has been designed and constructed for future conversion to all-electric, in a manner consistent with AB-112 *Design Guideline for Electric Ready Buildings* to the maximum extent possible. All conditions approved under AB-005 for provision of equivalent health, safety, and fire-protection have been fulfilled.

Signed: _____ Date: _____

Affix professional stamp:

Staff Use Only: Project has been inspected: Sign & Date:

Summary of Findings

San Francisco Zero Emission Buildings Taskforce: New Construction Work Group – June 2020

About the Zero Emission Buildings Taskforce

San Francisco has long recognized the economic, public health, and quality-of-life benefits of climate action. In 2018, San Francisco Supervisor Raphael Mandelman led the Board of Supervisors to approve a declaration of Climate Emergency, and San Francisco Mayor Breed joined 23 mayors from around the world in signing C40’s [Net Zero Carbon Buildings Declaration](#), committing to eliminate carbon emissions from new construction citywide no later than 2030, and eliminate emissions from all buildings in the city by mid-century. To further the City’s commitment to climate action, racial equity and a just transition, Mayor Breed directed the Department of Environment to convene a Zero Emission Building Taskforce (ZEBT). The ZEBT gathered leaders from across the building sector to provide guidance on how best to fulfill the City’s commitments equitably and effectively.

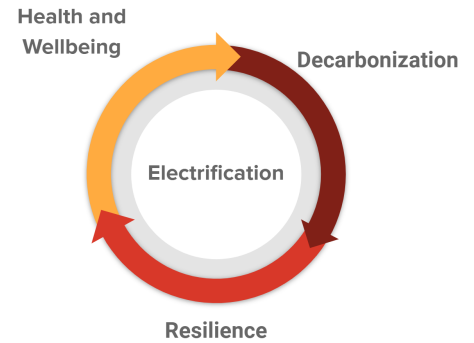

“An all-electric City for buildings, residences and transportation is how the City leads the way towards an emissions-free future.”

- Mayor London Breed, April 22, 2019

This document summarizes the outreach to and feedback from the New Construction Workgroup of the ZEBT. The New Construction workgroup was established to inform Supervisor Rafael Mandelman’s ordinance proposing to require new buildings to be “all-electric”. The City requested guidance on timing, applicability, implementation, and equity of the ordinance, as well as support and follow up necessary to successfully transition to all-electric new construction. Both Mayor Breed and Supervisor Mandelman demanded inclusivity in the process, and equity in implications.

Stakeholder Outreach

The City is committed to extensive outreach and education for San Franciscans about the climate emergency and the City’s goals, as well as transparency in data & analyses that inform policies and programs. The workgroup brought together participants from key perspectives, including community and neighborhood advocacy groups, affordable housing developers, commercial and residential owners and developers, investors, design professionals, environmental advocates, workforce and labor representatives, and City departments. Staff provided supporting technical, legal, financial, and budgetary analysis, as well as considerations of administrative practicality.

Workgroup Representation

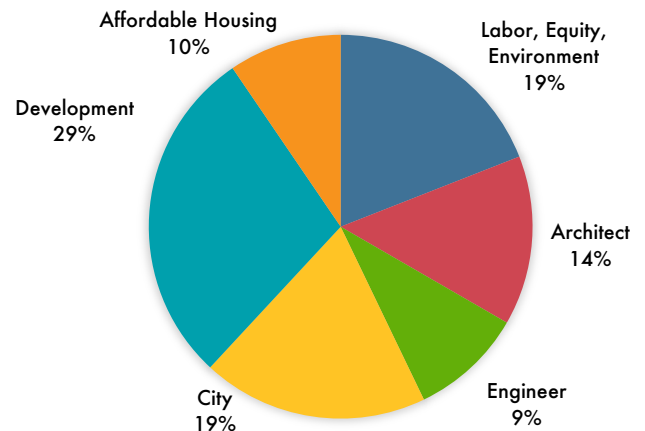



In addition to meetings of the workgroup, the City hosted a well-attended kickoff workshop and meetings reviewing specific issues or in-depth considerations & concerns.

Outreach Events

Date	Event	Participants
Jan 8	Kickoff Workshop: <i>Building the All-Electric City</i>	72
Jan 24	ZEBT New Construction Workgroup Meeting #1	19
Feb 19	ZEBT New Construction Workgroup Meeting #2	17
Feb 19	Presentation to Bayview Hunters Point Environmental Justice Response Task Force	23
Feb 20	Presentation to Building Owners & Managers Association of San Francisco, Energy & Environment Committee	19
Feb 24	ZEBT – Executive Steering Committee	21
Feb 25	San Francisco Energy Fair – Public expo on electrification	450
April 3	ZEBT New Construction Workgroup Meeting #3	19
Apr 23	All Electric New Construction: Considerations for Affordable Housing	41
May 12	Exceptions Process Review	11
May 15	Draft All Electric Ordinance: Considerations for Restaurants	8
May 18	ZEBT – Executive Steering Committee	28
May 29	All Electric New Construction: Infill Sidewalk Electric Vaults	22
June 19	Draft All Electric Ordinance: Check-in with Climate Emergency Coalition	9

Precedent

From 2017-2019, Marin County, Palo Alto, San Francisco, and other California jurisdictions adopted local laws to incentivize all-electric design. These laws increased energy efficiency requirements for “mixed fuel” buildings (e.g. buildings that use natural gas), while maintaining requirements for all-electric buildings. These actions became a statewide trend within the last year: 30 local governments around California have passed policies to support electrification in new construction. Several Bay Area cities, including Berkeley, San Jose, and Menlo Park adopted policies that went further, eliminating natural gas, primarily in single-family homes and low-rise multifamily buildings. In January 2020, San Francisco adopted an ordinance eliminating



natural gas in newly constructed municipal buildings, and an ordinance which favors electrification in residential and commercial buildings by increasing energy performance requirements for buildings that install gas systems.

Supervisor Raphael Mandelman challenged the ZEBT New Construction Workgroup to take the next step: an ordinance requiring the elimination of natural gas from new construction for the benefit of public health, fire safety, and climate action. For San Francisco, the logic of electrification is clear and was presented by Department of Environment staff during the public kickoff meeting of the New Construction Workgroup:

- **Decarbonization of grid-supplied electricity is happening rapidly.** The San Francisco Department of the Environment (SFE) [Climate Storyboard](#) shows that emissions from operation of buildings citywide declined 51% from 1990 to 2018 due to grid decarbonization and energy efficiency.
- **Emissions from electricity use in San Francisco are on the path to zero.** Today natural gas represents 82% of remaining emissions from buildings in San Francisco.
- **Electrification of the remaining fossil fuel energy uses in San Francisco buildings is required to reach zero emissions.** In the near future, natural gas-fired boilers, water heaters, furnaces, ovens, ranges, and clothes dryers will comprise virtually all the greenhouse gas emissions from San Francisco's buildings. Eliminating these emissions by switching to carbon-free energy for space and water heating, creating what the Mayor has called an 'all electric city,' is the new strategy to reach zero emissions.

In response, the New Construction Workgroup provided the following feedback about timing, applicability, implementation, and equity of the ordinance:

Act now - Delay will not make transition easier. The future is electric. It is urgent to halt future emissions by no longer constructing buildings that use natural gas. Leaders in design and construction are aware of the case for electrification and how to deliver it, but direct and consistent messaging from the City on the 'all-electric' future must continue. Costs are competitive and technology is available. Complexities for some use types (e.g. power supply for small in-fill projects, restaurant cooking methods, and complex process loads) may require exceptions in some cases. Clear and urgent communication from the City will spur already permitted projects (where a new mandate cannot apply) to consider electrification to avoid future re-engineering costs (e.g. if the building is to be sold).

Health and resilience are equity imperatives. Many stakeholders are not aware of outage times for the electrical systems compared to the gas network after a seismic event,¹ or the health impacts of indoor combustion of fossil fuels – the consequences of which are magnified for low-income communities and communities of color that already suffer greater prevalence of asthma due to poor indoor air quality. These co-benefits join carbon reduction to justify electrifying new construction. A focus on health and resilience also underscores that electrification must not delay the development of much-needed affordable housing.

Help projects make smart design choices. As San Francisco buildings decarbonize, any new natural-gas-using equipment will become a liability for building owners. The City must communicate now, and repeatedly, with project teams and developers about this shift. Compared to all existing buildings, few projects are impacted, but the impact on individual projects nearing completion of design could be significant. Project costs grow with each delay and any time redesign is

¹ It is estimated that after a 7.9 earthquake it would take six months to restore gas services citywide, while electricity could be restored in less than a week. Source: San Francisco Lifelines Council (2014) "Lifelines Interdependency Study"

[sfgov.org/orr/sites/default/files/documents/Lifelines%20Council%20Interdependency%20Study.pdf](https://www.sfgov.org/orr/sites/default/files/documents/Lifelines%20Council%20Interdependency%20Study.pdf)



required. In all cases, earlier notice mitigates the impact. By aligning City policies and programs, the City can send and reinforce a clear message of electrification and find creative ways to help owners and developers make timely, cost-effective decarbonization decisions. Coordinating with PG&E and SFPUC to ensure grid capacity and to provide a clear map of utility infrastructure can further inform building applicants' plans.

Workforce development and stakeholder education are essential. Projects transitioning to all-electric new will spur the workforce to evolve. To support the equitable growth and retention of a diverse workforce, as well as a just transition, it will be necessary for construction training and workforce development programs to train workers on installation and maintenance of zero carbon electric equipment and provide the pathways to employment necessary to construct the All-Electric City.

In parallel, design and construction professionals understand the City's message that policy has changed and the necessary electrification is both cost effective and technically feasible. This City must invest in education and partner with local institutions and utilities to smooth out the learning curve and support a successful transition.

New Construction Workgroup Input	Findings	*Fine Print
Act now - delay will not make transition easier.	Efficient zero emission technologies are available and fossil fuel systems in new construction will become liabilities for owners.	An All Electric City will take time to build. The Climate Emergency is underway. Stop adding to the problem. Demand spurred by new construction requirements will help the workforce evolve.
Health and resilience are paramount to equity.	Health, wellbeing and resilience support eliminating fossil fuels.	After seismic events, electric service will recover much faster than gas - with implications for building operations. Electrification must not thwart housing development.
Facilitate smart decisions.	Projects in development will benefit from early warning; a clear, unambiguous message from the city will help.	A rapid change in requirements will be felt strongly by a handful of projects already in design – but fixing the problem now avoids the need to retrofit in the future. Communicate now, so they have time to act.
Workforce development and stakeholder education are essential.	Zero emissions is a significant shift in design and construction practice.	Successful implementation of the ordinance will require the city to invest resources in outreach and education, and to support workforce training.

For detailed meeting agendas, notes and presentations, see SF Environment's web page: [Zero Emission Building Taskforce](#).

Contributions

Summary prepared by:

Lane Wesley Burt, P.E., [Ember Strategies, LLC](#)

Jeremy Sigmon

With thanks to:

Michelle Vigen-Ralston, Common Spark Consulting

Barry Hooper, Department of Environment

Cyndy Comerford, Department of Environment



New Construction Workgroup

Name	Organization	Representation
Cindy Wu	Chinatown Community Development Corp	Affordable Housing
Ruchi Shah	Tenderloin Neighborhood Development Corp	Affordable Housing
Scott Shell	EHDD Architects	Architect
Hilary Noll	Mithun	Architect
J. Edgar "Ned" Fennie	Fenny Mehl Architecture	Architect
Danny Murtagh	Boston Properties	Development
John O'Connor	San Francisco Residential Builders Association	Development
Enrique Landa	Associate Capital	Development
Terezia Nemeth	Alexandria Real Estate	Development
Fran Weld	San Francisco Giants	Development
Andrea Granados	JMA Ventures LLC	Development
Stet Sanborn	SmithGroup	Engineer
Ted Tiffany	Guttman & Blaevoet	Engineer
Michelle Pierce	Bayview Hunters Point Community Advocates	Equity and Environmental Advocate
Avni Jamdar	Emerald Cities	Labor and Equity Advocate
Pierre Del Forge	NRDC	Environmental Advocate
David Fahy	San Francisco Local 38 Plumbers & Pipefitters	Labor
Richard Berman	Port of San Francisco	City
Lisa Fisher	Planning Department	City
James Zhan	Department of Building Inspection	City
Joshua Arce	Mayor's Office of Economic and Workforce Development	City



New Construction Workgroup, Continued

Facilitation and Support		
Cyndy Comerford	Department of Environment	SFE Staff
Barry Hooper	Department of Environment	SFE Staff
Brian Reyes	Department of Environment	SFE Staff
Michelle Vigen Ralston	Common Spark Consulting	Facilitator
Jack Chang	Common Spark Consulting	Support
Lane Burt	Ember Strategies	Advisor



SF Environment

Our home. Our city. Our planet.

A Department of the City and County of San Francisco

All-Electric New Construction Ordinance

Land Use and Transportation Committee - September 21, 2020

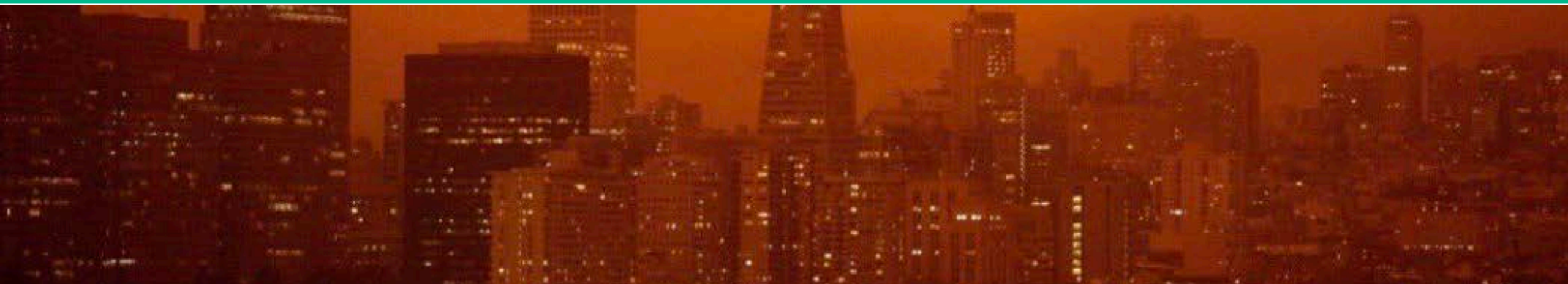

Today's Objectives



1. Emissions and Progress
2. Benefits of Building Electrification
3. Stakeholder Process and Outreach
4. Key Components of Ordinance
5. Cost and Equity Analysis
6. Discussion

Sources of San Francisco GHG Emissions (2018)

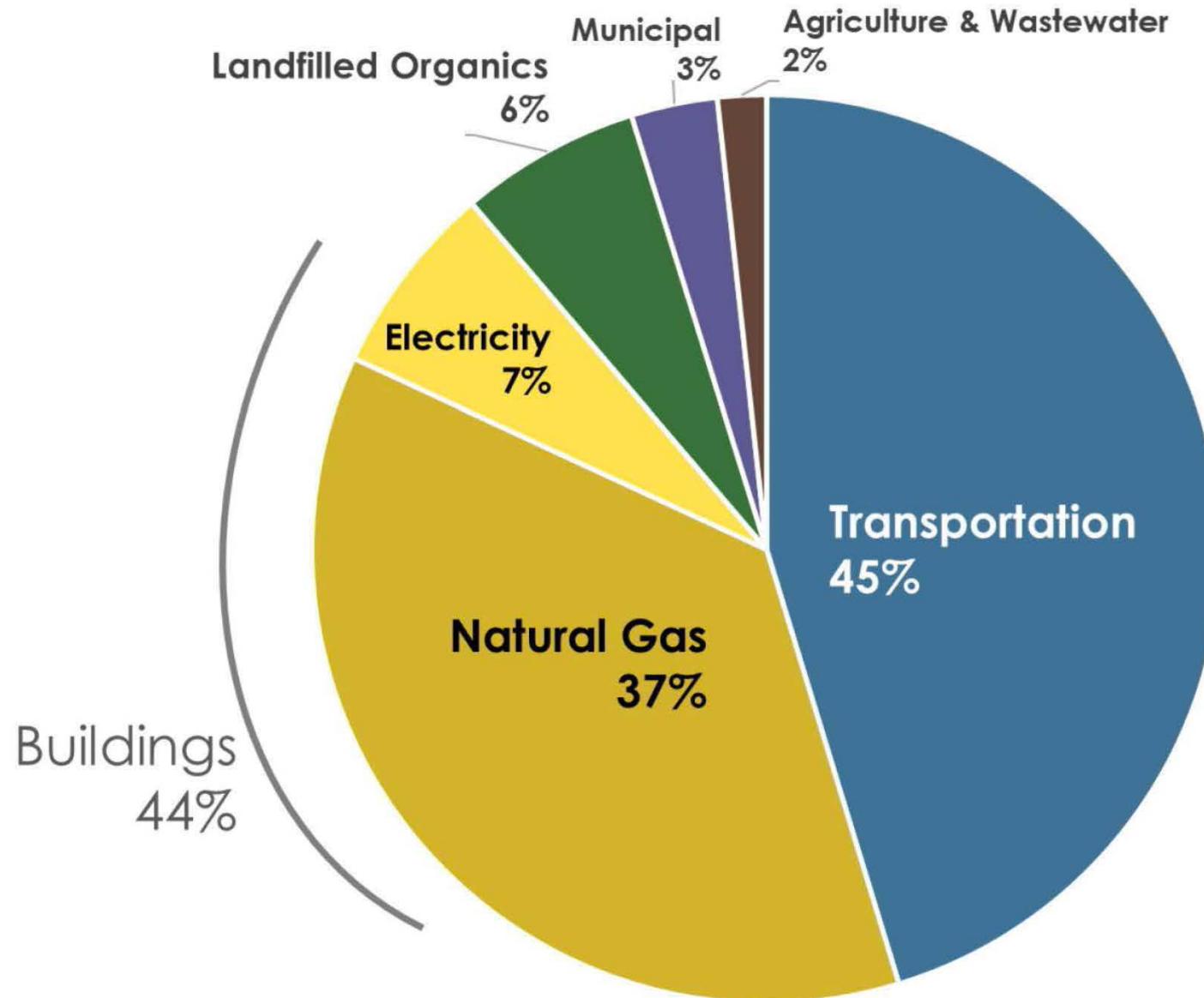

Emissions for San Francisco (1990 – 2018)



22%

Population

172%

GDP

2017

36%

Emissions below 1990 levels

2018

35%

The Zero Emission City

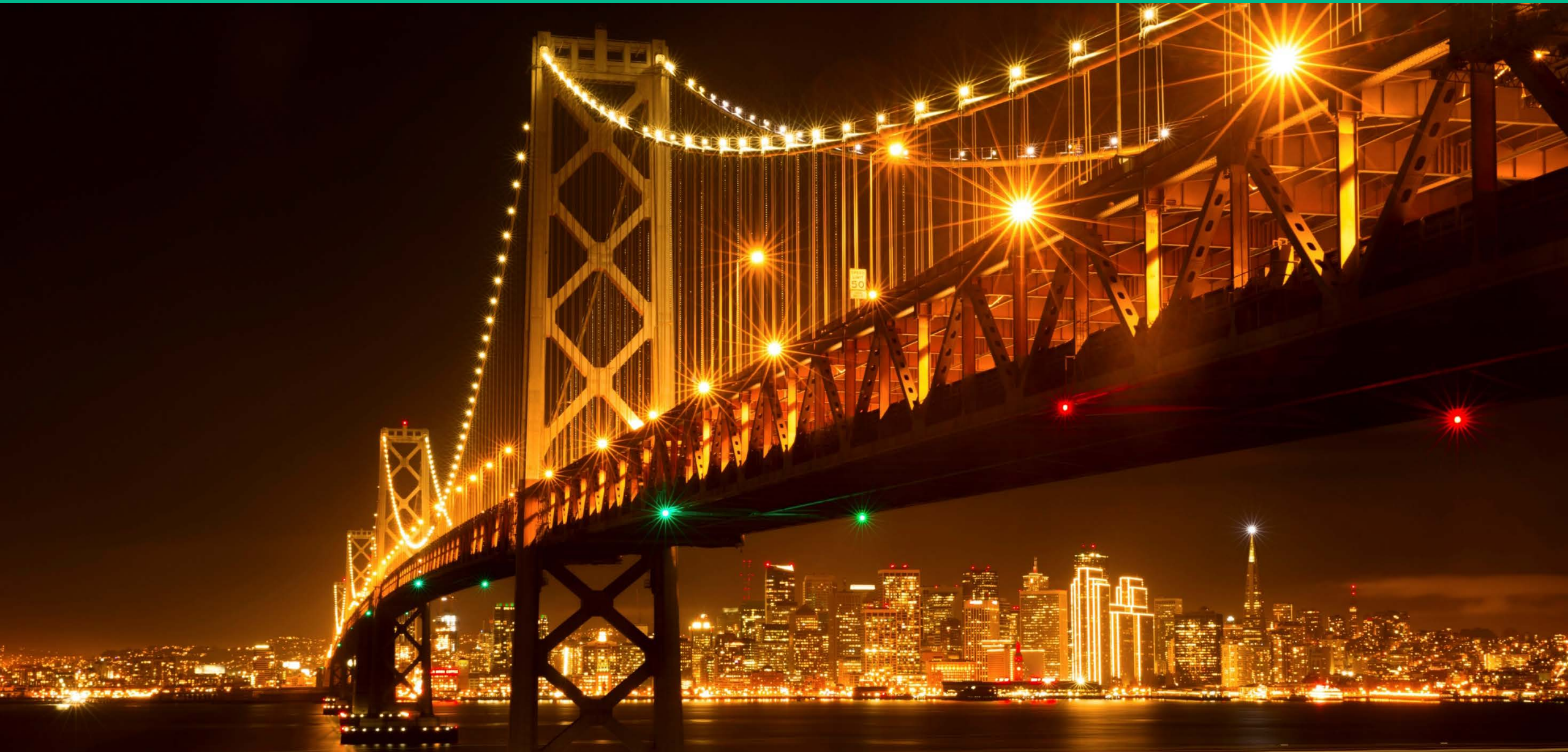



Benefits of Building Electrification

Natural gas impacts . . .



Health



Safety



Resilience



Equity



Stakeholder Process and Outreach

Zero Emission Building Taskforce

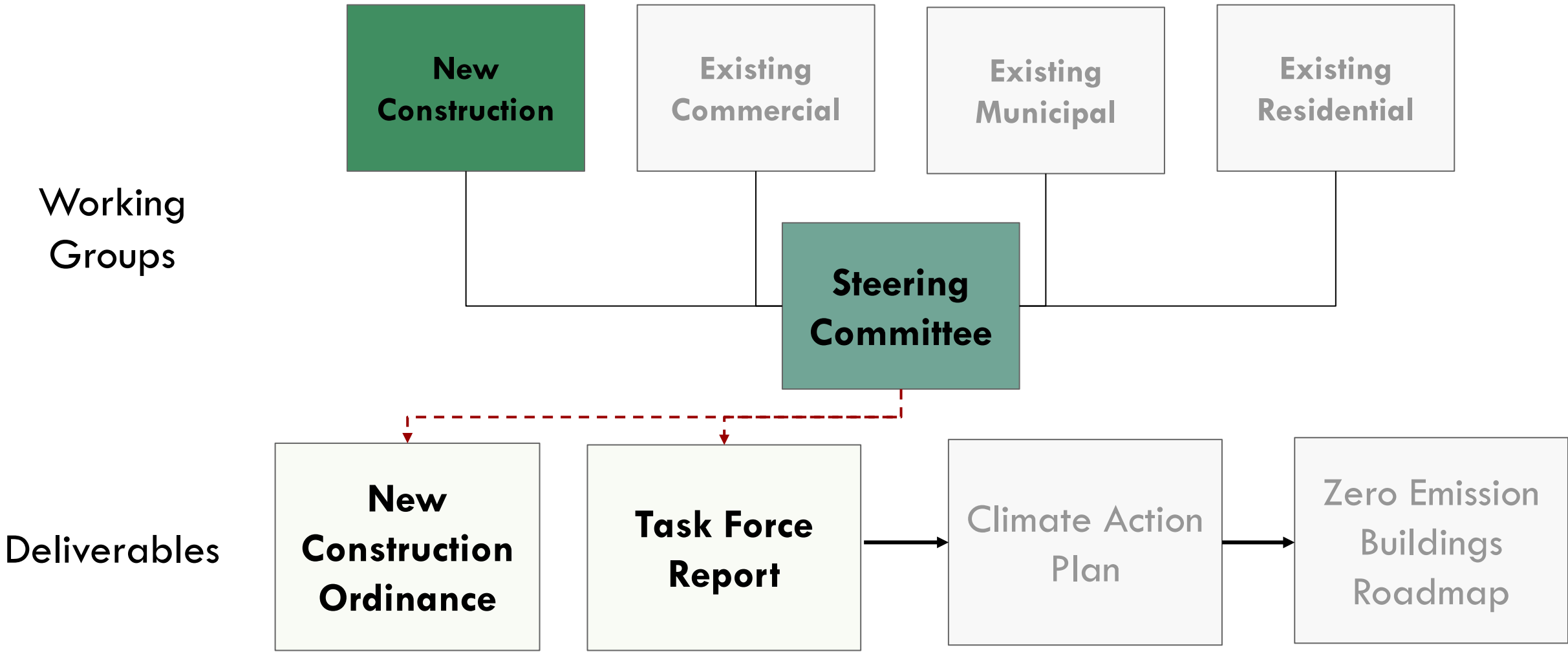

Overview of Outreach Efforts



15 Convenings
750+ People

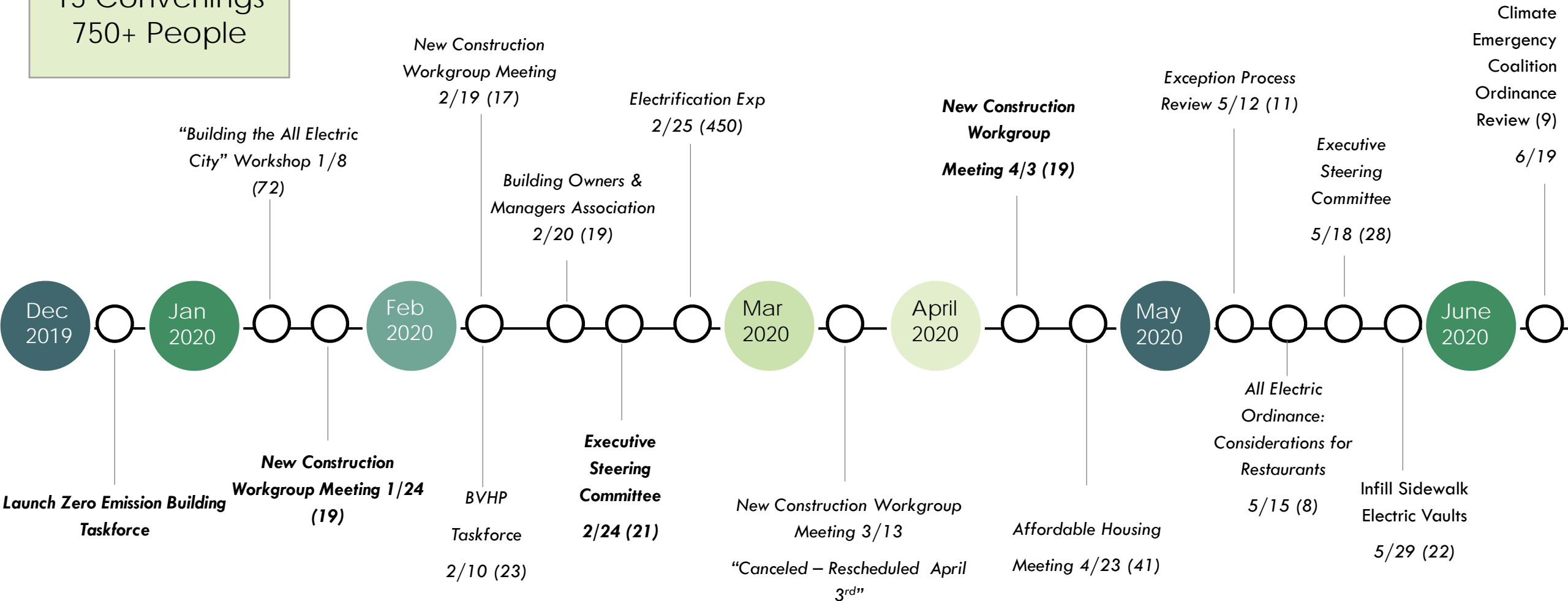



All Electric New Construction Ordinance

Key Components of the Ordinance



01

For projects that apply for building permits after January 1, 2021 – heating, cooling, water heating, cooking and clothes drying must be all electric.

02

No permits will be issued to convert all-electric buildings into mixed-fuel buildings



Key Components of the Ordinance



03

For projects that include a commercial food service establishment, mixed-fuel building permits may continue to be accepted until January 1, 2022 provided gas piping is exclusively for cooking equipment.

04

Mixed-fuel permits may be issued only upon finding that All-Electric construction is physically or technically infeasible for a specific area or system

05

Mixed-fuel permits must be as “Electric Ready” as feasible while complying with all provisions of building and electrical codes.

The Exception Process: Narrow & Specific



Case by case basis
– there are no
blanket exceptions



Exceptions are
limited to
infeasibility



Limited to the
area/system that
cannot all be electric



Exceptions would
need to be electric
ready



Cost and Equity Analysis

Cost and Benefits – Studies



	Change in Construction Cost (\$/Sq Ft)	Lifetime Net Present Value (\$/Sq Ft)
Single Family	-\$5.01	\$3.62
Multifamily 3 floors or less	-\$1.18	\$4.64
Multifamily 4-8 floors	-\$0.13	\$0.68
Retail	-\$0.98	\$6.37
Office	-\$1.54	\$1.09

Sources:

Low-Rise Residential: Frontier Energy (2019)

Mid-Rise Residential: Frontier Energy (2020)

Non-Residential: TRC (2019)

Supplemental Analysis by Dept of Environment to account for San Francisco Better Roofs requirements

Equity Scan Assessment

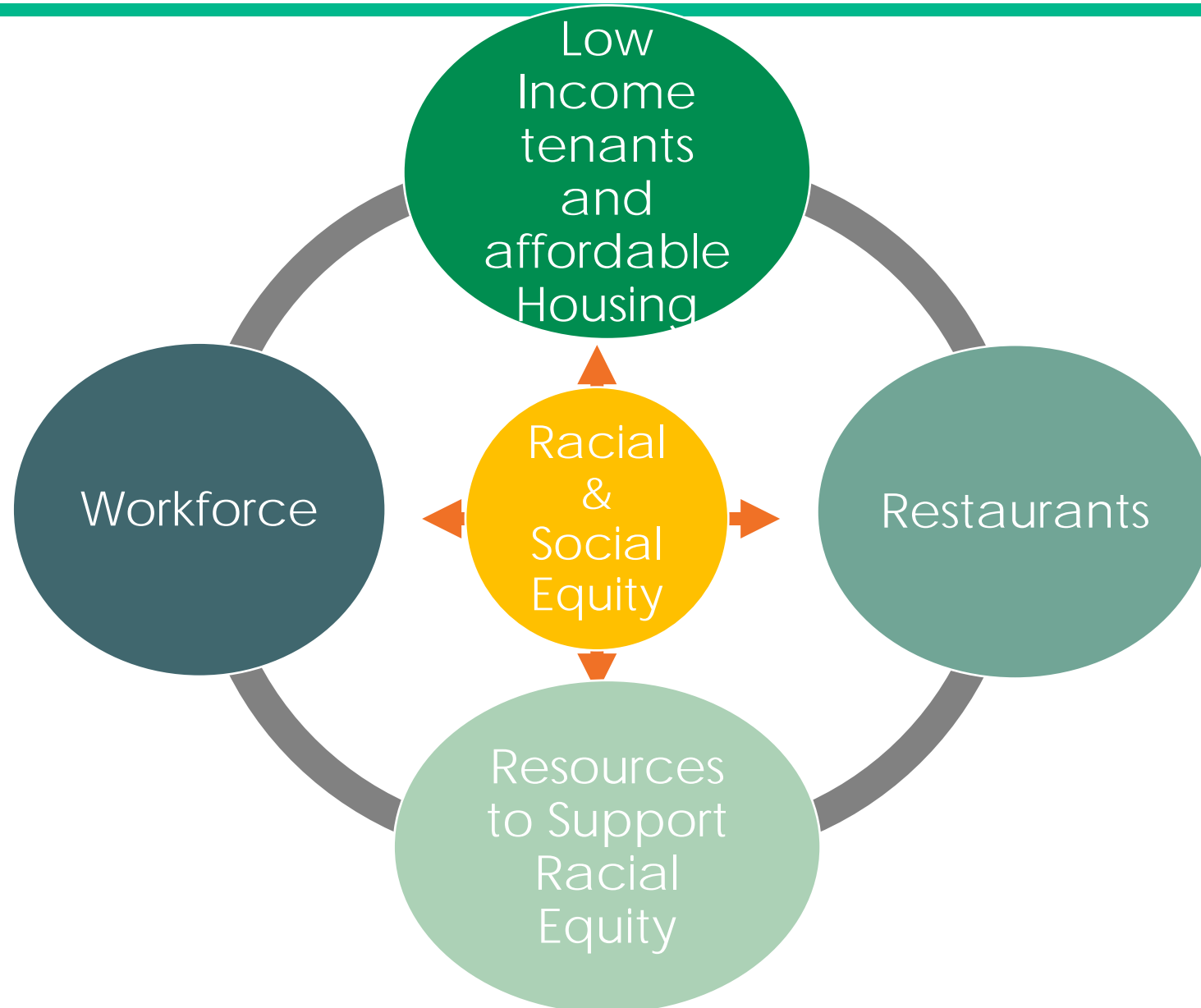

The future is already here – SF all electric buildings



2060 Folsom - Casa Adelante – Affordable
CCDC, MEDA, Mithun



Southeast Community Center - Municipal
SFPUC, SFPW



SFSU Student Housing Block 6
SFSU, Gould Evans, Point Energy Innovations, BuildGroup



685 Florida St – Infill
Off The Grid Design, RG Architecture



Claire Lilienthal Elementary School - SFUSD
SFUSD, Lionakis

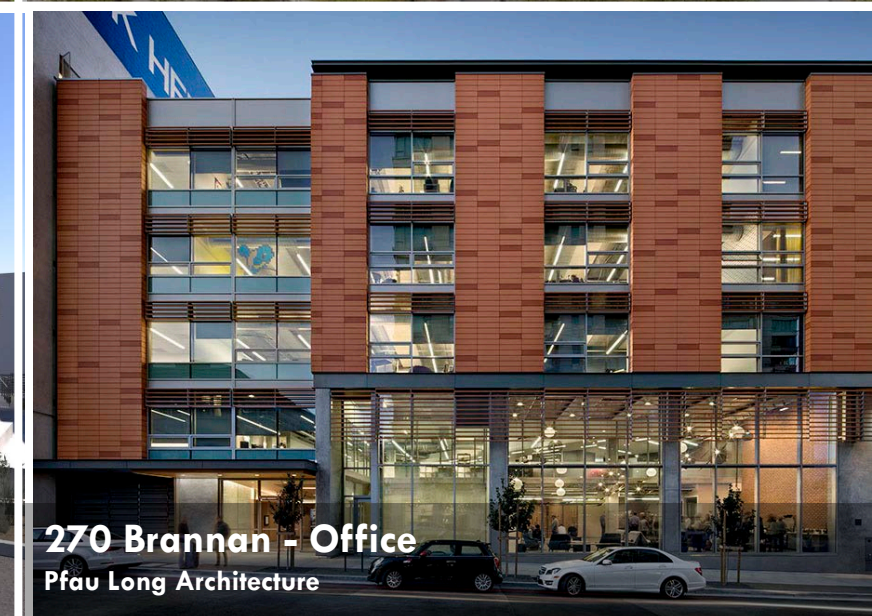

270 Brannan - Office
Pfau Long Architecture

Thank you



Debbie Raphael, Director
deborah.raaphael@sfgov.org

Cyndy Comerford, Climate Program Manager
cyndy.comerford@sfgov.org



SF Environment

Our home. Our city. Our planet.

A Department of the City and County of San Francisco

SF Environment All Rights Reserved

The author of this document has secured the necessary permission to use all the images depicted in this presentation. Permission to reuse or repurpose the graphics in this document should not be assumed nor is it transferable for any other use. Please do not reproduce or broadcast any content from this document without written permission from the holder of copyright.

BOARD of SUPERVISORS



City Hall
Dr. Carlton B. Goodlett Place, Room 244
San Francisco 94102-4689
Tel. No. 554-5184
Fax No. 554-5163
TDD/TTY No. 554-5227

July 8, 2020

File No. 200701

Lisa Gibson
Environmental Review Officer
Planning Department
1650 Mission Street, Ste. 400
San Francisco, CA 94103

Dear Ms. Gibson:

On June 30, 2020, Supervisor Mandelman submitted the following legislation:

File No. 200701

Ordinance amending the Building Code to require new construction to utilize only electric power; adopting findings of local conditions under the California Health and Safety Code; affirming the Planning Department's determination under the California Environmental Quality Act; and directing the Clerk of the Board of Supervisors to forward this Ordinance to the California Building Standards Commission upon final passage.

This legislation is being transmitted to you for environmental review.

Angela Calvillo, Clerk of the Board

A handwritten signature in cursive script, appearing to read "Erica Major".

By: Erica Major, Assistant Clerk
Land Use and Transportation Committee

Attachment

c: Joy Navarrete, Environmental Planning
Don Lewis, Environmental Planning

BOARD of SUPERVISORS



City Hall
1 Dr. Carlton B. Goodlett Place, Room 244
San Francisco 94102-4689
Tel. No. 554-5184
Fax No. 554-5163
TDD/TTY No. 554-5227

MEMORANDUM

TO: Patrick O'Riordan, Director , Department of Building Inspection
Sonya Harris, Secretary, Building Inspection Commission

FROM: Erica Major, Assistant Clerk, Land Use and Transportation Committee

DATE: July 8, 2020

SUBJECT: LEGISLATION INTRODUCED

The Board of Supervisors' Land Use and Transportation Committee has received the following legislation, introduced by Supervisor Mandelman on June 30, 2020:

File No. 200701

Ordinance amending the Building Code to require new construction to utilize only electric power; adopting findings of local conditions under the California Health and Safety Code; affirming the Planning Department's determination under the California Environmental Quality Act; and directing the Clerk of the Board of Supervisors to forward this Ordinance to the California Building Standards Commission upon final passage.

The proposed ordinance is being transmitted pursuant to Charter, Section D3.750-5, for public hearing and recommendation. It is pending before the Land Use and Transportation Committee and will be scheduled for hearing upon receipt of your response.

Please forward me the Commission's recommendation and reports at the Board of Supervisors, City Hall, Room 244, 1 Dr. Carlton B. Goodlett Place, San Francisco, CA 94102 or by email at: Erica.Major@sfgov.org.

c: John Murray, Department of Building Inspection
Patty Lee, Department of Building Inspection

From: [Todd Snyder](#)
To: [Preston, Dean \(BOS\)](#); [Major, Erica \(BOS\)](#)
Subject: Public Comment Re: BoS File 200701
Date: Monday, October 19, 2020 9:05:47 AM

This message is from outside the City email system. Do not open links or attachments from untrusted sources.

I'm a resident of San Francisco writing to strongly support prohibiting gas in new construction. The methane leaks, air pollution, and explosion dangers of natural gas are no longer necessary for the functioning of our homes and businesses. San Francisco can lead the state and the country in building a better future.

I ask the Land Use and Transportation Committee to recommend the changes to the ordinance as laid out by Earthjustice, the Sierra Club, the SF Climate Emergency Coalition, PODER SF and more than 20 other organizations in their September 18 letter to the Committee, and recommend that amended ordinance to the full Board.

It is important to me that we:

1. Eliminate the feasibility exception to the electric-ready requirement and make fully electric-ready construction a baseline requirement for new construction. We know that the future is electric. Allowing any building to be built that will require massive retrofits in the near future is unacceptable. With full electric readiness, we minimize that retrofit cost.
2. Create a Clean Energy Building Hub through the City and County of San Francisco that provides for the outreach, resources, and education needed to eliminate barriers and maximize opportunity for all-electric new construction to benefit both climate and equity.
3. Expand the ordinance's definition of "mixed-fuel buildings" to include laboratory, industrial, and decorative uses of gas. Gas shouldn't be allowed for upscale decorative uses. It's wrong to harm public health for private enjoyment.
4. Provide additional limitations and transparency in the exemption process to ensure any project found exempt for infeasibility is truly in the public interest. I'm concerned about the news of powerful and connected people being able to get favors from DBI. We need sunshine on the exemption process, and exemptions should only be given in the public interest.
5. Amend section 106A.1.17 to require that the Building Official find "sufficient evidence was submitted to substantiate the infeasibility of an All-Electric Building or Project design without regard to financial, floor-area, or amenity-related loss unless deemed to be in the public welfare." The housing crisis is real. And we need to find ways of fixing it without sacrificing our children's future. The space taken up by a transformer should not be an acceptable reason for an exemption.

6. Eliminate the blanket exemption for commercial kitchens delaying compliance until 2022. Existing restaurants are not helped by giving builders a pass on making future commercial kitchens all-electric.

Thank you for taking up this important issue and considering the health and safety of our residents and climate.

Sincerely,

Todd Snyder

1941 Turk street #4

From: [Gabriel Goffman](#)
To: [Major, Erica \(BOS\)](#); [Board of Supervisors, \(BOS\)](#); [Preston, Dean \(BOS\)](#); [Peskin, Aaron \(BOS\)](#); [Safai, Ahsha \(BOS\)](#); [MandelmanStaff, \(BOS\)](#); [Stefani, Catherine \(BOS\)](#)
Subject: Public Comment Re: BoS File 200701
Date: Monday, October 19, 2020 2:13:07 PM

This message is from outside the City email system. Do not open links or attachments from untrusted sources.

Land Use Committee, Board of Supervisors, and Sup. Stefani,

I'm a resident of San Francisco writing to strongly support prohibiting gas in new construction. The methane leaks, air pollution, and explosion dangers of natural gas are no longer necessary for the functioning of our homes and businesses. San Francisco can lead the state and the country in building a better future.

In addition to recommending the ordinance, I would also like to ask the Commission to recommend the changes to the ordinance as laid out by Earthjustice, the Sierra Club, the San Francisco Climate Emergency Coalition, and other local groups in their letter to the Commission and Board.

It is important to me that we:

1. Eliminate the feasibility exception to the electric-ready requirement and make fully electric-ready construction a baseline requirement for new construction. We know that the future is electric. Allowing any building to be built that will require massive retrofits in the near future is unacceptable. With full electric readiness, we minimize that retrofit cost.
2. Create a Clean Energy Building Hub through the City and County of San Francisco that provides for the outreach, resources, and education needed to eliminate barriers and maximize opportunity for all-electric new construction to benefit both climate and equity.
3. Expand the ordinance's definition of "mixed-fuel buildings" to include laboratory, industrial, and decorative uses of gas. Gas shouldn't be allowed for upscale decorative uses. It's wrong to harm public health for private enjoyment.
4. Provide additional limitations and transparency in the exemption process to ensure any project found exempt for infeasibility is truly in the public interest. I'm concerned about the news of powerful and connected people being able to get favors from DBI. We need sunshine on the exemption process, and exemptions should only be given in the public interest.
5. Amend section 106A.1.17 to require that the Building Official find "sufficient evidence was submitted to substantiate the infeasibility of an All-Electric Building or Project design without regard to financial, floor-area, or amenity-related loss unless deemed to be in the public welfare." The housing crisis is real. And we need to find ways of fixing it without sacrificing our children's future. The space taken up by a transformer should not be an acceptable reason for

an exemption.

6. Eliminate the blanket exemption for commercial kitchens delaying compliance until 2022. Existing restaurants are not helped by giving builders a pass on making future commercial kitchens all-electric.

Thank you for taking up this important issue and considering the health and safety of our residents and climate.

Gabriel Goffman
gfgoffman@gmail.com
2300 webster st 603
San Francisco, California 94115

From: [Barbara Jue](#)
To: [Major, Erica \(BOS\)](#); [Board of Supervisors, \(BOS\)](#); [Preston, Dean \(BOS\)](#); [Peskin, Aaron \(BOS\)](#); [Safai, Ahsha \(BOS\)](#); [MandelmanStaff, \(BOS\)](#); [Haney, Matt \(BOS\)](#)
Subject: Public Comment Re: BoS File 200701
Date: Monday, October 19, 2020 9:04:33 AM

This message is from outside the City email system. Do not open links or attachments from untrusted sources.

Land Use Committee, Board of Supervisors, and Sup. Haney,

I am a resident of District 6 and want to express my support for banning natural gas in new construction. It's polluting and its use is dangerous to life and property. I worry about gas leaks especially in earthquake zones like ours, and having witnessed the fires from Loma Prieta in '89. On average in the US, a natural gas or oil pipeline catches fire every four days, results in an injury every five days, explodes every 11 days, and leads to a fatality every 26 days. My East Cut neighborhood is now replete with new gas lines/hookups that weren't there before because of all the residential construction that's taken place in the last ten years.

I would also like to ask the Commission to recommend the changes to the ordinance as laid out by Earthjustice, the Sierra Club, the San Francisco Climate Emergency Coalition, and other local groups in their letter to the Commission and Board.

It is important to me that we:

1. Eliminate the feasibility exception to the electric-ready requirement and make fully electric-ready construction a baseline requirement for new construction. We know that the future is electric. Allowing any building to be built that will require massive retrofits in the near future is unacceptable. With full electric readiness, we minimize that retrofit cost.
2. Create a Clean Energy Building Hub through the City and County of San Francisco that provides for the outreach, resources, and education needed to eliminate barriers and maximize opportunity for all-electric new construction to benefit both climate and equity.
3. Expand the ordinance's definition of "mixed-fuel buildings" to include laboratory, industrial, and decorative uses of gas. Gas shouldn't be allowed for upscale decorative uses. It's wrong to harm public health for private enjoyment.
4. Provide additional limitations and transparency in the exemption process to ensure any project found exempt for infeasibility is truly in the public interest. I'm concerned about the news of powerful and connected people being able to get favors from DBI. We need sunshine on the exemption process, and exemptions should only be given in the public interest.
5. Amend section 106A.1.17 to require that the Building Official find "sufficient evidence was submitted to substantiate the infeasibility of an All-Electric Building or Project design without regard to financial, floor-area, or amenity-related loss unless deemed to be in the public

welfare." The housing crisis is real. And we need to find ways of fixing it without sacrificing our children's future. The space taken up by a transformer should not be an acceptable reason for an exemption.

6. Eliminate the blanket exemption for commercial kitchens delaying compliance until 2022. Existing restaurants are not helped by giving builders a pass on making future commercial kitchens all-electric.

Thank you for taking up this important issue and considering the health and safety of our residents and climate.

Barbara Jue
sfbar48@gmail.com
81 Lansing Street, #411
San Francisco, California 94105

From: [Samuel Plunkett](#)
To: [Major, Erica \(BOS\)](#); [Board of Supervisors, \(BOS\)](#); [Preston, Dean \(BOS\)](#); [Peskin, Aaron \(BOS\)](#); [Safai, Ahsha \(BOS\)](#); [MandelmanStaff, \(BOS\)](#); [Mar, Gordon \(BOS\)](#)
Subject: Public Comment Re: BoS File 200701
Date: Monday, October 12, 2020 12:27:11 PM

This message is from outside the City email system. Do not open links or attachments from untrusted sources.

Land Use Committee, Board of Supervisors, and Sup. Mar,

I'm a resident of San Francisco writing to strongly support prohibiting gas in new construction. The methane leaks, air pollution, and explosion dangers of natural gas are no longer necessary for the functioning of our homes and businesses. San Francisco can lead the state and the country in building a better future.

In addition to recommending the ordinance, I would also like to ask the Commission to recommend the changes to the ordinance as laid out by Earthjustice, the Sierra Club, the San Francisco Climate Emergency Coalition, and other local groups in their letter to the Commission and Board.

It is important to me that we:

1. Eliminate the feasibility exception to the electric-ready requirement and make fully electric-ready construction a baseline requirement for new construction. We know that the future is electric. Allowing any building to be built that will require massive retrofits in the near future is unacceptable. With full electric readiness, we minimize that retrofit cost.
2. Create a Clean Energy Building Hub through the City and County of San Francisco that provides for the outreach, resources, and education needed to eliminate barriers and maximize opportunity for all-electric new construction to benefit both climate and equity.
3. Expand the ordinance's definition of "mixed-fuel buildings" to include laboratory, industrial, and decorative uses of gas. Gas shouldn't be allowed for upscale decorative uses. It's wrong to harm public health for private enjoyment.
4. Provide additional limitations and transparency in the exemption process to ensure any project found exempt for infeasibility is truly in the public interest. I'm concerned about the news of powerful and connected people being able to get favors from DBI. We need sunshine on the exemption process, and exemptions should only be given in the public interest.
5. Amend section 106A.1.17 to require that the Building Official find "sufficient evidence was submitted to substantiate the infeasibility of an All-Electric Building or Project design without regard to financial, floor-area, or amenity-related loss unless deemed to be in the public welfare." The housing crisis is real. And we need to find ways of fixing it without sacrificing our children's future. The space taken up by a transformer should not be an acceptable reason for

an exemption.

6. Eliminate the blanket exemption for commercial kitchens delaying compliance until 2022. Existing restaurants are not helped by giving builders a pass on making future commercial kitchens all-electric.

Thank you for taking up this important issue and considering the health and safety of our residents and climate.

Samuel Plunkett
samgplunkett@gmail.com
1862 46th Avenue
SAN FRANCISCO, California 94122

From: [Amy Keith](#)
To: [Major, Erica \(BOS\)](#); [Board of Supervisors, \(BOS\)](#); [Preston, Dean \(BOS\)](#); [Peskin, Aaron \(BOS\)](#); [Safai, Ahsha \(BOS\)](#); [MandelmanStaff, \[BOS\]](#)
Subject: Public Comment Re: BoS File 200701 (Item 2 of 10/5 Land Use)
Date: Tuesday, October 6, 2020 1:21:59 PM

This message is from outside the City email system. Do not open links or attachments from untrusted sources.

Land Use Committee, Board of Supervisors, and Sup. Mandelman,

I'm a resident of San Francisco in District 8 writing to strongly support prohibiting gas in new construction. The methane leaks, air pollution, and explosion dangers of natural gas are no longer necessary for the functioning of our homes and businesses. San Francisco can lead the state and the country in building a better future.

In addition to recommending the ordinance, I would also like to ask the Commission to recommend the changes to the ordinance as laid out by Earthjustice, the Sierra Club, the San Francisco Climate Emergency Coalition, and other local groups in their letter to the Commission and Board.

It is important to me that we:

1. Eliminate the feasibility exception to the electric-ready requirement and make fully electric-ready construction a baseline requirement for new construction. We know that the future is electric. Allowing any building to be built that will require massive retrofits in the near future is unacceptable. With full electric readiness, we minimize that retrofit cost.
2. Create a Clean Energy Building Hub through the City and County of San Francisco that provides for the outreach, resources, and education needed to eliminate barriers and maximize opportunity for all-electric new construction to benefit both climate and equity.
3. Expand the ordinance's definition of "mixed-fuel buildings" to include laboratory, industrial, and decorative uses of gas. Gas shouldn't be allowed for upscale decorative uses. It's wrong to harm public health for private enjoyment.
4. Provide additional limitations and transparency in the exemption process to ensure any project found exempt for infeasibility is truly in the public interest. I'm concerned about the news of powerful and connected people being able to get favors from DBI. We need sunshine on the exemption process, and exemptions should only be given in the public interest.
5. Amend section 106A.1.17 to require that the Building Official find "sufficient evidence was submitted to substantiate the infeasibility of an All-Electric Building or Project design without regard to financial, floor-area, or amenity-related loss unless deemed to be in the public welfare." The housing crisis is real. And we need to find ways of fixing it without sacrificing our children's future. The space taken up by a transformer should not be an acceptable reason for

an exemption.

6. Eliminate the blanket exemption for commercial kitchens delaying compliance until 2022. Existing restaurants are not helped by giving builders a pass on making future commercial kitchens all-electric.

Thank you for taking up this important issue and considering the health and safety of our residents and climate.

Sincerely,
Amy Keith
527 Dolores St
Apt 4
SF, CA
94110

Amy Keith
amykeith7@gmail.com
527 Dolores St, Apt 4
San Francisco, California 94110

From: [Nik Evasco](#)
To: [Major, Erica \(BOS\)](#); [Board of Supervisors, \(BOS\)](#); [Preston, Dean \(BOS\)](#); [Peskin, Aaron \(BOS\)](#); [Safai, Ahsha \(BOS\)](#); [MandelmanStaff, \[BOS\]](#)
Subject: Public Comment Re: BoS File 200701 (Item 1 of 9/21 Land Use)
Date: Monday, October 5, 2020 12:56:43 PM

This message is from outside the City email system. Do not open links or attachments from untrusted sources.

Land Use Committee, Board of Supervisors, and Sup. Peskin,

Dear San Francisco Board of Supervisors,

My name is Nik Evasco.

I'm a resident of San Francisco residing in Supervisor Peskin's District writing to strongly support prohibiting gas in new construction. The methane leaks, air pollution, and explosion dangers of natural gas are no longer necessary for the functioning of our homes and businesses. San Francisco can lead the state and the country in building a better future.

In addition to recommending the ordinance, I would also like to ask the Commission to recommend the changes to the ordinance as laid out by Earthjustice, the Sierra Club, the San Francisco Climate Emergency Coalition, and other local groups in their letter to the Commission and Board.

It is important to me that we:

1. Eliminate the feasibility exception to the electric-ready requirement and make fully electric-ready construction a baseline requirement for new construction. We know that the future is electric. Allowing any building to be built that will require massive retrofits in the near future is unacceptable. With full electric readiness, we minimize that retrofit cost.
2. Create a Clean Energy Building Hub through the City and County of San Francisco that provides for the outreach, resources, and education needed to eliminate barriers and maximize opportunity for all-electric new construction to benefit both climate and equity.
3. Expand the ordinance's definition of "mixed-fuel buildings" to include laboratory, industrial, and decorative uses of gas. Gas shouldn't be allowed for upscale decorative uses. It's wrong to harm public health for private enjoyment.
4. Provide additional limitations and transparency in the exemption process to ensure any project found exempt for infeasibility is truly in the public interest. I'm concerned about the news of powerful and connected people being able to get favors from DBI. We need sunshine on the exemption process, and exemptions should only be given in the public interest.
5. Amend section 106A.1.17 to require that the Building Official find "sufficient evidence was submitted to substantiate the infeasibility of an All-Electric Building or Project design without

regard to financial, floor-area, or amenity-related loss unless deemed to be in the public welfare." The housing crisis is real. And we need to find ways of fixing it without sacrificing our children's future. The space taken up by a transformer should not be an acceptable reason for an exemption.

6. Eliminate the blanket exemption for commercial kitchens delaying compliance until 2022. Existing restaurants are not helped by giving builders a pass on making future commercial kitchens all-electric.

Thank you for taking up this important issue and considering the health and safety of our residents and climate.

All the best,
Nik

Nik Evasco
nikevasco@gmail.com
930 Post St., #26
San Francisco, California 94109

From: [Linda Ray](#)
To: [Major, Erica \(BOS\)](#); [Board of Supervisors, \(BOS\)](#); [Preston, Dean \(BOS\)](#); [Peskin, Aaron \(BOS\)](#); [Safai, Ahsha \(BOS\)](#); [MandelmanStaff, \(BOS\)](#); [Walton, Shamann \(BOS\)](#)
Subject: Public Comment Re: BoS File 200701 (Item 1 of 9/21 Land Use)
Date: Tuesday, September 29, 2020 9:59:24 AM

This message is from outside the City email system. Do not open links or attachments from untrusted sources.

Land Use Committee, Board of Supervisors, and Sup. Walton,

I'm a resident of San Francisco writing to strongly support prohibiting gas in new construction. The methane leaks, air pollution, and explosion dangers of natural gas are no longer necessary for the functioning of our homes and businesses. San Francisco can lead the state and the country in building a better future. I worked for many years as a Public Health Nurse and now know that children exposed to gas stoves and other appliances have a much higher rate of asthma than children in electric powered homes.

In addition to recommending the ordinance, I would also like to ask the Commission to recommend the changes to the ordinance as laid out by Earthjustice, the Sierra Club, the San Francisco Climate Emergency Coalition, and other local groups in their letter to the Commission and Board.

It is important to me that we:

1. Eliminate the feasibility exception to the electric-ready requirement and make fully electric-ready construction a baseline requirement for new construction. We know that the future is electric. Allowing any building to be built that will require massive retrofits in the near future is unacceptable. With full electric readiness, we minimize that retrofit cost.
2. Create a Clean Energy Building Hub through the City and County of San Francisco that provides for the outreach, resources, and education needed to eliminate barriers and maximize opportunity for all-electric new construction to benefit both climate and equity.
3. Expand the ordinance's definition of "mixed-fuel buildings" to include laboratory, industrial, and decorative uses of gas. Gas shouldn't be allowed for upscale decorative uses. It's wrong to harm public health for private enjoyment.
4. Provide additional limitations and transparency in the exemption process to ensure any project found exempt for infeasibility is truly in the public interest. I'm concerned about the news of powerful and connected people being able to get favors from DBI. We need sunshine on the exemption process, and exemptions should only be given in the public interest.
5. Amend section 106A.1.17 to require that the Building Official find "sufficient evidence was submitted to substantiate the infeasibility of an All-Electric Building or Project design without regard to financial, floor-area, or amenity-related loss unless deemed to be in the public

welfare." The housing crisis is real. And we need to find ways of fixing it without sacrificing our children's future. The space taken up by a transformer should not be an acceptable reason for an exemption.

6. Eliminate the blanket exemption for commercial kitchens delaying compliance until 2022. Existing restaurants are not helped by giving builders a pass on making future commercial kitchens all-electric.

Thank you for taking up this important issue and considering the health and safety of our residents and climate.

Linda Ray
dadaray@hotmail.com
1125 Potrero Ave.
San Francisco, California 94110

From: [Khoen Meisinger](#)
To: [Major, Erica \(BOS\)](#)
Cc: [Steve Guttman](#)
Subject: SF land Use & Transportation Committee Meeting - SF All Electric Ordinance - TESTIMONY NEEDED
Date: Monday, October 5, 2020 10:10:18 AM
Attachments: [AB112 Support Letter_Khoen Meisinger.pdf](#)

This message is from outside the City email system. Do not open links or attachments from untrusted sources.

Good morning Ms. Major,

Please see the attached letter in support of AB112. Let me know if you have any questions or concerns.

Thank you!
Khoen

Proud to be -
a [Just. organization](#) | “Best Place to Work” 2017 | Celebrating **60** years

Khoen K. Meisinger, HERS

Senior Engineer

Commissioning and Building Performance Modeling

d 707.523.3010 xt 309 c 707.308.5918



15 Third Street, Santa Rosa, CA 95401

HVAC, Plumbing, Fire Protection, Electrical, Lighting, Telecom/Technology
Commissioning, Building Performance Modeling, Net Zero
[www.gb-eng.com](#) | [Sonoma Green Business](#) | [San Francisco 2030 District](#)

October 05, 2020

Clerk of the Board
Land Use and Transportation Committee
San Francisco Board of Supervisors
1 Dr. Carlton B. Goodlett Place, Room 244
San Francisco, CA 94102

RE: Support for AB112 All-Electric New Construction Regulations

Dear Committee Members,

I am writing to express my full support for AB112, the All-Electric Buildings for New Construction ordinance, introduced for adoption on June 30, 2020, by Supervisor Mandelman. I work for Guttman & Blaevot Consulting Engineers and have personal experience commissioning two all-electric buildings, the UCSF Tideland project in San Francisco. We will also be commissioning two other all-electric buildings, the First Community Housing's Roosevelt Park Apartments in San Jose and the Tenderloin Neighborhood Development Corporation's 4200 Geary Street Housing project in San Francisco. These buildings demonstrate that we can design and build all-electric buildings. I support AB112 and believe that it is the path forward for California as a world leader to combat climate change as well as reduce the risk of fires and explosions associated with gas use.

The Department of the Environment has put forward a solid case for adopting this new ordinance. I agree that this ordinance is critical to:

- Fulfill the city's commitment to combating climate change.
- Strengthen our city's ability to get back to business quickly after an earthquake (as demonstrated by the superior resilience of the electrical grid compared to the natural gas infrastructure, as seen after Hurricanes Sandy and Katrina as well as the fires in Sonoma County in 2017 and 2019)
- Protect human health from the pollutants that cause both poor indoor and outdoor air quality, and address the disproportionate impact on the health of our low-income residents and communities of color from the resulting indoor and outdoor air pollution created by residential natural gas use.
- Reduce the risk of fires and explosions on a day to day basis, as well as in the case of an earthquake.

We should be thoughtful about helping those who see themselves as the "losers" as a result of this change, and seek innovative and meaningful ways to support them. But there is far more to gain by a much broader group of people, and over generations, by adopting these regulations.

Please be forward-thinking enough to take the necessary actions to place help make this ordinance the law in San Francisco.

Very Truly yours,



Khoeun Meisinger

From: [Helena B](#)
To: [Major, Erica \(BOS\)](#)
Cc: [Board of Supervisors \(BOS\)](#); [Preston, Dean \(BOS\)](#); [Peskin, Aaron \(BOS\)](#); [Safai, Ahsha \(BOS\)](#); [Ronen, Hillary](#); [Beinart, Amy \(BOS\)](#)
Subject: Public Comment Re: BoS File 200701
Date: Monday, October 5, 2020 9:30:33 AM

This message is from outside the City email system. Do not open links or attachments from untrusted sources.

Hello Board of Supervisors and Staff,

I am writing again to support strong all-electric new construction legislation, including the changes outlined in the September 18 letter to the Board of Supervisors signed by the SF Climate Emergency Coalition, Earthjustice, Sierra Club, PODER SF, Emerald Cities, and 20 other organizations.

I am grateful and pleased to be able to report that last time I wrote to my Supervisor, Hillary Ronen, about this, she wrote back, "I agree."

Incremental change with many caveats will no longer serve. Instead, we need an ordinance that

- closes the financial feasibility loophole-- electric feasibility should be determined without regard to floor area or amenity-related loss, and the space taken up by a transformer should not be a reason for an exemption,
- requires full electric readiness in *any* cases of exemption or exception, and
- maximizes equity with a clean energy Building Hub as outlined by PODER SF.

This fire season is not an anomaly. It fits the trend of more extreme, longer fire seasons with faster spreading fires (and more smoke) that is well-explained by the science of climate change, and it is terrifying. San Francisco **must lead** on climate solutions, both for the health and wellbeing of SF residents and to do our part to make possible a livable future.

And San Francisco **needs all-electric buildings**, now more than ever, not only because natural gas destroys our climate and is a deadly explosion risk, but also because unless we shift to all-electric buildings, there will be literally nowhere to go to escape poor air quality. Children growing up in homes with gas stoves already have a [42% increased risk of asthma](#). Now close all the windows.

With regard to restaurants/food service, please consider what it would be like to be a line cook in a gas-fueled kitchen on a hot, smoky day. Now imagine being in an induction-based kitchen that's [much cooler, with much cleaner air](#), and please eliminate the extension for permitting new commercial kitchens with gas.

I understand that there is a lot of pressure from developers for exemptions and loopholes, but people can be creative when it's required. I was chatting with a friend whose father is a developer-- said they will always petition for the status quo, but can work for the best outcomes if that's what's required of them. "Necessity is the mother of invention" and there's definitely necessity to change in the face of the climate emergency.

As San Francisco's elected officials, please make sure that private profit doesn't take precedence over the public good, and please listen to all the residents pleading for all-electric new construction legislation as a critical first step in addressing the climate emergency.

Our health and lives depend on it.

Sincerely,

Helena Birecki

D9 San Francisco resident

From: [Jeff Weitzel](#)
To: [Major, Erica \(BOS\)](#)
Cc: [Board of Supervisors \(BOS\)](#); [Preston, Dean \(BOS\)](#); [Peskin, Aaron \(BOS\)](#); [Safai, Ahsha \(BOS\)](#); [Ronen, Hillary](#)
Subject: Public Comment Re: BoS File 200701
Date: Monday, October 5, 2020 7:01:19 AM

This message is from outside the City email system. Do not open links or attachments from untrusted sources.

I live in District 9 in San Francisco, and I'm writing to voice my support for a natural gas ban in new buildings in San Francisco. Given the enormous footprint buildings account for in California's climate impact, natural gas has no future in our state or our nation's energy mix, and every new structure erected with gas infrastructure is a building that will have to be retrofitted for electric heating and cooking only a few years into its lifetime

Please refer to the letter of September 18th, sent to the Land Use and Transportation Committee and signed by Earthjustice, the Sierra Club, the SF Climate Emergency Coalition, PODER SF and more than 20 other organizations. I urge the Committee to adopt the changes outlined in that letter and recommend an amended All Electric ordinance to the full Board of Supervisors.

It is important to me that we:

1. Eliminate the feasibility exception to the electric-ready requirement and make fully electric-ready construction a baseline requirement for new construction. We know that the future is electric. Allowing any building to be built that will require massive retrofits in the near future is unacceptable. With full electric readiness, we minimize that retrofit cost.
2. Create a Clean Energy Building Hub through the City and County of San Francisco that provides for the outreach, resources, and education needed to eliminate barriers and maximize opportunity for all-electric new construction to benefit both climate and equity.
3. Expand the ordinance's definition of "mixed-fuel buildings" to include laboratory, industrial, and decorative uses of gas. Gas shouldn't be allowed for upscale decorative uses. It's wrong to harm public health for private enjoyment.
4. Provide additional limitations and transparency in the exemption process to ensure any project found exempt for infeasibility is truly in the public interest. I'm concerned about the news of powerful and connected people being able to get favors from DBI. We need sunshine on the exemption process, and exemptions should only be given in the public interest.
5. Amend section 106A.1.17 to require that the Building Official find "sufficient evidence was submitted to substantiate the infeasibility of an All-Electric Building or Project design without regard to financial, floor-area, or amenity-related loss unless

deemed to be in the public welfare." The housing crisis is real. And we need to find ways of fixing it without sacrificing our children's future. The space taken up by a transformer should not be an acceptable reason for an exemption.

6. Eliminate the blanket exemption for commercial kitchens delaying compliance until 2022. Existing restaurants are not helped by giving builders a pass on making future commercial kitchens all-electric.

Thank you for taking up this important issue and considering the health and safety of our residents and climate.

Sincerely,

Jeff Weitzel

2264A Bryant St, San Francisco, 94110

Breana Wheeler
1119 Stanyan Street
San Francisco, CA
94117

October 2, 2020

Clerk of the Board
Land Use and Transportation Committee
San Francisco Board of Supervisors
1 Dr. Carlton B. Goodlett Place, Room 244
San Francisco, CA 94102

RE: Support for AB112 All-Electric New Construction Regulations

Dear Commissioners,

I am writing to express my full support for AB112, the All-Electric Buildings for New Construction ordinance, introduced for adoption on June 30, 2020 by Supervisor Mandelman. I am a San Francisco resident and a sustainability professional in the real estate and construction industry. I care deeply about our city and all the communities within it.

The Department of the Environment has put forward a solid case for adopting this new ordinance. I agree that this ordinance is critical to:

- Fulfill the city's commitment to combating climate change.
- Strengthen our city's ability to get back to business quickly after an earthquake (as demonstrated by the superior resilience of the electrical grid compared to the natural gas infrastructure, as seen after Hurricanes Sandy and Katrina as well as the fires in Sonoma County in 2017 and 2019)
- Protect human health from the pollutants that cause both poor indoor and outdoor air quality, and address the disproportionate impact on the health of our low-income residents and communities of color from the resulting indoor and outdoor air pollution created by residential natural gas use.
- Reduce the risk of fires and explosions on a day to day basis, as well as in the case of an earthquake.

We should be thoughtful about helping those who see themselves as the "losers" as a result of this change, and seek innovative and meaningful ways to support them. But there is far more to gain by a much broader group of people, and over generations, by adopting these regulations.

Please be forward-thinking enough to take the necessary actions to place help make this ordinance the law in San Francisco.

Very Truly yours,

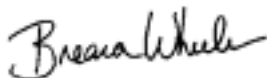

E: breana.wheeler@gmail.com

M: 415-866-9167

Steven Guttman

October 1, 2020

Clerk of the Board
Land Use and Transportation Committee
San Francisco Board of Supervisors
1 Dr. Carlton B. Goodlett Place, Room 244
San Francisco, CA 94102

RE: Support for AB112 All-Electric New Construction Regulations

Dear Committee Members,

I am writing to express my full support for AB112, the All-Electric Buildings for New Construction ordinance, introduced for adoption on June 30, 2020 by Supervisor Mandelman. I am a native San Franciscan, I currently reside in San Francisco, and I am a design professional in the construction industry with personal experience designing all-electric buildings.

The Department of the Environment has put forward a solid case for adopting this new ordinance. I agree that this ordinance is critical to:

- Fulfill the city's commitment to combating climate change.
- Strengthen our city's ability to get back to business quickly after an earthquake (as demonstrated by the superior resilience of the electrical grid compared to the natural gas infrastructure, as seen after Hurricanes Sandy and Katrina as well as the fires in Sonoma County in 2017 and 2019)
- Protect human health from the pollutants that cause both poor indoor and outdoor air quality, and address the disproportionate impact on the health of our low-income residents and communities of color from the resulting indoor and outdoor air pollution created by residential natural gas use.
- Reduce the risk of fires and explosions on a day to day basis, as well as in the case of an earthquake.

We should be thoughtful about helping those who sees themselves as the "losers" as a result of this change, and seek innovative and meaningful ways to support them. But there is far more to gain by a much broader group of people, and over generations, by adopting these regulations.

Please be forward-thinking enough to take the necessary actions to place help make this ordinance the law in San Francisco.

Very Truly yours,



Steven Guttman

d:\personal stuff\documents\z text documents\ab112 letter rev3.docx

359 Vernon Street
San Francisco, CA 94132
(415) 585-8347

From: [Teresa Jan](#)
To: [Major, Erica \(BOS\)](#)
Subject: Support for AB112
Date: Sunday, October 4, 2020 9:50:46 PM
Attachments: [AB112 Support Letter from Teresa Jan- Oct 4, 2020.pdf](#)

This message is from outside the City email system. Do not open links or attachments from untrusted sources.

Hi Erica,
See my support letter for AB 112 attached. Thank you.

Teresa Jan
Senior Associate
AIA, LEED AP, WELL AP

g o u l d e v a n s

tel:
+14158442138
teresa.jan@gouldevans.com

95 Brady Street
San Francisco, CA 94103
www.gouldevans.com

October 04, 2020

Clerk of the Board
Land Use and Transportation Committee
San Francisco Board of Supervisors
1 Dr. Carlton B. Goodlett Place, Room 244
San Francisco, CA 94102

RE: Support for AB112 All-Electric New Construction Regulations

Dear Commissioners,

I am writing to express my full support for AB112, the All-Electric Buildings for New Construction ordinance, introduced for adoption on June 30, 2020 by Supervisor Mandelman.

As a registered architect, I have professional experience designing all-electric buildings for both residential and non-residential buildings. In 2019 fall, I organized and partnered with Riggs Showroom Burlingame, and AEC professionals from Frontier Energy, Berkeley Lawrence Lab and Arup Engineering for a panel discussion regarding induction cooking. The panel discussion event premiered a short documentary film of gas and induction cook off as well as live induction cooking demonstration and reception, demystifying and providing hand on experience of induction cooking. The event was well attended by 70 people and generated many good follow ups conversation and outreach.

To walk the talk, I have replaced my aged gas boiler to heat pump/electrical boiler as well as only cooking with portable induction cooktop, induction wok and instant pot at home – quick and easy, versatile and precise, better air quality and safer for my family and the environment. I truly support AB112 as our quickest pathway to decarbonize and minimize casualty our built environment.

The Department of the Environment has put forward a solid case for adopting this new ordinance. I agree that this ordinance is critical to:

- Fulfil the city's commitment to combating climate change, social equity and environmental justice.
- Strengthen our city's ability to get back to business quickly after an earthquake (as demonstrated by the superior resilience of the electrical grid compared to the natural gas infrastructure, as seen after Hurricanes Sandy and Katrina as well as the fires in Sonoma County in 2017 and 2019)
- Protect human health from the pollutants that cause both poor indoor and outdoor air quality for all, and address the disproportionate impact on the health of our low-income residents and communities of color from the resulting indoor and outdoor air pollution created by residential (and commercial) natural gas use. Children are particularly impacted since their mind and body are still developing.
- Reduce the risk of fires and explosions on a day to day basis, as well as in the case of an earthquake.

We should be thoughtful about helping those who worry about financial burdens resulting of this change, such as plumbers and restaurant owners, and seek innovative and meaningful ways to support them. Education and training programs for plumbers, electricians, contractors, and inspectors for the heat pump technology installation, integration and commissioning are crucial; Rebates and incentive program for both residential and commercial induction and electrical cooking appliances should be made available to cover the more expensive cost until the price of new technology become truly competitive. The hand on equipment try out program (like FTSC) would facilitate the swift change of cooking habits for both professional and home chefs, especially come to understanding that induction wok works just as well as

traditional wok on gas stovetop. Public and private investment today will be far more to gain by a much broader group of people, and over generations, by adopting these regulations.

Covid-19 Pandemic demonstrated us the importance of collective action to ensure public health and illuminate the inequitable/injustice of our built environment. San Francisco is the capital of technology and brilliant minds and that we should continue to be the leader and example of transforming our home to be safer, healthier, and equitable. I appreciate all the forward-thinking efforts to take the necessary actions and help make this ordinance the law in San Francisco.

yours,

Teresa Jan
AIA, LEED AP, WELL AP
Senior Associate
Gould Evans

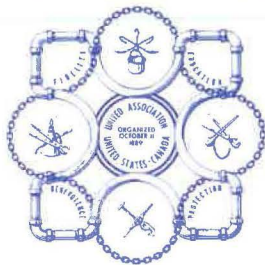

**UNITED ASSOCIATION OF JOURNEYMEN AND APPRENTICES
OF THE PLUMBING AND PIPE FITTING INDUSTRY**

LOCAL UNION NO. 38

1621 MARKET STREET • SAN FRANCISCO, CA 94103

October 1, 2020

Mayor London N. Breed
City Hall, Room 200
1 Dr. Carlton B. Goodlett Place
San Francisco, CA 94102
Email: MayorLondonBreed@sfgov.org

Board of Supervisors
c/o Angela Calvillo, Clerk of the Board of Supervisors
1 Dr. Carlton B. Goodlett Place
City Hall, Room 244
San Francisco, Ca. 94102-4689
Email: Board.of.Supervisors@sfgov.org

Debbie Raphael
Director of the San Francisco Department of the Environment
1455 Market Street, Suite 1200
San Francisco, CA 94103
Email: environment@sfgov.org

RE: File No. 200701 Ordinance amending the Building Code to require new construction to utilize only electric power

Dear Mayor Breed, Board of Supervisors, and Ms. Raphael:

I am writing on behalf of Local 38 to request amendment of the proposal to adopt a local ordinance amending the San Francisco Building and Environment Codes to require new construction to utilize only electric power.

**I. Electrification of Buildings Must Address Impacts on Workers;
Electrification Eliminates an Entire Sector of Skilled Construction Work.**

Without amendment, Local 38 opposes the proposed ordinance banning gas piping and appliances in new construction because it fails to address the significant and immediate loss of good paying, skilled construction jobs that will result from this ban. While the UA and Local 38 support the goal of drastically reducing greenhouse

Steven Guttman

October 1, 2020

Clerk of the Board
Land Use and Transportation Committee
San Francisco Board of Supervisors
1 Dr. Carlton B. Goodlett Place, Room 244
San Francisco, CA 94102

RE: Support for AB112 All-Electric New Construction Regulations

Dear Committee Members,

I am writing to express my full support for AB112, the All-Electric Buildings for New Construction ordinance, introduced for adoption on June 30, 2020 by Supervisor Mandelman. I am a native San Franciscan, I currently reside in San Francisco, and I am a design professional in the construction industry with personal experience designing all-electric buildings.

The Department of the Environment has put forward a solid case for adopting this new ordinance. I agree that this ordinance is critical to:

- Fulfill the city's commitment to combating climate change.
- Strengthen our city's ability to get back to business quickly after an earthquake (as demonstrated by the superior resilience of the electrical grid compared to the natural gas infrastructure, as seen after Hurricanes Sandy and Katrina as well as the fires in Sonoma County in 2017 and 2019)
- Protect human health from the pollutants that cause both poor indoor and outdoor air quality, and address the disproportionate impact on the health of our low-income residents and communities of color from the resulting indoor and outdoor air pollution created by residential natural gas use.
- Reduce the risk of fires and explosions on a day to day basis, as well as in the case of an earthquake.

We should be thoughtful about helping those who sees themselves as the "losers" as a result of this change, and seek innovative and meaningful ways to support them. But there is far more to gain by a much broader group of people, and over generations, by adopting these regulations.

Please be forward-thinking enough to take the necessary actions to place help make this ordinance the law in San Francisco.

Very Truly yours,



Steven Guttman

d:\personal stuff\documents\z text documents\ab112 letter rev3.docx

359 Vernon Street
San Francisco, CA 94132
(415) 585-8347

gas (GHG) emissions, eliminating gas plumbing from all new building construction poses a real and immediate threat to the livelihood of plumbers by eliminating an entire sector of new building construction work without any plan to replace these jobs.

As society takes the necessary policy steps to reducing GHGs, it cannot ignore to the unintended impacts some of these policy decisions have on workers. Where entire job sectors are being eliminated or minimized, we need to ensure steps are in place to provide the affected workers with a “just transition” to replacement work. And we need to ensure that those steps are taken concurrently because we know from experience that just transition never happens after the fact. Too often, “just transition” is just an empty promise.

Local 38 understands that the Board and many members of the community are impatient to adopt an electrification ordinance. But it cannot be ignored that this ordinance will create immediate significant job losses for Local 38’s members and others. An action with such significant job loss impacts should not be rushed through without ensuring that these job losses will be mitigated. Local 38 urges the committee to have staff sit down with Local 38 to ensure that a path for just transition is incorporated into this ordinance before it leaves this committee.

II. A Path for Just Transition Exists that Aligns with the City’s Energy and Water Efficiency Goals

The additional electrical work created by a mandatory electrification ordinance for new construction will be just a small fraction of the work hours lost by eliminating gas plumbing in buildings. Moreover, the minimal amount of additional work that would be created is performed by an entirely different craft and will not create substitute employment opportunities for the skilled plumbers whose livelihood is directly impacted by this ordinance. Nor can this work be replaced by “outreach, education, and support for workforce training” as recommended by the San Francisco Department of the Environment.

However, there is a path to mitigating the ordinance’s elimination of an entire sector of skilled plumbing new building construction work, while at the same time furthering San Francisco’s goals to reduce both energy and water use. In order to provide a just transition to plumbers that will no longer be employed installing gas piping and appliances in new building construction, the electrification ordinance should be tied to additional requirements to expand the use of graywater, rainwater and/or recycled water, with a particular focus on the use of alternative water sources within buildings for non-potable applications. Such a requirement would provide those workers most directly impacted by this ordinance with with new replacement work that will further benefit San Francisco by also providing substantial energy and water savings.

Specifically, the following requirements should be concurrently adopted by San Francisco:

A. New construction projects subject to the electrification ordinance should be required to pre-plumb buildings for indoor use of alternative water sources – either recycled water or on-site treated graywater/rainwater depending on availability.

B. New construction projects subject to the electrification ordinance should be required to install solar hot water systems or graywater heat recovery systems that preheat cold water with the heat from wastewater.

C. Buildings subject to electrification requirements should have the option to instead use renewable gas where available, including approval of pilot programs.

D. Certification – Require the use of a “skilled and trained workforce as defined in Public Resources Code Section 2600 for installation of graywater/rainwater systems over a certain size threshold, plumbing for indoor use of recycled water/graywater/rainwater, and onsite treatment systems.

III. Just-Transition Alternative Water Source Requirements Must Be Adopted Concurrently with the Effective Date of the New Construction Electrification Requirements

Local 38 strongly urges the Board to ensure that mandatory electrification requirements adopted for new construction are adopted concurrently with just-transition alternative water requirements. Experience shows that just transition solutions must be addressed concurrently with the policy changes that raise the need for a just transition. The proposed electrification ordinance for new construction will result in immediate and drastic impacts on the livelihood of plumbers who currently install gas infrastructure in buildings. Replacement work needs to be made available concurrently with the elimination of this existing work.

For that reason, the proposed electrification ordinance should be adopted with the following additional requirements incorporated into the ordinance: (1) staff shall immediately commence proceedings to develop and adopt mandatory dual plumbing and other alternative water requirements; (2) staff shall propose an ordinance with mandatory dual plumbing and other alternative water requirements for adoption no later than July 1, 2021; (3) the effective date of the proposed electrification ordinance for new construction shall be 30 days after adoption of an ordinance with mandatory dual plumbing and other alternative water requirements.

IV. Conclusion

Local 38 requests an opportunity to meet with staff prior to the next Committee hearing in order to work out a path to address this critical issue. The job losses that will result from this proposed ordinance are real and will be immediate.

Sincerely

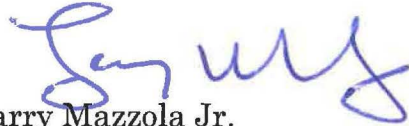
A handwritten signature in blue ink, appearing to read "Larry Mazzola Jr.", written in a cursive style.

Larry Mazzola Jr.
Bus. Mgr. & Fin.Secty-Treas.
UA Plumbers & Pipefitters Local 38

From: [Sonia Van Braden](#)
To: [Major, Erica \(BOS\)](#); [Board of Supervisors, \(BOS\)](#); [Preston, Dean \(BOS\)](#); [Peskin, Aaron \(BOS\)](#); [Safai, Ahsha \(BOS\)](#); [MandelmanStaff, \(BOS\)](#); [Ronen, Hillary](#)
Subject: Public Comment Re: BoS File 200701 (Item 1 of 9/21 Land Use)
Date: Wednesday, September 23, 2020 9:40:44 PM

This message is from outside the City email system. Do not open links or attachments from untrusted sources.

Land Use Committee, Board of Supervisors, and Sup. Ronen,

I'm a resident of San Francisco writing to strongly support prohibiting gas in new construction. The methane leaks, air pollution, and explosion dangers of natural gas are no longer necessary for the functioning of our homes and businesses. San Francisco can lead the state and the country in building a better future.

In addition to recommending the ordinance, I would also like to ask the Commission to recommend the changes to the ordinance as laid out by Earthjustice, the Sierra Club, the San Francisco Climate Emergency Coalition, and other local groups in their letter to the Commission and Board.

It is important to me that we:

1. Eliminate the feasibility exception to the electric-ready requirement and make fully electric-ready construction a baseline requirement for new construction. We know that the future is electric. Allowing any building to be built that will require massive retrofits in the near future is unacceptable. With full electric readiness, we minimize that retrofit cost.
2. Create a Clean Energy Building Hub through the City and County of San Francisco that provides for the outreach, resources, and education needed to eliminate barriers and maximize opportunity for all-electric new construction to benefit both climate and equity.
3. Expand the ordinance's definition of "mixed-fuel buildings" to include laboratory, industrial, and decorative uses of gas. Gas shouldn't be allowed for upscale decorative uses. It's wrong to harm public health for private enjoyment.
4. Provide additional limitations and transparency in the exemption process to ensure any project found exempt for infeasibility is truly in the public interest. I'm concerned about the news of powerful and connected people being able to get favors from DBI. We need sunshine on the exemption process, and exemptions should only be given in the public interest.
5. Amend section 106A.1.17 to require that the Building Official find "sufficient evidence was submitted to substantiate the infeasibility of an All-Electric Building or Project design without regard to financial, floor-area, or amenity-related loss unless deemed to be in the public welfare." The housing crisis is real. And we need to find ways of fixing it without sacrificing our children's future. The space taken up by a transformer should not be an acceptable reason for

an exemption.

6. Eliminate the blanket exemption for commercial kitchens delaying compliance until 2022. Existing restaurants are not helped by giving builders a pass on making future commercial kitchens all-electric.

Thank you for taking up this important issue and considering the health and safety of our residents and climate.

Sonia Van Braden
svanbraden@gmail.com
608 Andover St
San Francisco, California 94110

9/18/2020

Land Use and Transportation Committee
San Francisco Board of Supervisors
1 Dr. Carlton B. Goodlett Place
City Hall, Room 244
San Francisco, CA 94102

Dear Supervisors Peskin, Safai, and Preston,

On behalf of SPUR, I am writing to express support for the proposed ordinance amending the building code mandating all new construction be all-electric (File #200701). This ordinance would require new construction to use only electric power, with a delayed effective date for restaurants and an exception for buildings where it is physically or technically infeasible.

To meet California's climate goals of reducing greenhouse gas emissions by 40 percent by 2030 and 80 percent by 2050, the state needs to move expediently to electrify buildings, while decarbonizing the electrical grid. The state is making good progress toward decarbonizing its energy grid, but is falling behind in efforts to electrify buildings. Bay Area Air Quality Management District projected in their 2017 Clean Air Plan that for the region to meet its climate goals, 100 percent of new residential construction needs to be zero net energy by 2020, with new commercial construction following suit by 2030. Clearly the Bay Area has failed to meet its goal of electrifying residential buildings by 2020. We need to act urgently to make up for lost time.

In our report, [Fossil Free Bay Area](#), SPUR identified electrifying buildings as one of nine key strategies for the Bay Area to achieve a zero-carbon future. Thirty-three cities in California have already passed reach codes to reduce buildings' reliance on natural gas. San Francisco is one of those, having banned natural gas appliances in its municipal buildings earlier this year. San Francisco is in position to lead again on this issue by demonstrating that all-electric residential buildings are economically feasible to build and attractive to consumers.

However, given San Francisco's need to address its housing shortfall, the city should carefully monitor the impact of this ordinance to ensure that it does not discourage construction of new housing units. Of particular concern are master-planned projects with a signed Development Agreement and natural gas mains already in place before this ordinance goes into effect. SPUR suggests to explore either grandfathering in certain of the buildings in these projects in to allow construction of mixed-fuel buildings, or to find other ways of helping the developers recover the cost of installing the gas mains. Two projects in San Francisco, Treasure Island and Pier 70, would fit in this special circumstance. SPUR urges the author of the bill to work with the affected parties to address their concerns.

Sincerely,



Laura Feinstein, Ph.D.
Sustainability and Resilience Policy Director

From: [Sven Thesen](#)
To: [Peskin, Aaron \(BOS\)](#); [Hepner, Lee \(BOS\)](#); [Safai, Ahsha \(BOS\)](#); [Sandoval, Suhagey \(BOS\)](#); [Preston, Dean \(BOS\)](#); [Smeallie, Kyle \(BOS\)](#); [MandelmanStaff, \[BOS\]](#); [Bintliff, Jacob \(BOS\)](#); [Raphael, Deborah \(ENV\)](#); [Board of Supervisors, \(BOS\)](#); [Major, Erica \(BOS\)](#)
Cc: dktahara@gmail.com; [Marc Geller](#); [James Tuleya](#); [John Brown](#); [Craig Gordon](#)
Subject: Invitation, All Electric Home Virtual Tour, San Francisco Supervisors & All-Electric New Construction Ordinance (File 200701)
Date: Monday, September 21, 2020 9:16:56 AM
Attachments: [ProjectGreenHome Booklet 2016-digital Small.pdf](#)

This message is from outside the City email system. Do not open links or attachments from untrusted sources.

Gentle San Francisco Supervisors,

To aid you in your deliberations regarding electrification Reach Codes, you are individually and collectively invited to virtually tour our all electric home today, Monday from 10a to 4p. Pick your time and email/ call me 415-225-7645*. Understanding the short notice, we are happy to schedule at other times and also invite staff, significant others and interested parties. The honor of the tour is ours.

Our ~2300ft² home has been all electric** since 2011 when it was constructed. In summary, having lived with gas in prior homes, my wife and I have determined that our standard of living/ quality of life is simply better with the all electric home. It's safer, more convenient and cheaper than the electric / gas home.

As background, for our strong support for electrification, my wife, the physician, and I, the chemical engineer, (& as parents), are from a micro perspective, particularly concerned about indoor ambient air quality and the dangers from burns and fires associated with gas stoves. On the macro side, we are equally concerned about the overall carbon footprint of our society and the associated impacts including sea level rise, droughts, fires, floods, species (including humans) migration/ loss and more.

I have attached a booklet*** on the home; the website is ProjectGreenHome.org and we were featured in Bay Area Bountiful in 2019, <https://www.youtube.com/watch?v=IUUnYjs9JsA> the story starts at 00:59

Best,
Sven Thesen & Kate Kramer, MD

*If these dates/ times are not convenient, we can schedule for later, again, feel free to ping me. We have had over 4,000 people through the house since 2009 including CEC commissioners, politicians of all stripes, staff from CARB, CPUC & CEC, the public and even scouts and Sunday school classes.

**Natural gas history: The home was designed in 2008/9 and built 2010/11, when heat pumps, etc. were in the "toddler" adoption stage in the United States. We were concerned that the induction stove, the heat pump, the condensing dryer, all or some, would not work so we plumbed for gas & had a gas connection. Turns out that it does all work and so we had the utility "cut" the gas line in 2013 (& stopped paying the monthly connection fee). Had we not installed gas from the beginning, we would have likely saved on the order of \$10k in construction and permitting costs.

*** Sorry, it needs updating to the present. My kids are so tall now!

--

Sven Thesen, 415-225-7645

EV Consultant & Founder, ProjectGreenHome.org and BeniSolSolar.com; Wonder Junkie

Electric Cars are Cheaper than Cell Phones! See:

<http://www.projectgreenhome.org/articles.html>

Project Green Home



*The Beyond LEED Platinum,
Zero Net Energy,
Passive House*

ProjectGreenHome.org

Definition Purpose Features

314 Stanford Ave
Palo Alto CA

When we started thinking about building a home from “scratch”, we saw an opportunity to examine the environmental impact from the ground up, and what we could do to minimize the home’s “total lifetime carbon cost.” Within this context, we decided to put the theories and green rating systems (Leadership in Energy & Environmental Design, Zero Net Energy and Passive House) into practice. The result is this beautiful, functional, comfortable, ultra efficient, low carbon house. We hope that others may be inspired, and in their turn, move the efficiency bar even further forward.

Of course, nothing exists in a vacuum. Our work on this house has involved partner- contractors and architects, but also our friends, neighbors, high school and university students, and others. It is more than just our home; it has brought us closer to the community around us.

Wake up America! In our opinion, global warming is and will be the single most important issue for the current and next several generations. As shown below, the earth's atmospheric carbon dioxide (CO₂) concentration has increased by almost 130 ppm since ~1850 and over 25 ppm just in the last 10 years! We have to do something!

Having now lived here for over two years, Project Green Home proves that we can address global warming and have a beautiful, comfortable, functional and sustainable home.

-Sven Thesen and Kate Kramer

Date / Activity	<1850 pre-industrial	2006 looking at homes	2008 bought property	2010 began construction	2012 moved in	2016 present
CO ₂ (ppm)	280	380	384	388	392	408



October 2010, daughters Sophia and Genevieve indicate their position on Proposition 23. Primarily funded by out-of-state oil companies, Prop 23 would have rolled back California's landmark Global Warming Solutions Act of 2006 requiring the State to reduce greenhouse gas emissions to 1990 levels by 2020 and a 80% reduction over 1990 emissions by 2050. The first fundraiser held at the then unfinished home was against Proposition 23.

Table of Contents

1. Purpose, Definitions & Background, Living Room	7
1.1 Purpose, Living Room.....	7
1.2 Leadership in Energy & Environmental Design, Living Room	7
1.3 Zero Net Energy Building (ZNE), Living Room	8
1.4 Passive House, Living Room	8
1.5 Home Background, Living Room.....	9
2 Features	10
2.1 Design	10
2.1.1 Airtight Construction, Sophia’s Bedroom	10
2.1.2 Passive Solar Design, Sophia’s Bedroom.....	11
2.1.3 Filtered Fresh Air & Heat Recovery, Sophia’s Bedroom	12
2.1.4 2x8 Studs at 24” Spacing, Genevieve’s Bedroom	13
2.1.5 Air Admittance Valves (AAVs), Children’s Bathroom	14
2.1.6 White Metal Roof, Upstairs Open Space	14
2.1.7 Skylight Passive Ventilation, Upstairs Open Space	15
2.1.8 Active Ventilation, Ceiling Fan, Upstairs Open Space.....	15
2.1.9 Daikin Altherma heat pump water heater, Upstairs Utility Closet.....	16
2.1.10 Radiant Floor Heating, Living Room.....	16
2.1.11 Gas Fire Place, Living Room.....	17
2.1.12 Post & Beam Interior Designed for Remodeling, Library.....	17
2.1.13 Aging-In-Place or Extended Family, Study.....	18
2.2 Insulation	18
2.2.1 Insulation Rating System/ Standard, Genevieve’s Room	18
2.2.2 Wall and Ceiling Insulation, Genevieve’s Room	18
2.2.3 Unvented Roof (Full Cavity insulation), Genevieve’s Room.....	19
2.2.4 Insulated Header, Genevieve’s Room	20
2.2.5 Floor Insulation, Ground Guestroom.....	20
2.3 Electrical Energy	21
2.3.1 Electricity & Electrical Wiring, Sophia’s Room.....	21
2.3.2 Photovoltaic System, Master Bedroom.....	21
2.3.3 CAT6/Data Wiring, Desk Nook.....	22
2.3.4 Energy Monitoring System, Laundry Room.....	23
2.4 Illumination	24
2.4.1 Daylighting, Study.....	24
2.4.2 Electric Lighting, Guest Bedrooms.....	24
2.5 Interesting Materials	25
2.5.1 Quality Windows, Upstairs Guest Bedroom.....	25
2.5.2 Concrete Slab, Dining Area.....	26
2.5.3 FSC lumber, Dining Area	26
2.5.4 The Tree Post, Dining Area	27
2.5.5 Low-VOC Materials, Master Bedroom	27
2.5.6 Hardie Plank, Carport.....	27
2.5.7 Living/ Green Roof, Upstairs Open Space – Lost to Photovoltaics	27
2.6 Reconstructed and Salvaged Materials	28
2.6.1 Golden Bear Recycled Stone Tile, Living Room	28
2.6.2 Salvaged beams, Living Room.....	28
2.6.3 Windows Upstairs Foyer, Upstairs Guest Bedroom	28
2.6.4 Sliding Interior Doors, Living Room.....	29

2.6.5	Wooden Flooring, Second Floor Hall	29
2.6.6	Recovered Redwood Siding, Carport.....	30
2.6.7	Exterior Exposed Wood Siding, Living Room Porch.....	30
2.6.8	Front Fence & Vegetable Bed-Reused Material, Carport.....	30
2.7	Water and Associated Energy Use	31
2.7.1	Recirculating Hot Water Line, Master Bathroom.....	31
2.7.2	Drainwater heat recovery (Powerpipe unit) Downstairs Bathroom	32
2.7.3	Toilets, Eco Flush, Childrens & Master Bathrooms.....	32
2.7.4	Toilets, Caroma Smart, Downstairs Bathroom	33
2.7.5	Graywater, Showers, Sinks, Laundry and 1% Urine, Laundry Room	33
2.7.6	Graywater, Kitchen Sink, Kitchen.....	35
2.7.7	Low Flow Shower and Sink Faucets, Downstairs Bathroom	36
2.7.8	Rain Water Collection, Backyard.....	36
2.7.9	Permeable Concrete, Front Entrance Porch	37
2.8	Kitchen and Appliances.....	37
2.8.1	Inductive Range/ Stove, Kitchen	37
2.8.2	Refrigerator, Kitchen	38
2.8.3	Appliances, Sink Garbage Disposal, Kitchen	38
2.8.4	Kitchen Countertops, Kitchen	39
2.8.5	Kitchen Cabinetry, Kitchen.....	40
2.8.6	Clothes Washer, Dryer, and Dishwasher. Laundry Room	40
3	Landscaping, Work in Progress	40
3.1	Cardboard Under the Oak/ Oxalis, Backyard.....	41
3.2	Chickens, Bees and other Pets	41
3.3	Fruit Trees	41
4	Green Jobs, Master Bedroom	42
5	Deconstruction, Master Bedroom	42
6	Transportation	44
6.1	Plug In Hybrid Electric Vehicle, Ground Floor Foyer	44
6.2	Electric Vehicles & Charging, Front Porch.....	45
6.3	Curbside Side Electric Vehicle Charging Stations, Front Yard	46
7	Mistakes Made Along the Way, Downstairs Guest Room.....	47
7.1	Polyvinyl Chloride (PVC)	47
7.2	Screening Fence West Side Between the Neighbors	48
8	Regulatory Barriers, Upstairs Open Space	48
8.1	White Roof	48
8.2	House Positioning	49
8.3	Garage/ Carport Requirements	49
8.4	Graywater infused with 1% Urine.....	49
9	Partners, Study, Upstairs Guest Bedroom.....	49
9.1	Lawrence Berkeley National Laboratory (LBNL).....	49
9.2	Acterra.....	50
9.3	Bay Area Climate Collaborative (BACC)	50
9.4	UC Berkeley	50
10	Providers	50
10.1	Architect - Arkin Tilt.....	50

10.2	Construction Project Manager/ Builder/ Passive House Consultant	51
10.3	Plumber - Moomau	51
10.4	Roof - Custom Copper and Sheet Metal Roofing	51
10.5	HVAC - Bayside Mechanical	51
10.6	Insulation - Tri-County Insulation	52
10.7	Stucco - Green Wall Tech	52
10.8	Student Booklet Editors	52
11	In Memoriam	53
11.1	Dr. Edgar Wayburn, M.D.	53
11.2	Dr. Stephen H. Schneider	54

1. Purpose, Definitions & Background, Living Room

The goals of our project, and the background that goes with it.

1.1 Purpose, Living Room

What is the purpose of the home?

Project Green Home (PGH), located in Palo Alto, California, less than three blocks from Stanford University campus, is a single family dwelling of approximately 2,400 square feet completed in June 2011. The home:

- Meets (and exceeds) the State's residential 2020 zero net energy requirements now;
- Meets the Passive House standard, surpassing LEED platinum and California's Title-24;
- Integrates both cutting edge and available energy efficiency technologies;
- Incorporates the best, cheapest, longest-lasting, safest, most aesthetically pleasing product and materials available;
- Serves as a model and showcase for green/energy efficient building technologies;
- Meets California's Assembly Bill 32 requirement for 80% greenhouse gas emission reduction by 2050, right now;
- Created more "green jobs" in the construction industry versus incremental additional jobs in the fossil fuel industry.

As a working model of the possible, Project Green Home hopes to serve as a real-life replicable example, creating a virtuous circle of similar sustainable housing. As such we welcome the involvement of the community and, in particular, students in evaluating the home against the above design parameters, and likewise media coverage to publicize the possibilities.

1.2 Leadership in Energy & Environmental Design, Living Room

LEED is a rating scale for "green" homes; we aim to well surpass their Platinum rating

Leadership in Energy & Environmental Design (LEED) is an internationally recognized green building certification/numerical rating system, providing third-party verification that a building or community was designed and built using strategies intended to improve performance in

metrics such as energy savings, water efficiency, CO₂ emissions reduction, improved indoor environmental quality, and stewardship of resources and sensitivity to their impacts. To verify that the house is achieving the highest standards of green and sustainable design the project received the highest ranking, Platinum certification in the LEED for Homes rating system. This system covers every aspect of home construction, from integrated design; the use of materials, energy and water; the building's interaction with the surrounding community; and the quality and health of the indoor environment.



USGBC

For a house our size and our climate, the difference between each of the LEED rankings (Certified, Silver, Gold and Platinum) as noted in the table below, is 15 points. We call our

house “Beyond Platinum LEED,” as PGH received a LEED score of 109 which is 22 points above Platinum and 46% greater than the delta between each of the rankings.

LEED Potential Ratings for Project Green Home:

<i>Certified</i>	<i>Silver</i>	<i>Gold</i>	<i>Platinum</i>	<i>PGH</i>
42	57	72	87	109

The LEED Certification and backup documentation is found in Appendix 1

1.3 Zero Net Energy Building (ZNE), Living Room

A Zero Net Energy Building generates as much energy, on-site, as it uses.

In California, ZNE is defined as the amount of energy provided by on-site renewable energy sources is equal to the amount of energy used by the building. In essence, this means that the amount of externally generated electricity, natural gas or other energy stock used at the home must be equal to the energy generated by the home. This will be the 2020 standard for all new California residential construction. Depending on the location of the home, this can be accomplished by installing and operating photovoltaic (PV) systems (most common) but wind generation systems, small-scale hydropower and other on-site renewables are also options.

To meet the state’s ZNE goals, we installed a 5.9kW photovoltaic (PV) system to self-generate our electricity. This not only covers the annual house energy use but also 8,000 miles (2,000kWh) of electric car use.

The ZNE Certification Documentation is found in Appendix 2

1.4 Passive House, Living Room

Careful construction regulates the temperature of the house naturally, to save energy.

Passive House (***Passivhaus*** in German) refers to the rigorous, voluntary, *Passivhaus* standard for energy efficiency in buildings. It results in ultra-low energy buildings that require little energy for space heating or cooling. Passive design is not the attachment or supplement of architectural design, but an integrated design process with the architectural design. In the United States, a house built to the Passive House standard results in a building that requires space heating energy of 1 BTU per square foot per heating degree day, compared with about 5 to 15 BTUs per square foot per heating degree day for a similar building built to meet the California 2003 Model Energy Efficiency Code. This is between 75-95% less energy for space heating and cooling than current new buildings that meet today's US energy efficiency codes.



At present, essentially three components are needed to meet the Passive House standards: First, minimizing heat loss via insulation and building an airtight structure. Second, the

home uses sunlight as its primary heat source in the winter. Third, in winter the heat in the air stream exiting the building is used to heat the incoming fresh air and vice versa in the summer time.

To be certified as a Passive House, there are three quantifiable standards that need to be met along with the results from Project Green Home (PGH) testing.

	Passive House requirement	Project Green Home result
Annual space heating or cooling demand (site energy)	≤ 4.75 kBTU/sq. ft. (≤ 15 kWh/m ²)	3.94 kBTU/sq.ft. heating 0 kBTU/sq.ft. cooling
Annual total energy demand (source energy)	≤ 38.0 kBTU/sq.ft. (≤ 120 kWh/m ²)	26.6 kBTU/sq.ft.
Air tightness	0.60 ACH ₅₀	0.55 ACH ₅₀

As a result, this objective has been met and likewise brings all the benefits of a Passive House. The Passive House Certification Documentation is found in Appendix 3

1.5 Home Background, Living Room

Who we and the team are and the vision

Start with a family in Palo Alto desiring to change the world for the better with a focus on climate change and energy/water use. Add Arkin Tilt Architects and Josh Moore, our Project Manager, and a common vision is born. Combine this vision with a 7,500 square foot lot in Palo Alto, with a very small termite-ridden house constructed in approximately 1918. Deconstruct this structure (simultaneously recovering all the useable materials) and build a house that meets the above design parameters with the features detailed in Section 2.

2 Features

2.1 Design

2.1.1 Airtight Construction, Sophia's Bedroom

Air tightness testing

There are three components to the Passive House standard. The first is that the house should be airtight and well insulated, so that heat is not transferred through the building membrane. Our walls were tested using an infrared camera, to show where air was seeping in. On the left is a picture taken to demonstrate the use of the camera to show heat. The picture on the right shows a plume of cold air, coming in around the edges of a beam, which (intentionally) punctures the building exterior membrane. This evaluation procedure was the brilliant idea of Josh Moore our Project Manager. Insulation is covered in section 2.2 as there are so many different insulation types used in the house.

The house is essentially a box. To make the structure airtight, the builder had to focus on three primary areas: Where the ground floor wall meets the slab, all window and door openings, and along the roof edge—where numerous rafter tails poke through the air-tight envelope had to be sealed along every edge.

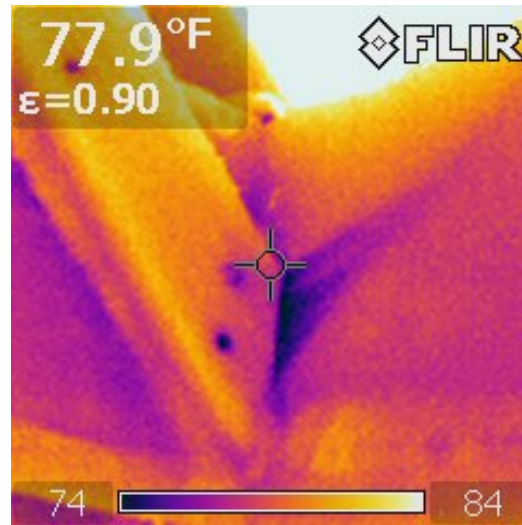
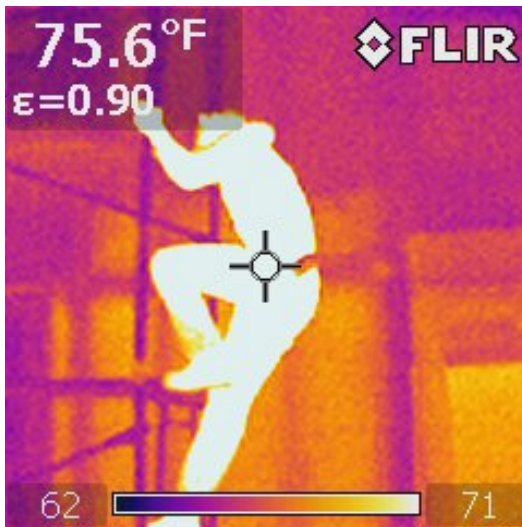

2.1.2 Passive Solar Design, Sophia's Bedroom

Using sunlight to provide ~60% of the heating requirements.

The second component of the Passive House standard is that it uses sunlight as its primary heater in the winter. Most of the windows face south, and the main living spaces are on the south side of the house. Bathrooms, storage, and staircase-parts of the house where less time is spent-are generally located on the north side. Solar heat is estimated to provide 60% of the annual space heating needs, and heat from occupants and appliances inside the house provides another ~15%, according to a simulation in the Passive House Planning Package (PHPP) software used. In addition to the relative inexpensiveness and reduced energy consumption, solar heating inherently does not create greenhouse gases, which also helps to reduce the effects of global warming.

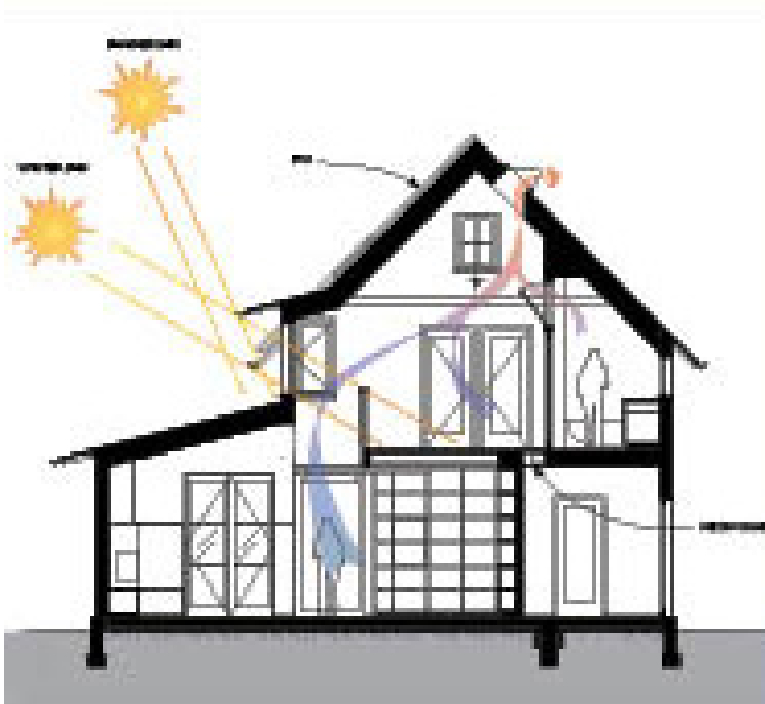

In passive solar heating, warm collected by certain areas of the house is circulated throughout the rooms to generate heating. Usually, large hard surfaces, such as a wall or floor that has been darkened, will absorb sunlight in the form of heat. In our case, the dark concrete floor is the home's primary thermal mass. This stores and gradually releases the heat through conduction, convection, and radiation processes. The overall architecture of the building, as well as the climate and location, also influence the overall ease and success of heat flow.

Outdoor living spaces are integrated on the south side of the house where they connect directly to the main rooms. These outdoor spaces tend to be comfortable for most of the year, shaded by trellises.

It's important to note that the heating (and cooling) needs were based on a computer model. After more than two years of living in the home, we find that overall it is quite comfortable.

2.1.3 Filtered Fresh Air & Heat Recovery, Sophia's Bedroom

Air is recirculated, so that it stays fresh with closed windows in cold months.

The third Passive House component is ensuring a solid supply of fresh air while still meeting the energy efficiency requirements. Here, the house gets fresh air on-demand from a filtered ventilation system located in the attic. Specifically, the heat-recovery ventilation (HRV) equipment pulls a continuous exhaust of stale air from the bathrooms and kitchen, and “harvests” the heat before expelling the air to the outdoors. Simultaneously, outside air is filtered and absorbs heat from the exhaust air via a waffle-grid heat exchanger before being distributed to bedrooms and living rooms. The incoming and outgoing air streams never mix.

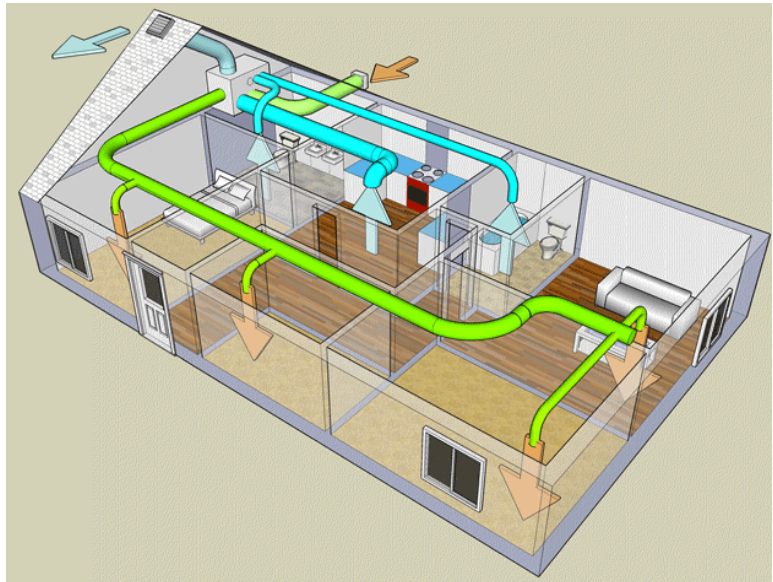

In addition to the energy recovery, the HRV also filters the air. Minimum Efficiency Reporting Value (MERV) is a rating system for air filters. The HRV uses a MERV 9 filter, which is suitable for hospital laboratories and filters $\geq 90\%$ of particulates from the air. The volume is relatively low (80-150 cubic feet per minute), so small ductwork is used (4-6” round, rigid metal). Most of the ductwork is in a chase between floors. Despite the energy needed to run the fan, the HRV creates a net energy savings for the house, and superior indoor air quality.

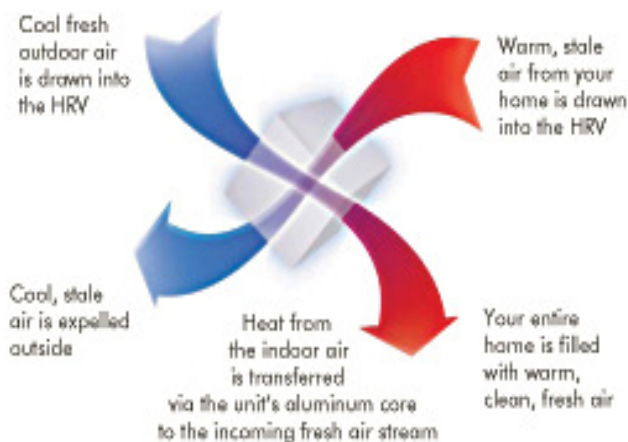

After two years of operation, we find that we should have used larger diameter pipes. This would have reduced the noise and ongoing energy use by the fan. While we have not measured the noise level in the house, we do notice the “white-noise” caused by the system. In actuality, the HRV may or may not be noisy, in that the house is extremely well insulated and sealed which limits outside noise and may make low-level noise more noticeable.

In addition, since the installation of the unit, we have found similar units that are capable of bypassing the heat-exchanger. This is important as, in our Northern California climate, we have hot days and cool nights. In the summer, should we forget to close the windows in the morning (or those in the upper floor), which causes the upstairs to get hot by the end of the

day, the feature to simultaneously quickly pull hot air out of the home and dump cool air in would have been beneficial.

If you are considering such a system, please do contact Sven Thesen for more information regarding a whole host of issues that could have been avoided.

Venmar EKO 1.5, VenMar.ca , installed by Bayside Mechanical, BaysideMech.com

2.1.42x8 Studs at 24" Spacing, Genevieve's Bedroom

Optimizing structural members limits thermal bridging and saves trees.

Advanced Framing or Optimum Value Engineered (OVE) framing is a system that uses wood only where it is necessary structurally. American builders trying to conserve limited resources in the past centuries used a similar framing system. Today, OVE framing typically uses 2x6 studs (5-1/2" thick) at 24" spacing, with less superfluous wood around windows and doors, and at the top and bottom of walls.



Since wood conducts heat much faster than insulation, reducing wood in the walls saves heating and cooling energy. In this house, 2x8 studs (7-1/4") are "balloon framed" over two stories, running from slab to roof, to reduce joints and connections at the intermediate floor. This also makes the house stronger against wind and earthquakes. We are looking for a student to determine if the 2x8 wood use 1) Reduces overall lumber use and 2) Given that a 2x8 requires a larger tree

than a 2x6 (or 2x4), it is the appropriate ecological choice.

Do note that framing with this system takes significantly more detailed drawings and more coordination between builder, architect, and structural engineer. Most builder-architect-engineer teams have never framed this way, and the learning curve is steep and expensive due to the additional time required "to get it right." In our case, our first builder charged an additional \$5,000 for this framing style. However, it is not clear if the first builder saved any monies in reduced material costs

2.1.5 Air Admittance Valves (AAVs), Children's Bathroom

Reduces need for membrane punctures and plumbing piping.



An AAV is a durable, one-way air valve, the size of a large vitamin bottle. It takes the place of a traditional plumbing vent through the roof. The purpose of both the traditional vent and the AAV is to admit relief air into the plumbing system when water is draining, in order to prevent a vacuum in the pipes that would suck water out of the P-traps under faucets. Typical houses have many vents breaking the integrity of the roof, acting as thermal bridges, and circulating outdoor air within the walls. This house has one such vent--the rest are AAVs. AAVs require less plumbing material and labor, and less roof work than conventional vents. When they are enclosed in a wall, AAVs require an access panel for inspection. At present, Palo Alto does not allow AAVs. To waive the prescriptive building code and allow the AAVs, the design team had to submit a formal request including significant documentation to the City of Palo Alto. The request was approved. Full Palo Alto approval documentation is located on ProjectGreenHome.org/features Sure-Vent, Oatey.com

2.1.6 White Metal Roof, Upstairs Open Space

Light colored roof reflects more solar heat, instead of absorbing it.

A "White Roof" is not necessarily white, but is a light color so that it reflects more sunlight, keeping the house cool, and reflecting more light into space. A dark colored roof absorbs more light, and converts it to heat energy. For example, a roof that is true black heats up by 90 degrees Fahrenheit in direct sunlight, while a true white roof heats up by only 14.6 degrees. This light absorbed by a dark colored roof is transferred into heat, and contributes directly to global warming. The light-colored roof also decreases the temperature inside of the building, which reduces energy use associated with cooling the building. However, there is incremental increased energy use in the winter compared to a darker roof.



The Palo Alto Planning Department was concerned about the aesthetic effect of glare on our neighborhood, so we are using a light grey, metallic color that is almost as reflective. Our roof's reflectivity is 58%, while the white option we had available is 63.3%. Because our roof insulation is so thick, the grey roof will have minimal impacts on heating the house in the summer time, and should save a small amount of energy on heating in the winter. The only drawback of the grey roof (versus the white roof) is from a climate perspective: over the course of a year a little more heat is absorbed from sunlight, and will be released

into the air outside the house.

Note, white roofs are speculated to be effective only in warmer climates. Research is currently being conducted to determine if white roofs can save energy in all kinds of climates instead of simply warmer areas such as Palo Alto. For example, it may make sense for a roof to be reflective in the warmer seasons and then darker in the colder months.

In addition to the above, the metal roof was selected over a conventional tile or asphalt shingle tile roof based on a number of factors including aesthetics, (what is understood to be) low embodied energy, long lifetime and ease of recyclability. Asphalt and tile roofs have a sun reflectance of 25%-35%, which is significantly lower than that of metal, which has a 60-70% reflectance. As discussed above, higher reflectance absorbs less sunlight and heat energy, which will decrease the amount of heat energy present to increase the surface temperature of the Earth. In addition, our metal roof has a 40+ year warranty versus asphalt shingles, which are on the order of fifteen to twenty. Asphalt roofing is also non-recyclable, which further increases the associated embodied pollution and waste. Though the upfront cost of asphalt shingles tend to be cheaper, in the long run, we believe metal roofs are more effective and energy efficient. ccsmr.com

2.1.7 Skylight Passive Ventilation, Upstairs Open Space

Open skylights create a thermal stack pulling cold air up from the ground floor.

Three electrically-operated skylights near the ridge of the roof are located to passively ventilate the house. Air moves freely past the upstairs mezzanine balcony/ open space and stairwell, and the height difference of 20+ feet above the ground slab ensures a strong stack effect, or updraft created by the buoyancy of warm air released from a high opening. Because the house does not have a “smart” heating and cooling system, we leave the skylights open in the summer and then close them once we initiate the radiant floor heating system. Without measurements, it is difficult to determine the efficacy of the skylights..



2.1.8 Active Ventilation, Ceiling Fan, Upstairs Open Space

Ceiling fan assists in moving warm air back down in winter & moving warm air out of house in summer &.

The mezzanine/ open space ceiling fan assists in moving warm air back to the inhabited spaces during winter. In summer, turning the fan in the reverse helps move warm air out the skylights. The switch to operate the fan is a manual switch and it is not clear if the unit can communicate to a remote controller or better “smart” heating and cooling system. Because of the manual operation, to date, we have not used the fan (to assist with either cooling or heating) so its efficacy has not been determined.

2.1.9 Daikin Altherma heat pump water heater, Upstairs Utility Closet

Heat from the air outside, with technology much like a refrigerator, is more energy efficient.



This electric water heater transfers heat from the outside air into a water storage tank using refrigerant in a vapor-compression cycle, like an air-conditioner in reverse. The so-called “air-source heat pump” creates 3-4 times more heat from the same electricity as a standard electric water heater. The efficiency is comparable to a geothermal heat pump in this climate, but involves no expensive boring or excavation. In essence, the unit harvests and concentrates outside energy – for every one unit of energy we put into the unit, we get 3-4 units of heat out.

The Altherma costs more than a conventional water heater, but for a zero net energy project, the Altherma costs less upfront to save electricity than the photovoltaic panels (PV) that would be necessary to generate that electricity.

After two years of operation, we are surprised at how much heat is generated by the unit located in the mechanical closet and how warm/hot this closet is. Making lemonade out of lemons, that is, taking advantage of this waste heat, we use this room to dry shoes in, and it’s also where the homemade yogurt goes to ferment and the bread to rise.

We are looking for a student to calculate how efficient this unit is, in comparing the winter electrical loading to that of our natural gas use at the rental home (same size) we were in prior to moving into PGH.

JTGMuir.com, installed by Bayside Mechanical, BaysideMech.com

2.1.10 Radiant Floor Heating, Living Room

More efficient thermal transfer reduces energy needs.

A variable-speed pump circulates warm water through tubing in the ground floor slab for winter comfort. Because of the large surface area, radiant slabs can deliver heat using lukewarm water (90°F), compared to other water-based heating equipment such as radiators and baseboards (160°F). The lower temperature improves efficiency at the heat source, allows the use of future solar-hot-water for space heating, and allows the use of an electric water heater (the Daikin Altherma) that would be less efficient at higher delivery temperatures.

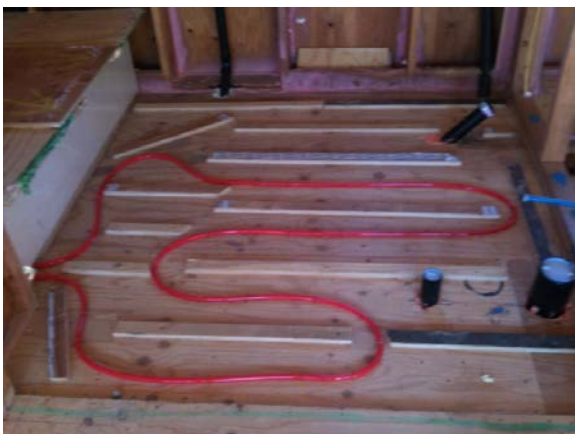

A conventional slab with tubing everywhere, running at full output, would be barely warm enough to feel, because so little heat is needed to maintain a warm room temperature.

Because heat delivered is proportional to (water temperature) x (surface area), we had to greatly reduce the surface area of tubing in this house to keep the water temperature warm enough to feel.

Hot water tubing was placed where the noticeable warmth would be most comfortable and social: the dining room table, the kitchen, the bathrooms, and walking paths around the ground floor.

After two years of use, we find the north side spare bedroom does not get as warm as the main ground floor as this room inherently does not capture the sun like the main floor does. As both rooms are on the same piping system, both areas get the same amount of heat from the radiant floor system per square foot. Additional warming for this room would have required either additional radiant pipes, closer together than those in main floor or a separate set of piping and temperature control for this room.

Bayside Mechanical, BaysideMech.com

2.1.11 Gas Fire Place, Living Room

The gas fireplace is our acceptance of, and nod to, our Neanderthal past, in that we occasionally like watching the flames flicker. In selecting the fireplace we had significant difficulties finding a small enough unit (<10,000 BTU), else we would roast inside. It will be interesting to see over the next winter how many times we actually do use it. This is the only natural gas powered device in the home.



2.1.12 Post & Beam Interior Designed for Remodeling, Library

Interior walls are not load bearing, so they can be remodeled easily.

The exterior shell of the house is largely self-supporting, and the interior is post-and-beam construction. Most of the interior walls are non-load-bearing, so they do not need a lot of structural wood, and they can be rearranged in the future should the family's needs change. We also put hot and cold water lines plus an associated drain and 20v wiring in the wall between the library and study should at some point we or a new owner wish to add a kitchen or move the kitchen to the back of the house.

2.1.13 Aging-In-Place or Extended Family, Study

Flexible space to use in many different ways, as family changes and grows.

The house has five bedrooms, including a ground floor suite with its own outside door that can accommodate an elderly relative, an au pair, elderly homeowners, or a young couple with a child. This bedroom and bathroom configuration strives to provide extended-family living, and flexible space for many future situations. To fully accommodate this, we also installed hot and cold water lines, a drain and 220v to the back area of the house, in case of an additional kitchen or relocated kitchen.

2.2 Insulation

2.2.1 Insulation Rating System/ Standard, Genevieve's Room

Insulation is one of the three keys to meeting the Passive House standard. While the house gets most of its winter heating from sunlight, there is still some energy spent to generate heat, and good insulation is required to conserve that heat as efficiently as possible. Insulation should also be combined with airtight construction in areas such as windows and doors to effectively reduce heat loss throughout the house.

The ability to insulate is termed the R-value, which essentially means the resistance to heat flow. The higher the R-value, the greater the insulating power. For insulation, the higher the R value the better, because a material with a lower R-value allows more heat to pass through (heat flow) under the same temperature conditions.

In California, houses are required to have walls with a minimum R-value of 13 to 21, depending on the climate zone in which they are located; Project Green Home's walls are required to have an R-13 value and actually have values of R-24 (second floor) and R-28 (first floor).

A summary chart noting California residential insulation levels over time follows:

<i>Insulation, R</i>	<i>1970's</i>	<i>2008, Title 24</i>	<i>PGH</i>
<i>Walls</i>	R-15 If insulated	R-15	R-28, 1 st floor R-24, 2 nd floor
<i>Ceiling/Roof</i>	R-15 If insulated	R-30	R-45
<i>Windows</i>	R-1	R-3 Center of glass	R-7 Center of glass
<i>Floor Slab</i>	None	R-15 If heated	R-18

2.2.2 Wall and Ceiling Insulation, Genevieve's Room

A Pro-Pink Complete Blown-In Wall System by Owens Corning was used to "super insulate" this home. Fiberglass was selected over a variety of other insulation products due to its

high R-value, light weight, high-recycled content and affordable overall price compared to other insulation systems. Not only does this degree of insulation keep the house warm in winter and cool in summer, but it also significantly reduces noise transfer from the outside and also from room to room.

Cellulose insulation was a competing option, but fiberglass has slightly higher claimed R-value, at half the density of cellulose. Lower density helps with sheetrock installation over the roof rafters; the fiberglass will not sag in its netting as much as cellulose would have. The only drawback to fiberglass insulation is the higher embodied energy (the energy used to create the material is approximately 10 times as much). Cellulose requires the least amount of energy to manufacture out of all types of insulation, for it uses recycled paper. In addition, cellulose waste can be recycled or decomposed whereas fiberglass waste is typically landfilled. However, because of the added energy savings of fiberglass, the total energy cost is eventually lower than cellulose roughly after 1 year.

The Pro-Pink Complete Blown-In Wall System is a two-step process. First, a fiberglass mesh blanket fabric is stapled to the faces of the 2x8 studs and then the L77 loose fill fiberglass is blown in, yielding an R-Value of R28. This compares to a typical fiberglass batt and blown in cellulose both yielding R-values of 25, assuming 2x8 studs. The blown-in system itself works better than other methods of installing fiberglass insulation because it keeps the insulation dry and avoids moisture that could reduce the fiberglass R-value. The loose-fill fiberglass itself was created from glass that has been molten and spun or blown into smaller fibers.

Sprayed polyurethane foam (SPF) insulation was not used for several reasons:

- 1) While SPF has a higher R-value per inch of thickness than other types of insulation, the blowing agents currently used have global warming potentials (GWP) far in excess of CO₂. It would take decades of avoided emissions while operating this zero net energy house just to offset the GWP emissions from installation.
- 2) Although SPF is inherently air and vapor-impermeable, this is unnecessary, since the house uses the exterior plywood sheathing as the air barrier. Air barrier flaws at the sheathing layer are easier to diagnose and repair. Vapor-impermeable materials in this mild climate prevent the free diffusion of moisture, which may damage assemblies over time. Water-blown, open-cell SPF does not have these issues, but its R-value is no better than cellulose or fiberglass.
- 3) Foam insulation costs more than cellulose or fiberglass.
- 4) Walls and ceilings with loose-fill insulation will be easier to open and reconfigure during future remodeling. Ease of remodeling is essential to extending the usefulness of a building.

2.2.3 Unvented Roof (Full Cavity insulation), Genevieve's Room

The entire shell of this house has full-cavity insulation. The attic is usable, conditioned space, and there is no outside air vented between the rafters as with a typical home.

Currently, the California Building Code requires rafter venting to prevent potential condensation damage in roof cavities. Condensation forms in roof cavities when a steady

stream of humid interior air enters the roof cavity through air leaks, and the top of the roof remains cold for long periods of time. This house is so well sealed against drafts that there is no supply of humid air, and the roof sheathing is insulated from above with 1" of rigid polyisocyanurate ("polyiso") board. To waive the requirement for rafter venting and allow the modern roof assembly, the design team had to submit a formal request including significant documentation to the City of Palo Alto. The request was approved.
BuildingScience.com



2.2.4 Insulated Header, Genevieve's Room

A header is the structural member spanning over an opening in a wall. Headers are typically solid wood and occupy the entire thickness of the wall, creating a significant thermal bridge.

Headers in this house are 3-1/2" thick engineered lumber, set to the inside of the 7-1/4" wall, with 3-3/4" of expanded polystyrene (EPS) insulating the header from outside temperatures. EPS (white and crumbly) is the eco-friendliest of the rigid, plastic foam insulations. White Cap Construction Supply, San Leandro.

2.2.5 Floor Insulation, Ground Guestroom

Expanded PolyStyrene insulation was also used under the concrete slab.

The slab was poured into a continuous "bathtub" of four-inch Type II EPS insulation that wraps up the sides to connect with the walls. This keeps the slab close to room temperature, even



without the radiant heat activated. In addition to improving comfort, slab insulation greatly improves the home's energy balance. Slab insulation can never be retrofit, so insulating properly was important. Four-inch thick EPS sheets facilitate installation since they are less breakable than thinner sheets commonly used. Further, scraps of this thick material were used to insulate headers and wall cavities.

2.3 Electrical Energy



2.3.1 Electricity & Electrical Wiring, Sophia's Room

Minimizing wiring holes in the exterior membrane.

To keep the home as airtight as possible, the wiring configuration minimizes punctures in the exterior plywood sheathing. To accomplish this feat, the majority

of outdoor wiring (serving the outside lighting, gray water pump, electric vehicle charging system) is addressed by an outside electrical panel. Further, as noted by the pictures, cuts through the outer wall have been made with the smallest hole that would allow the wiring through and sealed from the inside. A typical cut is on the right.

2.3.2 Photovoltaic System, Master Bedroom

Just a fancy word for solar panels.

A 5.9 kW photovoltaic (PV) system including locally designed micro inverters was installed on the west side of the home in March 2013. The system size is designed to cover the entire energy load of the house plus that of an electric car driving ~8000 miles per year. Based on system cost and projected generation over 25 years, electricity should be on the order of 7¢/kWh, this is compared to the current Palo Alto price of 16¢/kWh.

We endeavored to minimize the number of PV panels (that is the cost) required to achieve our zero net energy goal by locating the house as far back from the street trees as the City of Palo Alto would allow. This explains why we have the front covered porch and associated timber structure, this “front” is in alignment with all the other homes on the street while the body of the house sits ~8 feet back. Further, the roof slope conforms to the City of Palo Alto’s “Daylight Plane” requirements, which minimize the house’s shade on neighbors. Despite Planning Department constraints, annual PV generation from this roof is within 1% of that from a theoretically ideal slope and orientation, according to the PVWatts online calculator.

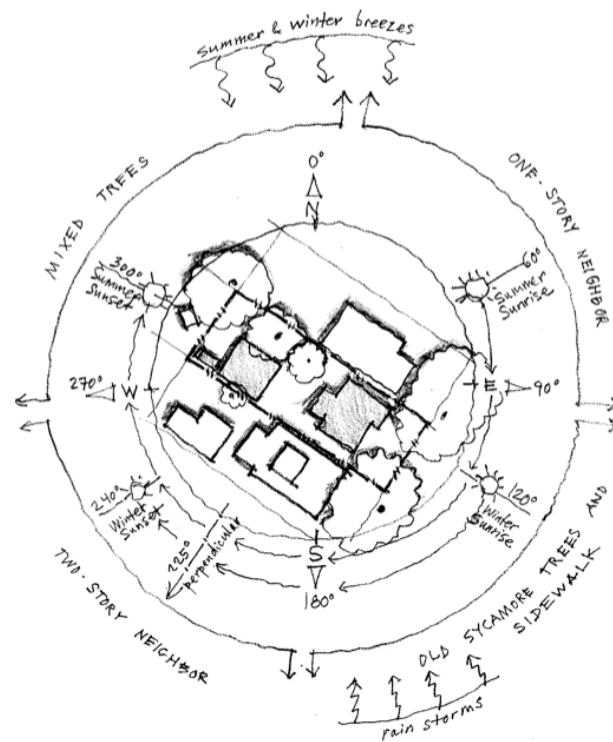

PVwatts.org

Further, we waited more than a year to install the system to determine actual electricity use and hence the PV system size needed. With this all-electric house, (heating, cooling, range, hot water, etc) we use roughly ~12 kWh/ day in the summer and ~22 kWh in the winter. In addition, we included electricity for an electric car at 4 miles per kWh and ~8,000 miles per year.

In late 2010, we reserved our spot in the Palo Alto PV rebate program at \$1.4/watt. As such, we encourage those interested in PV to reserve a place in the program ASAP for the rebates are based on a tiered system – the sooner one signs up, the larger the rebate. For example the October 2012 rebate was \$1.2/watt. Likewise, knowing that we were going to install PV, we included a ¾” EMT conduit from the roof to just next to the main breaker as part of the home construction. This was done to reduce installation cost of future PV and as a tradeoff between exterior wall punctures and exterior aesthetics.

In attempting to make the house “Solar Ready,” we made at least 3 mistakes. 1) We used a main circuit panel (the one that sits on the outside of the house) that positions the main house breaker at the top of the panel as opposed to one-third of the way down, 2) We should have marked the conduit as carrying electricity (Palo Alto has specific language for the signage) and had this piping inspected by the city before the sheetrock and insulation covered it up and 3) The conduit carrying the wires from the rooftop PV should have exited the house further from the main breaker panel.

As part of our community educational efforts, we partnered with Palo Alto Utility and Horizon Energy and held a “All you wanted to know about Residential Solar Energy But were Afraid to Ask” evening seminar at our local elementary school which was attended by ~12 families. PV Installer: Horizon Energy, gosolarnow.com

2.3.3 CAT6/Data Wiring, Desk Nook

We decided that data wiring isn't really necessary, with wireless connection.

We did not wire the house with CAT6 or other data wiring (except for phone jacks and cable) with the assumption that the future is wireless and will communicate via ZigBee or Powerline Carrier. In 2008 and 2009, and after touring numbers of houses that were wired with CAT6, this was a serious question. After two years of living in the house, this lack of wiring has not been a problem. However, what we still need to do is work out the sound system – if anyone has an interest in this project, please contact Sven.

2.3.4 Energy Monitoring System, Laundry Room

The central control panel for the PV, plus some additional monitors.

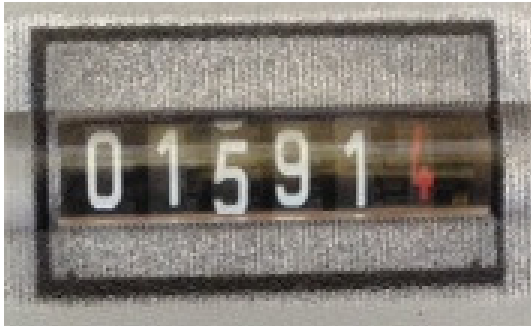

Our advice: Depending on your personality, it may be better to hire an energy efficiency company to do a winter and summer energy snap shot. On the other hand, you could integrate your smart meter with your photovoltaic generation feed to determine live energy use. If you decide to measure live usage, ensure there is room inside and outside the breaker panel(s), and be prepared to spend several thousand dollars on monitoring equipment, and also install a simple roll type

counter on the electric vehicle charging equipment. (If others charge their car at your house, it's quick and easy to know how much electricity they used.)

PGH Background: Initially, the thought was to use some form of whole house TED or TED like energy monitoring system to provide live data on 1) overall energy use, 2) that of a few large appliances (water heater, stove, EV chargers) and 3) photovoltaic generation. However, we have decided against this given the cost of a TED system combined with the need to build a stand or shelf abutting from just below the main indoors breaker panel to house the TED monitoring equipment plus same for the exterior breaker panel. If you are looking to do this level of live monitoring, understand 1) the up front costs (\$2k+ for our house); 2) likewise that you, your architect and electrician understand the necessary equipment needed and the associated space both inside and outside the breaker panel and 3) how to integrate multiple breaker panels. (For example our internal panel handles the inside electrics including the inside component of the 220v heat pump while the exterior panel handles the main feed from the city, the electric car chargers, and the exterior component of the 220v heat pump. Hence to accurately measure the heat pump, we need to operate two TED type systems, one at each breaker panel.



Instead, the non-profit Acterra*, as part of their energy audit services, provided a Blue Line Innovation Energy Monitor which reads the external utility meter (the classic spinning meter) and provides live data on the overall energy use (or generation if its spinning backwards) to a easily readable monitor inside the house. However this device was less than perfect in reading Palo Alto's old style spinning meter and/or in the data



transmittal to the indoor monitor and has been removed.

In addition, the photovoltaic system has its own website noting instantaneous generation plus daily, weekly, etc generation. Once we get a smart meter from the Palo Alto Utility (we are part of a pilot program for the city utility to evaluate the various smart meters) we hope to integrate the PV generation data with the city data.



As for the past year's energy use, utility bills indicate that we use ~12 kWh/ day in the summer and ~24 kWh/ day in the winter. This doubling in energy use is due to primarily the heating needs of the house (see Sections 2.1.8 & 2.1.9 discussing the radiant floor heating system) combined with additional electric dryer use (in the summer we mainly use a clothes line). These numbers are pre- electric car charger installation.

We have also measured a number of the 110v appliances with Kill-A-Watt meters. For example, the Heat Recovery and Ventilation system uses 40w; to wash a load of laundry takes 0.1kWh versus the dishwasher which is 1 kWh per load (it uses a built in water heater in the cleaning cycle). The Acterra Audit examined other 110v loads and identified a number of minor vampire loads such as the microwave. Vampire loads refer to appliance electrical use even when the appliance is off but not unplugged) We were pleased to find out that the flat screen TV, a 2012 purchase, has no vampire load.

Kate Latham, an energy consultant with WattzON.com has also volunteered to do a detailed examination of the 220v loads in the next several months.

*As part of Acterra's energy audit they provide & install the Blue Line Innovation Energy Monitor for free to houses that use more than 10kWh/day

2.4 Illumination

2.4.1 Daylighting, Study

More light from outside means less light from electricity.

Within the constraints of the Palo Alto City Planning regulations, the lot size, and surrounding trees and structures, we have attempted to bring daylight into the house to maximize livability and to reduce the need for electric lighting. The large dormer over the loft illuminates the central space. The open stairwell is lit from above by operable skylights. The master bathroom is also lit by a skylight. Most rooms have light from at least two sides to balance the color and quantity of daylight.

2.4.2 Electric Lighting, Guest Bedrooms

LED lights and compact fluorescents save significantly over incandescent bulbs.

The great majority of the lighting is either Light Emitting Diode (LED) or fluorescent. The wall sconce LEDs are made by Phillips and the LED recessed ceiling lights are model LR4 by CREE. The LEDs are incrementally more expensive than standard fluorescent lights, but

the payback on energy savings is rapid. In addition, LED lights are more cost effective than PV panels at reducing household energy drawn from the grid. Finally, compared to fluorescents, LEDs do not contain any mercury or lead and their dimming performance is typically superior.

In specifying the lighting, LED and fluorescent lamp color-temperatures were specified to feel warm and match our expectations of “home.”

Compare and contrast the lighting in the downstairs and upstairs guest bedrooms. Include in the evaluation the ability to properly dim the lights, light output, color and noise.

The total lighting energy footprint from the home’s approximately 60 different light bulbs was calculated to be just over 1 kW, the equivalent of 10 standard 100-watt incandescent bulbs, or 2, 500W halogen bulbs. The majority of the bulbs have also been scribed with the installation month and year to determine actual operating in-the-field lifetimes. In fact, so far, in the two years of living here we have not had yet had to change a light bulb – anywhere!



2.5 Interesting Materials

2.5.1 Quality Windows, Upstairs Guest Bedroom

Better windows, for better insulation.

We like the windows: their triple pane super seal and insulative qualities, the 2 ways of opening, and their look. They have a modern metal frame (nice colors) on the outside, with warm Scandinavian looking wood on the inside. Our one issue is that they open inward, so selecting appropriate drapes and curtains can be difficult.

About 25% of the windows have screens; some were placed to provide shading (kitchen) and others to prevent mosquitos from entering. As they were not ordered simultaneously with the windows, we went with a local manufacturer. We plan to keep screens on the windows for 3/4 of the year.

In an effort to spur North American manufacturers to improve their products, the house features triple pane windows and multi-panel doors by Sorpetaler from Germany. These units have thicker, stronger, better-insulating glass; better-insulating frames; and seal airtight. These features, combined with the attractive style, render them (sadly, in our opinion) superior to any American manufacturer as of early 2010. Sorpetaler windows are easier to install weather tight in any wall thickness because they can be set within the wall to optimize thermal performance, they permit over-insulation thereby further increasing whole window heat resistivity, and they have a modular aluminum sill and no nail flange. The block frame allows them to be taped airtight to the house. Sorptaler has also been working to reduce its company carbon footprint, which qualifies the company as a more

sustainable choice. It uses wood that has been sustainably harvested from forests throughout Europe and Scandinavia, eliminating a net loss of trees. Also, by our architect's calculations, shipping the windows by sea is less of a carbon footprint than a 500-mile truck ride (in comparison to mid-western US made windows)

The "U-value" indicates the level of heat flow through a window, with lower numbers being better. Typical North American windows (again as of early 20100 have a U-value of about 0.33, the Sorpetaler U-value is less than half, 0.14, and reach as low as 0.09.

To date we are quite happy with the windows and accordion door leading to the front side porch. .sorpetalerusa.com

2.5.2 Concrete Slab, Dining Area

Made with materials often considered waste products, which require less energy to process.

The concrete mix design uses 50% slag and fly ash in place of Portland cement, which reduces the energy needed to make the concrete. Additionally, the slag and fly ash have traditionally been considered waste products. The mix achieves 3000 PSI of compressive strength after 28 days. Star Concrete, San Jose.



Figure 10 Concrete Slab

The rich rust-color of the slab comes from a non-toxic mixture of iron sulfate, which is sold in nurseries as fertilizer. Several months after the slab cured, the owners, architects, and team of helpers mopped several coats of iron sulfate solution onto the slab, then scrubbed and rinsed it to achieve the right surface character. This not only gave us owners a sense of putting elbow grease into our own house, but was a lot of fun as well.

2.5.3 FSC lumber, Dining Area

Forest Stewardship Council lumber.



The majority of the lumber used in this house is either 1) certified by the Forest Stewardship Council (FSC) as originating in a sustainably managed forest. (A competing certification set-up by the wood-products industry, Sustainable Forestry Initiative, offers little real protection for sustainable forest management.) FSCus.org

FSC lumber is more expensive and some sizes are unavailable in some markets. These realities make it more important to conserve wood in the design. (See the Section on Advanced Framing: 2x8 studs at 24" spacing) and using salvaged wood where feasible (which has its own issues such as

potential lead contamination, and ensuring quality and standardization between the same specified type of material.)

2.5.4 The Tree Post, Dining Area

From sustainable logging, and presented to emphasize the connection with nature.

This madrone tree was thinned from a forest in Sonoma County. The upper half of the tree is incorporated into another a beam from a deconstructed house near Healdsburg. Using the un-milled beam brings a consciousness about the nature of building materials. The tree also relates to a traditional Japanese idea about deploying conspicuous materials in a manner that preserves and celebrates the inherent beauty of their unspoiled essence.



The tree is not a load bearing structure (it does not support the beam above) and yes the children have climbed it up to the 2nd floor. Because climbing strips the colorful bark off, please refrain from doing so.

2.5.5 Low-VOC Materials, Master Bedroom

Volatile organic compounds (VOCs) are used as solvents in products that are liquid-applied. Paint thinner is a common VOC. VOCs diffuse as gases to the air over time (off-gassing), creating poor air quality and health risks. Paints chosen for Project Green Home have very low or zero-VOC content; latex paints are one product where better manufacturers have eliminated VOCs. Other products were selected for low VOC levels that meet LEED for Homes criteria for health and safety. Some of these are: primers, clear wood finishes, floor coatings, wood stains, caulks, and adhesives. In general, LEED allows no more than 250 grams VOC per liter of product (less than 150 g/l for paints).

2.5.6 Hardie Plank, Carport



Hardie Plank is a wood fiber and cement composite material we've used for siding. It is extremely durable and dimensionally stable. The planks will last longer and have less environmental impact than other plank sidings.

2.5.7 Living/ Green Roof, Upstairs Open Space – Lost to Photovoltaics

The metal roof over the ground floor pop-out of approximately 220 square feet has a low slope and load bearing capacity of ~40 pounds per square foot which makes it an ideal

candidate for a living roof. We had planned to install a living roof, which would have reduced water run-off, and kept the room warmer in winter and cooler in summer. However, we have to use this area for solar power generation as the Palo Alto Fire Department required us to keep the photovoltaic panels 3 feet from the top roof line. As such, we could not maximize the panel orientation on the upper roof and were required to also install them on this lower roof. It is important to note that not all municipalities have this 3 foot from the roof line requirement.

2.6 Reconstructed and Salvaged Materials

While reusing materials intrinsically makes sense, be aware that there is likely substantial time and money required to bring these pieces to a suitable condition for use. On the other hand, salvaged pieces may also provide a sense of timelessness and add significant aesthetic value. We encourage the use of these materials but also acknowledge that there may be a number of caveats in their use.

2.6.1 Golden Bear Recycled Stone Tile, Living Room

Tiles from mining by-products.

This tile is made from non-toxic “dust” that is a by-product of the mining industry. The color comes from the parent rock, and is integral to the material. It has the hardness of stone, but without pores or microscopic cracks that might stain. The tiles used in this house are a prototype run from Golden Bear Ceramics (GBC). GBC is seeking investment to get the kilns up and running again. Jim Wood, Golden Bear Ceramics in Grass Valley, 530-320-1276.

2.6.2 Salvaged beams, Living Room

Structural timber recycled from previous construction.

Some of the primary structural beams in this house are reclaimed from a Vacaville farm and deconstructed Richmond warehouse. These beams are exposed because the wood is old and beautiful, because we want to tie the house to a long history of building in the Bay Area, and because we want to tell the story of re-use. C&K Salvage in Oakland, (510) 569-2070.



2.6.3 Windows Upstairs Foyer, Upstairs Guest Bedroom

These interior windows were first external windows which we believe were added to the original house during an unpermitted ~1970s expansion. As part of the deconstruction in preparation for building PGH, the windows were saved from the landfill and then cleaned (including removing most of the lead paint). Economically, these “free” windows are likely

an economic toss up due the labor involved in cleaning them. However, in addition to reducing the trash footprint of the deconstruction process, we also avoided the energy production associated with making new windows. Equally importantly, we like the aesthetics of these windows combined with the connection to the original house. Note: these windows should not be reused as exterior windows.

2.6.4 Sliding Interior Doors, Living Room

These antique glass doors borrow daylight from adjacent rooms to illuminate the living room/ library area. When they slide over the bookcases, the shelves can still be seen through the glass. The doors don't take up floor space when open, which is important for wide openings. While they do look lovely, preparing them was particularly laborious between stripping the (lead) paint, patching the holes in the woodwork and priming and painting them.

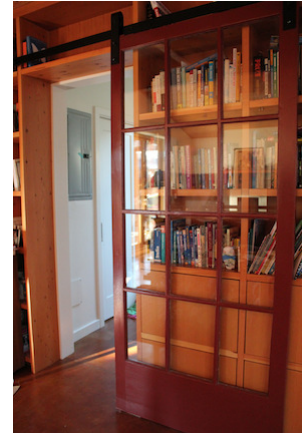

2.6.5 Wooden Flooring, Second Floor Hall

In selecting the wood flooring for the upstairs, Kate wanted something that reminded her of her Uncle Ken's wide planked 1700's New England home with its knots and nail marks. We found this in the clear-heart old growth Douglas fir from Stanford's Brown building complex built in 1914 and deconstructed in 2002.



According to Jim Steinmetz of Reusable Lumber Company from a transportation/ processing carbon perspective, the boards traveled under 150 miles from the source – to storage, to mill, to our home – which is 10 times more efficient than the industry average. Likewise the smaller boards came from a variety of homes on the peninsula. By Jim, conceptually, there are approximately 900 pounds of sequestered carbon in these floors.

These floors, while beautiful, have separated in a few places and we have found the wood to be softer than expected – or we are rougher on the wood! There are other sustainable flooring options that would have been equally effective including their aesthetic impacts and at a reduced cost. Finally, the builder (but not the flooring installer) has a real concern that the boards will become loose from the under-flooring in the mid-future.

2.6.6 Recovered Redwood Siding, Carport

Originally, the architects specified that the metal roof over the carport would be directly attached to the supporting beams. The roofers objected, as the roof would not hold and suggested placing plywood on the supporting beams and then the metal roof. Given that the plywood (and the manufacturing labels, stamps, instructions etc.) would be exposed to view and its cost, the team identified that recovered siding would accomplish the roofers goals, meet the architect's aesthetic requirements and not consume any new materials. It's important to note that the painted side of the siding faces up (and was not sanded) essentially encapsulating any lead paint. This was probably the best (environmental & cost) use of any salvaged material in the house.



2.6.7 Exterior Exposed Wood Siding, Living Room Porch

The exterior wood trim at the kitchen windows and siding at the master bedroom bay is salvaged redwood. Redwood is beautiful, rot-resistant, and will last for decades with minor upkeep. While this salvaged wood was challenging to work with (it splintered), the older wood is of superior quality and adds beauty and character to the house. Do note, as it is exposed to the elements, it does require annual staining to retain its color.



2.6.8 Front Fence & Vegetable Bed-Reused Material, Carport



The front fence and the raised vegetable bed in the back are constructed primarily of recovered redwood from demolished 25+ year-old fencing. In that, when we deconstructed the West (left) screening fence between us and the neighbors, we trimmed off the rotten tops and bottoms of the old five-foot long and eight inch wide pickets then cut them to size (3"x36") and planned them. We did the same to the 4x4" posts (as they were redwood, they were not treated with chemicals, etc) In addition to increase the new fence's life, the posts are mounted in metal stirrups, versus being planted in concrete. While the wood (posts and pickets) was free and estimated to be

worth \$1,000, the labor in preparing this wood was considerable.

Further, as we needed more material, we recovered additional old fencing that would have otherwise ended up in the landfill from Mike Hampel at Sturdy Fence (650) 969-2844. This includes some very nice 7' 4x6" posts that we intend to use as supports for the children's to-be-constructed tree fort.

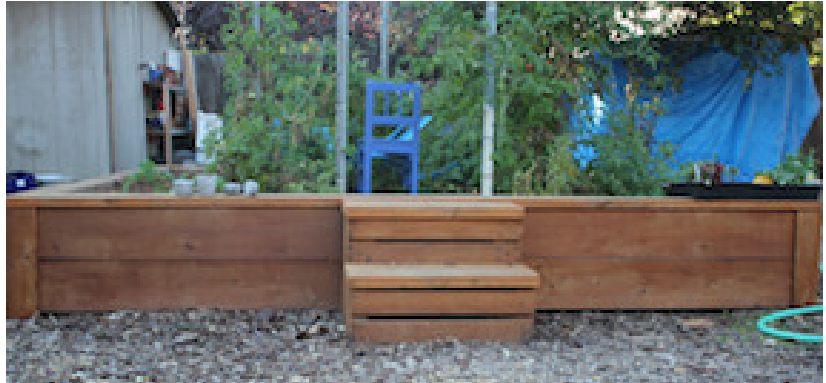

2.7 Water and Associated Energy Use

2.7.1 Recirculating Hot Water Line, Master Bathroom

Water is kept hot until needed. No more running the taps until it gets hot.

In a “structured plumbing” design, domestic hot water is plumbed in an insulated loop through the house, like a racetrack, with the water heater as the start/finish line.

Water sits in the pipe until an occupant presses a button near a faucet, which activates a pump at the water heater. The pump circulates the loop--water runs through the racetrack--until hot water reaches the tap and the pump shuts off.

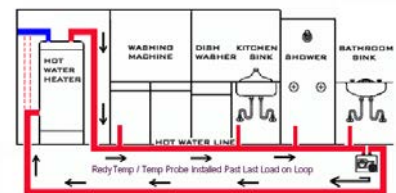

For us, this means there is very little time spent waiting for hot water at the shower. The shower ritual is now to press the button in bathroom, select clothes and by the time this is done (<2 minutes) , there is less than a 10 second wait for hot shower water – without wasting any water. How long is your wait at home?

This system saves both water and energy. Lukewarm water that was in the pipes goes back to the water heater to be reheated, rather than running down the drain while the occupant waits for hot. Since water recirculated inside the house is always warmer than water coming from the underground water main, the water heater consumes less energy bringing it up to temperature. GotHotWater.com

2.7.2 Drainwater heat recovery (Powerpipe unit) Downstairs Bathroom

Heat exchanger takes energy from water headed to the sewer and uses it to heat incoming water.



Soapy water that runs down the drain during a shower is still hot, but it usually runs directly to the sewer. Fresh, cold water is then heated to supply the shower. This house, however, uses a Powerpipe heat exchanger to pre-heat the incoming cold water using hot drainwater. A coil of incoming cold water runs in counter-current to the outgoing drainwater, which clings to the copper walls by surface tension and transfers heat. Free heat is reclaimed from the wastewater, taking a big load off the water heater during showers. Renewability.com

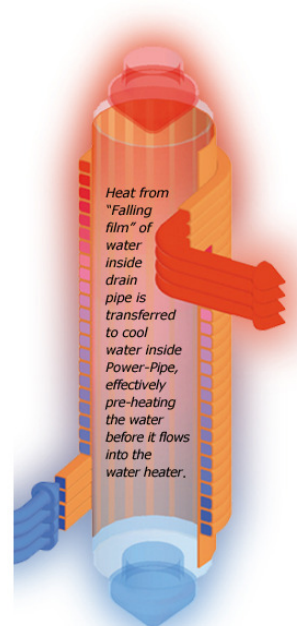

2.7.3 Toilets, Eco Flush, Childrens & Master Bathrooms

EcoFlush Ultra Low Flow and Urine-Diverting Toilet

We received approval from Palo Alto for a one-year pilot to install and operate two EcoFlush advanced ultra-low-flush (ULF) European toilets. This is the first time these toilets have been formally approved for use in the United States. As illustrated, the toilet has two compartments (solids and urine) which both currently drain to the city's sanitary sewer.

The EcoFlush toilet typically uses as little as 0.04 gallons (7 ounces) when flushing the urine compartment. Compare this to an old style 1.6-gallon (200 ounce) toilet and a modern 0.8/1.6 gallon per flush (100/153 ounce) dual-flush toilet. We find it interesting that people typically urinate anywhere from 5-20+ ounces per pee (a soda can is 12 ounces for reference) and that the typical home flushes with 10x the urine with fresh potable water.



How It Works - The user simply urinates in the front drain and defecates sitting back. The drains are located so that no additional effort is needed. A dual-flush flush button features two parts: one to flush urine and one to flush solids. Each

discharge line has its own trap. While both drains are sent to the city's sanitation plant, we hope to one day route the urine-only drain to the gray water system.

Problems and Solutions - The problems after two years of operation are the occasional 1) "poop on the pee side" as caused by our 7 & 8 year-olds failing to remember to sit at the back of the toilet rather than the front and 2) toilet paper blocking on the pee side due to the kids not putting it at the back. When this occurs, we remove the solids and then flushing the "urine line" with water. As the toilet's urine line drains to the home's blackwater drain and hence to the city sewer, there is minimal contamination risk. We have also posted signs above the toilets to educate guests on how to properly use the toilet, and so far all the blockages have been caused by the children. Note, the toilet vendor offered us a solution – an insert seat that re-centers the toilet seat to the back but we never took her up on it.

ecovita.net/products.

2.7.4 Toilets, Caroma Smart, Downstairs Bathroom

Caroma Smart toilet and hand washstand.

Downstairs we have a Caroma Smart toilet and hand washstand combination. Fresh water is used for hand washing and then flows into the tank to ultimately flush the toilet. It is also has dual flush capabilities at 0.8/ 1.2 gallon per flush. Using the above tank sink to wash one's hands displaces that same quantity of water for use to flush the outgoing waste. In essence it's a mini greywater system. What is interesting is time it takes to fill the toilet tank. The falling water from the top of the facet creates a noticeable noise (at least to most first time guests) which in turn triggers a conversation with the guest on how much water we use to wash away our body waste. caromausa.com/profile-smart



2.7.5 Graywater, Showers, Sinks, Laundry and 1% Urine, Laundry Room

Shower & sink water to water plants.

All the bathroom sinks and showers, plus the laundry and the urine stream from the Eco Flush toilets, have been double plumbed to drain into a future graywater irrigation system. The collection system exits through the slab on the east side of the house and runs to the front yard where it joins into the main black line leading to the street. Once we figure out the specific system, one that couples our greywater generation (estimated to be ~50 to 70 gallons per day) to the water needs of the landscaping, and how to address the Eco-Flush urine stream from we will work with the city to permit some form of graywater irrigation system. It may be an underground system or it maybe a series of ponds, maybe even some form of wetland. We welcome assistance in this area, please contact Sven or Kate if you wish to assist.

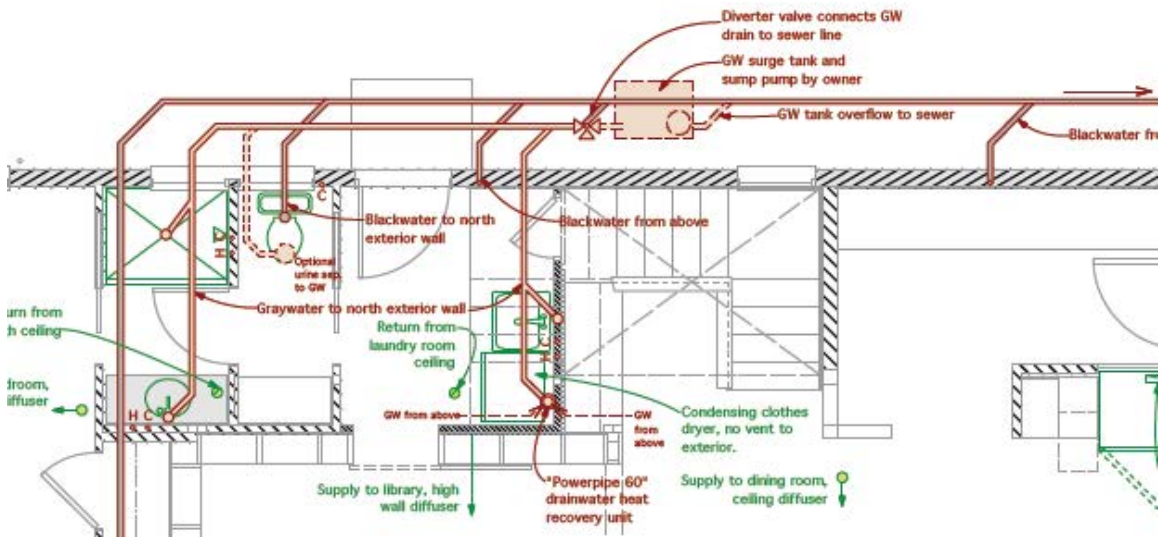
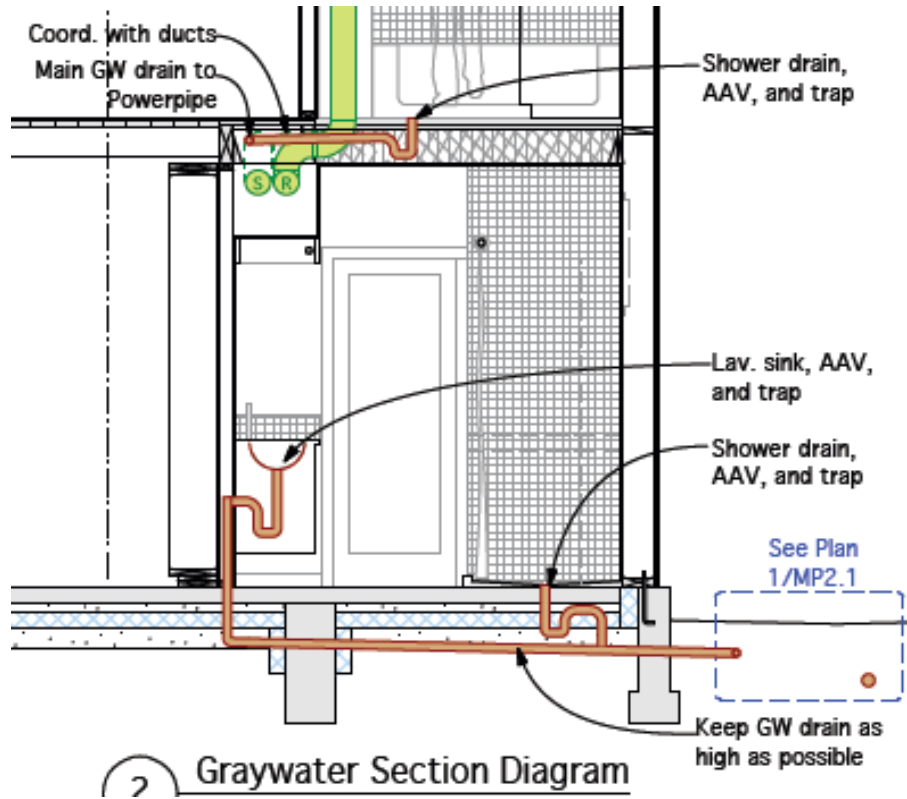

2.7.6 Graywater, Kitchen Sink, Kitchen

Palo Alto has granted conceptual permit approval for a kitchen sink graywater system. This is needed because the California Graywater Code does not include/ allow kitchen sink in their definition of graywater, because it tends to be relatively high in organic solids and grease, which can prevent water from infiltrating the soil. This will be a pilot program to evaluate use of a biofilter system to treat kitchen sink graywater onsite, which will include monthly evaluations of the system and a report to the city after one year.

An average 12 gallons per day of kitchen sink graywater flows down through a 3-way valve, powered by gravity, into an exterior 25 gallon biofilter vessel: a plastic box filled with wood chips, with a perforated top and bottom, situated about 20 inches below ground. Food particles and grease are filtered out by the chips' large surface area and rough edges, as the water percolates into the soil around them. Content left behind on the wood chips is aerobically decomposed by microorganisms.

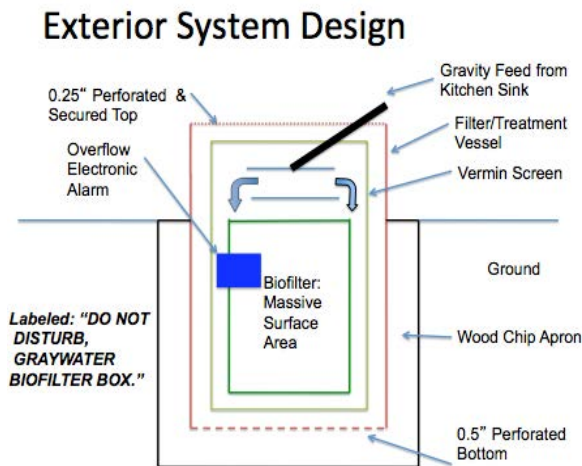

The goal is to eliminate our household's kitchen sink wastewater flow to the city's wastewater treatment plant, without creating a hazard or nuisance to the neighborhood (flooding, odors, etc). This will reduce treatment costs and greenhouse gas emissions for the city and residences.

Graywater System, Interior

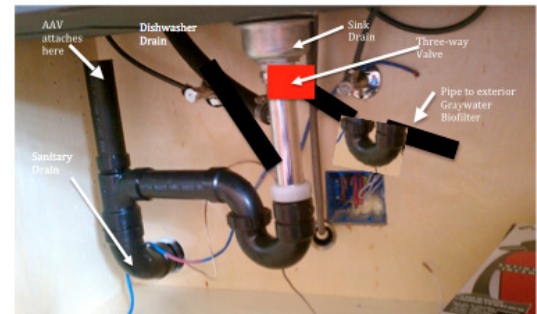

Picture 3: Kitchen Sink Plumbing Configuration with Graywater Diversion

Piping labeled: **"Graywater Drain, Do Not Drink"** or **"Sanitary Drain, Do Not Drink"** as appropriate.

2.7.7 Low Flow Shower and Sink Faucets, Downstairs Bathroom



Most importantly, the low-flow showers provide an excellent shower with solid pressure and what appears to be a large flow. In fact, we like them more than the high volume shower at the rental we were living in prior to PGH.



From an efficiency/ environmental perspective our showers meet EPA's WaterSense standard of less than 2 gallons per minute (gpm) flow and the sink faucets meet EPA's standard of less than 1.5 gpm. This compares to a standard new shower at 2.5 gpm+ and faucets at 2+ gpm. We were pleased to note that the Acterra environmental review plus two other follow up reviews by two different organizations likewise found that the showers do operate at these low flow levels. We win on comfort, plus both our wallet and environment win with the decreased use of energy and water!

2.7.8 Rain Water Collection, Backyard

Rainwater from all the roofs (~1,800 square feet) is collected and channeled to the northeastern side of the house (back right). At present it runs via a "rock stream" into a dry well, a large pit lined with a permeable geotextile membrane and filled with 1.5" diameter rocks. Because the rocks do not perfectly fill the pit, the interstitial space can hold roughly 100 gallons of rainwater, and with the large surface area of its bottom and sides, it accelerates rainwater absorption into the soil versus dispersing the water on the surface. Not only is it functional but the rock stream is also was an aesthetic feature in the landscaping. Before the children and chickens covered it up

This is an important feature in that historically, rainwater runoff from roofs, parking lots, etc. has been directed off-property into nearby streams which often leads to significant erosion, damaging the aquatic and riparian ecosystems. Or, potentially worse, the runoff has been directed into the sewer drain. This can lead to flooding at the wastewater treatment plant, causing untreated sewer wastes to flow into the receiving water body. By treating/dispersing all generated rainwater *on-site*, we avoid these problems.

Finally, by directing all of the rainwater to one downspout, we have the potential to collect and use this rainwater for irrigation and/or toilet flushing. However given the ultra low flow toilets, the need for this water is extremely small



and our Mediterranean climate of approximately four wet months followed by eight dry, makes irrigation difficult unless we were to install extremely large tanks - the excavation, soil disposal and installation of which has its own (large) carbon footprint and (large) cost.

2.7.9 Permeable Concrete, Front Entrance Porch

Both the small concrete driveway/pad and the front door concrete porch are made from permeable concrete. This enables rainwater to percolate through the material and into the soils below rather than pooling or running off into a stream or drain as discussed above.



2.8 Kitchen and Appliances

2.8.1 Inductive Range/ Stove, Kitchen

This has turned out to be one of our favorite devices in the house. In summary, the inductive stove has all the benefits of gas (ability to turn up and down extremely quickly) while using half the energy and safer for the user. For example, with an inductive stove, 84% of the energy goes to heat the food versus 75% for a typical electrical stove and only 40% for a gas stove. Because the surface of the cook top is only heated from contact with the vessel, the possibility of burn injury is significantly less than with other cooking methods. Obviously, the induction effect does not heat the air around the vessel, resulting in further energy efficiencies. It works by producing an oscillating magnetic field underneath the pot which induces an electric current in the pot. Current flowing in the metal pot produces resistive heating which heats the food. While the current is large, it is produced by a low voltage. Cooling air is blown through the electronics but emerges only a little warmer than ambient temperature. (Samsung Freestanding Induction Range FTQ307NWG from Sears.).



Inductive ranges are quite popular in Europe, particularly in restaurants as the design inherently produces significantly less waste heat than natural gas. As we like to cook and had never used one before, the architect had to challenge us to try it, to take a risk, and we are very glad that we did. This is another case of a triple (quadruple) win for convenience, comfort, cost and environment!

2.8.2 Refrigerator, Kitchen

The house has a conventional refrigerator that is EnergyStar-rated to consume 445 kilowatt-hours annually, one of the most efficient relative to its volume. Because the refrigerator runs continuously for decades, the design team considered using a direct-current refrigerator or superinsulated fridge such as the SunFrost. The high cost of the SunFrost relative to its energy savings means that using a conventional fridge and spending the incremental extra money on photovoltaics is a better conservation bang-for-the-buck strategy.



Given the short distance (~3 blocks) to currently two grocery stores and a conscious decision that as a family we do not need a standard sized fridge, we were challenged by the architect to go with a somewhat smaller fridge/ freezer with 18 cubic feet (the average American fridge for a family of 4 is 19-22 cubic feet.) To date, this has not presented a problem. Samsung model RB195ACPN.

Note, we have had problems with this unit, the drain keeps freezing and causing water to accumulate in the right bottom drawer and the internal thermometer is faulty causing temperatures to be lower in the freezer than what the display reads. By the multiple service technicians that have come out and replaced various parts, the cause has nothing to do with the energy efficiency features but a Samsung design problem. We would not get this particular model fridge again. These problems are causing the unit to use ~1.9kWh/day versus the rated 1.3 kWh/day.

Palo Alto also gives a rebate for energy efficient appliances such as this one.

2.8.3 Appliances, Sink Garbage Disposal, Kitchen



Given that we are avid composters, we simply opted not to install a garbage disposal. Room has been provided for one underneath the sink and the required electrical connection installed in the off chance that we change our current behavior. We do realize that we have to educate our guests on the composting program to ensure that we don't end up with blocked pipes.

Now that we have chickens, over half of the daily compost goes to them as food and the remainder, egg shells, food contaminated paper products, onion and leek skins, corn husks and the like get composted.

Composting activities at our rental housing have annually produced pumpkins over the years (they grow right out of the compost) and we transported two plants from the rental to the new house and are now in



our 2nd pumpkin generation here.

2.8.4 Kitchen Countertops, Kitchen

We selected a Paperstone countertop over Cambria, Silestone, Ceaserstone, concrete, wood, stainless steel, and Vetrazzo, each of which has its own pros and cons. Wood and stainless steel were eliminated over aesthetics. The remainder were scaled as indicated below. Note there was a small but vocal minority (Sven) that pushed wood due to its low environmental impact and low cost but was quashed due to staining potential, maintenance requirements and aesthetics. After a year's use, the countertop still looks beautiful. Gabby Beil, semolinadesign.com



	Weight	(Scale from 1 - 5)				
		Paperstone	Cambria	Silestone	Ceaserstone	Vetrazzo
Cost	3	1	3	4	5	2
Ease of care	2	4	5	5	5	5
Aesthetics	3	5	4	3	3	2
Green-ness	3	5	2	2	2	5
TOTAL		41	37	37	40	37

Weight definition

- 4 Very important
- 3 Important
- 2 Something to consider
- 1 Not a concern

Scale definition

- 5 Excellent
- 4 Very good
- 3 Good
- 2 Neutral
- 1 Poor

2.8.5 Kitchen Cabinetry, Kitchen

Originally we had chosen IKEA cabinetry as a cost containment measure. But after re-thinking this and realizing that the quality of the IKEA product may require that it be replaced sooner than a custom, wood-not-veneer option, we decided that paying for better quality cabinets from the outset may in the long run be cheaper and "greener". However, due to cost constraints we did not go full custom build. We went with Eco-Home in Berkeley and for semi custom FSC-certified/ low VOC cabinets. We found both the quality and customer service of Eco-home to be



lacking; note this has nothing to do with the environmental attributes of the cabinets. You are encouraged to talk to Sven or Kate before purchasing from Eco-Home.

2.8.6 Clothes Washer, Dryer, and Dishwasher. Laundry Room



These appliances are each ranked in the top ~25% best of class for energy/ water efficiency. Of note is the clothes dryer which is a condensing dryer and "vents" to the interior of the house. Given the Palo Alto climate we primarily let the wind and sun dry our clothes via a clothes line. What was surprising was measuring the clothes washer and dishwasher energy use. The clothes washer uses ~0.1kWh per load and dishwasher uses ~1 kWh, a



ten time more as it has a built-in electric heater.

Palo Alto also gives a rebate for energy efficient appliances such as these.

3 Landscaping, Work in Progress

In the spring of 2011, we engaged an extremely creative landscaper to design the garden. Unfortunately the resulting plan did not integrate the home's greywater generation rate of ~50 to 70 gallons water per day with the selected plants and the cost to implement the design was three times that of our budget. (Sven, the owner, thought I'd communicated these parameters to her!) We have significantly scaled down her plan and only landscaped the front with a combination of native and edible landscaping that provide for wildlife and

human inhabitants while looking reasonably attractive. At present, we are using a drip irrigation system with the goal to convert to grey water or non-potable shallow well water.

3.1 Cardboard Under the Oak/ Oxalis, Backyard

We used leftover cardboard as biodegradable ground cover to kill the oxalis (wood sorrel) growing under the oak tree drip-line. To us, the oxalis is a weed, aka a plant that is growing where it should not be growing. And we have been, in general, successful.



3.2 Chickens, Bees and other Pets



Chickens have been a surprising success. Having navigated the \$60 per year Palo Alto permitting process, we have three hens. They lay approximately an egg each per day. We feed them the majority of our compost (the vegetable, stale bread, burnt oatmeal, etc. component). The routine of collecting the eggs, particularly by visiting children, is quite enjoyable and the chickens are quite humorous to watch. The coop

(their bedroom, laying area, food and pellet food) was bought used \$150 on craigslist and the run, their daytime area, was made of scrap from recovered fence-boards and posts plus, of course, chicken-wire!

We also plan on bees but this is a longer-term project. The children are taking suggestions for other appropriate pets. (No donations please.)

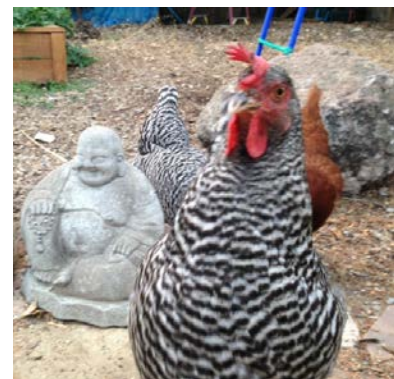

3.3 Fruit Trees

We have planted ~10+ fruit trees believing these to be extremely easy to maintain and harvest from. In just over a year of being in the ground, we have harvested apples, figs,

persimmons, plums, asian pears, and peaches. Yummy, healthy and an extremely low carbon diet!

4 Green Jobs, Master Bedroom

We acknowledge that the labor and material costs for a home of this nature are going to be more than the standard/conventional Californian home. On the positive side, to make these materials and provide the incremental labor, additional people will be employed. This is compared to the conventional home where more money (potentially significantly more money over the life of the home) will be spent buying energy, likely in the form of electricity (hopefully carbon free and from renewable sources) and natural gas (a fossil fuel and potentially from fracking, both bad). However, we believe the incremental employment created by the non-efficient home's energy demand is much less than the employment created by the more energy efficient one. (Power plants and natural gas production/ transportation simply do not require large numbers of employees) To confirm this position, we are looking for a student researcher(s).

5 Deconstruction, Master Bedroom

A 1920s, 2-bedroom, 1-bath termite infested house on the lot was deconstructed in late 2009 and the building materials were donated to a charity. Older homes are more commonly demolished, and the co-mingled waste is sent to a landfill. From an economic perspective, the donating/deconstruction path was essentially the same as demolishing the old house (though this may not be true everywhere).



More importantly, the new home (we very much hope) will comfortably accommodate an extended family and will age better than the previous house.

Recovered materials from the deconstruction include the interior single pane windows between the guest bedroom and the upstairs foyer, and Sophia's bedroom and the foyer.

In addition, we sawed the driveway into blocks and saved the more reasonable-looking (non-cracked) ones. Due to the limited size of the garden, we decided to freecycle them and they are to be pavers at Greg's house in the near future.. The rest of the concrete went for recycling.



6 Transportation

6.1 Plug In Hybrid Electric Vehicle, Ground Floor Foyer

Our latest car is an all-electric Nissan Leaf, “Mrs. Blue” which we got used for \$20k in November 2012. The car gets ~90 miles of range (depending on speed, etc) and costs, with our solar panels providing the electricity, less than 2-cent per mile to drive. Because of its great acceleration and handling, it’s the family’s favorite car to drive. Further, the children are the ones that do the fueling; they can and do plug the car in.

Our second car is a Toyota Prius converted into a plug in hybrid electric vehicle (PHEV) at Maker Faire in 2006 . It was converted to show the public, the automobile manufacturers, politicians, and pundits that plug-in hybrids work!



In essence, local miles are powered partly or fully by electricity, and then gasoline provides the standard 300mile+ range. PHEVs (like fully electric vehicles) tackle energy security, jobs and global warming, all at once.

These conversions were successful! The Chevy Volt with 40 miles of all electric range followed by 380 miles of gasoline driving for those long distance trips is selling like hot cakes. How long is your daily drive? Would an all electric or PHEV work for you?

Environmental and Economic Benefits: While running on typical California electric power (from PG&E and the other large utilities) there is a 75% reduction in CO2 compared to running on petroleum energy and provides a similar 75% reduction in fuel cost. Using Palo Alto Green’s carbon-free electricity, we have a zero carbon footprint while driving on electricity at a fuel cost of ~4-cents a mile. Compare this to ~20-cents per mile for a vehicle that gets 20 mpg and fuel at \$4/gallon.

6.2 Electric Vehicles & Charging, Front Porch

The house was originally built with 3 locations pre-wired to enable electric vehicle (EV) charging. The first is at the back of the house in the “carport.” The second is the concrete driveway pad plus a standard 110v outlet. The third is curbside. We recommend that all new houses come pre-wired for electric vehicles as it’s much cheaper to pre-wire during construction than to retrofit later.

To promote EV driving, and facilitate charging when away from home, our house is listed on plugshare.com and we have charged unknown numbers of EVs through this portal and are likewise happy to charge your EV for free!

To facilitate EV charging, in September, PGH put forth the following to city council which was adopted unanimously:

Understanding that the city of Palo Alto wishes to take a leadership role as one of the most EV friendly cities in America, we encourage City Council to:

- 1) Require all new parking construction (residential, industrial, commercial, research and development, etc) install, to some appropriate percentage, the necessary circuitry etc to be EV charger ready.*
- 2) Streamline the EV charging permitting process and reduce the fee;*
- 3) Include residential curbside charging as an option in the requested staff report; allow encourage and support residential curbside charging on a case by case basis and not limit the current pilot (the first in the nation) to one home.*

And we encourage those in other cities to request their city council enact a similar ordinance. Especially given that the effort to get this passed was less than expected.

***My home EV Charger, my fueling station,
is always open, and there’s never a line.***



6.3 Curbside Side Electric Vehicle Charging Stations, Front Yard

As most are aware, with an electric vehicle (EV), one typically installs a charger at the driveway or garage. We wanted a second charger to serve EVs parked on the street outside our house, but the land between the street and the sidewalk is public property. We got a 2-year pilot permit to install and operate this curbside charger, from the city of Palo Alto. And we are providing the electricity for free! To our knowledge, this is the first such permit in the nation. If you are interested in doing same, see our website for the full saga and the issued permit which may help you in your quest. Why did we do it? To promote the technology, help reduce range anxiety, have a place for guests to charge when visiting, initiate conversations around fueling EVs and to begin normalizing residential curbside charging.

FREE CHARGE

Electric Car Charger
Please return the cord to this box on completion

This public charger is the nation's first known curbside residential charger. To see how we got the city permits go to ProjectGreenHome.org.



Electricity is provided for free by the home in front of you. If daylight, you are charging on 100% carbon-free renewable sunshine! If night, then it's 100% carbon-free with Palo Alto's electrical mix.

Did you find this charger helpful? Consider joining Plug In America - the voice of the EV Owner - at these suggested donation levels:

- Leafs, Volts, etc: \$50/year
- Teslas & BMW i3s: \$250/year

Plug In America (PIA) drives change, accelerating the shift to plug-in vehicles powered by clean, affordable, domestic electricity to reduce our nation's dependence on petroleum and improve the global environment. PIA played a pivotal role in the \$7,500 rebate you received when you bought your EV and supported ProjectGreenHome.org in acquiring this charger through an arduous and lengthy permitting process.



7 Mistakes Made Along the Way, Downstairs Guest Room

7.1 Polyvinyl Chloride (PVC)

While PVC as a material is useful, its manufacturing process is quite toxic and burning it releases toxic gasses such as dioxins. Hence, as a society we should not use it unless absolutely necessary. Unfortunately, because of its usefulness and lack of awareness of PVC's life cycle toxicity, it can be a common building material. According to the Healthy Building Network, over 14 billion pounds of PVC are produced each year, 75% of which are used for construction due to its inexpensiveness and versatility for building. Though this material is often used, producing PVC can inadvertently emit toxic chemicals that can cause cancer, neurological damage, and other damaging side effects. Dioxin, an extremely powerful carcinogen, has also been found to pollute ecosystems and humans alike, causing dangerous health hazards to both people and wildlife. PVC also contains diethylhexyl phthalate (DEHP), which is a plasticizer that can escape from the plastic and have hazardous effects on the environment after long-term exposure. PVC is also non-recyclable due to its high additive content and is an official contaminant.

Our mistake was not to specify at the beginning of the process that we didn't want to use the material and to work with the architect, builder, city permitting authorities and craftsmen to find alternatives. As noted below, we inadvertently used, and in some instances have been required to use, PVC materials.

PVC Conduit for the Photovoltaic System

Rather than mounting the wiring conduit for the photovoltaic on the exterior of the house (running from the west roof down the east roof and then down the exterior of the east wall), we opted to run the conduit internally. Aesthetically, this keeps the smooth, clean exterior lines of the house. However, in running the conduit internally, we had to puncture the house membrane both at the roof and the side of the house. Using metal conduit would have allowed significant heat loss (and gain) into the house due to metal's ability to conduct heat. The option taken was PVC conduit. Any suggestions of materials we could have used are most welcome.

PVC 4" Drain Pipe Around the house to the Sump box

The California State Building Code (?) City of Palo Alto requires a 4" pipe around the house slab foundation. This perforated piping collects any water that might pool around the house and drains it to a sump box/bubbler that sprays it on the yard. Again any suggestions of materials we could have used instead are also welcome.

The Heat Exchanger Condensation Drain Line

The heat exchanger in the attic has a condensation pipe made of PVC. It's not clear if PVC piping is required or there are other options. In our case, it's what came with the unit and what the HVAC crew installed. (In winter, the heat exchanger pulls external air into the house, heating it from the exiting warm interior air, which in turn cools. A portion of the water vapor in the new cooler exiting interior air may condense out depending on the

interior/exterior temperature delta and the interior air water content.) One simple option would have been to use PEX, the same material used in the water pipes.

Stucco Edges

There are some concealed PVC edges on the stucco that we tried to substitute with galvanized steel, but we were unable to find a manufacturer that makes a metal equivalent or other material. Further, if we did find something, we would likely have the common problem of the installer refusing to use it because it's not part of the approved system and if installed becomes the contractor's liability.

PVC in electrical Wiring

Another issue, discovered post-installation, is the PVC insulation on our electrical wiring. Other rubber or plastic options may exist, but we have not researched them. (At this point, it is too late to replace existing wiring.)

7.2 Screening Fence West Side Between the Neighbors

In essence, we missed the opportunity to improve the backyard view-shed for us and our neighbor.

The Redwood (6 foot high) screening fence between us and our west (left) neighbor needed replacing. We and our neighbor agreed to replace it with essentially the same fence style and hired a contractor to do so. When the old fence was removed, we temporarily installed a low "dog fence" between the two houses. This low, somewhat innocuous fence was in place for ~2 weeks and increased the view-shed into each other's backyard plus provided more opportunity to be "neighborly." After the new fence was installed we (and the neighbors) realized we had traded the view and increased interaction with great neighbors for privacy. Given the chance to do this over, we may have opted for a lower fence in the back for these same reasons.

Further, we were also unable to find Forest Stewardship Council redwood lumber. However, we did mount the posts in stirrups and dug a 3-inch trench along the bottom of the fence and filled with drainage gravel, in efforts to decrease rotting.

8 Regulatory Barriers, Upstairs Open Space

Where we yielded to City permitting

8.1 White Roof

As discussed in Section 2.1.6, White Roof, we were not allowed by the city of Palo Alto to install a white roof. "...*The City is concerned about the potential impacts associated with glare and given the close proximity of homes in this neighborhood we believe this is a valid concern...*" As such, our building permit includes "*conditions of approval to assure the metal roof will not be painted white...*"

What is particularly interesting is the immediate city to the North, Menlo Park, seems to have embraced white roofs. See MenloGreen.TypePad.com

8.2 House Positioning

To gain maximum potential solar energy for the roof-mounted photovoltaic system, we needed to put the house in the rear of the lot rather than the front. Unfortunately because the majority (but not all) of the houses in the neighborhood are towards the front, we were likewise required to build the house towards the front. We have not yet worked out how much additional photovoltaic panels we will have to install because of this Palo Alto aesthetic requirement. If we had positioned the house at the back of the lot, according to the city we would have disturbed the “warp and the weave of the neighborhood.”

8.3 Garage/ Carport Requirements

It is understood that the garage or carport requirement stems from the city’s objective of keeping the residential streets clear of “car clutter.” Unfortunately this policy seems to be ineffective in limiting the numbers of cars parked along the curbs. Further, as the majority (but not all) of the garages in the neighborhood are at the back of the lots, we likewise were required to include a rear garage/carport. This meant that valuable land on the side of the house had to be used as driveway versus a garden or play area. Further it forced the house to be more rectangular than desired, again causing a larger footprint over arable land. This was a permitting battle that we lost with the city of Palo Alto as we did not go high enough up the chain-of-command. Do not repeat our mistake! If need be, Sven and Kate the owners will go with you to city hall to prevent this from happening again. In our case we built a rather expensive outdoor, covered table tennis playing area that legally meets the definition of a carport. We park our electric car outside at the front on the short permeable concrete driveway beside the electric vehicle charger. The photo shows a home that we could have had with the garage at the front.



8.4 Graywater infused with 1% Urine

The laundry drain, all of the sinks and showers, plus the urine diverting toilets are kept well separate from the blackwater line. Given the 1% urine, permitting this system with a flow rate ~50-70 gallons per day is difficult. And we are looking for volunteers to assist..

9 Partners, Study, Upstairs Guest Bedroom

Research Institutions, Non Profit Organizations and Universities

9.1 Lawrence Berkeley National Laboratory (LBNL)

LBNL has conducted several tests on the home to determine airflow efficacy and levels/types of airborne chemical contaminants in tightly sealed homes such as ours and we are awaiting results of these studies.

9.2 Acterra

Acterra, a local non-profit environmental organization has conducted a performance review/ audit of the home via its Green@Home program. The Green@Home program allows everyday residents to play their part in combating climate change by delivering house calls to citizens in the Bay Area to help install energy saving devices and draft plans to reduce waste. During the visit, the total electricity, gas, and water usages were determined, as well as ways to reduce both consumption and costs. One finding of note at PGH was determining that the fridge's freezer compartment, while indicating -2C on the display (an appropriate temperature), the in-freezer measured temperature was -12C. We were wasting energy by keeping the freezer colder than necessary (we measured 1.9 kWh/day versus the rated 1.3 kWh/day, see Section 2.8.2) and this likewise explained the extremely hard ice cream. The freezer was found to have a faulty sensor which has since been replaced. The full report is in Appendix 2.

In summary, we would encourage every homeowner and renter to participate in the free Green@Home program, not only will you save energy but also money.

In addition, Acterra has adopted the educational component of Project Green Home. As such interns, and we are always looking for more, are being funded via tax-deductible donations to Acterra to perform research on the house, serve as docents and other educational related tasks.

9.3 Bay Area Climate Collaborative (BACC)

The BACC has been quite supportive of PGH particularly in serving as the lead organizer for PGH's June 2011 open house, which attracted over 400 attendees. This support stems from PGH and BACC sharing the same objectives in respect to green/ clean technological innovation and implementation, green jobs, and the imperative need to address global warming.

9.4 UC Berkeley

Early in the design process, graduate students assisted the architect in running various energy efficiency calculations/models for each of several initial designs. In addition, a group of undergraduate students calculated and wrote a paper evaluating how much photovoltaic energy would be required to make PGH a zero net energy house (they underestimated by ~20%). Finally, PGH has been included in various grant applications as a potential research subject by both UC Berkeley and Stanford.

10 Providers

The companies that built our home.

10.1 Architect – Arkin Tilt

Arkin Tilt Architects is an award-winning firm specializing in energy and resource efficient design. Our projects embody a marriage of thoughtful design and ecology, creating spaces that are comfortable and lyrical. We pay particular attention to the integration of the built

and natural environments—from siting to careful detailing. We have extensive experience with alternative construction systems, including straw-bale and rammed earth, renewable energy systems, gray water, and non-toxic and recycled materials. Our projects include residential and commercial, park buildings, religious facilities, and Eco-Resort planning and design.

Winner of the Acterra Business Award for the Sustainable Built Environment, two COTE/AIA Top Ten Green Project Awards, and numerous other design awards, our work has been published nationally and internationally for excellence in design and sustainability. With electric and biodiesel cars and solar electricity, we are working to limit the office's carbon footprint. 510-528-9830 ArkinTilt.com

10.2 Construction Project Manager/ Builder/ Passive House Consultant

Joshua Moore, owner of Red Company LLC, is the Project Manager responsible for the home's construction. In addition to his Project Management skills, he is both a licensed architect and contractor, plus a Passive House Consultant who brings a wealth of building and design experience to the project. Moore is an advocate for the Design-Build process in that "only through accepting, embracing, and knowing the hard realities of construction will we be able to affordably and practically design our way to a better future." 510-812-5688 RedBuildings.com

10.3 Plumber - Moomau

Moomau Plumbing is a plumbing repair, construction, and replacement service with over 30 years of experience. A fully licensed and insured contractor, based in San Jose, Moomau plumbing serves the greater Bay Area for plumbing needs of all kinds. 408-396-3837 MoomauPlumbing.com

10.4 Roof - Custom Copper and Sheet Metal Roofing

Custom Copper and Sheet Metal Roofing is excited to be a part of Project Green Home. As third generation sheet metal experts, they are pleased to bring their sheet metal installation expertise to the Cool Metal Roofing system that will be used to further achieve a zero net energy home. Though they have been designing and installing similar sheet metal and copper roofing applications for many years, the recent technological advancements in the metal roofing finishes over the last several years have given way to "Cool Metal Roofing" products. Cool Metal Roofing systems provide a number of advantages over conventional roofing products. Some of these advantages include EPA EnergyStar approved high reflectivity values, up to 85% heat emissivity values, 45-year plus durability warranties, and the knowledge that metal roofs are 100% recyclable.

These fine metal products are also skillfully installed by their staff on additional building applications including siding, awnings, flashing, gutters and other exterior sheet metal customizations. 916-346-5436 Ccsmr.com

10.5 HVAC - Bayside Mechanical

Bayside Mechanical installed the Altherma unit (hot water for both the radiant floor system and potable water), the radiant floor system and the heat-recovery ventilator. They offer

expert mechanical engineering and plumbing services. Throughout the Bay Area they have helped residential and business customers achieve their desired Heating, Air conditioning, and/or Ventilation goals. Based on your needs Bayside Mechanical Inc. will design, install, service and/or repair any Heating, Ventilation, and Air Conditioning systems. Specializing in both residential and commercial projects, Bayside Mechanical is your solution for all your Heating, Ventilation, and Air Conditioning needs. ☎ 650-578-9080
BaysideMech.com

10.6 Insulation – Tri-County Insulation

Tri-County Insulation and Acoustical Contractors is proud to be a part of Project Green Home. They have been specializing in insulation products in the Bay Area for over 36 years. As time has passed, the technological advances in insulation have escalated and so has the interest in insulation. As insulation has advanced so have their skills and knowledge of what can be done to make homes more energy efficient with cleaner air and more comfortable, responsible living.

The Owens Corning's Energy Complete System was used on Project Green Home, along with Pro-Pink Complete Blown-In Wall System, also by Owens Corning. Pro-Pink Complete Blown-In Wall System has a high recycled content of 53%, Green Guard Certified, and low VOC's. 800-246-7858 TriCountyInsulation.com

10.7 Stucco – Green Wall Tech

Green Wall Tech provided and installed the stucco. Their focus is drywall systems, plaster & stucco systems and architectural detailing and trim projects. 510-252-1170
GreenWallTech.com

10.8 Student Booklet Editors

Jessica Tam is a current senior at Palo Alto High School who has been collaborating with Sven Thesen and Project Green Home to provide updates and conduct research for the booklet. Her prior experience working with the environment includes an internship with the Acterra Stewardship Program, performing habitat restoration for Arastradero Preserve, and regularly volunteering with CuriOdyssey, an environmental education museum located in San Mateo. Jessica is also the 2012-2013 Associated Student Body President at Paly and a member of the Pacific Ballet Academy Studio Company. She enjoys educating the public about environmental consciousness and sustainability and hopes to pursue a future career in renewable energy.

In Memoriam



Dr. Edgar Wayburn, M.D., 1906-2010

Dr. Edgar Wayburn has been described as “America's most effective (and least known) wilderness advocate.” A five term president of the Sierra Club, he was a major factor in the creation of the Golden Gate National Recreation Area, which includes roughly 200,000 acres in south and west Marin, San Francisco, and beyond. No other city in America -- perhaps the world -- has anything that can compare with it. When Dr. Wayburn was awarded the Presidential Medal of Freedom in 1999, President Clinton said, "He has saved more of our wilderness than any person alive."

Dr. Stephen Schneider, 1945-2010

Stephen Schneider was a renowned climate change researcher. A professor of biology at Stanford University, he founded the journal *Climactic Change*, and served as a scientific consultant to the White House under every president since Nixon. A MacArthur Fellowship recipient, and author of two books and countless scientific papers, he shared the 2007 Nobel Peace Prize with former Vice President Al Gore and the other United Nations Intergovernmental Panel on Climate Change scientists and engineers.



11 In Memoriam

11.1 Dr. Edgar Wayburn, M.D.

Dr. Edgar Wayburn died on March 5th, 2010, at the age of 103. In his life, he served as president of the Sierra Club for five terms, and he has been described as “America's most effective (and least known) wilderness advocate.”

Dr. Wayburn was the leading force in the expansion of Mt. Tamalpais State Park, from a mere 870 acres to more than 6,000 acres. Later, he spearheaded the establishment of Point Reyes National Seashore, the first national park unit of any size near a major metropolitan area. That was followed by the formation of Golden Gate National Recreation Area, which combines nearly all the open space in south and west Marin, plus some lands in San Francisco and beyond, including the city's beaches, Alcatraz and the Presidio. All told, it amounts to some 200,000 acres. No other city in America -- perhaps the world -- has anything that can compare with it.

For all his accomplishments, Ed Wayburn was never a full-time conservationist. A practicing physician and a family man, he dedicated his spare hours and weekends to the health of the planet. Neither was he well known, even within the environmental movement, having never gained the wide recognition of such contemporaries as David Brower and Ansel Adams. The low profile suited him fine. Dr. Wayburn preferred to do his work quietly, behind the scenes. He was a born facilitator and diplomat, someone who exuded the kind of authority and integrity that gets people -- even powerful people -- to listen.

Where others might have been content to save random parcels of land -- whatever scraps could be spared -- Dr. Wayburn wanted nothing less than the protection of whole watersheds. As he explained in his memoir, *Your Land and Mine*, "It wasn't enough simply to add a few acres here and there; nature doesn't divide herself into measured plots. A watershed encompasses the chain of life; if any part is developed, the integrity of the whole ecosystem is threatened."

That devotion to ecological principles guided him through many subsequent wilderness campaigns, including the decades-long struggle to found, and later expand, Redwood National Park. Years of travel in the Alaskan backcountry with his wife Peggy -- herself a prominent wilderness advocate -- led eventually to his crowning achievement: Passage of the 1980 Alaska National Interest Lands Conservation Act, which created ten new national park units and effectively doubled the size of America's National Park system. When Dr. Wayburn was awarded the Presidential Medal of Freedom in 1999, President Clinton said of him, "He has saved more of our wilderness than any person alive."

Most of this biography is taken from the Sierra Club website, and was written by Pat Joseph, the executive editor of California magazine.

11.2 Dr. Stephen H. Schneider

Stephen Schneider was a professor of biology at Stanford University. He died of a heart attack on July 19th, 2010, on his way back from a conference in Sweden. He was a leader among the Intergovernmental Panel on Climate Change scientists and engineers, whose climate research earned a Nobel Peace Prize in 2007, an honor they shared with former Vice President Al Gore.

Schneider was influential in the public debate over climate change and wrote a book, *Science as a Contact Sport: Inside the Battle to Save Earth's Climate*, about his experiences. He also wrote a book, published in 2006, about his battle with mantle cell lymphoma, *Patient from Hell*. He drew a parallel between his climate-change research and his involvement in designing the treatment regime for his cancer. In both cases, he said, there was a need to predict the future with incomplete evidence, and yet there was no room to be wrong.

"The Stanford family is profoundly saddened by the loss of Stephen Schneider," said Stanford President John Hennessy. "He was a valued member of our community and a passionate advocate for our planet. A world-renowned scholar, he focused on the impact of human activities on climate change in his teaching and research, and his contributions extended well beyond our campus. Through the many ways he sought to increase understanding of the implications of climate research among the general public, policy makers and global leaders, Stephen Schneider worked to make the world a better place for us all."

At Stanford, Schneider was the Melvin and Joan Lane Professor for Interdisciplinary Environmental Studies, professor of biological sciences, professor (by courtesy) of civil and environmental engineering, and a senior fellow in the Woods Institute for the Environment.

In recent years, he mourned, with his usual high level of verbal energy, the loss of talented science writers from newspapers. In the sound-bite feuds of television, he said, climate researchers were given a scant few seconds to explain complicated issues. "So what I'm trying to do is get media and the political world to stop framing climate change in either/or terms, when we're really looking at a bell curve of possibilities," he recently told *Stanford* magazine.

Said Pamela Matson, dean of Stanford's School of Earth Sciences: "He is irreplaceable – as a colleague, adviser, friend and scientist. In his science, he has done more for the world than most of us recognize, and our children will thank him."

Most of this biography is taken from Stanford University's website, in the News section, and was written by Louis Bergeron and Dan Stober.

From: [Paul Wermer](#)
To: [Peskin, Aaron \(BOS\)](#); [Safai, Ahsha \(BOS\)](#); [Preston, Dean \(BOS\)](#); [Major, Erica \(BOS\)](#)
Cc: [Stefani, Catherine \(BOS\)](#); [Mullan, Andrew \(BOS\)](#); [SF Climate Emergency Coalition](#)
Subject: Today's hearing: File # 200701 [Building Code - Mandating New Construction Be All-Electric]
Date: Monday, September 21, 2020 8:34:12 AM
Attachments: [restaurants with all-electric kitchens.pdf](#)

This message is from outside the City email system. Do not open links or attachments from untrusted sources.

Dear Supervisors:

This draft legislation is a major step forward in San Francisco's actions to reduce our greenhouse gas (GHG) emissions, recognized as a critical problem in the April 2019 Climate Emergency Resolution.

It is unfortunate, however, that the exceptions offered in the June 30 draft legislation (and the related draft Department of Building Inspection policy for implementation, AB-112) establishes multiple exceptions that are not necessarily in the public interest, but rather are predicated on financial considerations of the developer.

It is important that these issues be addressed now – because any new buildings with natural gas only complicate the future problem of retrofitting the existing building stock in a timely manner.

There are two issues that must be addressed: 1) A transparent exception process that identifies buildings seeking an exception and a public hearing, similar to Planning's Variance hearings; 2) Requiring that any exception be justified as being in the public interests, similarly to Planning's process for granting Conditional Use Authorization to a project.

There are a few cases where an exception is appropriate. These are the circumstances where an adequate electrical supply cannot be provided to the building due to current (but not future) grid constraints, and the building is built as fully electric ready. In this case a building can be readily converted to all electric with minimum disruption to the occupants, as the infrastructure enables replacement of the gas appliances with electric appliances without structural changes, interior demolitions, etc.

No use of natural gas in a building should be permitted without an exception. This is not an energy code, after all, but a health and safety issue, as SFE has made clear.

There are some activities that require a natural gas feed – such as producing hydrogen gas via steam reforming. There are many reasons why a steam reforming plant has no place in a dense urban environment such as San Francisco.

But after excluding industrial processes that have no place in San Francisco, a review of available technologies reveals that everything from high fire ceramics kilns to Bunsen burners have electric alternatives.

In the exceedingly rare case where a gas flame might be required for an essential test or process, there are much safer alternatives to the traditional Bunsen burner. These alternatives

offer much more precise control and do not require natural gas plumbed to the building. Permitting uses because they are not related to space conditioning, water heating, cooking and clothes drying is not justified, given the health and safety concerns of natural gas use in buildings.

It is abundantly clear that all-electric restaurant kitchens are not only possible but preferred because of the increased control the of the cooking process (see attached).

In short, there is no need for gas in San Francisco, provided adequate grid capacity exists – and the electric technologies are far more energy efficient than gas.

Yet in San Francisco, the combination of Public Works, Planning and PG&E requirements for locating a transformer needed to supply electricity to a large building may make it impossible to provide adequate electric power to the building. And so DBI has decided that, for “small infill lots”, they will automatically grant an exception, even if it is possible to locate the transformer in a sidewalk vault in the public right of way. For some reason, even though everyone agrees financial considerations do not justify an exception, requiring installation of a transformer in a sidewalk vault, even when it meets Public Works criteria, does justify an exception.

Worse, in those cases where a transformer cannot be placed a sidewalk vault because of space constraints, DBI’s draft policies will allow a building to be constructed that cannot operate as designed if the natural gas supply is removed. This will impose significant costs and disruption on the owners and occupants of the building, almost certainly by 2045, and quite possibly much earlier – meaning that San Francisco would be permitting use of scarce, valuable real estate for buildings that would have a life of less than 25 years before requiring major reconstruction.

Worse, there is no provision that prospective buyers or tenants be informed that in less than 25 years, building conversion will be expensive, disruptive, and may remove space the occupants are currently using of other purposes.

If the building cannot go all electric as designed (size, features) then perhaps that building should not be permitted. Is it worth building housing that will evict some occupants in less than 25 years?

There are several actions that you, as supervisors, can take to mitigate many of the problems:

- 1) Establish a public hearing process as part of the exceptions process, with a clear public interest requirement for any buildings where exceptions are granted and a clear process for future conversion to all electric is established.
- 2) Ensure that market forces encouraging all electric construction are leveraged, by requiring disclosure of the risks of future costs and disruption when purchasing a newly constructed mixed fuel building, costs that entail stranded assets as well as construction costs and possible loss of usable space.
- 3) Mandate a review and public hearings on San Francisco’s policies with respect to transformer siting. This should involve Public Works, Planning and DBI, with input from PG&E and CleanPower SF to clarify how grid modifications or different in-building electric infrastructure might resolve current constraints. Unfortunately, it appears that this will require

direction from the Board of Supervisors, as the agencies reporting to the Mayor have not recognized this need, choosing instead to double down on existing policies in their response to the June 30 draft.

I urge you to address these crucial issues.

Sincerely,

Paul Wermer

--

Paul Wermer
2309 California Street
San Francisco, CA 94115

[CA-BD] 3 Michelin Star restaurants with all-electric kitchens

Sean Armstrong <sean@redwoodenergy.net>

Sun, Sep 20, 2020 at 3:02 AM

To: CA Building Decarbonization <ca-building-decarbonization@googlegroups.com>, 100% Clean Energy <100-PERCENT-CLEAN-ENERGY@lists.sierraclub.org>

Hi Team!

For the City of San Mateo all-electric reach code hearing this week, I spent a few hours reviewing kitchen tours to confirm that there are lots of 3 Michelin Star all-electric restaurants world-wide. I have provided the best video evidence I found, but I always reviewed at least 3 videos to make sure I didn't miss anything. I was pleasantly surprised to find that almost every one I reviewed was all-electric--13 of the 16 I reviewed, out of a total [137 restaurants with 3 Michelin Stars](#).

- Les Prés d'Eugénie in the South of France has had 3 Michelin Stars since 1977, and has [an all-electric kitchen](#) (excepting the roasting spit in the open wood fireplace)
- The Le Louis XV in l'Hôtel de Paris (3 Stars) bills itself as the most exclusive restaurant in Europe and has [an all-electric](#) kitchen
- The Fat Duck (3 Stars) in Berkshire, England is has [a brand new all-electric kitchen](#) to accomplish its whimsical, narrative courses
- Maaemo, the only 3 Michelin Star restaurant in Norway, has an [all-electric kitchen](#) for it's incredible wild crafted mini-sculptures of ocean scenes
- Restaurant Amador in Vienna is Austria's only 3 Michelin Star restaurant and is all-electric, and the [many-times-over Michelin Star awarded chef Juan Amador](#) and proprietor has opened other [all-electric restaurant in Germany](#)
- Geranium, the only 3 Michelin Star restaurant in Denmark, has [an all-electric kitchen](#)
- Hof van Cleve, the only 3 Michelin Star restaurant in Belgium, has an [all-electric kitchen](#)
- Azurmendi of Larrabetzu, Spain (3 Stars) [is all-electric](#) and also bills itself as the most sustainable restaurant in the world
- Robuchon au Dôme in Macau (3 Stars) bills itself as one of the greatest restaurants in Asia and [is all-electric](#)
- The Restaurant de l'Hôtel de Ville (3 Stars) in Crissier, Switzerland is one of the finest classic-but-creative restaurants in Europe and has an all-electric kitchen.
- Both the French Laundry in Napa and Per Se in NYC [have 3 Michelin stars](#) and are led by chef Thomas Keller. Per Se is all-electric, which [you can see in this tour](#). The French Laundry's original kitchen still has gas, but the larger kitchen Thomas Keller custom-built in a new building for the French Laundry is all-electric. While both the old and new kitchens are used each night, Thomas Keller clearly prefers the new all-electric one in his tours because of the exacting control he has over temperatures when making [dishes](#) like [sous vide](#). Thomas Keller's 1 Michelin Star bistro, Bouchon, [is also all-electric](#).
- Alinea in Chicago (3 Stars) is all-electric. Lots of [fun video tours](#) of them in the kitchen blowing up balloons full of aromas for people to "eat" for desert. Again, extremely demanding requirements for temperature control.

While looking at other kitchen tours I happened upon La Terraza (only 1 Michelin Star) in the Hotel Eden in Rome, which was recently renovated and has [an all-electric kitchen](#).

So, hopefully this clearly illustrates that some, perhaps most, of the finest dining available in the world is performed in all-electric kitchens.

Warm regards,
Sean

--

**Managing Principal
Redwood Energy**

707.826.1450
[1887 Q Street](mailto:1887.Q@redwoodenergy.net)
[Arcata, CA 95521](mailto:1887.Q@redwoodenergy.net)
www.redwoodenergy.net

Grand Prize Winner of the United Nations World Habitat Awards-2017
Grand Prize Winner of the International PCBC Gold Nugget Awards-2016
Winner of the Sustainability Award of the Building Industry Association of Southern California-2017
Winner of the Department of Energy Innovation Award-2015 and 2020
Awards of Merit from the International PCBC Gold Nugget Awards-2016, 2017, 2018 and 2019

--

You received this message because you are subscribed to the Google Groups "CA Building Decarbonization" group.

To unsubscribe from this group and stop receiving emails from it, send an email to ca-building-decarbonization+unsubscribe@googlegroups.com.

To view this discussion on the web visit https://groups.google.com/d/msgid/ca-building-decarbonization/CAMr-5NwHc84F-RkP_oN0xXDqk_nkJxFMx1suNyxQ

From: [Liliana Peliks](#)
To: [Major, Erica \(BOS\)](#); [Board of Supervisors, \(BOS\)](#); [Preston, Dean \(BOS\)](#); [Peskin, Aaron \(BOS\)](#); [Safai, Ahsha \(BOS\)](#); [MandelmanStaff, \(BOS\)](#); [Ronen, Hillary](#)
Subject: Public Comment Re: BoS File 200701 (Item 1 of 9/21 Land Use)
Date: Monday, September 21, 2020 6:59:24 AM

This message is from outside the City email system. Do not open links or attachments from untrusted sources.

Land Use Committee, Board of Supervisors, and Sup. Ronen,

I'm a resident of San Francisco writing to strongly support prohibiting gas in new construction. The methane leaks, air pollution, and explosion dangers of natural gas are no longer necessary for the functioning of our homes and businesses. San Francisco can lead the state and the country in building a better future.

In addition to recommending the ordinance, I would also like to ask the Commission to recommend the changes to the ordinance as laid out by Earthjustice, the Sierra Club, the San Francisco Climate Emergency Coalition, and other local groups in their letter to the Commission and Board.

It is important to me that we:

1. Eliminate the feasibility exception to the electric-ready requirement and make fully electric-ready construction a baseline requirement for new construction. We know that the future is electric. Allowing any building to be built that will require massive retrofits in the near future is unacceptable. With full electric readiness, we minimize that retrofit cost.
2. Create a Clean Energy Building Hub through the City and County of San Francisco that provides for the outreach, resources, and education needed to eliminate barriers and maximize opportunity for all-electric new construction to benefit both climate and equity.
3. Expand the ordinance's definition of "mixed-fuel buildings" to include laboratory, industrial, and decorative uses of gas. Gas shouldn't be allowed for upscale decorative uses. It's wrong to harm public health for private enjoyment.
4. Provide additional limitations and transparency in the exemption process to ensure any project found exempt for infeasibility is truly in the public interest. I'm concerned about the news of powerful and connected people being able to get favors from DBI. We need sunshine on the exemption process, and exemptions should only be given in the public interest.
5. Amend section 106A.1.17 to require that the Building Official find "sufficient evidence was submitted to substantiate the infeasibility of an All-Electric Building or Project design without regard to financial, floor-area, or amenity-related loss unless deemed to be in the public welfare." The housing crisis is real. And we need to find ways of fixing it without sacrificing our children's future. The space taken up by a transformer should not be an acceptable reason for

an exemption.

6. Eliminate the blanket exemption for commercial kitchens delaying compliance until 2022. Existing restaurants are not helped by giving builders a pass on making future commercial kitchens all-electric.

Thank you for taking up this important issue and considering the health and safety of our residents and climate.

Liliana Peliks

lilianalmatos@gmail.com

725 Banks Street

San Francisco, California 94110

From: [Diane Bailey](#)
To: [Major, Erica \(BOS\)](#)
Cc: [Peskin, Aaron \(BOS\)](#); [Hepner, Lee \(BOS\)](#); [Safai, Ahsha \(BOS\)](#); [Sandoval, Suhagey \(BOS\)](#); [Preston, Dean \(BOS\)](#); [Smeallie, Kyle \(BOS\)](#); [MandelmanStaff, \[BOS\]](#); [Bintliff, Jacob \(BOS\)](#); [Raphael, Deborah \(ENV\)](#); [Board of Supervisors, \(BOS\)](#)
Subject: Public Comment in support of: All-Electric New Construction Ordinance (File 200701)
Date: Sunday, September 20, 2020 11:52:57 PM
Attachments: [image001.png](#)

This message is from outside the City email system. Do not open links or attachments from untrusted sources.

Dear Supervisors,

On behalf of the Campaign for Fossil Free Buildings in Silicon Valley (FFBSV), this letter expresses our strong support for the All-Electric New Construction Ordinance in San Francisco. Although we are in unprecedented times with a pandemic and economic downturn, city building electrification regulations are critically needed to address the magnitude of the climate, air quality, health, and safety impacts of current fossil gas use in our homes and buildings.

FFBSV includes the 33 organizations working together to support an accelerated phase out of fossil fuels in buildings.^[i] A rapid transition away from fossil fuel use is critical to avoid the very worst and irreversible impacts of climate change. Preventing the use of fossil fuels, including natural gas, in new construction will create more affordable, cleaner, healthier, and more resilient housing and buildings for communities throughout San Francisco.

Building Electrification is an Urgent Climate Action

The recent extreme heat, unusual lightning activity, reduced marine layer, and unprecedented wildfire activity are all hallmarks of climate destabilization that we are experiencing. The depth of the climate crisis is worse than commonly understood and demands urgent action. In addition to sobering current conditions and devastating long-term climate consequences, Redwood City faces significant near-term risks of flooding from sea level rise and inundation of entire neighborhoods. In 2018, the Intergovernmental Panel on Climate Change (IPCC) concluded that ***we must dramatically reduce Greenhouse Gas (GHG) emissions by 2030***

through rapid, far-reaching, and unprecedented measures.^[ii] Since that report was issued, we have seen greater impacts from climate change than anticipated.^[iii] Current trends for carbon emissions and lack of action show that we are headed to *twice* the rate of warming that the Paris Climate Accord sought to contain.

We recommend the following improvements to the ordinance:

1. Please make electric-ready required for all buildings granted an exemption;
2. Please include laboratory and industrial uses in the prohibited uses of natural gas;

3. Please create a clean energy building hub to coordinate resources and training;
4. Please add a public interest exception and more public oversight and visibility into exemptions; and
5. Please eliminate the waiver for restaurants.

Over a dozen local cities have adopted all-electric requirements for new construction that avoid new Fossil Gas use because there are many benefits to community health, safety, and a stable climate future, including:

- **Economic:** All-electric homes are less expensive to build (saving roughly \$3,000 or more for each new apartment unit, for example). In all of the buildings analyzed by the 2019 Nonresidential New Construction Reach Code Cost Effectiveness Study, all-electric versions cost less to construct than their mixed-fuel counterparts. **All-Electric buildings are also more efficient.** For example, according to the California Energy Commission, a modern high efficiency heat pump electric water heater (available now at major retailers) costs roughly one third less on utility bills to operate than the most efficient gas water heater. ^[iv] In addition, all-electric buildings include air conditioning combined with heating, resulting in less equipment, reduced maintenance costs and greater climate resilience.
- **Public Safety:** Natural gas is highly flammable. In the past ten years, 9,000 gas explosions in the U.S have killed over 500 people, and gas leaks have displaced and sickened thousands of people. ^[v] Fossil Gas also caused half the fires after two major California earthquakes. ^[vi]
- **Public Health:** Gas stoves release smog-forming compounds such as nitrogen dioxide, unburnt hydrocarbons and carbon monoxide pollution that doubles risks for heart and lung disease and triples the use of asthma medications. ^[vii] ***In fact, studies have shown that children living in homes using gas for cooking have a more than 40% higher risk of having asthma.*** ^[viii] Further, improperly vented gas appliances lead to carbon monoxide poisoning that results in thousands of emergency room visits and several hundred deaths every year. ^[ix]
- **Climate:** All-electric buildings are a highly visible and practical step forward to address the climate crisis, by breaking the cycle of fossil fuel dependency in buildings. According to the GHG inventory, natural gas usage in Redwood City buildings accounts for 45% of the GHGs generated in the city. This is the single biggest step that cities can take to address climate this year.
- **Construction Time Savings:** All-electric buildings are generally faster to design, permit, and build. The code is easier for building and planning staff to apply, and it is also easier for everyone to understand.
- **Resilience:** All-electric code today prevents a complex, costly and likely inevitable switch to electricity in the future, since gas prices are expected to rise sharply, and California is planning to eventually end gas distribution. PG&E has asked for a 24% gas rate increase and SoCalGas, a 42% increase, over the next couple years, and this is just the beginning. **Building all-electric now will help future-proof San Francisco.**

For all of these reasons stated above, **we respectfully ask that the recommendations above be considered and above all else, urge you to vote yes for this important all-electric new construction ordinance.** Thank you for considering our comments.

Sincerely,
Diane Bailey, on behalf of the Campaign for Fossil Free Buildings in Silicon Valley

Diane Bailey | Executive Director

MENLO SPARK

diane@menlospark.org | 650-281-7073

Visit us: www.MenloSpark.org & www.FossilFreeBuildings.org

Find us on [Facebook](#)

Follow us on [Twitter](#)



Climate Neutral for a Healthy, Prosperous Menlo Park

EV, PV & Fossil Free: Guides for Electric Cars, solar & Fossil Free Homes at: <http://menlospark.org/what-we-do/>

[i] Learn more about the FFBSV Campaign and find resources at www.FossilFreeBuildings.org

[ii] <https://www.ipcc.ch/sr15/>. Also see: WRI blog for a roundup of the landmark reports of 2018 & a comparison of climate impacts in a 1.5 deg.C v. 2 deg.C world: <https://www.wri.org/blog/2018/12/2018-year-climate-extremes>

[iii] For example, the 2019-2020 Australian wildfire that destroyed over 10,000 buildings and killed at least 34 people, and a massive global bleaching event for coral reefs impacting hundreds of millions of low income people who rely on fisheries for their food or livelihoods.

See: A roundup on the latest global reports showing a worsened outlook than previously understood, including an estimated 3-5 degrees C of likely warming by the end of the century, [here](#):

https://docs.google.com/document/d/1-LHZe9kFhLymXE7CaVZmgQTx8VEfbGKAVOSK_x4TcDo/edit?usp=sharing

This WRI blog discusses the state of international climate negotiations as of COP25 and what is required moving ahead:

<https://www.wri.org/blog/2019/12/cop25-what-we-needed-what-we-got-whats-next>

This NYT OpEd discusses why climate action is essential in the midst of the COVID-19 pandemic and how to integrate a climate response into the economic recovery required: <https://www.nytimes.com/2020/04/15/opinion/climate-change-covid-economy.html?smid=em-share>

[iv] Rider, Ken, Email correspondence, ken.rider@energy.ca.gov. March 2020.

[v] Joseph, George. "30 Years of Oil and Gas Pipeline Accidents, Mapped." Citylab. November 30, 2016

Sellers, F., Weintraub, K. and Wootson, C. (2018). "Thousands of residents still out of their homes after gas explosions trigger deadly chaos in Massachusetts." Washington Post. https://www.washingtonpost.com/national/thousands-of-residents-still-out-of-their-homes-after-gas-explosions-trigger-deadly-chaos-in-massachusetts/2018/09/14/802ff690-b830-11e8-94eb-3bd52dfe917b_story.html

[vi] Los Angeles in 1994 and San Francisco in 1989, according to the California Seismic Safety Commission. (2002). "Improving Natural Gas Safety in Earthquakes." SSC-02-03

Taylor, Ann. "The Northridge Earthquake: 20 Years Ago Today." The Atlantic. January 17, 2014.

[vii]

Jarvis et al. (1996) "Evaluation of asthma prescription measures and health system performance based on emergency department utilization." <https://www.ncbi.nlm.nih.gov/pubmed/8618483>

[viii]

Lin, W., Brunekreef, B. & Gehring, U. Meta-analysis of the effects of indoor nitrogen dioxide and gas cooking on asthma and wheeze in children. *Int. J. Epidemiol.* 42, 1724–1737 (2013).

[ix]

USDN, Methane Math, https://sfenvironment.org/sites/default/files/fliers/files/methane-math_natural-gas-report_final.pdf

From: [Donna Benedetti](#)
To: [Major, Erica \(BOS\)](#); [Board of Supervisors, \(BOS\)](#); [Preston, Dean \(BOS\)](#); [Peskin, Aaron \(BOS\)](#); [Safai, Ahsha \(BOS\)](#); [MandelmanStaff, \[BOS\]](#)
Subject: Public Comment Re: BoS File 200701 (Item 1 of 9/21 Land Use)
Date: Sunday, September 20, 2020 11:39:03 PM

This message is from outside the City email system. Do not open links or attachments from untrusted sources.

Land Use Committee, Board of Supervisors, and Sup. Preston,

I'm a resident of San Francisco District 5 writing to strongly support prohibiting natural gas in new construction.

San Francisco prides itself on being a leader in improving the health and safety of all her residents. The use of natural gas is antithetical to our well-being. Methane leaks, air pollution, and explosion dangers of natural gas are no longer necessary for the functioning of our homes and businesses.

Now is the time for all of us--and especially our elected officials--to take a courageous stand and vote to end our reliance on environmentally hazardous natural gas in all new buildings.

In addition to recommending the ordinance, I would also like to ask the Commission to recommend the changes to the ordinance as laid out by Earthjustice, the Sierra Club, the San Francisco Climate Emergency Coalition, and other local groups in their letter to the Commission and Board.

It is important to me that we:

1. Eliminate the feasibility exception to the electric-ready requirement and make fully electric-ready construction a baseline requirement for new construction. We know that the future is electric. Allowing any building to be built that will require massive retrofits in the near future is unacceptable. With full electric readiness, we minimize that retrofit cost.
2. Create a Clean Energy Building Hub through the City and County of San Francisco that provides for the outreach, resources, and education needed to eliminate barriers and maximize opportunity for all-electric new construction to benefit both climate and equity.
3. Expand the ordinance's definition of "mixed-fuel buildings" to include laboratory, industrial, and decorative uses of gas. Gas shouldn't be allowed for upscale decorative uses. It's wrong to harm public health for private enjoyment.
4. Provide additional limitations and transparency in the exemption process to ensure any project found exempt for infeasibility is truly in the public interest. I'm concerned about the news of powerful and connected people being able to get favors from DBI. We need sunshine on the exemption process, and exemptions should only be given in the public interest.

5. Amend section 106A.1.17 to require that the Building Official find "sufficient evidence was submitted to substantiate the infeasibility of an All-Electric Building or Project design without regard to financial, floor-area, or amenity-related loss unless deemed to be in the public welfare." The housing crisis is real. And we need to find ways of fixing it without sacrificing our children's future. The space taken up by a transformer should not be an acceptable reason for an exemption.

6. Eliminate the blanket exemption for commercial kitchens delaying compliance until 2022. Existing restaurants are not helped by giving builders a pass on making future commercial kitchens all-electric.

Thank you for taking up this important issue and considering the health and safety of our residents and climate.

Donna Benedetti
donna jean720@sbcglobal.net
720 Gough Street #33
San Francisco, California 94102

From: [Erika Reinhardt](#)
To: [Major, Erica \(BOS\)](#); [Board of Supervisors, \(BOS\)](#); [Preston, Dean \(BOS\)](#); [Peskin, Aaron \(BOS\)](#); [Safai, Ahsha \(BOS\)](#); [MandelmanStaff, \(BOS\)](#); [Haney, Matt \(BOS\)](#)
Subject: Public Comment Re: BoS File 200701 (Item 1 of 9/21 Land Use)
Date: Sunday, September 20, 2020 9:34:16 PM

This message is from outside the City email system. Do not open links or attachments from untrusted sources.

Land Use Committee, Board of Supervisors, and Sup. Haney,

I'm a resident of San Francisco in District 7, writing to strongly support prohibiting gas in new construction. It's beyond time that we act on the many dangers to human life and well-being that relying on natural gas in our buildings pose — from indoor air pollution and climate change, to explosion and fire-risks. I'm thrilled for the possibility of San Francisco earnestly becoming a leader here, for the benefit of all residents.

As the mother of a now pre-asthmatic toddler after unknowingly exposing him to the dangers of gas stove cooking, the impacts here are known and personal, and not at all hypothetical. It's tragic that that same story, and much worse, is repeated thousands of times just in our city.

In addition to strongly recommending that the ordinance be passed quickly in order to take effect as soon as possible, I would also like to ask the Commission to recommend the changes to the ordinance as laid out by Earthjustice, the Sierra Club, the San Francisco Climate Emergency Coalition, and other local groups in their letter to the Commission and Board.

It is important to me that we:

1. Eliminate the feasibility exception to the electric-ready requirement and make fully electric-ready construction a baseline requirement for new construction. We know that the future is electric. Allowing any building to be built that will require massive retrofits in the near future is unacceptable. With full electric readiness, we minimize that retrofit cost.
2. Create a Clean Energy Building Hub through the City and County of San Francisco that provides for the outreach, resources, and education needed to eliminate barriers and maximize opportunity for all-electric new construction to benefit both climate and equity.
3. Expand the ordinance's definition of "mixed-fuel buildings" to include laboratory, industrial, and decorative uses of gas. Gas shouldn't be allowed for upscale decorative uses. It's wrong to harm public health for private enjoyment.
4. Provide additional limitations and transparency in the exemption process to ensure any project found exempt for infeasibility is truly in the public interest. I'm concerned about the news of powerful and connected people being able to get favors from DBI. We need sunshine on the exemption process, and exemptions should only be given in the public interest.

5. Amend section 106A.1.17 to require that the Building Official find "sufficient evidence was submitted to substantiate the infeasibility of an All-Electric Building or Project design without regard to financial, floor-area, or amenity-related loss unless deemed to be in the public welfare." The housing crisis is real. And we need to find ways of fixing it without sacrificing our children's future. The space taken up by a transformer should not be an acceptable reason for an exemption.

6. Eliminate the blanket exemption for commercial kitchens delaying compliance until 2022. Existing restaurants are not helped by giving builders a pass on making future commercial kitchens all-electric.

Thank you for taking up this important issue and considering the health and safety of our residents and climate.

Erika Reinhardt
embreinhardt@gmail.com
182 Howard St, #150
San Francisco, California 94105

From: [Vicky Zhang](#)
To: [Major, Erica \(BOS\)](#); [Board of Supervisors, \(BOS\)](#); [Preston, Dean \(BOS\)](#); [Peskin, Aaron \(BOS\)](#); [Safai, Ahsha \(BOS\)](#); [MandelmanStaff, \[BOS\]](#)
Subject: Public Comment Re: BoS File 200701 (Item 1 of 9/21 Land Use)
Date: Sunday, September 20, 2020 9:02:13 PM

This message is from outside the City email system. Do not open links or attachments from untrusted sources.

Land Use Committee, Board of Supervisors, and Sup. Mandelman,

I'm a resident of San Francisco District 8 writing to strongly support prohibiting gas in new construction. The methane leaks, air pollution, and explosion dangers of natural gas are no longer necessary for the functioning of our homes and businesses. San Francisco can lead the state and the country in building a better future.

In addition to recommending the ordinance, I would also like to ask the Commission to recommend the changes to the ordinance as laid out by Earthjustice, the Sierra Club, the San Francisco Climate Emergency Coalition, and other local groups in their letter to the Commission and Board.

It is important to me that we:

1. Eliminate the feasibility exception to the electric-ready requirement and make fully electric-ready construction a baseline requirement for new construction. We know that the future is electric. Allowing any building to be built that will require massive retrofits in the near future is unacceptable. With full electric readiness, we minimize that retrofit cost.
2. Create a Clean Energy Building Hub through the City and County of San Francisco that provides for the outreach, resources, and education needed to eliminate barriers and maximize opportunity for all-electric new construction to benefit both climate and equity.
3. Expand the ordinance's definition of "mixed-fuel buildings" to include laboratory, industrial, and decorative uses of gas. Gas shouldn't be allowed for upscale decorative uses. It's wrong to harm public health for private enjoyment.
4. Provide additional limitations and transparency in the exemption process to ensure any project found exempt for infeasibility is truly in the public interest. I'm concerned about the news of powerful and connected people being able to get favors from DBI. We need sunshine on the exemption process, and exemptions should only be given in the public interest.
5. Amend section 106A.1.17 to require that the Building Official find "sufficient evidence was submitted to substantiate the infeasibility of an All-Electric Building or Project design without regard to financial, floor-area, or amenity-related loss unless deemed to be in the public welfare." The housing crisis is real. And we need to find ways of fixing it without sacrificing our children's future. The space taken up by a transformer should not be an acceptable reason for

an exemption.

6. Eliminate the blanket exemption for commercial kitchens delaying compliance until 2022. Existing restaurants are not helped by giving builders a pass on making future commercial kitchens all-electric.

Thank you for taking up this important issue and considering the health and safety of our residents and climate.

Vicky Zhang

vicky11zhang@gmail.com

3861 23rd Street

SAN FRANCISCO, California 94114

From: [Margaret Chen](#)
To: [Major, Erica \(BOS\)](#)
Subject: electrification
Date: Sunday, September 20, 2020 8:29:47 PM

This message is from outside the City email system. Do not open links or attachments from untrusted sources.

As a resident of SF and physician, I would like to add a health perspective to your consideration of Supervisor Mandelman's proposed ordinance to amend the building code to require that new construction be all electric. The health benefits would be substantial, and would arise from improved air quality and decreased emissions of greenhouse gases carbon dioxide and methane.

1. Air quality and health impacts.

I would like to call your attention to some key findings of the 2020 UCLA Fielding School of Public Health study, [Effects of Residential Gas Appliances on Indoor and Outdoor Air Quality and Public Health in California](#).

Indoor air quality findings included:

- Gas appliances emit a wide range of air pollutants, such as carbon monoxide (CO), nitrogen oxides (NOx, including nitrogen dioxide (NO2)), particulate matter (PM), and formaldehyde, which have been linked to various acute and chronic health effects, including respiratory illness, cardiovascular disease, and premature death .
- Under a hypothetical cooking scenario where a stove and oven are used simultaneously for 1 hour, peak concentrations of NO2 from cooking with gas appliances exceed the levels of acute national and California-based ambient air quality thresholds in more than 90% of modeled emission scenarios . Concentrations of CO and NO2 resulting from gas cooking are the highest for apartments, due to a smaller residence size . This presents an additional risk for renters, who are often low-income .
- The use of kitchen appliances for supplemental heating can increase exposure risks, and there is evidence this disproportionately affects low-income households, though more data on the frequency of use is needed to quantify the risk to various populations .
- Outdoor air quality findings included:
 - Gas appliances are also a source of outdoor air pollution, and literature shows that the pollutants released by combustion can lead to illness and premature death

From: [Margie Chen](#)
To: [Major, Erica \(BOS\)](#); [Board of Supervisors, \(BOS\)](#); [Preston, Dean \(BOS\)](#); [Peskin, Aaron \(BOS\)](#); [Safai, Ahsha \(BOS\)](#); [MandelmanStaff, \(BOS\)](#); [Stefani, Catherine \(BOS\)](#)
Subject: Public Comment Re: BoS File 200701 (Item 1 of 9/21 Land Use)
Date: Sunday, September 20, 2020 8:25:38 PM

This message is from outside the City email system. Do not open links or attachments from untrusted sources.

Land Use Committee, Board of Supervisors, and Sup. Stefani,

I'm a resident of San Francisco writing to strongly support prohibiting gas in new construction. The methane leaks, air pollution, and explosion dangers of natural gas are no longer necessary for the functioning of our homes and businesses. San Francisco can lead the state and the country in building a better future.

In addition to recommending the ordinance, I would also like to ask the Commission to recommend the changes to the ordinance as laid out by Earthjustice, the Sierra Club, the San Francisco Climate Emergency Coalition, and other local groups in their letter to the Commission and Board.

It is important to me that we:

1. Eliminate the feasibility exception to the electric-ready requirement and make fully electric-ready construction a baseline requirement for new construction. We know that the future is electric. Allowing any building to be built that will require massive retrofits in the near future is unacceptable. With full electric readiness, we minimize that retrofit cost.
2. Create a Clean Energy Building Hub through the City and County of San Francisco that provides for the outreach, resources, and education needed to eliminate barriers and maximize opportunity for all-electric new construction to benefit both climate and equity.
3. Expand the ordinance's definition of "mixed-fuel buildings" to include laboratory, industrial, and decorative uses of gas. Gas shouldn't be allowed for upscale decorative uses. It's wrong to harm public health for private enjoyment.
4. Provide additional limitations and transparency in the exemption process to ensure any project found exempt for infeasibility is truly in the public interest. I'm concerned about the news of powerful and connected people being able to get favors from DBI. We need sunshine on the exemption process, and exemptions should only be given in the public interest.
5. Amend section 106A.1.17 to require that the Building Official find "sufficient evidence was submitted to substantiate the infeasibility of an All-Electric Building or Project design without regard to financial, floor-area, or amenity-related loss unless deemed to be in the public welfare." The housing crisis is real. And we need to find ways of fixing it without sacrificing our children's future. The space taken up by a transformer should not be an acceptable reason for

an exemption.

6. Eliminate the blanket exemption for commercial kitchens delaying compliance until 2022. Existing restaurants are not helped by giving builders a pass on making future commercial kitchens all-electric.

Thank you for taking up this important issue and considering the health and safety of our residents and climate.

Margie Chen
paredocs@gmail.com
2722 Green St
San Francisco, California 94123

From: [Hilary Karls](#)
To: [Major, Erica \(BOS\)](#)
Cc: [Preston, Dean \(BOS\)](#)
Subject: Public Comment Re: BoS File 200701
Date: Sunday, September 20, 2020 4:57:40 PM

This message is from outside the City email system. Do not open links or attachments from untrusted sources.

Good afternoon Ms Major and Mr Preston,

I'm a 15 year resident of San Francisco writing to strongly support prohibiting gas in new construction, particularly remembering the San Bruno fire a little over 10 years ago. The methane leaks, air pollution, and explosion dangers of natural gas are no longer necessary for the functioning of our homes and businesses. San Francisco can lead the state and the country in building a better future.

In addition to recommending the ordinance, I would also like to ask the Commission to recommend the changes to the ordinance as laid out by Earthjustice, the Sierra Club, the San Francisco Climate Emergency Coalition, and other local groups in their letter to the Commission and Board.

It is important to me that we:

1. Eliminate the feasibility exception to the electric-ready requirement and make fully electric-ready construction a baseline requirement for new construction. We know that the future is electric. Allowing any building to be built that will require massive retrofits in the near future is unacceptable. With full electric readiness, we minimize that retrofit cost.
2. Create a Clean Energy Building Hub through the City and County of San Francisco that provides for the outreach, resources, and education needed to eliminate barriers and maximize opportunity for all-electric new construction to benefit both climate and equity.
3. Expand the ordinance's definition of "mixed-fuel buildings" to include laboratory, industrial, and decorative uses of gas. Gas shouldn't be allowed for upscale decorative uses. It's wrong to harm public health for private enjoyment.
4. Provide additional limitations and transparency in the exemption process to ensure any project found exempt for infeasibility is truly in the public interest. I'm concerned about the news of powerful and connected people being able to get favors from DBI. We need sunshine on the exemption process, and exemptions should only be given in the public interest.
5. Amend section 106A.1.17 to require that the Building Official find "sufficient evidence was submitted to substantiate the infeasibility of an All-Electric Building or Project design without regard to financial, floor-area, or amenity-related loss unless deemed to be in the public welfare." The housing crisis is real. And we need to find ways of fixing it without sacrificing our children's future. The space taken up by a transformer should not be an acceptable reason for an exemption.

6. Eliminate the blanket exemption for commercial kitchens delaying compliance until 2022. Existing restaurants are not helped by giving builders a pass on making future commercial kitchens all-electric.

Thank you for taking up this important issue and considering the health and safety of our residents and climate.

Sincerely,

Hilary Karls

221 Downey St #2

94117

From: [Aaron Goodman](#)
To: [Major, Erica \(BOS\)](#); [Board of Supervisors, \(BOS\)](#); [Preston, Dean \(BOS\)](#); [Peskin, Aaron \(BOS\)](#); [Safai, Ahsha \(BOS\)](#); [MandelmanStaff, \[BOS\]](#)
Subject: Public Comment Re: BoS File 200701 (Item 1 of 9/21 Land Use)
Date: Sunday, September 20, 2020 4:06:08 PM

This message is from outside the City email system. Do not open links or attachments from untrusted sources.

Land Use Committee, Board of Supervisors, and Sup. Safai,

I'm a resident of San Francisco writing to strongly support prohibiting gas in new construction. The methane leaks, air pollution, and explosion dangers of natural gas are no longer necessary for the functioning of our homes and businesses. San Francisco can lead the state and the country in building a better future.

In addition to recommending the ordinance, I would also like to ask the Commission to recommend the changes to the ordinance as laid out by Earthjustice, the Sierra Club, the San Francisco Climate Emergency Coalition, and other local groups in their letter to the Commission and Board.

It is important to me that we:

1. Eliminate the feasibility exception to the electric-ready requirement and make fully electric-ready construction a baseline requirement for new construction. We know that the future is electric. Allowing any building to be built that will require massive retrofits in the near future is unacceptable. With full electric readiness, we minimize that retrofit cost.
2. Create a Clean Energy Building Hub through the City and County of San Francisco that provides for the outreach, resources, and education needed to eliminate barriers and maximize opportunity for all-electric new construction to benefit both climate and equity.
3. Expand the ordinance's definition of "mixed-fuel buildings" to include laboratory, industrial, and decorative uses of gas. Gas shouldn't be allowed for upscale decorative uses. It's wrong to harm public health for private enjoyment.
4. Provide additional limitations and transparency in the exemption process to ensure any project found exempt for infeasibility is truly in the public interest. I'm concerned about the news of powerful and connected people being able to get favors from DBI. We need sunshine on the exemption process, and exemptions should only be given in the public interest.
5. Amend section 106A.1.17 to require that the Building Official find "sufficient evidence was submitted to substantiate the infeasibility of an All-Electric Building or Project design without regard to financial, floor-area, or amenity-related loss unless deemed to be in the public welfare." The housing crisis is real. And we need to find ways of fixing it without sacrificing our children's future. The space taken up by a transformer should not be an acceptable reason for

an exemption.

6. Eliminate the blanket exemption for commercial kitchens delaying compliance until 2022. Existing restaurants are not helped by giving builders a pass on making future commercial kitchens all-electric.

Thank you for taking up this important issue and considering the health and safety of our residents and climate.

Aaron Goodman D11

Aaron Goodman
amgodman@yahoo.com
25 Lisbon St.
San Francisco , California 94112

From: [Christine Strohl](#)
To: [Major, Erica \(BOS\)](#); [Board of Supervisors, \(BOS\)](#); [Preston, Dean \(BOS\)](#); [Peskin, Aaron \(BOS\)](#); [Safai, Ahsha \(BOS\)](#); [MandelmanStaff, \(BOS\)](#); [Ronen, Hillary](#)
Subject: Public Comment Re: BoS File 200701 (Item 1 of 9/21 Land Use)
Date: Sunday, September 20, 2020 3:01:31 PM

This message is from outside the City email system. Do not open links or attachments from untrusted sources.

Land Use Committee, Board of Supervisors, and Sup. Ronen,

I'm a resident of San Francisco writing to strongly support prohibiting gas in new construction. The methane leaks, air pollution, and explosion dangers of natural gas are no longer necessary for the functioning of our homes and businesses. San Francisco can lead the state and the country in building a better future.

In addition to recommending the ordinance, I would also like to ask the Commission to recommend the changes to the ordinance as laid out by Earthjustice, the Sierra Club, the San Francisco Climate Emergency Coalition, and other local groups in their letter to the Commission and Board.

It is important to me that we:

1. Eliminate the feasibility exception to the electric-ready requirement and make fully electric-ready construction a baseline requirement for new construction. We know that the future is electric. Allowing any building to be built that will require massive retrofits in the near future is unacceptable. With full electric readiness, we minimize that retrofit cost.
2. Create a Clean Energy Building Hub through the City and County of San Francisco that provides for the outreach, resources, and education needed to eliminate barriers and maximize opportunity for all-electric new construction to benefit both climate and equity.
3. Expand the ordinance's definition of "mixed-fuel buildings" to include laboratory, industrial, and decorative uses of gas. Gas shouldn't be allowed for upscale decorative uses. It's wrong to harm public health for private enjoyment.
4. Provide additional limitations and transparency in the exemption process to ensure any project found exempt for infeasibility is truly in the public interest. I'm concerned about the news of powerful and connected people being able to get favors from DBI. We need sunshine on the exemption process, and exemptions should only be given in the public interest.
5. Amend section 106A.1.17 to require that the Building Official find "sufficient evidence was submitted to substantiate the infeasibility of an All-Electric Building or Project design without regard to financial, floor-area, or amenity-related loss unless deemed to be in the public welfare." The housing crisis is real. And we need to find ways of fixing it without sacrificing our children's future. The space taken up by a transformer should not be an acceptable reason for

an exemption.

6. Eliminate the blanket exemption for commercial kitchens delaying compliance until 2022. Existing restaurants are not helped by giving builders a pass on making future commercial kitchens all-electric.

Thank you for taking up this important issue and considering the health and safety of our residents and climate.

Christine Strohl
ccelic@gmail.com
357 Moultrie Street
san francisco, California 94110

From: [Glynis Nakahara](#)
To: [Major, Erica \(BOS\)](#); [Board of Supervisors, \(BOS\)](#); [Preston, Dean \(BOS\)](#); [Peskin, Aaron \(BOS\)](#); [Safai, Ahsha \(BOS\)](#); [MandelmanStaff, \(BOS\)](#); [Yee, Norman \(BOS\)](#)
Subject: Public Comment Re: BoS File 200701 (Item 1 of 9/21 Land Use)
Date: Sunday, September 20, 2020 2:59:09 PM

This message is from outside the City email system. Do not open links or attachments from untrusted sources.

Land Use Committee, Board of Supervisors, and Sup. Yee,

I'm a resident of San Francisco writing to strongly support prohibiting gas in new construction. The methane leaks, air pollution, and explosion dangers of natural gas are no longer necessary for the functioning of our homes and businesses. San Francisco can lead the state and the country in building a better future.

In addition to recommending the ordinance, I would also like to ask the Commission to recommend the changes to the ordinance as laid out by Earthjustice, the Sierra Club, the San Francisco Climate Emergency Coalition, and other local groups in their letter to the Commission and Board.

It is important to me that we:

1. Eliminate the feasibility exception to the electric-ready requirement and make fully electric-ready construction a baseline requirement for new construction. We know that the future is electric. Allowing any building to be built that will require massive retrofits in the near future is unacceptable. With full electric readiness, we minimize that retrofit cost.
2. Create a Clean Energy Building Hub through the City and County of San Francisco that provides for the outreach, resources, and education needed to eliminate barriers and maximize opportunity for all-electric new construction to benefit both climate and equity.
3. Expand the ordinance's definition of "mixed-fuel buildings" to include laboratory, industrial, and decorative uses of gas. Gas shouldn't be allowed for upscale decorative uses. It's wrong to harm public health for private enjoyment.
4. Provide additional limitations and transparency in the exemption process to ensure any project found exempt for infeasibility is truly in the public interest. I'm concerned about the news of powerful and connected people being able to get favors from DBI. We need sunshine on the exemption process, and exemptions should only be given in the public interest.
5. Amend section 106A.1.17 to require that the Building Official find "sufficient evidence was submitted to substantiate the infeasibility of an All-Electric Building or Project design without regard to financial, floor-area, or amenity-related loss unless deemed to be in the public welfare." The housing crisis is real. And we need to find ways of fixing it without sacrificing our children's future. The space taken up by a transformer should not be an acceptable reason for

an exemption.

6. Eliminate the blanket exemption for commercial kitchens delaying compliance until 2022. Existing restaurants are not helped by giving builders a pass on making future commercial kitchens all-electric.

Thank you for taking up this important issue and considering the health and safety of our residents and climate.

Glynis Nakahara
gnakahara@yahoo.com
10 Cerritos Avenue
San Francisco, California 94127

From: [Amy Lyden](#)
To: [Major, Erica \(BOS\)](#); [Board of Supervisors, \(BOS\)](#); [Preston, Dean \(BOS\)](#); [Peskin, Aaron \(BOS\)](#); [Safai, Ahsha \(BOS\)](#); [MandelmanStaff, \[BOS\]](#)
Subject: Public Comment Re: BoS File 200701 (Item 1 of 9/21 Land Use)
Date: Sunday, September 20, 2020 10:21:43 AM

This message is from outside the City email system. Do not open links or attachments from untrusted sources.

Land Use Committee, Board of Supervisors, and Sup. Mandelman,

I'm a resident of San Francisco in District 8 writing to strongly support prohibiting gas in new construction. The methane leaks, air pollution, and explosion dangers of natural gas are no longer necessary for the functioning of our homes and businesses. San Francisco can lead the state and the country in building a better future.

In addition to recommending the ordinance, I would also like to ask the Commission to recommend the changes to the ordinance as laid out by Earthjustice, the Sierra Club, the San Francisco Climate Emergency Coalition, and other local groups in their letter to the Commission and Board.

It is important to me that we:

1. Eliminate the feasibility exception to the electric-ready requirement and make fully electric-ready construction a baseline requirement for new construction. We know that the future is electric. Allowing any building to be built that will require massive retrofits in the near future is unacceptable. With full electric readiness, we minimize that retrofit cost.
2. Create a Clean Energy Building Hub through the City and County of San Francisco that provides for the outreach, resources, and education needed to eliminate barriers and maximize opportunity for all-electric new construction to benefit both climate and equity.
3. Expand the ordinance's definition of "mixed-fuel buildings" to include laboratory, industrial, and decorative uses of gas. Gas shouldn't be allowed for upscale decorative uses. It's wrong to harm public health for private enjoyment.
4. Provide additional limitations and transparency in the exemption process to ensure any project found exempt for infeasibility is truly in the public interest. I'm concerned about the news of powerful and connected people being able to get favors from DBI. We need sunshine on the exemption process, and exemptions should only be given in the public interest.
5. Amend section 106A.1.17 to require that the Building Official find "sufficient evidence was submitted to substantiate the infeasibility of an All-Electric Building or Project design without regard to financial, floor-area, or amenity-related loss unless deemed to be in the public welfare." The housing crisis is real. And we need to find ways of fixing it without sacrificing our children's future. The space taken up by a transformer should not be an acceptable reason for

an exemption.

6. Eliminate the blanket exemption for commercial kitchens delaying compliance until 2022. Existing restaurants are not helped by giving builders a pass on making future commercial kitchens all-electric.

Thank you for taking up this important issue and considering the health and safety of our residents and climate.

Amy Lyden

amy.m.lyden@gmail.com

466 14th St, APT 8

San Francisco, California 94103

From: beverlyjmccallister@hotmail.com
To: [Major, Erica \(BOS\)](#); [Board of Supervisors, \(BOS\)](#); [Preston, Dean \(BOS\)](#); [Peskin, Aaron \(BOS\)](#); [Safai, Ahsha \(BOS\)](#); [MandelmanStaff, \(BOS\)](#); [Stefani, Catherine \(BOS\)](#)
Subject: Public Comment Re: BoS File 200701 (Item 1 of 9/21 Land Use)
Date: Saturday, September 19, 2020 3:34:37 PM

This message is from outside the City email system. Do not open links or attachments from untrusted sources.

Land Use Committee, Board of Supervisors, and Sup. Stefani,

I'm a resident of San Francisco writing to strongly support prohibiting gas in new construction. The methane leaks, air pollution, and explosion dangers of natural gas are no longer necessary for the functioning of our homes and businesses. San Francisco can lead the state and the country in building a better future.

In addition to recommending the ordinance, I would also like to ask the Commission to recommend the changes to the ordinance as laid out by Earthjustice, the Sierra Club, the San Francisco Climate Emergency Coalition, and other local groups in their letter to the Commission and Board.

It is important to me that we:

1. Eliminate the feasibility exception to the electric-ready requirement and make fully electric-ready construction a baseline requirement for new construction. We know that the future is electric. Allowing any building to be built that will require massive retrofits in the near future is unacceptable. With full electric readiness, we minimize that retrofit cost.
2. Create a Clean Energy Building Hub through the City and County of San Francisco that provides for the outreach, resources, and education needed to eliminate barriers and maximize opportunity for all-electric new construction to benefit both climate and equity.
3. Expand the ordinance's definition of "mixed-fuel buildings" to include laboratory, industrial, and decorative uses of gas. Gas shouldn't be allowed for upscale decorative uses. It's wrong to harm public health for private enjoyment.
4. Provide additional limitations and transparency in the exemption process to ensure any project found exempt for infeasibility is truly in the public interest. I'm concerned about the news of powerful and connected people being able to get favors from DBI. We need sunshine on the exemption process, and exemptions should only be given in the public interest.
5. Amend section 106A.1.17 to require that the Building Official find "sufficient evidence was submitted to substantiate the infeasibility of an All-Electric Building or Project design without regard to financial, floor-area, or amenity-related loss unless deemed to be in the public welfare." The housing crisis is real. And we need to find ways of fixing it without sacrificing our children's future. The space taken up by a transformer should not be an acceptable reason for

an exemption.

6. Eliminate the blanket exemption for commercial kitchens delaying compliance until 2022. Existing restaurants are not helped by giving builders a pass on making future commercial kitchens all-electric.

Thank you for taking up this important issue and considering the health and safety of our residents and climate.

beverlyjmccallister@hotmail.com
2418 Washington Street
San Francisco, California 94115

From: [Ericka Moreno](#)
To: [Major, Erica \(BOS\)](#); [Board of Supervisors, \(BOS\)](#); [Preston, Dean \(BOS\)](#); [Peskin, Aaron \(BOS\)](#); [Safai, Ahsha \(BOS\)](#); [MandelmanStaff, \[BOS\]](#)
Subject: Public Comment Re: BoS File 200701 (Item 1 of 9/21 Land Use)
Date: Saturday, September 19, 2020 1:44:21 PM

This message is from outside the City email system. Do not open links or attachments from untrusted sources.

Land Use Committee, Board of Supervisors, and Sup. Safai,

I'm a resident of San Francisco writing to strongly support prohibiting gas in new construction. The methane leaks, air pollution, and explosion dangers of natural gas are no longer necessary for the functioning of our homes and businesses. San Francisco can lead the state and the country in building a better future.

In addition to recommending the ordinance, I would also like to ask the Commission to recommend the changes to the ordinance as laid out by Earthjustice, the Sierra Club, the San Francisco Climate Emergency Coalition, and other local groups in their letter to the Commission and Board.

It is important to me that we:

1. Eliminate the feasibility exception to the electric-ready requirement and make fully electric-ready construction a baseline requirement for new construction. We know that the future is electric. Allowing any building to be built that will require massive retrofits in the near future is unacceptable. With full electric readiness, we minimize that retrofit cost.
2. Create a Clean Energy Building Hub through the City and County of San Francisco that provides for the outreach, resources, and education needed to eliminate barriers and maximize opportunity for all-electric new construction to benefit both climate and equity.
3. Expand the ordinance's definition of "mixed-fuel buildings" to include laboratory, industrial, and decorative uses of gas. Gas shouldn't be allowed for upscale decorative uses. It's wrong to harm public health for private enjoyment.
4. Provide additional limitations and transparency in the exemption process to ensure any project found exempt for infeasibility is truly in the public interest. I'm concerned about the news of powerful and connected people being able to get favors from DBI. We need sunshine on the exemption process, and exemptions should only be given in the public interest.
5. Amend section 106A.1.17 to require that the Building Official find "sufficient evidence was submitted to substantiate the infeasibility of an All-Electric Building or Project design without regard to financial, floor-area, or amenity-related loss unless deemed to be in the public welfare." The housing crisis is real. And we need to find ways of fixing it without sacrificing our children's future. The space taken up by a transformer should not be an acceptable reason for

an exemption.

6. Eliminate the blanket exemption for commercial kitchens delaying compliance until 2022. Existing restaurants are not helped by giving builders a pass on making future commercial kitchens all-electric.

Thank you for taking up this important issue and considering the health and safety of our residents and climate.

Ericka Moreno
edjnsshoemaker@gmail.com
2 Edinburgh Street
San Francisco, California 94112

From: [Geraldine Masson](#)
To: [Major, Erica \(BOS\)](#)
Cc: [Marstaff \(BOS\)](#); [Board of Supervisors \(BOS\)](#); [Preston, Dean \(BOS\)](#); [Peskin, Aaron \(BOS\)](#); [Safai, Ahsha \(BOS\)](#)
Subject: Public Comment Re: BoS File 200701
Date: Saturday, September 19, 2020 10:10:12 AM

This message is from outside the City email system. Do not open links or attachments from untrusted sources.

Hello,

I'm a resident of San Francisco writing to strongly support prohibiting gas in new construction. The methane leaks, air pollution, and explosion dangers of natural gas are no longer necessary for the functioning of our homes and businesses. San Francisco can lead the state and the country in building a better future.

In addition to recommending the ordinance, I would also like to ask the Commission to recommend the changes to the ordinance as laid out by Earthjustice, the Sierra Club, the San Francisco Climate Emergency Coalition, and other local groups in their letter to the Commission and Board.

It is important to me that we:

1. Eliminate the feasibility exception to the electric-ready requirement and make fully electric-ready construction a baseline requirement for new construction. We know that the future is electric. Allowing any building to be built that will require massive retrofits in the near future is unacceptable. With full electric readiness, we minimize that retrofit cost.
2. Create a Clean Energy Building Hub through the City and County of San Francisco that provides for the outreach, resources, and education needed to eliminate barriers and maximize opportunity for all-electric new construction to benefit both climate and equity.
3. Expand the ordinance's definition of "mixed-fuel buildings" to include laboratory, industrial, and decorative uses of gas. Gas shouldn't be allowed for upscale decorative uses. It's wrong to harm public health for private enjoyment.
4. Provide additional limitations and transparency in the exemption process to ensure any project found exempt for infeasibility is truly in the public interest. I'm concerned about the news of powerful and connected people being able to get favors from DBI. We need sunshine on the exemption process, and exemptions should only be given in the public interest.
5. Amend section 106A.1.17 to require that the Building Official find "sufficient evidence was submitted to substantiate the infeasibility of an All-Electric Building or Project design without regard to financial, floor-area, or amenity-related loss unless deemed to be in

the public welfare." The housing crisis is real. And we need to find ways of fixing it without sacrificing our children's future. The space taken up by a transformer should not be an acceptable reason for an exemption.

6. Eliminate the blanket exemption for commercial kitchens delaying compliance until 2022. Existing restaurants are not helped by giving builders a pass on making future commercial kitchens all-electric.

Thank you for taking up this important issue and considering the health and safety of our residents and climate.

Sincerely,

Géraldyne Masson

From: [Kathryn Vigilante](#)
To: [Major, Erica \(BOS\)](#); [Board of Supervisors, \(BOS\)](#); [Preston, Dean \(BOS\)](#); [Peskin, Aaron \(BOS\)](#); [Safai, Ahsha \(BOS\)](#); [MandelmanStaff, \(BOS\)](#); [Stefani, Catherine \(BOS\)](#)
Subject: Public Comment Re: BoS File 200701 (Item 1 of 9/21 Land Use)
Date: Friday, September 18, 2020 3:23:41 PM

This message is from outside the City email system. Do not open links or attachments from untrusted sources.

Land Use Committee, Board of Supervisors, and Sup. Stefani,

I'm a resident of San Francisco writing to strongly support prohibiting gas in new construction. The methane leaks, air pollution, and explosion dangers of natural gas are no longer necessary for the functioning of our homes and businesses. San Francisco can lead the state and the country in building a better future.

In addition to recommending the ordinance, I would also like to ask the Commission to recommend the changes to the ordinance as laid out by Earthjustice, the Sierra Club, the San Francisco Climate Emergency Coalition, and other local groups in their letter to the Commission and Board.

It is important to me that we:

1. Eliminate the feasibility exception to the electric-ready requirement and make fully electric-ready construction a baseline requirement for new construction. We know that the future is electric. Allowing any building to be built that will require massive retrofits in the near future is unacceptable. With full electric readiness, we minimize that retrofit cost.
2. Create a Clean Energy Building Hub through the City and County of San Francisco that provides for the outreach, resources, and education needed to eliminate barriers and maximize opportunity for all-electric new construction to benefit both climate and equity.
3. Expand the ordinance's definition of "mixed-fuel buildings" to include laboratory, industrial, and decorative uses of gas. Gas shouldn't be allowed for upscale decorative uses. It's wrong to harm public health for private enjoyment.
4. Provide additional limitations and transparency in the exemption process to ensure any project found exempt for infeasibility is truly in the public interest. I'm concerned about the news of powerful and connected people being able to get favors from DBI. We need sunshine on the exemption process, and exemptions should only be given in the public interest.
5. Amend section 106A.1.17 to require that the Building Official find "sufficient evidence was submitted to substantiate the infeasibility of an All-Electric Building or Project design without regard to financial, floor-area, or amenity-related loss unless deemed to be in the public welfare." The housing crisis is real. And we need to find ways of fixing it without sacrificing our children's future. The space taken up by a transformer should not be an acceptable reason for

an exemption.

6. Eliminate the blanket exemption for commercial kitchens delaying compliance until 2022. Existing restaurants are not helped by giving builders a pass on making future commercial kitchens all-electric.

Thank you for taking up this important issue and considering the health and safety of our residents and climate.

Kathryn Vigilante

katievigilante@gmail.com

1267 Chestnut Street, Apt 2

San Francisco, California 94109

From: [Carol Brownson](#)
To: [Major, Erica \(BOS\)](#); [Board of Supervisors, \(BOS\)](#); [Preston, Dean \(BOS\)](#); [Peskin, Aaron \(BOS\)](#); [Safai, Ahsha \(BOS\)](#); [MandelmanStaff, \(BOS\)](#); [Stefani, Catherine \(BOS\)](#)
Subject: Public Comment Re: BoS File 200701 (Item 1 of 9/21 Land Use)
Date: Friday, September 18, 2020 2:59:48 PM

This message is from outside the City email system. Do not open links or attachments from untrusted sources.

Land Use Committee, Board of Supervisors, and Sup. Stefani,

I'm a resident of San Francisco writing to strongly support prohibiting gas in new construction. I'm concerned about a couple of issues in the way the proposal is written.

1. The definition of an "all-electric building or project" should start with a clear statement that no natural gas is allowed to be installed in a building or project unless an exception is granted for the public good. The specific examples should be illustrations, not constitutive of the definition. That approach creates possibilities for loopholes.
2. Exceptions for Mixed-Fuel Buildings. It should be specified that the Building Official's finding that there are grounds for granting an exception to permit the construction of a new Mixed-Fuel building must result from a public process. There is a significant possibility for doubts to arise about the legitimacy of the grant of exception if it is granted without public observation.

Thank you.

Carol Brownson
cdbrownson@gmail.com
2309 California St.
San Francisco, California 94115

From: [Miles Navid-Oster](#)
To: [Major, Erica \(BOS\)](#); [Board of Supervisors, \(BOS\)](#); [Preston, Dean \(BOS\)](#); [Peskin, Aaron \(BOS\)](#); [Safai, Ahsha \(BOS\)](#); [MandelmanStaff, \(BOS\)](#); [Stefani, Catherine \(BOS\)](#)
Subject: Public Comment Re: BoS File 200701 (Item 1 of 9/21 Land Use)
Date: Friday, September 18, 2020 1:18:06 PM

This message is from outside the City email system. Do not open links or attachments from untrusted sources.

Land Use Committee, Board of Supervisors, and Sup. Stefani,

I'm a resident of the city of SF writing to strongly support prohibiting gas in new construction projects. The methane leaks, air pollution, and explosion dangers of natural gas are no longer necessary for the functioning of our homes and businesses. As an architect working in new construction in the city, builders and contractors in the area are competent and knowledgeable in other methods of sustainable energy supply and this would not be a dramatic transition. San Francisco can lead the state and the country in building a better future. In 10-15 years we will see that this should have happened years sooner and it will be a missed opportunity. It is already past the environmental-deadline to maintain our way of life, we need drastic action and immediate policy change to secure a future for our planet and our future generations.

In addition to recommending the ordinance, I would also like to ask the Commission to recommend the changes to the ordinance as laid out by Earthjustice, the Sierra Club, the San Francisco Climate Emergency Coalition, and other local groups in their letter to the Commission and Board:

It is important to me that we:

1. Eliminate the feasibility exception to the electric-ready requirement and make fully electric-ready construction a baseline requirement for new construction. We know that the future is electric. Allowing any building to be built that will require massive retrofits in the near future is unacceptable. With full electric readiness, we minimize that retrofit cost.
2. Create a Clean Energy Building Hub through the City and County of San Francisco that provides for the outreach, resources, and education needed to eliminate barriers and maximize opportunity for all-electric new construction to benefit both climate and equity.
3. Expand the ordinance's definition of "mixed-fuel buildings" to include laboratory, industrial, and decorative uses of gas. Gas shouldn't be allowed for upscale decorative uses. It's wrong to harm public health for private enjoyment.
4. Provide additional limitations and transparency in the exemption process to ensure any project found exempt for infeasibility is truly in the public interest. I'm concerned about the news of powerful and connected people being able to get favors from DBI. We need sunshine on the exemption process, and exemptions should only be given in the public interest.

5. Amend section 106A.1.17 to require that the Building Official find "sufficient evidence was submitted to substantiate the infeasibility of an All-Electric Building or Project design without regard to financial, floor-area, or amenity-related loss unless deemed to be in the public welfare." The housing crisis is real. And we need to find ways of fixing it without sacrificing our children's future. The space taken up by a transformer should not be an acceptable reason for an exemption.

6. Eliminate the blanket exemption for commercial kitchens delaying compliance until 2022. Existing restaurants are not helped by giving builders a pass on making future commercial kitchens all-electric.

Thank you for taking up this important issue and considering the health and safety of residents and climate.

Miles Navid-Oster
mnavidoster@gmail.com
307 Austin St. #A
San Francisco , California 94109

From: [Beverly Tharp](#)
To: [Major, Erica \(BOS\)](#)
Cc: [Ronen, Hillary](#); [Board of Supervisors, \(BOS\)](#); [Preston, Dean \(BOS\)](#); [Peskin, Aaron \(BOS\)](#); [Safai, Ahsha \(BOS\)](#)
Subject: Public Comment Re: BoS File 200701 (Item 1 of 9/21 Land Use)
Date: Friday, September 18, 2020 12:47:11 PM

This message is from outside the City email system. Do not open links or attachments from untrusted sources.

Re: New construction gas ban

Hello,

Since 1980 I've lived in Bernal Heights. In 1989 we had a major earthquake. Even though nothing was damaged it was frightening. We felt it and the after shocks. Our windows bowed and we smelled gas. Everyone's main concern was the gas lines. People turned off their gas even though the meters weren't spinning. People freaked out! Then a few days later they turned the meters on without PG&E's help! A major no-no, but they wanted their gas. We don't need that kind of craziness in an Earthquake One Zone.

On an everyday basis methane leaks from gas are a huge source of pollution. Why would we want to continue this since it's no longer necessary?

Please support the work of SF Climate Emergency Coalition. We are truly in an emergency!

Their recommendations should be followed to strengthen the ordinance so that it isn't bypassed for short term expediency.

As the daughter of a developer I understand the construction industry's imperatives. But they can work for the best outcomes if that's what is asked of them.

Thank you for your consideration.

Sincerely,

Beverly Tharp

From: [Sandra Mack](#)
To: [Major, Erica \(BOS\)](#); [Board of Supervisors, \(BOS\)](#); [Preston, Dean \(BOS\)](#); [Peskin, Aaron \(BOS\)](#); [Safai, Ahsha \(BOS\)](#); [MandelmanStaff, \(BOS\)](#)
Subject: Public Comment Re: BoS File 200701 (Item 1 of 9/21 Land Use)
Date: Friday, September 18, 2020 12:44:52 PM

This message is from outside the City email system. Do not open links or attachments from untrusted sources.

Land Use Committee, Board of Supervisors, and Sup. Preston,

I'm a resident of San Francisco writing to strongly support prohibiting gas in new construction. The methane leaks, air pollution, and explosion dangers of natural gas are no longer necessary for the functioning of our homes and businesses. San Francisco can lead the state and the country in building a better future.

In addition to recommending the ordinance, I would also like to ask the Commission to recommend the changes to the ordinance as laid out by Earthjustice, the Sierra Club, the San Francisco Climate Emergency Coalition, and other local groups in their letter to the Commission and Board.

It is important to me that we:

1. Eliminate the feasibility exception to the electric-ready requirement and make fully electric-ready construction a baseline requirement for new construction. We know that the future is electric. Allowing any building to be built that will require massive retrofits in the near future is unacceptable. With full electric readiness, we minimize that retrofit cost.
2. Create a Clean Energy Building Hub through the City and County of San Francisco that provides for the outreach, resources, and education needed to eliminate barriers and maximize opportunity for all-electric new construction to benefit both climate and equity.
3. Expand the ordinance's definition of "mixed-fuel buildings" to include laboratory, industrial, and decorative uses of gas. Gas shouldn't be allowed for upscale decorative uses. It's wrong to harm public health for private enjoyment.
4. Provide additional limitations and transparency in the exemption process to ensure any project found exempt for infeasibility is truly in the public interest. I'm concerned about the news of powerful and connected people being able to get favors from DBI. We need sunshine on the exemption process, and exemptions should only be given in the public interest.
5. Amend section 106A.1.17 to require that the Building Official find "sufficient evidence was submitted to substantiate the infeasibility of an All-Electric Building or Project design without regard to financial, floor-area, or amenity-related loss unless deemed to be in the public welfare." The housing crisis is real. And we need to find ways of fixing it without sacrificing our children's future. The space taken up by a transformer should not be an acceptable reason for

an exemption.

6. Eliminate the blanket exemption for commercial kitchens delaying compliance until 2022. Existing restaurants are not helped by giving builders a pass on making future commercial kitchens all-electric.

Thank you for taking up this important issue and considering the health and safety of our residents and climate.

Sandra Mack

SAndrasanfran@aol.com

541 Page St

San Francisco, California 94117

From: [Georgie Teuten](#)
To: [Major, Erica \(BOS\)](#); [Board of Supervisors, \(BOS\)](#); [Preston, Dean \(BOS\)](#); [Peskin, Aaron \(BOS\)](#); [Safai, Ahsha \(BOS\)](#); [MandelmanStaff, \[BOS\]](#)
Subject: Public Comment Re: BoS File 200701 (Item 1 of 9/21 Land Use)
Date: Friday, September 18, 2020 11:41:57 AM

This message is from outside the City email system. Do not open links or attachments from untrusted sources.

Land Use Committee, Board of Supervisors, and Sup. Mandelman,

I'm a resident of San Francisco writing to strongly support prohibiting gas in new construction. The methane leaks, air pollution, and explosion dangers of natural gas are no longer necessary for the functioning of our homes and businesses. San Francisco can lead the state and the country in building a better future.

In addition to recommending the ordinance, I would also like to ask the Commission to recommend the changes to the ordinance as laid out by Earthjustice, the Sierra Club, the San Francisco Climate Emergency Coalition, and other local groups in their letter to the Commission and Board.

It is important to me that we:

1. Eliminate the feasibility exception to the electric-ready requirement and make fully electric-ready construction a baseline requirement for new construction. We know that the future is electric. Allowing any building to be built that will require massive retrofits in the near future is unacceptable. With full electric readiness, we minimize that retrofit cost.
2. Create a Clean Energy Building Hub through the City and County of San Francisco that provides for the outreach, resources, and education needed to eliminate barriers and maximize opportunity for all-electric new construction to benefit both climate and equity.
3. Expand the ordinance's definition of "mixed-fuel buildings" to include laboratory, industrial, and decorative uses of gas. Gas shouldn't be allowed for upscale decorative uses. It's wrong to harm public health for private enjoyment.
4. Provide additional limitations and transparency in the exemption process to ensure any project found exempt for infeasibility is truly in the public interest. I'm concerned about the news of powerful and connected people being able to get favors from DBI. We need sunshine on the exemption process, and exemptions should only be given in the public interest.
5. Amend section 106A.1.17 to require that the Building Official find "sufficient evidence was submitted to substantiate the infeasibility of an All-Electric Building or Project design without regard to financial, floor-area, or amenity-related loss unless deemed to be in the public welfare." The housing crisis is real. And we need to find ways of fixing it without sacrificing our children's future. The space taken up by a transformer should not be an acceptable reason for

an exemption.

6. Eliminate the blanket exemption for commercial kitchens delaying compliance until 2022. Existing restaurants are not helped by giving builders a pass on making future commercial kitchens all-electric.

Thank you for taking up this important issue and considering the health and safety of our residents and climate.

Georgie Teuten
ghteuten@gmail.com
400 Duboce Ave
San Francisco, California 94117

From: [Delaney Chambers](#)
To: [Major, Erica \(BOS\)](#)
Cc: [Board of Supervisors, \(BOS\)](#); [Preston, Dean \(BOS\)](#); [Peskin, Aaron \(BOS\)](#); [Safai, Ahsha \(BOS\)](#); [Stefani, Catherine \(BOS\)](#)
Subject: Concern from SF Neighbor Regarding BoS File 200701
Date: Friday, September 18, 2020 11:39:47 AM

This message is from outside the City email system. Do not open links or attachments from untrusted sources.

Hi,

My name's Delaney, I moved to San Francisco 6 years ago for a lot of reasons but the primary one being that I love the culture of diversity, care, and appreciation for the planet. The secondary reason is because I got a job out here, in construction. So I feel equipped to state that I strongly support prohibiting gas in new construction.

San Francisco can lead the state and the country in building a better future.

In addition to recommending the ordinance, I would also like to ask the Commission to recommend the changes to the ordinance as laid out by Earthjustice, the Sierra Club, the San Francisco Climate Emergency Coalition, and other local groups in their letter to the Commission and Board.

Thank you for taking up this important issue and considering the health and safety of our residents and climate. I look forward to hearing the results of Monday's meeting

Best,

Delaney Chambers (she/her)
dischambers@gmail.com
301-221-7998 | [LinkedIn](#)

From: [Amelia Jones](#)
To: [Major, Erica \(BOS\)](#)
Cc: [Stefani, Catherine \(BOS\)](#); [Board of Supervisors, \(BOS\)](#); [Preston, Dean \(BOS\)](#); [Peskin, Aaron \(BOS\)](#); [Safai, Ahsha \(BOS\)](#)
Subject: Public Comment Re: BoS File 200701
Date: Friday, September 18, 2020 10:52:52 AM

This message is from outside the City email system. Do not open links or attachments from untrusted sources.

To the San Francisco Board of Directors,
My name is Amelia and I'm a resident of San Francisco, living in Supervisor District 2, writing to strongly support prohibiting natural gas in new construction. After living through the horribly oppressive air pollution generated by nearby, climate-change-exacerbated wildfires these last few weeks, it cannot be more plainly crucial than it is now that San Francisco, often looked to globally as a city on the forefront of pro-climate policy, take strong action against the continued burning of fossil fuels.

Once touted as a "bridge" to renewable energy, the myth that natural gas can power us through to the renewable revolution has been widely debunked. Not only does the burning of natural gas contribute methane emissions to our atmosphere, the methane leaks during extraction, air pollution, and explosion dangers of natural gas are no longer necessary for the functioning of our homes and businesses. San Francisco has a prime opportunity to lead the state, the country, and the world in building a better future.

In addition to recommending the ordinance, I would also like to ask the Commission to recommend the changes to the ordinance as laid out by Earthjustice, the Sierra Club, the San Francisco Climate Emergency Coalition, and other local groups in their letter to the Commission and Board.

It is important to me that we:

- 1. Eliminate the feasibility exception** to the electric-ready requirement and **make fully electric-ready construction a baseline requirement for new construction.** We know that the future is electric. Allowing any building to be built that will require massive retrofits in the near future is unacceptable. With full electric readiness, we minimize that retrofit cost.
- 2. Create a Clean Energy Building Hub** through the City and County of San Francisco that provides for the **outreach, resources, and education needed to eliminate barriers and maximize opportunity** for all-electric new construction to benefit both climate and equity.
- 3. Expand the ordinance's definition of "mixed-fuel buildings"** to include laboratory, industrial, and decorative uses of gas. Gas shouldn't be allowed for upscale decorative uses. **It's wrong to harm public health for private enjoyment.**
- 4. Provide additional limitations and transparency in the exemption process** to ensure any project found exempt for infeasibility is truly in the public interest. I'm concerned about the news of powerful and connected people being able to get favors from DBI. We need to shine

a light on the exemption process, and **exemptions should only be given in the public interest.**

5. Amend section 106A.1.17 to require that the Building Official find “sufficient evidence was submitted to substantiate the infeasibility of an All-Electric Building or Project design without regard to financial, floor-area, or amenity-related loss unless deemed to be in the public welfare.” The housing crisis is real. And we need to find ways of fixing it without sacrificing our children's future. **The space taken up by a transformer should not be an acceptable reason for an exemption.**

6. Eliminate the blanket exemption for commercial kitchens delaying compliance until 2022. Existing restaurants are not helped by giving builders a pass on making future commercial kitchens all-electric.

Thank you for taking up this important issue and considering the health and safety of our residents and climate. I look forward to following the Land Use Committee of the Board of Supervisors discussions around this new legislation beginning on Monday.

Sincerely,

Amelia T. Jones
amelia.jones735@gmail.com
1865 Chestnut St
San Francisco, CA 94123
m. (443) 844-4424

From: [Rebecca Barker](#)
To: [Major, Erica \(BOS\)](#); [Peskin, Aaron \(BOS\)](#); [Angulo, Sunny \(BOS\)](#); [Hepner, Lee \(BOS\)](#); [Safai, Ahsha \(BOS\)](#); [Sandoval, Suhagey \(BOS\)](#); [Preston, Dean \(BOS\)](#); [Snyder, Jen \(BOS\)](#); [Smeallie, Kyle \(BOS\)](#); [Mandelman, Rafael \(BOS\)](#); [Bintliff, Jacob \(BOS\)](#); [MandelmanStaff, \[BOS\]](#); [Board of Supervisors, \(BOS\)](#)
Cc: dktahara@gmail.com; c@n-a-s-o.com; mvespa@earthjustice.org
Subject: Environmental Organizations' Public Comment Supporting Ordinance 200701
Date: Friday, September 18, 2020 9:34:16 AM
Attachments: [ATT00001.png](#)
[Environmental Orgs Support for SF All Electric New Construction Ordinance.pdf](#)

This message is from outside the City email system. Do not open links or attachments from untrusted sources.

Hello,

Attached please find a public comment letter from a group of environmental organizations supporting Ordinance 200701, agenda item #1 on the Land Use and Transportation Committee's 9/21 meeting agenda. Please add this written comment to the Board of Supervisors record for the ordinance generally and for consideration by the Committee ahead of their upcoming meeting.

Thank you,
Rebecca Barker

Rebecca Barker
She/her/hers
Associate Attorney
Clean Energy Program
50 California Street, Suite 500
San Francisco, CA 94111
Phone: 415.217.2056
rbarker@earthjustice.org



The information contained in this email message may be privileged, confidential and protected from disclosure. If you are not the intended recipient, any dissemination, distribution or copying is strictly prohibited. If you think that you have received this email message in error, please notify the sender by reply email and delete the message and any attachments.



September 18, 2020

VIA EMAIL

Erica Major
 Assistant Clerk
 Land Use and Transportation Committee
 San Francisco Board of Supervisors
 1455 Market Street, Suite 1200
 San Francisco, CA 94103
 Erica.Major@sfgov.org

To the Board of Supervisors Land Use and Transportation Committee:

We are writing to support Supervisor Mandelman’s proposed ordinance requiring all-electric buildings for new construction. Local jurisdictions across the state have amended their

reach codes or introduced ordinances to decarbonize their building sectors, and San Francisco has the opportunity to emerge as a leader in this movement by taking a strong stance against fossil fuels and requiring all-electric construction in all new building projects.

We commend Supervisor Mandelman and the numerous stakeholder groups he engaged for taking the initiative to develop and introduce this important legislation. In addition, to more fully realize the health, climate and economic benefits of electrification and ensure that any exemptions to this important requirement are under legitimately exceptional circumstances, we ask that the following changes be made to strengthen the ordinance and implementing regulations:

- 1) eliminate the feasibility exception to the electric-ready requirement;
- 2) create a Clean Energy Buildings Hub that evaluates equity and economic considerations and informs the creation of additional education and technical support resources for affected groups (e.g., small businesses, restaurants, affordable housing, contractors, workforce standards), maximizing opportunities and eliminating barriers to utilization of all-electric new construction to address climate and equity;
- 3) expand and clarify the definition of “Mixed-Fuel Buildings” in the ordinance to include laboratory and industrial buildings, as well as decorative uses of gas;
- 4) provide additional limitations and transparency in the exemption process to ensure any project found exempt for infeasibility is truly in the public interest; and
- 5) eliminate the blanket exemption for commercial kitchens delaying compliance until 2022.

The Ordinance Will Protect the Health and Safety of San Francisco Residents

Gas appliances in buildings make up a quarter of California’s nitrogen oxide (NO_x) emissions from natural gas. NO_x is a precursor to ozone and particulate matter, which are key pollutants to curb in order to comply with state and federal ambient air quality standards. Electrifying buildings will help reduce NO_x and ground level ozone, improving *outdoor* air quality and benefiting public health. A recent study from the UCLA Fielding School of Public Health found that immediate replacement of all residential gas appliances with clean electric alternatives would result in 354 fewer deaths, 596 fewer cases of acute bronchitis, and 304 fewer cases of chronic bronchitis *annually* in California due to improvements in outdoor air quality alone—the monetized equivalent of \$3.5 billion in health benefits per year.¹

Electrification of fossil fuel appliances will also immediately improve *indoor* air quality and health. On average, Californians spend 68 percent of their time indoors, making indoor air quality a key determinant of human health.² The combustion of gas in household appliances produces harmful indoor air pollution, specifically nitrogen dioxide, carbon monoxide, nitric oxide, formaldehyde, acetaldehyde, and ultrafine particles, often in excess of the levels set out by

¹ Zhu, *et al.*, *Effects of Residential Gas Appliances on Indoor and Outdoor Air Quality and Public Health in California*, UCLA Fielding School of Public Health (April 2020).

² Klepeis *et al.*, *The National Human Activity Pattern Survey (NHAPS): A Resource for Assessing Exposure to Environmental Pollutants*, J. EXPO. ANAL. ENVIRON. EPIDEMIOL., Vol. 11(3), 231-52 (2001).

the California Ambient Air Quality Standards and the National Ambient Air Quality Standards.³ ⁴ The California Air Resources Board warns that “cooking emissions, especially from gas stoves, have been associated with increased respiratory disease.”⁵ Young children and people with asthma are especially vulnerable to indoor air pollution, and the negative health impacts associated with gas appliance use disproportionately affect low-income residents, who are often renters rather than homeowners and tend to live in smaller spaces, resulting in higher concentration of indoor air pollutants.⁶

Chronic exposure to air pollution has also been linked to poor health outcomes during the COVID-19 crisis.⁷ A study from the Harvard T.H. Chan School of Public Health analyzed data from more than 3,000 counties across the United States to assess the link between long-term average exposure to air pollutants and COVID-19 death rates. The study found that “an increase of only $1 \mu\text{g}/\text{m}^3$ in $\text{PM}_{2.5}$ is associated with an 8% increase in the COVID-19 death rate,” meaning even small increases in long-term exposure to particulate matter can translate into significant increases in county-wide death rates from the virus.⁸ This data is a stark reminder of the devastating effects that air pollution has on affected communities, and underscores the need for major urban centers like San Francisco both to uphold existing safeguards against air pollution and to take a strong stance moving forward to protect the health and safety of their residents.

The Ordinance is a Critical Step in Fighting the Climate Emergency

Stationary energy use represents a major source of greenhouse gas (“GHG”) emissions, much of which comes from gas end uses, such as space and water heating. In *Residential Building Electrification in California*, E3 determined that “electrification is found to reduce total greenhouse gas emissions in single family homes by approximately 30 to 60 percent in 2020, relative to a natural gas-fueled home.”⁹ Moreover, “[a]s the carbon intensity of the grid decreases over time, these savings are estimated to increase to approximately 80 to 90 percent by 2050, including the impacts of upstream methane leakage and refrigerant gas leakage from air conditioners and heat pumps.”¹⁰

³ See, e.g., Logue *et al.*, *Pollutant Exposures from Natural Gas Cooking Burners: A Simulation-Based Assessment for Southern California*, ENVIRON. HEALTH PERSP., Vol. 122(1), 43-50 (2014); Victoria Klug & Brett Singer, *Cooking Appliance Use in California Homes—Data Collected from a Web-based Survey*, LAWRENCE BERKELEY NATIONAL LABORATORY (Aug. 2011); John Manuel, *A Healthy Home Environment?* ENVIRON. HEALTH PERSP., Vol. 107(7), 352-57 (1999); Mullen *et al.*, *Impact of Natural Gas Appliances on Pollutant Levels in California Homes*, LAWRENCE BERKELEY NATIONAL LABORATORY (2012).

⁴ Zhu, *et al.*, at 12-13.

⁵ California Air Resources Board, *Combustion Pollutants* (last reviewed Jan. 19, 2017), <https://www.arb.ca.gov/research/indoor/combustion.htm>.

⁶ Zhu, *et al.*, at 10.

⁷ Wu, *et al.*, *Exposure to Air Pollution and COVID-19 Mortality in the United States: A Nationwide Cross-Sectional Study*, Harvard T.H. Chan School of Public Health (updated April 24, 2020).

⁸ *Id.*

⁹ E3, *Residential Building Electrification in California* at iv (Apr. 2019), https://www.ethree.com/wp-content/uploads/2019/04/E3_Residential_Building_Electrification_in_California_April_2019.pdf.

¹⁰ *Id.*

Building electrification brings significant GHG reductions, not only due to the energy mix on the grid, which was, in PG&E’s and CleanPowerSF’s service territories, respectively, 85 and 89 percent carbon-free in 2018,¹¹ but also because heat pump technology is extraordinarily efficient. Rather than needing to generate heat through the combustion of fossil gas, heat pumps extract existing heat from the surrounding environment. Because electricity is used to move heat around rather than to create it, heat pump water heater (“HPWH”) efficiency is far greater than 100 percent (energy services delivered are much greater than energy input). Accordingly, HPWHs use much less energy to heat water,¹² and HPWHs generate significantly less GHGs than even the most efficient gas water heating.¹³

Industry leaders have shown that all-electric construction is feasible for all building types, from single-family residences to large, commercial buildings.¹⁴ For example, Stanford University has converted its campus from a system reliant on a fossil-fuel-based combined heat and power plant to a mix of grid-sourced electricity and an electric heat recovery system that uses heat pump technology to store thermal energy and to meet the campus’s space and water heating needs, reducing the GHG impact of its roughly 12 million square feet of building stock by 68% below peak levels.¹⁵ Similar all-electric retrofits and new construction have been adopted for large-scale corporate campuses like Tesla and Google, among others.¹⁶ These resounding success stories support a comprehensive gas ban that covers all building types, avoiding a slow, piecemeal transition.

The Ordinance Will Develop the Local Workforce

Building electrification will also spur development of the local workforce for jobs that will be critical in California’s broader energy transition. For example, in Sacramento Municipal Utility District territory, where all-electric buildings are quickly becoming the default for new developments, demand for specialized plumbers and HVAC technicians is expected to grow enormously. The region expects to install more than 300,000 heat pump space heaters in the next 15 to 20 years.¹⁷ Additionally, a 2019 study from the UCLA Luskin Center for Innovation

¹¹ PG&E, Corporate Responsibility and Sustainability Report: 2019, at 38. Available at: http://www.pgecorp.com/corp_responsibility/reports/2019/assets/PGE_CRSR_2019.pdf; CleanPowerSF Power Draft Power Content Label: 2018. Available at: <https://www.cleanpowersf.org/s/2018-CleanPowerSF-PCL.pdf>.

¹² See Pub. Util. Code § 397.6(k)(3) (a measure of SGIP success and impact is the “amount of energy reductions measured in energy value.”).

¹³ See Pub. Util. Code § 379.6(k)(1) (a measure of SGIP success and impact is the “amount of reductions of emissions of greenhouse gases.”).

¹⁴ Redwood Energy, *Zero Carbon Commercial Construction: An Electrification Guide for Large Commercial Buildings and Campuses* (2019). Available at: <https://www.redwoodenergy.tech/wp-content/uploads/2019/09/Pocket-Guide-to-Zero-Carbon-Commercial-Buildings-2nd-Edition.pdf>

¹⁵ Stanford University, *Stanford Energy Systems Innovations Fact Sheet*. Available at: https://sustainable.stanford.edu/sites/default/files/SESI_Condensed_factsheet2017.pdf. See also Stanford University, *Energy and Climate Plan*. Available at: <https://sustainable.stanford.edu/sites/default/files/E%26C%20Plan%202016.6.7.pdf>.

¹⁶ Redwood Energy, at 3-4.

¹⁷ Justin Gerdes, *Experts Discuss the Biggest Barriers Holding Back Building Electrification*, Greentech Media (Sept. 19, 2018), <https://www.greentechmedia.com/articles/read/here-are-some-of-the-biggest-barriers-holding-back-building-electrification#gs.fBEBKJy2>.

found that electrification of 100 percent of California’s existing and new buildings by 2045 would generate new jobs for more than 100,000 full time construction workers and up to 4,900 full time manufacturing workers.¹⁸ While gas distribution jobs would decrease, they are projected to be replaced by almost double the amount of full time jobs in electricity generation and distribution.¹⁹ Further, because California imports 90 percent of its natural gas from out of state, it can reduce gas imports first while preserving in-state gas industry jobs, which will ease the strain of industry transition on gas industry workers.²⁰ The UCLA study stresses that planning—including implementing and enforcing clear building codes and standards—will be crucial in protecting workers through an industry transition that is already underway.²¹ Recognizing the widespread energy transition already underway statewide, San Francisco has an opportunity to lead California’s major urban centers by developing a robust, comprehensive local legal framework to support electrification and generate thousands of good, green jobs for its residents.

In light of this, we commend the introduction of an all-electric construction ordinance, not only as a response to the climate emergency, but also in support of new jobs and the health and safety of the people of San Francisco. To fully realize these benefits, avoid unnecessary stranded asset consequences of continued buildout of gas infrastructure, and ensure the City’s actions are commensurate with the urgency of the climate crisis, it is critical that any exemptions to all-electric new construction be as narrowly tailored as possible and avoid the potential for loopholes. We therefore urge the following modification to the ordinance and implemented code to ensure exemptions are in legitimately exceptional circumstances.

1. Eliminate the feasibility exception to the electric-ready requirement and make fully electric-ready construction a baseline requirement for new construction. To avoid creating obstacles to future electrification, any new construction project that is found exempt from the all-electric requirement due to infeasibility must be required, as a baseline, to adhere to an electric-ready design, *i.e.*, to install sufficient electric service, conduit, and wiring to facilitate full building electrification in the future.

An electric-ready requirement as an interim step will ensure that developers do not push gas-reliant projects through the exemption process for physical infeasibility, which will ultimately be costly and burdensome to retrofit.

2. Establish a Clean Energy Buildings Hub to support, connect, and train workers, contractors, building owners, facilities managers, technology vendors, and other interested parties, run by the City and County of San Francisco. The hub would be a one-stop shop for electrification and fuel-switching, energy efficiency, water efficiency, solar technologies, and electric vehicle resources. Resources would be culturally

¹⁸ UCLA Luskin Center for Innovation, *California Building Decarbonization: Workforce Needs and Recommendations*, at ES-iv (Nov. 2019).

¹⁹ *Id.*

²⁰ *Id.* at 24-25.

²¹ *Id.* at 27-28.

competent, multi-lingual, and accessible to all San Francisco residents. This recommendation is a result of the work of the San Francisco Department of Environment's Energy Efficiency Coordinating Committee and the Residential Building Electrification Task Force.

Potential elements could include, but are not limited to:

- A referral service for single trade contractors to partner on jobs and provide cross-trade training;
- Regional collaboration on building standards, such as reach codes, that vary by jurisdiction;
- Information about local and state distributed generation and energy efficiency programs providing financial and other support to low-income and marginalized communities;
- Collaboration between manufacturers and general contractors to identify opportunities to reduce the rising costs of construction, and develop group purchasing and contracting programs; and
- Opportunities for group purchasing of electrification technologies between residents/neighbors, with partnerships between the City and County of San Francisco and high quality manufacturers providing subsidies and bulk purchasing options.

3. Expand the ordinance's definition of "mixed-fuel buildings" to include laboratory, industrial, and decorative uses of gas. As written, the definition of "mixed-fuel buildings" limits the application of the ordinance just to buildings using gas for "space heating or cooling, water heating (including pools and spas), cooking appliances or clothes drying appliances, [or] onsite generation of electricity," or buildings that contain "fixtures, piping systems, or infrastructure for natural gas or propane equipment *for such uses.*" Amending this definition to include laboratory, industrial, and decorative uses of gas (e.g., outdoor fireplaces or lamps) will ensure comprehensive application of the ordinance, as intended, subject to the infeasibility exemption on a case-by-case basis.

4. Provide additional limitations and transparency in the exemption process to ensure any project found exempt for infeasibility is truly in the public interest. The current proposed process for reviewing exemptions for physical infeasibility would take place behind closed doors with no opportunity for public comment or appeal. Without additional safeguards in place, developers may take advantage of the process to advance projects that do not serve the health and safety interests of the public, including the future workers and/or residents of the proposed development. A more transparent review process will enable public engagement and greater public confidence that exemptions are limited and made only in legitimately exceptional circumstances.

Further, amending section 106A.1.17 to require that that Building Official find "sufficient evidence was submitted to substantiate the infeasibility of an All-Electric Building or Project design *without regard to financial, floor-area, or amenity-related loss unless deemed to be in the public welfare,*" would prevent developers from designing projects that claim physical infeasibility to avoid using space inside the building to house the

necessary equipment. This amendment ensures the focus remains on public health and welfare, rather than profit maximization for developers and landlords, while giving the Building Official discretion to determine case-specific exemptions that may serve the public interest.

5. Eliminate the blanket exemption for commercial kitchens delaying compliance until 2022. Restaurant workers who spend hours working in commercial kitchens daily are at particularly high risk for the negative health effects of gas stoves. Additionally, because this ordinance affects only new construction, this exemption does not stand to benefit existing local small businesses, but rather, caters to developers seeking to build brand-new commercial spaces. This exemption does not protect the interests of the local restaurant owners and will delay the transition to a fully decarbonized building stock with no balancing benefit in the public interest. An all-electric requirement with no categorical exemptions or delays is commensurate with the urgency of the climate crisis.

Thank you for your leadership moving San Francisco forward in realizing the many benefits of healthy, fossil fuel free homes. Please do not hesitate to reach out if you have any questions, and please include us on your contact list for any further developments on the proposed ordinance.

Sincerely,

Earthjustice	San Francisco Climate Emergency Coalition
Alliance of Nurses for Healthy Environments	Physicians for Social Responsibility SF Bay Chapter
Climate Health Now	350 San Francisco
350 Bay Area	Integral Group
Sunflower Alliance	Food & Water Action
Mothers Out Front California	Redwood Energy
Ban Gas San Francisco	Sierra Club
Mothers Out Front San Francisco	Alter Consulting Engineers
Sunrise Movement - Bay Area	PIVOT: The Progressive Vietnamese American Organization
PODER: People Organizing to Demand Environmental and Economic Rights	North American Passive House Network

Passive House California

San Francisco Tomorrow

Citizens' Climate Lobby – San Francisco

Sierra Club – SF Bay Chapter

Emerald Cities San Francisco

Bay Area Living Future Collaborative

cc: Aaron.Peskin@sfgov.org
Sunny.Angulo@sfgov.org
Lee.Hepner@sfgov.org
Ahsha.Safai@sfgov.org
Suhagey.Sandoval@sfgov.org
Dean.Preston@sfgov.org
Jen.Snyder@sfgov.org
Kyle.Smeallie@sfgov.org
Rafael.Mandelman@sfgov.org
Jacob.Bintliff@sfgov.org
mandelmanstaff@sfgov.org
Board.of.Supervisors@sfgov.org

From: [Bill WEIHL](#)
To: [Major, Erica \(BOS\)](#); [Board of Supervisors, \(BOS\)](#); [Preston, Dean \(BOS\)](#); [Peskin, Aaron \(BOS\)](#); [Safai, Ahsha \(BOS\)](#); [MandelmanStaff, \[BOS\]](#)
Subject: Public Comment Re: BoS File 200701 (Item 1 of 9/21 Land Use)
Date: Friday, September 18, 2020 9:33:51 AM

This message is from outside the City email system. Do not open links or attachments from untrusted sources.

Land Use Committee, Board of Supervisors, and Sup. Mandelman,

I'm a resident of San Francisco in District 8 writing to strongly support prohibiting gas in new construction. The methane leaks, air pollution, and explosion dangers of natural gas are no longer necessary for the functioning of our homes and businesses. San Francisco can lead the state and the country in building a better future.

I have spent the past 15 years of my career working on climate and clean energy in the tech industry - leading sustainability work first for Google and then for Facebook. I am now running a non-profit, ClimateVoice, focused on getting companies to do more on climate. The climate crisis is urgent, and no longer remote in time or space - it is affecting us here and now. I am worried about our immediate future, and also the future we are leaving for our children and grandchildren. We must stop expanding our use of gas and other fossil fuels now - and then work over the next decade or two to phase them out completely.

In addition to recommending the ordinance, I would also like to ask the Commission to recommend the changes to the ordinance as laid out by Earthjustice, the Sierra Club, the San Francisco Climate Emergency Coalition, and other local groups in their letter to the Commission and Board.

It is important to me that we:

1. Eliminate the feasibility exception to the electric-ready requirement and make fully electric-ready construction a baseline requirement for new construction. We know that the future is electric. Allowing any building to be built that will require massive retrofits in the near future is unacceptable. With full electric readiness, we minimize that retrofit cost.
2. Create a Clean Energy Building Hub through the City and County of San Francisco that provides for the outreach, resources, and education needed to eliminate barriers and maximize opportunity for all-electric new construction to benefit both climate and equity.
3. Expand the ordinance's definition of "mixed-fuel buildings" to include laboratory, industrial, and decorative uses of gas. Gas shouldn't be allowed for upscale decorative uses. It's wrong to harm public health for private enjoyment.
4. Provide additional limitations and transparency in the exemption process to ensure any project found exempt for infeasibility is truly in the public interest. I'm concerned about the

news of powerful and connected people being able to get favors from DBI. We need sunshine on the exemption process, and exemptions should only be given in the public interest.

5. Amend section 106A.1.17 to require that the Building Official find "sufficient evidence was submitted to substantiate the infeasibility of an All-Electric Building or Project design without regard to financial, floor-area, or amenity-related loss unless deemed to be in the public welfare." The housing crisis is real. And we need to find ways of fixing it without sacrificing our children's future. The space taken up by a transformer should not be an acceptable reason for an exemption.

6. Eliminate the blanket exemption for commercial kitchens delaying compliance until 2022. Existing restaurants are not helped by giving builders a pass on making future commercial kitchens all-electric.

Thank you for taking up this important issue and considering the health and safety of our residents and climate.

Bill WEIHL
bill@weihl.com
280 Clipper Street
San Francisco, California 94114

From: [Bharath Kumandan](#)
To: [Major, Erica \(BOS\)](#)
Cc: [Haney, Matt \(BOS\)](#); [Board of Supervisors, \(BOS\)](#); [Preston, Dean \(BOS\)](#); [Peskin, Aaron \(BOS\)](#); [Safai, Ahsha \(BOS\)](#)
Subject: Public Comment Re: BoS File 200701
Date: Thursday, September 17, 2020 11:00:30 PM

This message is from outside the City email system. Do not open links or attachments from untrusted sources.

I'm a resident of San Francisco writing to strongly support prohibiting gas in new construction. The methane leaks, air pollution, and explosion dangers of natural gas are no longer necessary for the functioning of our homes and businesses. San Francisco can lead the state and the country in building a better future.

In addition to recommending the ordinance, I would also like to ask the Commission to recommend the changes to the ordinance as laid out by Earthjustice, the Sierra Club, the San Francisco Climate Emergency Coalition, and other local groups in their letter to the Commission and Board.

It is important to me that we:

1. Eliminate the feasibility exception to the electric-ready requirement and make fully electric-ready construction a baseline requirement for new construction. We know that the future is electric. Allowing any building to be built that will require massive retrofits in the near future is unacceptable. With full electric readiness, we minimize that retrofit cost.
2. Create a Clean Energy Building Hub through the City and County of San Francisco that provides for the outreach, resources, and education needed to eliminate barriers and maximize opportunity for all-electric new construction to benefit both climate and equity.
3. Expand the ordinance's definition of "mixed-fuel buildings" to include laboratory, industrial, and decorative uses of gas. Gas shouldn't be allowed for upscale decorative uses. It's wrong to harm public health for private enjoyment.
4. Provide additional limitations and transparency in the exemption process to ensure any project found exempt for infeasibility is truly in the public interest. I'm concerned about the news of powerful and connected people being able to get favors from DBI. We need sunshine on the exemption process, and exemptions should only be given in the public interest.
5. Amend section 106A.1.17 to require that the Building Official find "sufficient evidence was submitted to substantiate the infeasibility of an All-Electric Building or Project design without regard to financial, floor-area, or amenity-related loss unless deemed to be in the public welfare." The housing crisis is real. And we need to find ways of fixing it without sacrificing our children's future. The space taken up by a

transformer should not be an acceptable reason for an exemption.

6. Eliminate the blanket exemption for commercial kitchens delaying compliance until 2022. Existing restaurants are not helped by giving builders a pass on making future commercial kitchens all-electric.

Thank you for taking up this important issue and considering the health and safety of our residents and climate.

Sincerely,

Bharath Kumandan

481 Clementina St., Unit D, San Francisco, CA 94103

From: [Bonnie Hu](#)
To: [Major, Erica \(BOS\)](#); [Board of Supervisors, \(BOS\)](#); [Preston, Dean \(BOS\)](#); [Peskin, Aaron \(BOS\)](#); [Safai, Ahsha \(BOS\)](#); [MandelmanStaff, \[BOS\]](#)
Subject: Public Comment Re: BoS File 200701 (Item 1 of 9/21 Land Use)
Date: Thursday, September 17, 2020 9:27:08 PM

This message is from outside the City email system. Do not open links or attachments from untrusted sources.

Land Use Committee, Board of Supervisors, and Sup. Peskin,

I'm a resident of San Francisco writing to strongly support prohibiting gas in new construction. The methane leaks, air pollution, and explosion dangers of natural gas are no longer necessary for the functioning of our homes and businesses. San Francisco can lead the state and the country in building a better future.

In addition to recommending the ordinance, I would also like to ask the Commission to recommend the changes to the ordinance as laid out by Earthjustice, the Sierra Club, the San Francisco Climate Emergency Coalition, and other local groups in their letter to the Commission and Board.

It is important to me that we:

1. Eliminate the feasibility exception to the electric-ready requirement and make fully electric-ready construction a baseline requirement for new construction. We know that the future is electric. Allowing any building to be built that will require massive retrofits in the near future is unacceptable. With full electric readiness, we minimize that retrofit cost.
2. Create a Clean Energy Building Hub through the City and County of San Francisco that provides for the outreach, resources, and education needed to eliminate barriers and maximize opportunity for all-electric new construction to benefit both climate and equity.
3. Expand the ordinance's definition of "mixed-fuel buildings" to include laboratory, industrial, and decorative uses of gas. Gas shouldn't be allowed for upscale decorative uses. It's wrong to harm public health for private enjoyment.
4. Provide additional limitations and transparency in the exemption process to ensure any project found exempt for infeasibility is truly in the public interest. I'm concerned about the news of powerful and connected people being able to get favors from DBI. We need sunshine on the exemption process, and exemptions should only be given in the public interest.
5. Amend section 106A.1.17 to require that the Building Official find "sufficient evidence was submitted to substantiate the infeasibility of an All-Electric Building or Project design without regard to financial, floor-area, or amenity-related loss unless deemed to be in the public welfare." The housing crisis is real. And we need to find ways of fixing it without sacrificing our children's future. The space taken up by a transformer should not be an acceptable reason for

an exemption.

6. Eliminate the blanket exemption for commercial kitchens delaying compliance until 2022. Existing restaurants are not helped by giving builders a pass on making future commercial kitchens all-electric.

Thank you for taking up this important issue and considering the health and safety of our residents and climate.

Bonnie Hu

bonniehu@gmail.com

1001 Pine Street Unit 608

San Francisco, California 94109

From: [Stephen Reichling](#)
To: [Major, Erica \(BOS\)](#); [Board of Supervisors, \(BOS\)](#); [Preston, Dean \(BOS\)](#); [Peskin, Aaron \(BOS\)](#); [Safai, Ahsha \(BOS\)](#); [MandelmanStaff, \[BOS\]](#)
Subject: Public Comment Re: BoS File 200701 (Item 1 of 9/21 Land Use)
Date: Thursday, September 17, 2020 5:40:27 PM

This message is from outside the City email system. Do not open links or attachments from untrusted sources.

Land Use Committee, Board of Supervisors, and Sup. Preston,

I'm a resident of San Francisco and a constituent of Supervisor Dean Preston. I'm writing to voice my strong support of prohibiting gas in new construction. It's essential step to cutting one of San Francisco's major sources of the type of greenhouse gas emissions that drive the wildfires. Not only do these fires make our air unbreathable, they have forced thousands of Californians to evacuate homes, worsening the housing crisis and furthering the spread of the coronavirus. We are long past being able to kick this problem further down the road.

Additionally, I would also like to ask the Commission to recommend the changes to the ordinance as laid out by Earthjustice, the Sierra Club, the San Francisco Climate Emergency Coalition, and other local groups in their letter to the Commission and Board.

It is important to me that we:

1. Eliminate the feasibility exception to the electric-ready requirement and make fully electric-ready construction a baseline requirement for new construction. We know that the future is electric. Allowing any building to be built that will require massive retrofits in the near future is unacceptable. With full electric readiness, we minimize that retrofit cost.
2. Create a Clean Energy Building Hub through the City and County of San Francisco that provides for the outreach, resources, and education needed to eliminate barriers and maximize opportunity for all-electric new construction to benefit both climate and equity.
3. Expand the ordinance's definition of "mixed-fuel buildings" to include laboratory, industrial, and decorative uses of gas. Gas shouldn't be allowed for upscale decorative uses. It's wrong to harm public health for private enjoyment.
4. Provide additional limitations and transparency in the exemption process to ensure any project found exempt for infeasibility is truly in the public interest. I'm concerned about the news of powerful and connected people being able to get favors from DBI. We need sunshine on the exemption process, and exemptions should only be given in the public interest.
5. Amend section 106A.1.17 to require that the Building Official find "sufficient evidence was submitted to substantiate the infeasibility of an All-Electric Building or Project design without regard to financial, floor-area, or amenity-related loss unless deemed to be in the public welfare." The housing crisis is real. And we need to find ways of fixing it without sacrificing our

children's future. The space taken up by a transformer should not be an acceptable reason for an exemption.

6. Eliminate the blanket exemption for commercial kitchens delaying compliance until 2022. Existing restaurants are not helped by giving builders a pass on making future commercial kitchens all-electric.

Thank you for taking up this important issue and considering the health and safety of our residents and climate.

Stephen Reichling
smreichling@gmail.com
78 Parnassus Ave
San Francisco, California 94117

From: [Lucy Duan](#)
To: [Major, Erica \(BOS\)](#)
Cc: [Walton, Shamann \(BOS\)](#); [Board of Supervisors, \(BOS\)](#); [Preston, Dean \(BOS\)](#); [Peskin, Aaron \(BOS\)](#); [Safai, Ahsha \(BOS\)](#)
Subject: Public Comment Re: BoS File 200701
Date: Thursday, September 17, 2020 4:23:33 PM

This message is from outside the City email system. Do not open links or attachments from untrusted sources.

Dear Supervisors,

I'm a resident of San Francisco writing to strongly support prohibiting gas in new construction. The methane leaks, air pollution, and explosion dangers of natural gas are no longer necessary for the functioning of our homes and businesses. San Francisco can lead the state and the country in building a better future.

In addition to recommending the ordinance, I would also like to ask the Commission to recommend the changes to the ordinance as laid out by Earthjustice, the Sierra Club, the San Francisco Climate Emergency Coalition, and other local groups in their letter to the Commission and Board.

It is important to me that we:

1. Eliminate the feasibility exception to the electric-ready requirement and make fully electric-ready construction a baseline requirement for new construction. We know that the future is electric. Allowing any building to be built that will require massive retrofits in the near future is unacceptable. With full electric readiness, we minimize that retrofit cost.
2. Create a Clean Energy Building Hub through the City and County of San Francisco that provides for the outreach, resources, and education needed to eliminate barriers and maximize opportunity for all-electric new construction to benefit both climate and equity.
3. Expand the ordinance's definition of "mixed-fuel buildings" to include laboratory, industrial, and decorative uses of gas. Gas shouldn't be allowed for upscale decorative uses. It's wrong to harm public health for private enjoyment.
4. Provide additional limitations and transparency in the exemption process to ensure any project found exempt for infeasibility is truly in the public interest. I'm concerned about the news of powerful and connected people being able to get favors from DBI. We need sunshine on the exemption process, and exemptions should only be given in the public interest.
5. Amend section 106A.1.17 to require that the Building Official find "sufficient evidence was submitted to substantiate the infeasibility of an All-Electric Building or Project design without regard to financial, floor-area, or amenity-related loss unless

deemed to be in the public welfare." The housing crisis is real. And we need to find ways of fixing it without sacrificing our children's future. The space taken up by a transformer should not be an acceptable reason for an exemption.

6. Eliminate the blanket exemption for commercial kitchens delaying compliance until 2022. Existing restaurants are not helped by giving builders a pass on making future commercial kitchens all-electric.

Thank you for taking up this important issue and considering the health and safety of our residents and climate.

Sincerely,

Lucy Duan

210 Arkansas St San Francisco

--

Lucy Duan

yunxiduan@gmail.com

+1 (773) 510 7728



September 21, 2020

Erica Major
Assistant Clerk
Land Use and Transportation Committee
San Francisco Board of Supervisors
1455 Market Street, Suite 1200
San Francisco, CA 94103
Erica.Major@sfgov.org

Re: File #200701 – All-Electric New Construction Ordinance

Dear Ms. Major,

On behalf of Earthjustice, I submit the following letters from Earthjustice supporters urging the San Francisco Board of Supervisors to approve an all-electric building standard for all new construction in the City of San Francisco. The devastating consequences of decades of obstruction by the fossil fuel industry on meaningful measures to address the climate crisis are now upon us. The time has arrived to take comprehensive, decisive action to protect the health and safety of our communities and to significantly reduce our city's contributions to the climate crisis. Thank you for your consideration of these letters, and for moving forward with this crucial policy.

Sincerely,

Rebecca Barker
Associate Attorney
Earthjustice

CC: Board.of.Supervisors@sfgov.org

From: [Rebecca Barker](#)
To: [Major, Erica \(BOS\); Board of Supervisors, \(BOS\)](#)
Subject: File No. 200701 Public Comments from 71 SF Residents
Date: Monday, September 21, 2020 9:35:05 AM
Attachments: [ATT00001.png](#)
[Attachment A Messages from Earthjustice Supporters on SF All Electric Ordinance.pdf](#)
[Cover Letter SF Residents Support for 200701.pdf](#)

This message is from outside the City email system. Do not open links or attachments from untrusted sources.

Hello,

Please find attached cover letter and Attachment A, which includes letters from 71 San Francisco residents in support of a comprehensive all-electric new construction ordinance for the City of San Francisco. Please add these documents to the record for Board File Number 200701.

Thank you,
Rebecca Barker

Rebecca Barker
She/her/hers
Associate Attorney
Clean Energy Program
50 California Street, Suite 500
San Francisco, CA 94111
Phone: 415.217.2056
rbarker@earthjustice.org



The information contained in this email message may be privileged, confidential and protected from disclosure. If you are not the intended recipient, any dissemination, distribution or copying is strictly prohibited. If you think that you have received this email message in error, please notify the sender by reply email and delete the message and any attachments.

-- Sent from **Kyle Berquist** to **Supervisor Dean Preston** on Sep 15, 2020 --

My name is Kyle Berquist, and as your constituent I urge you to support Supervisor Mandelman's proposed ordinance requiring all-electric buildings for new construction. Support for this ordinance is strong in my neighborhood, as we strongly believe that the Board of Supervisors needs to do everything it can to protect public health and reduce carbon emissions. This issue is personal to me because

The health and climate impacts of continued natural gas use are severe. Children are 42% more likely to develop asthma in homes with gas stoves compared to homes without gas stoves. It's not just asthma -- studies show that replacing gas appliances with electric versions would save hundreds of lives annually in California. We need San Francisco to be a leader on this issue that the rest of the state can follow.

Natural gas combustion in buildings is responsible for a large portion of our city's carbon emissions, which is why we can't afford to delay. Fully electrifying a single house can reduce its carbon emissions by up to 90% depending on how clean the grid is. We are lucky in San Francisco to get most of our energy from carbon-free sources, meaning we get more bang for our buck when we electrify our homes.

While I am in full support of this ordinance, I ask that, to more fully realize the health, climate and economic benefits of electrification and ensure that any exemptions to this important requirement are under legitimately exceptional circumstances, the following changes be made to strengthen the ordinance and implementing regulations:

- 1) eliminate the feasibility exception to the electric-ready requirement;
- 2) create a Clean Energy Buildings Hub that evaluates equity and economic considerations and informs the creation of additional education and technical support resources for affected groups (e.g., small businesses, restaurants, affordable housing, contractors, workforce standards), maximizing opportunities and eliminating barriers to utilization of all-electric new construction to address climate and equity;
- 3) expand and clarify the definition of "Mixed-Fuel Buildings" in the ordinance to include laboratory and industrial buildings, as well as decorative uses of gas;
- 4) provide additional limitations and transparency in the exemption process to ensure any project found exempt for infeasibility is truly in the public interest; and
- 5) eliminate the blanket exemption for commercial kitchens delaying compliance until 2022;

California is burning and our air is unbreathable. There is no more time -- we need bold climate action now. Every building that goes up in San Francisco with gas hookups is just one more building we will have to retrofit for electric heating and appliances later. The prudent thing to do - for our climate, health, and wallets -- is to make sure we aren't digging a deeper hole for ourselves and enact the strongest building electrification ordinance possible. Please support Supervisor Mandelman's ordinance and make San Francisco a climate action leader.

Regards,
Kyle Berquist
1338 Haight St
San Francisco, CA 94117

-- Sent from **Anna Shurter** to **Supervisor Catherine Stefani** on Sep 16, 2020 --

My name is Anna Shurter, and as your constituent I urge you to support Supervisor Mandelman's proposed ordinance requiring all-electric buildings for new construction. Support for this ordinance is strong in my neighborhood, as we strongly believe that the Board of Supervisors needs to do everything it can to protect public health and reduce carbon emissions. This issue is personal to me because

The health and climate impacts of continued natural gas use are severe. Children are 42% more likely to develop asthma in homes with gas stoves compared to homes without gas stoves. It's not just asthma -- studies show that replacing gas appliances with electric versions would save hundreds of lives annually in California. We need San Francisco to be a leader on this issue that the rest of the state can follow.

Natural gas combustion in buildings is responsible for a large portion of our city's carbon emissions, which is why we can't afford to delay. Fully electrifying a single house can reduce its carbon emissions by up to 90% depending on how clean the grid is. We are lucky in San Francisco to get most of our energy from carbon-free sources, meaning we get more bang for our buck when we electrify our homes.

While I am in full support of this ordinance, I ask that, to more fully realize the health, climate and economic benefits of electrification and ensure that any exemptions to this important requirement are under legitimately exceptional circumstances, the following changes be made to strengthen the ordinance and implementing regulations:

- 1) eliminate the feasibility exception to the electric-ready requirement;
- 2) create a Clean Energy Buildings Hub that evaluates equity and economic considerations and informs the creation of additional education and technical support resources for affected groups (e.g., small businesses, restaurants, affordable housing, contractors, workforce standards), maximizing opportunities and eliminating barriers to utilization of all-electric new construction to address climate and equity;
- 3) expand and clarify the definition of "Mixed-Fuel Buildings" in the ordinance to include laboratory and industrial buildings, as well as decorative uses of gas;
- 4) provide additional limitations and transparency in the exemption process to ensure any project found exempt for infeasibility is truly in the public interest; and
- 5) eliminate the blanket exemption for commercial kitchens delaying compliance until 2022;

California is burning and our air is unbreathable. There is no more time -- we need bold climate action now. Every building that goes up in San Francisco with gas hookups is just one more building we will have to retrofit for electric heating and appliances later. The prudent thing to do - for our climate, health, and wallets -- is to make sure we aren't digging a deeper hole for ourselves and enact the strongest building electrification ordinance possible. Please support Supervisor Mandelman's ordinance and make San Francisco a climate action leader.

Regards,
Anna Shurter
306 Avila St
San Francisco, CA 94123

-- Sent from **Robert Cambra** to **Supervisor Rafael Mandelman** on Sep 16, 2020 --

My name is Robert Cambra, and as your constituent I urge you to support Supervisor Mandelman's proposed ordinance requiring all-electric buildings for new construction. Support for this ordinance is strong in my neighborhood, as we strongly believe that the Board of Supervisors needs to do everything it can to protect public health and reduce carbon emissions. This issue is personal to me because

The health and climate impacts of continued natural gas use are severe. Children are 42% more likely to develop asthma in homes with gas stoves compared to homes without gas stoves. It's not just asthma -- studies show that replacing gas appliances with electric versions would save hundreds of lives annually in California. We need San Francisco to be a leader on this issue that the rest of the state can follow.

Natural gas combustion in buildings is responsible for a large portion of our city's carbon emissions, which is why we can't afford to delay. Fully electrifying a single house can reduce its carbon emissions by up to 90% depending on how clean the grid is. We are lucky in San Francisco to get most of our energy from carbon-free sources, meaning we get more bang for our buck when we electrify our homes.

While I am in full support of this ordinance, I ask that, to more fully realize the health, climate and economic benefits of electrification and ensure that any exemptions to this important requirement are under legitimately exceptional circumstances, the following changes be made to strengthen the ordinance and implementing regulations:

- 1) eliminate the feasibility exception to the electric-ready requirement;
- 2) create a Clean Energy Buildings Hub that evaluates equity and economic considerations and informs the creation of additional education and technical support resources for affected groups (e.g., small businesses, restaurants, affordable housing, contractors, workforce standards), maximizing opportunities and eliminating barriers to utilization of all-electric new construction to address climate and equity;
- 3) expand and clarify the definition of "Mixed-Fuel Buildings" in the ordinance to include laboratory and industrial buildings, as well as decorative uses of gas;
- 4) provide additional limitations and transparency in the exemption process to ensure any project found exempt for infeasibility is truly in the public interest; and
- 5) eliminate the blanket exemption for commercial kitchens delaying compliance until 2022;

California is burning and our air is unbreathable. There is no more time -- we need bold climate action now. Every building that goes up in San Francisco with gas hookups is just one more building we will have to retrofit for electric heating and appliances later. The prudent thing to do - for our climate, health, and wallets -- is to make sure we aren't digging a deeper hole for ourselves and enact the strongest building electrification ordinance possible. Please support Supervisor Mandelman's ordinance and make San Francisco a climate action leader.

Regards,
Robert Cambra
265 Glenview Dr
San Francisco, CA 94131

-- Sent from **Mike Andrewjeski** to **Supervisor Sandra Fewer** on Sep 16, 2020 --

My name is Mike Andrewjeski, and as your constituent I urge you to support Supervisor Mandelman's proposed ordinance requiring all-electric buildings for new construction. Support for this ordinance is strong in my neighborhood, as we strongly believe that the Board of Supervisors needs to do everything it can to protect public health and reduce carbon emissions. This issue is personal to me because

The health and climate impacts of continued natural gas use are severe. Children are 42% more likely to develop asthma in homes with gas stoves compared to homes without gas stoves. It's not just asthma -- studies show that replacing gas appliances with electric versions would save hundreds of lives annually in California. We need San Francisco to be a leader on this issue that the rest of the state can follow.

Natural gas combustion in buildings is responsible for a large portion of our city's carbon emissions, which is why we can't afford to delay. Fully electrifying a single house can reduce its carbon emissions by up to 90% depending on how clean the grid is. We are lucky in San Francisco to get most of our energy from carbon-free sources, meaning we get more bang for our buck when we electrify our homes.

While I am in full support of this ordinance, I ask that, to more fully realize the health, climate and economic benefits of electrification and ensure that any exemptions to this important requirement are under legitimately exceptional circumstances, the following changes be made to strengthen the ordinance and implementing regulations:

- 1) eliminate the feasibility exception to the electric-ready requirement;
- 2) create a Clean Energy Buildings Hub that evaluates equity and economic considerations and informs the creation of additional education and technical support resources for affected groups (e.g., small businesses, restaurants, affordable housing, contractors, workforce standards), maximizing opportunities and eliminating barriers to utilization of all-electric new construction to address climate and equity;
- 3) expand and clarify the definition of "Mixed-Fuel Buildings" in the ordinance to include laboratory and industrial buildings, as well as decorative uses of gas;
- 4) provide additional limitations and transparency in the exemption process to ensure any project found exempt for infeasibility is truly in the public interest; and
- 5) eliminate the blanket exemption for commercial kitchens delaying compliance until 2022;

California is burning and our air is unbreathable. There is no more time -- we need bold climate action now. Every building that goes up in San Francisco with gas hookups is just one more building we will have to retrofit for electric heating and appliances later. The prudent thing to do - for our climate, health, and wallets -- is to make sure we aren't digging a deeper hole for ourselves and enact the strongest building electrification ordinance possible. Please support Supervisor Mandelman's ordinance and make San Francisco a climate action leader.

Regards,
Mike Andrewjeski
442 44th Ave
San Francisco, CA 94121

-- Sent from **Carly Quaglio** to **Supervisor Dean Preston** on Sep 16, 2020 --

My name is Carly Quaglio, and as your constituent I urge you to support Supervisor Mandelman's proposed ordinance requiring all-electric buildings for new construction. Support for this ordinance is strong in my neighborhood, as we strongly believe that the Board of Supervisors needs to do everything it can to protect public health and reduce carbon emissions. This issue is personal to me because

The health and climate impacts of continued natural gas use are severe. Children are 42% more likely to develop asthma in homes with gas stoves compared to homes without gas stoves. It's not just asthma -- studies show that replacing gas appliances with electric versions would save hundreds of lives annually in California. We need San Francisco to be a leader on this issue that the rest of the state can follow.

Natural gas combustion in buildings is responsible for a large portion of our city's carbon emissions, which is why we can't afford to delay. Fully electrifying a single house can reduce its carbon emissions by up to 90% depending on how clean the grid is. We are lucky in San Francisco to get most of our energy from carbon-free sources, meaning we get more bang for our buck when we electrify our homes.

While I am in full support of this ordinance, I ask that, to more fully realize the health, climate and economic benefits of electrification and ensure that any exemptions to this important requirement are under legitimately exceptional circumstances, the following changes be made to strengthen the ordinance and implementing regulations:

- 1) eliminate the feasibility exception to the electric-ready requirement;
- 2) create a Clean Energy Buildings Hub that evaluates equity and economic considerations and informs the creation of additional education and technical support resources for affected groups (e.g., small businesses, restaurants, affordable housing, contractors, workforce standards), maximizing opportunities and eliminating barriers to utilization of all-electric new construction to address climate and equity;
- 3) expand and clarify the definition of "Mixed-Fuel Buildings" in the ordinance to include laboratory and industrial buildings, as well as decorative uses of gas;
- 4) provide additional limitations and transparency in the exemption process to ensure any project found exempt for infeasibility is truly in the public interest; and
- 5) eliminate the blanket exemption for commercial kitchens delaying compliance until 2022;

California is burning and our air is unbreathable. There is no more time -- we need bold climate action now. Every building that goes up in San Francisco with gas hookups is just one more building we will have to retrofit for electric heating and appliances later. The prudent thing to do - for our climate, health, and wallets -- is to make sure we aren't digging a deeper hole for ourselves and enact the strongest building electrification ordinance possible. Please support Supervisor Mandelman's ordinance and make San Francisco a climate action leader.

Regards,
Carly Quaglio
16790 Watson Rd
Guerneville, CA 95446

-- Sent from **eugenio jardim** to **Supervisor Matt Haney** on Sep 16, 2020 --

My name is eugenio jardim, and as your constituent I urge you to support Supervisor Mandelman's proposed ordinance requiring all-electric buildings for new construction. Support for this ordinance is strong in my neighborhood, as we strongly believe that the Board of Supervisors needs to do everything it can to protect public health and reduce carbon emissions. This issue is personal to me because

The health and climate impacts of continued natural gas use are severe. Children are 42% more likely to develop asthma in homes with gas stoves compared to homes without gas stoves. It's not just asthma -- studies show that replacing gas appliances with electric versions would save hundreds of lives annually in California. We need San Francisco to be a leader on this issue that the rest of the state can follow.

Natural gas combustion in buildings is responsible for a large portion of our city's carbon emissions, which is why we can't afford to delay. Fully electrifying a single house can reduce its carbon emissions by up to 90% depending on how clean the grid is. We are lucky in San Francisco to get most of our energy from carbon-free sources, meaning we get more bang for our buck when we electrify our homes.

While I am in full support of this ordinance, I ask that, to more fully realize the health, climate and economic benefits of electrification and ensure that any exemptions to this important requirement are under legitimately exceptional circumstances, the following changes be made to strengthen the ordinance and implementing regulations:

- 1) eliminate the feasibility exception to the electric-ready requirement;
- 2) create a Clean Energy Buildings Hub that evaluates equity and economic considerations and informs the creation of additional education and technical support resources for affected groups (e.g., small businesses, restaurants, affordable housing, contractors, workforce standards), maximizing opportunities and eliminating barriers to utilization of all-electric new construction to address climate and equity;
- 3) expand and clarify the definition of "Mixed-Fuel Buildings" in the ordinance to include laboratory and industrial buildings, as well as decorative uses of gas;
- 4) provide additional limitations and transparency in the exemption process to ensure any project found exempt for infeasibility is truly in the public interest; and
- 5) eliminate the blanket exemption for commercial kitchens delaying compliance until 2022;

California is burning and our air is unbreathable. There is no more time -- we need bold climate action now. Every building that goes up in San Francisco with gas hookups is just one more building we will have to retrofit for electric heating and appliances later. The prudent thing to do - for our climate, health, and wallets -- is to make sure we aren't digging a deeper hole for ourselves and enact the strongest building electrification ordinance possible. Please support Supervisor Mandelman's ordinance and make San Francisco a climate action leader.

Regards,
eugenio jardim
95 McCoppin St
San Francisco, CA 94103

-- Sent from **William Werle** to **Supervisor Gordon Mar** on Sep 16, 2020 --

My name is William Werle, and as your constituent I urge you to support Supervisor Mandelman's proposed ordinance requiring all-electric buildings for new construction. Support for this ordinance is strong in my neighborhood, as we strongly believe that the Board of Supervisors needs to do everything it can to protect public health and reduce carbon emissions. This issue is personal to me because

The health and climate impacts of continued natural gas use are severe. Children are 42% more likely to develop asthma in homes with gas stoves compared to homes without gas stoves. It's not just asthma -- studies show that replacing gas appliances with electric versions would save hundreds of lives annually in California. We need San Francisco to be a leader on this issue that the rest of the state can follow.

Natural gas combustion in buildings is responsible for a large portion of our city's carbon emissions, which is why we can't afford to delay. Fully electrifying a single house can reduce its carbon emissions by up to 90% depending on how clean the grid is. We are lucky in San Francisco to get most of our energy from carbon-free sources, meaning we get more bang for our buck when we electrify our homes.

While I am in full support of this ordinance, I ask that, to more fully realize the health, climate and economic benefits of electrification and ensure that any exemptions to this important requirement are under legitimately exceptional circumstances, the following changes be made to strengthen the ordinance and implementing regulations:

- 1) eliminate the feasibility exception to the electric-ready requirement;
- 2) create a Clean Energy Buildings Hub that evaluates equity and economic considerations and informs the creation of additional education and technical support resources for affected groups (e.g., small businesses, restaurants, affordable housing, contractors, workforce standards), maximizing opportunities and eliminating barriers to utilization of all-electric new construction to address climate and equity;
- 3) expand and clarify the definition of "Mixed-Fuel Buildings" in the ordinance to include laboratory and industrial buildings, as well as decorative uses of gas;
- 4) provide additional limitations and transparency in the exemption process to ensure any project found exempt for infeasibility is truly in the public interest; and
- 5) eliminate the blanket exemption for commercial kitchens delaying compliance until 2022;

California is burning and our air is unbreathable. There is no more time -- we need bold climate action now. Every building that goes up in San Francisco with gas hookups is just one more building we will have to retrofit for electric heating and appliances later. The prudent thing to do - for our climate, health, and wallets -- is to make sure we aren't digging a deeper hole for ourselves and enact the strongest building electrification ordinance possible. Please support Supervisor Mandelman's ordinance and make San Francisco a climate action leader.

Regards,
William Werle
1615 44th Ave
San Francisco, CA 94122

-- Sent from **Charles Calhoun** to **Supervisor Catherine Stefani** on Sep 16, 2020 --

My name is Charles Calhoun, and as your constituent I urge you to support Supervisor Mandelman's proposed ordinance requiring all-electric buildings for new construction. Support for this ordinance is strong in my neighborhood, as we strongly believe that the Board of Supervisors needs to do everything it can to protect public health and reduce carbon emissions. This issue is personal to me because

The health and climate impacts of continued natural gas use are severe. Children are 42% more likely to develop asthma in homes with gas stoves compared to homes without gas stoves. It's not just asthma -- studies show that replacing gas appliances with electric versions would save hundreds of lives annually in California. We need San Francisco to be a leader on this issue that the rest of the state can follow.

Natural gas combustion in buildings is responsible for a large portion of our city's carbon emissions, which is why we can't afford to delay. Fully electrifying a single house can reduce its carbon emissions by up to 90% depending on how clean the grid is. We are lucky in San Francisco to get most of our energy from carbon-free sources, meaning we get more bang for our buck when we electrify our homes.

While I am in full support of this ordinance, I ask that, to more fully realize the health, climate and economic benefits of electrification and ensure that any exemptions to this important requirement are under legitimately exceptional circumstances, the following changes be made to strengthen the ordinance and implementing regulations:

- 1) eliminate the feasibility exception to the electric-ready requirement;
- 2) create a Clean Energy Buildings Hub that evaluates equity and economic considerations and informs the creation of additional education and technical support resources for affected groups (e.g., small businesses, restaurants, affordable housing, contractors, workforce standards), maximizing opportunities and eliminating barriers to utilization of all-electric new construction to address climate and equity;
- 3) expand and clarify the definition of "Mixed-Fuel Buildings" in the ordinance to include laboratory and industrial buildings, as well as decorative uses of gas;
- 4) provide additional limitations and transparency in the exemption process to ensure any project found exempt for infeasibility is truly in the public interest; and
- 5) eliminate the blanket exemption for commercial kitchens delaying compliance until 2022;

California is burning and our air is unbreathable. There is no more time -- we need bold climate action now. Every building that goes up in San Francisco with gas hookups is just one more building we will have to retrofit for electric heating and appliances later. The prudent thing to do - for our climate, health, and wallets -- is to make sure we aren't digging a deeper hole for ourselves and enact the strongest building electrification ordinance possible. Please support Supervisor Mandelman's ordinance and make San Francisco a climate action leader.

Regards,
Charles Calhoun
2459 Post St
San Francisco, CA 94115

-- Sent from **Gregory Coyle** to **Supervisor Rafael Mandelman** on Sep 16, 2020 --

My name is Gregory Coyle, and as your constituent I urge you to support Supervisor Mandelman's proposed ordinance requiring all-electric buildings for new construction. Support for this ordinance is strong in my neighborhood, as we strongly believe that the Board of Supervisors needs to do everything it can to protect public health and reduce carbon emissions. This issue is personal to me because

The health and climate impacts of continued natural gas use are severe. Children are 42% more likely to develop asthma in homes with gas stoves compared to homes without gas stoves. It's not just asthma -- studies show that replacing gas appliances with electric versions would save hundreds of lives annually in California. We need San Francisco to be a leader on this issue that the rest of the state can follow.

Natural gas combustion in buildings is responsible for a large portion of our city's carbon emissions, which is why we can't afford to delay. Fully electrifying a single house can reduce its carbon emissions by up to 90% depending on how clean the grid is. We are lucky in San Francisco to get most of our energy from carbon-free sources, meaning we get more bang for our buck when we electrify our homes.

While I am in full support of this ordinance, I ask that, to more fully realize the health, climate and economic benefits of electrification and ensure that any exemptions to this important requirement are under legitimately exceptional circumstances, the following changes be made to strengthen the ordinance and implementing regulations:

- 1) eliminate the feasibility exception to the electric-ready requirement;
- 2) create a Clean Energy Buildings Hub that evaluates equity and economic considerations and informs the creation of additional education and technical support resources for affected groups (e.g., small businesses, restaurants, affordable housing, contractors, workforce standards), maximizing opportunities and eliminating barriers to utilization of all-electric new construction to address climate and equity;
- 3) expand and clarify the definition of "Mixed-Fuel Buildings" in the ordinance to include laboratory and industrial buildings, as well as decorative uses of gas;
- 4) provide additional limitations and transparency in the exemption process to ensure any project found exempt for infeasibility is truly in the public interest; and
- 5) eliminate the blanket exemption for commercial kitchens delaying compliance until 2022;

California is burning and our air is unbreathable. There is no more time -- we need bold climate action now. Every building that goes up in San Francisco with gas hookups is just one more building we will have to retrofit for electric heating and appliances later. The prudent thing to do - for our climate, health, and wallets -- is to make sure we aren't digging a deeper hole for ourselves and enact the strongest building electrification ordinance possible. Please support Supervisor Mandelman's ordinance and make San Francisco a climate action leader.

Regards,
Gregory Coyle
14 Ford St
San Francisco, CA 94114

-- Sent from **Ivan Rhudick** to **Supervisor Sandra Fewer** on Sep 16, 2020 --

My name is Ivan Rhudick, and as your constituent I urge you to support Supervisor Mandelman's proposed ordinance requiring all-electric buildings for new construction. Support for this ordinance is strong in my neighborhood, as we strongly believe that the Board of Supervisors needs to do everything it can to protect public health and reduce carbon emissions. This issue is personal to me because

The health and climate impacts of continued natural gas use are severe. Children are 42% more likely to develop asthma in homes with gas stoves compared to homes without gas stoves. It's not just asthma -- studies show that replacing gas appliances with electric versions would save hundreds of lives annually in California. We need San Francisco to be a leader on this issue that the rest of the state can follow.

Natural gas combustion in buildings is responsible for a large portion of our city's carbon emissions, which is why we can't afford to delay. Fully electrifying a single house can reduce its carbon emissions by up to 90% depending on how clean the grid is. We are lucky in San Francisco to get most of our energy from carbon-free sources, meaning we get more bang for our buck when we electrify our homes.

While I am in full support of this ordinance, I ask that, to more fully realize the health, climate and economic benefits of electrification and ensure that any exemptions to this important requirement are under legitimately exceptional circumstances, the following changes be made to strengthen the ordinance and implementing regulations:

- 1) eliminate the feasibility exception to the electric-ready requirement;
- 2) create a Clean Energy Buildings Hub that evaluates equity and economic considerations and informs the creation of additional education and technical support resources for affected groups (e.g., small businesses, restaurants, affordable housing, contractors, workforce standards), maximizing opportunities and eliminating barriers to utilization of all-electric new construction to address climate and equity;
- 3) expand and clarify the definition of "Mixed-Fuel Buildings" in the ordinance to include laboratory and industrial buildings, as well as decorative uses of gas;
- 4) provide additional limitations and transparency in the exemption process to ensure any project found exempt for infeasibility is truly in the public interest; and
- 5) eliminate the blanket exemption for commercial kitchens delaying compliance until 2022;

California is burning and our air is unbreathable. There is no more time -- we need bold climate action now. Every building that goes up in San Francisco with gas hookups is just one more building we will have to retrofit for electric heating and appliances later. The prudent thing to do - for our climate, health, and wallets -- is to make sure we aren't digging a deeper hole for ourselves and enact the strongest building electrification ordinance possible. Please support Supervisor Mandelman's ordinance and make San Francisco a climate action leader.

Regards,
Ivan Rhudick
251 5th Ave
San Francisco, CA 94118

-- Sent from **Jerushah Ismail** to **Supervisor Aaron Peskin** on Sep 16, 2020 --

My name is Jerushah Ismail, and as your constituent I urge you to support Supervisor Mandelman's proposed ordinance requiring all-electric buildings for new construction. Support for this ordinance is strong in my neighborhood, as we strongly believe that the Board of Supervisors needs to do everything it can to protect public health and reduce carbon emissions. This issue is personal to me because

The health and climate impacts of continued natural gas use are severe. Children are 42% more likely to develop asthma in homes with gas stoves compared to homes without gas stoves. It's not just asthma -- studies show that replacing gas appliances with electric versions would save hundreds of lives annually in California. We need San Francisco to be a leader on this issue that the rest of the state can follow.

Natural gas combustion in buildings is responsible for a large portion of our city's carbon emissions, which is why we can't afford to delay. Fully electrifying a single house can reduce its carbon emissions by up to 90% depending on how clean the grid is. We are lucky in San Francisco to get most of our energy from carbon-free sources, meaning we get more bang for our buck when we electrify our homes.

While I am in full support of this ordinance, I ask that, to more fully realize the health, climate and economic benefits of electrification and ensure that any exemptions to this important requirement are under legitimately exceptional circumstances, the following changes be made to strengthen the ordinance and implementing regulations:

- 1) eliminate the feasibility exception to the electric-ready requirement;
- 2) create a Clean Energy Buildings Hub that evaluates equity and economic considerations and informs the creation of additional education and technical support resources for affected groups (e.g., small businesses, restaurants, affordable housing, contractors, workforce standards), maximizing opportunities and eliminating barriers to utilization of all-electric new construction to address climate and equity;
- 3) expand and clarify the definition of "Mixed-Fuel Buildings" in the ordinance to include laboratory and industrial buildings, as well as decorative uses of gas;
- 4) provide additional limitations and transparency in the exemption process to ensure any project found exempt for infeasibility is truly in the public interest; and
- 5) eliminate the blanket exemption for commercial kitchens delaying compliance until 2022;

California is burning and our air is unbreathable. There is no more time -- we need bold climate action now. Every building that goes up in San Francisco with gas hookups is just one more building we will have to retrofit for electric heating and appliances later. The prudent thing to do - for our climate, health, and wallets -- is to make sure we aren't digging a deeper hole for ourselves and enact the strongest building electrification ordinance possible. Please support Supervisor Mandelman's ordinance and make San Francisco a climate action leader.

Regards,
Jerushah Ismail
1765 Mason St
San Francisco, CA 94133

-- Sent from **Brittney Oconnor** to **Supervisor Ahsha Safai** on Sep 16, 2020 --

My name is Brittney Oconnor, and as your constituent I urge you to support Supervisor Mandelman's proposed ordinance requiring all-electric buildings for new construction. Support for this ordinance is strong in my neighborhood, as we strongly believe that the Board of Supervisors needs to do everything it can to protect public health and reduce carbon emissions. This issue is personal to me because

The health and climate impacts of continued natural gas use are severe. Children are 42% more likely to develop asthma in homes with gas stoves compared to homes without gas stoves. It's not just asthma -- studies show that replacing gas appliances with electric versions would save hundreds of lives annually in California. We need San Francisco to be a leader on this issue that the rest of the state can follow.

Natural gas combustion in buildings is responsible for a large portion of our city's carbon emissions, which is why we can't afford to delay. Fully electrifying a single house can reduce its carbon emissions by up to 90% depending on how clean the grid is. We are lucky in San Francisco to get most of our energy from carbon-free sources, meaning we get more bang for our buck when we electrify our homes.

While I am in full support of this ordinance, I ask that, to more fully realize the health, climate and economic benefits of electrification and ensure that any exemptions to this important requirement are under legitimately exceptional circumstances, the following changes be made to strengthen the ordinance and implementing regulations:

- 1) eliminate the feasibility exception to the electric-ready requirement;
- 2) create a Clean Energy Buildings Hub that evaluates equity and economic considerations and informs the creation of additional education and technical support resources for affected groups (e.g., small businesses, restaurants, affordable housing, contractors, workforce standards), maximizing opportunities and eliminating barriers to utilization of all-electric new construction to address climate and equity;
- 3) expand and clarify the definition of "Mixed-Fuel Buildings" in the ordinance to include laboratory and industrial buildings, as well as decorative uses of gas;
- 4) provide additional limitations and transparency in the exemption process to ensure any project found exempt for infeasibility is truly in the public interest; and
- 5) eliminate the blanket exemption for commercial kitchens delaying compliance until 2022;

California is burning and our air is unbreathable. There is no more time -- we need bold climate action now. Every building that goes up in San Francisco with gas hookups is just one more building we will have to retrofit for electric heating and appliances later. The prudent thing to do - for our climate, health, and wallets -- is to make sure we aren't digging a deeper hole for ourselves and enact the strongest building electrification ordinance possible. Please support Supervisor Mandelman's ordinance and make San Francisco a climate action leader.

Regards,
Brittney Oconnor
375 Trumbull St
San Francisco, CA 94112

-- Sent from **Kathryn Hyde** to **Supervisor Sandra Fewer** on Sep 16, 2020 --

My name is Kathryn Hyde, and as your constituent I urge you to support Supervisor Mandelman's proposed ordinance requiring all-electric buildings for new construction. Support for this ordinance is strong in my neighborhood, as we strongly believe that the Board of Supervisors needs to do everything it can to protect public health and reduce carbon emissions. This issue is personal to me because

The health and climate impacts of continued natural gas use are severe. Children are 42% more likely to develop asthma in homes with gas stoves compared to homes without gas stoves. It's not just asthma -- studies show that replacing gas appliances with electric versions would save hundreds of lives annually in California. We need San Francisco to be a leader on this issue that the rest of the state can follow.

Natural gas combustion in buildings is responsible for a large portion of our city's carbon emissions, which is why we can't afford to delay. Fully electrifying a single house can reduce its carbon emissions by up to 90% depending on how clean the grid is. We are lucky in San Francisco to get most of our energy from carbon-free sources, meaning we get more bang for our buck when we electrify our homes.

While I am in full support of this ordinance, I ask that, to more fully realize the health, climate and economic benefits of electrification and ensure that any exemptions to this important requirement are under legitimately exceptional circumstances, the following changes be made to strengthen the ordinance and implementing regulations:

- 1) eliminate the feasibility exception to the electric-ready requirement;
- 2) create a Clean Energy Buildings Hub that evaluates equity and economic considerations and informs the creation of additional education and technical support resources for affected groups (e.g., small businesses, restaurants, affordable housing, contractors, workforce standards), maximizing opportunities and eliminating barriers to utilization of all-electric new construction to address climate and equity;
- 3) expand and clarify the definition of "Mixed-Fuel Buildings" in the ordinance to include laboratory and industrial buildings, as well as decorative uses of gas;
- 4) provide additional limitations and transparency in the exemption process to ensure any project found exempt for infeasibility is truly in the public interest; and
- 5) eliminate the blanket exemption for commercial kitchens delaying compliance until 2022;

California is burning and our air is unbreathable. There is no more time -- we need bold climate action now. Every building that goes up in San Francisco with gas hookups is just one more building we will have to retrofit for electric heating and appliances later. The prudent thing to do - for our climate, health, and wallets -- is to make sure we aren't digging a deeper hole for ourselves and enact the strongest building electrification ordinance possible. Please support Supervisor Mandelman's ordinance and make San Francisco a climate action leader.

Regards,
Kathryn Hyde
4611 California St
San Francisco, CA 94118

-- Sent from **Libby Ingalls** to **Supervisor Catherine Stefani** on Sep 16, 2020 --

My name is Libby Ingalls, and as your constituent I urge you to support Supervisor Mandelman's proposed ordinance requiring all-electric buildings for new construction. Support for this ordinance is strong in my neighborhood, as we strongly believe that the Board of Supervisors needs to do everything it can to protect public health and reduce carbon emissions. This issue is personal to me because

The health and climate impacts of continued natural gas use are severe. Children are 42% more likely to develop asthma in homes with gas stoves compared to homes without gas stoves. It's not just asthma -- studies show that replacing gas appliances with electric versions would save hundreds of lives annually in California. We need San Francisco to be a leader on this issue that the rest of the state can follow.

Natural gas combustion in buildings is responsible for a large portion of our city's carbon emissions, which is why we can't afford to delay. Fully electrifying a single house can reduce its carbon emissions by up to 90% depending on how clean the grid is. We are lucky in San Francisco to get most of our energy from carbon-free sources, meaning we get more bang for our buck when we electrify our homes.

While I am in full support of this ordinance, I ask that, to more fully realize the health, climate and economic benefits of electrification and ensure that any exemptions to this important requirement are under legitimately exceptional circumstances, the following changes be made to strengthen the ordinance and implementing regulations:

- 1) eliminate the feasibility exception to the electric-ready requirement;
- 2) create a Clean Energy Buildings Hub that evaluates equity and economic considerations and informs the creation of additional education and technical support resources for affected groups (e.g., small businesses, restaurants, affordable housing, contractors, workforce standards), maximizing opportunities and eliminating barriers to utilization of all-electric new construction to address climate and equity;
- 3) expand and clarify the definition of "Mixed-Fuel Buildings" in the ordinance to include laboratory and industrial buildings, as well as decorative uses of gas;
- 4) provide additional limitations and transparency in the exemption process to ensure any project found exempt for infeasibility is truly in the public interest; and
- 5) eliminate the blanket exemption for commercial kitchens delaying compliance until 2022;

California is burning and our air is unbreathable. There is no more time -- we need bold climate action now. Every building that goes up in San Francisco with gas hookups is just one more building we will have to retrofit for electric heating and appliances later. The prudent thing to do - for our climate, health, and wallets -- is to make sure we aren't digging a deeper hole for ourselves and enact the strongest building electrification ordinance possible. Please support Supervisor Mandelman's ordinance and make San Francisco a climate action leader.

Regards,
Libby Ingalls
2565 Washington St
San Francisco, CA 94115

-- Sent from **nick wolf** to **Supervisor Sandra Fewer** on Sep 16, 2020 --

My name is nick wolf, and as your constituent I urge you to support Supervisor Mandelman's proposed ordinance requiring all-electric buildings for new construction. Support for this ordinance is strong in my neighborhood, as we strongly believe that the Board of Supervisors needs to do everything it can to protect public health and reduce carbon emissions. This issue is personal to me because

The health and climate impacts of continued natural gas use are severe. Children are 42% more likely to develop asthma in homes with gas stoves compared to homes without gas stoves. It's not just asthma -- studies show that replacing gas appliances with electric versions would save hundreds of lives annually in California. We need San Francisco to be a leader on this issue that the rest of the state can follow.

Natural gas combustion in buildings is responsible for a large portion of our city's carbon emissions, which is why we can't afford to delay. Fully electrifying a single house can reduce its carbon emissions by up to 90% depending on how clean the grid is. We are lucky in San Francisco to get most of our energy from carbon-free sources, meaning we get more bang for our buck when we electrify our homes.

While I am in full support of this ordinance, I ask that, to more fully realize the health, climate and economic benefits of electrification and ensure that any exemptions to this important requirement are under legitimately exceptional circumstances, the following changes be made to strengthen the ordinance and implementing regulations:

- 1) eliminate the feasibility exception to the electric-ready requirement;
- 2) create a Clean Energy Buildings Hub that evaluates equity and economic considerations and informs the creation of additional education and technical support resources for affected groups (e.g., small businesses, restaurants, affordable housing, contractors, workforce standards), maximizing opportunities and eliminating barriers to utilization of all-electric new construction to address climate and equity;
- 3) expand and clarify the definition of "Mixed-Fuel Buildings" in the ordinance to include laboratory and industrial buildings, as well as decorative uses of gas;
- 4) provide additional limitations and transparency in the exemption process to ensure any project found exempt for infeasibility is truly in the public interest; and
- 5) eliminate the blanket exemption for commercial kitchens delaying compliance until 2022;

California is burning and our air is unbreathable. There is no more time -- we need bold climate action now. Every building that goes up in San Francisco with gas hookups is just one more building we will have to retrofit for electric heating and appliances later. The prudent thing to do - for our climate, health, and wallets -- is to make sure we aren't digging a deeper hole for ourselves and enact the strongest building electrification ordinance possible. Please support Supervisor Mandelman's ordinance and make San Francisco a climate action leader.

Regards,
nick wolf
201 5th Ave
San Francisco, CA 94118

-- Sent from **Virginia Sturken** to **Supervisor Gordon Mar** on Sep 16, 2020 --

My name is Virginia Sturken, and as your constituent I urge you to support Supervisor Mandelman's proposed ordinance requiring all-electric buildings for new construction. Support for this ordinance is strong in my neighborhood, as we strongly believe that the Board of Supervisors needs to do everything it can to protect public health and reduce carbon emissions. This issue is personal to me because

The health and climate impacts of continued natural gas use are severe. Children are 42% more likely to develop asthma in homes with gas stoves compared to homes without gas stoves. It's not just asthma -- studies show that replacing gas appliances with electric versions would save hundreds of lives annually in California. We need San Francisco to be a leader on this issue that the rest of the state can follow.

Natural gas combustion in buildings is responsible for a large portion of our city's carbon emissions, which is why we can't afford to delay. Fully electrifying a single house can reduce its carbon emissions by up to 90% depending on how clean the grid is. We are lucky in San Francisco to get most of our energy from carbon-free sources, meaning we get more bang for our buck when we electrify our homes.

While I am in full support of this ordinance, I ask that, to more fully realize the health, climate and economic benefits of electrification and ensure that any exemptions to this important requirement are under legitimately exceptional circumstances, the following changes be made to strengthen the ordinance and implementing regulations:

- 1) eliminate the feasibility exception to the electric-ready requirement;
- 2) create a Clean Energy Buildings Hub that evaluates equity and economic considerations and informs the creation of additional education and technical support resources for affected groups (e.g., small businesses, restaurants, affordable housing, contractors, workforce standards), maximizing opportunities and eliminating barriers to utilization of all-electric new construction to address climate and equity;
- 3) expand and clarify the definition of "Mixed-Fuel Buildings" in the ordinance to include laboratory and industrial buildings, as well as decorative uses of gas;
- 4) provide additional limitations and transparency in the exemption process to ensure any project found exempt for infeasibility is truly in the public interest; and
- 5) eliminate the blanket exemption for commercial kitchens delaying compliance until 2022;

California is burning and our air is unbreathable. There is no more time -- we need bold climate action now. Every building that goes up in San Francisco with gas hookups is just one more building we will have to retrofit for electric heating and appliances later. The prudent thing to do - for our climate, health, and wallets -- is to make sure we aren't digging a deeper hole for ourselves and enact the strongest building electrification ordinance possible. Please support Supervisor Mandelman's ordinance and make San Francisco a climate action leader.

Regards,
Virginia Sturken
1930 Vicente St
San Francisco, CA 94116

-- Sent from **Pauline Kahney** to **Supervisor Dean Preston** on Sep 16, 2020 --

My name is Pauline Kahney, and as your constituent I urge you to support Supervisor Mandelman's proposed ordinance requiring all-electric buildings for new construction. Support for this ordinance is strong in my neighborhood, as we strongly believe that the Board of Supervisors needs to do everything it can to protect public health and reduce carbon emissions. This issue is personal to me because

The health and climate impacts of continued natural gas use are severe. Children are 42% more likely to develop asthma in homes with gas stoves compared to homes without gas stoves. It's not just asthma -- studies show that replacing gas appliances with electric versions would save hundreds of lives annually in California. We need San Francisco to be a leader on this issue that the rest of the state can follow.

Natural gas combustion in buildings is responsible for a large portion of our city's carbon emissions, which is why we can't afford to delay. Fully electrifying a single house can reduce its carbon emissions by up to 90% depending on how clean the grid is. We are lucky in San Francisco to get most of our energy from carbon-free sources, meaning we get more bang for our buck when we electrify our homes.

While I am in full support of this ordinance, I ask that, to more fully realize the health, climate and economic benefits of electrification and ensure that any exemptions to this important requirement are under legitimately exceptional circumstances, the following changes be made to strengthen the ordinance and implementing regulations:

- 1) eliminate the feasibility exception to the electric-ready requirement;
- 2) create a Clean Energy Buildings Hub that evaluates equity and economic considerations and informs the creation of additional education and technical support resources for affected groups (e.g., small businesses, restaurants, affordable housing, contractors, workforce standards), maximizing opportunities and eliminating barriers to utilization of all-electric new construction to address climate and equity;
- 3) expand and clarify the definition of "Mixed-Fuel Buildings" in the ordinance to include laboratory and industrial buildings, as well as decorative uses of gas;
- 4) provide additional limitations and transparency in the exemption process to ensure any project found exempt for infeasibility is truly in the public interest; and
- 5) eliminate the blanket exemption for commercial kitchens delaying compliance until 2022;

California is burning and our air is unbreathable. There is no more time -- we need bold climate action now. Every building that goes up in San Francisco with gas hookups is just one more building we will have to retrofit for electric heating and appliances later. The prudent thing to do - for our climate, health, and wallets -- is to make sure we aren't digging a deeper hole for ourselves and enact the strongest building electrification ordinance possible. Please support Supervisor Mandelman's ordinance and make San Francisco a climate action leader.

Regards,
Pauline Kahney
77 Grove St
San Francisco, CA 94102

-- Sent from **Karen Dega** to **Supervisor Sandra Fewer** on Sep 16, 2020 --

My name is Karen Dega, and as your constituent I urge you to support Supervisor Mandelman's proposed ordinance requiring all-electric buildings for new construction. Support for this ordinance is strong in my neighborhood, as we strongly believe that the Board of Supervisors needs to do everything it can to protect public health and reduce carbon emissions. This issue is personal to me because

The health and climate impacts of continued natural gas use are severe. Children are 42% more likely to develop asthma in homes with gas stoves compared to homes without gas stoves. It's not just asthma -- studies show that replacing gas appliances with electric versions would save hundreds of lives annually in California. We need San Francisco to be a leader on this issue that the rest of the state can follow.

Natural gas combustion in buildings is responsible for a large portion of our city's carbon emissions, which is why we can't afford to delay. Fully electrifying a single house can reduce its carbon emissions by up to 90% depending on how clean the grid is. We are lucky in San Francisco to get most of our energy from carbon-free sources, meaning we get more bang for our buck when we electrify our homes.

While I am in full support of this ordinance, I ask that, to more fully realize the health, climate and economic benefits of electrification and ensure that any exemptions to this important requirement are under legitimately exceptional circumstances, the following changes be made to strengthen the ordinance and implementing regulations:

- 1) eliminate the feasibility exception to the electric-ready requirement;
- 2) create a Clean Energy Buildings Hub that evaluates equity and economic considerations and informs the creation of additional education and technical support resources for affected groups (e.g., small businesses, restaurants, affordable housing, contractors, workforce standards), maximizing opportunities and eliminating barriers to utilization of all-electric new construction to address climate and equity;
- 3) expand and clarify the definition of "Mixed-Fuel Buildings" in the ordinance to include laboratory and industrial buildings, as well as decorative uses of gas;
- 4) provide additional limitations and transparency in the exemption process to ensure any project found exempt for infeasibility is truly in the public interest; and
- 5) eliminate the blanket exemption for commercial kitchens delaying compliance until 2022;

California is burning and our air is unbreathable. There is no more time -- we need bold climate action now. Every building that goes up in San Francisco with gas hookups is just one more building we will have to retrofit for electric heating and appliances later. The prudent thing to do - for our climate, health, and wallets -- is to make sure we aren't digging a deeper hole for ourselves and enact the strongest building electrification ordinance possible. Please support Supervisor Mandelman's ordinance and make San Francisco a climate action leader.

Regards,
Karen Dega
738 6th Ave
San Francisco, CA 94118

-- Sent from **Mark Lozano** to **Supervisor Rafael Mandelman** on Sep 16, 2020 --

My name is Mark Lozano, and as your constituent I urge you to support Supervisor Mandelman's proposed ordinance requiring all-electric buildings for new construction. Support for this ordinance is strong in my neighborhood, as we strongly believe that the Board of Supervisors needs to do everything it can to protect public health and reduce carbon emissions. This issue is personal to me because

The health and climate impacts of continued natural gas use are severe. Children are 42% more likely to develop asthma in homes with gas stoves compared to homes without gas stoves. It's not just asthma -- studies show that replacing gas appliances with electric versions would save hundreds of lives annually in California. We need San Francisco to be a leader on this issue that the rest of the state can follow.

Natural gas combustion in buildings is responsible for a large portion of our city's carbon emissions, which is why we can't afford to delay. Fully electrifying a single house can reduce its carbon emissions by up to 90% depending on how clean the grid is. We are lucky in San Francisco to get most of our energy from carbon-free sources, meaning we get more bang for our buck when we electrify our homes.

While I am in full support of this ordinance, I ask that, to more fully realize the health, climate and economic benefits of electrification and ensure that any exemptions to this important requirement are under legitimately exceptional circumstances, the following changes be made to strengthen the ordinance and implementing regulations:

- 1) eliminate the feasibility exception to the electric-ready requirement;
- 2) create a Clean Energy Buildings Hub that evaluates equity and economic considerations and informs the creation of additional education and technical support resources for affected groups (e.g., small businesses, restaurants, affordable housing, contractors, workforce standards), maximizing opportunities and eliminating barriers to utilization of all-electric new construction to address climate and equity;
- 3) expand and clarify the definition of "Mixed-Fuel Buildings" in the ordinance to include laboratory and industrial buildings, as well as decorative uses of gas;
- 4) provide additional limitations and transparency in the exemption process to ensure any project found exempt for infeasibility is truly in the public interest; and
- 5) eliminate the blanket exemption for commercial kitchens delaying compliance until 2022;

California is burning and our air is unbreathable. There is no more time -- we need bold climate action now. Every building that goes up in San Francisco with gas hookups is just one more building we will have to retrofit for electric heating and appliances later. The prudent thing to do - for our climate, health, and wallets -- is to make sure we aren't digging a deeper hole for ourselves and enact the strongest building electrification ordinance possible. Please support Supervisor Mandelman's ordinance and make San Francisco a climate action leader.

Regards,
Mark Lozano
211 30th St
San Francisco, CA 94110

-- Sent from **LaVive Kiely** to **Supervisor Norman Yee** on Sep 16, 2020 --

My name is LaVive Kiely, and as your constituent I urge you to support Supervisor Mandelman's proposed ordinance requiring all-electric buildings for new construction. Support for this ordinance is strong in my neighborhood, as we strongly believe that the Board of Supervisors needs to do everything it can to protect public health and reduce carbon emissions. This issue is personal to me because

The health and climate impacts of continued natural gas use are severe. Children are 42% more likely to develop asthma in homes with gas stoves compared to homes without gas stoves. It's not just asthma -- studies show that replacing gas appliances with electric versions would save hundreds of lives annually in California. We need San Francisco to be a leader on this issue that the rest of the state can follow.

Natural gas combustion in buildings is responsible for a large portion of our city's carbon emissions, which is why we can't afford to delay. Fully electrifying a single house can reduce its carbon emissions by up to 90% depending on how clean the grid is. We are lucky in San Francisco to get most of our energy from carbon-free sources, meaning we get more bang for our buck when we electrify our homes.

While I am in full support of this ordinance, I ask that, to more fully realize the health, climate and economic benefits of electrification and ensure that any exemptions to this important requirement are under legitimately exceptional circumstances, the following changes be made to strengthen the ordinance and implementing regulations:

- 1) eliminate the feasibility exception to the electric-ready requirement;
- 2) create a Clean Energy Buildings Hub that evaluates equity and economic considerations and informs the creation of additional education and technical support resources for affected groups (e.g., small businesses, restaurants, affordable housing, contractors, workforce standards), maximizing opportunities and eliminating barriers to utilization of all-electric new construction to address climate and equity;
- 3) expand and clarify the definition of "Mixed-Fuel Buildings" in the ordinance to include laboratory and industrial buildings, as well as decorative uses of gas;
- 4) provide additional limitations and transparency in the exemption process to ensure any project found exempt for infeasibility is truly in the public interest; and
- 5) eliminate the blanket exemption for commercial kitchens delaying compliance until 2022;

California is burning and our air is unbreathable. There is no more time -- we need bold climate action now. Every building that goes up in San Francisco with gas hookups is just one more building we will have to retrofit for electric heating and appliances later. The prudent thing to do - for our climate, health, and wallets -- is to make sure we aren't digging a deeper hole for ourselves and enact the strongest building electrification ordinance possible. Please support Supervisor Mandelman's ordinance and make San Francisco a climate action leader.

Regards,
LaVive Kiely
1420 Portola Dr
San Francisco, CA 94127

-- Sent from **Mike Kappus** to **Supervisor Matt Haney** on Sep 16, 2020 --

My name is Mike Kappus, and as your constituent I urge you to support Supervisor Mandelman's proposed ordinance requiring all-electric buildings for new construction. Support for this ordinance is strong in my neighborhood, as we strongly believe that the Board of Supervisors needs to do everything it can to protect public health and reduce carbon emissions. This issue is personal to me because

The health and climate impacts of continued natural gas use are severe. Children are 42% more likely to develop asthma in homes with gas stoves compared to homes without gas stoves. It's not just asthma -- studies show that replacing gas appliances with electric versions would save hundreds of lives annually in California. We need San Francisco to be a leader on this issue that the rest of the state can follow.

Natural gas combustion in buildings is responsible for a large portion of our city's carbon emissions, which is why we can't afford to delay. Fully electrifying a single house can reduce its carbon emissions by up to 90% depending on how clean the grid is. We are lucky in San Francisco to get most of our energy from carbon-free sources, meaning we get more bang for our buck when we electrify our homes.

While I am in full support of this ordinance, I ask that, to more fully realize the health, climate and economic benefits of electrification and ensure that any exemptions to this important requirement are under legitimately exceptional circumstances, the following changes be made to strengthen the ordinance and implementing regulations:

- 1) eliminate the feasibility exception to the electric-ready requirement;
- 2) create a Clean Energy Buildings Hub that evaluates equity and economic considerations and informs the creation of additional education and technical support resources for affected groups (e.g., small businesses, restaurants, affordable housing, contractors, workforce standards), maximizing opportunities and eliminating barriers to utilization of all-electric new construction to address climate and equity;
- 3) expand and clarify the definition of "Mixed-Fuel Buildings" in the ordinance to include laboratory and industrial buildings, as well as decorative uses of gas;
- 4) provide additional limitations and transparency in the exemption process to ensure any project found exempt for infeasibility is truly in the public interest; and
- 5) eliminate the blanket exemption for commercial kitchens delaying compliance until 2022;

California is burning and our air is unbreathable. There is no more time -- we need bold climate action now. Every building that goes up in San Francisco with gas hookups is just one more building we will have to retrofit for electric heating and appliances later. The prudent thing to do - for our climate, health, and wallets -- is to make sure we aren't digging a deeper hole for ourselves and enact the strongest building electrification ordinance possible. Please support Supervisor Mandelman's ordinance and make San Francisco a climate action leader.

Regards,
Mike Kappus
650 Delancey St
San Francisco, CA 94107

-- Sent from **Roberto Varea** to **Supervisor Rafael Mandelman** on Sep 16, 2020 --

My name is Roberto Varea, and as your constituent I urge you to support Supervisor Mandelman's proposed ordinance requiring all-electric buildings for new construction. Support for this ordinance is strong in my neighborhood, as we strongly believe that the Board of Supervisors needs to do everything it can to protect public health and reduce carbon emissions. This issue is personal to me because

The health and climate impacts of continued natural gas use are severe. Children are 42% more likely to develop asthma in homes with gas stoves compared to homes without gas stoves. It's not just asthma -- studies show that replacing gas appliances with electric versions would save hundreds of lives annually in California. We need San Francisco to be a leader on this issue that the rest of the state can follow.

Natural gas combustion in buildings is responsible for a large portion of our city's carbon emissions, which is why we can't afford to delay. Fully electrifying a single house can reduce its carbon emissions by up to 90% depending on how clean the grid is. We are lucky in San Francisco to get most of our energy from carbon-free sources, meaning we get more bang for our buck when we electrify our homes.

While I am in full support of this ordinance, I ask that, to more fully realize the health, climate and economic benefits of electrification and ensure that any exemptions to this important requirement are under legitimately exceptional circumstances, the following changes be made to strengthen the ordinance and implementing regulations:

- 1) eliminate the feasibility exception to the electric-ready requirement;
- 2) create a Clean Energy Buildings Hub that evaluates equity and economic considerations and informs the creation of additional education and technical support resources for affected groups (e.g., small businesses, restaurants, affordable housing, contractors, workforce standards), maximizing opportunities and eliminating barriers to utilization of all-electric new construction to address climate and equity;
- 3) expand and clarify the definition of "Mixed-Fuel Buildings" in the ordinance to include laboratory and industrial buildings, as well as decorative uses of gas;
- 4) provide additional limitations and transparency in the exemption process to ensure any project found exempt for infeasibility is truly in the public interest; and
- 5) eliminate the blanket exemption for commercial kitchens delaying compliance until 2022;

California is burning and our air is unbreathable. There is no more time -- we need bold climate action now. Every building that goes up in San Francisco with gas hookups is just one more building we will have to retrofit for electric heating and appliances later. The prudent thing to do - for our climate, health, and wallets -- is to make sure we aren't digging a deeper hole for ourselves and enact the strongest building electrification ordinance possible. Please support Supervisor Mandelman's ordinance and make San Francisco a climate action leader.

Regards,
Roberto Varea
668 29th St
San Francisco, CA 94131

-- Sent from **Maxine Zylberberg** to **Supervisor Rafael Mandelman** on Sep 16, 2020 --

My name is Maxine Zylberberg, and as your constituent I urge you to support Supervisor Mandelman's proposed ordinance requiring all-electric buildings for new construction. Support for this ordinance is strong in my neighborhood, as we strongly believe that the Board of Supervisors needs to do everything it can to protect public health and reduce carbon emissions. This issue is personal to me because

The health and climate impacts of continued natural gas use are severe. Children are 42% more likely to develop asthma in homes with gas stoves compared to homes without gas stoves. It's not just asthma -- studies show that replacing gas appliances with electric versions would save hundreds of lives annually in California. We need San Francisco to be a leader on this issue that the rest of the state can follow.

Natural gas combustion in buildings is responsible for a large portion of our city's carbon emissions, which is why we can't afford to delay. Fully electrifying a single house can reduce its carbon emissions by up to 90% depending on how clean the grid is. We are lucky in San Francisco to get most of our energy from carbon-free sources, meaning we get more bang for our buck when we electrify our homes.

While I am in full support of this ordinance, I ask that, to more fully realize the health, climate and economic benefits of electrification and ensure that any exemptions to this important requirement are under legitimately exceptional circumstances, the following changes be made to strengthen the ordinance and implementing regulations:

- 1) eliminate the feasibility exception to the electric-ready requirement;
- 2) create a Clean Energy Buildings Hub that evaluates equity and economic considerations and informs the creation of additional education and technical support resources for affected groups (e.g., small businesses, restaurants, affordable housing, contractors, workforce standards), maximizing opportunities and eliminating barriers to utilization of all-electric new construction to address climate and equity;
- 3) expand and clarify the definition of "Mixed-Fuel Buildings" in the ordinance to include laboratory and industrial buildings, as well as decorative uses of gas;
- 4) provide additional limitations and transparency in the exemption process to ensure any project found exempt for infeasibility is truly in the public interest; and
- 5) eliminate the blanket exemption for commercial kitchens delaying compliance until 2022;

California is burning and our air is unbreathable. There is no more time -- we need bold climate action now. Every building that goes up in San Francisco with gas hookups is just one more building we will have to retrofit for electric heating and appliances later. The prudent thing to do - for our climate, health, and wallets -- is to make sure we aren't digging a deeper hole for ourselves and enact the strongest building electrification ordinance possible. Please support Supervisor Mandelman's ordinance and make San Francisco a climate action leader.

Regards,
Maxine Zylberberg
32 Dearborn St
San Francisco, CA 94110

-- Sent from **John Steponaitis** to **Supervisor Matt Haney** on Sep 16, 2020 --

My name is John Steponaitis, and as your constituent I urge you to support Supervisor Mandelman's proposed ordinance requiring all-electric buildings for new construction. Support for this ordinance is strong in my neighborhood, as we strongly believe that the Board of Supervisors needs to do everything it can to protect public health and reduce carbon emissions. This issue is personal to me because

The health and climate impacts of continued natural gas use are severe. Children are 42% more likely to develop asthma in homes with gas stoves compared to homes without gas stoves. It's not just asthma -- studies show that replacing gas appliances with electric versions would save hundreds of lives annually in California. We need San Francisco to be a leader on this issue that the rest of the state can follow.

Natural gas combustion in buildings is responsible for a large portion of our city's carbon emissions, which is why we can't afford to delay. Fully electrifying a single house can reduce its carbon emissions by up to 90% depending on how clean the grid is. We are lucky in San Francisco to get most of our energy from carbon-free sources, meaning we get more bang for our buck when we electrify our homes.

While I am in full support of this ordinance, I ask that, to more fully realize the health, climate and economic benefits of electrification and ensure that any exemptions to this important requirement are under legitimately exceptional circumstances, the following changes be made to strengthen the ordinance and implementing regulations:

- 1) eliminate the feasibility exception to the electric-ready requirement;
- 2) create a Clean Energy Buildings Hub that evaluates equity and economic considerations and informs the creation of additional education and technical support resources for affected groups (e.g., small businesses, restaurants, affordable housing, contractors, workforce standards), maximizing opportunities and eliminating barriers to utilization of all-electric new construction to address climate and equity;
- 3) expand and clarify the definition of "Mixed-Fuel Buildings" in the ordinance to include laboratory and industrial buildings, as well as decorative uses of gas;
- 4) provide additional limitations and transparency in the exemption process to ensure any project found exempt for infeasibility is truly in the public interest; and
- 5) eliminate the blanket exemption for commercial kitchens delaying compliance until 2022;

California is burning and our air is unbreathable. There is no more time -- we need bold climate action now. Every building that goes up in San Francisco with gas hookups is just one more building we will have to retrofit for electric heating and appliances later. The prudent thing to do - for our climate, health, and wallets -- is to make sure we aren't digging a deeper hole for ourselves and enact the strongest building electrification ordinance possible. Please support Supervisor Mandelman's ordinance and make San Francisco a climate action leader.

Regards,
John Steponaitis
910 Geary Blvd
San Francisco, CA 94109

-- Sent from **Marsha Seeley** to **Supervisor Dean Preston** on Sep 16, 2020 --

My name is Marsha Seeley, and as your constituent I urge you to support Supervisor Mandelman's proposed ordinance requiring all-electric buildings for new construction. Support for this ordinance is strong in my neighborhood, as we strongly believe that the Board of Supervisors needs to do everything it can to protect public health and reduce carbon emissions. This issue is personal to me because

The health and climate impacts of continued natural gas use are severe. Children are 42% more likely to develop asthma in homes with gas stoves compared to homes without gas stoves. It's not just asthma -- studies show that replacing gas appliances with electric versions would save hundreds of lives annually in California. We need San Francisco to be a leader on this issue that the rest of the state can follow.

Natural gas combustion in buildings is responsible for a large portion of our city's carbon emissions, which is why we can't afford to delay. Fully electrifying a single house can reduce its carbon emissions by up to 90% depending on how clean the grid is. We are lucky in San Francisco to get most of our energy from carbon-free sources, meaning we get more bang for our buck when we electrify our homes.

While I am in full support of this ordinance, I ask that, to more fully realize the health, climate and economic benefits of electrification and ensure that any exemptions to this important requirement are under legitimately exceptional circumstances, the following changes be made to strengthen the ordinance and implementing regulations:

- 1) eliminate the feasibility exception to the electric-ready requirement;
- 2) create a Clean Energy Buildings Hub that evaluates equity and economic considerations and informs the creation of additional education and technical support resources for affected groups (e.g., small businesses, restaurants, affordable housing, contractors, workforce standards), maximizing opportunities and eliminating barriers to utilization of all-electric new construction to address climate and equity;
- 3) expand and clarify the definition of "Mixed-Fuel Buildings" in the ordinance to include laboratory and industrial buildings, as well as decorative uses of gas;
- 4) provide additional limitations and transparency in the exemption process to ensure any project found exempt for infeasibility is truly in the public interest; and
- 5) eliminate the blanket exemption for commercial kitchens delaying compliance until 2022;

California is burning and our air is unbreathable. There is no more time -- we need bold climate action now. Every building that goes up in San Francisco with gas hookups is just one more building we will have to retrofit for electric heating and appliances later. The prudent thing to do - for our climate, health, and wallets -- is to make sure we aren't digging a deeper hole for ourselves and enact the strongest building electrification ordinance possible. Please support Supervisor Mandelman's ordinance and make San Francisco a climate action leader.

Regards,
Marsha Seeley
12-7134 Waioleka St
Pahoa, HI 96778

-- Sent from **Josephine Coffey** to **Supervisor Ahsha Safai** on Sep 16, 2020 --

My name is Josephine Coffey, and as your constituent I urge you to support Supervisor Mandelman's proposed ordinance requiring all-electric buildings for new construction. Support for this ordinance is strong in my neighborhood, as we strongly believe that the Board of Supervisors needs to do everything it can to protect public health and reduce carbon emissions. This issue is personal to me because

The health and climate impacts of continued natural gas use are severe. Children are 42% more likely to develop asthma in homes with gas stoves compared to homes without gas stoves. It's not just asthma -- studies show that replacing gas appliances with electric versions would save hundreds of lives annually in California. We need San Francisco to be a leader on this issue that the rest of the state can follow.

Natural gas combustion in buildings is responsible for a large portion of our city's carbon emissions, which is why we can't afford to delay. Fully electrifying a single house can reduce its carbon emissions by up to 90% depending on how clean the grid is. We are lucky in San Francisco to get most of our energy from carbon-free sources, meaning we get more bang for our buck when we electrify our homes.

While I am in full support of this ordinance, I ask that, to more fully realize the health, climate and economic benefits of electrification and ensure that any exemptions to this important requirement are under legitimately exceptional circumstances, the following changes be made to strengthen the ordinance and implementing regulations:

- 1) eliminate the feasibility exception to the electric-ready requirement;
- 2) create a Clean Energy Buildings Hub that evaluates equity and economic considerations and informs the creation of additional education and technical support resources for affected groups (e.g., small businesses, restaurants, affordable housing, contractors, workforce standards), maximizing opportunities and eliminating barriers to utilization of all-electric new construction to address climate and equity;
- 3) expand and clarify the definition of "Mixed-Fuel Buildings" in the ordinance to include laboratory and industrial buildings, as well as decorative uses of gas;
- 4) provide additional limitations and transparency in the exemption process to ensure any project found exempt for infeasibility is truly in the public interest; and
- 5) eliminate the blanket exemption for commercial kitchens delaying compliance until 2022;

California is burning and our air is unbreathable. There is no more time -- we need bold climate action now. Every building that goes up in San Francisco with gas hookups is just one more building we will have to retrofit for electric heating and appliances later. The prudent thing to do - for our climate, health, and wallets -- is to make sure we aren't digging a deeper hole for ourselves and enact the strongest building electrification ordinance possible. Please support Supervisor Mandelman's ordinance and make San Francisco a climate action leader.

Regards,
Josephine Coffey
248 Dublin St
San Francisco, CA 94112

-- Sent from **Kathleen Weckenman** to **Supervisor Ahsha Safai** on Sep 16, 2020 --

My name is Kathleen Weckenman, and as your constituent I urge you to support Supervisor Mandelman's proposed ordinance requiring all-electric buildings for new construction. Support for this ordinance is strong in my neighborhood, as we strongly believe that the Board of Supervisors needs to do everything it can to protect public health and reduce carbon emissions. This issue is personal to me because

The health and climate impacts of continued natural gas use are severe. Children are 42% more likely to develop asthma in homes with gas stoves compared to homes without gas stoves. It's not just asthma -- studies show that replacing gas appliances with electric versions would save hundreds of lives annually in California. We need San Francisco to be a leader on this issue that the rest of the state can follow.

Natural gas combustion in buildings is responsible for a large portion of our city's carbon emissions, which is why we can't afford to delay. Fully electrifying a single house can reduce its carbon emissions by up to 90% depending on how clean the grid is. We are lucky in San Francisco to get most of our energy from carbon-free sources, meaning we get more bang for our buck when we electrify our homes.

While I am in full support of this ordinance, I ask that, to more fully realize the health, climate and economic benefits of electrification and ensure that any exemptions to this important requirement are under legitimately exceptional circumstances, the following changes be made to strengthen the ordinance and implementing regulations:

- 1) eliminate the feasibility exception to the electric-ready requirement;
- 2) create a Clean Energy Buildings Hub that evaluates equity and economic considerations and informs the creation of additional education and technical support resources for affected groups (e.g., small businesses, restaurants, affordable housing, contractors, workforce standards), maximizing opportunities and eliminating barriers to utilization of all-electric new construction to address climate and equity;
- 3) expand and clarify the definition of "Mixed-Fuel Buildings" in the ordinance to include laboratory and industrial buildings, as well as decorative uses of gas;
- 4) provide additional limitations and transparency in the exemption process to ensure any project found exempt for infeasibility is truly in the public interest; and
- 5) eliminate the blanket exemption for commercial kitchens delaying compliance until 2022;

California is burning and our air is unbreathable. There is no more time -- we need bold climate action now. Every building that goes up in San Francisco with gas hookups is just one more building we will have to retrofit for electric heating and appliances later. The prudent thing to do - for our climate, health, and wallets -- is to make sure we aren't digging a deeper hole for ourselves and enact the strongest building electrification ordinance possible. Please support Supervisor Mandelman's ordinance and make San Francisco a climate action leader.

Regards,
Kathleen Weckenman
89 Ina Ct
San Francisco, CA 94112

-- Sent from **Katherine Roberts** to **Supervisor Dean Preston** on Sep 16, 2020 --

My name is Katherine Roberts, and as your constituent I urge you to support Supervisor Mandelman's proposed ordinance requiring all-electric buildings for new construction. Support for this ordinance is strong in my neighborhood, as we strongly believe that the Board of Supervisors needs to do everything it can to protect public health and reduce carbon emissions. This issue is personal to me because

The health and climate impacts of continued natural gas use are severe. Children are 42% more likely to develop asthma in homes with gas stoves compared to homes without gas stoves. It's not just asthma -- studies show that replacing gas appliances with electric versions would save hundreds of lives annually in California. We need San Francisco to be a leader on this issue that the rest of the state can follow.

Natural gas combustion in buildings is responsible for a large portion of our city's carbon emissions, which is why we can't afford to delay. Fully electrifying a single house can reduce its carbon emissions by up to 90% depending on how clean the grid is. We are lucky in San Francisco to get most of our energy from carbon-free sources, meaning we get more bang for our buck when we electrify our homes.

While I am in full support of this ordinance, I ask that, to more fully realize the health, climate and economic benefits of electrification and ensure that any exemptions to this important requirement are under legitimately exceptional circumstances, the following changes be made to strengthen the ordinance and implementing regulations:

- 1) eliminate the feasibility exception to the electric-ready requirement;
- 2) create a Clean Energy Buildings Hub that evaluates equity and economic considerations and informs the creation of additional education and technical support resources for affected groups (e.g., small businesses, restaurants, affordable housing, contractors, workforce standards), maximizing opportunities and eliminating barriers to utilization of all-electric new construction to address climate and equity;
- 3) expand and clarify the definition of "Mixed-Fuel Buildings" in the ordinance to include laboratory and industrial buildings, as well as decorative uses of gas;
- 4) provide additional limitations and transparency in the exemption process to ensure any project found exempt for infeasibility is truly in the public interest; and
- 5) eliminate the blanket exemption for commercial kitchens delaying compliance until 2022;

California is burning and our air is unbreathable. There is no more time -- we need bold climate action now. Every building that goes up in San Francisco with gas hookups is just one more building we will have to retrofit for electric heating and appliances later. The prudent thing to do - for our climate, health, and wallets -- is to make sure we aren't digging a deeper hole for ourselves and enact the strongest building electrification ordinance possible. Please support Supervisor Mandelman's ordinance and make San Francisco a climate action leader.

Regards,
Katherine Roberts
199 Beulah St
San Francisco, CA 94117

-- Sent from **Susan Mehrings** to **Supervisor Dean Preston** on Sep 16, 2020 --

My name is Susan Mehrings, and as your constituent I urge you to support Supervisor Mandelman's proposed ordinance requiring all-electric buildings for new construction. Support for this ordinance is strong in my neighborhood, as we strongly believe that the Board of Supervisors needs to do everything it can to protect public health and reduce carbon emissions. This issue is personal to me because

The health and climate impacts of continued natural gas use are severe. Children are 42% more likely to develop asthma in homes with gas stoves compared to homes without gas stoves. It's not just asthma -- studies show that replacing gas appliances with electric versions would save hundreds of lives annually in California. We need San Francisco to be a leader on this issue that the rest of the state can follow.

Natural gas combustion in buildings is responsible for a large portion of our city's carbon emissions, which is why we can't afford to delay. Fully electrifying a single house can reduce its carbon emissions by up to 90% depending on how clean the grid is. We are lucky in San Francisco to get most of our energy from carbon-free sources, meaning we get more bang for our buck when we electrify our homes.

While I am in full support of this ordinance, I ask that, to more fully realize the health, climate and economic benefits of electrification and ensure that any exemptions to this important requirement are under legitimately exceptional circumstances, the following changes be made to strengthen the ordinance and implementing regulations:

- 1) eliminate the feasibility exception to the electric-ready requirement;
- 2) create a Clean Energy Buildings Hub that evaluates equity and economic considerations and informs the creation of additional education and technical support resources for affected groups (e.g., small businesses, restaurants, affordable housing, contractors, workforce standards), maximizing opportunities and eliminating barriers to utilization of all-electric new construction to address climate and equity;
- 3) expand and clarify the definition of "Mixed-Fuel Buildings" in the ordinance to include laboratory and industrial buildings, as well as decorative uses of gas;
- 4) provide additional limitations and transparency in the exemption process to ensure any project found exempt for infeasibility is truly in the public interest; and
- 5) eliminate the blanket exemption for commercial kitchens delaying compliance until 2022;

California is burning and our air is unbreathable. There is no more time -- we need bold climate action now. Every building that goes up in San Francisco with gas hookups is just one more building we will have to retrofit for electric heating and appliances later. The prudent thing to do - for our climate, health, and wallets -- is to make sure we aren't digging a deeper hole for ourselves and enact the strongest building electrification ordinance possible. Please support Supervisor Mandelman's ordinance and make San Francisco a climate action leader.

Regards,
Susan Mehrings
1240 Hayes St
San Francisco, CA 94117

-- Sent from **Lisa Kellman** to **Supervisor Rafael Mandelman** on Sep 16, 2020 --

My name is Lisa Kellman, and as your constituent I urge you to support Supervisor Mandelman's proposed ordinance requiring all-electric buildings for new construction. Support for this ordinance is strong in my neighborhood, as we strongly believe that the Board of Supervisors needs to do everything it can to protect public health and reduce carbon emissions. This issue is personal to me because

The health and climate impacts of continued natural gas use are severe. Children are 42% more likely to develop asthma in homes with gas stoves compared to homes without gas stoves. It's not just asthma -- studies show that replacing gas appliances with electric versions would save hundreds of lives annually in California. We need San Francisco to be a leader on this issue that the rest of the state can follow.

Natural gas combustion in buildings is responsible for a large portion of our city's carbon emissions, which is why we can't afford to delay. Fully electrifying a single house can reduce its carbon emissions by up to 90% depending on how clean the grid is. We are lucky in San Francisco to get most of our energy from carbon-free sources, meaning we get more bang for our buck when we electrify our homes.

While I am in full support of this ordinance, I ask that, to more fully realize the health, climate and economic benefits of electrification and ensure that any exemptions to this important requirement are under legitimately exceptional circumstances, the following changes be made to strengthen the ordinance and implementing regulations:

- 1) eliminate the feasibility exception to the electric-ready requirement;
- 2) create a Clean Energy Buildings Hub that evaluates equity and economic considerations and informs the creation of additional education and technical support resources for affected groups (e.g., small businesses, restaurants, affordable housing, contractors, workforce standards), maximizing opportunities and eliminating barriers to utilization of all-electric new construction to address climate and equity;
- 3) expand and clarify the definition of "Mixed-Fuel Buildings" in the ordinance to include laboratory and industrial buildings, as well as decorative uses of gas;
- 4) provide additional limitations and transparency in the exemption process to ensure any project found exempt for infeasibility is truly in the public interest; and
- 5) eliminate the blanket exemption for commercial kitchens delaying compliance until 2022;

California is burning and our air is unbreathable. There is no more time -- we need bold climate action now. Every building that goes up in San Francisco with gas hookups is just one more building we will have to retrofit for electric heating and appliances later. The prudent thing to do - for our climate, health, and wallets -- is to make sure we aren't digging a deeper hole for ourselves and enact the strongest building electrification ordinance possible. Please support Supervisor Mandelman's ordinance and make San Francisco a climate action leader.

Regards,
Lisa Kellman
474 Day St
San Francisco, CA 94131

-- Sent from **Jc Sarmiento** to **Supervisor Hillary Ronen** on Sep 16, 2020 --

My name is Jc Sarmiento, and as your constituent I urge you to support Supervisor Mandelman's proposed ordinance requiring all-electric buildings for new construction. Support for this ordinance is strong in my neighborhood, as we strongly believe that the Board of Supervisors needs to do everything it can to protect public health and reduce carbon emissions. This issue is personal to me because

The health and climate impacts of continued natural gas use are severe. Children are 42% more likely to develop asthma in homes with gas stoves compared to homes without gas stoves. It's not just asthma -- studies show that replacing gas appliances with electric versions would save hundreds of lives annually in California. We need San Francisco to be a leader on this issue that the rest of the state can follow.

Natural gas combustion in buildings is responsible for a large portion of our city's carbon emissions, which is why we can't afford to delay. Fully electrifying a single house can reduce its carbon emissions by up to 90% depending on how clean the grid is. We are lucky in San Francisco to get most of our energy from carbon-free sources, meaning we get more bang for our buck when we electrify our homes.

While I am in full support of this ordinance, I ask that, to more fully realize the health, climate and economic benefits of electrification and ensure that any exemptions to this important requirement are under legitimately exceptional circumstances, the following changes be made to strengthen the ordinance and implementing regulations:

- 1) eliminate the feasibility exception to the electric-ready requirement;
- 2) create a Clean Energy Buildings Hub that evaluates equity and economic considerations and informs the creation of additional education and technical support resources for affected groups (e.g., small businesses, restaurants, affordable housing, contractors, workforce standards), maximizing opportunities and eliminating barriers to utilization of all-electric new construction to address climate and equity;
- 3) expand and clarify the definition of "Mixed-Fuel Buildings" in the ordinance to include laboratory and industrial buildings, as well as decorative uses of gas;
- 4) provide additional limitations and transparency in the exemption process to ensure any project found exempt for infeasibility is truly in the public interest; and
- 5) eliminate the blanket exemption for commercial kitchens delaying compliance until 2022;

California is burning and our air is unbreathable. There is no more time -- we need bold climate action now. Every building that goes up in San Francisco with gas hookups is just one more building we will have to retrofit for electric heating and appliances later. The prudent thing to do - for our climate, health, and wallets -- is to make sure we aren't digging a deeper hole for ourselves and enact the strongest building electrification ordinance possible. Please support Supervisor Mandelman's ordinance and make San Francisco a climate action leader.

Regards,
Jc Sarmiento
109 Bartlett St
San Francisco, CA 94110

-- Sent from **Dana Landis** to **Supervisor Rafael Mandelman** on Sep 16, 2020 --

My name is Dana Landis, and as your constituent I urge you to support Supervisor Mandelman's proposed ordinance requiring all-electric buildings for new construction. Support for this ordinance is strong in my neighborhood, as we strongly believe that the Board of Supervisors needs to do everything it can to protect public health and reduce carbon emissions. This issue is personal to me because

The health and climate impacts of continued natural gas use are severe. Children are 42% more likely to develop asthma in homes with gas stoves compared to homes without gas stoves. It's not just asthma -- studies show that replacing gas appliances with electric versions would save hundreds of lives annually in California. We need San Francisco to be a leader on this issue that the rest of the state can follow.

Natural gas combustion in buildings is responsible for a large portion of our city's carbon emissions, which is why we can't afford to delay. Fully electrifying a single house can reduce its carbon emissions by up to 90% depending on how clean the grid is. We are lucky in San Francisco to get most of our energy from carbon-free sources, meaning we get more bang for our buck when we electrify our homes.

While I am in full support of this ordinance, I ask that, to more fully realize the health, climate and economic benefits of electrification and ensure that any exemptions to this important requirement are under legitimately exceptional circumstances, the following changes be made to strengthen the ordinance and implementing regulations:

- 1) eliminate the feasibility exception to the electric-ready requirement;
- 2) create a Clean Energy Buildings Hub that evaluates equity and economic considerations and informs the creation of additional education and technical support resources for affected groups (e.g., small businesses, restaurants, affordable housing, contractors, workforce standards), maximizing opportunities and eliminating barriers to utilization of all-electric new construction to address climate and equity;
- 3) expand and clarify the definition of "Mixed-Fuel Buildings" in the ordinance to include laboratory and industrial buildings, as well as decorative uses of gas;
- 4) provide additional limitations and transparency in the exemption process to ensure any project found exempt for infeasibility is truly in the public interest; and
- 5) eliminate the blanket exemption for commercial kitchens delaying compliance until 2022;

California is burning and our air is unbreathable. There is no more time -- we need bold climate action now. Every building that goes up in San Francisco with gas hookups is just one more building we will have to retrofit for electric heating and appliances later. The prudent thing to do - for our climate, health, and wallets -- is to make sure we aren't digging a deeper hole for ourselves and enact the strongest building electrification ordinance possible. Please support Supervisor Mandelman's ordinance and make San Francisco a climate action leader.

Regards,
Dana Landis
401 30th St
San Francisco, CA 94131

-- Sent from **NATASHA Hopkinson** to **Supervisor Sandra Fewer** on Sep 16, 2020 --

My name is NATASHA Hopkinson, and as your constituent I urge you to support Supervisor Mandelman's proposed ordinance requiring all-electric buildings for new construction. Support for this ordinance is strong in my neighborhood, as we strongly believe that the Board of Supervisors needs to do everything it can to protect public health and reduce carbon emissions. This issue is personal to me because

The health and climate impacts of continued natural gas use are severe. Children are 42% more likely to develop asthma in homes with gas stoves compared to homes without gas stoves. It's not just asthma -- studies show that replacing gas appliances with electric versions would save hundreds of lives annually in California. We need San Francisco to be a leader on this issue that the rest of the state can follow.

Natural gas combustion in buildings is responsible for a large portion of our city's carbon emissions, which is why we can't afford to delay. Fully electrifying a single house can reduce its carbon emissions by up to 90% depending on how clean the grid is. We are lucky in San Francisco to get most of our energy from carbon-free sources, meaning we get more bang for our buck when we electrify our homes.

While I am in full support of this ordinance, I ask that, to more fully realize the health, climate and economic benefits of electrification and ensure that any exemptions to this important requirement are under legitimately exceptional circumstances, the following changes be made to strengthen the ordinance and implementing regulations:

- 1) eliminate the feasibility exception to the electric-ready requirement;
- 2) create a Clean Energy Buildings Hub that evaluates equity and economic considerations and informs the creation of additional education and technical support resources for affected groups (e.g., small businesses, restaurants, affordable housing, contractors, workforce standards), maximizing opportunities and eliminating barriers to utilization of all-electric new construction to address climate and equity;
- 3) expand and clarify the definition of "Mixed-Fuel Buildings" in the ordinance to include laboratory and industrial buildings, as well as decorative uses of gas;
- 4) provide additional limitations and transparency in the exemption process to ensure any project found exempt for infeasibility is truly in the public interest; and
- 5) eliminate the blanket exemption for commercial kitchens delaying compliance until 2022;

California is burning and our air is unbreathable. There is no more time -- we need bold climate action now. Every building that goes up in San Francisco with gas hookups is just one more building we will have to retrofit for electric heating and appliances later. The prudent thing to do - for our climate, health, and wallets -- is to make sure we aren't digging a deeper hole for ourselves and enact the strongest building electrification ordinance possible. Please support Supervisor Mandelman's ordinance and make San Francisco a climate action leader.

Regards,
NATASHA Hopkinson
542 29th Ave
San Francisco, CA 94121

-- Sent from **Linda Bellavia** to **Supervisor Catherine Stefani** on Sep 16, 2020 --

My name is Linda Bellavia, and as your constituent I urge you to support Supervisor Mandelman's proposed ordinance requiring all-electric buildings for new construction. Support for this ordinance is strong in my neighborhood, as we strongly believe that the Board of Supervisors needs to do everything it can to protect public health and reduce carbon emissions. This issue is personal to me because

The health and climate impacts of continued natural gas use are severe. Children are 42% more likely to develop asthma in homes with gas stoves compared to homes without gas stoves. It's not just asthma -- studies show that replacing gas appliances with electric versions would save hundreds of lives annually in California. We need San Francisco to be a leader on this issue that the rest of the state can follow.

Natural gas combustion in buildings is responsible for a large portion of our city's carbon emissions, which is why we can't afford to delay. Fully electrifying a single house can reduce its carbon emissions by up to 90% depending on how clean the grid is. We are lucky in San Francisco to get most of our energy from carbon-free sources, meaning we get more bang for our buck when we electrify our homes.

While I am in full support of this ordinance, I ask that, to more fully realize the health, climate and economic benefits of electrification and ensure that any exemptions to this important requirement are under legitimately exceptional circumstances, the following changes be made to strengthen the ordinance and implementing regulations:

- 1) eliminate the feasibility exception to the electric-ready requirement;
- 2) create a Clean Energy Buildings Hub that evaluates equity and economic considerations and informs the creation of additional education and technical support resources for affected groups (e.g., small businesses, restaurants, affordable housing, contractors, workforce standards), maximizing opportunities and eliminating barriers to utilization of all-electric new construction to address climate and equity;
- 3) expand and clarify the definition of "Mixed-Fuel Buildings" in the ordinance to include laboratory and industrial buildings, as well as decorative uses of gas;
- 4) provide additional limitations and transparency in the exemption process to ensure any project found exempt for infeasibility is truly in the public interest; and
- 5) eliminate the blanket exemption for commercial kitchens delaying compliance until 2022;

California is burning and our air is unbreathable. There is no more time -- we need bold climate action now. Every building that goes up in San Francisco with gas hookups is just one more building we will have to retrofit for electric heating and appliances later. The prudent thing to do - for our climate, health, and wallets -- is to make sure we aren't digging a deeper hole for ourselves and enact the strongest building electrification ordinance possible. Please support Supervisor Mandelman's ordinance and make San Francisco a climate action leader.

Regards,
Linda Bellavia
2698 California St
San Francisco, CA 94115

-- Sent from **Christopher Aycock** to **Supervisor Gordon Mar** on Sep 16, 2020 --

My name is Christopher Aycock, and as your constituent I urge you to support Supervisor Mandelman's proposed ordinance requiring all-electric buildings for new construction. Support for this ordinance is strong in my neighborhood, as we strongly believe that the Board of Supervisors needs to do everything it can to protect public health and reduce carbon emissions. This issue is personal to me because

The health and climate impacts of continued natural gas use are severe. Children are 42% more likely to develop asthma in homes with gas stoves compared to homes without gas stoves. It's not just asthma -- studies show that replacing gas appliances with electric versions would save hundreds of lives annually in California. We need San Francisco to be a leader on this issue that the rest of the state can follow.

Natural gas combustion in buildings is responsible for a large portion of our city's carbon emissions, which is why we can't afford to delay. Fully electrifying a single house can reduce its carbon emissions by up to 90% depending on how clean the grid is. We are lucky in San Francisco to get most of our energy from carbon-free sources, meaning we get more bang for our buck when we electrify our homes.

While I am in full support of this ordinance, I ask that, to more fully realize the health, climate and economic benefits of electrification and ensure that any exemptions to this important requirement are under legitimately exceptional circumstances, the following changes be made to strengthen the ordinance and implementing regulations:

- 1) eliminate the feasibility exception to the electric-ready requirement;
- 2) create a Clean Energy Buildings Hub that evaluates equity and economic considerations and informs the creation of additional education and technical support resources for affected groups (e.g., small businesses, restaurants, affordable housing, contractors, workforce standards), maximizing opportunities and eliminating barriers to utilization of all-electric new construction to address climate and equity;
- 3) expand and clarify the definition of "Mixed-Fuel Buildings" in the ordinance to include laboratory and industrial buildings, as well as decorative uses of gas;
- 4) provide additional limitations and transparency in the exemption process to ensure any project found exempt for infeasibility is truly in the public interest; and
- 5) eliminate the blanket exemption for commercial kitchens delaying compliance until 2022;

California is burning and our air is unbreathable. There is no more time -- we need bold climate action now. Every building that goes up in San Francisco with gas hookups is just one more building we will have to retrofit for electric heating and appliances later. The prudent thing to do - for our climate, health, and wallets -- is to make sure we aren't digging a deeper hole for ourselves and enact the strongest building electrification ordinance possible. Please support Supervisor Mandelman's ordinance and make San Francisco a climate action leader.

Regards,
Christopher Aycock
2663 24th Ave
San Francisco, CA 94116

-- Sent from **Martha Larsen** to **Supervisor Sandra Fewer** on Sep 16, 2020 --

My name is Martha Larsen, and as your constituent I urge you to support Supervisor Mandelman's proposed ordinance requiring all-electric buildings for new construction. Support for this ordinance is strong in my neighborhood, as we strongly believe that the Board of Supervisors needs to do everything it can to protect public health and reduce carbon emissions. This issue is personal to me because

The health and climate impacts of continued natural gas use are severe. Children are 42% more likely to develop asthma in homes with gas stoves compared to homes without gas stoves. It's not just asthma -- studies show that replacing gas appliances with electric versions would save hundreds of lives annually in California. We need San Francisco to be a leader on this issue that the rest of the state can follow.

Natural gas combustion in buildings is responsible for a large portion of our city's carbon emissions, which is why we can't afford to delay. Fully electrifying a single house can reduce its carbon emissions by up to 90% depending on how clean the grid is. We are lucky in San Francisco to get most of our energy from carbon-free sources, meaning we get more bang for our buck when we electrify our homes.

While I am in full support of this ordinance, I ask that, to more fully realize the health, climate and economic benefits of electrification and ensure that any exemptions to this important requirement are under legitimately exceptional circumstances, the following changes be made to strengthen the ordinance and implementing regulations:

- 1) eliminate the feasibility exception to the electric-ready requirement;
- 2) create a Clean Energy Buildings Hub that evaluates equity and economic considerations and informs the creation of additional education and technical support resources for affected groups (e.g., small businesses, restaurants, affordable housing, contractors, workforce standards), maximizing opportunities and eliminating barriers to utilization of all-electric new construction to address climate and equity;
- 3) expand and clarify the definition of "Mixed-Fuel Buildings" in the ordinance to include laboratory and industrial buildings, as well as decorative uses of gas;
- 4) provide additional limitations and transparency in the exemption process to ensure any project found exempt for infeasibility is truly in the public interest; and
- 5) eliminate the blanket exemption for commercial kitchens delaying compliance until 2022;

California is burning and our air is unbreathable. There is no more time -- we need bold climate action now. Every building that goes up in San Francisco with gas hookups is just one more building we will have to retrofit for electric heating and appliances later. The prudent thing to do - for our climate, health, and wallets -- is to make sure we aren't digging a deeper hole for ourselves and enact the strongest building electrification ordinance possible. Please support Supervisor Mandelman's ordinance and make San Francisco a climate action leader.

Regards,
Martha Larsen
828 30th Ave
San Francisco, CA 94121

-- Sent from **Janny Hazelaar** to **Supervisor Rafael Mandelman** on Sep 16, 2020 --

My name is Janny Hazelaar, and as your constituent I urge you to support Supervisor Mandelman's proposed ordinance requiring all-electric buildings for new construction. Support for this ordinance is strong in my neighborhood, as we strongly believe that the Board of Supervisors needs to do everything it can to protect public health and reduce carbon emissions. This issue is personal to me because

The health and climate impacts of continued natural gas use are severe. Children are 42% more likely to develop asthma in homes with gas stoves compared to homes without gas stoves. It's not just asthma -- studies show that replacing gas appliances with electric versions would save hundreds of lives annually in California. We need San Francisco to be a leader on this issue that the rest of the state can follow.

Natural gas combustion in buildings is responsible for a large portion of our city's carbon emissions, which is why we can't afford to delay. Fully electrifying a single house can reduce its carbon emissions by up to 90% depending on how clean the grid is. We are lucky in San Francisco to get most of our energy from carbon-free sources, meaning we get more bang for our buck when we electrify our homes.

While I am in full support of this ordinance, I ask that, to more fully realize the health, climate and economic benefits of electrification and ensure that any exemptions to this important requirement are under legitimately exceptional circumstances, the following changes be made to strengthen the ordinance and implementing regulations:

- 1) eliminate the feasibility exception to the electric-ready requirement;
- 2) create a Clean Energy Buildings Hub that evaluates equity and economic considerations and informs the creation of additional education and technical support resources for affected groups (e.g., small businesses, restaurants, affordable housing, contractors, workforce standards), maximizing opportunities and eliminating barriers to utilization of all-electric new construction to address climate and equity;
- 3) expand and clarify the definition of "Mixed-Fuel Buildings" in the ordinance to include laboratory and industrial buildings, as well as decorative uses of gas;
- 4) provide additional limitations and transparency in the exemption process to ensure any project found exempt for infeasibility is truly in the public interest; and
- 5) eliminate the blanket exemption for commercial kitchens delaying compliance until 2022;

California is burning and our air is unbreathable. There is no more time -- we need bold climate action now. Every building that goes up in San Francisco with gas hookups is just one more building we will have to retrofit for electric heating and appliances later. The prudent thing to do - for our climate, health, and wallets -- is to make sure we aren't digging a deeper hole for ourselves and enact the strongest building electrification ordinance possible. Please support Supervisor Mandelman's ordinance and make San Francisco a climate action leader.

Regards,
Janny Hazelaar
1040 Ashbury St
San Francisco, CA 94117

-- Sent from **David Gemigniani** to **Supervisor Gordon Mar** on Sep 16, 2020 --

My name is David Gemigniani, and as your constituent I urge you to support Supervisor Mandelman's proposed ordinance requiring all-electric buildings for new construction. Support for this ordinance is strong in my neighborhood, as we strongly believe that the Board of Supervisors needs to do everything it can to protect public health and reduce carbon emissions. This issue is personal to me because

The health and climate impacts of continued natural gas use are severe. Children are 42% more likely to develop asthma in homes with gas stoves compared to homes without gas stoves. It's not just asthma -- studies show that replacing gas appliances with electric versions would save hundreds of lives annually in California. We need San Francisco to be a leader on this issue that the rest of the state can follow.

Natural gas combustion in buildings is responsible for a large portion of our city's carbon emissions, which is why we can't afford to delay. Fully electrifying a single house can reduce its carbon emissions by up to 90% depending on how clean the grid is. We are lucky in San Francisco to get most of our energy from carbon-free sources, meaning we get more bang for our buck when we electrify our homes.

While I am in full support of this ordinance, I ask that, to more fully realize the health, climate and economic benefits of electrification and ensure that any exemptions to this important requirement are under legitimately exceptional circumstances, the following changes be made to strengthen the ordinance and implementing regulations:

- 1) eliminate the feasibility exception to the electric-ready requirement;
- 2) create a Clean Energy Buildings Hub that evaluates equity and economic considerations and informs the creation of additional education and technical support resources for affected groups (e.g., small businesses, restaurants, affordable housing, contractors, workforce standards), maximizing opportunities and eliminating barriers to utilization of all-electric new construction to address climate and equity;
- 3) expand and clarify the definition of "Mixed-Fuel Buildings" in the ordinance to include laboratory and industrial buildings, as well as decorative uses of gas;
- 4) provide additional limitations and transparency in the exemption process to ensure any project found exempt for infeasibility is truly in the public interest; and
- 5) eliminate the blanket exemption for commercial kitchens delaying compliance until 2022;

California is burning and our air is unbreathable. There is no more time -- we need bold climate action now. Every building that goes up in San Francisco with gas hookups is just one more building we will have to retrofit for electric heating and appliances later. The prudent thing to do - for our climate, health, and wallets -- is to make sure we aren't digging a deeper hole for ourselves and enact the strongest building electrification ordinance possible. Please support Supervisor Mandelman's ordinance and make San Francisco a climate action leader.

Regards,
David Gemigniani
1285 44th Ave
San Francisco, CA 94122

-- Sent from **Michael Lamperd** to **Supervisor Gordon Mar** on Sep 16, 2020 --

My name is Michael Lamperd, and as your constituent I urge you to support Supervisor Mandelman's proposed ordinance requiring all-electric buildings for new construction. Support for this ordinance is strong in my neighborhood, as we strongly believe that the Board of Supervisors needs to do everything it can to protect public health and reduce carbon emissions. This issue is personal to me because

The health and climate impacts of continued natural gas use are severe. Children are 42% more likely to develop asthma in homes with gas stoves compared to homes without gas stoves. It's not just asthma -- studies show that replacing gas appliances with electric versions would save hundreds of lives annually in California. We need San Francisco to be a leader on this issue that the rest of the state can follow.

Natural gas combustion in buildings is responsible for a large portion of our city's carbon emissions, which is why we can't afford to delay. Fully electrifying a single house can reduce its carbon emissions by up to 90% depending on how clean the grid is. We are lucky in San Francisco to get most of our energy from carbon-free sources, meaning we get more bang for our buck when we electrify our homes.

While I am in full support of this ordinance, I ask that, to more fully realize the health, climate and economic benefits of electrification and ensure that any exemptions to this important requirement are under legitimately exceptional circumstances, the following changes be made to strengthen the ordinance and implementing regulations:

- 1) eliminate the feasibility exception to the electric-ready requirement;
- 2) create a Clean Energy Buildings Hub that evaluates equity and economic considerations and informs the creation of additional education and technical support resources for affected groups (e.g., small businesses, restaurants, affordable housing, contractors, workforce standards), maximizing opportunities and eliminating barriers to utilization of all-electric new construction to address climate and equity;
- 3) expand and clarify the definition of "Mixed-Fuel Buildings" in the ordinance to include laboratory and industrial buildings, as well as decorative uses of gas;
- 4) provide additional limitations and transparency in the exemption process to ensure any project found exempt for infeasibility is truly in the public interest; and
- 5) eliminate the blanket exemption for commercial kitchens delaying compliance until 2022;

California is burning and our air is unbreathable. There is no more time -- we need bold climate action now. Every building that goes up in San Francisco with gas hookups is just one more building we will have to retrofit for electric heating and appliances later. The prudent thing to do - for our climate, health, and wallets -- is to make sure we aren't digging a deeper hole for ourselves and enact the strongest building electrification ordinance possible. Please support Supervisor Mandelman's ordinance and make San Francisco a climate action leader.

Regards,
Michael Lamperd
4611 Lincoln Way
San Francisco, CA 94122

-- Sent from **Ellen Koivisto** to **Supervisor Gordon Mar** on Sep 16, 2020 --

My name is Ellen Koivisto, and as your constituent I urge you to support Supervisor Mandelman's proposed ordinance requiring all-electric buildings for new construction. Support for this ordinance is strong in my neighborhood, as we strongly believe that the Board of Supervisors needs to do everything it can to protect public health and reduce carbon emissions. This issue is personal to me because

The health and climate impacts of continued natural gas use are severe. Children are 42% more likely to develop asthma in homes with gas stoves compared to homes without gas stoves. It's not just asthma -- studies show that replacing gas appliances with electric versions would save hundreds of lives annually in California. We need San Francisco to be a leader on this issue that the rest of the state can follow.

Natural gas combustion in buildings is responsible for a large portion of our city's carbon emissions, which is why we can't afford to delay. Fully electrifying a single house can reduce its carbon emissions by up to 90% depending on how clean the grid is. We are lucky in San Francisco to get most of our energy from carbon-free sources, meaning we get more bang for our buck when we electrify our homes.

While I am in full support of this ordinance, I ask that, to more fully realize the health, climate and economic benefits of electrification and ensure that any exemptions to this important requirement are under legitimately exceptional circumstances, the following changes be made to strengthen the ordinance and implementing regulations:

- 1) eliminate the feasibility exception to the electric-ready requirement;
- 2) create a Clean Energy Buildings Hub that evaluates equity and economic considerations and informs the creation of additional education and technical support resources for affected groups (e.g., small businesses, restaurants, affordable housing, contractors, workforce standards), maximizing opportunities and eliminating barriers to utilization of all-electric new construction to address climate and equity;
- 3) expand and clarify the definition of "Mixed-Fuel Buildings" in the ordinance to include laboratory and industrial buildings, as well as decorative uses of gas;
- 4) provide additional limitations and transparency in the exemption process to ensure any project found exempt for infeasibility is truly in the public interest; and
- 5) eliminate the blanket exemption for commercial kitchens delaying compliance until 2022;

California is burning and our air is unbreathable. There is no more time -- we need bold climate action now. Every building that goes up in San Francisco with gas hookups is just one more building we will have to retrofit for electric heating and appliances later. The prudent thing to do - for our climate, health, and wallets -- is to make sure we aren't digging a deeper hole for ourselves and enact the strongest building electrification ordinance possible. Please support Supervisor Mandelman's ordinance and make San Francisco a climate action leader.

Regards,
Ellen Koivisto
1556 Great Hwy
San Francisco, CA 94122

-- Sent from **Josh Brockmann** to **Supervisor Dean Preston** on Sep 16, 2020 --

My name is Josh Brockmann, and as your constituent I urge you to support Supervisor Mandelman's proposed ordinance requiring all-electric buildings for new construction. Support for this ordinance is strong in my neighborhood, as we strongly believe that the Board of Supervisors needs to do everything it can to protect public health and reduce carbon emissions. This issue is personal to me because

The health and climate impacts of continued natural gas use are severe. Children are 42% more likely to develop asthma in homes with gas stoves compared to homes without gas stoves. It's not just asthma -- studies show that replacing gas appliances with electric versions would save hundreds of lives annually in California. We need San Francisco to be a leader on this issue that the rest of the state can follow.

Natural gas combustion in buildings is responsible for a large portion of our city's carbon emissions, which is why we can't afford to delay. Fully electrifying a single house can reduce its carbon emissions by up to 90% depending on how clean the grid is. We are lucky in San Francisco to get most of our energy from carbon-free sources, meaning we get more bang for our buck when we electrify our homes.

While I am in full support of this ordinance, I ask that, to more fully realize the health, climate and economic benefits of electrification and ensure that any exemptions to this important requirement are under legitimately exceptional circumstances, the following changes be made to strengthen the ordinance and implementing regulations:

- 1) eliminate the feasibility exception to the electric-ready requirement;
- 2) create a Clean Energy Buildings Hub that evaluates equity and economic considerations and informs the creation of additional education and technical support resources for affected groups (e.g., small businesses, restaurants, affordable housing, contractors, workforce standards), maximizing opportunities and eliminating barriers to utilization of all-electric new construction to address climate and equity;
- 3) expand and clarify the definition of "Mixed-Fuel Buildings" in the ordinance to include laboratory and industrial buildings, as well as decorative uses of gas;
- 4) provide additional limitations and transparency in the exemption process to ensure any project found exempt for infeasibility is truly in the public interest; and
- 5) eliminate the blanket exemption for commercial kitchens delaying compliance until 2022;

California is burning and our air is unbreathable. There is no more time -- we need bold climate action now. Every building that goes up in San Francisco with gas hookups is just one more building we will have to retrofit for electric heating and appliances later. The prudent thing to do - for our climate, health, and wallets -- is to make sure we aren't digging a deeper hole for ourselves and enact the strongest building electrification ordinance possible. Please support Supervisor Mandelman's ordinance and make San Francisco a climate action leader.

Regards,
Josh Brockmann
1447 McAllister St
San Francisco, CA 94115

-- Sent from **m r** to **Supervisor Catherine Stefani** on Sep 16, 2020 --

My name is m r, and as your constituent I urge you to support Supervisor Mandelman's proposed ordinance requiring all-electric buildings for new construction. Support for this ordinance is strong in my neighborhood, as we strongly believe that the Board of Supervisors needs to do everything it can to protect public health and reduce carbon emissions. This issue is personal to me because

The health and climate impacts of continued natural gas use are severe. Children are 42% more likely to develop asthma in homes with gas stoves compared to homes without gas stoves. It's not just asthma -- studies show that replacing gas appliances with electric versions would save hundreds of lives annually in California. We need San Francisco to be a leader on this issue that the rest of the state can follow.

Natural gas combustion in buildings is responsible for a large portion of our city's carbon emissions, which is why we can't afford to delay. Fully electrifying a single house can reduce its carbon emissions by up to 90% depending on how clean the grid is. We are lucky in San Francisco to get most of our energy from carbon-free sources, meaning we get more bang for our buck when we electrify our homes.

While I am in full support of this ordinance, I ask that, to more fully realize the health, climate and economic benefits of electrification and ensure that any exemptions to this important requirement are under legitimately exceptional circumstances, the following changes be made to strengthen the ordinance and implementing regulations:

- 1) eliminate the feasibility exception to the electric-ready requirement;
- 2) create a Clean Energy Buildings Hub that evaluates equity and economic considerations and informs the creation of additional education and technical support resources for affected groups (e.g., small businesses, restaurants, affordable housing, contractors, workforce standards), maximizing opportunities and eliminating barriers to utilization of all-electric new construction to address climate and equity;
- 3) expand and clarify the definition of "Mixed-Fuel Buildings" in the ordinance to include laboratory and industrial buildings, as well as decorative uses of gas;
- 4) provide additional limitations and transparency in the exemption process to ensure any project found exempt for infeasibility is truly in the public interest; and
- 5) eliminate the blanket exemption for commercial kitchens delaying compliance until 2022;

California is burning and our air is unbreathable. There is no more time -- we need bold climate action now. Every building that goes up in San Francisco with gas hookups is just one more building we will have to retrofit for electric heating and appliances later. The prudent thing to do - for our climate, health, and wallets -- is to make sure we aren't digging a deeper hole for ourselves and enact the strongest building electrification ordinance possible. Please support Supervisor Mandelman's ordinance and make San Francisco a climate action leader.

Regards,
m r
320 10th Ave
San Francisco, CA 94118

-- Sent from **Marie Mika** to **Supervisor Gordon Mar** on Sep 16, 2020 --

My name is Marie Mika, and as your constituent I urge you to support Supervisor Mandelman's proposed ordinance requiring all-electric buildings for new construction. Support for this ordinance is strong in my neighborhood, as we strongly believe that the Board of Supervisors needs to do everything it can to protect public health and reduce carbon emissions. This issue is personal to me because

The health and climate impacts of continued natural gas use are severe. Children are 42% more likely to develop asthma in homes with gas stoves compared to homes without gas stoves. It's not just asthma -- studies show that replacing gas appliances with electric versions would save hundreds of lives annually in California. We need San Francisco to be a leader on this issue that the rest of the state can follow.

Natural gas combustion in buildings is responsible for a large portion of our city's carbon emissions, which is why we can't afford to delay. Fully electrifying a single house can reduce its carbon emissions by up to 90% depending on how clean the grid is. We are lucky in San Francisco to get most of our energy from carbon-free sources, meaning we get more bang for our buck when we electrify our homes.

While I am in full support of this ordinance, I ask that, to more fully realize the health, climate and economic benefits of electrification and ensure that any exemptions to this important requirement are under legitimately exceptional circumstances, the following changes be made to strengthen the ordinance and implementing regulations:

- 1) eliminate the feasibility exception to the electric-ready requirement;
- 2) create a Clean Energy Buildings Hub that evaluates equity and economic considerations and informs the creation of additional education and technical support resources for affected groups (e.g., small businesses, restaurants, affordable housing, contractors, workforce standards), maximizing opportunities and eliminating barriers to utilization of all-electric new construction to address climate and equity;
- 3) expand and clarify the definition of "Mixed-Fuel Buildings" in the ordinance to include laboratory and industrial buildings, as well as decorative uses of gas;
- 4) provide additional limitations and transparency in the exemption process to ensure any project found exempt for infeasibility is truly in the public interest; and
- 5) eliminate the blanket exemption for commercial kitchens delaying compliance until 2022;

California is burning and our air is unbreathable. There is no more time -- we need bold climate action now. Every building that goes up in San Francisco with gas hookups is just one more building we will have to retrofit for electric heating and appliances later. The prudent thing to do - for our climate, health, and wallets -- is to make sure we aren't digging a deeper hole for ourselves and enact the strongest building electrification ordinance possible. Please support Supervisor Mandelman's ordinance and make San Francisco a climate action leader.

Regards,
Marie Mika
2414 47th Ave
San Francisco, CA 94116

-- Sent from **Linda Sherwood** to **Supervisor Sandra Fewer** on Sep 16, 2020 --

My name is Linda Sherwood, and as your constituent I urge you to support Supervisor Mandelman's proposed ordinance requiring all-electric buildings for new construction. Support for this ordinance is strong in my neighborhood, as we strongly believe that the Board of Supervisors needs to do everything it can to protect public health and reduce carbon emissions. This issue is personal to me because

The health and climate impacts of continued natural gas use are severe. Children are 42% more likely to develop asthma in homes with gas stoves compared to homes without gas stoves. It's not just asthma -- studies show that replacing gas appliances with electric versions would save hundreds of lives annually in California. We need San Francisco to be a leader on this issue that the rest of the state can follow.

Natural gas combustion in buildings is responsible for a large portion of our city's carbon emissions, which is why we can't afford to delay. Fully electrifying a single house can reduce its carbon emissions by up to 90% depending on how clean the grid is. We are lucky in San Francisco to get most of our energy from carbon-free sources, meaning we get more bang for our buck when we electrify our homes.

While I am in full support of this ordinance, I ask that, to more fully realize the health, climate and economic benefits of electrification and ensure that any exemptions to this important requirement are under legitimately exceptional circumstances, the following changes be made to strengthen the ordinance and implementing regulations:

- 1) eliminate the feasibility exception to the electric-ready requirement;
- 2) create a Clean Energy Buildings Hub that evaluates equity and economic considerations and informs the creation of additional education and technical support resources for affected groups (e.g., small businesses, restaurants, affordable housing, contractors, workforce standards), maximizing opportunities and eliminating barriers to utilization of all-electric new construction to address climate and equity;
- 3) expand and clarify the definition of "Mixed-Fuel Buildings" in the ordinance to include laboratory and industrial buildings, as well as decorative uses of gas;
- 4) provide additional limitations and transparency in the exemption process to ensure any project found exempt for infeasibility is truly in the public interest; and
- 5) eliminate the blanket exemption for commercial kitchens delaying compliance until 2022;

California is burning and our air is unbreathable. There is no more time -- we need bold climate action now. Every building that goes up in San Francisco with gas hookups is just one more building we will have to retrofit for electric heating and appliances later. The prudent thing to do - for our climate, health, and wallets -- is to make sure we aren't digging a deeper hole for ourselves and enact the strongest building electrification ordinance possible. Please support Supervisor Mandelman's ordinance and make San Francisco a climate action leader.

Regards,
Linda Sherwood
523 22nd Ave
San Francisco, CA 94121

-- Sent from **Denise Peck** to **Supervisor Hillary Ronen** on Sep 17, 2020 --

My name is Denise Peck, and as your constituent I urge you to support Supervisor Mandelman's proposed ordinance requiring all-electric buildings for new construction. Support for this ordinance is strong in my neighborhood, as we strongly believe that the Board of Supervisors needs to do everything it can to protect public health and reduce carbon emissions. This issue is personal to me because

The health and climate impacts of continued natural gas use are severe. Children are 42% more likely to develop asthma in homes with gas stoves compared to homes without gas stoves. It's not just asthma -- studies show that replacing gas appliances with electric versions would save hundreds of lives annually in California. We need San Francisco to be a leader on this issue that the rest of the state can follow.

Natural gas combustion in buildings is responsible for a large portion of our city's carbon emissions, which is why we can't afford to delay. Fully electrifying a single house can reduce its carbon emissions by up to 90% depending on how clean the grid is. We are lucky in San Francisco to get most of our energy from carbon-free sources, meaning we get more bang for our buck when we electrify our homes.

While I am in full support of this ordinance, I ask that, to more fully realize the health, climate and economic benefits of electrification and ensure that any exemptions to this important requirement are under legitimately exceptional circumstances, the following changes be made to strengthen the ordinance and implementing regulations:

- 1) eliminate the feasibility exception to the electric-ready requirement;
- 2) create a Clean Energy Buildings Hub that evaluates equity and economic considerations and informs the creation of additional education and technical support resources for affected groups (e.g., small businesses, restaurants, affordable housing, contractors, workforce standards), maximizing opportunities and eliminating barriers to utilization of all-electric new construction to address climate and equity;
- 3) expand and clarify the definition of "Mixed-Fuel Buildings" in the ordinance to include laboratory and industrial buildings, as well as decorative uses of gas;
- 4) provide additional limitations and transparency in the exemption process to ensure any project found exempt for infeasibility is truly in the public interest; and
- 5) eliminate the blanket exemption for commercial kitchens delaying compliance until 2022;

California is burning and our air is unbreathable. There is no more time -- we need bold climate action now. Every building that goes up in San Francisco with gas hookups is just one more building we will have to retrofit for electric heating and appliances later. The prudent thing to do - for our climate, health, and wallets -- is to make sure we aren't digging a deeper hole for ourselves and enact the strongest building electrification ordinance possible. Please support Supervisor Mandelman's ordinance and make San Francisco a climate action leader.

Regards,
Denise Peck
2130 Harrison St
San Francisco, CA 94110

-- Sent from **David Thompson** to **Supervisor Rafael Mandelman** on Sep 17, 2020 --

My name is David Thompson, and as your constituent I urge you to support Supervisor Mandelman's proposed ordinance requiring all-electric buildings for new construction. Support for this ordinance is strong in my neighborhood, as we strongly believe that the Board of Supervisors needs to do everything it can to protect public health and reduce carbon emissions. This issue is personal to me because

The health and climate impacts of continued natural gas use are severe. Children are 42% more likely to develop asthma in homes with gas stoves compared to homes without gas stoves. It's not just asthma -- studies show that replacing gas appliances with electric versions would save hundreds of lives annually in California. We need San Francisco to be a leader on this issue that the rest of the state can follow.

Natural gas combustion in buildings is responsible for a large portion of our city's carbon emissions, which is why we can't afford to delay. Fully electrifying a single house can reduce its carbon emissions by up to 90% depending on how clean the grid is. We are lucky in San Francisco to get most of our energy from carbon-free sources, meaning we get more bang for our buck when we electrify our homes.

While I am in full support of this ordinance, I ask that, to more fully realize the health, climate and economic benefits of electrification and ensure that any exemptions to this important requirement are under legitimately exceptional circumstances, the following changes be made to strengthen the ordinance and implementing regulations:

- 1) eliminate the feasibility exception to the electric-ready requirement;
- 2) create a Clean Energy Buildings Hub that evaluates equity and economic considerations and informs the creation of additional education and technical support resources for affected groups (e.g., small businesses, restaurants, affordable housing, contractors, workforce standards), maximizing opportunities and eliminating barriers to utilization of all-electric new construction to address climate and equity;
- 3) expand and clarify the definition of "Mixed-Fuel Buildings" in the ordinance to include laboratory and industrial buildings, as well as decorative uses of gas;
- 4) provide additional limitations and transparency in the exemption process to ensure any project found exempt for infeasibility is truly in the public interest; and
- 5) eliminate the blanket exemption for commercial kitchens delaying compliance until 2022;

California is burning and our air is unbreathable. There is no more time -- we need bold climate action now. Every building that goes up in San Francisco with gas hookups is just one more building we will have to retrofit for electric heating and appliances later. The prudent thing to do - for our climate, health, and wallets -- is to make sure we aren't digging a deeper hole for ourselves and enact the strongest building electrification ordinance possible. Please support Supervisor Mandelman's ordinance and make San Francisco a climate action leader.

Regards,
David Thompson
920 Diamond St
San Francisco, CA 94114

-- Sent from **Sarah M** to **Supervisor Norman Yee** on Sep 17, 2020 --

My name is Sarah M, and as your constituent I urge you to support Supervisor Mandelman's proposed ordinance requiring all-electric buildings for new construction. Support for this ordinance is strong in my neighborhood, as we strongly believe that the Board of Supervisors needs to do everything it can to protect public health and reduce carbon emissions. This issue is personal to me because

The health and climate impacts of continued natural gas use are severe. Children are 42% more likely to develop asthma in homes with gas stoves compared to homes without gas stoves. It's not just asthma -- studies show that replacing gas appliances with electric versions would save hundreds of lives annually in California. We need San Francisco to be a leader on this issue that the rest of the state can follow.

Natural gas combustion in buildings is responsible for a large portion of our city's carbon emissions, which is why we can't afford to delay. Fully electrifying a single house can reduce its carbon emissions by up to 90% depending on how clean the grid is. We are lucky in San Francisco to get most of our energy from carbon-free sources, meaning we get more bang for our buck when we electrify our homes.

While I am in full support of this ordinance, I ask that, to more fully realize the health, climate and economic benefits of electrification and ensure that any exemptions to this important requirement are under legitimately exceptional circumstances, the following changes be made to strengthen the ordinance and implementing regulations:

- 1) eliminate the feasibility exception to the electric-ready requirement;
- 2) create a Clean Energy Buildings Hub that evaluates equity and economic considerations and informs the creation of additional education and technical support resources for affected groups (e.g., small businesses, restaurants, affordable housing, contractors, workforce standards), maximizing opportunities and eliminating barriers to utilization of all-electric new construction to address climate and equity;
- 3) expand and clarify the definition of "Mixed-Fuel Buildings" in the ordinance to include laboratory and industrial buildings, as well as decorative uses of gas;
- 4) provide additional limitations and transparency in the exemption process to ensure any project found exempt for infeasibility is truly in the public interest; and
- 5) eliminate the blanket exemption for commercial kitchens delaying compliance until 2022;

California is burning and our air is unbreathable. There is no more time -- we need bold climate action now. Every building that goes up in San Francisco with gas hookups is just one more building we will have to retrofit for electric heating and appliances later. The prudent thing to do - for our climate, health, and wallets -- is to make sure we aren't digging a deeper hole for ourselves and enact the strongest building electrification ordinance possible. Please support Supervisor Mandelman's ordinance and make San Francisco a climate action leader.

Regards,
Sarah M
744 Pacheco St
San Francisco, CA 94116

-- Sent from **Van Rookhuyzen** to **Supervisor Matt Haney** on Sep 18, 2020 --

My name is Van Rookhuyzen, and as your constituent I urge you to support Supervisor Mandelman's proposed ordinance requiring all-electric buildings for new construction. Support for this ordinance is strong in my neighborhood, as we strongly believe that the Board of Supervisors needs to do everything it can to protect public health and reduce carbon emissions. This issue is personal to me because

The health and climate impacts of continued natural gas use are severe. Children are 42% more likely to develop asthma in homes with gas stoves compared to homes without gas stoves. It's not just asthma -- studies show that replacing gas appliances with electric versions would save hundreds of lives annually in California. We need San Francisco to be a leader on this issue that the rest of the state can follow.

Natural gas combustion in buildings is responsible for a large portion of our city's carbon emissions, which is why we can't afford to delay. Fully electrifying a single house can reduce its carbon emissions by up to 90% depending on how clean the grid is. We are lucky in San Francisco to get most of our energy from carbon-free sources, meaning we get more bang for our buck when we electrify our homes.

While I am in full support of this ordinance, I ask that, to more fully realize the health, climate and economic benefits of electrification and ensure that any exemptions to this important requirement are under legitimately exceptional circumstances, the following changes be made to strengthen the ordinance and implementing regulations:

- 1) eliminate the feasibility exception to the electric-ready requirement;
- 2) create a Clean Energy Buildings Hub that evaluates equity and economic considerations and informs the creation of additional education and technical support resources for affected groups (e.g., small businesses, restaurants, affordable housing, contractors, workforce standards), maximizing opportunities and eliminating barriers to utilization of all-electric new construction to address climate and equity;
- 3) expand and clarify the definition of "Mixed-Fuel Buildings" in the ordinance to include laboratory and industrial buildings, as well as decorative uses of gas;
- 4) provide additional limitations and transparency in the exemption process to ensure any project found exempt for infeasibility is truly in the public interest; and
- 5) eliminate the blanket exemption for commercial kitchens delaying compliance until 2022;

California is burning and our air is unbreathable. There is no more time -- we need bold climate action now. Every building that goes up in San Francisco with gas hookups is just one more building we will have to retrofit for electric heating and appliances later. The prudent thing to do - for our climate, health, and wallets -- is to make sure we aren't digging a deeper hole for ourselves and enact the strongest building electrification ordinance possible. Please support Supervisor Mandelman's ordinance and make San Francisco a climate action leader.

Regards,
Van Rookhuyzen
145 Taylor St
San Francisco, CA 94102

-- Sent from **Emma Cervantes** to **Supervisor Dean Preston** on Sep 18, 2020 --

My name is Emma Cervantes, and as your constituent I urge you to support Supervisor Mandelman's proposed ordinance requiring all-electric buildings for new construction. Support for this ordinance is strong in my neighborhood, as we strongly believe that the Board of Supervisors needs to do everything it can to protect public health and reduce carbon emissions. This issue is personal to me because

The health and climate impacts of continued natural gas use are severe. Children are 42% more likely to develop asthma in homes with gas stoves compared to homes without gas stoves. It's not just asthma -- studies show that replacing gas appliances with electric versions would save hundreds of lives annually in California. We need San Francisco to be a leader on this issue that the rest of the state can follow.

Natural gas combustion in buildings is responsible for a large portion of our city's carbon emissions, which is why we can't afford to delay. Fully electrifying a single house can reduce its carbon emissions by up to 90% depending on how clean the grid is. We are lucky in San Francisco to get most of our energy from carbon-free sources, meaning we get more bang for our buck when we electrify our homes.

While I am in full support of this ordinance, I ask that, to more fully realize the health, climate and economic benefits of electrification and ensure that any exemptions to this important requirement are under legitimately exceptional circumstances, the following changes be made to strengthen the ordinance and implementing regulations:

- 1) eliminate the feasibility exception to the electric-ready requirement;
- 2) create a Clean Energy Buildings Hub that evaluates equity and economic considerations and informs the creation of additional education and technical support resources for affected groups (e.g., small businesses, restaurants, affordable housing, contractors, workforce standards), maximizing opportunities and eliminating barriers to utilization of all-electric new construction to address climate and equity;
- 3) expand and clarify the definition of "Mixed-Fuel Buildings" in the ordinance to include laboratory and industrial buildings, as well as decorative uses of gas;
- 4) provide additional limitations and transparency in the exemption process to ensure any project found exempt for infeasibility is truly in the public interest; and
- 5) eliminate the blanket exemption for commercial kitchens delaying compliance until 2022;

California is burning and our air is unbreathable. There is no more time -- we need bold climate action now. Every building that goes up in San Francisco with gas hookups is just one more building we will have to retrofit for electric heating and appliances later. The prudent thing to do - for our climate, health, and wallets -- is to make sure we aren't digging a deeper hole for ourselves and enact the strongest building electrification ordinance possible. Please support Supervisor Mandelman's ordinance and make San Francisco a climate action leader.

Regards,
Emma Cervantes
49 Beideman St
San Francisco, CA 94115

-- Sent from **Kay Weber** to **Supervisor Matt Haney** on Sep 18, 2020 --

My name is Kay Weber, and as your constituent I urge you to support Supervisor Mandelman's proposed ordinance requiring all-electric buildings for new construction. Support for this ordinance is strong in my neighborhood, as we strongly believe that the Board of Supervisors needs to do everything it can to protect public health and reduce carbon emissions. This issue is personal to me because

The health and climate impacts of continued natural gas use are severe. Children are 42% more likely to develop asthma in homes with gas stoves compared to homes without gas stoves. It's not just asthma -- studies show that replacing gas appliances with electric versions would save hundreds of lives annually in California. We need San Francisco to be a leader on this issue that the rest of the state can follow.

Natural gas combustion in buildings is responsible for a large portion of our city's carbon emissions, which is why we can't afford to delay. Fully electrifying a single house can reduce its carbon emissions by up to 90% depending on how clean the grid is. We are lucky in San Francisco to get most of our energy from carbon-free sources, meaning we get more bang for our buck when we electrify our homes.

While I am in full support of this ordinance, I ask that, to more fully realize the health, climate and economic benefits of electrification and ensure that any exemptions to this important requirement are under legitimately exceptional circumstances, the following changes be made to strengthen the ordinance and implementing regulations:

- 1) eliminate the feasibility exception to the electric-ready requirement;
- 2) create a Clean Energy Buildings Hub that evaluates equity and economic considerations and informs the creation of additional education and technical support resources for affected groups (e.g., small businesses, restaurants, affordable housing, contractors, workforce standards), maximizing opportunities and eliminating barriers to utilization of all-electric new construction to address climate and equity;
- 3) expand and clarify the definition of "Mixed-Fuel Buildings" in the ordinance to include laboratory and industrial buildings, as well as decorative uses of gas;
- 4) provide additional limitations and transparency in the exemption process to ensure any project found exempt for infeasibility is truly in the public interest; and
- 5) eliminate the blanket exemption for commercial kitchens delaying compliance until 2022;

California is burning and our air is unbreathable. There is no more time -- we need bold climate action now. Every building that goes up in San Francisco with gas hookups is just one more building we will have to retrofit for electric heating and appliances later. The prudent thing to do - for our climate, health, and wallets -- is to make sure we aren't digging a deeper hole for ourselves and enact the strongest building electrification ordinance possible. Please support Supervisor Mandelman's ordinance and make San Francisco a climate action leader.

Regards,
Kay Weber
111 Jones St
San Francisco, CA 94102

-- Sent from **Constance Walker** to **Supervisor Dean Preston** on Sep 18, 2020 --

My name is Constance Walker, and as your constituent I urge you to support Supervisor Mandelman's proposed ordinance requiring all-electric buildings for new construction. Support for this ordinance is strong in my neighborhood, as we strongly believe that the Board of Supervisors needs to do everything it can to protect public health and reduce carbon emissions. This issue is personal to me because

The health and climate impacts of continued natural gas use are severe. Children are 42% more likely to develop asthma in homes with gas stoves compared to homes without gas stoves. It's not just asthma -- studies show that replacing gas appliances with electric versions would save hundreds of lives annually in California. We need San Francisco to be a leader on this issue that the rest of the state can follow.

Natural gas combustion in buildings is responsible for a large portion of our city's carbon emissions, which is why we can't afford to delay. Fully electrifying a single house can reduce its carbon emissions by up to 90% depending on how clean the grid is. We are lucky in San Francisco to get most of our energy from carbon-free sources, meaning we get more bang for our buck when we electrify our homes.

While I am in full support of this ordinance, I ask that, to more fully realize the health, climate and economic benefits of electrification and ensure that any exemptions to this important requirement are under legitimately exceptional circumstances, the following changes be made to strengthen the ordinance and implementing regulations:

- 1) eliminate the feasibility exception to the electric-ready requirement;
- 2) create a Clean Energy Buildings Hub that evaluates equity and economic considerations and informs the creation of additional education and technical support resources for affected groups (e.g., small businesses, restaurants, affordable housing, contractors, workforce standards), maximizing opportunities and eliminating barriers to utilization of all-electric new construction to address climate and equity;
- 3) expand and clarify the definition of "Mixed-Fuel Buildings" in the ordinance to include laboratory and industrial buildings, as well as decorative uses of gas;
- 4) provide additional limitations and transparency in the exemption process to ensure any project found exempt for infeasibility is truly in the public interest; and
- 5) eliminate the blanket exemption for commercial kitchens delaying compliance until 2022;

California is burning and our air is unbreathable. There is no more time -- we need bold climate action now. Every building that goes up in San Francisco with gas hookups is just one more building we will have to retrofit for electric heating and appliances later. The prudent thing to do - for our climate, health, and wallets -- is to make sure we aren't digging a deeper hole for ourselves and enact the strongest building electrification ordinance possible. Please support Supervisor Mandelman's ordinance and make San Francisco a climate action leader.

Regards,
Constance Walker
709 Frederick St
San Francisco, CA 94117

-- Sent from **Tamara Straus** to **Supervisor Shamann Walton** on Sep 18, 2020 --

My name is Tamara Straus, and as your constituent I urge you to support Supervisor Mandelman's proposed ordinance requiring all-electric buildings for new construction. Support for this ordinance is strong in my neighborhood, as we strongly believe that the Board of Supervisors needs to do everything it can to protect public health and reduce carbon emissions. This issue is personal to me because

The health and climate impacts of continued natural gas use are severe. Children are 42% more likely to develop asthma in homes with gas stoves compared to homes without gas stoves. It's not just asthma -- studies show that replacing gas appliances with electric versions would save hundreds of lives annually in California. We need San Francisco to be a leader on this issue that the rest of the state can follow.

Natural gas combustion in buildings is responsible for a large portion of our city's carbon emissions, which is why we can't afford to delay. Fully electrifying a single house can reduce its carbon emissions by up to 90% depending on how clean the grid is. We are lucky in San Francisco to get most of our energy from carbon-free sources, meaning we get more bang for our buck when we electrify our homes.

While I am in full support of this ordinance, I ask that, to more fully realize the health, climate and economic benefits of electrification and ensure that any exemptions to this important requirement are under legitimately exceptional circumstances, the following changes be made to strengthen the ordinance and implementing regulations:

- 1) eliminate the feasibility exception to the electric-ready requirement;
- 2) create a Clean Energy Buildings Hub that evaluates equity and economic considerations and informs the creation of additional education and technical support resources for affected groups (e.g., small businesses, restaurants, affordable housing, contractors, workforce standards), maximizing opportunities and eliminating barriers to utilization of all-electric new construction to address climate and equity;
- 3) expand and clarify the definition of "Mixed-Fuel Buildings" in the ordinance to include laboratory and industrial buildings, as well as decorative uses of gas;
- 4) provide additional limitations and transparency in the exemption process to ensure any project found exempt for infeasibility is truly in the public interest; and
- 5) eliminate the blanket exemption for commercial kitchens delaying compliance until 2022;

California is burning and our air is unbreathable. There is no more time -- we need bold climate action now. Every building that goes up in San Francisco with gas hookups is just one more building we will have to retrofit for electric heating and appliances later. The prudent thing to do - for our climate, health, and wallets -- is to make sure we aren't digging a deeper hole for ourselves and enact the strongest building electrification ordinance possible. Please support Supervisor Mandelman's ordinance and make San Francisco a climate action leader.

Regards,
Tamara Straus
477 Vermont St
San Francisco, CA 94107

-- Sent from **Lynn Shauinger** to **Supervisor Dean Preston** on Sep 18, 2020 --

My name is Lynn Shauinger, and as your constituent I urge you to support Supervisor Mandelman's proposed ordinance requiring all-electric buildings for new construction. Support for this ordinance is strong in my neighborhood, as we strongly believe that the Board of Supervisors needs to do everything it can to protect public health and reduce carbon emissions. This issue is personal to me because

The health and climate impacts of continued natural gas use are severe. Children are 42% more likely to develop asthma in homes with gas stoves compared to homes without gas stoves. It's not just asthma -- studies show that replacing gas appliances with electric versions would save hundreds of lives annually in California. We need San Francisco to be a leader on this issue that the rest of the state can follow.

Natural gas combustion in buildings is responsible for a large portion of our city's carbon emissions, which is why we can't afford to delay. Fully electrifying a single house can reduce its carbon emissions by up to 90% depending on how clean the grid is. We are lucky in San Francisco to get most of our energy from carbon-free sources, meaning we get more bang for our buck when we electrify our homes.

While I am in full support of this ordinance, I ask that, to more fully realize the health, climate and economic benefits of electrification and ensure that any exemptions to this important requirement are under legitimately exceptional circumstances, the following changes be made to strengthen the ordinance and implementing regulations:

- 1) eliminate the feasibility exception to the electric-ready requirement;
- 2) create a Clean Energy Buildings Hub that evaluates equity and economic considerations and informs the creation of additional education and technical support resources for affected groups (e.g., small businesses, restaurants, affordable housing, contractors, workforce standards), maximizing opportunities and eliminating barriers to utilization of all-electric new construction to address climate and equity;
- 3) expand and clarify the definition of "Mixed-Fuel Buildings" in the ordinance to include laboratory and industrial buildings, as well as decorative uses of gas;
- 4) provide additional limitations and transparency in the exemption process to ensure any project found exempt for infeasibility is truly in the public interest; and
- 5) eliminate the blanket exemption for commercial kitchens delaying compliance until 2022;

California is burning and our air is unbreathable. There is no more time -- we need bold climate action now. Every building that goes up in San Francisco with gas hookups is just one more building we will have to retrofit for electric heating and appliances later. The prudent thing to do - for our climate, health, and wallets -- is to make sure we aren't digging a deeper hole for ourselves and enact the strongest building electrification ordinance possible. Please support Supervisor Mandelman's ordinance and make San Francisco a climate action leader.

Regards,
Lynn Shauinger
941 Oak St
San Francisco, CA 94117

-- Sent from **Jonathan Albizures** to **Supervisor Rafael Mandelman** on Sep 18, 2020 --

My name is Jonathan Albizures, and as your constituent I urge you to support Supervisor Mandelman's proposed ordinance requiring all-electric buildings for new construction. Support for this ordinance is strong in my neighborhood, as we strongly believe that the Board of Supervisors needs to do everything it can to protect public health and reduce carbon emissions. This issue is personal to me because

The health and climate impacts of continued natural gas use are severe. Children are 42% more likely to develop asthma in homes with gas stoves compared to homes without gas stoves. It's not just asthma -- studies show that replacing gas appliances with electric versions would save hundreds of lives annually in California. We need San Francisco to be a leader on this issue that the rest of the state can follow.

Natural gas combustion in buildings is responsible for a large portion of our city's carbon emissions, which is why we can't afford to delay. Fully electrifying a single house can reduce its carbon emissions by up to 90% depending on how clean the grid is. We are lucky in San Francisco to get most of our energy from carbon-free sources, meaning we get more bang for our buck when we electrify our homes.

While I am in full support of this ordinance, I ask that, to more fully realize the health, climate and economic benefits of electrification and ensure that any exemptions to this important requirement are under legitimately exceptional circumstances, the following changes be made to strengthen the ordinance and implementing regulations:

- 1) eliminate the feasibility exception to the electric-ready requirement;
- 2) create a Clean Energy Buildings Hub that evaluates equity and economic considerations and informs the creation of additional education and technical support resources for affected groups (e.g., small businesses, restaurants, affordable housing, contractors, workforce standards), maximizing opportunities and eliminating barriers to utilization of all-electric new construction to address climate and equity;
- 3) expand and clarify the definition of "Mixed-Fuel Buildings" in the ordinance to include laboratory and industrial buildings, as well as decorative uses of gas;
- 4) provide additional limitations and transparency in the exemption process to ensure any project found exempt for infeasibility is truly in the public interest; and
- 5) eliminate the blanket exemption for commercial kitchens delaying compliance until 2022;

California is burning and our air is unbreathable. There is no more time -- we need bold climate action now. Every building that goes up in San Francisco with gas hookups is just one more building we will have to retrofit for electric heating and appliances later. The prudent thing to do - for our climate, health, and wallets -- is to make sure we aren't digging a deeper hole for ourselves and enact the strongest building electrification ordinance possible. Please support Supervisor Mandelman's ordinance and make San Francisco a climate action leader.

Regards,
Jonathan Albizures
66 Corwin St
San Francisco, CA 94114

-- Sent from **Rachel Hinojosa** to **Supervisor Hillary Ronen** on Sep 18, 2020 --

My name is Rachel Hinojosa, and as your constituent I urge you to support Supervisor Mandelman's proposed ordinance requiring all-electric buildings for new construction. Support for this ordinance is strong in my neighborhood, as we strongly believe that the Board of Supervisors needs to do everything it can to protect public health and reduce carbon emissions. This issue is personal to me because

The health and climate impacts of continued natural gas use are severe. Children are 42% more likely to develop asthma in homes with gas stoves compared to homes without gas stoves. It's not just asthma -- studies show that replacing gas appliances with electric versions would save hundreds of lives annually in California. We need San Francisco to be a leader on this issue that the rest of the state can follow.

Natural gas combustion in buildings is responsible for a large portion of our city's carbon emissions, which is why we can't afford to delay. Fully electrifying a single house can reduce its carbon emissions by up to 90% depending on how clean the grid is. We are lucky in San Francisco to get most of our energy from carbon-free sources, meaning we get more bang for our buck when we electrify our homes.

While I am in full support of this ordinance, I ask that, to more fully realize the health, climate and economic benefits of electrification and ensure that any exemptions to this important requirement are under legitimately exceptional circumstances, the following changes be made to strengthen the ordinance and implementing regulations:

- 1) eliminate the feasibility exception to the electric-ready requirement;
- 2) create a Clean Energy Buildings Hub that evaluates equity and economic considerations and informs the creation of additional education and technical support resources for affected groups (e.g., small businesses, restaurants, affordable housing, contractors, workforce standards), maximizing opportunities and eliminating barriers to utilization of all-electric new construction to address climate and equity;
- 3) expand and clarify the definition of "Mixed-Fuel Buildings" in the ordinance to include laboratory and industrial buildings, as well as decorative uses of gas;
- 4) provide additional limitations and transparency in the exemption process to ensure any project found exempt for infeasibility is truly in the public interest; and
- 5) eliminate the blanket exemption for commercial kitchens delaying compliance until 2022;

California is burning and our air is unbreathable. There is no more time -- we need bold climate action now. Every building that goes up in San Francisco with gas hookups is just one more building we will have to retrofit for electric heating and appliances later. The prudent thing to do - for our climate, health, and wallets -- is to make sure we aren't digging a deeper hole for ourselves and enact the strongest building electrification ordinance possible. Please support Supervisor Mandelman's ordinance and make San Francisco a climate action leader.

Regards,
Rachel Hinojosa
130 Kingston St
San Francisco, CA 94110

-- Sent from **Karla Robinson** to **Supervisor Catherine Stefani** on Sep 18, 2020 --

My name is Karla Robinson, and as your constituent I urge you to support Supervisor Mandelman's proposed ordinance requiring all-electric buildings for new construction. Support for this ordinance is strong in my neighborhood, as we strongly believe that the Board of Supervisors needs to do everything it can to protect public health and reduce carbon emissions. This issue is personal to me because

The health and climate impacts of continued natural gas use are severe. Children are 42% more likely to develop asthma in homes with gas stoves compared to homes without gas stoves. It's not just asthma -- studies show that replacing gas appliances with electric versions would save hundreds of lives annually in California. We need San Francisco to be a leader on this issue that the rest of the state can follow.

Natural gas combustion in buildings is responsible for a large portion of our city's carbon emissions, which is why we can't afford to delay. Fully electrifying a single house can reduce its carbon emissions by up to 90% depending on how clean the grid is. We are lucky in San Francisco to get most of our energy from carbon-free sources, meaning we get more bang for our buck when we electrify our homes.

While I am in full support of this ordinance, I ask that, to more fully realize the health, climate and economic benefits of electrification and ensure that any exemptions to this important requirement are under legitimately exceptional circumstances, the following changes be made to strengthen the ordinance and implementing regulations:

- 1) eliminate the feasibility exception to the electric-ready requirement;
- 2) create a Clean Energy Buildings Hub that evaluates equity and economic considerations and informs the creation of additional education and technical support resources for affected groups (e.g., small businesses, restaurants, affordable housing, contractors, workforce standards), maximizing opportunities and eliminating barriers to utilization of all-electric new construction to address climate and equity;
- 3) expand and clarify the definition of "Mixed-Fuel Buildings" in the ordinance to include laboratory and industrial buildings, as well as decorative uses of gas;
- 4) provide additional limitations and transparency in the exemption process to ensure any project found exempt for infeasibility is truly in the public interest; and
- 5) eliminate the blanket exemption for commercial kitchens delaying compliance until 2022;

California is burning and our air is unbreathable. There is no more time -- we need bold climate action now. Every building that goes up in San Francisco with gas hookups is just one more building we will have to retrofit for electric heating and appliances later. The prudent thing to do - for our climate, health, and wallets -- is to make sure we aren't digging a deeper hole for ourselves and enact the strongest building electrification ordinance possible. Please support Supervisor Mandelman's ordinance and make San Francisco a climate action leader.

Regards,
Karla Robinson
2831 Pine St
San Francisco, CA 94115

-- Sent from **Michelle Ghafar** to **Supervisor Norman Yee** on Sep 18, 2020 --

My name is Michelle Ghafar, and as your constituent I urge you to support Supervisor Mandelman's proposed ordinance requiring all-electric buildings for new construction. Support for this ordinance is strong in my neighborhood, as we strongly believe that the Board of Supervisors needs to do everything it can to protect public health and reduce carbon emissions. This issue is personal to me because I'm a lifelong California resident who cares deeply about tackling air pollution and climate change.

The health and climate impacts of continued natural gas use are severe. Children are 42% more likely to develop asthma in homes with gas stoves compared to homes without gas stoves. It's not just asthma -- studies show that replacing gas appliances with electric versions would save hundreds of lives annually in California. We need San Francisco to be a leader on this issue that the rest of the state can follow.

Natural gas combustion in buildings is responsible for a large portion of our city's carbon emissions, which is why we can't afford to delay. Fully electrifying a single house can reduce its carbon emissions by up to 90% depending on how clean the grid is. We are lucky in San Francisco to get most of our energy from carbon-free sources, meaning we get more bang for our buck when we electrify our homes.

While I am in full support of this ordinance, I ask that, to more fully realize the health, climate and economic benefits of electrification and ensure that any exemptions to this important requirement are under legitimately exceptional circumstances, the following changes be made to strengthen the ordinance and implementing regulations:

- 1) eliminate the feasibility exception to the electric-ready requirement;
- 2) create a Clean Energy Buildings Hub that evaluates equity and economic considerations and informs the creation of additional education and technical support resources for affected groups (e.g., small businesses, restaurants, affordable housing, contractors, workforce standards), maximizing opportunities and eliminating barriers to utilization of all-electric new construction to address climate and equity;
- 3) expand and clarify the definition of "Mixed-Fuel Buildings" in the ordinance to include laboratory and industrial buildings, as well as decorative uses of gas;
- 4) provide additional limitations and transparency in the exemption process to ensure any project found exempt for infeasibility is truly in the public interest; and
- 5) eliminate the blanket exemption for commercial kitchens delaying compliance until 2022;

California is burning and our air is unbreathable. There is no more time -- we need bold climate action now. Every building that goes up in San Francisco with gas hookups is just one more building we will have to retrofit for electric heating and appliances later. The prudent thing to do - for our climate, health, and wallets -- is to make sure we aren't digging a deeper hole for ourselves and enact the strongest building electrification ordinance possible. Please support Supervisor Mandelman's ordinance and make San Francisco a climate action leader.

Regards,
Michelle Ghafar
2376 16th Ave
San Francisco, CA 94116

-- Sent from **Jill Fitzsimmons** to **Supervisor Catherine Stefani** on Sep 18, 2020 --

My name is Jill Fitzsimmons, and as your constituent I urge you to support Supervisor Mandelman's proposed ordinance requiring all-electric buildings for new construction. Support for this ordinance is strong in my neighborhood, as we strongly believe that the Board of Supervisors needs to do everything it can to protect public health and reduce carbon emissions. This issue is personal to me because

The health and climate impacts of continued natural gas use are severe. Children are 42% more likely to develop asthma in homes with gas stoves compared to homes without gas stoves. It's not just asthma -- studies show that replacing gas appliances with electric versions would save hundreds of lives annually in California. We need San Francisco to be a leader on this issue that the rest of the state can follow.

Natural gas combustion in buildings is responsible for a large portion of our city's carbon emissions, which is why we can't afford to delay. Fully electrifying a single house can reduce its carbon emissions by up to 90% depending on how clean the grid is. We are lucky in San Francisco to get most of our energy from carbon-free sources, meaning we get more bang for our buck when we electrify our homes.

While I am in full support of this ordinance, I ask that, to more fully realize the health, climate and economic benefits of electrification and ensure that any exemptions to this important requirement are under legitimately exceptional circumstances, the following changes be made to strengthen the ordinance and implementing regulations:

- 1) eliminate the feasibility exception to the electric-ready requirement;
- 2) create a Clean Energy Buildings Hub that evaluates equity and economic considerations and informs the creation of additional education and technical support resources for affected groups (e.g., small businesses, restaurants, affordable housing, contractors, workforce standards), maximizing opportunities and eliminating barriers to utilization of all-electric new construction to address climate and equity;
- 3) expand and clarify the definition of "Mixed-Fuel Buildings" in the ordinance to include laboratory and industrial buildings, as well as decorative uses of gas;
- 4) provide additional limitations and transparency in the exemption process to ensure any project found exempt for infeasibility is truly in the public interest; and
- 5) eliminate the blanket exemption for commercial kitchens delaying compliance until 2022;

California is burning and our air is unbreathable. There is no more time -- we need bold climate action now. Every building that goes up in San Francisco with gas hookups is just one more building we will have to retrofit for electric heating and appliances later. The prudent thing to do - for our climate, health, and wallets -- is to make sure we aren't digging a deeper hole for ourselves and enact the strongest building electrification ordinance possible. Please support Supervisor Mandelman's ordinance and make San Francisco a climate action leader.

Regards,
Jill Fitzsimmons
1101 Francisco St
San Francisco, CA 94109

-- Sent from **Marie Logan** to **Supervisor Dean Preston** on Sep 18, 2020 --

My name is Marie Logan, and as your constituent I urge you to support Supervisor Mandelman's proposed ordinance requiring all-electric buildings for new construction. Support for this ordinance is strong in my neighborhood, as we strongly believe that the Board of Supervisors needs to do everything it can to protect public health and reduce carbon emissions. This issue is personal to me because

The health and climate impacts of continued natural gas use are severe. Children are 42% more likely to develop asthma in homes with gas stoves compared to homes without gas stoves. It's not just asthma -- studies show that replacing gas appliances with electric versions would save hundreds of lives annually in California. We need San Francisco to be a leader on this issue that the rest of the state can follow.

Natural gas combustion in buildings is responsible for a large portion of our city's carbon emissions, which is why we can't afford to delay. Fully electrifying a single house can reduce its carbon emissions by up to 90% depending on how clean the grid is. We are lucky in San Francisco to get most of our energy from carbon-free sources, meaning we get more bang for our buck when we electrify our homes.

While I am in full support of this ordinance, I ask that, to more fully realize the health, climate and economic benefits of electrification and ensure that any exemptions to this important requirement are under legitimately exceptional circumstances, the following changes be made to strengthen the ordinance and implementing regulations:

- 1) eliminate the feasibility exception to the electric-ready requirement;
- 2) create a Clean Energy Buildings Hub that evaluates equity and economic considerations and informs the creation of additional education and technical support resources for affected groups (e.g., small businesses, restaurants, affordable housing, contractors, workforce standards), maximizing opportunities and eliminating barriers to utilization of all-electric new construction to address climate and equity;
- 3) expand and clarify the definition of "Mixed-Fuel Buildings" in the ordinance to include laboratory and industrial buildings, as well as decorative uses of gas;
- 4) provide additional limitations and transparency in the exemption process to ensure any project found exempt for infeasibility is truly in the public interest; and
- 5) eliminate the blanket exemption for commercial kitchens delaying compliance until 2022;

California is burning and our air is unbreathable. There is no more time -- we need bold climate action now. Every building that goes up in San Francisco with gas hookups is just one more building we will have to retrofit for electric heating and appliances later. The prudent thing to do - for our climate, health, and wallets -- is to make sure we aren't digging a deeper hole for ourselves and enact the strongest building electrification ordinance possible. Please support Supervisor Mandelman's ordinance and make San Francisco a climate action leader.

Regards,
Marie Logan
155 Page St
San Francisco, CA 94102

-- Sent from **Dalton Fusco** to **Supervisor Sandra Fewer** on Sep 18, 2020 --

My name is Dalton Fusco, and as your constituent I urge you to support Supervisor Mandelman's proposed ordinance requiring all-electric buildings for new construction. Support for this ordinance is strong in my neighborhood, as we strongly believe that the Board of Supervisors needs to do everything it can to protect public health and reduce carbon emissions. This issue is personal to me because

The health and climate impacts of continued natural gas use are severe. Children are 42% more likely to develop asthma in homes with gas stoves compared to homes without gas stoves. It's not just asthma -- studies show that replacing gas appliances with electric versions would save hundreds of lives annually in California. We need San Francisco to be a leader on this issue that the rest of the state can follow.

Natural gas combustion in buildings is responsible for a large portion of our city's carbon emissions, which is why we can't afford to delay. Fully electrifying a single house can reduce its carbon emissions by up to 90% depending on how clean the grid is. We are lucky in San Francisco to get most of our energy from carbon-free sources, meaning we get more bang for our buck when we electrify our homes.

While I am in full support of this ordinance, I ask that, to more fully realize the health, climate and economic benefits of electrification and ensure that any exemptions to this important requirement are under legitimately exceptional circumstances, the following changes be made to strengthen the ordinance and implementing regulations:

- 1) eliminate the feasibility exception to the electric-ready requirement;
- 2) create a Clean Energy Buildings Hub that evaluates equity and economic considerations and informs the creation of additional education and technical support resources for affected groups (e.g., small businesses, restaurants, affordable housing, contractors, workforce standards), maximizing opportunities and eliminating barriers to utilization of all-electric new construction to address climate and equity;
- 3) expand and clarify the definition of "Mixed-Fuel Buildings" in the ordinance to include laboratory and industrial buildings, as well as decorative uses of gas;
- 4) provide additional limitations and transparency in the exemption process to ensure any project found exempt for infeasibility is truly in the public interest; and
- 5) eliminate the blanket exemption for commercial kitchens delaying compliance until 2022;

California is burning and our air is unbreathable. There is no more time -- we need bold climate action now. Every building that goes up in San Francisco with gas hookups is just one more building we will have to retrofit for electric heating and appliances later. The prudent thing to do - for our climate, health, and wallets -- is to make sure we aren't digging a deeper hole for ourselves and enact the strongest building electrification ordinance possible. Please support Supervisor Mandelman's ordinance and make San Francisco a climate action leader.

Regards,
Dalton Fusco
646 10th Ave
San Francisco, CA 94118

-- Sent from **Lev Malevanchik** to **Supervisor Dean Preston** on Sep 18, 2020 --

My name is Lev Malevanchik, and as your constituent I urge you to support Supervisor Mandelman's proposed ordinance requiring all-electric buildings for new construction. Support for this ordinance is strong in my neighborhood, as we strongly believe that the Board of Supervisors needs to do everything it can to protect public health and reduce carbon emissions. This issue is personal to me because

The health and climate impacts of continued natural gas use are severe. Children are 42% more likely to develop asthma in homes with gas stoves compared to homes without gas stoves. It's not just asthma -- studies show that replacing gas appliances with electric versions would save hundreds of lives annually in California. We need San Francisco to be a leader on this issue that the rest of the state can follow.

Natural gas combustion in buildings is responsible for a large portion of our city's carbon emissions, which is why we can't afford to delay. Fully electrifying a single house can reduce its carbon emissions by up to 90% depending on how clean the grid is. We are lucky in San Francisco to get most of our energy from carbon-free sources, meaning we get more bang for our buck when we electrify our homes.

While I am in full support of this ordinance, I ask that, to more fully realize the health, climate and economic benefits of electrification and ensure that any exemptions to this important requirement are under legitimately exceptional circumstances, the following changes be made to strengthen the ordinance and implementing regulations:

- 1) eliminate the feasibility exception to the electric-ready requirement;
- 2) create a Clean Energy Buildings Hub that evaluates equity and economic considerations and informs the creation of additional education and technical support resources for affected groups (e.g., small businesses, restaurants, affordable housing, contractors, workforce standards), maximizing opportunities and eliminating barriers to utilization of all-electric new construction to address climate and equity;
- 3) expand and clarify the definition of "Mixed-Fuel Buildings" in the ordinance to include laboratory and industrial buildings, as well as decorative uses of gas;
- 4) provide additional limitations and transparency in the exemption process to ensure any project found exempt for infeasibility is truly in the public interest; and
- 5) eliminate the blanket exemption for commercial kitchens delaying compliance until 2022;

California is burning and our air is unbreathable. There is no more time -- we need bold climate action now. Every building that goes up in San Francisco with gas hookups is just one more building we will have to retrofit for electric heating and appliances later. The prudent thing to do - for our climate, health, and wallets -- is to make sure we aren't digging a deeper hole for ourselves and enact the strongest building electrification ordinance possible. Please support Supervisor Mandelman's ordinance and make San Francisco a climate action leader.

Regards,
Lev Malevanchik
155 Page St
San Francisco, CA 94102

-- Sent from **Saideh Morales** to **Supervisor Gordon Mar** on Sep 18, 2020 --

My name is Saideh herrera and as your constituent I urge you to support Supervisor Mandelman's proposed ordinance requiring all-electric buildings for new construction. Support for this ordinance is strong in my neighborhood, as we strongly believe that the Board of Supervisors needs to do everything it can to protect public health and reduce carbon emissions. This issue is personal to me because

The health and climate impacts of continued natural gas use are severe. Children are 42% more likely to develop asthma in homes with gas stoves compared to homes without gas stoves. It's not just asthma -- studies show that replacing gas appliances with electric versions would save hundreds of lives annually in California. We need San Francisco to be a leader on this issue that the rest of the state can follow.

Natural gas combustion in buildings is responsible for a large portion of our city's carbon emissions, which is why we can't afford to delay. Fully electrifying a single house can reduce its carbon emissions by up to 90% depending on how clean the grid is. We are lucky in San Francisco to get most of our energy from carbon-free sources, meaning we get more bang for our buck when we electrify our homes.

While I am in full support of this ordinance, I ask that, to more fully realize the health, climate and economic benefits of electrification and ensure that any exemptions to this important requirement are under legitimately exceptional circumstances, the following changes be made to strengthen the ordinance and implementing regulations:

- 1) eliminate the feasibility exception to the electric-ready requirement;
- 2) create a Clean Energy Buildings Hub that evaluates equity and economic considerations and informs the creation of additional education and technical support resources for affected groups (e.g., small businesses, restaurants, affordable housing, contractors, workforce standards), maximizing opportunities and eliminating barriers to utilization of all-electric new construction to address climate and equity;
- 3) expand and clarify the definition of "Mixed-Fuel Buildings" in the ordinance to include laboratory and industrial buildings, as well as decorative uses of gas;
- 4) provide additional limitations and transparency in the exemption process to ensure any project found exempt for infeasibility is truly in the public interest; and
- 5) eliminate the blanket exemption for commercial kitchens delaying compliance until 2022;

California is burning and our air is unbreathable. There is no more time -- we need bold climate action now. Every building that goes up in San Francisco with gas hookups is just one more building we will have to retrofit for electric heating and appliances later. The prudent thing to do - for our climate, health, and wallets -- is to make sure we aren't digging a deeper hole for ourselves and enact the strongest building electrification ordinance possible. Please support Supervisor Mandelman's ordinance and make San Francisco a climate action leader.

Regards,
Saideh Morales
1550 48th Ave
San Francisco, CA 94122

-- Sent from **Sarah Davis** to **Supervisor Ahsha Safai** on Sep 18, 2020 --

My name is Sarah Davis, and as your constituent I urge you to support Supervisor Mandelman's proposed ordinance requiring all-electric buildings for new construction. Support for this ordinance is strong in my neighborhood, as we strongly believe that the Board of Supervisors needs to do everything it can to protect public health and reduce carbon emissions. This issue is personal to me because

The health and climate impacts of continued natural gas use are severe. Children are 42% more likely to develop asthma in homes with gas stoves compared to homes without gas stoves. It's not just asthma -- studies show that replacing gas appliances with electric versions would save hundreds of lives annually in California. We need San Francisco to be a leader on this issue that the rest of the state can follow.

Natural gas combustion in buildings is responsible for a large portion of our city's carbon emissions, which is why we can't afford to delay. Fully electrifying a single house can reduce its carbon emissions by up to 90% depending on how clean the grid is. We are lucky in San Francisco to get most of our energy from carbon-free sources, meaning we get more bang for our buck when we electrify our homes.

While I am in full support of this ordinance, I ask that, to more fully realize the health, climate and economic benefits of electrification and ensure that any exemptions to this important requirement are under legitimately exceptional circumstances, the following changes be made to strengthen the ordinance and implementing regulations:

- 1) eliminate the feasibility exception to the electric-ready requirement;
- 2) create a Clean Energy Buildings Hub that evaluates equity and economic considerations and informs the creation of additional education and technical support resources for affected groups (e.g., small businesses, restaurants, affordable housing, contractors, workforce standards), maximizing opportunities and eliminating barriers to utilization of all-electric new construction to address climate and equity;
- 3) expand and clarify the definition of "Mixed-Fuel Buildings" in the ordinance to include laboratory and industrial buildings, as well as decorative uses of gas;
- 4) provide additional limitations and transparency in the exemption process to ensure any project found exempt for infeasibility is truly in the public interest; and
- 5) eliminate the blanket exemption for commercial kitchens delaying compliance until 2022;

California is burning and our air is unbreathable. There is no more time -- we need bold climate action now. Every building that goes up in San Francisco with gas hookups is just one more building we will have to retrofit for electric heating and appliances later. The prudent thing to do - for our climate, health, and wallets -- is to make sure we aren't digging a deeper hole for ourselves and enact the strongest building electrification ordinance possible. Please support Supervisor Mandelman's ordinance and make San Francisco a climate action leader.

Regards,
Sarah Davis
742 Avalon Ave
San Francisco, CA 94112

-- Sent from **Val laurent** to **Supervisor Aaron Peskin** on Sep 18, 2020 --

My name is Val laurent, and as your constituent I urge you to support Supervisor Mandelman's proposed ordinance requiring all-electric buildings for new construction. Support for this ordinance is strong in my neighborhood, as we strongly believe that the Board of Supervisors needs to do everything it can to protect public health and reduce carbon emissions. This issue is personal to me because

The health and climate impacts of continued natural gas use are severe. Children are 42% more likely to develop asthma in homes with gas stoves compared to homes without gas stoves. It's not just asthma -- studies show that replacing gas appliances with electric versions would save hundreds of lives annually in California. We need San Francisco to be a leader on this issue that the rest of the state can follow.

Natural gas combustion in buildings is responsible for a large portion of our city's carbon emissions, which is why we can't afford to delay. Fully electrifying a single house can reduce its carbon emissions by up to 90% depending on how clean the grid is. We are lucky in San Francisco to get most of our energy from carbon-free sources, meaning we get more bang for our buck when we electrify our homes.

While I am in full support of this ordinance, I ask that, to more fully realize the health, climate and economic benefits of electrification and ensure that any exemptions to this important requirement are under legitimately exceptional circumstances, the following changes be made to strengthen the ordinance and implementing regulations:

- 1) eliminate the feasibility exception to the electric-ready requirement;
- 2) create a Clean Energy Buildings Hub that evaluates equity and economic considerations and informs the creation of additional education and technical support resources for affected groups (e.g., small businesses, restaurants, affordable housing, contractors, workforce standards), maximizing opportunities and eliminating barriers to utilization of all-electric new construction to address climate and equity;
- 3) expand and clarify the definition of "Mixed-Fuel Buildings" in the ordinance to include laboratory and industrial buildings, as well as decorative uses of gas;
- 4) provide additional limitations and transparency in the exemption process to ensure any project found exempt for infeasibility is truly in the public interest; and
- 5) eliminate the blanket exemption for commercial kitchens delaying compliance until 2022;

California is burning and our air is unbreathable. There is no more time -- we need bold climate action now. Every building that goes up in San Francisco with gas hookups is just one more building we will have to retrofit for electric heating and appliances later. The prudent thing to do - for our climate, health, and wallets -- is to make sure we aren't digging a deeper hole for ourselves and enact the strongest building electrification ordinance possible. Please support Supervisor Mandelman's ordinance and make San Francisco a climate action leader.

Regards,
Val laurent
1680 Clay St
San Francisco, CA 94109

-- Sent from **Miranda Fox** to **Supervisor Rafael Mandelman** on Sep 18, 2020 --

My name is Miranda Fox, and as your constituent I urge you to support Supervisor Mandelman's proposed ordinance requiring all-electric buildings for new construction. Support for this ordinance is strong in my neighborhood, as we strongly believe that the Board of Supervisors needs to do everything it can to protect public health and reduce carbon emissions. This issue is personal to me because

The health and climate impacts of continued natural gas use are severe. Children are 42% more likely to develop asthma in homes with gas stoves compared to homes without gas stoves. It's not just asthma -- studies show that replacing gas appliances with electric versions would save hundreds of lives annually in California. We need San Francisco to be a leader on this issue that the rest of the state can follow.

Natural gas combustion in buildings is responsible for a large portion of our city's carbon emissions, which is why we can't afford to delay. Fully electrifying a single house can reduce its carbon emissions by up to 90% depending on how clean the grid is. We are lucky in San Francisco to get most of our energy from carbon-free sources, meaning we get more bang for our buck when we electrify our homes.

While I am in full support of this ordinance, I ask that, to more fully realize the health, climate and economic benefits of electrification and ensure that any exemptions to this important requirement are under legitimately exceptional circumstances, the following changes be made to strengthen the ordinance and implementing regulations:

- 1) eliminate the feasibility exception to the electric-ready requirement;
- 2) create a Clean Energy Buildings Hub that evaluates equity and economic considerations and informs the creation of additional education and technical support resources for affected groups (e.g., small businesses, restaurants, affordable housing, contractors, workforce standards), maximizing opportunities and eliminating barriers to utilization of all-electric new construction to address climate and equity;
- 3) expand and clarify the definition of "Mixed-Fuel Buildings" in the ordinance to include laboratory and industrial buildings, as well as decorative uses of gas;
- 4) provide additional limitations and transparency in the exemption process to ensure any project found exempt for infeasibility is truly in the public interest; and
- 5) eliminate the blanket exemption for commercial kitchens delaying compliance until 2022;

California is burning and our air is unbreathable. There is no more time -- we need bold climate action now. Every building that goes up in San Francisco with gas hookups is just one more building we will have to retrofit for electric heating and appliances later. The prudent thing to do - for our climate, health, and wallets -- is to make sure we aren't digging a deeper hole for ourselves and enact the strongest building electrification ordinance possible. Please support Supervisor Mandelman's ordinance and make San Francisco a climate action leader.

Regards,
Miranda Fox
396 San Jose Avenue
San Francisco, CA 94110

-- Sent from **Kylie Cobb** to **Supervisor Catherine Stefani** on Sep 18, 2020 --

My name is Kylie Cobb, and as your constituent I urge you to support Supervisor Mandelman's proposed ordinance requiring all-electric buildings for new construction. Support for this ordinance is strong in my neighborhood, as we strongly believe that the Board of Supervisors needs to do everything it can to protect public health and reduce carbon emissions. This issue is personal to me because

The health and climate impacts of continued natural gas use are severe. Children are 42% more likely to develop asthma in homes with gas stoves compared to homes without gas stoves. It's not just asthma -- studies show that replacing gas appliances with electric versions would save hundreds of lives annually in California. We need San Francisco to be a leader on this issue that the rest of the state can follow.

Natural gas combustion in buildings is responsible for a large portion of our city's carbon emissions, which is why we can't afford to delay. Fully electrifying a single house can reduce its carbon emissions by up to 90% depending on how clean the grid is. We are lucky in San Francisco to get most of our energy from carbon-free sources, meaning we get more bang for our buck when we electrify our homes.

While I am in full support of this ordinance, I ask that, to more fully realize the health, climate and economic benefits of electrification and ensure that any exemptions to this important requirement are under legitimately exceptional circumstances, the following changes be made to strengthen the ordinance and implementing regulations:

- 1) eliminate the feasibility exception to the electric-ready requirement;
- 2) create a Clean Energy Buildings Hub that evaluates equity and economic considerations and informs the creation of additional education and technical support resources for affected groups (e.g., small businesses, restaurants, affordable housing, contractors, workforce standards), maximizing opportunities and eliminating barriers to utilization of all-electric new construction to address climate and equity;
- 3) expand and clarify the definition of "Mixed-Fuel Buildings" in the ordinance to include laboratory and industrial buildings, as well as decorative uses of gas;
- 4) provide additional limitations and transparency in the exemption process to ensure any project found exempt for infeasibility is truly in the public interest; and
- 5) eliminate the blanket exemption for commercial kitchens delaying compliance until 2022;

California is burning and our air is unbreathable. There is no more time -- we need bold climate action now. Every building that goes up in San Francisco with gas hookups is just one more building we will have to retrofit for electric heating and appliances later. The prudent thing to do - for our climate, health, and wallets -- is to make sure we aren't digging a deeper hole for ourselves and enact the strongest building electrification ordinance possible. Please support Supervisor Mandelman's ordinance and make San Francisco a climate action leader.

Regards,
Kylie Cobb
2085 Sacramento St
San Francisco, CA 94109

-- Sent from **Maria Hilario** to **Supervisor Aaron Peskin** on Sep 18, 2020 --

My name is Maria Hilario, and as your constituent I urge you to support Supervisor Mandelman's proposed ordinance requiring all-electric buildings for new construction. Support for this ordinance is strong in my neighborhood, as we strongly believe that the Board of Supervisors needs to do everything it can to protect public health and reduce carbon emissions. This issue is personal to me because

The health and climate impacts of continued natural gas use are severe. Children are 42% more likely to develop asthma in homes with gas stoves compared to homes without gas stoves. It's not just asthma -- studies show that replacing gas appliances with electric versions would save hundreds of lives annually in California. We need San Francisco to be a leader on this issue that the rest of the state can follow.

Natural gas combustion in buildings is responsible for a large portion of our city's carbon emissions, which is why we can't afford to delay. Fully electrifying a single house can reduce its carbon emissions by up to 90% depending on how clean the grid is. We are lucky in San Francisco to get most of our energy from carbon-free sources, meaning we get more bang for our buck when we electrify our homes.

While I am in full support of this ordinance, I ask that, to more fully realize the health, climate and economic benefits of electrification and ensure that any exemptions to this important requirement are under legitimately exceptional circumstances, the following changes be made to strengthen the ordinance and implementing regulations:

- 1) eliminate the feasibility exception to the electric-ready requirement;
- 2) create a Clean Energy Buildings Hub that evaluates equity and economic considerations and informs the creation of additional education and technical support resources for affected groups (e.g., small businesses, restaurants, affordable housing, contractors, workforce standards), maximizing opportunities and eliminating barriers to utilization of all-electric new construction to address climate and equity;
- 3) expand and clarify the definition of "Mixed-Fuel Buildings" in the ordinance to include laboratory and industrial buildings, as well as decorative uses of gas;
- 4) provide additional limitations and transparency in the exemption process to ensure any project found exempt for infeasibility is truly in the public interest; and
- 5) eliminate the blanket exemption for commercial kitchens delaying compliance until 2022;

California is burning and our air is unbreathable. There is no more time -- we need bold climate action now. Every building that goes up in San Francisco with gas hookups is just one more building we will have to retrofit for electric heating and appliances later. The prudent thing to do - for our climate, health, and wallets -- is to make sure we aren't digging a deeper hole for ourselves and enact the strongest building electrification ordinance possible. Please support Supervisor Mandelman's ordinance and make San Francisco a climate action leader.

Regards,
Maria Hilario
72 Lynch St
San Francisco, CA 94109

-- Sent from **Jesse DeRose** to **Supervisor Rafael Mandelman** on Sep 19, 2020 --

My name is Jesse DeRose, and as your constituent I urge you to support Supervisor Mandelman's proposed ordinance requiring all-electric buildings for new construction. Support for this ordinance is strong in my neighborhood, as we strongly believe that the Board of Supervisors needs to do everything it can to protect public health and reduce carbon emissions. This issue is personal to me because

The health and climate impacts of continued natural gas use are severe. Children are 42% more likely to develop asthma in homes with gas stoves compared to homes without gas stoves. It's not just asthma -- studies show that replacing gas appliances with electric versions would save hundreds of lives annually in California. We need San Francisco to be a leader on this issue that the rest of the state can follow.

Natural gas combustion in buildings is responsible for a large portion of our city's carbon emissions, which is why we can't afford to delay. Fully electrifying a single house can reduce its carbon emissions by up to 90% depending on how clean the grid is. We are lucky in San Francisco to get most of our energy from carbon-free sources, meaning we get more bang for our buck when we electrify our homes.

While I am in full support of this ordinance, I ask that, to more fully realize the health, climate and economic benefits of electrification and ensure that any exemptions to this important requirement are under legitimately exceptional circumstances, the following changes be made to strengthen the ordinance and implementing regulations:

- 1) eliminate the feasibility exception to the electric-ready requirement;
- 2) create a Clean Energy Buildings Hub that evaluates equity and economic considerations and informs the creation of additional education and technical support resources for affected groups (e.g., small businesses, restaurants, affordable housing, contractors, workforce standards), maximizing opportunities and eliminating barriers to utilization of all-electric new construction to address climate and equity;
- 3) expand and clarify the definition of "Mixed-Fuel Buildings" in the ordinance to include laboratory and industrial buildings, as well as decorative uses of gas;
- 4) provide additional limitations and transparency in the exemption process to ensure any project found exempt for infeasibility is truly in the public interest; and
- 5) eliminate the blanket exemption for commercial kitchens delaying compliance until 2022;

California is burning and our air is unbreathable. There is no more time -- we need bold climate action now. Every building that goes up in San Francisco with gas hookups is just one more building we will have to retrofit for electric heating and appliances later. The prudent thing to do - for our climate, health, and wallets -- is to make sure we aren't digging a deeper hole for ourselves and enact the strongest building electrification ordinance possible. Please support Supervisor Mandelman's ordinance and make San Francisco a climate action leader.

Regards,
Jesse DeRose
3828 17th St
San Francisco, CA 94114

-- Sent from **Macy McCallister** to **Supervisor Catherine Stefani** on Sep 19, 2020 --

My name is Macy McCallister, and as your constituent I urge you to support Supervisor Mandelman's proposed ordinance requiring all-electric buildings for new construction. Support for this ordinance is strong in my neighborhood, as we strongly believe that the Board of Supervisors needs to do everything it can to protect public health and reduce carbon emissions. This issue is personal to me because

The health and climate impacts of continued natural gas use are severe. Children are 42% more likely to develop asthma in homes with gas stoves compared to homes without gas stoves. It's not just asthma -- studies show that replacing gas appliances with electric versions would save hundreds of lives annually in California. We need San Francisco to be a leader on this issue that the rest of the state can follow.

Natural gas combustion in buildings is responsible for a large portion of our city's carbon emissions, which is why we can't afford to delay. Fully electrifying a single house can reduce its carbon emissions by up to 90% depending on how clean the grid is. We are lucky in San Francisco to get most of our energy from carbon-free sources, meaning we get more bang for our buck when we electrify our homes.

While I am in full support of this ordinance, I ask that, to more fully realize the health, climate and economic benefits of electrification and ensure that any exemptions to this important requirement are under legitimately exceptional circumstances, the following changes be made to strengthen the ordinance and implementing regulations:

- 1) eliminate the feasibility exception to the electric-ready requirement;
- 2) create a Clean Energy Buildings Hub that evaluates equity and economic considerations and informs the creation of additional education and technical support resources for affected groups (e.g., small businesses, restaurants, affordable housing, contractors, workforce standards), maximizing opportunities and eliminating barriers to utilization of all-electric new construction to address climate and equity;
- 3) expand and clarify the definition of "Mixed-Fuel Buildings" in the ordinance to include laboratory and industrial buildings, as well as decorative uses of gas;
- 4) provide additional limitations and transparency in the exemption process to ensure any project found exempt for infeasibility is truly in the public interest; and
- 5) eliminate the blanket exemption for commercial kitchens delaying compliance until 2022;

California is burning and our air is unbreathable. There is no more time -- we need bold climate action now. Every building that goes up in San Francisco with gas hookups is just one more building we will have to retrofit for electric heating and appliances later. The prudent thing to do - for our climate, health, and wallets -- is to make sure we aren't digging a deeper hole for ourselves and enact the strongest building electrification ordinance possible. Please support Supervisor Mandelman's ordinance and make San Francisco a climate action leader.

Regards,
Macy McCallister
2418 Washington St
San Francisco, CA 94115

-- Sent from **Celia Peachey** to **Supervisor Aaron Peskin** on Sep 20, 2020 --

My name is Celia Peachey, and as your constituent I urge you to support Supervisor Mandelman's proposed ordinance requiring all-electric buildings for new construction. Support for this ordinance is strong in my neighborhood, as we strongly believe that the Board of Supervisors needs to do everything it can to protect public health and reduce carbon emissions. This issue is personal to me because

The health and climate impacts of continued natural gas use are severe. Children are 42% more likely to develop asthma in homes with gas stoves compared to homes without gas stoves. It's not just asthma -- studies show that replacing gas appliances with electric versions would save hundreds of lives annually in California. We need San Francisco to be a leader on this issue that the rest of the state can follow.

Natural gas combustion in buildings is responsible for a large portion of our city's carbon emissions, which is why we can't afford to delay. Fully electrifying a single house can reduce its carbon emissions by up to 90% depending on how clean the grid is. We are lucky in San Francisco to get most of our energy from carbon-free sources, meaning we get more bang for our buck when we electrify our homes.

While I am in full support of this ordinance, I ask that, to more fully realize the health, climate and economic benefits of electrification and ensure that any exemptions to this important requirement are under legitimately exceptional circumstances, the following changes be made to strengthen the ordinance and implementing regulations:

- 1) eliminate the feasibility exception to the electric-ready requirement;
- 2) create a Clean Energy Buildings Hub that evaluates equity and economic considerations and informs the creation of additional education and technical support resources for affected groups (e.g., small businesses, restaurants, affordable housing, contractors, workforce standards), maximizing opportunities and eliminating barriers to utilization of all-electric new construction to address climate and equity;
- 3) expand and clarify the definition of "Mixed-Fuel Buildings" in the ordinance to include laboratory and industrial buildings, as well as decorative uses of gas;
- 4) provide additional limitations and transparency in the exemption process to ensure any project found exempt for infeasibility is truly in the public interest; and
- 5) eliminate the blanket exemption for commercial kitchens delaying compliance until 2022;

California is burning and our air is unbreathable. There is no more time -- we need bold climate action now. Every building that goes up in San Francisco with gas hookups is just one more building we will have to retrofit for electric heating and appliances later. The prudent thing to do - for our climate, health, and wallets -- is to make sure we aren't digging a deeper hole for ourselves and enact the strongest building electrification ordinance possible. Please support Supervisor Mandelman's ordinance and make San Francisco a climate action leader.

Regards,
Celia Peachey
1746 Hyde St
San Francisco, CA 94109

-- Sent from **Shelley Kuang** to **Supervisor Shamann Walton** on Sep 20, 2020 --

My name is Shelley Kuang, and as your constituent I urge you to support Supervisor Mandelman's proposed ordinance requiring all-electric buildings for new construction. Support for this ordinance is strong in my neighborhood, as we strongly believe that the Board of Supervisors needs to do everything it can to protect public health and reduce carbon emissions. This issue is personal to me because

The health and climate impacts of continued natural gas use are severe. Children are 42% more likely to develop asthma in homes with gas stoves compared to homes without gas stoves. It's not just asthma -- studies show that replacing gas appliances with electric versions would save hundreds of lives annually in California. We need San Francisco to be a leader on this issue that the rest of the state can follow.

Natural gas combustion in buildings is responsible for a large portion of our city's carbon emissions, which is why we can't afford to delay. Fully electrifying a single house can reduce its carbon emissions by up to 90% depending on how clean the grid is. We are lucky in San Francisco to get most of our energy from carbon-free sources, meaning we get more bang for our buck when we electrify our homes.

While I am in full support of this ordinance, I ask that, to more fully realize the health, climate and economic benefits of electrification and ensure that any exemptions to this important requirement are under legitimately exceptional circumstances, the following changes be made to strengthen the ordinance and implementing regulations:

- 1) eliminate the feasibility exception to the electric-ready requirement;
- 2) create a Clean Energy Buildings Hub that evaluates equity and economic considerations and informs the creation of additional education and technical support resources for affected groups (e.g., small businesses, restaurants, affordable housing, contractors, workforce standards), maximizing opportunities and eliminating barriers to utilization of all-electric new construction to address climate and equity;
- 3) expand and clarify the definition of "Mixed-Fuel Buildings" in the ordinance to include laboratory and industrial buildings, as well as decorative uses of gas;
- 4) provide additional limitations and transparency in the exemption process to ensure any project found exempt for infeasibility is truly in the public interest; and
- 5) eliminate the blanket exemption for commercial kitchens delaying compliance until 2022;

California is burning and our air is unbreathable. There is no more time -- we need bold climate action now. Every building that goes up in San Francisco with gas hookups is just one more building we will have to retrofit for electric heating and appliances later. The prudent thing to do - for our climate, health, and wallets -- is to make sure we aren't digging a deeper hole for ourselves and enact the strongest building electrification ordinance possible. Please support Supervisor Mandelman's ordinance and make San Francisco a climate action leader.

Regards,
Shelley Kuang
235 Paul Ave
San Francisco, CA 94124

From: [Joni](#)
To: [Major, Erica \(BOS\)](#)
Cc: [Walton, Shamann \(BOS\)](#); [Board of Supervisors, \(BOS\)](#); [Preston, Dean \(BOS\)](#); [Peskin, Aaron \(BOS\)](#); [Safai, Ahsha \(BOS\)](#)
Subject: Comment Re: BoS File 200701
Date: Monday, September 21, 2020 12:25:35 PM

This message is from outside the City email system. Do not open links or attachments from untrusted sources.

As a resident of District 10 in San Francisco, I strongly support prohibiting gas in ALL new construction. The air pollution from methane gas adds to the chemical burdens already experienced by so many in my district, especially in Bayview/Hunters Point. And the possibility of leaks and explosions scares me. As a baker, I have personally experienced mini-explosions in two different natural-gas ovens, and it was really scary. I replaced those stoves, but alas, each time with another gas-powered one.

I now use a portable induction electric cooktop, which I love for its safety, efficiency, speed, and coolness (in both senses). But because of the expense of rewiring my 125-year-old house, we cannot begin to afford to replace the gas stove - let alone the gas water heater. So this message is also a plea to look to the future, when we will have to retrofit ALL buildings in the City to get rid of natural gas once and for all: People will need incentives, rebates, education - and this will require massive funding. Yes we are in a health crisis from Covid 19 - but there will never be a vaccine for climate change.

Therefore I also support the creation, now, of a Clean Energy Buildings Hub - as recommended by Earthjustice, the Sierra Club, the San Francisco Climate Emergency Coalition, and other local groups in their letter to the Commission and Board - that evaluates equity and economic considerations and facilitates the creation of additional education and technical support resources for affected groups (e.g., small businesses, restaurants, affordable housing, contractors, workforce standards), maximizing opportunities and eliminating barriers to utilization of all-electric new construction to address climate and equity.

This ordinance is a very important beginning in eliminating emissions from buildings, because obviously building more gas infrastructure will only exacerbate climate change. That's why any exception to the all-electric requirement under this ordinance must:

- be fully, 100% electric-ready, to facilitate future electrification and eliminate the huge expense of a retrofit;
- include in the ordinance's definition of "mixed-fuel buildings" laboratory, industrial, and decorative uses of gas
- be transparent in its process and truly in the public interest.

Thank you for your consideration.

Sincerely,

Joni Eisen
592 Pennsylvania

From: [Mchugh, Eileen \(BOS\)](#)
To: [Major, Erica \(BOS\)](#)
Subject: FW: SUPPORTING Land Use and Transportation Committee Agenda Item #1 Building Code - Mandating New Construction Be All Electric File #200701
Date: Monday, September 21, 2020 4:21:50 PM

From: aeboken <aeboken@gmail.com>
Sent: Saturday, September 19, 2020 5:33 PM
To: BOS-Supervisors <bos-supervisors@sfgov.org>; BOS-Legislative Aides <bos-legislative_aides@sfgov.org>
Subject: SUPPORTING Land Use and Transportation Committee Agenda Item #1 Building Code - Mandating New Construction Be All Electric File #200701

This message is from outside the City email system. Do not open links or attachments from untrusted sources.

TO: Board of Supervisors members

I am strongly supporting changes to the Building Code which would mandate that new construction be all-electric.

This would provide both safety and environmental benefits.

Eileen Boken
Coalition for San Francisco Neighborhoods*

* For identification purposes only.

Sent from my Verizon, Samsung Galaxy smartphone

From: [Hans von Clemm](#)
To: [Major, Erica \(BOS\)](#); [Board of Supervisors, \(BOS\)](#); [Preston, Dean \(BOS\)](#); [Peskin, Aaron \(BOS\)](#); [Safai, Ahsha \(BOS\)](#); [MandelmanStaff, \[BOS\]](#)
Subject: Public Comment Re: BoS File 200701 (Item 1 of 9/21 Land Use)
Date: Monday, September 21, 2020 3:19:18 PM

This message is from outside the City email system. Do not open links or attachments from untrusted sources.

Land Use Committee, Board of Supervisors, and Sup. Mandelman,

I'm a resident of San Francisco writing to strongly support prohibiting gas in new construction. The methane leaks, air pollution, and explosion dangers of natural gas are no longer necessary for the functioning of our homes and businesses. San Francisco can lead the state and the country in building a better future.

In addition to recommending the ordinance, I would also like to ask the Commission to recommend the changes to the ordinance as laid out by Earthjustice, the Sierra Club, the San Francisco Climate Emergency Coalition, and other local groups in their letter to the Commission and Board.

It is important to me that we:

1. Eliminate the feasibility exception to the electric-ready requirement and make fully electric-ready construction a baseline requirement for new construction. We know that the future is electric. Allowing any building to be built that will require massive retrofits in the near future is unacceptable. With full electric readiness, we minimize that retrofit cost.
2. Create a Clean Energy Building Hub through the City and County of San Francisco that provides for the outreach, resources, and education needed to eliminate barriers and maximize opportunity for all-electric new construction to benefit both climate and equity.
3. Expand the ordinance's definition of "mixed-fuel buildings" to include laboratory, industrial, and decorative uses of gas. Gas shouldn't be allowed for upscale decorative uses. It's wrong to harm public health for private enjoyment.
4. Provide additional limitations and transparency in the exemption process to ensure any project found exempt for infeasibility is truly in the public interest. I'm concerned about the news of powerful and connected people being able to get favors from DBI. We need sunshine on the exemption process, and exemptions should only be given in the public interest.
5. Amend section 106A.1.17 to require that the Building Official find "sufficient evidence was submitted to substantiate the infeasibility of an All-Electric Building or Project design without regard to financial, floor-area, or amenity-related loss unless deemed to be in the public welfare." The housing crisis is real. And we need to find ways of fixing it without sacrificing our children's future. The space taken up by a transformer should not be an acceptable reason for

an exemption.

6. Eliminate the blanket exemption for commercial kitchens delaying compliance until 2022. Existing restaurants are not helped by giving builders a pass on making future commercial kitchens all-electric.

Thank you for taking up this important issue and considering the health and safety of our residents and climate.

Hans von Clemm
hansvc95@gmail.com
20 Flint Street
San Francisco, California 94114

From: [Cecilia Palmtag](#)
To: [Major, Erica \(BOS\)](#); [Board of Supervisors, \(BOS\)](#); [Preston, Dean \(BOS\)](#); [Peskin, Aaron \(BOS\)](#); [Safai, Ahsha \(BOS\)](#); [MandelmanStaff, \(BOS\)](#)
Subject: Public Comment Re: BoS File 200701 (Item 1 of 9/21 Land Use)
Date: Monday, September 21, 2020 3:03:53 PM

This message is from outside the City email system. Do not open links or attachments from untrusted sources.

Land Use Committee, Board of Supervisors, and Sup. Mandelman,

I'm a resident of San Francisco writing to strongly support prohibiting gas in new construction. The methane leaks, air pollution, and explosion dangers of natural gas are no longer necessary for the functioning of our homes and businesses. San Francisco can lead the state and the country in building a better future.

In addition to recommending the ordinance, I would also like to ask the Commission to recommend the changes to the ordinance as laid out by Earthjustice, the Sierra Club, the San Francisco Climate Emergency Coalition, and other local groups in their letter to the Commission and Board.

It is important to me that we:

1. Eliminate the feasibility exception to the electric-ready requirement and make fully electric-ready construction a baseline requirement for new construction. We know that the future is electric. Allowing any building to be built that will require massive retrofits in the near future is unacceptable. With full electric readiness, we minimize that retrofit cost.
2. Create a Clean Energy Building Hub through the City and County of San Francisco that provides for the outreach, resources, and education needed to eliminate barriers and maximize opportunity for all-electric new construction to benefit both climate and equity.
3. Expand the ordinance's definition of "mixed-fuel buildings" to include laboratory, industrial, and decorative uses of gas. Gas shouldn't be allowed for upscale decorative uses. It's wrong to harm public health for private enjoyment.
4. Provide additional limitations and transparency in the exemption process to ensure any project found exempt for infeasibility is truly in the public interest. I'm concerned about the news of powerful and connected people being able to get favors from DBI. We need sunshine on the exemption process, and exemptions should only be given in the public interest.
5. Amend section 106A.1.17 to require that the Building Official find "sufficient evidence was submitted to substantiate the infeasibility of an All-Electric Building or Project design without regard to financial, floor-area, or amenity-related loss unless deemed to be in the public welfare." The housing crisis is real. And we need to find ways of fixing it without sacrificing our children's future. The space taken up by a transformer should not be an acceptable reason for

an exemption.

6. Eliminate the blanket exemption for commercial kitchens delaying compliance until 2022. Existing restaurants are not helped by giving builders a pass on making future commercial kitchens all-electric.

Thank you for taking up this important issue and considering the health and safety of our residents and climate.

Cecilia Palmtag
cecilia.palmtag@gmail.com
120 Clinton Park
San Francisco, California 94103

From: [Maura Fallon-McKnight](#)
To: [Major, Erica \(BOS\)](#)
Subject: Support for Proposed Ordinance: Mandating New Construction Be All-Electric
Date: Monday, September 21, 2020 2:59:17 PM

This message is from outside the City email system. Do not open links or attachments from untrusted sources.

Regarding: Building Code - Mandating New Construction Be All-Electric; **Sponsor:** Mandelman

Hello -

I had an opportunity to speak today in support of this ordinance and I may have been cut off before I specifically said that our organization strongly supports this ordinance. My name is Maura McKnight and I am the Executive Director of the Business Council on Climate Change based in San Francisco. <http://www.bc3sfbay.org/>

Our organization strongly supports this proposed ordinance.

Founded in 2007, BC3 is a membership-driven nonprofit of corporate sustainability leaders implementing and championing tangible climate action.

Our members are a major economic engine for the region and employ more than 750,000 people.

This legislation is a bold step on climate and I applaud all of the individuals and groups that have worked on it to date.

Many of our member companies have set carbon neutral and net zero emissions goals that align with the City of SF's bold pledge to zero out emissions by 2050.

Some of our members have even set "carbon negative" targets - meaning they plan to go beyond zeroing out their emissions and invest in new approaches to carbon reduction, capture, and removal technologies

All of us who live in the Bay Area and have just been reminded of the very real impacts of the climate emergency we are facing - with disastrous effects for health during a pandemic. The time to act boldly is now.

Our members are leaders in this space and they have been doing electrification pilot projects both locally in San Francisco and abroad because they know that this is key to meeting our global and local climate goals.

- Natural gas is a fossil fuel super-pollutant that is 86 times more potent than carbon dioxide.

The Business Council on Climate Change strongly supports this proposed legislation.

Thank you.

Maura McKnight
Executive Director
Business Council on Climate Change
Cell 415.350.7652; www.bc3sfbay.org

From: [Dave Rhody](#)
To: [Major, Erica \(BOS\)](#); [Board of Supervisors, \(BOS\)](#); [Preston, Dean \(BOS\)](#); [Peskin, Aaron \(BOS\)](#); [Safai, Ahsha \(BOS\)](#); [MandelmanStaff, \(BOS\)](#); [Mar, Gordon \(BOS\)](#)
Subject: Public Comment Re: BoS File 200701 (Item 1 of 9/21 Land Use)
Date: Monday, September 21, 2020 1:24:41 PM

This message is from outside the City email system. Do not open links or attachments from untrusted sources.

Land Use Committee, Board of Supervisors, and Sup. Mar,

I'm a resident of San Francisco and an Climate Reality Leader. I and my climate colleagues strongly support building decarbonization in SF. Prohibiting gas in new construction is the first step. San Francisco can lead the state and the country in building a better future.

In addition to recommending the ordinance, I would also like to ask the Commission to recommend the changes to the ordinance as laid out by Earthjustice, the Sierra Club, the San Francisco Climate Emergency Coalition, and other local groups in their letter to the Commission and Board.

It is important to me that we:

1. Eliminate the feasibility exception to the electric-ready requirement and make fully electric-ready construction a baseline requirement for new construction. We know that the future is electric. Allowing any building to be built that will require massive retrofits in the near future is unacceptable. With full electric readiness, we minimize that retrofit cost.
2. Create a Clean Energy Building Hub through the City and County of San Francisco that provides for the outreach, resources, and education needed to eliminate barriers and maximize opportunity for all-electric new construction to benefit both climate and equity.
3. Expand the ordinance's definition of "mixed-fuel buildings" to include laboratory, industrial, and decorative uses of gas. Gas shouldn't be allowed for upscale decorative uses. It's wrong to harm public health for private enjoyment.
4. Provide additional limitations and transparency in the exemption process to ensure any project found exempt for infeasibility is truly in the public interest. I'm concerned about the news of powerful and connected people being able to get favors from DBI. We need sunshine on the exemption process, and exemptions should only be given in the public interest.
5. Amend section 106A.1.17 to require that the Building Official find "sufficient evidence was submitted to substantiate the infeasibility of an All-Electric Building or Project design without regard to financial, floor-area, or amenity-related loss unless deemed to be in the public welfare." The housing crisis is real. And we need to find ways of fixing it without sacrificing our children's future. The space taken up by a transformer should not be an acceptable reason for an exemption.

6. Eliminate the blanket exemption for commercial kitchens delaying compliance until 2022. Existing restaurants are not helped by giving builders a pass on making future commercial kitchens all-electric.

Thank you.

Dave Rhody
dave@rhodyco.com
1594 45th Ave.
San Francisco, California 94122

From: [Cate Levey](#)
To: [Major, Erica \(BOS\)](#); [Board of Supervisors, \(BOS\)](#); [Preston, Dean \(BOS\)](#); [Peskin, Aaron \(BOS\)](#); [Safai, Ahsha \(BOS\)](#); [MandelmanStaff, \(BOS\)](#); [Ronen, Hillary](#)
Subject: Public Comment Re: BoS File 200701 (Item 1 of 9/21 Land Use)
Date: Monday, September 21, 2020 11:03:58 AM

This message is from outside the City email system. Do not open links or attachments from untrusted sources.

Land Use Committee, Board of Supervisors, and Sup. Ronen,

I'm a resident of San Francisco writing to strongly support prohibiting gas in new construction. The methane leaks, air pollution, and explosion dangers of natural gas are no longer necessary for the functioning of our homes and businesses. San Francisco can lead the state and the country in building a better future.

In addition to recommending the ordinance, I would also like to ask the Commission to recommend the changes to the ordinance as laid out by Earthjustice, the Sierra Club, the San Francisco Climate Emergency Coalition, and other local groups in their letter to the Commission and Board.

It is important to me that we:

1. Eliminate the feasibility exception to the electric-ready requirement and make fully electric-ready construction a baseline requirement for new construction. We know that the future is electric. Allowing any building to be built that will require massive retrofits in the near future is unacceptable. With full electric readiness, we minimize that retrofit cost.
2. Create a Clean Energy Building Hub through the City and County of San Francisco that provides for the outreach, resources, and education needed to eliminate barriers and maximize opportunity for all-electric new construction to benefit both climate and equity.
3. Expand the ordinance's definition of "mixed-fuel buildings" to include laboratory, industrial, and decorative uses of gas. Gas shouldn't be allowed for upscale decorative uses. It's wrong to harm public health for private enjoyment.
4. Provide additional limitations and transparency in the exemption process to ensure any project found exempt for infeasibility is truly in the public interest. I'm concerned about the news of powerful and connected people being able to get favors from DBI. We need sunshine on the exemption process, and exemptions should only be given in the public interest.
5. Amend section 106A.1.17 to require that the Building Official find "sufficient evidence was submitted to substantiate the infeasibility of an All-Electric Building or Project design without regard to financial, floor-area, or amenity-related loss unless deemed to be in the public welfare." The housing crisis is real. And we need to find ways of fixing it without sacrificing our children's future. The space taken up by a transformer should not be an acceptable reason for

an exemption.

6. Eliminate the blanket exemption for commercial kitchens delaying compliance until 2022. Existing restaurants are not helped by giving builders a pass on making future commercial kitchens all-electric.

Thank you for taking up this important issue and considering the health and safety of our residents and climate.

Cate Levey
leveycat@gmail.com
1040 Hampshire St
San Francisco , California 94110

From: [SF Climate Emergency Coalition](#)
To: [Peskin, Aaron \(BOS\)](#); [Safai, Ahsha \(BOS\)](#); [Preston, Dean \(BOS\)](#); [MandelmanStaff, \[BOS\]](#); [Major, Erica \(BOS\)](#)
Cc: [Raphael, Deborah \(ENV\)](#); [Board of Supervisors, \(BOS\)](#); [Bintliff, Jacob \(BOS\)](#); [Hepner, Lee \(BOS\)](#); [Smeallie, Kyle \(BOS\)](#); [Sandoval, Suhagey \(BOS\)](#); [Comerford, Cyndy \(ENV\)](#)
Subject: Technical Feasibility of All-Electric Multi-Unit High Rise Buildings (Re: BoS File 200701)
Date: Wednesday, September 23, 2020 11:47:08 AM
Attachments: [Heat pump Installation drawing.pdf](#)
[14_Engineering-Bulletin_HPWH-Piping-Arrangements.pdf](#)

This message is from outside the City email system. Do not open links or attachments from untrusted sources.

To: Members of the Land Use Committee, Supervisor Mandelman, and the Department of the Environment

At the September 21 Land Use hearing on the all-electric new construction legislation, Supervisor Safai asked if multi-unit high-rise could be supported. The answer, as stated by both Supervisor Mandelman and Director Raphael, is an unequivocal “YES”

However, there is a significant difference in the type of systems used for high-rises from those used in 2 to 4 story buildings. There are many off-the shelf systems designed for residential units in a 2-4 story building, as this is a common residential building. However, for large high-rises these standard components are not suitable, and so a custom designed system is required. This is also the case for a conventional gas fired system in high-rises. The water distribution system design in high-rises is complex no matter how the water is heated.

Although at the moment fewer companies support this heat pump market segment, Colmac is a leader in the field (<https://colmacwaterheat.com/>). Their modular units can be combined in many ways to support a building of any size, while occupying a relatively small footprint in the building.

A local example is Casa Adelante (2060 Folsom St, San Francisco, CCDC & MEDA) has just started leasing, providing affordable housing and transition age youth housing with ground floor retail space on the first floor. It has 127 units in a 9 story 100% electric design building, which uses Colmac air source heat pumps for hot water.

Colmac has an engineering bulletin (attached) with guidelines for installation in much taller buildings. An example cited in support of the Berkeley ordinance is the 5th & Lenora project in Seattle. This all-electric 44-story, 450+ units building (<https://cao-94612.s3.amazonaws.com/documents/Scott-Shell-Oakland-Berkeley-All-electric-multi-family-buildings-6-13-19.pdf>, pp20, 22) is in the final pre construction phase.

Attached are 2 pdfs with relevant information from Colmac, as well as a link to an overview of building electrification:

- “HeatPump Installation Drawing”, a set of three Colmac drawings showing how several modules can be combined in a relatively small floor area.
- A Colmac engineering bulletin showing various installation schematics. In particular, Figure 8 (p.13) shows a recommended configuration for a 30-story residential high-rise

Additionally, there is “A Zero Emissions All-Electric Multifamily Construction Guide” from

Redwood Energy, a world leader in affordable all -electric construction working with the California Building Decarbonization Coalition. This is an overview of all electric construction, with information on large residential projects. This file is too large for e-mail but can be found at <http://www.buildingdecarb.org/store/p7/ZEB-Multifamily-Guide.html>

Should you want more technical details on the heat pump system capabilities, you can contact Erik Parsley at Colmac (erik.parsley@colmacwaterheat.com, 800-926-5622), or any of the other Colmac engineers.

Of course, we would also be happy to discuss this further. Feel free to reach out if you have further questions

Best,

SF Climate Emergency Coalition



[Website](#) | [Twitter](#)

Unit Specifications:

- Compressor: (1) Scroll, Copeland or Equivalent
- Condensers: (1) Brazed Plate
- Evaporators: (1) Brazed Plate
- Potable Water Pump: (1) Standard, 150 Max Working Pressure
- Source Water Pump: Provided by Others; 165 PSI Max Working Pressure
- Maximum Source Flow Rate: 150 GPM
- Control: Microprocessor (PLC)
- Frame: 304 SST
- Refrigerant: 134a

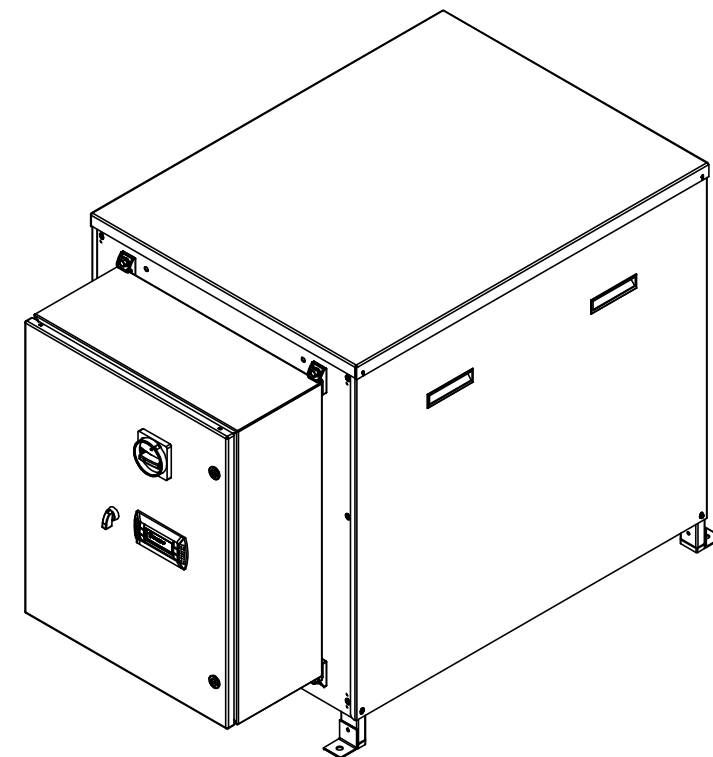
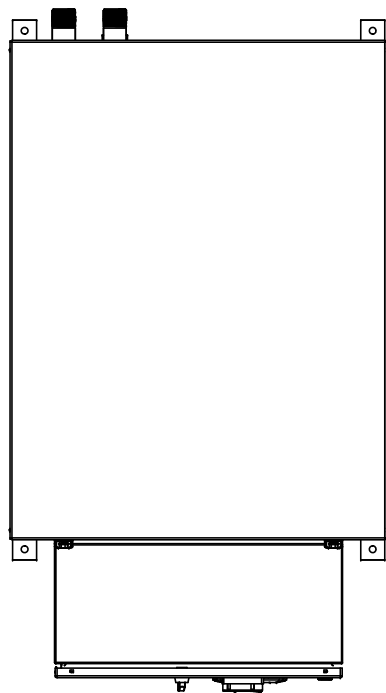

RIGHT SIDE VIEW

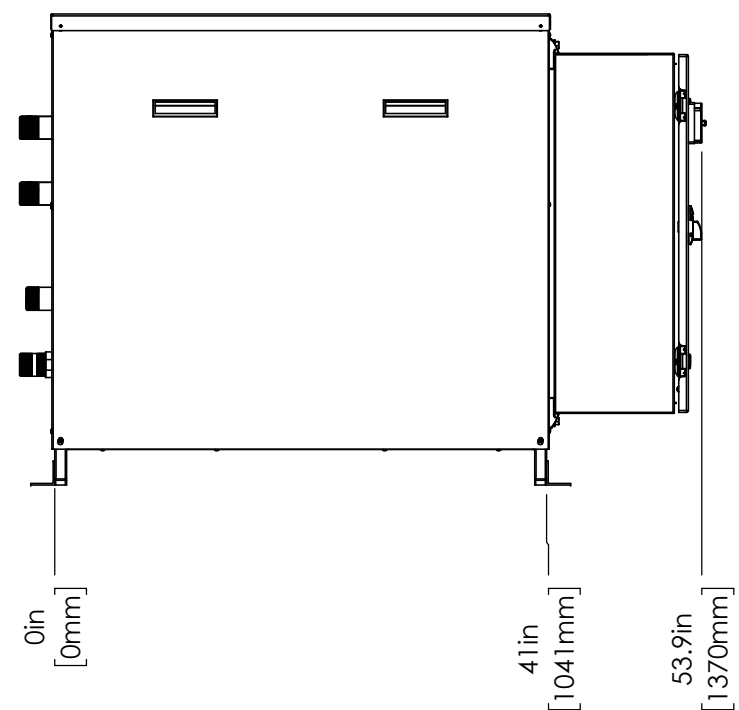

REAR VIEW

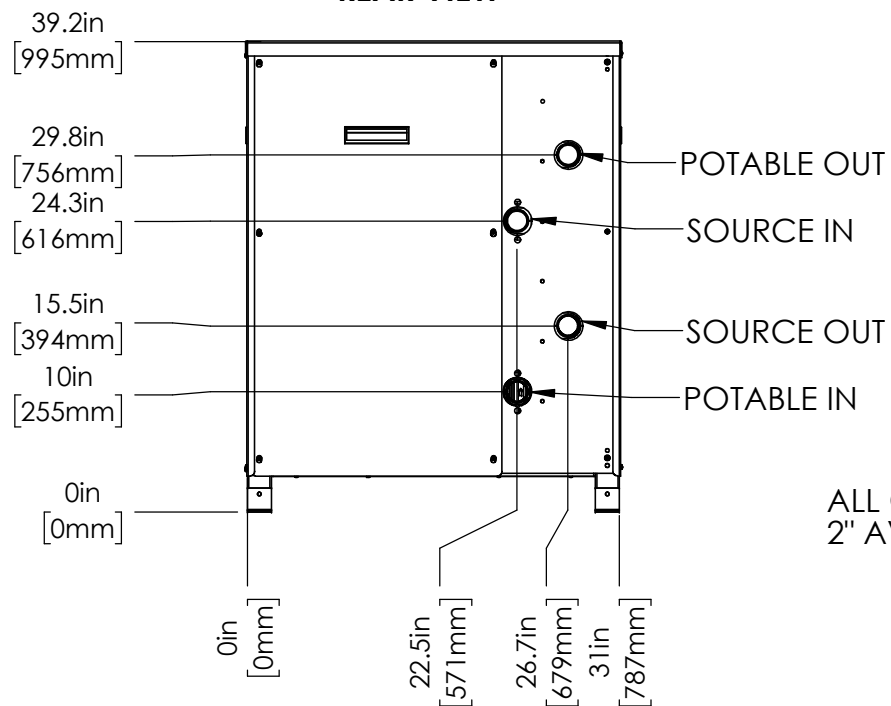

ALL CONNECTIONS ARE 1.5" MNPT.
2" AVAILABLE BY REQUEST.

UNLESS OTHERWISE SPECIFIED: DIMENSIONS ARE IN INCHES TOLERANCES: FRACTIONAL ±1/16 ANGULAR: MACH ±1° BEND ±1° TWO PLACE DECIMAL ±0.03 THREE PLACE DECIMAL ±0.031		COLMAC INDUSTRIES 401 N. Lincoln, Colville, Washington 99114 (509)684-4505	
DRAWN BY KLR		DATE 5/12/2017	
ENGINEER		DATE	
SOLIDWORKS		AUTOCAD	
DO NOT SCALE DRAWING		SCALE: 1:16	UNIT WT.
REV. No. SHT. No.		REV STATUS OF SHEET	
TITLE: GENERAL SUBMITTAL CxW-10 THRU CxW-30		SIZE B	DWG. NO. 1010CXW-0001
PROPRIETARY AND CONFIDENTIAL		SHEET 1 OF 3	

PROPRIETARY AND CONFIDENTIAL
THE INFORMATION CONTAINED IN THIS DRAWING IS THE SOLE PROPERTY OF COLMAC INDUSTRIES. ANY REPRODUCTION IN PART OR AS A WHOLE WITHOUT THE WRITTEN PERMISSION OF COLMAC INDUSTRIES IS PROHIBITED.

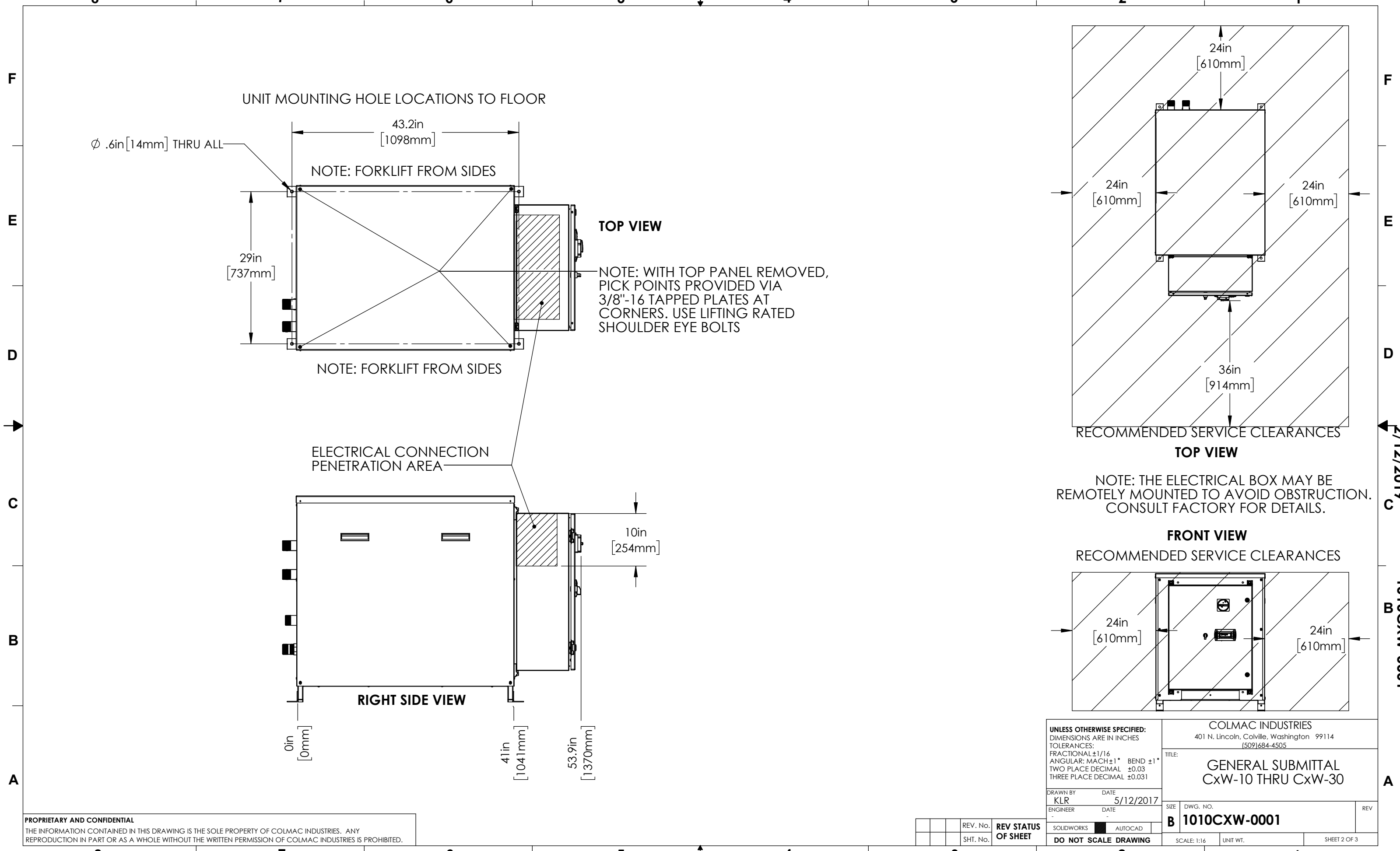

PROPRIETARY AND CONFIDENTIAL
 THE INFORMATION CONTAINED IN THIS DRAWING IS THE SOLE PROPERTY OF COLMAC INDUSTRIES. ANY REPRODUCTION IN PART OR AS A WHOLE WITHOUT THE WRITTEN PERMISSION OF COLMAC INDUSTRIES IS PROHIBITED.

REV. No.	REV STATUS OF SHEET	ENGINEER	DATE	SCALE: 1:16	UNIT WT.	SHEET 2 OF 3
SHT. No.		SOLIDWORKS	5/12/2017			

UNLESS OTHERWISE SPECIFIED:
 DIMENSIONS ARE IN INCHES
 TOLERANCES:
 FRACTIONAL: ±1/16
 ANGULAR: MACH ±1° BEND ±1°
 TWO PLACE DECIMAL ±0.03
 THREE PLACE DECIMAL ±0.031

COLMAC INDUSTRIES
 401 N. Lincoln, Colville, Washington 99114
 (509)684-4505

TITLE:
GENERAL SUBMITTAL
CxW-10 THRU CxW-30

DRAWN BY: KLR DATE: 5/12/2017
 ENGINEER: DATE:

SIZE: DWG. NO. REV
B 1010CXW-0001

2/12/2019

1010CXW-0001

NOTE: UNITS MAY BE STACKED UP TO TWO HIGH (STACKING IS NOT SEISMICALLY RATED) UNITS MAY ALSO BE INSTALLED SIDE BY SIDE WITH 1" GAP SO LONG AS PROVISION IS MADE FOR SERVICING (FOR EXAMPLE, BY PULLING UNITS FORWARD, OR BY MOVING UNITS TO ONE SIDE); OTHERWISE, A MINIMUM OF 24" IS RECOMMENDED BETWEEN UNITS.

EXAMPLE CONFIGURATION: 2 X N SERVICE CLEARANCE PROVIDED BY MOVING STACKED UNIT PAIR FORWARD

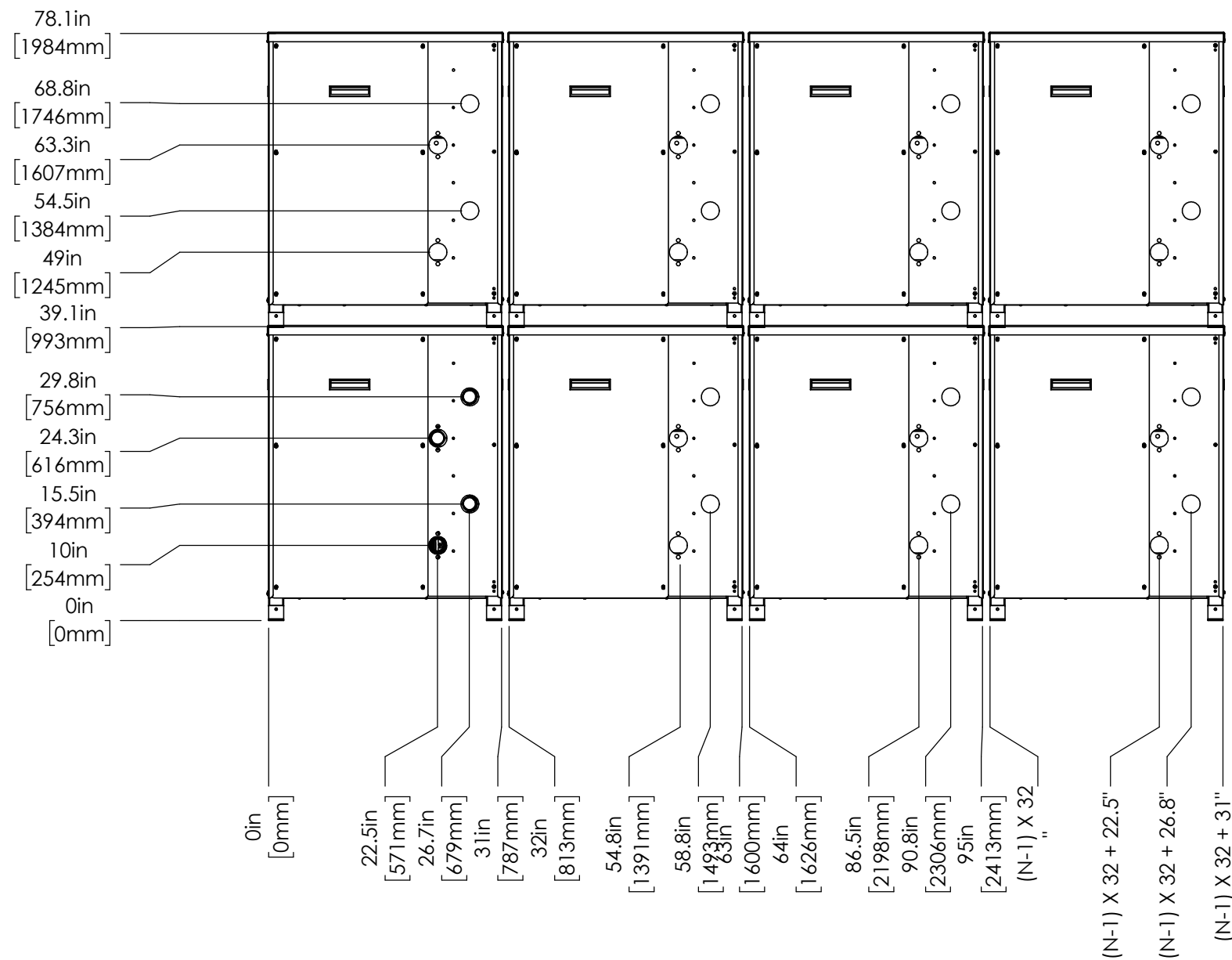

EXAMPLE CONFIGURATION: 1 X 2 WITH SERVICE CLEARANCE

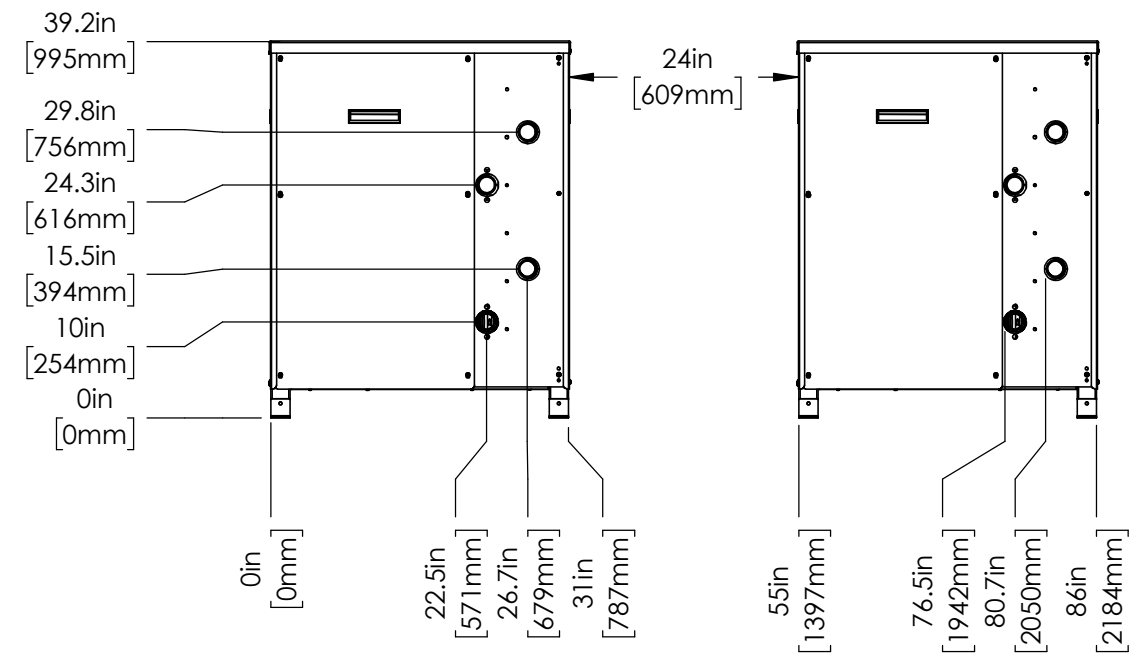

EXAMPLE CONFIGURATION: 1 X 3

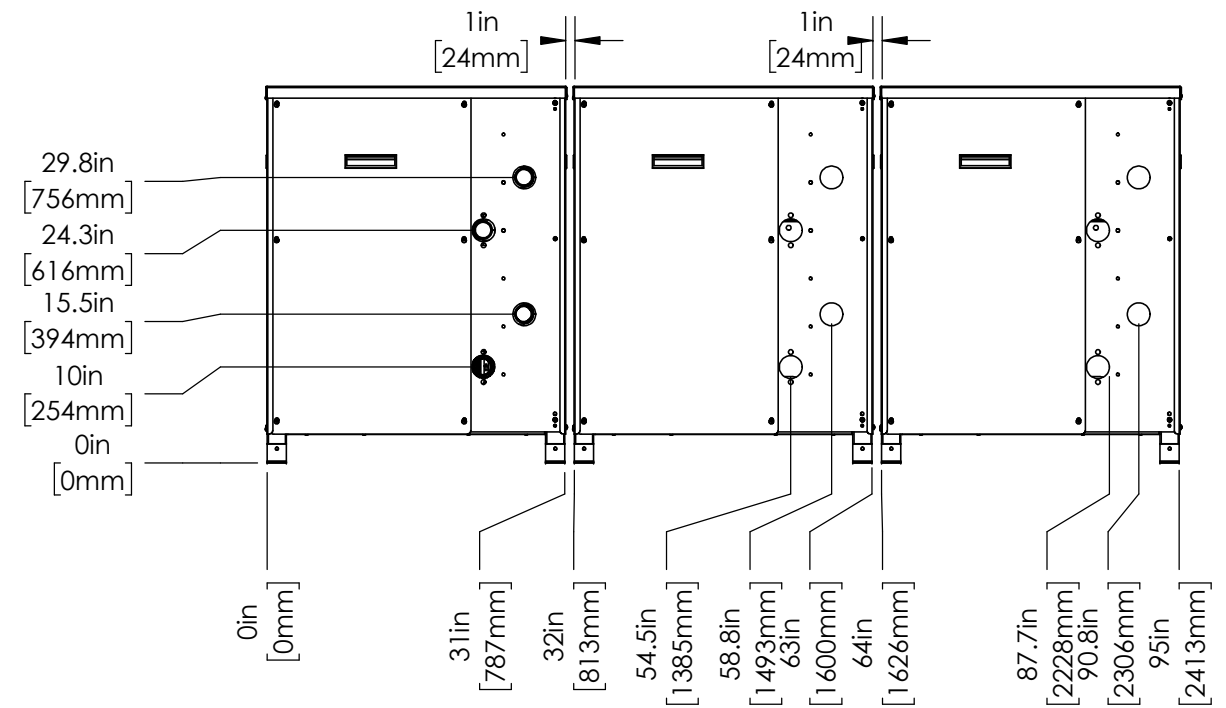

PROPRIETARY AND CONFIDENTIAL THE INFORMATION CONTAINED IN THIS DRAWING IS THE SOLE PROPERTY OF COLMAC INDUSTRIES. ANY REPRODUCTION IN PART OR AS A WHOLE WITHOUT THE WRITTEN PERMISSION OF COLMAC INDUSTRIES IS PROHIBITED.

Table with technical specifications and title block information including COLMAC INDUSTRIES, GENERAL SUBMITTAL CxW-10 THRU CxW-30, and drawing details.

Table with revision and status information including REV. No., REV STATUS OF SHEET, and SHEET No.



Engineering Bulletin
940126-0003
Rev B

Piping Arrangements for
Heat Pump Water Heating



Contents

1. INTRODUCTION	0
2. WATER PIPING	0
3. HEAT PUMP WATER HEATER PIPING	1
4. RINGMAIN (RECIRCULATING LOOP) PIPING.....	2
5. HOT WATER SUPPLY RISER PIPING	4
6. PIPING DIAGRAMS	5

1. INTRODUCTION

- 1.1. Sanitary (Domestic) hot water can be effectively and efficiently heated using Colmac Heat Pump Water Heaters (HPWH). Because they use low grade (low temperature) heat as the energy source, Colmac Heat Pump Water Heaters can heat sanitary water and simultaneously cool air (or water) with as little as 1/10th the energy input of conventional boilers and chillers. Correctly piping the Colmac Heat Pump Water Heater to the building hot water system is critical to proper and successful operation. Incorrect piping and/or storage tank selection can result in inadequate hot water temperatures and/or heating capacity of the system - even though the heat pumps may be sized with more than enough heating capacity!

2. WATER PIPING

- 2.1. General: For proper heat pump operation it is important to plumb the water piping and storage tanks as indicated in the appropriate piping diagrams. Several common piping diagrams are included at the end of this section
 - 2.1.1. All piping diagrams show nonvented pressurized systems. Vented nonpressurized systems are not recommended.
 - 2.1.2. System piping should be plumbed and storage tanks installed in accordance with all local and national codes that apply.
 - 2.1.3. A Pressure Temperature (P-T) type relief valve is required on all nonvented pressurized tanks, as shown in the piping diagrams.
 - 2.2. Insulation: It is highly recommended that all hot water piping and storage tanks be insulated for energy efficiency.
 - 2.2.1. Outdoor applications: Fiberglass with aluminum sheathing is preferred for piping and tanks (also sprayed foam for tanks).
 - 2.2.2. Indoor applications: Fiberglass with paper sheathing is preferred for piping and tanks (also sprayed foam for tanks). Closed cell foam is acceptable for piping and tanks, where permitted.
 - 2.3. Pipe Sizing: Colmac heat pump water heaters are equipped with internal hot water circulating pumps. These internal circulating pumps are capable of maintaining the minimum required water flowrate through the heat pump with external pressure drops up to 4.1 ft H₂O (12 kPa) for 50 Hz models and up to 7 ft H₂O (21 kPa) for 60 Hz models. Pressure drop through the hot water piping connecting the heat pump(s) to storage tanks must be carefully calculated and limited to these maximum values. If higher pressure drops are unavoidable then a pressure booster circulating pump must be installed in the hot water piping to compensate and maintain sufficient water flow through the heat pump(s).
 - 2.4. Existing Water Storage Tanks: The use of existing resistance heat water tanks is permitted when the tank volume is suitable for the job application.
 - 2.4.1. WARNING. The use of existing gas water heaters and boiler as storage tanks is not recommended due to high standby losses.
 - 2.4.2. The use of existing water storage tanks is permitted only if measures are taken to remove all accumulated scale deposits in the tank prior to starting heat pump system.
-

2.4.3. WARNING. Using existing water tanks without proper cleaning can result in fouling of the internal heat pump water piping and may cause damage to the water circulating pump.

2.5. Booster Pump:

2.5.1. In piping systems where the heat pump is located far away from the storage tanks, it may be necessary to install a booster pump to maintain the minimum required flow rate. See the pump manufacturers design data for the required flow rate and pressure. Reference section 7.3 above.

2.6. Net Positive Suction Head (NPSH):

2.6.1. This term is defined as the water pressure required at the inlet of the pump to cause water to flow (and prevent cavitation). NPSH can be calculated as follows:

- $NPSH = \text{Barometric Pressure} + \text{Static Pressure on Suction} - \text{Friction losses in Suction Piping} - \text{Vapor Pressure of Water}$

2.6.2. Minimum NPSH required for the circulating pump to operate without cavitating is 9.5 psi (65 kPa).

2.6.3. Normally with non-vented pressurized hot water systems, NPSH is well above the 9.5 psi required by the circulating pump. NPSH becomes critical when the hot water system is vented and non-pressurized. For a vented system, it is important to locate the heat pump below the storage tank. This will: a) Keep the NPSH above the minimum required 9.5 psi, and b) prevent a loss of prime in the pump (the circulating pump is not self-priming).

3. HEAT PUMP WATER HEATER PIPING

3.1. General

3.1.1. For most sanitary water heating applications, hot water usage varies from hour to hour and follows a "load profile" over the course of the day. Normally in occupied buildings (hotels, apartments, hospitals, restaurants, etc), peaks in hot water usage occur in the morning hours and again in the evening.

3.1.2. Heating and storing hot water during off-peak periods allows the heat pump water heater size (and first cost) to be reduced.

3.1.3. Control of the heat pump water heater(s) is by a simple aquastat with the sensor located as shown in the drawings below. The sensor is located below the centerline of the cold tank.

3.1.4. Storage efficiency of the tanks is maximized when they are piped in series as shown in the diagrams below (See Colmac Document 930091-0053)

3.1.5. It is important to insure and confirm that there is an adequate source of heat for the heat pump year around, especially during winter months when air temperatures and air-conditioning loads are lowest. In the event that sufficient waste heat or air-conditioning loads are not available during winter months, backup or auxiliary water heating must be considered.

3.2. Colmac HPA Air-Source HPWH

3.2.1. Colmac HPA air-source heat pump water heaters can be used effectively when the building has a central hot water system but no central air-conditioning system, or limited access to the central air-conditioning system.

3.2.2. Piping connecting HPA heat pumps to storage tanks is as shown in the diagrams below. Only hot water piping is needed with air-source heat pump water heaters.

3.2.3. Strainers should be added to the water inlet to filter out sediment before it reaches the HPA.

3.3. Colmac HPW Water-Source HPWH

3.3.1. Colmac HPW water-source heat pump water heaters can be used effectively when the building has both central water heating and central air-conditioning.

3.3.2. Piping connecting HPW heat pumps to storage tanks is identical to HPA heat pumps and is as shown in the diagrams below.

3.3.3. Source water may be taken either from the condenser water loop or from the return chilled water line.

3.3.4. Energy efficiency and COP of the heat pump will be highest when condenser water is used as the heat source. However, care must be taken not to overcool the condenser water during periods of low air-conditioning loads. Overcooling the condenser water loop may result in problems with chiller operation (i.e. on startup).

3.3.5. Colmac HPW heat pump water heaters are provided with source water circulating pumps, so not external pumps are needed.

3.3.6. Source water piping consists of a simple tie-in to and from the chilled water return main, or to and from the condenser water supply main. In either case it is important to confirm that the flowrate in the source water main (return chilled water or condenser water) exceeds the flowrate circulated through the Colmac HPW unit.

3.3.7. Strainers should be added to the Potable and Source water inlets to filter out sediment before it reaches the HPW.

3.4. HPA/HPW Sequence of Operation

3.4.1. The HPA or HPW heat pumps are simply cycled on and off by an aquastat with its sensor mounted in the first of the storage tanks (the "cold tank"). The aquastat sensor should be located below the centerline of the cold tank as shown in the diagrams below.

3.4.2. When multiple HPA or HPW heat pumps are used with a common storage tank(s), a staged aquastat may be used to effectively vary the heating capacity of the system.

4. RINGMAIN (RECIRCULATING LOOP) PIPING

4.1. General

4.1.1. Colmac has developed the HRH Heat Recovery Ringmain Heater and the RH Ringmain Heater specifically to manage ringmain flow and heating to maintain 100% safe sanitary water temperature at set point at all times.

- 4.1.2. The Colmac HRH Heat Recovery Ringmain Heater is a heat pump water heater designed specifically to recover waste heat either from the building air conditioning system (returned chilled water or condenser water), or from a source of warm humid air, while reheating the sanitary water in the ringmain to maintain safe setpoint temperature. The HRH15W water-source model incorporates both source water and sanitary hot water circulating pumps to simplify installation. The HRH15A air-source model produces cool dehumidified air which can be ducted directly to provide spot cooling.
- 4.1.3. The Colmac model RH15E Ringmain Heater uses self-regulating electric resistance elements to heat the ringmain loop water to maintain the sanitary water setpoint temperature while providing loop water circulation.
- 4.1.4. The sanitary hot water pump in both the HRH and RH units is designed to circulate the ringmain water and eliminates the need for a separate ringmain circulating pump.
- 4.1.5. The HRH and RH units are sized to provide enough make-up heating and sanitary hot water circulation for typical ringmain loops handling 6 to 10 floors, depending on loop configuration, water and ambient temperatures, and thickness of loop pipe insulation.
- 4.2. HRH Sequence of Operation
- 4.2.1. The HRH unit controls are self-contained, simple, and automatic. Whenever power is applied to the HRH unit, the hot water circulating pump is powered on and continuously circulates sanitary hot water through the ringmain.
- 4.2.2. Temperature of the ringmain return hot water entering the HRH is monitored by a temperature sensor mounted internally in the unit. Whenever this temperature falls below an adjustable setpoint temperature (minus differential), the unit compressor and source water circulating pump start and continue to operate until the ringmain return water temperature reaches setpoint, at which point the HRH compressor and source water circulating pump then cycle off. Safe sanitary water temperature in the ringmain is thus maintained at all times.
- 4.3. HRH Installation
- 4.3.1. The HRH15W water-source unit has been designed with small footprint dimensions to allow installation in mechanical spaces with limited floor space.
- 4.3.2. The most convenient location for the HRH15W water-source unit is in the mechanical space close to the building pipe well. This allows the unit to be easily piped to the source water piping (either the return chilled water riser or the condenser water riser). The unit is designed for installation against a wall or in a corner of the mechanical room with easy access to service the electrical and mechanical components.
- 4.3.3. The HRH15A air-source unit has been designed with low profile (vertical) dimensions to allow installation in overhead mechanical spaces and false ceilings to conserve floor space. The centrifugal fan allows the cooled air to be ducted to provide spot cooling or augmentation to the building air conditioning system.
- 4.4. RH Sequence of Operation

- 4.4.1. The model RH15E controls are self-contained, simple, and automatic. Whenever power is applied to the RH unit, the hot water circulating pump is powered on and continuously circulates sanitary hot water through the ringmain.
- 4.4.2. Temperature of the ringmain return hot water entering the RH unit is monitored by a temperature sensor mounted internally in the unit. Whenever this temperature falls below an adjustable setpoint temperature (minus differential), the unit electric resistance heating elements cycle on and continue to operate until the ringmain return water temperature reaches setpoint, at which point the RH elements cycle off. Safe sanitary water temperature in the ringmain is thus maintained at all times.
- 4.5. RH Installation
- 4.5.1. The RH15E unit has been designed with small footprint dimensions to allow installation in mechanical spaces with limited floor space.
- 4.5.2. The most convenient location for the RH15E unit is in the mechanical space close to the building pipe well. This allows the unit to be easily piped to the ringmain piping. The unit is designed for installation against a wall or in a corner of the mechanical room with easy access to service the electrical and mechanical components.

5. HOT WATER SUPPLY RISER PIPING

5.1. General

- 5.1.1. In tall buildings with multiple ringmain loops (i.e. more than 8-10 stories) a hot water supply riser is needed to supply the multiple ringmains. Typically the highest ringmain is supplied by a booster pump to provide adequate water pressure to the fixtures on the top floor. Each of the lower ringmains is then supplied with hot water via the hot water supply riser pipe through a PRV (Pressure Reducing Valve) set to match the cold water pressure (also set through a PRV for the same floors supplied by the hot water ringmain).
- 5.1.2. NOTE: Colmac recommends that both cold water storage as well as sanitary hot equipment and storage be located at the top of each zone in the building. This is referred to as "top feed". This arrangement insures that cold water and sanitary water pressures are easily and precisely balanced for each floor.
- 5.1.3. Just as each ringmain loop requires makeup heating to maintain safe water temperature, the hot water supply riser requires makeup heating and recirculating flow. Since the hot water supply riser is separated from the ringmain loops by PRVs it must be piped with its own Colmac HRH or RH unit and a return riser pipe. Recommended piping arrangement is shown below.

6. PIPING DIAGRAMS

6.1. Ringmain loop flow must be prevented from circulating directly through the hot water storage tanks used to store the hot water for the fixtures. Each ringmain loop as well as the hot water supply riser must be circulated and heated separately by its own Colmac HRH or RH unit (described above). This proprietary Colmac method of piping storage tank heat pumps and ringmain heating units separately results in a sanitary hot water system having the following operating characteristics and benefits:

- Lowest first cost,
- Lowest operating cost,
- Lowest life cycle cost,
- 100% health and safety for sanitary hot water,
- Optimized thermal management of hot water ringmains and supply risers,
- Optimized ratio of hot water storage volume to heat pump heating capacity,
- Smallest water heating carbon footprint (highest Carbon Reduction Coefficient – CRC).

Tanks in series with HRH water heating for recirculation loop line losses.

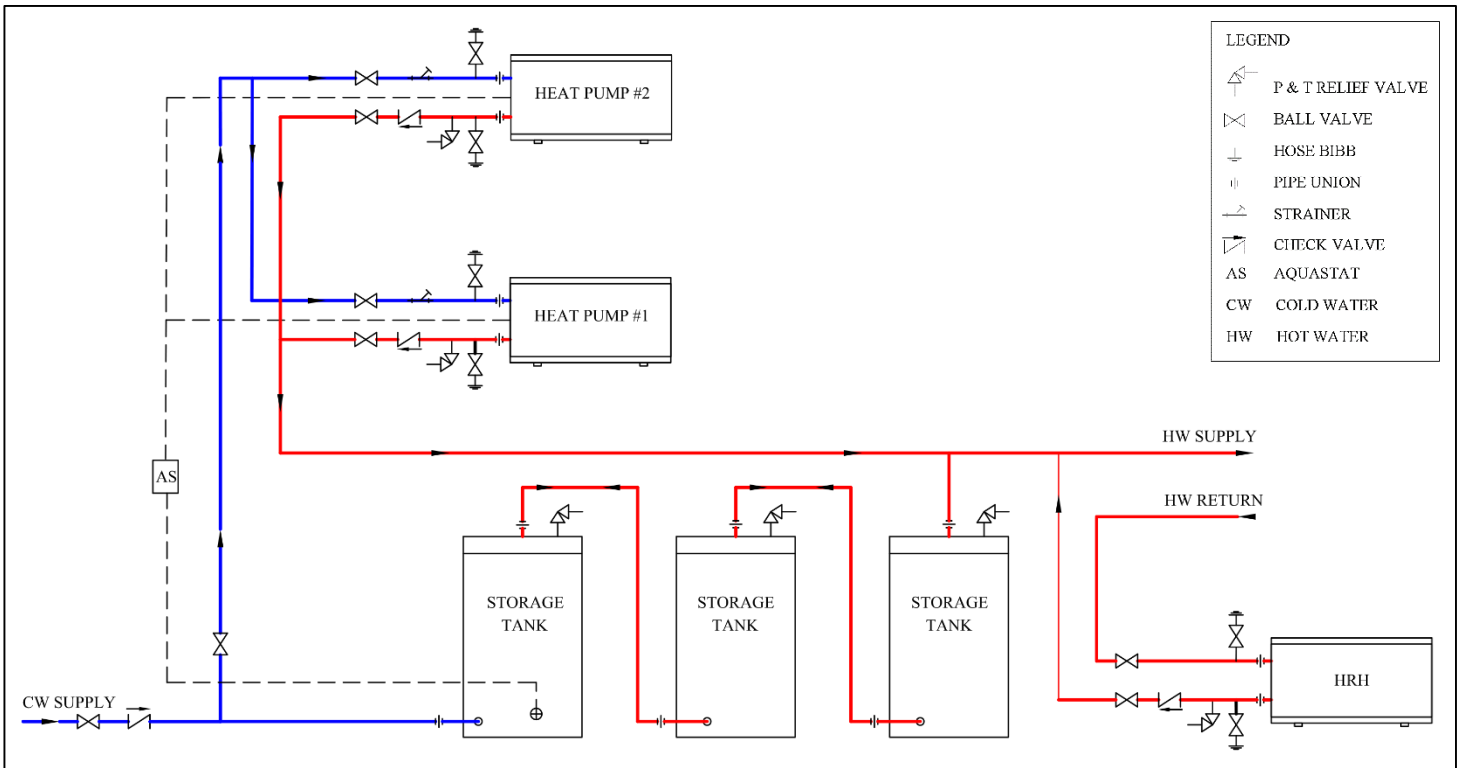

Figure 1

Tanks in series with electric resistance water heating for recirculation loop line losses.

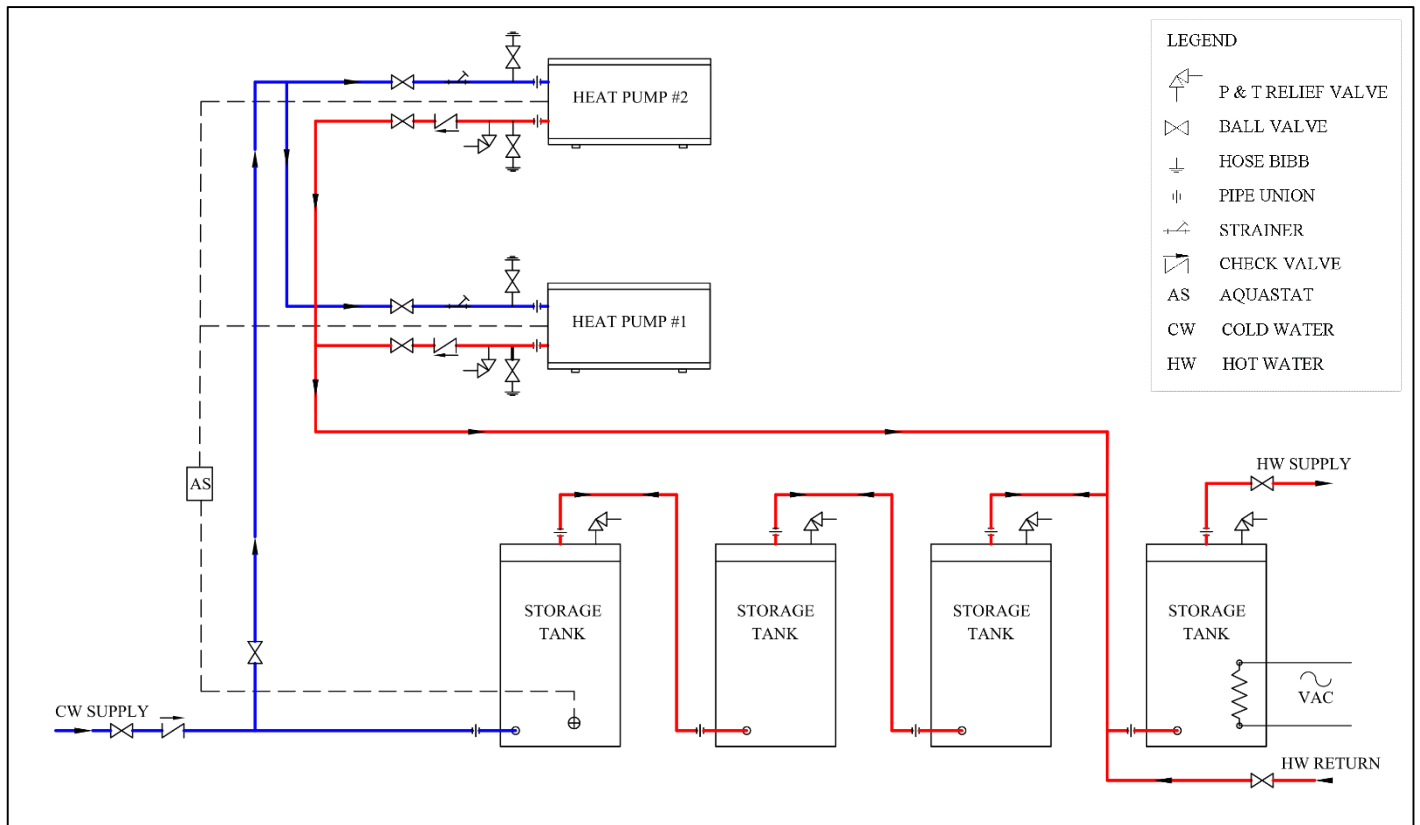

Figure 2

Storage tanks in series, dual aquastat, coldwater storage tank, heated building return

Aquastat setpoints

Start Setpoint: 80°F (Start call for heat at 80°F)

Stop Setpoint: 110°F (End call for heat at 110°F)

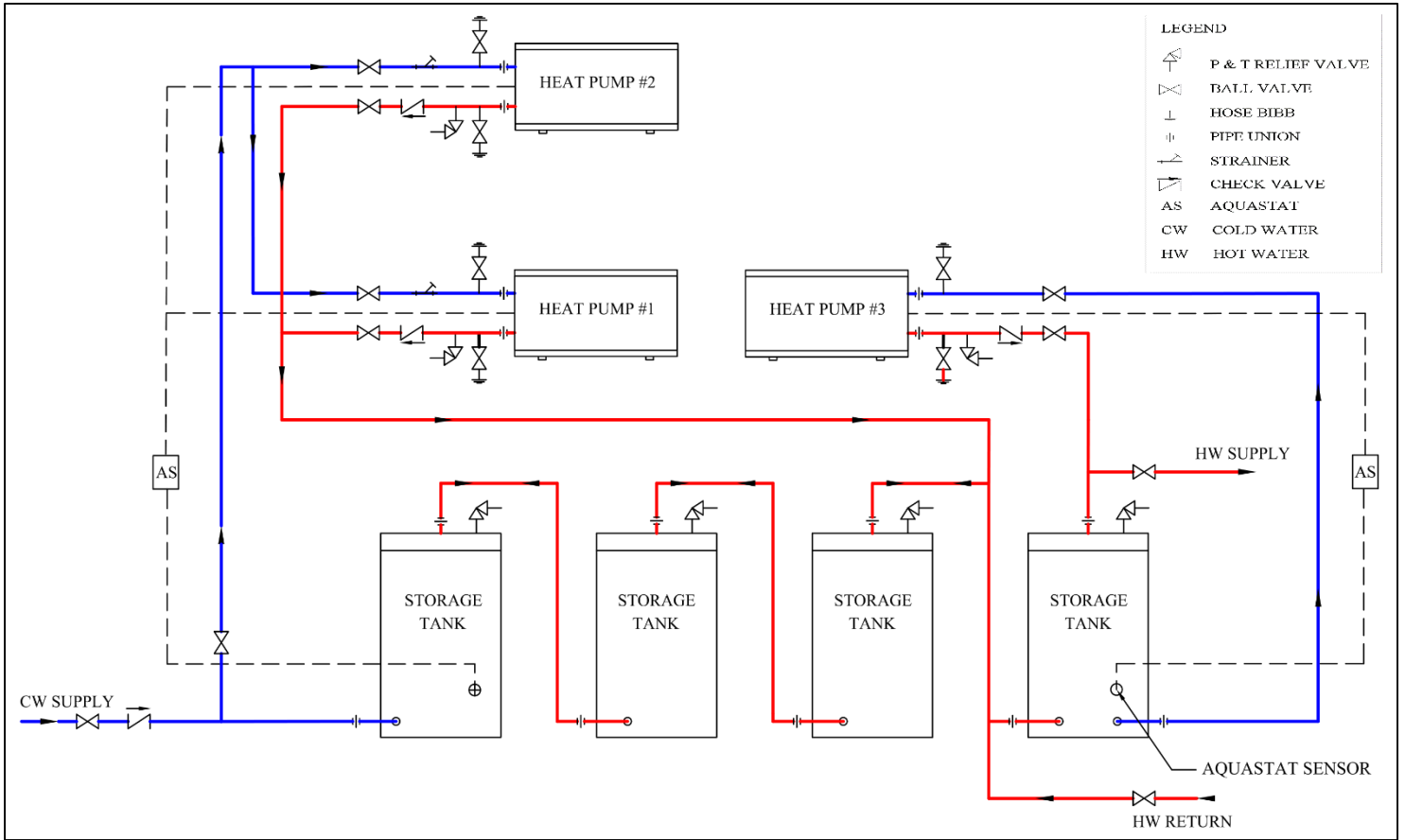

Figure 3

Storage tanks in series, dual aquastat, heated building return

Aquastat setpoints

Start Setpoint: 80°F (Start call for heat at 80°F)

Stop Setpoint: 110°F (End call for heat at 110°F)

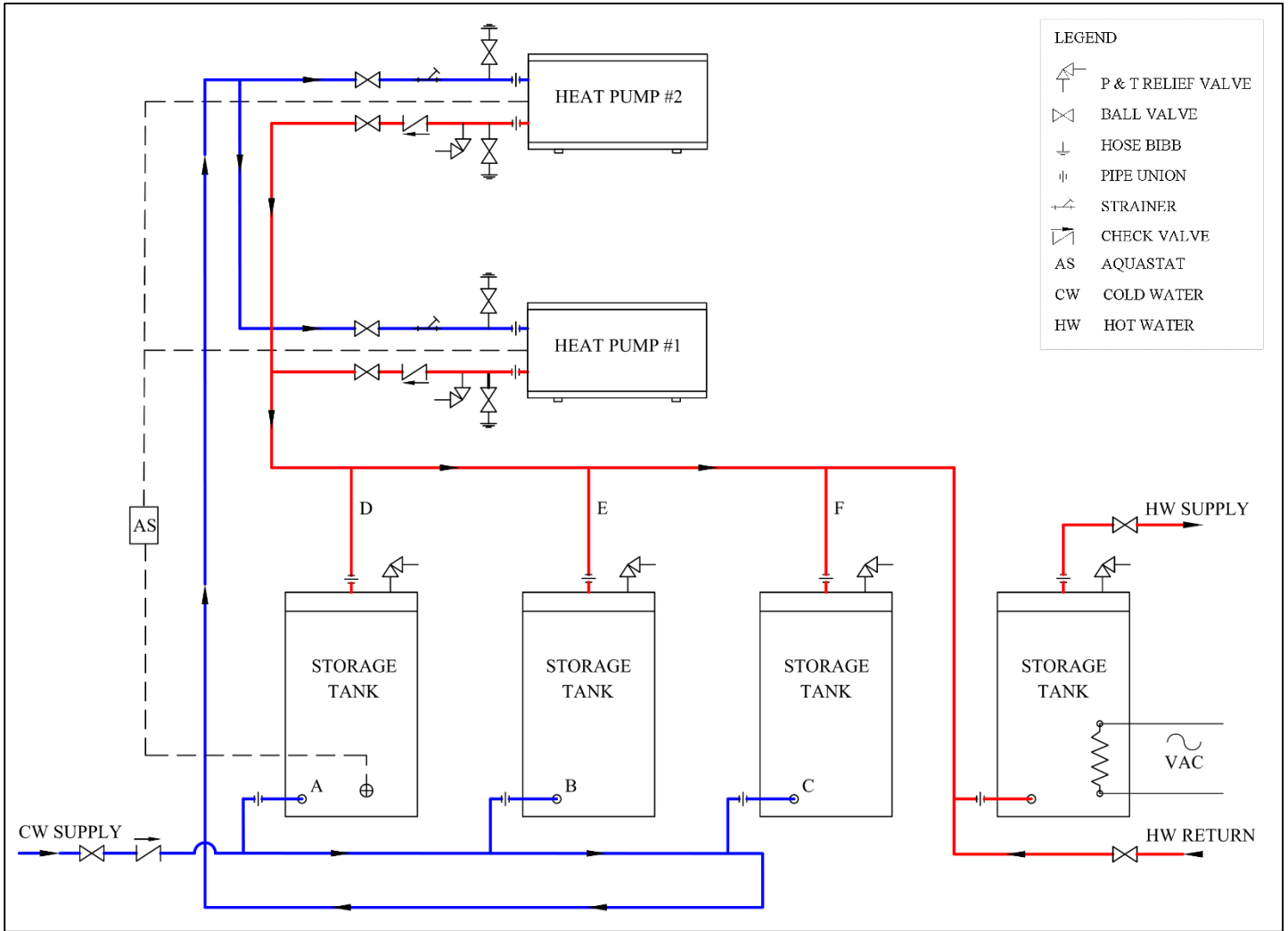

Figure 4

1.1. POOR

1.1.1.

Storage tanks in series, single aquastat, poor hot water return location

Aquastat setpoint and differential:

Setpoint: 110°F (End call for heat at 110°F)

Differential: 30°F (Start call for heat at 80°F)

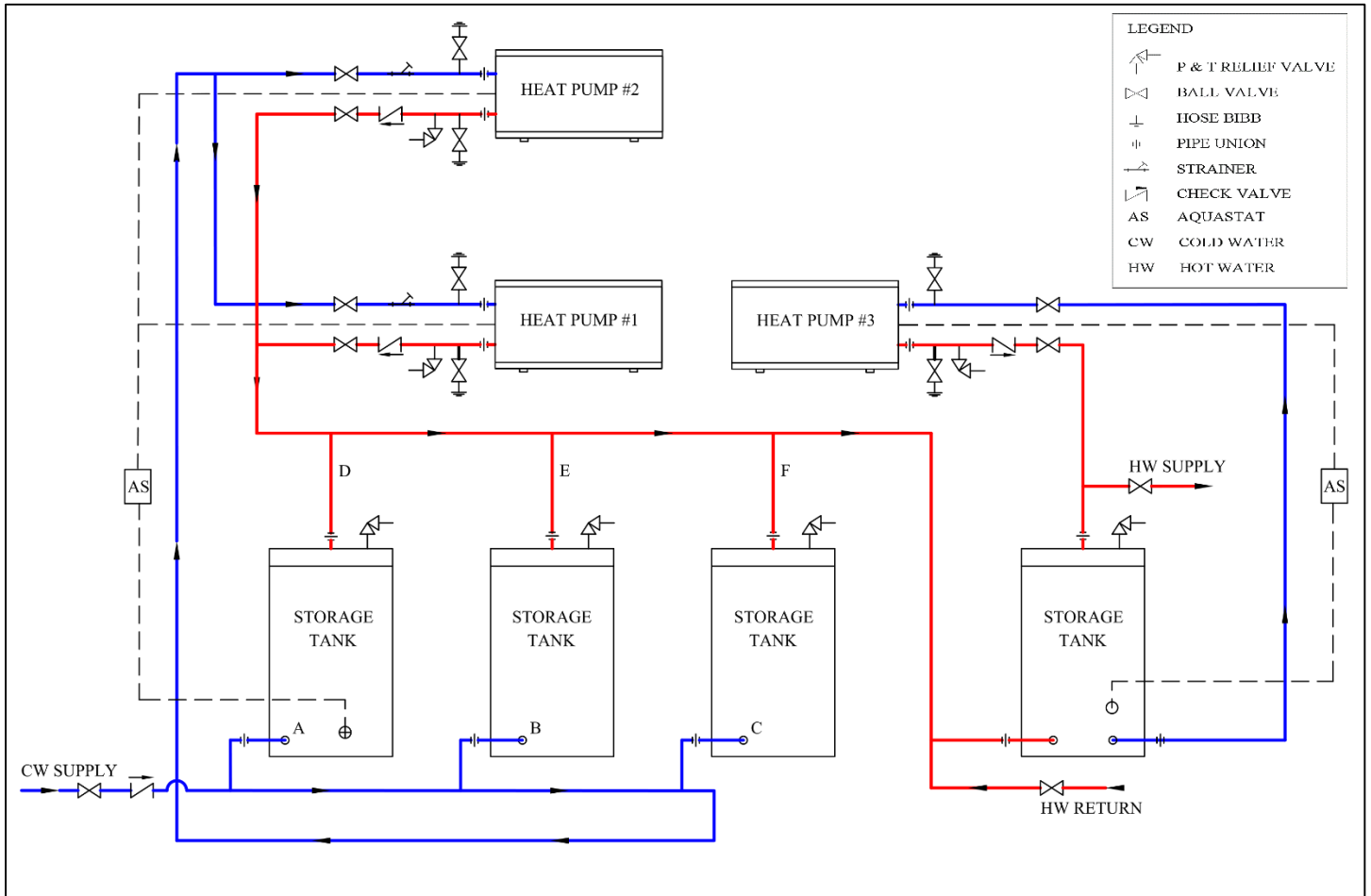

Figure 5

Storage tanks in series, poorly located single aquastat, bad setpoints, heated building return

Aquastat setpoint and differential:

Setpoint: 140°F (End call for heat at 140°F)

Differential: 5°F - 10°F (Start call for heat at 135°F - 130°F)

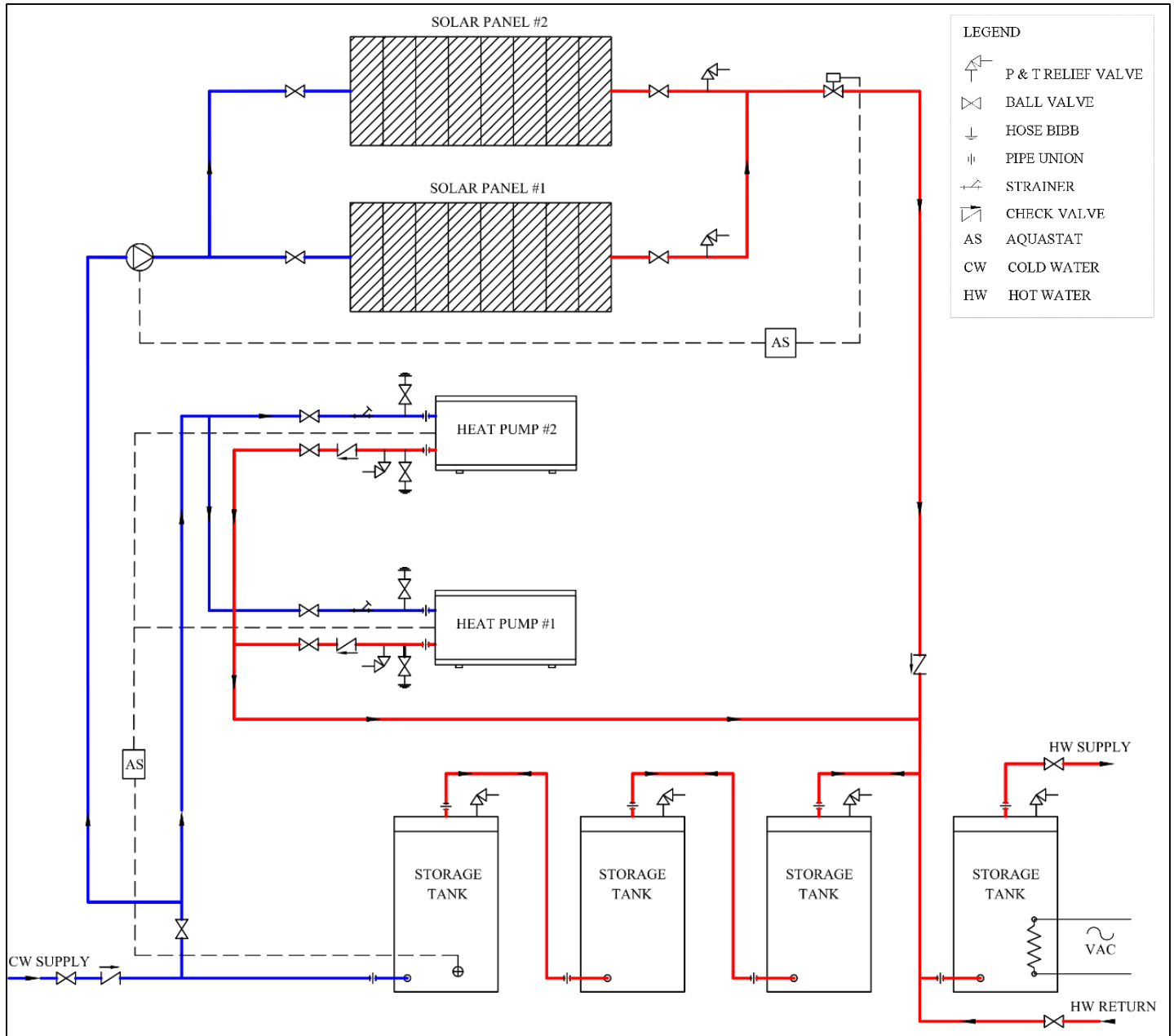

Figure 6

Storage tanks in parallel (reverse return), poorly located single aquastat with bad setpoints, heated building return

Aquastat setpoint and differential:

Setpoint: 140°F (End call for heat at 140°F)

Differential: 5°F - 10°F (Start call for heat at 135°F - 130°F)

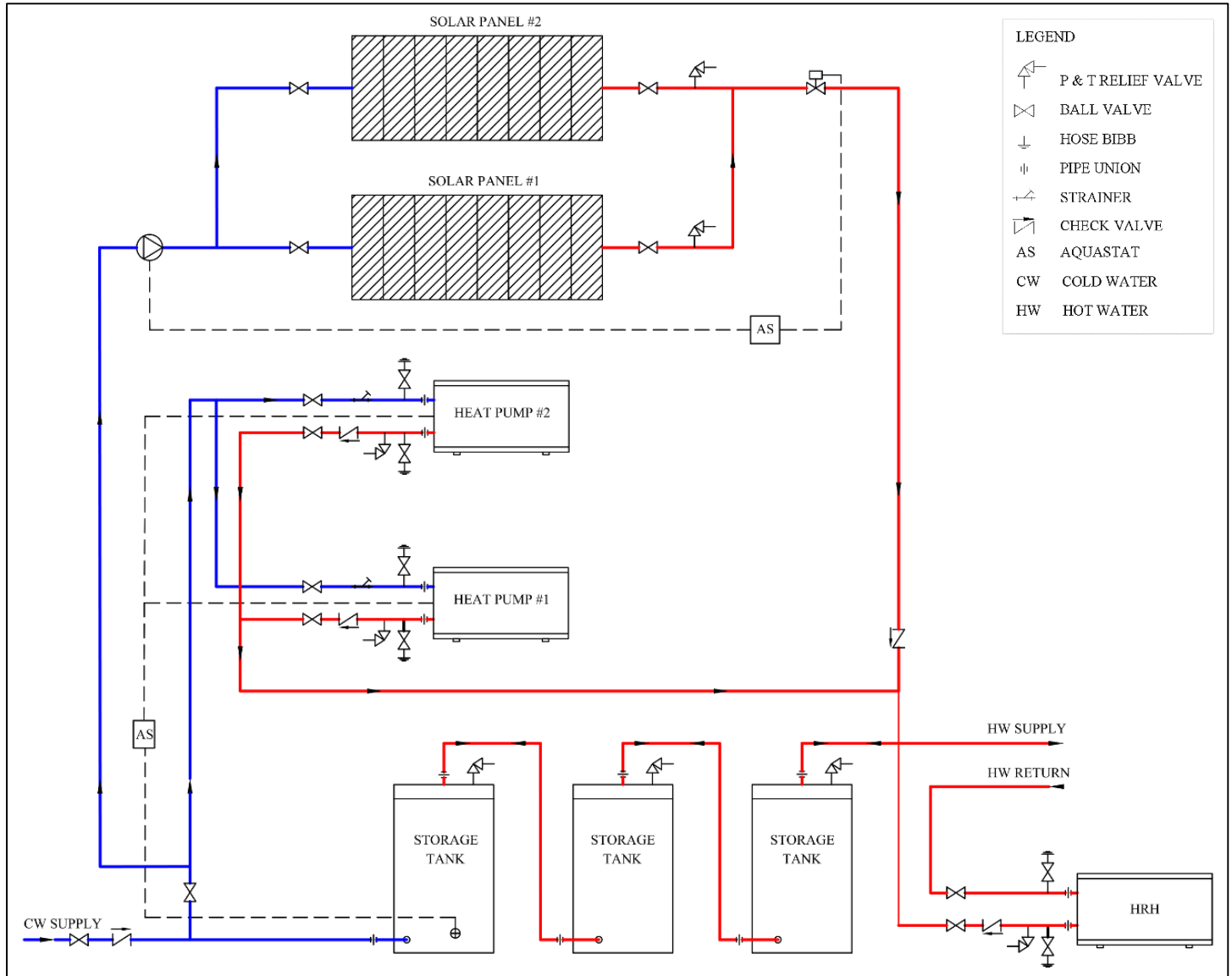

Figure 7

Multi-zone tall building with heat pump water heating for recirculation loop line losses.

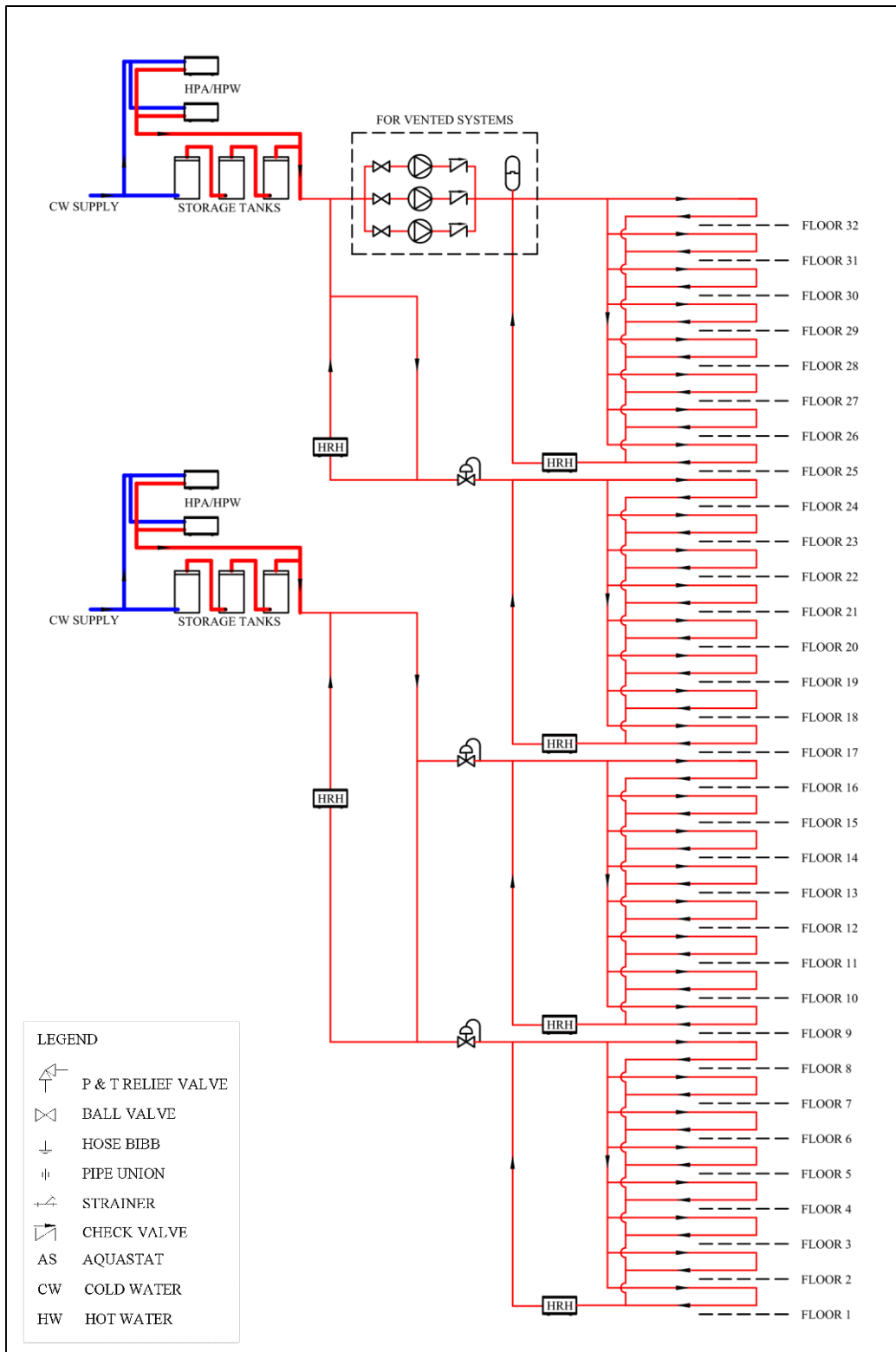

Figure 8



Colmac reserves the right to change product design and specifications without notice.

For more information on Colmac products call us at 1-800-926-5622 or visit us online at:

WWW.COLMACWATERHEAT.COM



July 27, 2020

VIA EMAIL

Anthony E. Valdez
Commission Secretary
Commission on the Environment
City of San Francisco
1455 Market Street, Suite 1200
San Francisco, CA 94103

To the Commission on the Environment:

On behalf of our 95,000 California members who have an interest in transitioning to a thriving climate-safe society while receiving affordable energy services, we are writing to support Supervisor Mandelman’s proposed ordinance requiring all-electric buildings for new construction. Local jurisdictions across the state have adopted “reach” building energy codes to decarbonize their building sectors, and San Francisco has the opportunity to be a leader in this movement by requiring that all new buildings be designed and built to use clean electricity, leading to better air quality and zero climate emissions.

We commend Supervisor Mandelman and City staff for coordinating a comprehensive and inclusive stakeholder process, leading to a robust ordinance that avoids unnecessary exemptions while providing flexibility where really needed.

The Ordinance Will Protect the Health and Safety of San Francisco Residents

Gas appliances in buildings make up a quarter of California’s nitrogen oxide (NO_x) emissions from fossil gas. NO_x is a precursor to ozone and a key pollutant to curb in order to comply with state and federal ambient air quality standards. Electrifying buildings will help reduce NO_x and ground level ozone, improving *outdoor* air quality and benefiting public health. A recent study from the UCLA Fielding School of Public Health found that immediate replacement of all residential gas appliances with clean electric alternatives would result in 354 fewer deaths, 596 fewer cases of acute bronchitis, and 304 fewer cases of chronic bronchitis

annually in California due to improvements in outdoor air quality alone—the monetized equivalent of \$3.5 billion in health benefits per year.¹

Electrification of fossil fuel appliances will also immediately improve *indoor* air quality and health. On average, Californians spend 68 percent of their time indoors, making indoor air quality a key determinant of human health.² The combustion of gas in household appliances produces harmful indoor air pollution, specifically nitrogen dioxide, carbon monoxide, nitric oxide, formaldehyde, acetaldehyde, and ultrafine particles, often in excess of the levels set out by the California Ambient Air Quality Standards and the National Ambient Air Quality Standards.^{3,4} The California Air Resources Board warns that “cooking emissions, especially from gas stoves, have been associated with increased respiratory disease.”⁵ Young children and people with asthma are especially vulnerable to indoor air pollution, and the negative health impacts associated with gas appliance use disproportionately affect low-income residents, who are often renters rather than homeowners and tend to live in smaller spaces, resulting in higher concentration of indoor air pollutants.⁶

The Ordinance is a Critical Step in Fighting the Climate Emergency

Stationary energy use represents a major source of greenhouse gas (“GHG”) emissions, much of which comes from gas end uses, such as space and water heating. In *Residential Building Electrification in California*, E3 determined that “electrification is found to reduce total greenhouse gas emissions in single family homes by approximately 30 to 60 percent in 2020, relative to a gas-fueled home.”⁷ Moreover, “[a]s the carbon intensity of the grid decreases over time, these savings are estimated to increase to approximately 80 to 90 percent by 2050, including the impacts of upstream methane leakage and refrigerant gas leakage from air conditioners and heat pumps.”⁸

Building electrification brings significant GHG reductions, not only due to the energy mix on the grid, which was, in PG&E’s and CleanPowerSF’s service territories, respectively, 85

¹ Zhu, *et al.*, *Effects of Residential Gas Appliances on Indoor and Outdoor Air Quality and Public Health in California*, UCLA Fielding School of Public Health (April 2020).

² Klepeis *et al.*, *The National Human Activity Pattern Survey (NHAPS): A Resource for Assessing Exposure to Environmental Pollutants*, J. EXPO. ANAL. ENVIRON. EPIDEMIOL., Vol. 11(3), 231-52 (2001).

³ See, e.g., Logue *et al.*, *Pollutant Exposures from Natural Gas Cooking Burners: A Simulation-Based Assessment for Southern California*, ENVIRON. HEALTH PERSP., Vol. 122(1), 43-50 (2014); Victoria Klug & Brett Singer, *Cooking Appliance Use in California Homes—Data Collected from a Web-based Survey*, LAWRENCE BERKELEY NATIONAL LABORATORY (Aug. 2011); John Manuel, *A Healthy Home Environment?* ENVIRON. HEALTH PERSP., Vol. 107(7), 352-57 (1999); Mullen *et al.*, *Impact of Natural Gas Appliances on Pollutant Levels in California Homes*, LAWRENCE BERKELEY NATIONAL LABORATORY (2012).

⁴ Zhu, *et al.*, at 12-13.

⁵ California Air Resources Board, *Combustion Pollutants* (last reviewed Jan. 19, 2017), <https://www.arb.ca.gov/research/indoor/combustion.htm>.

⁶ Zhu, *et al.*, at 10.

⁷ E3, *Residential Building Electrification in California* at iv (Apr. 2019), https://www.ethree.com/wp-content/uploads/2019/04/E3_Residential_Building_Electrification_in_California_April_2019.pdf.

⁸ *Id.*

and 89 percent carbon-free in 2018,⁹ but also because heat pump technology is extraordinarily efficient. Rather than needing to generate heat through the combustion of fossil gas, heat pumps extract existing heat from the surrounding environment. Because electricity is used to move heat around rather than to create it, heat pump efficiency is far greater than 100 percent (energy services delivered are much greater than energy input). Accordingly, heat pumps use much less energy to heat water,¹⁰ and generate significantly less GHGs than even the most efficient gas water heating.¹¹

The Ordinance Will Develop the Local Workforce

Building electrification will also spur development of the local workforce for jobs that will be critical in California's broader energy transition. For example, in Sacramento Municipal Utility District territory, where all-electric buildings are quickly becoming the default for new developments, demand for specialized plumbers and HVAC technicians is expected to grow enormously. The region expects to install more than 300,000 heat pump space heaters in the next 15 to 20 years.¹² Additionally, a 2019 study from the UCLA Luskin Center for Innovation found that electrification of 100 percent of California's existing and new buildings by 2045 would generate new jobs for more than 100,000 full time construction workers and up to 4,900 full time manufacturing workers.¹³ While gas distribution jobs would decrease, they are projected to be replaced by almost double the amount of full time jobs in electricity generation and distribution.¹⁴

Further, because California imports 90 percent of its gas from out of state, it can reduce gas imports first while preserving in-state gas industry jobs, which will ease the strain of industry transition on gas industry workers.¹⁵ The UCLA study stresses that planning—including implementing and enforcing clear building codes and standards—will be crucial in protecting workers through an industry transition that is already underway.¹⁶ Recognizing the widespread energy transition already underway statewide, San Francisco has an opportunity to lead California's major urban centers by developing a robust, comprehensive local legal framework to support electrification and generate thousands of good, green jobs for its residents.

⁹ PG&E, Corporate Responsibility and Sustainability Report: 2019, at 38. Available at:

http://www.pgecorp.com/corp_responsibility/reports/2019/assets/PGE_CRSR_2019.pdf; CleanPowerSF Power Draft Power Content Label: 2018. Available at: <https://www.cleanpowersf.org/s/2018-CleanPowerSF-PCL.pdf>.

¹⁰ See Pub. Util. Code § 397.6(k)(3) (a measure of SGIP success and impact is the “amount of energy reductions measured in energy value.”).

¹¹ See Pub. Util. Code § 379.6(k)(1) (a measure of SGIP success and impact is the “amount of reductions of emissions of greenhouse gases.”).

¹² Justin Gerdes, *Experts Discuss the Biggest Barriers Holding Back Building Electrification*, Greentech Media (Sept. 19, 2018), <https://www.greentechmedia.com/articles/read/here-are-some-of-the-biggest-barriers-holding-back-building-electrification#gs.fBEBKJy2>.

¹³ UCLA Luskin Center for Innovation, *California Building Decarbonization: Workforce Needs and Recommendations*, at ES-iv (Nov. 2019).

¹⁴ *Id.*

¹⁵ *Id.* at 24-25.

¹⁶ *Id.* at 27-28.

In light of this, we support the all-electric construction ordinance, not only as a response to the climate emergency, but also in support of new jobs and the health and safety of the people of San Francisco. To fully realize these benefits, avoid unnecessary stranded asset consequences of continued buildout of gas infrastructure, and ensure the City's actions are commensurate with the urgency of the climate crisis, it is critical that any exemptions to all-electric new construction be as narrowly tailored as possible and avoid the potential for loopholes. We therefore urge staff to implement the ordinance in a way that ensures exemptions are in legitimately exceptional circumstances.

Thank you for your leadership in moving San Francisco forward in realizing the many benefits of clean energy homes and buildings.

Sincerely,

Pierre Delforge
Senior Scientist
Natural Resources Defense Council
111 Sutter St, 21st Floor
San Francisco, CA 94104
(415) 875-6139
pdelforge@nrdc.org

cc: Aaron.Peskin@sfgov.org
Sunny.Angulo@sfgov.org
Lee.Hepner@sfgov.org
Ahsha.Safai@sfgov.org
Suhagey.Sandoval@sfgov.org
Dean.Preston@sfgov.org
Jen.Snyder@sfgov.org
Kyle.Smeallie@sfgov.org
Rafael.Mandelman@sfgov.org
Jacob.Bintliff@sfgov.org
mandelmanstaff@sfgov.org
Deborah.Raphael@sfgov.org
Patrick.O'Riordan@sfgov.org
Board.of.Supervisors@sfgov.org
Erica.Major@sfgov.org
Sonya.Harris@sfgov.org

From: [Rebecca Barker](#)
To: [Tanenberg, Diedre \(ENV\)](#)
Cc: mvespa@earthjustice.org; [Sheehan, Charles \(ENV\)](#); [Peskin, Aaron \(BOS\)](#); [Angulo, Sunny \(BOS\)](#); [Hepner, Lee \(BOS\)](#); [Safai, Ahsha \(BOS\)](#); [Sandoval, Suhagey \(BOS\)](#); [Preston, Dean \(BOS\)](#); [Snyder, Jen \(BOS\)](#); [Smeallie, Kyle \(BOS\)](#); [Mandelman, Rafael \(BOS\)](#); [Bintliff, Jacob \(BOS\)](#); [MandelmanStaff, \[BOS\]](#); [Raphael, Deborah \(ENV\)](#); patrick.o.riordan@sfgov.org; [Board of Supervisors, \(BOS\)](#); [Major, Erica \(BOS\)](#); [Harris, Sonya \(DBI\)](#); dktahara@gmail.com; c@n-a-s-o.com; matt.gough@sierraclub.org
Subject: Comment Letter for July 28 Commission on the Environment Meeting
Date: Monday, July 27, 2020 4:50:45 PM
Attachments: [ATT00001.png](#)
[BE Ordinance Letter of Support from Earthjustice, SC, SFCEC, and Allies.pdf](#)

This message is from outside the City email system. Do not open links or attachments from untrusted sources.

Hello,

Attached please find a letter from Earthjustice, Sierra Club, SF Climate Emergency Coalition, and many more allied organizations in support of the building electrification ordinance (Board of Supervisors File No. 200701) listed as agenda item #7 for the Commission on the Environment's July 28 meeting. Please don't hesitate to reach out with any questions or concerns.

Thank you,
Rebecca Barker

Rebecca Barker
She/her/hers
Associate Attorney
Clean Energy Program
50 California Street, Suite 500
San Francisco, CA 94111
Phone: 415.217.2056
rbarker@earthjustice.org



The information contained in this email message may be privileged, confidential and protected from disclosure. If you are not the intended recipient, any dissemination, distribution or copying is strictly prohibited. If you think that you have received this email message in error, please notify the sender by reply email and delete the message and any attachments.



July 27, 2020

VIA EMAIL

Diedre Tanenberg
 Public Affairs Assistant Coordinator
 Commission on the Environment
 City of San Francisco
 1455 Market Street, Suite 1200
 San Francisco, CA 94103
 diedre.tanenberg@sfgov.org

To the Commission on the Environment:

We are writing to support Supervisor Mandelman’s proposed ordinance requiring all-electric buildings for new construction. Local jurisdictions across the state have amended their reach codes or introduced ordinances to decarbonize their building sectors, and San Francisco has the opportunity to emerge as a leader in this movement by taking a strong stance against fossil fuels and requiring all-electric construction in all new building projects.

We commend Supervisor Mandelman and the numerous stakeholder groups he engaged for taking the initiative to develop and introduce this important legislation. In addition, to more fully realize the health, climate and economic benefits of electrification and ensure that any exemptions to this important requirement are under legitimately exceptional circumstances, we ask that the following changes be made to strengthen the ordinance and implementing regulations:

- 1) eliminate the blanket exemption for commercial kitchens delaying compliance until 2022;
- 2) eliminate the feasibility exception to the electric-ready requirement;
- 3) expand and clarify the definition of “Mixed-Fuel Buildings” in the ordinance to include laboratory and industrial buildings, as well as decorative uses of gas; and
- 4) provide additional limitations and transparency in the exemption process to ensure any project found exempt for infeasibility is truly in the public interest.

The Ordinance Will Protect the Health and Safety of San Francisco Residents

Gas appliances in buildings make up a quarter of California’s nitrogen oxide (NO_x) emissions from natural gas. NO_x is a precursor to ozone and particulate matter, which are key pollutants to curb in order to comply with state and federal ambient air quality standards. Electrifying buildings will help reduce NO_x and ground level ozone, improving *outdoor* air quality and benefiting public health. A recent study from the UCLA Fielding School of Public Health found that immediate replacement of all residential gas appliances with clean electric alternatives would result in 354 fewer deaths, 596 fewer cases of acute bronchitis, and 304 fewer cases of chronic bronchitis *annually* in California due to improvements in outdoor air quality alone—the monetized equivalent of \$3.5 billion in health benefits per year.¹

Electrification of fossil fuel appliances will also immediately improve *indoor* air quality and health. On average, Californians spend 68 percent of their time indoors, making indoor air quality a key determinant of human health.² The combustion of gas in household appliances produces harmful indoor air pollution, specifically nitrogen dioxide, carbon monoxide, nitric oxide, formaldehyde, acetaldehyde, and ultrafine particles, often in excess of the levels set out by the California Ambient Air Quality Standards and the National Ambient Air Quality Standards.³

¹ Zhu, *et al.*, *Effects of Residential Gas Appliances on Indoor and Outdoor Air Quality and Public Health in California*, UCLA Fielding School of Public Health (April 2020).

² Klepeis *et al.*, *The National Human Activity Pattern Survey (NHAPS): A Resource for Assessing Exposure to Environmental Pollutants*, J. EXPO. ANAL. ENVIRON. EPIDEMIOL., Vol. 11(3), 231-52 (2001).

³ See, e.g., Logue *et al.*, *Pollutant Exposures from Natural Gas Cooking Burners: A Simulation-Based Assessment for Southern California*, ENVIRON. HEALTH PERSP., Vol. 122(1), 43-50 (2014); Victoria Klug & Brett Singer, *Cooking Appliance Use in California Homes—Data Collected from a Web-based Survey*, LAWRENCE BERKELEY NATIONAL LABORATORY (Aug. 2011); John Manuel, *A Healthy Home Environment?* ENVIRON. HEALTH PERSP.,

⁴ The California Air Resources Board warns that “cooking emissions, especially from gas stoves, have been associated with increased respiratory disease.”⁵ Young children and people with asthma are especially vulnerable to indoor air pollution, and the negative health impacts associated with gas appliance use disproportionately affect low-income residents, who are often renters rather than homeowners and tend to live in smaller spaces, resulting in higher concentration of indoor air pollutants.⁶

Chronic exposure to air pollution has also been linked to poor health outcomes during the COVID-19 crisis.⁷ A study from the Harvard T.H. Chan School of Public Health analyzed data from more than 3,000 counties across the United States to assess the link between long-term average exposure to air pollutants and COVID-19 death rates. The study found that “an increase of only $1 \mu\text{g}/\text{m}^3$ in $\text{PM}_{2.5}$ is associated with an 8% increase in the COVID-19 death rate,” meaning even small increases in long-term exposure to particulate matter can translate into significant increases in county-wide death rates from the virus.⁸ This data is a stark reminder of the devastating effects that air pollution has on affected communities, and underscores the need for major urban centers like San Francisco both to uphold existing safeguards against air pollution and to take a strong stance moving forward to protect the health and safety of their residents.

The Ordinance is a Critical Step in Fighting the Climate Emergency

Stationary energy use represents a major source of greenhouse gas (“GHG”) emissions, much of which comes from gas end uses, such as space and water heating. In *Residential Building Electrification in California*, E3 determined that “electrification is found to reduce total greenhouse gas emissions in single family homes by approximately 30 to 60 percent in 2020, relative to a natural gas-fueled home.”⁹ Moreover, “[a]s the carbon intensity of the grid decreases over time, these savings are estimated to increase to approximately 80 to 90 percent by 2050, including the impacts of upstream methane leakage and refrigerant gas leakage from air conditioners and heat pumps.”¹⁰

Building electrification brings significant GHG reductions, not only due to the energy mix on the grid, which was, in PG&E’s and CleanPowerSF’s service territories, respectively, 85

Vol. 107(7), 352-57 (1999); Mullen *et al.*, *Impact of Natural Gas Appliances on Pollutant Levels in California Homes*, LAWRENCE BERKELEY NATIONAL LABORATORY (2012).

⁴ Zhu, *et al.*, at 12-13.

⁵ California Air Resources Board, *Combustion Pollutants* (last reviewed Jan. 19, 2017), <https://www.arb.ca.gov/research/indoor/combustion.htm>.

⁶ Zhu, *et al.*, at 10.

⁷ Wu, *et al.*, *Exposure to Air Pollution and COVID-19 Mortality in the United States: A Nationwide Cross-Sectional Study*, Harvard T.H. Chan School of Public Health (updated April 24, 2020).

⁸ *Id.*

⁹ E3, *Residential Building Electrification in California* at iv (Apr. 2019), https://www.ethree.com/wp-content/uploads/2019/04/E3_Residential_Building_Electrification_in_California_April_2019.pdf.

¹⁰ *Id.*

and 89 percent carbon-free in 2018,¹¹ but also because heat pump technology is extraordinarily efficient. Rather than needing to generate heat through the combustion of fossil gas, heat pumps extract existing heat from the surrounding environment. Because electricity is used to move heat around rather than to create it, heat pump water heater (“HPWH”) efficiency is far greater than 100 percent (energy services delivered are much greater than energy input). Accordingly, HPWHs use much less energy to heat water,¹² and HPWHs generate significantly less GHGs than even the most efficient gas water heating.¹³

Industry leaders have shown that all-electric construction is feasible for all building types, from single-family residences to large, commercial buildings.¹⁴ For example, Stanford University has converted its campus from a system reliant on a fossil-fuel-based combined heat and power plant to a mix of grid-sourced electricity and an electric heat recovery system that uses heat pump technology to store thermal energy and to meet the campus’s space and water heating needs, reducing the GHG impact of its roughly 12 million square feet of building stock by 68% below peak levels.¹⁵ Similar all-electric retrofits and new construction have been adopted for large-scale corporate campuses like Tesla and Google, among others.¹⁶ These resounding success stories support a comprehensive gas ban that covers all building types, avoiding a slow, piecemeal transition.

The Ordinance Will Develop the Local Workforce

Building electrification will also spur development of the local workforce for jobs that will be critical in California’s broader energy transition. For example, in Sacramento Municipal Utility District territory, where all-electric buildings are quickly becoming the default for new developments, demand for specialized plumbers and HVAC technicians is expected to grow enormously. The region expects to install more than 300,000 heat pump space heaters in the next 15 to 20 years.¹⁷ Additionally, a 2019 study from the UCLA Luskin Center for Innovation found that electrification of 100 percent of California’s existing and new buildings by 2045 would generate new jobs for more than 100,000 full time construction workers and up to 4,900

¹¹ PG&E, Corporate Responsibility and Sustainability Report: 2019, at 38. Available at:

http://www.pgecorp.com/corp_responsibility/reports/2019/assets/PGE_CRSR_2019.pdf; CleanPowerSF Power Draft Power Content Label: 2018. Available at: <https://www.cleanpowersf.org/s/2018-CleanPowerSF-PCL.pdf>.

¹² See Pub. Util. Code § 397.6(k)(3) (a measure of SGIP success and impact is the “amount of energy reductions measured in energy value.”).

¹³ See Pub. Util. Code § 379.6(k)(1) (a measure of SGIP success and impact is the “amount of reductions of emissions of greenhouse gases.”).

¹⁴ Redwood Energy, *Zero Carbon Commercial Construction: An Electrification Guide for Large Commercial Buildings and Campuses* (2019). Available at: <https://www.redwoodenergy.tech/wp-content/uploads/2019/09/Pocket-Guide-to-Zero-Carbon-Commercial-Buildings-2nd-Edition.pdf>

¹⁵ Stanford University, *Stanford Energy Systems Innovations Fact Sheet*. Available at: https://sustainable.stanford.edu/sites/default/files/SESI_Condensed_factsheet2017.pdf. See also Stanford University, *Energy and Climate Plan*. Available at: <https://sustainable.stanford.edu/sites/default/files/E%26C%20Plan%202016.6.7.pdf>.

¹⁶ Redwood Energy, at 3-4.

¹⁷ Justin Gerdes, *Experts Discuss the Biggest Barriers Holding Back Building Electrification*, Greentech Media (Sept. 19, 2018), <https://www.greentechmedia.com/articles/read/here-are-some-of-the-biggest-barriers-holding-back-building-electrification#gs.fBEBKJy2>.

full time manufacturing workers.¹⁸ While gas distribution jobs would decrease, they are projected to be replaced by almost double the amount of full time jobs in electricity generation and distribution.¹⁹ Further, because California imports 90 percent of its natural gas from out of state, it can reduce gas imports first while preserving in-state gas industry jobs, which will ease the strain of industry transition on gas industry workers.²⁰ The UCLA study stresses that planning—including implementing and enforcing clear building codes and standards—will be crucial in protecting workers through an industry transition that is already underway.²¹ Recognizing the widespread energy transition already underway statewide, San Francisco has an opportunity to lead California’s major urban centers by developing a robust, comprehensive local legal framework to support electrification and generate thousands of good, green jobs for its residents.

In light of this, we commend the introduction of an all-electric construction ordinance, not only as a response to the climate emergency, but also in support of new jobs and the health and safety of the people of San Francisco. To fully realize these benefits, avoid unnecessary stranded asset consequences of continued buildout of gas infrastructure, and ensure the City’s actions are commensurate with the urgency of the climate crisis, it is critical that any exemptions to all-electric new construction be as narrowly tailored as possible and avoid the potential for loopholes. We therefore urge the following modification to the ordinance and implemented code to ensure exemptions are in legitimately exceptional circumstances.

1. Eliminate the blanket exemption for commercial kitchens delaying compliance until 2022. Restaurant workers who spend hours working in commercial kitchens daily are at particularly high risk for the negative health effects of gas stoves. Additionally, because this ordinance affects only new construction, this exemption does not stand to benefit existing local small businesses, but rather, caters to developers seeking to build brand-new commercial spaces. This exemption does not protect the interests of the local restaurant owners and will delay the transition to a fully decarbonized building stock with no balancing benefit in the public interest. An all-electric requirement with no categorical exemptions or delays is commensurate with the urgency of the climate crisis.

2. Eliminate the feasibility exception to the electric-ready requirement and make fully electric-ready construction a baseline requirement for new construction. To avoid creating obstacles to future electrification, any new construction project that is found exempt from the all-electric requirement due to infeasibility must be required, as a baseline, to adhere to an electric-ready design, *i.e.*, to install sufficient electric service, conduit, and wiring to facilitate full building electrification in the future.

¹⁸ UCLA Luskin Center for Innovation, *California Building Decarbonization: Workforce Needs and Recommendations*, at ES-iv (Nov. 2019).

¹⁹ *Id.*

²⁰ *Id.* at 24-25.

²¹ *Id.* at 27-28.

An electric-ready requirement as an interim step will ensure that developers do not push gas-reliant projects through the exemption process for physical infeasibility, which will ultimately be costly and burdensome to retrofit.

3. Expand the ordinance’s definition of “mixed-fuel buildings” to include laboratory, industrial, and decorative uses of gas. As written, the definition of “mixed-fuel buildings” limits the application of the ordinance just to buildings using gas for “space heating or cooling, water heating (including pools and spas), cooking appliances or clothes drying appliances, [or] onsite generation of electricity,” or buildings that contain “fixtures, piping systems, or infrastructure for natural gas or propane equipment *for such uses.*” Amending this definition to include laboratory, industrial, and decorative uses of gas (e.g., outdoor fireplaces or lamps) will ensure comprehensive application of the ordinance, as intended, subject to the infeasibility exemption on a case-by-case basis.

4. Provide additional limitations and transparency in the exemption process to ensure any project found exempt for infeasibility is truly in the public interest. The current proposed process for reviewing exemptions for physical infeasibility would take place behind closed doors with no opportunity for public comment or appeal. Without additional safeguards in place, developers may take advantage of the process to advance projects that do not serve the health and safety interests of the public, including the future workers and/or residents of the proposed development. A more transparent review process will enable public engagement and greater public confidence that exemptions are limited and made only in legitimately exceptional circumstances.

Further, amending section 106A.1.17 to require that that Building Official find “sufficient evidence was submitted to substantiate the infeasibility of an All-Electric Building or Project design *without regard to financial, floor-area, or amenity-related loss unless deemed to be in the public welfare,*” would prevent developers from designing projects that claim physical infeasibility to avoid using space inside the building to house the necessary equipment. This amendment ensures the focus remains on public health and welfare, rather than profit maximization for developers and landlords, while giving the Building Official discretion to determine case-specific exemptions that may serve the public interest.

Thank you for your leadership in moving San Francisco forward in realizing the many benefits of healthy fossil fuel free homes. Please do not hesitate to reach out if you have any questions, and please include us on your contact list for any further developments on the proposed ordinance.

Sincerely,

Rebecca Barker
Earthjustice

Matthew Gough
Sierra Club

Amanda Millstein, M.D.
Climate Health Now

Chris Naso
Ban Natural Gas San Francisco Campaign

Daniel Tahara
San Francisco Climate Emergency Coalition

Denise Grab
Rocky Mountain Institute

Shoshana Wechsler
Sunflower Alliance

Sean Armstrong
Redwood Energy

Barbara Sattler, RN, DrPH, FAAN
Alliance of Nurses for Healthy Environments

Laura Neish
350 Bay Area

Elena Engel
350 SF

Barry Hermanson
Sierra Club – San Francisco Bay Chapter

Maia Piccagli
Mothers Out Front San Francisco

Alexandra Nagy
Food & Water Action

Joni Eisen
San Francisco Chapter
Citizens' Climate Lobby

Josh Lee
Sunrise Movement Bay Area

Paul Wermer
Helena Birecki
Climate Reality Project

Joni Eisen
San Francisco Tomorrow

Bronwyn Barry
North American Passive House Network

Andréa Traber
Integral Group

Khanh Nguyen
PIVOT:
The Progressive Vietnamese American
Organization

Bob Gould
San Francisco Bay Chapter
Physicians for Social Responsibility

Rachelle Boucher
Kitchens to Life

Saul Griffith
Otherlab

Alter Consulting Engineers

Linda Hutchins-Knowles
Mothers Out Front California

Antonio Díaz
Chris Selig
PODER
People Organizing to Demand Environmental
& Economic Rights

cc: charles.sheehan@sfgov.org
Aaron.Peskin@sfgov.org
Sunny.Angulo@sfgov.org
Lee.Hepner@sfgov.org
Ahsha.Safai@sfgov.org
Suhagey.Sandoval@sfgov.org
Dean.Preston@sfgov.org
Jen.Snyder@sfgov.org
Kyle.Smeallie@sfgov.org
Rafael.Mandelman@sfgov.org
Jacob.Bintliff@sfgov.org
mandelmanstaff@sfgov.org
Deborah.Raphael@sfgov.org
Patrick.O'Riordan@sfgov.org
Board.of.Supervisors@sfgov.org
Erica.Major@sfgov.org
Sonya.Harris@sfgov.org

From: [Arman Khatchatrian](#)
To: [Major, Erica \(BOS\)](#)
Subject: Balboa Reservoir Project Case #s: 200422 (SUD), 200635 (General Plan), 200423 (Development Agreement) and 200740 (Purchase and Sale Agreement)
Date: Monday, July 20, 2020 9:22:56 AM

This message is from outside the City email system. Do not open links or attachments from untrusted sources.

Erica Major,

My name is Arman Khatchatrian and I live in the Glen Park neighborhood. I have been participating in the community planning process for the Balboa Reservoir and am writing in support of the development proposal being reviewed by the Land Use Committee and on July 27, 2020 and Budget and Finance Committee on July 29, 2020.

Living in San Francisco, we have an opportunity to reduce our reliance on automobiles in order to reduce greenhouse gas emissions, slow global warming, and reduce automobile congestion in our neighborhoods. This can only be done by encouraging residents to use car-alternatives for getting around our City, whether by walking, biking, and using public transit and minimizing private auto trips. The Reservoir Partners development proposal of 1,100 homes is designed to provide new residents access to modes of transportation that will reduce residents' reliance on cars. The multiple direct pedestrian connections to Ocean Avenue and transit, the new protected bike lanes, bike share docking stations, and bicycle parking all allow people to get around the neighborhood without a car. Car share parking pods and memberships will provide residents with auto options, but along with the unbundled parking associated with the apartments, will help decrease car ownership rates.

In terms of neighborhood transit improvements, the Reservoir development's lengthy planning process and the development's contribution of approximately \$10mil for Transportation Sustainability Fees is spurring improvements along Ocean Avenue planned by SFMTA, the Planning Department, and CCSF. As described in their 4/27/20 Community Advisory Committee presentation, SFMTA is proposing to improve the safety and usability of the Geneva/Ocean Avenue intersection as well as west along Ocean Avenue and to reduce delays along the K, 43, and 29 MUNI lines. CCSF is working with the City to significantly increase the width of the sidewalk along the campus frontage from Frida Kahlo Way east towards the BART and MUNI stations. All of these improvements, and more, will help support the City's Vision Zero plan for Ocean Avenue, making it safer for Ocean Avenue's pedestrians, transit riders, and car drivers, neighbors and shoppers alike. Please support this project.

Arman Khatchatrian
armank0089@gmail.com
124 Bemis St.
San Francisco, California 94131

From: [kathie.piccagli](#)
To: [Major, Erica \(BOS\)](#); [Board of Supervisors, \(BOS\)](#); [Preston, Dean \(BOS\)](#); [Peskin, Aaron \(BOS\)](#); [Safai, Ahsha \(BOS\)](#); [Yee, Norman \(BOS\)](#)
Subject: Public Comment Re: BoS File 200701
Date: Wednesday, September 16, 2020 11:55:21 AM

This message is from outside the City email system. Do not open links or attachments from untrusted sources.

Land Use Committee, Board of Supervisors, and Sup. Yee,

I'm a resident of San Francisco writing to strongly support prohibiting gas in new construction. The methane leaks, air pollution, and explosion dangers of natural gas are no longer necessary for the functioning of our homes and businesses. San Francisco can lead the state and the country in building a better future.

In addition to recommending the ordinance, I would also like to ask the Commission to recommend the changes to the ordinance as laid out by Earthjustice, the Sierra Club, the San Francisco Climate Emergency Coalition, and other local groups in their letter to the Commission and Board.

It is important to me that we:

1. Eliminate the feasibility exception to the electric-ready requirement and make fully electric-ready construction a baseline requirement for new construction. We know that the future is electric. Allowing any building to be built that will require massive retrofits in the near future is unacceptable. With full electric readiness, we minimize that retrofit cost.
2. Create a Clean Energy Building Hub through the City and County of San Francisco that provides for the outreach, resources, and education needed to eliminate barriers and maximize opportunity for all-electric new construction to benefit both climate and equity.
3. Expand the ordinance's definition of "mixed-fuel buildings" to include laboratory, industrial, and decorative uses of gas. Gas shouldn't be allowed for upscale decorative uses. It's wrong to harm public health for private enjoyment.
4. Provide additional limitations and transparency in the exemption process to ensure any project found exempt for infeasibility is truly in the public interest. I'm concerned about the news of powerful and connected people being able to get favors from DBI. We need sunshine on the exemption process, and exemptions should only be given in the public interest.
5. Amend section 106A.1.17 to require that the Building Official find "sufficient evidence was submitted to substantiate the infeasibility of an All-Electric Building or Project design without regard to financial, floor-area, or amenity-related loss unless deemed to be in the public welfare. The housing crisis is real. And we need to find ways of fixing it without sacrificing our children's future. The space taken up by a transformer should not be an acceptable reason for

an exemption.

6. Eliminate the blanket exemption for commercial kitchens delaying compliance until 2022. Existing restaurants are not helped by giving builders a pass on making future commercial kitchens all-electric.

Thank you for taking up this important issue and considering the health and safety of our residents and climate.

kathie piccagli
kpiccagli@gmail.com
100 Dorado Terrace
san francisco, California 94112

From: [Jill Stanton](#)
To: [Major, Erica \(BOS\)](#); [Board of Supervisors, \(BOS\)](#); [Preston, Dean \(BOS\)](#); [Peskin, Aaron \(BOS\)](#); [Safai, Ahsha \(BOS\)](#); [Ronen, Hillary](#)
Subject: Public Comment Re: BoS File 200701
Date: Wednesday, September 16, 2020 4:30:17 PM

This message is from outside the City email system. Do not open links or attachments from untrusted sources.

Land Use Committee, Board of Supervisors, and Sup. Ronen,

I'm a resident of San Francisco writing to strongly support prohibiting gas in new construction. The methane leaks, air pollution, and explosion dangers of natural gas are no longer necessary for the functioning of our homes and businesses. San Francisco can lead the state and the country in building a better future.

In addition to recommending the ordinance, I would also like to ask the Commission to recommend the changes to the ordinance as laid out by Earthjustice, the Sierra Club, the San Francisco Climate Emergency Coalition, and other local groups in their letter to the Commission and Board.

It is important to me that we:

1. Eliminate the feasibility exception to the electric-ready requirement and make fully electric-ready construction a baseline requirement for new construction. We know that the future is electric. Allowing any building to be built that will require massive retrofits in the near future is unacceptable. With full electric readiness, we minimize that retrofit cost.
2. Create a Clean Energy Building Hub through the City and County of San Francisco that provides for the outreach, resources, and education needed to eliminate barriers and maximize opportunity for all-electric new construction to benefit both climate and equity.
3. Expand the ordinance's definition of "mixed-fuel buildings" to include laboratory, industrial, and decorative uses of gas. Gas shouldn't be allowed for upscale decorative uses. It's wrong to harm public health for private enjoyment.
4. Provide additional limitations and transparency in the exemption process to ensure any project found exempt for infeasibility is truly in the public interest. I'm concerned about the news of powerful and connected people being able to get favors from DBI. We need sunshine on the exemption process, and exemptions should only be given in the public interest.
5. Amend section 106A.1.17 to require that the Building Official find "sufficient evidence was submitted to substantiate the infeasibility of an All-Electric Building or Project design without regard to financial, floor-area, or amenity-related loss unless deemed to be in the public welfare. The housing crisis is real. And we need to find ways of fixing it without sacrificing our children's future. The space taken up by a transformer should not be an acceptable reason for

an exemption.

6. Eliminate the blanket exemption for commercial kitchens delaying compliance until 2022. Existing restaurants are not helped by giving builders a pass on making future commercial kitchens all-electric.

Thank you for taking up this important issue and considering the health and safety of our residents and climate.

Jill Stanton

jillstanton9@gmail.com

415 Franconia St

San Francisco, California 94110-5735

From: [Nick Reavill](#)
To: [Major, Erica \(BOS\)](#); [Board of Supervisors, \(BOS\)](#); [Preston, Dean \(BOS\)](#); [Peskin, Aaron \(BOS\)](#); [Safai, Ahsha \(BOS\)](#); [Ronen, Hillary](#)
Subject: Public Comment Re: BoS File 200701
Date: Wednesday, September 16, 2020 5:49:54 PM

This message is from outside the City email system. Do not open links or attachments from untrusted sources.

Land Use Committee, Board of Supervisors, and Sup. Ronen,

I'm a resident of San Francisco and constituent of Supervisor Ronen writing to strongly support prohibiting gas in new construction. The methane leaks, air pollution, and explosion dangers of natural gas are no longer necessary for the functioning of our homes and businesses. San Francisco can lead the state and the country in building a better future.

If we are going to fully electrify the economy, which we must to fight the climate crisis, this change to our building codes will have to happen eventually. Why not now, to give people in effected industries a chance to transition (hopefully with support from government).

In addition to recommending the ordinance, I would also like to ask the Commission to recommend the changes to the ordinance as laid out by Earthjustice, the Sierra Club, the San Francisco Climate Emergency Coalition, and other local groups in their letter to the Commission and Board.

It is important to me that we:

1. Eliminate the feasibility exception to the electric-ready requirement and make fully electric-ready construction a baseline requirement for new construction. We know that the future is electric. Allowing any building to be built that will require massive retrofits in the near future is unacceptable. With full electric readiness, we minimize that retrofit cost.
2. Create a Clean Energy Building Hub through the City and County of San Francisco that provides for the outreach, resources, and education needed to eliminate barriers and maximize opportunity for all-electric new construction to benefit both climate and equity.
3. Expand the ordinance's definition of "mixed-fuel buildings" to include laboratory, industrial, and decorative uses of gas. Gas shouldn't be allowed for upscale decorative uses. It's wrong to harm public health for private enjoyment.
4. Provide additional limitations and transparency in the exemption process to ensure any project found exempt for infeasibility is truly in the public interest. I'm concerned about the news of powerful and connected people being able to get favors from DBI. We need sunshine on the exemption process, and exemptions should only be given in the public interest.
5. Amend section 106A.1.17 to require that the Building Official find "sufficient evidence was

submitted to substantiate the infeasibility of an All-Electric Building or Project design without regard to financial, floor-area, or amenity-related loss unless deemed to be in the public welfare. The housing crisis is real. And we need to find ways of fixing it without sacrificing our children's future. The space taken up by a transformer should not be an acceptable reason for an exemption.

6. Eliminate the blanket exemption for commercial kitchens delaying compliance until 2022. Existing restaurants are not helped by giving builders a pass on making future commercial kitchens all-electric.

Thank you for taking up this important issue and considering the health and safety of our residents and climate.

Nick Reavill
nreavill@gmail.com
646 Felton St
San Francisco, California 94134

From: [kevin.meissner](#)
To: [Major, Erica \(BOS\)](#); [Board of Supervisors, \(BOS\)](#); [Preston, Dean \(BOS\)](#); [Peskin, Aaron \(BOS\)](#); [Safai, Ahsha \(BOS\)](#); [Ronen, Hillary](#)
Subject: Public Comment Re: BoS File 200701
Date: Wednesday, September 16, 2020 6:34:50 PM

This message is from outside the City email system. Do not open links or attachments from untrusted sources.

Land Use Committee, Board of Supervisors, and Sup. Ronen,

I'm a resident of San Francisco writing to strongly support prohibiting gas in new construction. The methane leaks, air pollution, and explosion dangers of natural gas are no longer necessary for the functioning of our homes and businesses. San Francisco can lead the state and the country in building a better future.

In addition to recommending the ordinance, I would also like to ask the Commission to recommend the changes to the ordinance as laid out by Earthjustice, the Sierra Club, the San Francisco Climate Emergency Coalition, and other local groups in their letter to the Commission and Board.

It is important to me that we:

1. Eliminate the feasibility exception to the electric-ready requirement and make fully electric-ready construction a baseline requirement for new construction. We know that the future is electric. Allowing any building to be built that will require massive retrofits in the near future is unacceptable. With full electric readiness, we minimize that retrofit cost.
2. Create a Clean Energy Building Hub through the City and County of San Francisco that provides for the outreach, resources, and education needed to eliminate barriers and maximize opportunity for all-electric new construction to benefit both climate and equity.
3. Expand the ordinance's definition of "mixed-fuel buildings" to include laboratory, industrial, and decorative uses of gas. Gas shouldn't be allowed for upscale decorative uses. It's wrong to harm public health for private enjoyment.
4. Provide additional limitations and transparency in the exemption process to ensure any project found exempt for infeasibility is truly in the public interest. I'm concerned about the news of powerful and connected people being able to get favors from DBI. We need sunshine on the exemption process, and exemptions should only be given in the public interest.
5. Amend section 106A.1.17 to require that the Building Official find "sufficient evidence was submitted to substantiate the infeasibility of an All-Electric Building or Project design without regard to financial, floor-area, or amenity-related loss unless deemed to be in the public welfare. The housing crisis is real. And we need to find ways of fixing it without sacrificing our children's future. The space taken up by a transformer should not be an acceptable reason for

an exemption.

6. Eliminate the blanket exemption for commercial kitchens delaying compliance until 2022. Existing restaurants are not helped by giving builders a pass on making future commercial kitchens all-electric.

Thank you for taking up this important issue and considering the health and safety of our residents and climate.

kevin meissner
chimere@gmail.com
1138 treat ave
san francisco, California 94110

From: [elliott helman](#)
To: [Major, Erica \(BOS\)](#); [Board of Supervisors, \(BOS\)](#); [Preston, Dean \(BOS\)](#); [Peskin, Aaron \(BOS\)](#); [Safai, Ahsha \(BOS\)](#); [Haney, Matt \(BOS\)](#)
Subject: Public Comment Re: BoS File 200701
Date: Wednesday, September 16, 2020 8:12:07 PM

This message is from outside the City email system. Do not open links or attachments from untrusted sources.

Land Use Committee, Board of Supervisors, and Sup. Haney,

I'm a resident of San Francisco writing to strongly support prohibiting gas in new construction. The methane leaks, air pollution, and explosion dangers of natural gas are no longer necessary for the functioning of our homes and businesses. San Francisco can lead the state and the country in building a better future.

In addition to recommending the ordinance, I would also like to ask the Commission to recommend the changes to the ordinance as laid out by Earthjustice, the Sierra Club, the San Francisco Climate Emergency Coalition, and other local groups in their letter to the Commission and Board.

It is important to me that we:

1. Eliminate the feasibility exception to the electric-ready requirement and make fully electric-ready construction a baseline requirement for new construction. We know that the future is electric. Allowing any building to be built that will require massive retrofits in the near future is unacceptable. With full electric readiness, we minimize that retrofit cost.
2. Create a Clean Energy Building Hub through the City and County of San Francisco that provides for the outreach, resources, and education needed to eliminate barriers and maximize opportunity for all-electric new construction to benefit both climate and equity.
3. Expand the ordinance's definition of "mixed-fuel buildings" to include laboratory, industrial, and decorative uses of gas. Gas shouldn't be allowed for upscale decorative uses. It's wrong to harm public health for private enjoyment.
4. Provide additional limitations and transparency in the exemption process to ensure any project found exempt for infeasibility is truly in the public interest. I'm concerned about the news of powerful and connected people being able to get favors from DBI. We need sunshine on the exemption process, and exemptions should only be given in the public interest.
5. Amend section 106A.1.17 to require that the Building Official find "sufficient evidence was submitted to substantiate the infeasibility of an All-Electric Building or Project design without regard to financial, floor-area, or amenity-related loss unless deemed to be in the public welfare. The housing crisis is real. And we need to find ways of fixing it without sacrificing our children's future. The space taken up by a transformer should not be an acceptable reason for

an exemption.

6. Eliminate the blanket exemption for commercial kitchens delaying compliance until 2022. Existing restaurants are not helped by giving builders a pass on making future commercial kitchens all-electric.

Thank you for taking up this important issue and considering the health and safety of our residents and climate.

elliot helman

muzungu_x@yahoo.com

626 mission bay blvd N #210

san francisco, California 94158-2497

From: [Maia Piccagli](#)
To: [Major, Erica \(BOS\)](#); [Board of Supervisors, \(BOS\)](#); [Preston, Dean \(BOS\)](#); [Peskin, Aaron \(BOS\)](#); [Safai, Ahsha \(BOS\)](#); [Ronen, Hillary](#)
Subject: Public Comment Re: BoS File 200701
Date: Wednesday, September 16, 2020 8:46:08 PM

This message is from outside the City email system. Do not open links or attachments from untrusted sources.

Land Use Committee, Board of Supervisors, and Sup. Ronen,

I'm a resident of San Francisco District 9, writing to strongly support prohibiting gas in new construction. The methane leaks, air pollution, and explosion dangers of natural gas are no longer necessary for the functioning of our homes and businesses. San Francisco can lead the state and the country in building a better future.

In addition to recommending the ordinance, I would also like to ask the Commission to recommend the changes to the ordinance as laid out by Earthjustice, the Sierra Club, the San Francisco Climate Emergency Coalition, and other local groups in their letter to the Commission and Board.

It is important to me that we:

1. Eliminate the feasibility exception to the electric-ready requirement and make fully electric-ready construction a baseline requirement for new construction. We know that the future is electric. Allowing any building to be built that will require massive retrofits in the near future is unacceptable. With full electric readiness, we minimize that retrofit cost.
2. Create a Clean Energy Building Hub through the City and County of San Francisco that provides for the outreach, resources, and education needed to eliminate barriers and maximize opportunity for all-electric new construction to benefit both climate and equity.
3. Expand the ordinance's definition of "mixed-fuel buildings" to include laboratory, industrial, and decorative uses of gas. Gas shouldn't be allowed for upscale decorative uses. It's wrong to harm public health for private enjoyment.
4. Provide additional limitations and transparency in the exemption process to ensure any project found exempt for infeasibility is truly in the public interest. I'm concerned about the news of powerful and connected people being able to get favors from DBI. We need sunshine on the exemption process, and exemptions should only be given in the public interest.
5. Amend section 106A.1.17 to require that the Building Official find "sufficient evidence was submitted to substantiate the infeasibility of an All-Electric Building or Project design without regard to financial, floor-area, or amenity-related loss unless deemed to be in the public welfare. The housing crisis is real. And we need to find ways of fixing it without sacrificing our children's future. The space taken up by a transformer should not be an acceptable reason for

an exemption.

6. Eliminate the blanket exemption for commercial kitchens delaying compliance until 2022. Existing restaurants are not helped by giving builders a pass on making future commercial kitchens all-electric.

Thank you for taking up this important issue and considering the health and safety of our residents and climate.

Sincerely,
Maia Piccagli

Maia Piccagli
maiapic@gmail.com
1577 Treat Ave
San Francisco, California 94110

From: [Adrienne Gembala](#)
To: [Major, Erica \(BOS\)](#); [Board of Supervisors, \(BOS\)](#); [Preston, Dean \(BOS\)](#); [Peskin, Aaron \(BOS\)](#); [Safai, Ahsha \(BOS\)](#)
Subject: Public Comment Re: BoS File 200701
Date: Wednesday, September 16, 2020 9:01:50 PM

This message is from outside the City email system. Do not open links or attachments from untrusted sources.

Land Use Committee, Board of Supervisors, and Sup. Preston,

I'm a resident of San Francisco writing to strongly support prohibiting gas in new construction. The methane leaks, air pollution, and explosion dangers of natural gas are no longer necessary for the functioning of our homes and businesses. San Francisco can lead the state and the country in building a better future.

In addition to recommending the ordinance, I would also like to ask the Commission to recommend the changes to the ordinance as laid out by Earthjustice, the Sierra Club, the San Francisco Climate Emergency Coalition, and other local groups in their letter to the Commission and Board.

It is important to me that we:

1. Eliminate the feasibility exception to the electric-ready requirement and make fully electric-ready construction a baseline requirement for new construction. We know that the future is electric. Allowing any building to be built that will require massive retrofits in the near future is unacceptable. With full electric readiness, we minimize that retrofit cost.
2. Create a Clean Energy Building Hub through the City and County of San Francisco that provides for the outreach, resources, and education needed to eliminate barriers and maximize opportunity for all-electric new construction to benefit both climate and equity.
3. Expand the ordinance's definition of "mixed-fuel buildings" to include laboratory, industrial, and decorative uses of gas. Gas shouldn't be allowed for upscale decorative uses. It's wrong to harm public health for private enjoyment.
4. Provide additional limitations and transparency in the exemption process to ensure any project found exempt for infeasibility is truly in the public interest. I'm concerned about the news of powerful and connected people being able to get favors from DBI. We need sunshine on the exemption process, and exemptions should only be given in the public interest.
5. Amend section 106A.1.17 to require that the Building Official find "sufficient evidence was submitted to substantiate the infeasibility of an All-Electric Building or Project design without regard to financial, floor-area, or amenity-related loss unless deemed to be in the public welfare. The housing crisis is real. And we need to find ways of fixing it without sacrificing our children's future. The space taken up by a transformer should not be an acceptable reason for an exemption.

6. Eliminate the blanket exemption for commercial kitchens delaying compliance until 2022. Existing restaurants are not helped by giving builders a pass on making future commercial kitchens all-electric.

Thank you for taking up this important issue and considering the health and safety of our residents and climate.

Adrienne Gembala
adriennegembala@gmail.com
1617 Fulton Street
San Francisco, California 94117

From: [Jacob Hurwitz](#)
To: [Major, Erica \(BOS\)](#); [Board of Supervisors, \(BOS\)](#); [Preston, Dean \(BOS\)](#); [Peskin, Aaron \(BOS\)](#); [Safai, Ahsha \(BOS\)](#); [MandelmanStaff, \(BOS\)](#); [Ronen, Hillary](#)
Subject: Public Comment Re: BoS File 200701
Date: Wednesday, September 16, 2020 10:53:22 PM

This message is from outside the City email system. Do not open links or attachments from untrusted sources.

Land Use Committee, Board of Supervisors, and Sup. Ronen,

I'm a resident of San Francisco (D9) writing to strongly support prohibiting gas in new construction. The methane leaks, air pollution, and explosion dangers of natural gas are no longer necessary for the functioning of our homes and businesses. San Francisco can lead the state and the country in building a better future.

In addition to recommending the ordinance, I would also like to ask the Commission to recommend the changes to the ordinance as laid out by Earthjustice, the Sierra Club, the San Francisco Climate Emergency Coalition, and other local groups in their letter to the Commission and Board.

It is important to me that we:

1. Eliminate the feasibility exception to the electric-ready requirement and make fully electric-ready construction a baseline requirement for new construction. We know that the future is electric. Allowing any building to be built that will require massive retrofits in the near future is unacceptable. With full electric readiness, we minimize that retrofit cost.
2. Create a Clean Energy Building Hub through the City and County of San Francisco that provides for the outreach, resources, and education needed to eliminate barriers and maximize opportunity for all-electric new construction to benefit both climate and equity.
3. Expand the ordinance's definition of "mixed-fuel buildings" to include laboratory, industrial, and decorative uses of gas. Gas shouldn't be allowed for upscale decorative uses. It's wrong to harm public health for private enjoyment.
4. Provide additional limitations and transparency in the exemption process to ensure any project found exempt for infeasibility is truly in the public interest. I'm concerned about the news of powerful and connected people being able to get favors from DBI. We need sunshine on the exemption process, and exemptions should only be given in the public interest.
5. Amend section 106A.1.17 to require that the Building Official find "sufficient evidence was submitted to substantiate the infeasibility of an All-Electric Building or Project design without regard to financial, floor-area, or amenity-related loss unless deemed to be in the public welfare." The housing crisis is real. And we need to find ways of fixing it without sacrificing our children's future. The space taken up by a transformer should not be an acceptable reason for

an exemption.

6. Eliminate the blanket exemption for commercial kitchens delaying compliance until 2022. Existing restaurants are not helped by giving builders a pass on making future commercial kitchens all-electric.

Thank you for taking up this important issue and considering the health and safety of our residents and climate.

Jacob Hurwitz
jacobhurwitz@gmail.com
3228 22nd St
San Francisco, California 94110

From: [Joyce Calagos](#)
To: [Major, Erica \(BOS\)](#); [Board of Supervisors, \(BOS\)](#); [Preston, Dean \(BOS\)](#); [Peskin, Aaron \(BOS\)](#); [Safai, Ahsha \(BOS\)](#); [MandelmanStaff, \[BOS\]](#)
Subject: Public Comment Re: BoS File 200701
Date: Thursday, September 17, 2020 7:22:40 AM

This message is from outside the City email system. Do not open links or attachments from untrusted sources.

Land Use Committee, Board of Supervisors, and Sup. Safai,

I'm a resident of San Francisco since 1948! I live in District 11 where my supervisor is Ahsha Safai.

As the very first non-canonically professed Lay Promoter for Justice, Peace and Care of Creation of the Western Dominican Province of the Most Holy Name of Jesus, and as a member of Senior Disability Action, I am writing to urge you to strongly support the ordinance that would ban gas and use only earth-friendly, energy-saving electricity in construction.

Let San Francisco lead our State, our country, and the entire world in caring for creation by adopting this ordinance.

The methane leaks, air pollution, and explosion dangers of natural gas are no longer necessary for the functioning of our homes and businesses.

In addition to recommending the ordinance, I would also like to ask the Commission to recommend the changes to the ordinance as laid out by EarthJustice, the Sierra Club, the San Francisco Climate Emergency Coalition, and other local groups in their letter to the Commission and Board.

It is important to me that we:

1. Eliminate the feasibility exception to the electric-ready requirement and make fully electric-ready construction a baseline requirement for new construction. We know that the future is electric. Allowing any building to be built that will require massive retrofits in the near future is unacceptable. With full electric readiness, we minimize that retrofit cost.
2. Create a Clean Energy Building Hub through the City and County of San Francisco that provides for the outreach, resources, and education needed to eliminate barriers and maximize opportunity for all-electric new construction to benefit both climate and equity.
3. Expand the ordinance's definition of "mixed-fuel buildings" to include laboratory, industrial, and decorative uses of gas. Gas shouldn't be allowed for upscale decorative uses. It's wrong to harm public health for private enjoyment.
4. Provide additional limitations and transparency in the exemption process to ensure any project found exempt for infeasibility is truly in the public interest. I'm concerned about the

news of powerful and connected people being able to get favors from DBI. We need sunshine on the exemption process, and exemptions should only be given in the public interest.

5. Amend section 106A.1.17 to require that the Building Official find "sufficient evidence was submitted to substantiate the infeasibility of an All-Electric Building or Project design without regard to financial, floor-area, or amenity-related loss unless deemed to be in the public welfare." The housing crisis is real. And we need to find ways of fixing it without sacrificing our children's future. The space taken up by a transformer should not be an acceptable reason for an exemption.

6. Eliminate the blanket exemption for commercial kitchens delaying compliance until 2022. Existing restaurants are not helped by giving builders a pass on making future commercial kitchens all-electric.

Thank you for taking up this important issue and considering the health and safety of our residents and climate.

Joyce Calagos
joycecalagos1@gmail.com
1636 Geneva Ave.
San Francisco, California 94134

From: [Cherie Salonga](#)
To: [Major, Erica \(BOS\)](#); [Board of Supervisors, \(BOS\)](#); [Preston, Dean \(BOS\)](#); [Peskin, Aaron \(BOS\)](#); [Safai, Ahsha \(BOS\)](#); [MandelmanStaff, \(BOS\)](#); [Mar, Gordon \(BOS\)](#)
Subject: Public Comment Re: BoS File 200701
Date: Thursday, September 17, 2020 10:15:57 AM

This message is from outside the City email system. Do not open links or attachments from untrusted sources.

Land Use Committee, Board of Supervisors, and Sup. Mar,

I'm a resident of San Francisco writing to strongly support prohibiting gas in new construction. The methane leaks, air pollution, and explosion dangers of natural gas are no longer necessary for the functioning of our homes and businesses. San Francisco can lead the state and the country in building a better future.

In addition to recommending the ordinance, I would also like to ask the Commission to recommend the changes to the ordinance as laid out by Earthjustice, the Sierra Club, the San Francisco Climate Emergency Coalition, and other local groups in their letter to the Commission and Board.

It is important to me that we:

1. Eliminate the feasibility exception to the electric-ready requirement and make fully electric-ready construction a baseline requirement for new construction. We know that the future is electric. Allowing any building to be built that will require massive retrofits in the near future is unacceptable. With full electric readiness, we minimize that retrofit cost.
2. Create a Clean Energy Building Hub through the City and County of San Francisco that provides for the outreach, resources, and education needed to eliminate barriers and maximize opportunity for all-electric new construction to benefit both climate and equity.
3. Expand the ordinance's definition of "mixed-fuel buildings" to include laboratory, industrial, and decorative uses of gas. Gas shouldn't be allowed for upscale decorative uses. It's wrong to harm public health for private enjoyment.
4. Provide additional limitations and transparency in the exemption process to ensure any project found exempt for infeasibility is truly in the public interest. I'm concerned about the news of powerful and connected people being able to get favors from DBI. We need sunshine on the exemption process, and exemptions should only be given in the public interest.
5. Amend section 106A.1.17 to require that the Building Official find "sufficient evidence was submitted to substantiate the infeasibility of an All-Electric Building or Project design without regard to financial, floor-area, or amenity-related loss unless deemed to be in the public welfare." The housing crisis is real. And we need to find ways of fixing it without sacrificing our children's future. The space taken up by a transformer should not be an acceptable reason for

an exemption.

6. Eliminate the blanket exemption for commercial kitchens delaying compliance until 2022. Existing restaurants are not helped by giving builders a pass on making future commercial kitchens all-electric.

Thank you for taking up this important issue and considering the health and safety of our residents and climate.

Cherie Salonga
cherie.salonga@gmail.com
1401 43rd Avenue
San Francisco, California 94122

From: [Brittany Schiro](#)
To: [Major, Erica \(BOS\)](#)
Cc: [Board of Supervisors \(BOS\)](#); [Preston, Dean \(BOS\)](#); [Peskin, Aaron \(BOS\)](#); [Safai, Ahsha \(BOS\)](#)
Subject: Public Comment Re: BoS File 200701
Date: Thursday, September 17, 2020 10:30:28 AM

This message is from outside the City email system. Do not open links or attachments from untrusted sources.

To whom it may concern,

I'm a resident of San Francisco writing to strongly support prohibiting gas in new construction. The methane leaks, air pollution, and explosion dangers of natural gas are no longer necessary for the functioning of our homes and businesses. San Francisco can lead the state and the country in building a better future.

In addition to recommending the ordinance, I would also like to ask the Commission to recommend the changes to the ordinance as laid out by Earthjustice, the Sierra Club, the San Francisco Climate Emergency Coalition, and other local groups in their letter to the Commission and Board.

It is important to me that we:

1. Eliminate the feasibility exception to the electric-ready requirement and make fully electric-ready construction a baseline requirement for new construction. We know that the future is electric. Allowing any building to be built that will require massive retrofits in the near future is unacceptable. With full electric readiness, we minimize that retrofit cost.
2. Create a Clean Energy Building Hub through the City and County of San Francisco that provides for the outreach, resources, and education needed to eliminate barriers and maximize opportunity for all-electric new construction to benefit both climate and equity.
3. Expand the ordinance's definition of "mixed-fuel buildings" to include laboratory, industrial, and decorative uses of gas. Gas shouldn't be allowed for upscale decorative uses. It's wrong to harm public health for private enjoyment.
4. Provide additional limitations and transparency in the exemption process to ensure any project found exempt for infeasibility is truly in the public interest. I'm concerned about the news of powerful and connected people being able to get favors from DBI. We need sunshine on the exemption process, and exemptions should only be given in the public interest.
5. Amend section 106A.1.17 to require that the Building Official find "sufficient evidence was submitted to substantiate the infeasibility of an All-Electric Building or

Project design without regard to financial, floor-area, or amenity-related loss unless deemed to be in the public welfare." The housing crisis is real. And we need to find ways of fixing it without sacrificing our children's future. The space taken up by a transformer should not be an acceptable reason for an exemption.

6. Eliminate the blanket exemption for commercial kitchens delaying compliance until 2022. Existing restaurants are not helped by giving builders a pass on making future commercial kitchens all-electric.

Thank you for taking up this important issue and considering the health and safety of our residents and climate.

Sincerely,

Brittany Schiro

San Francisco Resident

From: [Daniel Tahara](#)
To: [Major, Erica \(BOS\)](#); [Board of Supervisors, \(BOS\)](#); [Preston, Dean \(BOS\)](#); [Peskin, Aaron \(BOS\)](#); [Safai, Ahsha \(BOS\)](#); [MandelmanStaff, \[BOS\]](#)
Subject: Public Comment Re: BoS File 200701
Date: Thursday, September 17, 2020 10:36:40 AM

This message is from outside the City email system. Do not open links or attachments from untrusted sources.

Land Use Committee, Board of Supervisors, and Sup. Mandelman,

I'm a resident of San Francisco writing to strongly support prohibiting gas in new construction. The methane leaks, air pollution, and explosion dangers of natural gas are no longer necessary for the functioning of our homes and businesses. San Francisco can lead the state and the country in building a better future.

In addition to recommending the ordinance, I would also like to ask the Commission to recommend the changes to the ordinance as laid out by Earthjustice, the Sierra Club, the San Francisco Climate Emergency Coalition, and other local groups in their letter to the Commission and Board.

It is important to me that we:

1. Eliminate the feasibility exception to the electric-ready requirement and make fully electric-ready construction a baseline requirement for new construction. We know that the future is electric. Allowing any building to be built that will require massive retrofits in the near future is unacceptable. With full electric readiness, we minimize that retrofit cost.
2. Create a Clean Energy Building Hub through the City and County of San Francisco that provides for the outreach, resources, and education needed to eliminate barriers and maximize opportunity for all-electric new construction to benefit both climate and equity.
3. Expand the ordinance's definition of "mixed-fuel buildings" to include laboratory, industrial, and decorative uses of gas. Gas shouldn't be allowed for upscale decorative uses. It's wrong to harm public health for private enjoyment.
4. Provide additional limitations and transparency in the exemption process to ensure any project found exempt for infeasibility is truly in the public interest. I'm concerned about the news of powerful and connected people being able to get favors from DBI. We need sunshine on the exemption process, and exemptions should only be given in the public interest.
5. Amend section 106A.1.17 to require that the Building Official find "sufficient evidence was submitted to substantiate the infeasibility of an All-Electric Building or Project design without regard to financial, floor-area, or amenity-related loss unless deemed to be in the public welfare." The housing crisis is real. And we need to find ways of fixing it without sacrificing our children's future. The space taken up by a transformer should not be an acceptable reason for

an exemption.

6. Eliminate the blanket exemption for commercial kitchens delaying compliance until 2022. Existing restaurants are not helped by giving builders a pass on making future commercial kitchens all-electric.

Thank you for taking up this important issue and considering the health and safety of our residents and climate.

Daniel Tahara
dktahara@gmail.com
466 14th St
San Francisco, California 94103

From: [Barbara Jue](#)
To: [Major, Erica \(BOS\)](#); [Board of Supervisors, \(BOS\)](#); [Preston, Dean \(BOS\)](#); [Peskin, Aaron \(BOS\)](#); [Safai, Ahsha \(BOS\)](#); [MandelmanStaff, \(BOS\)](#); [Haney, Matt \(BOS\)](#)
Subject: Public Comment Re: BoS File 200701
Date: Thursday, September 17, 2020 10:52:00 AM

This message is from outside the City email system. Do not open links or attachments from untrusted sources.

Land Use Committee, Board of Supervisors, and Sup. Haney,

I'm a resident of San Francisco writing to strongly support prohibiting gas in new construction. The methane leaks, air pollution, and explosion dangers of natural gas are no longer necessary for the functioning of our homes and businesses. Indeed these dangers are exacerbated in an area susceptible to earthquakes.

My particular neighborhood, The East Cut, is filled with recently constructed high-density housing much of which has been equipped with gas kitchens. There has been so much new gas infrastructure to support this development, and the resulting emissions along with the threats listed above put my neighborhood at risk. It certainly doesn't make me feel safe.

Therefore it is important to me that we make the following changes to the ordinance:

1. Eliminate the feasibility exception to the electric-ready requirement and make fully electric-ready construction a baseline requirement for new construction. We know that the future is electric. Allowing any building to be built that will require massive retrofits in the near future is unacceptable. With full electric readiness, we minimize that retrofit cost.
2. Create a Clean Energy Building Hub through the City and County of San Francisco that provides for the outreach, resources, and education needed to eliminate barriers and maximize opportunity for all-electric new construction to benefit both climate and equity.
3. Provide additional limitations and transparency in the exemption process to ensure any project found exempt for infeasibility is truly in the public interest. I'm concerned about the news of powerful and connected people being able to get favors from DBI. We need sunshine on the exemption process, and exemptions should only be given in the public interest.
4. Eliminate the blanket exemption for commercial kitchens delaying compliance until 2022. There is no reason why new kitchens cannot be all-electric going forward.

Thank you for taking up this important issue and considering the health and safety of our residents and climate.

Barbara Jue
sfbar48@gmail.com
81 Lansing Street, #411

San Francisco, California 94105

From: [Charles Whitfield](#)
To: [Major, Erica \(BOS\)](#); [Board of Supervisors, \(BOS\)](#); [Preston, Dean \(BOS\)](#); [Peskin, Aaron \(BOS\)](#); [Safai, Ahsha \(BOS\)](#); [MandelmanStaff, \[BOS\]](#)
Subject: Public Comment Re: BoS File 200701 (Item 1 of 9/21 Land Use)
Date: Thursday, September 17, 2020 11:37:36 AM

This message is from outside the City email system. Do not open links or attachments from untrusted sources.

Land Use Committee, Board of Supervisors, and Sup. Mandelman,

I'm a resident of San Francisco writing to strongly support prohibiting gas in new construction. The methane leaks, air pollution, and explosion dangers of natural gas are no longer necessary for the functioning of our homes and businesses. San Francisco can lead the state and the country in building a better future.

In addition to recommending the ordinance, I would also like to ask the Commission to recommend the changes to the ordinance as laid out by Earthjustice, the Sierra Club, the San Francisco Climate Emergency Coalition, and other local groups in their letter to the Commission and Board.

It is important to me that we:

1. Eliminate the feasibility exception to the electric-ready requirement and make fully electric-ready construction a baseline requirement for new construction. We know that the future is electric. Allowing any building to be built that will require massive retrofits in the near future is unacceptable. With full electric readiness, we minimize that retrofit cost.
2. Create a Clean Energy Building Hub through the City and County of San Francisco that provides for the outreach, resources, and education needed to eliminate barriers and maximize opportunity for all-electric new construction to benefit both climate and equity.
3. Expand the ordinance's definition of "mixed-fuel buildings" to include laboratory, industrial, and decorative uses of gas. Gas shouldn't be allowed for upscale decorative uses. It's wrong to harm public health for private enjoyment.
4. Provide additional limitations and transparency in the exemption process to ensure any project found exempt for infeasibility is truly in the public interest. I'm concerned about the news of powerful and connected people being able to get favors from DBI. We need sunshine on the exemption process, and exemptions should only be given in the public interest.
5. Amend section 106A.1.17 to require that the Building Official find "sufficient evidence was submitted to substantiate the infeasibility of an All-Electric Building or Project design without regard to financial, floor-area, or amenity-related loss unless deemed to be in the public welfare." The housing crisis is real. And we need to find ways of fixing it without sacrificing our children's future. The space taken up by a transformer should not be an acceptable reason for

an exemption.

6. Eliminate the blanket exemption for commercial kitchens delaying compliance until 2022. Existing restaurants are not helped by giving builders a pass on making future commercial kitchens all-electric.

Thank you for taking up this important issue and considering the health and safety of our residents and climate.

Charles Whitfield
whitfield.cw@gmail.com
233 Eureka Street
San Francisco, California 94114

From: [NIDHI KALRA](#)
To: [Major, Erica \(BOS\)](#); [Board of Supervisors, \(BOS\)](#); [Preston, Dean \(BOS\)](#); [Peskin, Aaron \(BOS\)](#); [Safai, Ahsha \(BOS\)](#); [MandelmanStaff, \[BOS\]](#)
Subject: Public Comment Re: BoS File 200701 (Item 1 of 9/21 Land Use)
Date: Thursday, September 17, 2020 12:01:10 PM

This message is from outside the City email system. Do not open links or attachments from untrusted sources.

Land Use Committee, Board of Supervisors, and Sup. Mandelman,

I'm a resident of San Francisco writing to strongly support prohibiting gas in new construction. The methane leaks, air pollution, and explosion dangers of natural gas are no longer necessary for the functioning of our homes and businesses. San Francisco can lead the state and the country in building a better future.

In addition to recommending the ordinance, I would also like to ask the Commission to recommend the changes to the ordinance as laid out by Earthjustice, the Sierra Club, the San Francisco Climate Emergency Coalition, and other local groups in their letter to the Commission and Board.

It is important to me that we:

1. Eliminate the feasibility exception to the electric-ready requirement and make fully electric-ready construction a baseline requirement for new construction. We know that the future is electric. Allowing any building to be built that will require massive retrofits in the near future is unacceptable. With full electric readiness, we minimize that retrofit cost.
2. Create a Clean Energy Building Hub through the City and County of San Francisco that provides for the outreach, resources, and education needed to eliminate barriers and maximize opportunity for all-electric new construction to benefit both climate and equity.
3. Expand the ordinance's definition of "mixed-fuel buildings" to include laboratory, industrial, and decorative uses of gas. Gas shouldn't be allowed for upscale decorative uses. It's wrong to harm public health for private enjoyment.
4. Provide additional limitations and transparency in the exemption process to ensure any project found exempt for infeasibility is truly in the public interest. I'm concerned about the news of powerful and connected people being able to get favors from DBI. We need sunshine on the exemption process, and exemptions should only be given in the public interest.
5. Amend section 106A.1.17 to require that the Building Official find "sufficient evidence was submitted to substantiate the infeasibility of an All-Electric Building or Project design without regard to financial, floor-area, or amenity-related loss unless deemed to be in the public welfare." The housing crisis is real. And we need to find ways of fixing it without sacrificing our children's future. The space taken up by a transformer should not be an acceptable reason for

an exemption.

6. Eliminate the blanket exemption for commercial kitchens delaying compliance until 2022. Existing restaurants are not helped by giving builders a pass on making future commercial kitchens all-electric.

Thank you for taking up this important issue and considering the health and safety of our residents and climate.

NIDHI KALRA

nidhi.r.kalra@gmail.com

4039 26th St.

San Francisco, California 94131

From: [Danielle Maybach](#)
To: [Major, Erica \(BOS\)](#); [Board of Supervisors, \(BOS\)](#); [Preston, Dean \(BOS\)](#); [Peskin, Aaron \(BOS\)](#); [Safai, Ahsha \(BOS\)](#); [MandelmanStaff, \(BOS\)](#); [Stefani, Catherine \(BOS\)](#)
Subject: Public Comment Re: BoS File 200701 (Item 1 of 9/21 Land Use)
Date: Thursday, September 17, 2020 12:23:17 PM

This message is from outside the City email system. Do not open links or attachments from untrusted sources.

Land Use Committee, Board of Supervisors, and Sup. Stefani,

I'm a resident of San Francisco writing to strongly support prohibiting gas in new construction. The methane leaks, air pollution, and explosion dangers of natural gas are no longer necessary for the functioning of our homes and businesses. San Francisco can lead the state and the country in building a better future.

In addition to recommending the ordinance, I would also like to ask the Commission to recommend the changes to the ordinance as laid out by Earthjustice, the Sierra Club, the San Francisco Climate Emergency Coalition, and other local groups in their letter to the Commission and Board.

It is important to me that we:

1. Eliminate the feasibility exception to the electric-ready requirement and make fully electric-ready construction a baseline requirement for new construction. We know that the future is electric. Allowing any building to be built that will require massive retrofits in the near future is unacceptable. With full electric readiness, we minimize that retrofit cost.
2. Create a Clean Energy Building Hub through the City and County of San Francisco that provides for the outreach, resources, and education needed to eliminate barriers and maximize opportunity for all-electric new construction to benefit both climate and equity.
3. Expand the ordinance's definition of "mixed-fuel buildings" to include laboratory, industrial, and decorative uses of gas. Gas shouldn't be allowed for upscale decorative uses. It's wrong to harm public health for private enjoyment.
4. Provide additional limitations and transparency in the exemption process to ensure any project found exempt for infeasibility is truly in the public interest. I'm concerned about the news of powerful and connected people being able to get favors from DBI. We need sunshine on the exemption process, and exemptions should only be given in the public interest.
5. Amend section 106A.1.17 to require that the Building Official find "sufficient evidence was submitted to substantiate the infeasibility of an All-Electric Building or Project design without regard to financial, floor-area, or amenity-related loss unless deemed to be in the public welfare." The housing crisis is real. And we need to find ways of fixing it without sacrificing our children's future. The space taken up by a transformer should not be an acceptable reason for

an exemption.

6. Eliminate the blanket exemption for commercial kitchens delaying compliance until 2022. Existing restaurants are not helped by giving builders a pass on making future commercial kitchens all-electric.

Thank you for taking up this important issue and considering the health and safety of our residents and climate.

Danielle Maybach
danielle.maybach@gmail.com
3106 Fillmore Street, Second Floor
San Francisco, California 94123

From: [C. Homsey](#)
To: [Major, Erica \(BOS\)](#)
Cc: [Peskin, Aaron \(BOS\)](#); [Safai, Ahsha \(BOS\)](#); [Board of Supervisors, \(BOS\)](#); [Preston, Dean \(BOS\)](#); [Yee, Norman \(BOS\)](#)
Subject: Public Comment Re: BoS File 200701
Date: Thursday, September 17, 2020 1:12:37 PM

This message is from outside the City email system. Do not open links or attachments from untrusted sources.

Dear Ms. Major,

I'm a resident of San Francisco writing to strongly support prohibiting gas in new construction. The methane leaks, air pollution, and explosion dangers of natural gas are no longer necessary for the functioning of our homes and businesses. San Francisco can lead the state and the country in building a better future.

In addition to recommending the ordinance, I would also like to ask the Commission to recommend the changes to the ordinance as laid out by Earthjustice, the Sierra Club, the San Francisco Climate Emergency Coalition, and other local groups in their letter to the Commission and Board.

It is important to me that we:

1. Eliminate the feasibility exception to the electric-ready requirement and make fully electric-ready construction a baseline requirement for new construction. We know that the future is electric. Allowing any building to be built that will require massive retrofits in the near future is unacceptable. With full electric readiness, we minimize that retrofit cost.
2. Create a Clean Energy Building Hub through the City and County of San Francisco that provides for the outreach, resources, and education needed to eliminate barriers and maximize opportunity for all-electric new construction to benefit both climate and equity.
3. Expand the ordinance's definition of "mixed-fuel buildings" to include laboratory, industrial, and decorative uses of gas. Gas shouldn't be allowed for upscale decorative uses. It's wrong to harm public health for private enjoyment.
4. Provide additional limitations and transparency in the exemption process to ensure any project found exempt for infeasibility is truly in the public interest. I'm concerned about the news of powerful and connected people being able to get favors from DBI. We need sunshine on the exemption process, and exemptions should only be given in the public interest.
5. Amend section 106A.1.17 to require that the Building Official find "sufficient evidence was submitted to substantiate the infeasibility of an All-Electric Building or Project design without regard to financial, floor-area, or amenity-related loss unless

deemed to be in the public welfare." The housing crisis is real. And we need to find ways of fixing it without sacrificing our children's future. The space taken up by a transformer should not be an acceptable reason for an exemption.

6. Eliminate the blanket exemption for commercial kitchens delaying compliance until 2022. Existing restaurants are not helped by giving builders a pass on making future commercial kitchens all-electric.

Thank you for taking up this important issue and considering the health and safety of our residents and climate.

Sincerely,

Catherine Homsey
140 Bella Vista Way
San Francisco, CA 94127

--

Catherine Homsey
415.608.3181
joyofzerowaste.com
Instagram & Facebook @joyofzerowaste

From: [Arman Khatchatrian](#)
To: [Major, Erica \(BOS\)](#)
Subject: Balboa Reservoir Project Case #s: 200422 (SUD), 200635 (General Plan), 200423 (Development Agreement) and 200740 (Purchase and Sale Agreement)
Date: Monday, July 20, 2020 9:22:56 AM

This message is from outside the City email system. Do not open links or attachments from untrusted sources.

Erica Major,

My name is Arman Khatchatrian and I live in the Glen Park neighborhood. I have been participating in the community planning process for the Balboa Reservoir and am writing in support of the development proposal being reviewed by the Land Use Committee and on July 27, 2020 and Budget and Finance Committee on July 29, 2020.

Living in San Francisco, we have an opportunity to reduce our reliance on automobiles in order to reduce greenhouse gas emissions, slow global warming, and reduce automobile congestion in our neighborhoods. This can only be done by encouraging residents to use car-alternatives for getting around our City, whether by walking, biking, and using public transit and minimizing private auto trips. The Reservoir Partners development proposal of 1,100 homes is designed to provide new residents access to modes of transportation that will reduce residents' reliance on cars. The multiple direct pedestrian connections to Ocean Avenue and transit, the new protected bike lanes, bike share docking stations, and bicycle parking all allow people to get around the neighborhood without a car. Car share parking pods and memberships will provide residents with auto options, but along with the unbundled parking associated with the apartments, will help decrease car ownership rates.

In terms of neighborhood transit improvements, the Reservoir development's lengthy planning process and the development's contribution of approximately \$10mil for Transportation Sustainability Fees is spurring improvements along Ocean Avenue planned by SFMTA, the Planning Department, and CCSF. As described in their 4/27/20 Community Advisory Committee presentation, SFMTA is proposing to improve the safety and usability of the Geneva/Ocean Avenue intersection as well as west along Ocean Avenue and to reduce delays along the K, 43, and 29 MUNI lines. CCSF is working with the City to significantly increase the width of the sidewalk along the campus frontage from Frida Kahlo Way east towards the BART and MUNI stations. All of these improvements, and more, will help support the City's Vision Zero plan for Ocean Avenue, making it safer for Ocean Avenue's pedestrians, transit riders, and car drivers, neighbors and shoppers alike. Please support this project.

Arman Khatchatrian
armank0089@gmail.com
124 Bemis St.
San Francisco, California 94131

From: [kathie.piccagli](#)
To: [Major, Erica \(BOS\)](#); [Board of Supervisors, \(BOS\)](#); [Preston, Dean \(BOS\)](#); [Peskin, Aaron \(BOS\)](#); [Safai, Ahsha \(BOS\)](#); [Yee, Norman \(BOS\)](#)
Subject: Public Comment Re: BoS File 200701
Date: Wednesday, September 16, 2020 11:55:21 AM

This message is from outside the City email system. Do not open links or attachments from untrusted sources.

Land Use Committee, Board of Supervisors, and Sup. Yee,

I'm a resident of San Francisco writing to strongly support prohibiting gas in new construction. The methane leaks, air pollution, and explosion dangers of natural gas are no longer necessary for the functioning of our homes and businesses. San Francisco can lead the state and the country in building a better future.

In addition to recommending the ordinance, I would also like to ask the Commission to recommend the changes to the ordinance as laid out by Earthjustice, the Sierra Club, the San Francisco Climate Emergency Coalition, and other local groups in their letter to the Commission and Board.

It is important to me that we:

1. Eliminate the feasibility exception to the electric-ready requirement and make fully electric-ready construction a baseline requirement for new construction. We know that the future is electric. Allowing any building to be built that will require massive retrofits in the near future is unacceptable. With full electric readiness, we minimize that retrofit cost.
2. Create a Clean Energy Building Hub through the City and County of San Francisco that provides for the outreach, resources, and education needed to eliminate barriers and maximize opportunity for all-electric new construction to benefit both climate and equity.
3. Expand the ordinance's definition of "mixed-fuel buildings" to include laboratory, industrial, and decorative uses of gas. Gas shouldn't be allowed for upscale decorative uses. It's wrong to harm public health for private enjoyment.
4. Provide additional limitations and transparency in the exemption process to ensure any project found exempt for infeasibility is truly in the public interest. I'm concerned about the news of powerful and connected people being able to get favors from DBI. We need sunshine on the exemption process, and exemptions should only be given in the public interest.
5. Amend section 106A.1.17 to require that the Building Official find "sufficient evidence was submitted to substantiate the infeasibility of an All-Electric Building or Project design without regard to financial, floor-area, or amenity-related loss unless deemed to be in the public welfare. The housing crisis is real. And we need to find ways of fixing it without sacrificing our children's future. The space taken up by a transformer should not be an acceptable reason for

an exemption.

6. Eliminate the blanket exemption for commercial kitchens delaying compliance until 2022. Existing restaurants are not helped by giving builders a pass on making future commercial kitchens all-electric.

Thank you for taking up this important issue and considering the health and safety of our residents and climate.

kathie piccagli
kpiccagli@gmail.com
100 Dorado Terrace
san francisco, California 94112

From: [Jill Stanton](#)
To: [Major, Erica \(BOS\)](#); [Board of Supervisors, \(BOS\)](#); [Preston, Dean \(BOS\)](#); [Peskin, Aaron \(BOS\)](#); [Safai, Ahsha \(BOS\)](#); [Ronen, Hillary](#)
Subject: Public Comment Re: BoS File 200701
Date: Wednesday, September 16, 2020 4:30:17 PM

This message is from outside the City email system. Do not open links or attachments from untrusted sources.

Land Use Committee, Board of Supervisors, and Sup. Ronen,

I'm a resident of San Francisco writing to strongly support prohibiting gas in new construction. The methane leaks, air pollution, and explosion dangers of natural gas are no longer necessary for the functioning of our homes and businesses. San Francisco can lead the state and the country in building a better future.

In addition to recommending the ordinance, I would also like to ask the Commission to recommend the changes to the ordinance as laid out by Earthjustice, the Sierra Club, the San Francisco Climate Emergency Coalition, and other local groups in their letter to the Commission and Board.

It is important to me that we:

1. Eliminate the feasibility exception to the electric-ready requirement and make fully electric-ready construction a baseline requirement for new construction. We know that the future is electric. Allowing any building to be built that will require massive retrofits in the near future is unacceptable. With full electric readiness, we minimize that retrofit cost.
2. Create a Clean Energy Building Hub through the City and County of San Francisco that provides for the outreach, resources, and education needed to eliminate barriers and maximize opportunity for all-electric new construction to benefit both climate and equity.
3. Expand the ordinance's definition of "mixed-fuel buildings" to include laboratory, industrial, and decorative uses of gas. Gas shouldn't be allowed for upscale decorative uses. It's wrong to harm public health for private enjoyment.
4. Provide additional limitations and transparency in the exemption process to ensure any project found exempt for infeasibility is truly in the public interest. I'm concerned about the news of powerful and connected people being able to get favors from DBI. We need sunshine on the exemption process, and exemptions should only be given in the public interest.
5. Amend section 106A.1.17 to require that the Building Official find "sufficient evidence was submitted to substantiate the infeasibility of an All-Electric Building or Project design without regard to financial, floor-area, or amenity-related loss unless deemed to be in the public welfare. The housing crisis is real. And we need to find ways of fixing it without sacrificing our children's future. The space taken up by a transformer should not be an acceptable reason for

an exemption.

6. Eliminate the blanket exemption for commercial kitchens delaying compliance until 2022. Existing restaurants are not helped by giving builders a pass on making future commercial kitchens all-electric.

Thank you for taking up this important issue and considering the health and safety of our residents and climate.

Jill Stanton

jillstanton9@gmail.com

415 Franconia St

San Francisco, California 94110-5735

From: [Nick Reavill](#)
To: [Major, Erica \(BOS\)](#); [Board of Supervisors, \(BOS\)](#); [Preston, Dean \(BOS\)](#); [Peskin, Aaron \(BOS\)](#); [Safai, Ahsha \(BOS\)](#); [Ronen, Hillary](#)
Subject: Public Comment Re: BoS File 200701
Date: Wednesday, September 16, 2020 5:49:54 PM

This message is from outside the City email system. Do not open links or attachments from untrusted sources.

Land Use Committee, Board of Supervisors, and Sup. Ronen,

I'm a resident of San Francisco and constituent of Supervisor Ronen writing to strongly support prohibiting gas in new construction. The methane leaks, air pollution, and explosion dangers of natural gas are no longer necessary for the functioning of our homes and businesses. San Francisco can lead the state and the country in building a better future.

If we are going to fully electrify the economy, which we must to fight the climate crisis, this change to our building codes will have to happen eventually. Why not now, to give people in effected industries a chance to transition (hopefully with support from government).

In addition to recommending the ordinance, I would also like to ask the Commission to recommend the changes to the ordinance as laid out by Earthjustice, the Sierra Club, the San Francisco Climate Emergency Coalition, and other local groups in their letter to the Commission and Board.

It is important to me that we:

1. Eliminate the feasibility exception to the electric-ready requirement and make fully electric-ready construction a baseline requirement for new construction. We know that the future is electric. Allowing any building to be built that will require massive retrofits in the near future is unacceptable. With full electric readiness, we minimize that retrofit cost.
2. Create a Clean Energy Building Hub through the City and County of San Francisco that provides for the outreach, resources, and education needed to eliminate barriers and maximize opportunity for all-electric new construction to benefit both climate and equity.
3. Expand the ordinance's definition of "mixed-fuel buildings" to include laboratory, industrial, and decorative uses of gas. Gas shouldn't be allowed for upscale decorative uses. It's wrong to harm public health for private enjoyment.
4. Provide additional limitations and transparency in the exemption process to ensure any project found exempt for infeasibility is truly in the public interest. I'm concerned about the news of powerful and connected people being able to get favors from DBI. We need sunshine on the exemption process, and exemptions should only be given in the public interest.
5. Amend section 106A.1.17 to require that the Building Official find "sufficient evidence was

submitted to substantiate the infeasibility of an All-Electric Building or Project design without regard to financial, floor-area, or amenity-related loss unless deemed to be in the public welfare. The housing crisis is real. And we need to find ways of fixing it without sacrificing our children's future. The space taken up by a transformer should not be an acceptable reason for an exemption.

6. Eliminate the blanket exemption for commercial kitchens delaying compliance until 2022. Existing restaurants are not helped by giving builders a pass on making future commercial kitchens all-electric.

Thank you for taking up this important issue and considering the health and safety of our residents and climate.

Nick Reavill
nreavill@gmail.com
646 Felton St
San Francisco, California 94134

From: [kevin.meissner](#)
To: [Major, Erica \(BOS\)](#); [Board of Supervisors, \(BOS\)](#); [Preston, Dean \(BOS\)](#); [Peskin, Aaron \(BOS\)](#); [Safai, Ahsha \(BOS\)](#); [Ronen, Hillary](#)
Subject: Public Comment Re: BoS File 200701
Date: Wednesday, September 16, 2020 6:34:50 PM

This message is from outside the City email system. Do not open links or attachments from untrusted sources.

Land Use Committee, Board of Supervisors, and Sup. Ronen,

I'm a resident of San Francisco writing to strongly support prohibiting gas in new construction. The methane leaks, air pollution, and explosion dangers of natural gas are no longer necessary for the functioning of our homes and businesses. San Francisco can lead the state and the country in building a better future.

In addition to recommending the ordinance, I would also like to ask the Commission to recommend the changes to the ordinance as laid out by Earthjustice, the Sierra Club, the San Francisco Climate Emergency Coalition, and other local groups in their letter to the Commission and Board.

It is important to me that we:

1. Eliminate the feasibility exception to the electric-ready requirement and make fully electric-ready construction a baseline requirement for new construction. We know that the future is electric. Allowing any building to be built that will require massive retrofits in the near future is unacceptable. With full electric readiness, we minimize that retrofit cost.
2. Create a Clean Energy Building Hub through the City and County of San Francisco that provides for the outreach, resources, and education needed to eliminate barriers and maximize opportunity for all-electric new construction to benefit both climate and equity.
3. Expand the ordinance's definition of "mixed-fuel buildings" to include laboratory, industrial, and decorative uses of gas. Gas shouldn't be allowed for upscale decorative uses. It's wrong to harm public health for private enjoyment.
4. Provide additional limitations and transparency in the exemption process to ensure any project found exempt for infeasibility is truly in the public interest. I'm concerned about the news of powerful and connected people being able to get favors from DBI. We need sunshine on the exemption process, and exemptions should only be given in the public interest.
5. Amend section 106A.1.17 to require that the Building Official find "sufficient evidence was submitted to substantiate the infeasibility of an All-Electric Building or Project design without regard to financial, floor-area, or amenity-related loss unless deemed to be in the public welfare. The housing crisis is real. And we need to find ways of fixing it without sacrificing our children's future. The space taken up by a transformer should not be an acceptable reason for

an exemption.

6. Eliminate the blanket exemption for commercial kitchens delaying compliance until 2022. Existing restaurants are not helped by giving builders a pass on making future commercial kitchens all-electric.

Thank you for taking up this important issue and considering the health and safety of our residents and climate.

kevin meissner
chimere@gmail.com
1138 treat ave
san francisco, California 94110

From: [elliott helman](#)
To: [Major, Erica \(BOS\)](#); [Board of Supervisors, \(BOS\)](#); [Preston, Dean \(BOS\)](#); [Peskin, Aaron \(BOS\)](#); [Safai, Ahsha \(BOS\)](#); [Haney, Matt \(BOS\)](#)
Subject: Public Comment Re: BoS File 200701
Date: Wednesday, September 16, 2020 8:12:07 PM

This message is from outside the City email system. Do not open links or attachments from untrusted sources.

Land Use Committee, Board of Supervisors, and Sup. Haney,

I'm a resident of San Francisco writing to strongly support prohibiting gas in new construction. The methane leaks, air pollution, and explosion dangers of natural gas are no longer necessary for the functioning of our homes and businesses. San Francisco can lead the state and the country in building a better future.

In addition to recommending the ordinance, I would also like to ask the Commission to recommend the changes to the ordinance as laid out by Earthjustice, the Sierra Club, the San Francisco Climate Emergency Coalition, and other local groups in their letter to the Commission and Board.

It is important to me that we:

1. Eliminate the feasibility exception to the electric-ready requirement and make fully electric-ready construction a baseline requirement for new construction. We know that the future is electric. Allowing any building to be built that will require massive retrofits in the near future is unacceptable. With full electric readiness, we minimize that retrofit cost.
2. Create a Clean Energy Building Hub through the City and County of San Francisco that provides for the outreach, resources, and education needed to eliminate barriers and maximize opportunity for all-electric new construction to benefit both climate and equity.
3. Expand the ordinance's definition of "mixed-fuel buildings" to include laboratory, industrial, and decorative uses of gas. Gas shouldn't be allowed for upscale decorative uses. It's wrong to harm public health for private enjoyment.
4. Provide additional limitations and transparency in the exemption process to ensure any project found exempt for infeasibility is truly in the public interest. I'm concerned about the news of powerful and connected people being able to get favors from DBI. We need sunshine on the exemption process, and exemptions should only be given in the public interest.
5. Amend section 106A.1.17 to require that the Building Official find "sufficient evidence was submitted to substantiate the infeasibility of an All-Electric Building or Project design without regard to financial, floor-area, or amenity-related loss unless deemed to be in the public welfare. The housing crisis is real. And we need to find ways of fixing it without sacrificing our children's future. The space taken up by a transformer should not be an acceptable reason for

an exemption.

6. Eliminate the blanket exemption for commercial kitchens delaying compliance until 2022. Existing restaurants are not helped by giving builders a pass on making future commercial kitchens all-electric.

Thank you for taking up this important issue and considering the health and safety of our residents and climate.

elliot helman

muzungu_x@yahoo.com

626 mission bay blvd N #210

san francisco, California 94158-2497

From: [Maia Piccagli](#)
To: [Major, Erica \(BOS\)](#); [Board of Supervisors, \(BOS\)](#); [Preston, Dean \(BOS\)](#); [Peskin, Aaron \(BOS\)](#); [Safai, Ahsha \(BOS\)](#); [Ronen, Hillary](#)
Subject: Public Comment Re: BoS File 200701
Date: Wednesday, September 16, 2020 8:46:08 PM

This message is from outside the City email system. Do not open links or attachments from untrusted sources.

Land Use Committee, Board of Supervisors, and Sup. Ronen,

I'm a resident of San Francisco District 9, writing to strongly support prohibiting gas in new construction. The methane leaks, air pollution, and explosion dangers of natural gas are no longer necessary for the functioning of our homes and businesses. San Francisco can lead the state and the country in building a better future.

In addition to recommending the ordinance, I would also like to ask the Commission to recommend the changes to the ordinance as laid out by Earthjustice, the Sierra Club, the San Francisco Climate Emergency Coalition, and other local groups in their letter to the Commission and Board.

It is important to me that we:

1. Eliminate the feasibility exception to the electric-ready requirement and make fully electric-ready construction a baseline requirement for new construction. We know that the future is electric. Allowing any building to be built that will require massive retrofits in the near future is unacceptable. With full electric readiness, we minimize that retrofit cost.
2. Create a Clean Energy Building Hub through the City and County of San Francisco that provides for the outreach, resources, and education needed to eliminate barriers and maximize opportunity for all-electric new construction to benefit both climate and equity.
3. Expand the ordinance's definition of "mixed-fuel buildings" to include laboratory, industrial, and decorative uses of gas. Gas shouldn't be allowed for upscale decorative uses. It's wrong to harm public health for private enjoyment.
4. Provide additional limitations and transparency in the exemption process to ensure any project found exempt for infeasibility is truly in the public interest. I'm concerned about the news of powerful and connected people being able to get favors from DBI. We need sunshine on the exemption process, and exemptions should only be given in the public interest.
5. Amend section 106A.1.17 to require that the Building Official find "sufficient evidence was submitted to substantiate the infeasibility of an All-Electric Building or Project design without regard to financial, floor-area, or amenity-related loss unless deemed to be in the public welfare. The housing crisis is real. And we need to find ways of fixing it without sacrificing our children's future. The space taken up by a transformer should not be an acceptable reason for

an exemption.

6. Eliminate the blanket exemption for commercial kitchens delaying compliance until 2022. Existing restaurants are not helped by giving builders a pass on making future commercial kitchens all-electric.

Thank you for taking up this important issue and considering the health and safety of our residents and climate.

Sincerely,
Maia Piccagli

Maia Piccagli
maiapic@gmail.com
1577 Treat Ave
San Francisco, California 94110

From: [Adrienne Gembala](#)
To: [Major, Erica \(BOS\)](#); [Board of Supervisors, \(BOS\)](#); [Preston, Dean \(BOS\)](#); [Peskin, Aaron \(BOS\)](#); [Safai, Ahsha \(BOS\)](#)
Subject: Public Comment Re: BoS File 200701
Date: Wednesday, September 16, 2020 9:01:50 PM

This message is from outside the City email system. Do not open links or attachments from untrusted sources.

Land Use Committee, Board of Supervisors, and Sup. Preston,

I'm a resident of San Francisco writing to strongly support prohibiting gas in new construction. The methane leaks, air pollution, and explosion dangers of natural gas are no longer necessary for the functioning of our homes and businesses. San Francisco can lead the state and the country in building a better future.

In addition to recommending the ordinance, I would also like to ask the Commission to recommend the changes to the ordinance as laid out by Earthjustice, the Sierra Club, the San Francisco Climate Emergency Coalition, and other local groups in their letter to the Commission and Board.

It is important to me that we:

1. Eliminate the feasibility exception to the electric-ready requirement and make fully electric-ready construction a baseline requirement for new construction. We know that the future is electric. Allowing any building to be built that will require massive retrofits in the near future is unacceptable. With full electric readiness, we minimize that retrofit cost.
2. Create a Clean Energy Building Hub through the City and County of San Francisco that provides for the outreach, resources, and education needed to eliminate barriers and maximize opportunity for all-electric new construction to benefit both climate and equity.
3. Expand the ordinance's definition of "mixed-fuel buildings" to include laboratory, industrial, and decorative uses of gas. Gas shouldn't be allowed for upscale decorative uses. It's wrong to harm public health for private enjoyment.
4. Provide additional limitations and transparency in the exemption process to ensure any project found exempt for infeasibility is truly in the public interest. I'm concerned about the news of powerful and connected people being able to get favors from DBI. We need sunshine on the exemption process, and exemptions should only be given in the public interest.
5. Amend section 106A.1.17 to require that the Building Official find "sufficient evidence was submitted to substantiate the infeasibility of an All-Electric Building or Project design without regard to financial, floor-area, or amenity-related loss unless deemed to be in the public welfare. The housing crisis is real. And we need to find ways of fixing it without sacrificing our children's future. The space taken up by a transformer should not be an acceptable reason for an exemption.

6. Eliminate the blanket exemption for commercial kitchens delaying compliance until 2022. Existing restaurants are not helped by giving builders a pass on making future commercial kitchens all-electric.

Thank you for taking up this important issue and considering the health and safety of our residents and climate.

Adrienne Gembala
adriennegembala@gmail.com
1617 Fulton Street
San Francisco, California 94117

From: [Jacob Hurwitz](#)
To: [Major, Erica \(BOS\)](#); [Board of Supervisors, \(BOS\)](#); [Preston, Dean \(BOS\)](#); [Peskin, Aaron \(BOS\)](#); [Safai, Ahsha \(BOS\)](#); [MandelmanStaff, \(BOS\)](#); [Ronen, Hillary](#)
Subject: Public Comment Re: BoS File 200701
Date: Wednesday, September 16, 2020 10:53:22 PM

This message is from outside the City email system. Do not open links or attachments from untrusted sources.

Land Use Committee, Board of Supervisors, and Sup. Ronen,

I'm a resident of San Francisco (D9) writing to strongly support prohibiting gas in new construction. The methane leaks, air pollution, and explosion dangers of natural gas are no longer necessary for the functioning of our homes and businesses. San Francisco can lead the state and the country in building a better future.

In addition to recommending the ordinance, I would also like to ask the Commission to recommend the changes to the ordinance as laid out by Earthjustice, the Sierra Club, the San Francisco Climate Emergency Coalition, and other local groups in their letter to the Commission and Board.

It is important to me that we:

1. Eliminate the feasibility exception to the electric-ready requirement and make fully electric-ready construction a baseline requirement for new construction. We know that the future is electric. Allowing any building to be built that will require massive retrofits in the near future is unacceptable. With full electric readiness, we minimize that retrofit cost.
2. Create a Clean Energy Building Hub through the City and County of San Francisco that provides for the outreach, resources, and education needed to eliminate barriers and maximize opportunity for all-electric new construction to benefit both climate and equity.
3. Expand the ordinance's definition of "mixed-fuel buildings" to include laboratory, industrial, and decorative uses of gas. Gas shouldn't be allowed for upscale decorative uses. It's wrong to harm public health for private enjoyment.
4. Provide additional limitations and transparency in the exemption process to ensure any project found exempt for infeasibility is truly in the public interest. I'm concerned about the news of powerful and connected people being able to get favors from DBI. We need sunshine on the exemption process, and exemptions should only be given in the public interest.
5. Amend section 106A.1.17 to require that the Building Official find "sufficient evidence was submitted to substantiate the infeasibility of an All-Electric Building or Project design without regard to financial, floor-area, or amenity-related loss unless deemed to be in the public welfare." The housing crisis is real. And we need to find ways of fixing it without sacrificing our children's future. The space taken up by a transformer should not be an acceptable reason for

an exemption.

6. Eliminate the blanket exemption for commercial kitchens delaying compliance until 2022. Existing restaurants are not helped by giving builders a pass on making future commercial kitchens all-electric.

Thank you for taking up this important issue and considering the health and safety of our residents and climate.

Jacob Hurwitz
jacobhurwitz@gmail.com
3228 22nd St
San Francisco, California 94110

From: [Joyce Calagos](#)
To: [Major, Erica \(BOS\)](#); [Board of Supervisors, \(BOS\)](#); [Preston, Dean \(BOS\)](#); [Peskin, Aaron \(BOS\)](#); [Safai, Ahsha \(BOS\)](#); [MandelmanStaff, \[BOS\]](#)
Subject: Public Comment Re: BoS File 200701
Date: Thursday, September 17, 2020 7:22:40 AM

This message is from outside the City email system. Do not open links or attachments from untrusted sources.

Land Use Committee, Board of Supervisors, and Sup. Safai,

I'm a resident of San Francisco since 1948! I live in District 11 where my supervisor is Ahsha Safai.

As the very first non-canonically professed Lay Promoter for Justice, Peace and Care of Creation of the Western Dominican Province of the Most Holy Name of Jesus, and as a member of Senior Disability Action, I am writing to urge you to strongly support the ordinance that would ban gas and use only earth-friendly, energy-saving electricity in construction.

Let San Francisco lead our State, our country, and the entire world in caring for creation by adopting this ordinance.

The methane leaks, air pollution, and explosion dangers of natural gas are no longer necessary for the functioning of our homes and businesses.

In addition to recommending the ordinance, I would also like to ask the Commission to recommend the changes to the ordinance as laid out by EarthJustice, the Sierra Club, the San Francisco Climate Emergency Coalition, and other local groups in their letter to the Commission and Board.

It is important to me that we:

1. Eliminate the feasibility exception to the electric-ready requirement and make fully electric-ready construction a baseline requirement for new construction. We know that the future is electric. Allowing any building to be built that will require massive retrofits in the near future is unacceptable. With full electric readiness, we minimize that retrofit cost.
2. Create a Clean Energy Building Hub through the City and County of San Francisco that provides for the outreach, resources, and education needed to eliminate barriers and maximize opportunity for all-electric new construction to benefit both climate and equity.
3. Expand the ordinance's definition of "mixed-fuel buildings" to include laboratory, industrial, and decorative uses of gas. Gas shouldn't be allowed for upscale decorative uses. It's wrong to harm public health for private enjoyment.
4. Provide additional limitations and transparency in the exemption process to ensure any project found exempt for infeasibility is truly in the public interest. I'm concerned about the

news of powerful and connected people being able to get favors from DBI. We need sunshine on the exemption process, and exemptions should only be given in the public interest.

5. Amend section 106A.1.17 to require that the Building Official find "sufficient evidence was submitted to substantiate the infeasibility of an All-Electric Building or Project design without regard to financial, floor-area, or amenity-related loss unless deemed to be in the public welfare." The housing crisis is real. And we need to find ways of fixing it without sacrificing our children's future. The space taken up by a transformer should not be an acceptable reason for an exemption.

6. Eliminate the blanket exemption for commercial kitchens delaying compliance until 2022. Existing restaurants are not helped by giving builders a pass on making future commercial kitchens all-electric.

Thank you for taking up this important issue and considering the health and safety of our residents and climate.

Joyce Calagos
joycecalagos1@gmail.com
1636 Geneva Ave.
San Francisco, California 94134

From: [Cherie Salonga](#)
To: [Major, Erica \(BOS\)](#); [Board of Supervisors, \(BOS\)](#); [Preston, Dean \(BOS\)](#); [Peskin, Aaron \(BOS\)](#); [Safai, Ahsha \(BOS\)](#); [MandelmanStaff, \(BOS\)](#); [Mar, Gordon \(BOS\)](#)
Subject: Public Comment Re: BoS File 200701
Date: Thursday, September 17, 2020 10:15:57 AM

This message is from outside the City email system. Do not open links or attachments from untrusted sources.

Land Use Committee, Board of Supervisors, and Sup. Mar,

I'm a resident of San Francisco writing to strongly support prohibiting gas in new construction. The methane leaks, air pollution, and explosion dangers of natural gas are no longer necessary for the functioning of our homes and businesses. San Francisco can lead the state and the country in building a better future.

In addition to recommending the ordinance, I would also like to ask the Commission to recommend the changes to the ordinance as laid out by Earthjustice, the Sierra Club, the San Francisco Climate Emergency Coalition, and other local groups in their letter to the Commission and Board.

It is important to me that we:

1. Eliminate the feasibility exception to the electric-ready requirement and make fully electric-ready construction a baseline requirement for new construction. We know that the future is electric. Allowing any building to be built that will require massive retrofits in the near future is unacceptable. With full electric readiness, we minimize that retrofit cost.
2. Create a Clean Energy Building Hub through the City and County of San Francisco that provides for the outreach, resources, and education needed to eliminate barriers and maximize opportunity for all-electric new construction to benefit both climate and equity.
3. Expand the ordinance's definition of "mixed-fuel buildings" to include laboratory, industrial, and decorative uses of gas. Gas shouldn't be allowed for upscale decorative uses. It's wrong to harm public health for private enjoyment.
4. Provide additional limitations and transparency in the exemption process to ensure any project found exempt for infeasibility is truly in the public interest. I'm concerned about the news of powerful and connected people being able to get favors from DBI. We need sunshine on the exemption process, and exemptions should only be given in the public interest.
5. Amend section 106A.1.17 to require that the Building Official find "sufficient evidence was submitted to substantiate the infeasibility of an All-Electric Building or Project design without regard to financial, floor-area, or amenity-related loss unless deemed to be in the public welfare." The housing crisis is real. And we need to find ways of fixing it without sacrificing our children's future. The space taken up by a transformer should not be an acceptable reason for

an exemption.

6. Eliminate the blanket exemption for commercial kitchens delaying compliance until 2022. Existing restaurants are not helped by giving builders a pass on making future commercial kitchens all-electric.

Thank you for taking up this important issue and considering the health and safety of our residents and climate.

Cherie Salonga
cherie.salonga@gmail.com
1401 43rd Avenue
San Francisco, California 94122

From: [Brittany Schiro](#)
To: [Major, Erica \(BOS\)](#)
Cc: [Board of Supervisors \(BOS\)](#); [Preston, Dean \(BOS\)](#); [Peskin, Aaron \(BOS\)](#); [Safai, Ahsha \(BOS\)](#)
Subject: Public Comment Re: BoS File 200701
Date: Thursday, September 17, 2020 10:30:28 AM

This message is from outside the City email system. Do not open links or attachments from untrusted sources.

To whom it may concern,

I'm a resident of San Francisco writing to strongly support prohibiting gas in new construction. The methane leaks, air pollution, and explosion dangers of natural gas are no longer necessary for the functioning of our homes and businesses. San Francisco can lead the state and the country in building a better future.

In addition to recommending the ordinance, I would also like to ask the Commission to recommend the changes to the ordinance as laid out by Earthjustice, the Sierra Club, the San Francisco Climate Emergency Coalition, and other local groups in their letter to the Commission and Board.

It is important to me that we:

1. Eliminate the feasibility exception to the electric-ready requirement and make fully electric-ready construction a baseline requirement for new construction. We know that the future is electric. Allowing any building to be built that will require massive retrofits in the near future is unacceptable. With full electric readiness, we minimize that retrofit cost.
2. Create a Clean Energy Building Hub through the City and County of San Francisco that provides for the outreach, resources, and education needed to eliminate barriers and maximize opportunity for all-electric new construction to benefit both climate and equity.
3. Expand the ordinance's definition of "mixed-fuel buildings" to include laboratory, industrial, and decorative uses of gas. Gas shouldn't be allowed for upscale decorative uses. It's wrong to harm public health for private enjoyment.
4. Provide additional limitations and transparency in the exemption process to ensure any project found exempt for infeasibility is truly in the public interest. I'm concerned about the news of powerful and connected people being able to get favors from DBI. We need sunshine on the exemption process, and exemptions should only be given in the public interest.
5. Amend section 106A.1.17 to require that the Building Official find "sufficient evidence was submitted to substantiate the infeasibility of an All-Electric Building or

Project design without regard to financial, floor-area, or amenity-related loss unless deemed to be in the public welfare." The housing crisis is real. And we need to find ways of fixing it without sacrificing our children's future. The space taken up by a transformer should not be an acceptable reason for an exemption.

6. Eliminate the blanket exemption for commercial kitchens delaying compliance until 2022. Existing restaurants are not helped by giving builders a pass on making future commercial kitchens all-electric.

Thank you for taking up this important issue and considering the health and safety of our residents and climate.

Sincerely,

Brittany Schiro

San Francisco Resident

From: [Daniel Tahara](#)
To: [Major, Erica \(BOS\)](#); [Board of Supervisors, \(BOS\)](#); [Preston, Dean \(BOS\)](#); [Peskin, Aaron \(BOS\)](#); [Safai, Ahsha \(BOS\)](#); [MandelmanStaff, \(BOS\)](#)
Subject: Public Comment Re: BoS File 200701
Date: Thursday, September 17, 2020 10:36:40 AM

This message is from outside the City email system. Do not open links or attachments from untrusted sources.

Land Use Committee, Board of Supervisors, and Sup. Mandelman,

I'm a resident of San Francisco writing to strongly support prohibiting gas in new construction. The methane leaks, air pollution, and explosion dangers of natural gas are no longer necessary for the functioning of our homes and businesses. San Francisco can lead the state and the country in building a better future.

In addition to recommending the ordinance, I would also like to ask the Commission to recommend the changes to the ordinance as laid out by Earthjustice, the Sierra Club, the San Francisco Climate Emergency Coalition, and other local groups in their letter to the Commission and Board.

It is important to me that we:

1. Eliminate the feasibility exception to the electric-ready requirement and make fully electric-ready construction a baseline requirement for new construction. We know that the future is electric. Allowing any building to be built that will require massive retrofits in the near future is unacceptable. With full electric readiness, we minimize that retrofit cost.
2. Create a Clean Energy Building Hub through the City and County of San Francisco that provides for the outreach, resources, and education needed to eliminate barriers and maximize opportunity for all-electric new construction to benefit both climate and equity.
3. Expand the ordinance's definition of "mixed-fuel buildings" to include laboratory, industrial, and decorative uses of gas. Gas shouldn't be allowed for upscale decorative uses. It's wrong to harm public health for private enjoyment.
4. Provide additional limitations and transparency in the exemption process to ensure any project found exempt for infeasibility is truly in the public interest. I'm concerned about the news of powerful and connected people being able to get favors from DBI. We need sunshine on the exemption process, and exemptions should only be given in the public interest.
5. Amend section 106A.1.17 to require that the Building Official find "sufficient evidence was submitted to substantiate the infeasibility of an All-Electric Building or Project design without regard to financial, floor-area, or amenity-related loss unless deemed to be in the public welfare." The housing crisis is real. And we need to find ways of fixing it without sacrificing our children's future. The space taken up by a transformer should not be an acceptable reason for

an exemption.

6. Eliminate the blanket exemption for commercial kitchens delaying compliance until 2022. Existing restaurants are not helped by giving builders a pass on making future commercial kitchens all-electric.

Thank you for taking up this important issue and considering the health and safety of our residents and climate.

Daniel Tahara
dktahara@gmail.com
466 14th St
San Francisco, California 94103

From: [Barbara Jue](#)
To: [Major, Erica \(BOS\)](#); [Board of Supervisors, \(BOS\)](#); [Preston, Dean \(BOS\)](#); [Peskin, Aaron \(BOS\)](#); [Safai, Ahsha \(BOS\)](#); [MandelmanStaff, \(BOS\)](#); [Haney, Matt \(BOS\)](#)
Subject: Public Comment Re: BoS File 200701
Date: Thursday, September 17, 2020 10:52:00 AM

This message is from outside the City email system. Do not open links or attachments from untrusted sources.

Land Use Committee, Board of Supervisors, and Sup. Haney,

I'm a resident of San Francisco writing to strongly support prohibiting gas in new construction. The methane leaks, air pollution, and explosion dangers of natural gas are no longer necessary for the functioning of our homes and businesses. Indeed these dangers are exacerbated in an area susceptible to earthquakes.

My particular neighborhood, The East Cut, is filled with recently constructed high-density housing much of which has been equipped with gas kitchens. There has been so much new gas infrastructure to support this development, and the resulting emissions along with the threats listed above put my neighborhood at risk. It certainly doesn't make me feel safe.

Therefore it is important to me that we make the following changes to the ordinance:

1. Eliminate the feasibility exception to the electric-ready requirement and make fully electric-ready construction a baseline requirement for new construction. We know that the future is electric. Allowing any building to be built that will require massive retrofits in the near future is unacceptable. With full electric readiness, we minimize that retrofit cost.
2. Create a Clean Energy Building Hub through the City and County of San Francisco that provides for the outreach, resources, and education needed to eliminate barriers and maximize opportunity for all-electric new construction to benefit both climate and equity.
3. Provide additional limitations and transparency in the exemption process to ensure any project found exempt for infeasibility is truly in the public interest. I'm concerned about the news of powerful and connected people being able to get favors from DBI. We need sunshine on the exemption process, and exemptions should only be given in the public interest.
4. Eliminate the blanket exemption for commercial kitchens delaying compliance until 2022. There is no reason why new kitchens cannot be all-electric going forward.

Thank you for taking up this important issue and considering the health and safety of our residents and climate.

Barbara Jue
sfbar48@gmail.com
81 Lansing Street, #411

San Francisco, California 94105

From: [Charles Whitfield](#)
To: [Major, Erica \(BOS\)](#); [Board of Supervisors, \(BOS\)](#); [Preston, Dean \(BOS\)](#); [Peskin, Aaron \(BOS\)](#); [Safai, Ahsha \(BOS\)](#); [MandelmanStaff, \[BOS\]](#)
Subject: Public Comment Re: BoS File 200701 (Item 1 of 9/21 Land Use)
Date: Thursday, September 17, 2020 11:37:36 AM

This message is from outside the City email system. Do not open links or attachments from untrusted sources.

Land Use Committee, Board of Supervisors, and Sup. Mandelman,

I'm a resident of San Francisco writing to strongly support prohibiting gas in new construction. The methane leaks, air pollution, and explosion dangers of natural gas are no longer necessary for the functioning of our homes and businesses. San Francisco can lead the state and the country in building a better future.

In addition to recommending the ordinance, I would also like to ask the Commission to recommend the changes to the ordinance as laid out by Earthjustice, the Sierra Club, the San Francisco Climate Emergency Coalition, and other local groups in their letter to the Commission and Board.

It is important to me that we:

1. Eliminate the feasibility exception to the electric-ready requirement and make fully electric-ready construction a baseline requirement for new construction. We know that the future is electric. Allowing any building to be built that will require massive retrofits in the near future is unacceptable. With full electric readiness, we minimize that retrofit cost.
2. Create a Clean Energy Building Hub through the City and County of San Francisco that provides for the outreach, resources, and education needed to eliminate barriers and maximize opportunity for all-electric new construction to benefit both climate and equity.
3. Expand the ordinance's definition of "mixed-fuel buildings" to include laboratory, industrial, and decorative uses of gas. Gas shouldn't be allowed for upscale decorative uses. It's wrong to harm public health for private enjoyment.
4. Provide additional limitations and transparency in the exemption process to ensure any project found exempt for infeasibility is truly in the public interest. I'm concerned about the news of powerful and connected people being able to get favors from DBI. We need sunshine on the exemption process, and exemptions should only be given in the public interest.
5. Amend section 106A.1.17 to require that the Building Official find "sufficient evidence was submitted to substantiate the infeasibility of an All-Electric Building or Project design without regard to financial, floor-area, or amenity-related loss unless deemed to be in the public welfare." The housing crisis is real. And we need to find ways of fixing it without sacrificing our children's future. The space taken up by a transformer should not be an acceptable reason for

an exemption.

6. Eliminate the blanket exemption for commercial kitchens delaying compliance until 2022. Existing restaurants are not helped by giving builders a pass on making future commercial kitchens all-electric.

Thank you for taking up this important issue and considering the health and safety of our residents and climate.

Charles Whitfield
whitfield.cw@gmail.com
233 Eureka Street
San Francisco, California 94114

From: [NIDHI KALRA](#)
To: [Major, Erica \(BOS\)](#); [Board of Supervisors, \(BOS\)](#); [Preston, Dean \(BOS\)](#); [Peskin, Aaron \(BOS\)](#); [Safai, Ahsha \(BOS\)](#); [MandelmanStaff, \[BOS\]](#)
Subject: Public Comment Re: BoS File 200701 (Item 1 of 9/21 Land Use)
Date: Thursday, September 17, 2020 12:01:10 PM

This message is from outside the City email system. Do not open links or attachments from untrusted sources.

Land Use Committee, Board of Supervisors, and Sup. Mandelman,

I'm a resident of San Francisco writing to strongly support prohibiting gas in new construction. The methane leaks, air pollution, and explosion dangers of natural gas are no longer necessary for the functioning of our homes and businesses. San Francisco can lead the state and the country in building a better future.

In addition to recommending the ordinance, I would also like to ask the Commission to recommend the changes to the ordinance as laid out by Earthjustice, the Sierra Club, the San Francisco Climate Emergency Coalition, and other local groups in their letter to the Commission and Board.

It is important to me that we:

1. Eliminate the feasibility exception to the electric-ready requirement and make fully electric-ready construction a baseline requirement for new construction. We know that the future is electric. Allowing any building to be built that will require massive retrofits in the near future is unacceptable. With full electric readiness, we minimize that retrofit cost.
2. Create a Clean Energy Building Hub through the City and County of San Francisco that provides for the outreach, resources, and education needed to eliminate barriers and maximize opportunity for all-electric new construction to benefit both climate and equity.
3. Expand the ordinance's definition of "mixed-fuel buildings" to include laboratory, industrial, and decorative uses of gas. Gas shouldn't be allowed for upscale decorative uses. It's wrong to harm public health for private enjoyment.
4. Provide additional limitations and transparency in the exemption process to ensure any project found exempt for infeasibility is truly in the public interest. I'm concerned about the news of powerful and connected people being able to get favors from DBI. We need sunshine on the exemption process, and exemptions should only be given in the public interest.
5. Amend section 106A.1.17 to require that the Building Official find "sufficient evidence was submitted to substantiate the infeasibility of an All-Electric Building or Project design without regard to financial, floor-area, or amenity-related loss unless deemed to be in the public welfare." The housing crisis is real. And we need to find ways of fixing it without sacrificing our children's future. The space taken up by a transformer should not be an acceptable reason for

an exemption.

6. Eliminate the blanket exemption for commercial kitchens delaying compliance until 2022. Existing restaurants are not helped by giving builders a pass on making future commercial kitchens all-electric.

Thank you for taking up this important issue and considering the health and safety of our residents and climate.

NIDHI KALRA

nidhi.r.kalra@gmail.com

4039 26th St.

San Francisco, California 94131

From: [Danielle Maybach](#)
To: [Major, Erica \(BOS\)](#); [Board of Supervisors, \(BOS\)](#); [Preston, Dean \(BOS\)](#); [Peskin, Aaron \(BOS\)](#); [Safai, Ahsha \(BOS\)](#); [MandelmanStaff, \(BOS\)](#); [Stefani, Catherine \(BOS\)](#)
Subject: Public Comment Re: BoS File 200701 (Item 1 of 9/21 Land Use)
Date: Thursday, September 17, 2020 12:23:17 PM

This message is from outside the City email system. Do not open links or attachments from untrusted sources.

Land Use Committee, Board of Supervisors, and Sup. Stefani,

I'm a resident of San Francisco writing to strongly support prohibiting gas in new construction. The methane leaks, air pollution, and explosion dangers of natural gas are no longer necessary for the functioning of our homes and businesses. San Francisco can lead the state and the country in building a better future.

In addition to recommending the ordinance, I would also like to ask the Commission to recommend the changes to the ordinance as laid out by Earthjustice, the Sierra Club, the San Francisco Climate Emergency Coalition, and other local groups in their letter to the Commission and Board.

It is important to me that we:

1. Eliminate the feasibility exception to the electric-ready requirement and make fully electric-ready construction a baseline requirement for new construction. We know that the future is electric. Allowing any building to be built that will require massive retrofits in the near future is unacceptable. With full electric readiness, we minimize that retrofit cost.
2. Create a Clean Energy Building Hub through the City and County of San Francisco that provides for the outreach, resources, and education needed to eliminate barriers and maximize opportunity for all-electric new construction to benefit both climate and equity.
3. Expand the ordinance's definition of "mixed-fuel buildings" to include laboratory, industrial, and decorative uses of gas. Gas shouldn't be allowed for upscale decorative uses. It's wrong to harm public health for private enjoyment.
4. Provide additional limitations and transparency in the exemption process to ensure any project found exempt for infeasibility is truly in the public interest. I'm concerned about the news of powerful and connected people being able to get favors from DBI. We need sunshine on the exemption process, and exemptions should only be given in the public interest.
5. Amend section 106A.1.17 to require that the Building Official find "sufficient evidence was submitted to substantiate the infeasibility of an All-Electric Building or Project design without regard to financial, floor-area, or amenity-related loss unless deemed to be in the public welfare." The housing crisis is real. And we need to find ways of fixing it without sacrificing our children's future. The space taken up by a transformer should not be an acceptable reason for

an exemption.

6. Eliminate the blanket exemption for commercial kitchens delaying compliance until 2022. Existing restaurants are not helped by giving builders a pass on making future commercial kitchens all-electric.

Thank you for taking up this important issue and considering the health and safety of our residents and climate.

Danielle Maybach
danielle.maybach@gmail.com
3106 Fillmore Street, Second Floor
San Francisco, California 94123

From: [C. Homsey](#)
To: [Major, Erica \(BOS\)](#)
Cc: [Peskin, Aaron \(BOS\)](#); [Safai, Ahsha \(BOS\)](#); [Board of Supervisors, \(BOS\)](#); [Preston, Dean \(BOS\)](#); [Yee, Norman \(BOS\)](#)
Subject: Public Comment Re: BoS File 200701
Date: Thursday, September 17, 2020 1:12:37 PM

This message is from outside the City email system. Do not open links or attachments from untrusted sources.

Dear Ms. Major,

I'm a resident of San Francisco writing to strongly support prohibiting gas in new construction. The methane leaks, air pollution, and explosion dangers of natural gas are no longer necessary for the functioning of our homes and businesses. San Francisco can lead the state and the country in building a better future.

In addition to recommending the ordinance, I would also like to ask the Commission to recommend the changes to the ordinance as laid out by Earthjustice, the Sierra Club, the San Francisco Climate Emergency Coalition, and other local groups in their letter to the Commission and Board.

It is important to me that we:

1. Eliminate the feasibility exception to the electric-ready requirement and make fully electric-ready construction a baseline requirement for new construction. We know that the future is electric. Allowing any building to be built that will require massive retrofits in the near future is unacceptable. With full electric readiness, we minimize that retrofit cost.
2. Create a Clean Energy Building Hub through the City and County of San Francisco that provides for the outreach, resources, and education needed to eliminate barriers and maximize opportunity for all-electric new construction to benefit both climate and equity.
3. Expand the ordinance's definition of "mixed-fuel buildings" to include laboratory, industrial, and decorative uses of gas. Gas shouldn't be allowed for upscale decorative uses. It's wrong to harm public health for private enjoyment.
4. Provide additional limitations and transparency in the exemption process to ensure any project found exempt for infeasibility is truly in the public interest. I'm concerned about the news of powerful and connected people being able to get favors from DBI. We need sunshine on the exemption process, and exemptions should only be given in the public interest.
5. Amend section 106A.1.17 to require that the Building Official find "sufficient evidence was submitted to substantiate the infeasibility of an All-Electric Building or Project design without regard to financial, floor-area, or amenity-related loss unless

deemed to be in the public welfare." The housing crisis is real. And we need to find ways of fixing it without sacrificing our children's future. The space taken up by a transformer should not be an acceptable reason for an exemption.

6. Eliminate the blanket exemption for commercial kitchens delaying compliance until 2022. Existing restaurants are not helped by giving builders a pass on making future commercial kitchens all-electric.

Thank you for taking up this important issue and considering the health and safety of our residents and climate.

Sincerely,

Catherine Homsey
140 Bella Vista Way
San Francisco, CA 94127

--

Catherine Homsey
415.608.3181
joyofzerowaste.com
Instagram & Facebook @joyofzerowaste

From: [Rebecca Barker](#)
To: [Tanenberg, Diedre \(ENV\)](#)
Cc: mvespa@earthjustice.org; [Sheehan, Charles \(ENV\)](#); [Peskin, Aaron \(BOS\)](#); [Angulo, Sunny \(BOS\)](#); [Hepner, Lee \(BOS\)](#); [Safai, Ahsha \(BOS\)](#); [Sandoval, Suhagey \(BOS\)](#); [Preston, Dean \(BOS\)](#); [Snyder, Jen \(BOS\)](#); [Smeallie, Kyle \(BOS\)](#); [Mandelman, Rafael \(BOS\)](#); [Bintliff, Jacob \(BOS\)](#); [MandelmanStaff, \[BOS\]](#); [Raphael, Deborah \(ENV\)](#); patrick.o.riordan@sfgov.org; [Board of Supervisors, \(BOS\)](#); [Major, Erica \(BOS\)](#); [Harris, Sonya \(DBI\)](#); dktahara@gmail.com; c@n-a-s-o.com; matt.gough@sierraclub.org
Subject: Comment Letter for July 28 Commission on the Environment Meeting
Date: Monday, July 27, 2020 4:50:45 PM
Attachments: [ATT00001.png](#)
[BE Ordinance Letter of Support from Earthjustice, SC, SFCEC, and Allies.pdf](#)

This message is from outside the City email system. Do not open links or attachments from untrusted sources.

Hello,

Attached please find a letter from Earthjustice, Sierra Club, SF Climate Emergency Coalition, and many more allied organizations in support of the building electrification ordinance (Board of Supervisors File No. 200701) listed as agenda item #7 for the Commission on the Environment's July 28 meeting. Please don't hesitate to reach out with any questions or concerns.

Thank you,
Rebecca Barker

Rebecca Barker
She/her/hers
Associate Attorney
Clean Energy Program
50 California Street, Suite 500
San Francisco, CA 94111
Phone: 415.217.2056
rbarker@earthjustice.org



The information contained in this email message may be privileged, confidential and protected from disclosure. If you are not the intended recipient, any dissemination, distribution or copying is strictly prohibited. If you think that you have received this email message in error, please notify the sender by reply email and delete the message and any attachments.

Introduction Form

By a Member of the Board of Supervisors or Mayor

Time stamp
or meeting date

I hereby submit the following item for introduction (select only one):

- 1. For reference to Committee. (An Ordinance, Resolution, Motion or Charter Amendment).
- 2. Request for next printed agenda Without Reference to Committee.
- 3. Request for hearing on a subject matter at Committee.
- 4. Request for letter beginning : "Supervisor [] inquiries"
- 5. City Attorney Request.
- 6. Call File No. [] from Committee.
- 7. Budget Analyst request (attached written motion).
- 8. Substitute Legislation File No. []
- 9. Reactivate File No. []
- 10. Topic submitted for Mayoral Appearance before the BOS on []

Please check the appropriate boxes. The proposed legislation should be forwarded to the following:

- Small Business Commission
- Youth Commission
- Ethics Commission
- Planning Commission
- Building Inspection Commission

Note: For the Imperative Agenda (a resolution not on the printed agenda), use the Imperative Form.

Sponsor(s):

Mandelman

Subject:

[Building Code - Mandating New Construction Be All-Electric]

The text is listed:

Ordinance amending the Building Code to require new construction to utilize only electric power; adopting findings of local conditions under the California Health and Safety Code; affirming the Planning Department's determination under the California Environmental Quality Act; and directing the Clerk of the Board of Supervisors to forward this ordinance to the California Building Standards Commission upon final passage.

Signature of Sponsoring Supervisor: []

For Clerk's Use Only