

File No. 100833

Committee Item No. 1

Board Item No. _____

COMMITTEE/BOARD OF SUPERVISORS

AGENDA PACKET CONTENTS LIST

Committee: Land Use and Economic Development Date July 26, 2010

Board of Supervisors Meeting

Date _____

Cmte Board

- | | | |
|-------------------------------------|--------------------------|--|
| <input type="checkbox"/> | <input type="checkbox"/> | Motion |
| <input checked="" type="checkbox"/> | <input type="checkbox"/> | Resolution |
| <input type="checkbox"/> | <input type="checkbox"/> | Ordinance |
| <input type="checkbox"/> | <input type="checkbox"/> | Legislative Digest |
| <input type="checkbox"/> | <input type="checkbox"/> | Budget Analyst Report |
| <input type="checkbox"/> | <input type="checkbox"/> | Legislative Analyst Report |
| <input type="checkbox"/> | <input type="checkbox"/> | Youth Commission Report |
| <input type="checkbox"/> | <input type="checkbox"/> | Introduction Form (for hearings) |
| <input type="checkbox"/> | <input type="checkbox"/> | Department/Agency Cover Letter and/or Report |
| <input type="checkbox"/> | <input type="checkbox"/> | MOU |
| <input type="checkbox"/> | <input type="checkbox"/> | Grant Information Form |
| <input type="checkbox"/> | <input type="checkbox"/> | Grant Budget |
| <input type="checkbox"/> | <input type="checkbox"/> | Subcontract Budget |
| <input type="checkbox"/> | <input type="checkbox"/> | Contract/Agreement |
| <input type="checkbox"/> | <input type="checkbox"/> | Form 126 – Ethics Commission |
| <input type="checkbox"/> | <input type="checkbox"/> | Award Letter |
| <input type="checkbox"/> | <input type="checkbox"/> | Application |
| <input type="checkbox"/> | <input type="checkbox"/> | Public Correspondence |

OTHER

(Use back side if additional space is needed)

- | | | |
|-------------------------------------|--------------------------|---|
| <input checked="" type="checkbox"/> | <input type="checkbox"/> | <u>Major Encroachment Permit Request, Dated May 07, 2009</u> |
| <input checked="" type="checkbox"/> | <input type="checkbox"/> | <u>Planning Department General Plan Determination, Dated April 14, 2010</u> |
| <input checked="" type="checkbox"/> | <input type="checkbox"/> | <u>Street Encroachment Agreement</u> |
| <input checked="" type="checkbox"/> | <input type="checkbox"/> | <u>Project Plans</u> |
| <input type="checkbox"/> | <input type="checkbox"/> | _____ |
| <input type="checkbox"/> | <input type="checkbox"/> | _____ |
| <input type="checkbox"/> | <input type="checkbox"/> | _____ |
| <input type="checkbox"/> | <input type="checkbox"/> | _____ |

Completed by: LaTonia Stokes Date July 23, 2010

Completed by: _____ Date _____

An asterisked item represents the cover sheet to a document that exceeds 25 pages.
The complete document can be found in the file.

1 [Approving Street Encroachment at Lake Merced Boulevard and Higuera Avenue]

2
3 **Resolution granting revocable permission to Park Merced Investors Properties, LLC to**
4 **occupy a portion of the public right-of-way for the installation and maintenance of a**
5 **neighborhood sign (4' high x 36' wide x 32" deep) at the corner of Lake Merced**
6 **Boulevard and Higuera Avenue in the median island (Block 0807, Lot 012), conditioned**
7 **upon the payment of an annual assessment fee.**

8
9 WHEREAS, pursuant to Public Works Code Section 786, permission was requested by
10 Stellar Management, agent for the owner, Park Merced Investors Properties, LLC to occupy a
11 portion of the public right-of-way for the installation and maintenance of a neighborhood sign
12 at the corner of Lake Merced Boulevard and Higuera Avenue in the median, as shown on the
13 plans, a copy of which is on file in the office of the Clerk of the Board of Supervisors in File
14 No. 100833; and

15 WHEREAS, The Department of City Planning, by letter dated April 14, 2010, declared
16 that the proposed encroachment does conform with the General Plan and with the priority
17 policies of Planning Code Section 101.1. A copy of said letter is on file with the Clerk of the
18 Board of Supervisors in File No. 100833, and is incorporated herein by reference; and

19 WHEREAS, At a duly noticed public hearing on June 2, 2010, the Department of Public
20 Works recommended approval of the proposed encroachment; and

21 WHEREAS, Notwithstanding the determination set forth above, it is the decision of the
22 Board of Supervisors that the propose encroachments are in the best interest of the general
23 public, are desirable and convenient with the owner's use and enjoyment of its property, and
24 is appropriate use of the public right-of-way; and

1 WHEREAS, The permit and associated encroachment agreement, which are
2 incorporated herein by reference and attached hereto as Exhibit A, shall not become effective
3 until:

4 (a) The Permittee executes and acknowledges the permit and delivers said permit to
5 the City's Controller, and

6 (b) Permittee delivers to the City Controller a policy of insurance provided for in said
7 agreement and the Controller shall have had approved the same as complying with the
8 requirement of said agreement. The Controller may, in his discretion, accept, in lieu of said
9 insurance policy, the certificate of an insurance company certifying to the existence of such a
10 policy; and

11 (c) The City Controller records the permit and associated agreement in the office of the
12 County Recorder; and

13 WHEREAS, The Permittee, at the Permittee's sole expense and as is necessary as a
14 result of this permit, shall make the following arrangements:

15 (a) To provide for the support and protection of facilities belonging to the Department of
16 Public Works, San Francisco Water Department, the San Francisco Fire Department and
17 other City Departments, and public utility companies; and

18 (b) To remove or relocate such facilities and provide access to such facilities for the
19 purpose of constructing, reconstructing, maintaining, operating, or repairing such facilities;
20 and

21 WHEREAS, The Permittee shall procure the necessary permits from the Central Permit
22 Bureau, Department of Building Inspection and/or Bureau of Street-Use and Mapping,
23 Department of Public Works, and pay the necessary permit fees and inspection fees before
24 starting work; and
25

1 WHEREAS, The Board of Supervisors shall implement an annual assessment fee for
2 the use of said right-of-ways, which shall be increased at the beginning of each fiscal year
3 based upon the Consumer Price Index quotient, and shall be re-evaluated by DPW every five
4 (5) years; and

5 WHEREAS, No structure shall be erected or constructed within said street right-of-way
6 except as specifically permitted herein; and

7 WHEREAS, The Permittee shall assume all costs for the maintenance and repair of the
8 encroachments and no cost or obligation of any kind shall accrue to the City and County of
9 San Francisco by reason of this permission granted; now, therefore, be it

10 RESOLVED, That pursuant to Public Works Code Section 786, the Board of
11 Supervisors hereby grants permission, revocable at the will of the Director of the Department
12 of Public Works, to Park Merced Investors Properties, LLC, to occupy a portion of the public
13 right-of-way for the installation and maintenance of a neighborhood sign (4' high x 36' wide x
14 32" deep) at the corner of Lake Merced Boulevard and Higuera Avenue in the median island
15 (Block 7333C, Lot 001), conditioned upon the payment of an annual assessment fee; and, be
16 it

17 FURTHER RESOLVED, That this Board adopts the findings of the Planning
18 Department, which determined that said permit is consistent with the General Plan and the
19 priority policies of Planning Code Section 101.1.

RECEIVED
BUREAU OF STREET USE & MAPPING

JUL 20 2009

DEPT. OF PUBLIC WORKS

7 May 2009

City of San Francisco
Department of Public Works
875 Stevenson Street
San Francisco, CA 94103
Attn: Edward Reiskin

RE: Major Encroachment Permit Application

Dear Edward,

I am writing this letter to request a Major Encroachment Permit for the construction of a new monument sign at the corner of Lake Merced Boulevard and Higuera Avenue. Please find the enclosed 6 sets of drawings of the projects and a completed General Plan Referral Application.

Description of Project: Addition of an approximately 4' high by 36' wide by 32" deep monument sign, located at Lake Merced Blvd. street median at Higuera Avenue. The monument sign will be constructed of concrete masonry units with a stucco finish. Raised letters will be installed on both of the long vertical faces of the sign indicating "Park Merced." A cast stone cap will be installed on the top of the monument sign, in keeping with existing monument signs at Park Merced.

Client: Stellar Management, 3711 19th Avenue, San Francisco, CA 94132 (attn: Adam Mayer)

Client's Representative: Surfacedesign, Inc., 131 Lower Terrace, San Francisco, CA 94114 (attn: Geoff di Girolamo. 415 621 5522 x 3

Associated Work: Currently, the Client maintains a small planting bed in the center of the aforementioned median. The area around the proposed sign will be planted and irrigated. In December 2008, the client submitted a sidewalk planting application with the Bureau of Urban Forestry.

Thank you for your attention to this application. Please do not hesitate to call me if you have any questions about the project or if I can provide you with additional information.

Best regards,

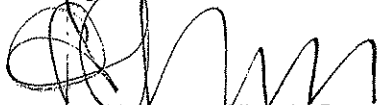

Geoff di Girolamo, Client's Representative
Cc: Adam Mayer, Stellar Management



SAN FRANCISCO PLANNING DEPARTMENT

April 14, 2010

Clinton Choy
City and County of San Francisco
Department of Public Works/BSM
875 Stevenson St, Room 460
San Francisco, CA 94103

RECEIVED
BUREAU OF STREET USE & MAPPING

APR 20 2010

DEPT. OF PUBLIC WORKS

1650 Mission St.
Suite 400
San Francisco,
CA 94103-2479

Reception:
415.558.6378

Fax:
415.558.6409

Planning
Information:
415.558.6377

RE: Case No. 2009.0867R; Higuera Avenue Monument

Dear Mr. Choy,

We are responding to your request for a General Plan Referral for the installation of a major encroachment in the public right-of-way fronting the property at the intersection of Lake Merced Boulevard and Higuera Avenue. The General Plan Referral is conducted pursuant to San Francisco Charter Section 4.105 and Section 2A.53 of the Administrative Code. We find the proposed project to be on balance **in conformity** with the General Plan.

Findings Summary

The project proposes the construction of a 4' high by 36" wide by 32" deep concrete and stucco monument sign in the median of the intersection of Lake Merced Boulevard and Higuera Avenue. The sign will be surrounded by landscaping and irrigation.

While the General Plan contains *policies* that stress the importance of retaining the public rights-of-way, on balance the proposed project is consistent with the General Plan. The key concern with the project pertains not so much to the project itself as to the cumulative impacts of similar projects should it set a precedent. This warrants further discussion, but the stance of staff is that this does not constitute sufficient grounds for a finding that the project is not in General Plan conformity.

Environmental Review

The project is a Class 3 Categorical exemption, New Construction of conversion of small structures and Class 1(c) (5) all work on sidewalks, curbs and gutters, including addition of sidewalk bulbs.

Planning Code Section 101.1 Priority Policies

The project has been reviewed for consistency with the Eight Priority Policies of the Planning Code Section 101.1 and the findings are attached.

Sincerely,

A handwritten signature in black ink, appearing to read "John Rahaim", with a long horizontal flourish extending to the right.

John Rahaim

Director of Planning

Attachments:

1. General Plan Case Report
2. Planning Code Sec. 101.1(b) Priority Policies

CC: A. Kiefer, Planner

General Plan Policy Findings

Note: General Plan Objectives and Policies are in **bold font**, General Plan text is in regular font, and staff comments are in *italic font*.

DESIGN ELEMENT OF GENERAL PLAN

Objective 2

Conservation of resources which provide a sense of nature, continuity with the past, and freedom from overcrowding.

Street Space

Policy 2.8

Maintain a strong presumption against the giving up of street areas for private ownership or use, or for construction of public buildings.

Like other public resources, streets are irreplaceable, and they should not be easily given up. Short-term gains in stimulating development, receipt of purchase money and additions to tax revenues will generally compare unfavorably with the long-term loss of public values. (...) A strong presumption should be maintained, therefore, against the giving up of street areas, a presumption that can be overcome only by extremely positive and far reaching justification.

While the policy talks about streets as "irreplaceable", the project is in effect establishing a positive addition to the neighborhood. However, the major encroachment of part of the street remains the only concern with the project from the perspective of Policy 2.8, but also Policy 2.10, which states that "[S]treet areas should be treated as precious assets which might be required for unanticipated public needs at some future time." (See more below.)

Policy 2.9

Review proposals for the giving up of street areas in terms of all the public values that streets afford.

Every proposal for the giving up of public rights in street areas, through vacation, sale or lease of air rights, revocable permit or other means, shall be judged with the following criteria as the minimum basis for review:

- a. No release of a street area shall be recommended which would result in:
 - (1) Detriment to vehicular or pedestrian circulation;
Project is not in conflict with this policy.
 - (2) Interference with the rights of access to any private property;
Project is not in conflict with this policy.
 - (3) Inhibiting of access for fire protection or any other emergency purpose, or interference with utility lines or service without adequate reimbursement;
Project is not in conflict with this policy.
 - (4) Obstruction or diminishing of a significant view, or elimination of a viewpoint;
industrial operations;
Project is not in conflict with this policy.

(5) Elimination or reduction of open space which might feasibly be used for public recreation;

Project is not in conflict with this policy.

(6) Elimination of street space adjacent to a public facility, such as a park, where retention of the street might be of advantage to the public facility;

Project is not in conflict with this policy.

(7) Elimination of street space that has formed the basis for creation of any lot, or construction or occupancy of any building according to standards that would be violated by discontinuance of the street;

Project is not in conflict with this policy.

(8) Enlargement of a property that would result in (i) additional dwelling units in a multi-family area; (ii) excessive density for workers in a commercial area; or (iii) a building of excessive height or bulk;

Project is not in conflict with this policy.

(9) Reduction of street space in areas of high building intensity, without provision of new open space in the same area of equivalent amount and quality and reasonably accessible for public enjoyment;

Project is not in conflict with this policy.

(10) Removal of significant natural features, or detriment to the scale and character of surrounding development.

Project is not in conflict with this policy.

(11) Adverse effect upon any element of the General Plan or upon an area plan or other plan of the Department of City Planning; or

Project is not in conflict with this policy.

(12) Release of a street area in any situation in which the future development or use of such street area and any property of which it would become a part is unknown.

Project is not in conflict with this policy.

a. Release of a street area may be considered favorably when it would not violate any of the above criteria and when it would be:

(1) Necessary for a subdivision, redevelopment project or other project involving assembly of a large site, in which a new and improved pattern would be substituted for the existing street pattern;

Not Applicable.

(2) In furtherance of an industrial project where the existing street pattern would not fulfill the requirements of modern industrial operations;

Not Applicable.

(3) Necessary for a significant public or semi-public use, or public assembly use, where the nature of the use and the character of the development proposed present strong justifications for occupying the street area rather than some other site;

The major encroachment of this portion of the street for this sign would support this policy because the character of the sign is neighborhood-serving.

(4) For the purpose of permitting a small-scale pedestrian crossing consistent with the principles and policies of The Urban Design Element; or

Not Applicable.

(5) In furtherance of the public values and purposes of streets as expressed in The Urban Design Element and elsewhere in the General Plan.

The "public values" is interpreted to be a preservation of the public realm where possible. The project enhances the public realm by adding neighborhood signage.

Policy 2.10

Permit release of street areas, where such release is warranted, only in the least extensive and least permanent manner appropriate to each case.

In order to avoid the unnecessary permanent loss of streets as public assets, methods of release short of total vacation should be considered in cases in which some form of release is warranted. Such lesser methods of release permit later return of the street space to street purposes, and allow imposition of binding conditions as to development and use of the street area.

(...)

[S]treet areas should be treated as precious assets which might be required for unanticipated public needs at some future time.

Streets are emphasized as public assets, and this release of the street area is warranted because it is limited and appropriate for the street signage.

Planning Code Section 101.1 Priority Policies Findings

The following Priority Policies are hereby established. They shall be included in the preamble to the General Plan and shall be the basis upon which inconsistencies in the General Plan are resolved:

1. That existing neighborhood-serving retail uses be preserved and enhanced and future opportunities for resident employment in and ownership of such businesses enhanced;
Project is not in conflict with this policy.
2. That existing housing and neighborhood character be conserved and protected in order to preserve the cultural and economic diversity of our neighborhoods;
Project is not in conflict with this policy.
3. That the City's supply of affordable housing be preserved and enhanced;
Project is not in conflict with this policy.
4. That commuter traffic not impede Muni transit services or overburden our streets or neighborhood parking;
Project is not in conflict with this policy.
5. That a diverse economic base be maintained by protecting our industrial and service sectors from displacement due to commercial office development, and that future opportunities for resident employment and ownership in these sectors be enhanced;
Project is not in conflict with this policy.
6. That the City achieve the greatest possible preparedness to protect against injury and the loss of life in an earthquake.
Project is not in conflict with this policy.
7. That landmarks and historic buildings be preserved; and
Project is not in conflict with this policy.
8. That our parks and open space and their access to sunlight and vistas be protected from development.
Project is not in conflict with this policy.



**CITY AND COUNTY OF SAN FRANCISCO
DEPARTMENT OF PUBLIC WORKS**

STREET ENCROACHMENT AGREEMENT

WITNESSETH

In consideration of the adoption by the Board of Supervisors of the City and County of San Francisco of Resolution No. _____ at its meeting of _____, a true copy of which is attached hereto marked Exhibit A, and by this reference incorporated herein, and subject to all the terms, conditions and restrictions of this Agreement, also by reference incorporated herein, Permittee agrees that in accordance with this agreement and Exhibit A:

1. The permitted encroachment shall constitute a revocable license, shall be personal to Permittee and shall not be assignable or transferable by Permittee, whether separate from or together with any interest of Permittee.

Upon revocation the undersigned permittee, subsequent owners, or their heirs and assignees will within 30 days remove or cause to be removed the encroachment and all materials used in connections with its construction, without expense to the City and County of San Francisco, and shall restore the area to a condition satisfactory to the Department of Public Works.

2. The occupancy, construction and maintenance of the encroachment shall be in the location and as specified by the plans submitted, revised, approved and filed in the Department of Public Works. The permittee, by acceptance of this permit, acknowledges its responsibility to comply with all requirements of the occupancy, construction and maintenance of the encroachment as specified in Public Works Code Section 786 and with the sidewalk maintenance requirements specified in Public Works Code Section 706.
3. The permittee shall verify the locations of City and public service utility company facilities that may be affected by the work authorized by this permit and shall assume all responsibility for any damage to such facilities due to the work. The permittee shall make satisfactory arrangements and payments for any necessary temporary relocation of City and public utility company facilities.
4. In consideration of this Permit being issued for the work described in the application, Permittee on its behalf and that of any successor or assign, and on behalf of any lessee, promises and agrees to perform all the terms of this Permit and to comply with all applicable laws, ordinances and regulations.

Permittee agrees on its behalf and that of any successor or assign to hold harmless, defend, and indemnify the City and County of San Francisco, including, without limitation, each of its commissions, departments, officers, agents and employees (hereinafter collectively referred to as the "City") from and against any and all losses, liabilities, expenses, claims, demands, injuries, damages, fines, penalties, costs or judgments including, without limitation, attorneys' fees and costs (collectively, "claims") of any kind allegedly arising directly or indirectly from (i) any act by, omission by, or negligence of, Permittee or its subcontractors, or the offices, agents or employees of either, while engaged in the performance of the work authorized by this Permit, or while in or about the property subject to this Permit for any reason connected in any way whatsoever with the performance of the work authorized by this Permit, or allegedly resulting directly or indirectly from the maintenance or installation of any equipment, facilities or structures authorized under this Permit, (ii) any accident or injury to any contractor or subcontractor, or any officer, agent, or employee of either of them, while engaged in the performance of the work authorized by this Permit, or while in or about the property, for any reason connected with the performance of the work authorized by this Permit, or arising from liens or claims for services rendered or labor or materials furnished in or for the performance of the work authorized by this Permit, (iii) injuries or damages to real or personal property, good will, and persons in, upon or in any way allegedly connected with the work authorized by this Permit from any cause or claims arising at any time, and potentially falls within this indemnity provision, even if the allegations are or may be groundless, false or fraudulent, which obligations arises at the time such claim is tendered to Permittee by the City and continues at all times thereafter. Permittee agrees that the indemnification obligations assumed under this Permit shall survive expiration of the Permit or completion of work.

Permittee shall obtain and maintain through the terms of this Permit general liability, automobile liability or workers' compensation insurance as the City deems necessary to protect the City against claims for damages for personal injury, accidental death and property damage allegedly arising from any work done under this Permit. Such insurance shall in no way limit Permittee's indemnity hereunder. Certificates of insurance, in form and with insurers satisfactory to the City, evidencing all coverages above shall be furnished to the City before commencing any operations under this Permit, with complete copies of policies furnished promptly upon City request.

5. Permittee will, at its own expense, maintain in full force and effect an insurance policy or policies issued by and insurance company or companies satisfactory to the City's Controller and written by an insurance company or companies having a policy holders surplus of at least Twenty Million Dollars (\$20,000,000) or if insurance is written by more than one company, each company shall have policy holders surplus of at least ten times the amount insured.

Policy or policies shall afford liability insurance covering all operations, including but not limited to premises (definition of "premises" to be expanded to include this encroachment), products, personal injuries and automobiles and injury to property for single limit of not less than Two Million Dollars (\$2,000,000) applying to bodily injuries, personal injuries and property damage or a combination of such injuries. Said policy or policies shall include the City and County of San Francisco and its

officers and employees jointly and severally as additional insured and shall apply as primary insurance and shall stipulate that no other insurance affected by the City and County of San Francisco will be called on to contribute to a loss covered hereunder. Said policy or policies shall provide thirty (30) days notice to Controller, City and County of San Francisco, 1 Dr. Carlton B. Goodlett Place, San Francisco, CA 94102, if the policy or policies should be canceled or materially changed. The permission granted by said resolution shall automatically terminate upon the termination of such insurance. Upon such termination, Permittee shall restore the right-of-way, without expense to the "Personal Injuries", as used herein, shall include wrongful death.

6. The permittee shall obtain a building permit as the Central Permit Bureau, 1660 Mission Street for the construction or alteration of any building.
7. The permittee shall contact the Street Permit Section (415) 554-5810, at least 48 hours prior to starting work to arrange an inspection schedule.
8. The permittee acknowledge its responsibility to notify any successor owners of the existence of the encroachment and the successor owner's obligation to obtain a permit from the Department of Public Works 60 days in advance of any pending sale of the permittee's adjacent property. The permittee's obligation to remove the encroachment and restore the right-of-way to a condition satisfactory to the Department of Public Works shall survive the revocation, expiration or termination of this permit or sale of permittee's adjacent property.
9. The permittee's right to use City property, as set forth in this permit is appurtenant to the property described as: Partimereed, corner of Lakeview
Blud and Figueroa Ave in the Median Island
_____ The provisions of the permit shall bind all subsequent purchases and owners of the described property.

Subsequent purchasers and owners shall be subject to the revocation and termination provisions set forth in this permit.

10. The permittee or subsequent owners recognize and understand that this permit may create a possessory interest subject to property taxation and that the permittee or subsequent owner or owners may be subject to the payment of such taxes.
11. The permittee or subsequent owner or owners recognize the recordation of this permit.

All of the provisions of this agreement shall be deemed provisions of said resolution. All of the provisions of said resolution shall be deemed provisions of this agreement.

In witness whereof the undersigned Permittee(s) have executed this agreement this 10 day of June, 2010.

California All-Purpose Acknowledgement

State of California }
County of SAN FRANCISCO

On 6/10/2010 before me, KRISTINE D. BAKER, a Notary Public
personally appeared ADAM RON MAYER

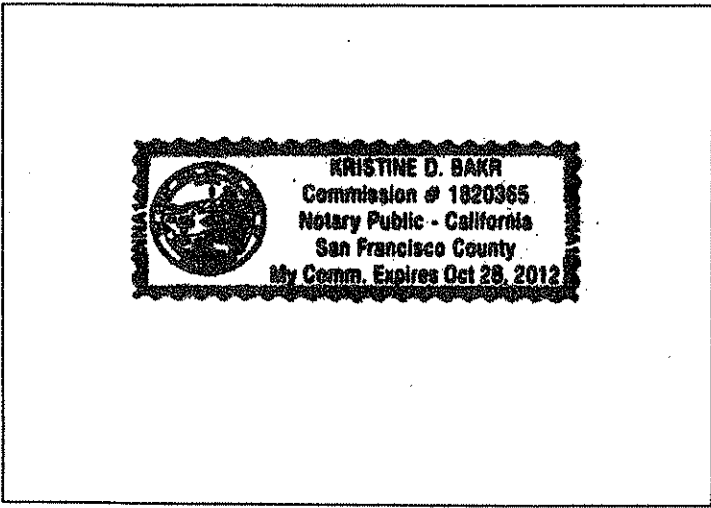

Notary Public Seal

who proved to me on the basis of satisfactory evidence to be the person(s) whose name(s) is/are subscribed to the within instrument and acknowledged to me that he/she/they executed the same in his/her/their authorized capacity(ies), and that by his/her/their signature(s) on the instrument the person(s), or the entity upon behalf of which the person(s) acted, executed the instrument. I certify under PENALTY OF PERJURY under the laws of the State of California that the foregoing paragraph is true and correct.

WITNESS my hand and official seal.

Kristine Baker

Notary Public Signature

OPTIONAL

Description of Attached Document

Title or Type of Document: PARALLEL STREET ENCROACHMENT AGREEMENT

Document Date: 6/10/2010 Number of Pages: 3

Signer(s) Other than Named Above: _____

Capacity(ies) Claimed by Signer(s)

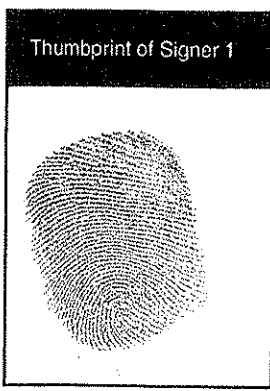

Individual
 Corporate Officer: _____
 Partner - Limited General
 Attorney-in-Fact
 Trustee
 Guardian or Conservator
 Other: _____
Signer is Representing: _____

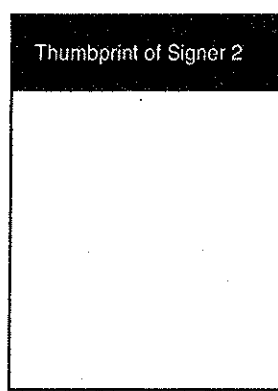

Individual
 Corporate Officer: _____
 Partner - Limited General
 Attorney-in-Fact
 Trustee
 Guardian or Conservator
 Other: _____
Signer is Representing: _____

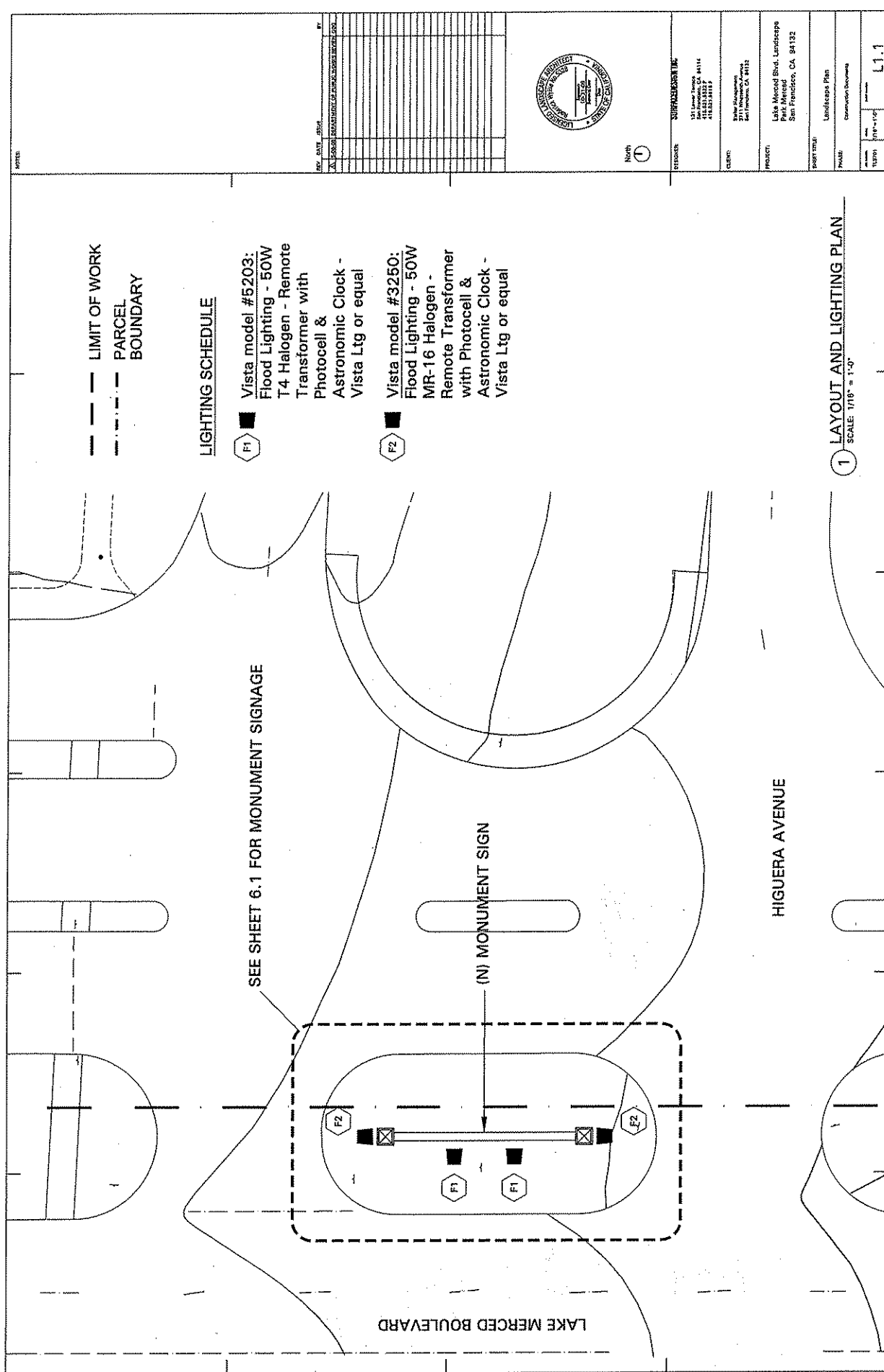

--- LIMIT OF WORK
 - . - . - . PARCEL BOUNDARY

LIGHTING SCHEDULE

- F1
 Vista model #5203:
 Flood Lighting - 50W
 T4 Halogen - Remote
 Transformer with
 Photocell &
 Astronomic Clock -
 Vista Ltg or equal

- F2
 Vista model #3250:
 Flood Lighting - 50W
 MR-16 Halogen -
 Remote Transformer
 with Photocell &
 Astronomic Clock -
 Vista Ltg or equal

SEE SHEET 6.1 FOR MONUMENT SIGNAGE

(N) MONUMENT SIGN

HIGUERA AVENUE

LAKE MERCED BOULEVARD



North

DESIGNER:	SUPERLUMEN INC.
CLIENT:	Lake Merced Blvd, Landscape Paul Merced San Francisco, CA, 94132
PROJECT:	Lake Merced Blvd, Landscape Paul Merced San Francisco, CA, 94132
DATE:	11/16/10
SCALE:	1" = 1'-0"
SHEET NO.:	1.1

1 LAYOUT AND LIGHTING PLAN
 SCALE: 1/16" = 1'-0"

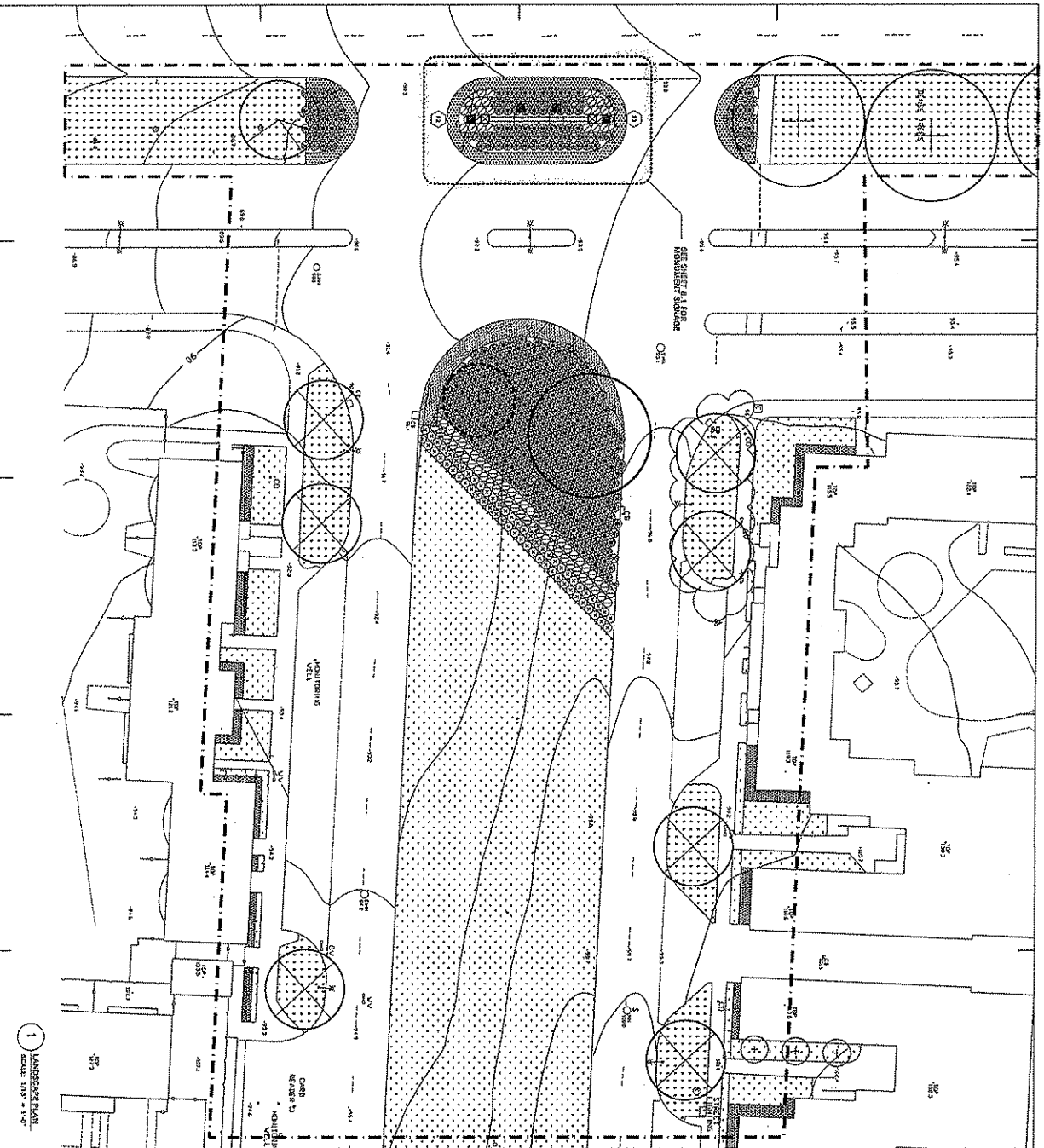

1 LANDSCAPE PLAN
SCALE: 1/8" = 1'-0"

LEGEND

--- LIMIT OF WORK

PLANTING SCHEDULE

- ① 90' DIVER PAVILION CHINA Elm
1 GAL QUANTITY: 10
SPACING: PER PLAN
- ② Malibu/Myrtle Almond Plant Grass
1 GAL QUANTITY: 750
SPACING: 30' O.C.
- ③ Callery/Myrtle Almond Plant Grass
1 GAL QUANTITY: 145
SPACING: 30' O.C.
- ④ Monterey Cypress Plant Grass
5 GAL QUANTITY: 124
SPACING: 30' O.C.
- ⑤ Casahuate/Myrtle Almond Plant Grass
1 GAL QUANTITY: 224
SPACING: 30' O.C.
- ⑥ Other Various Plantings
1 GAL QUANTITY: 2199 SF
SPACING: 30' O.C.
- ⑦ Ficus Plant Grass
1 GAL QUANTITY: 26,380
SPACING: 30' O.C.
- ⑧ Las Olivas Plant Grass
1 GAL QUANTITY: 28,380
SPACING: 30' O.C.
- ⑨ Total Area to be Planted: 68,576 SF

LIGHTING

- ① VISA model 4323C
Flood Lighting - 65W 1/4 Halogen - Barnack
Transformer with Photocell & Astronomic Clock
VISA 1/4 or equal
- ② VISA model 4325C
Flood Lighting - 65W 1/4 Halogen - Barnack
Transformer with Photocell & Astronomic Clock
VISA 1/4 or equal

NOTES:

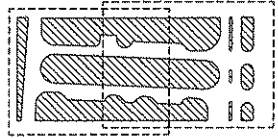

PROJECT: Lark Landing Blvd, Landscape
Park Record
San Francisco, CA 94132

CLIENT: Lark Landing Blvd, Landscape
Park Record

DATE: 1/13/13

SCALE: 1/8" = 1'-0"

PROJECT NO.: L1.3

NOTE:

- 1. All work shall be performed in accordance with the latest editions of the applicable codes and standards.

REV	DATE	DESCRIPTION	BY	CHKD



REGISTERED PROFESSIONAL ENGINEER
 DAVID H. JOHNSON
 License No. 91270
 State of California

PROJECT:
 LANE MERCED ENTRY MONUMENT

CLIENT:
 LANE MERCEDES, INC.
 2111 University Avenue
 San Francisco, CA 94112

DATE:
 08/01/01

SCALE:
 AS SHOWN

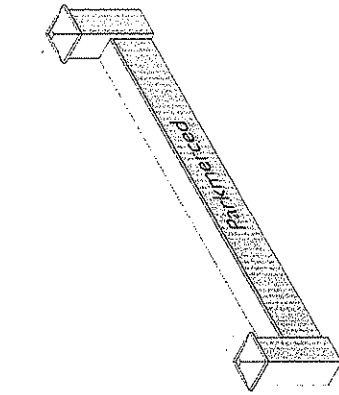

2 ISOMETRIC VIEW OF MONUMENT
 SCALE: 1/8" = 1'-0"

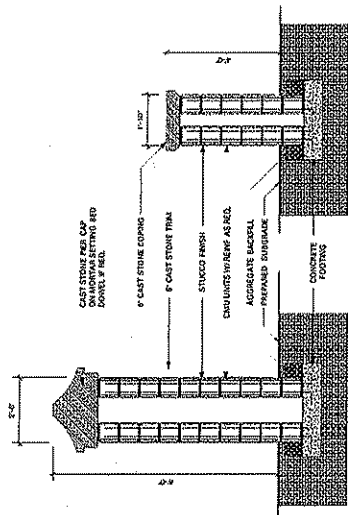

4 MONUMENT DETAIL @ WALL
 SCALE: 1/2" = 1'-0"

5 MONUMENT DETAIL @ PIER
 SCALE: 1/2" = 1'-0"

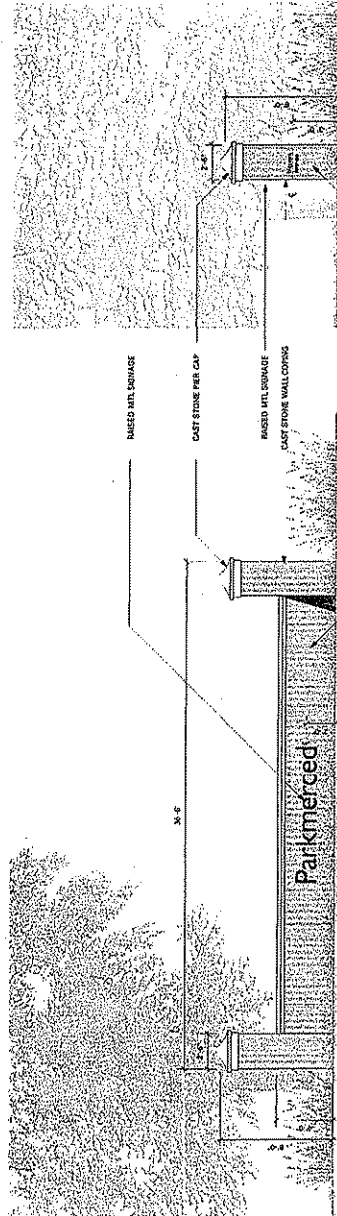

1 LANE MERCED ENTRY MONUMENT SIDE ELEVATION
 SCALE: 1/8" = 1'-0"

3 LANE MERCED ENTRY MONUMENT FRONT ELEVATION
 SCALE: 1/8" = 1'-0"