

From: [Sonja Trauss](#)
To: [Board of Supervisors, \(BOS\)](#); [Melgar, Myrna \(BOS\)](#); [Haney, Matt \(BOS\)](#); [MandelmanStaff, \[BOS\]](#)
Subject: 450 O'Farrell, don't adopt the findings
Date: Monday, December 13, 2021 7:37:58 PM
Attachments: [450 O'Farrell Findings - HAA Letter - 12-13-2022.pdf](#)

This message is from outside the City email system. Do not open links or attachments from untrusted sources.

12/13/2021

San Francisco Board of Supervisors
1 Dr. Carlton B. Goodlett Place - City Hall, Room 244
San Francisco, CA 94102

Board.of.Supervisors@sfgov.org

Via Email

Re:

Item 42, File No. 42. 211274 [[Findings Related to Conditional Use Authorization - 450-474 O'Farrell Street and 532 Jones Street](#)]

Motion adopting findings in support of the Board of Supervisors' disapproval of the decision of the Planning Commission by its Motion No. 20935, approving a Planned Unit Development and Conditional Use Authorization, identified as Planning Case No. 2013.1535CUA-02, for a proposed project located at 450-474 O'Farrell Street and 532 Jones Street.

Dear San Francisco Board of Supervisors,

YIMBY Law submits this letter to discourage you from adopting the above referenced findings. As we have informed you previously, the Housing Accountability Act (HAA) only permits cities to evaluate proposed housing development using objective findings, and does not permit cities to disapprove projects or approve them at a lower density based on subjective findings. All of the findings you will be considering today are subjective or don't reference an "applicable, objective general plan and zoning standards [or] criteria". In addition, some of the findings are inaccurate and some of them, frankly, are embarrassing.

The San Francisco zoning code permits up to 13 stories at 450 O'Farrell with a conditional use permit. Fortunately for the cause of abundant housing, and unfortunately for local discretion, San Francisco's criteria for receiving a conditional use permit are all subjective. Correspondingly, as mentioned above, none of the findings are objective or reference objective criteria required for receiving a conditional use permit.

If San Francisco would like to continue to use the Conditional Use process to allow different outcomes for different types of projects, the Board of Supervisors must pass ordinances creating objective criteria for receiving Conditional Use permits.

The first several findings on pages 3 and 4 attempt to justify denying the CU for 13 stories based on the fact that the proposed units are small and don't have full kitchens. However, there is no existing zoning plan standard or criteria requiring a minimum unit size or a full kitchen in order to receive a Conditional Use permit. Therefore, this finding can't be used as a justification for denying the Conditional Use permit.

In addition, the reasoning in this section is weak. In San Francisco 38% of adults, and 60% of all renters, live with roommates (this does not include married couples). These adults share 2,3 and 4 bedroom apartments with each other. At least some of them would prefer to live alone. Insofar as the future residents of the proposed studio apartments at 450 O'Farrell would be moving out of roommate situations (or not entering into them in the first place), these studios would, in fact, be meeting the city's need for more larger units.

The Board of Supervisors is also going to be voting on findings to delay almost 500 apartments at 469 Stevenson today, all of which have full kitchens, and most of which have 2 or more bedrooms. It is hard for the public to understand why the SF Board of Supervisors would deny this Conditional Use permit because the proposed housing units are too small, and also vote to delay - possibly fatally- another proposed project that has larger units, *on the same day*. If the purpose of adopting these findings is to encourage larger apartments with full kitchens, then why would the Board also vote to frustrate a project that actually has larger apartments with full kitchens?

The next type of finding, on page 5, starting on line 5 is that the CU should be denied because the residents will cause traffic by ordering food delivery. There is also a finding on page 6, line 1 that small units will cause a lot of TNC use. Again, there is no objective standard for the CU regarding traffic, or rates of food delivery, or rates of TNC use so this finding cannot be used to justify reducing the density of the proposed project. Moreover, this line of reasoning is speculative and not supported by any data or modeling.

The most embarrassing finding is on page 6, lines 13 to 18. It is so astonishing, we will copy it here.

WHEREAS, Appellants have provided evidence of a glut of similar small units without full kitchens in the Tenderloin/mid-Market area; the Panoramic development at 1321 Mission Street is an example of this glut, the Panoramic, which consists of efficiency units that do not have full kitchens, and that lack stoves, full-size refrigerators and adequate food storage and preparation space, has high vacancy rates and has been unsuccessful, and is being marketed for sale;

The Board surely recalls that just weeks ago, on Oct 19, it approved the purchase of the Panoramic, to be used as housing for formerly homeless individuals and families.

If the proposed housing at 450 O'Farrell project wound up in the same position as the Panoramic - available for San Francisco to buy and use as low income housing - this would be a great benefit to San Francisco, and is a compelling reason to **approve** the conditional use permit.

The last finding, on page 6 line 19, that residents of this project won't be "long term permanent residents" and will therefore be unlikely to "volunteer for and contribute to the community, advocate for community improvements, and serve as eyes on the street" is speculative, unsupported and frankly insulting to the thousands of residents of the Tenderloin who live in studio apartments and

are active in the Tenderloin community.

The project proposed at 450 O'Farrell Street would demolish three existing buildings and construct a mixed use building up to 13-stories on O'Farrell and Shannon Streets and up to 4-stories on Jones Street. The project currently includes 316 group housing rooms with a maximum of 632 group housing beds; 48 of the rooms are designated to be rented at below-market rates.

The project was entitled by the Planning Commission at their September 13, 2018 meeting, and a revised application was approved again at their June 24, 2021 hearing with Conditions as amended to include: 1. Increase the number of larger group housing units, wherever feasible; 2. Provide balconies to maximum projection on all sides except O'Farrell Street; 3. Continue working with Staff to increase the number of bicycle parking spaces, up to 200; 4. Convert the ground-floor retail space to group housing units; and 5. Work with Staff to analyze the feasibility of converting the basement to additional group housing units.

An appeal letter was filed by the Tenderloin Housing Clinic and Pacific Bay Inn, Inc. on July 21, 2021. The Appeal Letter challenges previous actions that were not part of the June 24, 2021 action by the Planning Commission. Specifically, the appeal is based on objections to alleged construction impacts and the authorization for group housing at this site. None of the reasons stated as the basis for the appeal concern the items modified by the Planning Commission action. Nothing in the action of the Planning Commission affects the previously approved site plan and associated construction impacts, and group housing is a permitted use in this zoning district, requiring no Planning Commission or Board of Supervisors approval.

The amended Conditional Use Authorization which was approved by the Planning Commission falls well within the bounds of the General Plan. Even expanding our view to the project's previous approvals, including specific items within the Planned Unit Development, nothing proposed or adopted is outside the scope of the city's general plan to conclude that the project is not protected by the Housing Accountability Act. As the project is subject to protection under the HAA, the City is limited both in the actions it may take on the project and the number of hearings the project may be subjected to.

Conclusion

This project must be treated as any other project would be under the HAA. This means that the Board of Supervisor's discretion is limited in this case. The project does not pose a threat to public health and safety and complies with every objective General Plan standard. Not only was this project approved by Planning Commission on June 34, 2021, it has already been entitled previously, with very similar characteristics, on September 13, 2018.

The Board of Supervisors should NOT adopt these findings. If these findings are not adopted, the Planning Commission's approval will stand, and San Francisco will avoid a costly lawsuit.

Yimby Law is a 501(c)3 non-profit corporation, whose mission is to increase the accessibility and affordability of housing in California.

I am signing this letter both in my capacity as the Executive Director of YIMBY Law, and as a resident of California who is affected by the shortage of housing in our state.

Sincerely,



Sonja Trauss
Executive Director
YIMBY Law



12/13/2021

San Francisco Board of Supervisors
1 Dr. Carlton B. Goodlett Place - City Hall, Room 244
San Francisco, CA 94102

Board.of.Supervisors@sfgov.org
Via Email

Re:

Item 42, File No. 42. 211274 [[Findings Related to Conditional Use Authorization - 450-474 O'Farrell Street and 532 Jones Street](#)]

Motion adopting findings in support of the Board of Supervisors' disapproval of the decision of the Planning Commission by its Motion No. 20935, approving a Planned Unit Development and Conditional Use Authorization, identified as Planning Case No. 2013.1535CUA-02, for a proposed project located at 450-474 O'Farrell Street and 532 Jones Street.

Dear San Francisco Board of Supervisors,

YIMBY Law submits this letter to discourage you from adopting the above referenced findings. As we have informed you previously, the Housing Accountability Act (HAA) only permits cities to evaluate proposed housing development using objective findings, and does not permit cities to disapprove projects or approve them at a lower density based on subjective findings. All of the findings you will be considering today are subjective or don't reference an "applicable, objective general plan and zoning standards [or] criteria". In addition, some of the findings are inaccurate and some of them, frankly, are embarrassing.

The San Francisco zoning code permits up to 13 stories at 450 O'Farrell with a conditional use permit. Fortunately for the cause of abundant housing, and unfortunately for local discretion, San Francisco's criteria for receiving a conditional use permit are all subjective. Correspondingly, as mentioned above, none of the findings are objective or reference objective criteria required for receiving a conditional use permit.

If San Francisco would like to continue to use the Conditional Use process to allow different outcomes for different types of projects, the Board of Supervisors must pass ordinances creating objective criteria for receiving Conditional Use permits.

The first several findings on pages 3 and 4 attempt to justify denying the CU for 13 stories based on the fact that the proposed units are small and don't have full kitchens. However, there is no existing zoning plan standard or criteria requiring a minimum unit size or a full kitchen in order to receive a Conditional Use permit. Therefore, this finding can't be used as a justification for denying the Conditional Use permit.

In addition, the reasoning in this section is weak. In San Francisco 38% of adults, and 60% of all renters, live with roommates (this does not include married couples).¹ These adults share 2,3 and 4 bedroom apartments with each other. At least some of them would prefer to live alone. Insofar as the future residents of the proposed studio apartments at 450 O'Farrell would be moving out of roommate situations (or not entering into them in the first place), these studios would, in fact, be meeting the city's need for more larger units.

The Board of Supervisors is also going to be voting on findings to delay almost 500 apartments at 469 Stevenson today, all of which have full kitchens, and most of which have 2 or more bedrooms. It is hard for the public to understand why the SF Board of Supervisors would deny this Conditional Use permit because the proposed housing units are too small, and also vote to delay - possibly fatally- another proposed project that has larger units, *on the same day*. If the purpose of adopting these findings is to encourage larger apartments with full kitchens, then why would the Board also vote to frustrate a project that actually has larger apartments with full kitchens?

The next type of finding, on page 5, starting on line 5 is that the CU should be denied because the residents will cause traffic by ordering food delivery. There is also a finding on page 6, line 1 that small units will cause a lot of TNC use. Again, there is no objective standard for the CU regarding traffic, or rates of food delivery, or rates of TNC use so this finding cannot be used to justify reducing the density of the proposed project. Moreover, this line of reasoning is speculative and not supported by any data or modeling.

The most embarrassing finding is on page 6, lines 13 to 18. It is so astonishing, we will copy it here.

¹

<https://sf.curbed.com/2017/12/18/16791954/san-francisco-roommates-double-households-rent-data>

WHEREAS, Appellants have provided evidence of a glut of similar small units without full kitchens in the Tenderloin/mid-Market area; the Panoramic development at 1321 Mission Street is an example of this glut, the Panoramic, which consists of efficiency units that do not have full kitchens, and that lack stoves, full-size refrigerators and adequate food storage and preparation space, has high vacancy rates and has been unsuccessful, and is being marketed for sale;

The Board surely recalls that just weeks ago, on Oct 19, it approved the purchase of the Panoramic, to be used as housing for formerly homeless individuals and families.²

If the proposed housing at 450 O'Farrell project wound up in the same position as the Panoramic - available for San Francisco to buy and use as low income housing - this would be a great benefit to San Francisco, and is a compelling reason to **approve** the conditional use permit.

The last finding, on page 6 line 19, that residents of this project won't be "long term permanent residents" and will therefore be unlikely to "volunteer for and contribute to the community, advocate for community improvements, and serve as eyes on the street" is speculative, unsupported and frankly insulting to the thousands of residents of the Tenderloin who live in studio apartments and are active in the Tenderloin community.

The project proposed at 450 O'Farrell Street would demolish three existing buildings and construct a mixed use building up to 13-stories on O'Farrell and Shannon Streets and up to 4-stories on Jones Street. The project currently includes 316 group housing rooms with a maximum of 632 group housing beds; 48 of the rooms are designated to be rented at below-market rates.

The project was entitled by the Planning Commission at their September 13, 2018 meeting, and a revised application was approved again at their June 24, 2021 hearing with Conditions as amended to include: 1. Increase the number of larger group housing units, wherever feasible; 2. Provide balconies to maximum projection on all sides except O'Farrell Street; 3. Continue working with Staff to increase the number of bicycle parking spaces, up to 200; 4. Convert the ground-floor retail space to group housing units; and 5. Work with Staff to analyze the feasibility of converting the basement to additional group housing units.

An appeal letter was filed by the Tenderloin Housing Clinic and Pacific Bay Inn, Inc. on

²

<https://hoodline.com/2021/10/supes-approve-panoramic-apartments-for-homeless-housing-despite-community-pushback/>

July 21, 2021. The Appeal Letter challenges previous actions that were not part of the June 24, 2021 action by the Planning Commission. Specifically, the appeal is based on objections to alleged construction impacts and the authorization for group housing at this site. None of the reasons stated as the basis for the appeal concern the items modified by the Planning Commission action. Nothing in the action of the Planning Commission affects the previously approved site plan and associated construction impacts, and group housing is a permitted use in this zoning district, requiring no Planning Commission or Board of Supervisors approval.

The amended Conditional Use Authorization which was approved by the Planning Commission falls well within the bounds of the General Plan. Even expanding our view to the project's previous approvals, including specific items within the Planned Unit Development, nothing proposed or adopted is outside the scope of the city's general plan to conclude that the project is not protected by the Housing Accountability Act. As the project is subject to protection under the HAA, the City is limited both in the actions it may take on the project and the number of hearings the project may be subjected to.

Conclusion

This project must be treated as any other project would be under the HAA. This means that the Board of Supervisor's discretion is limited in this case. The project does not pose a threat to public health and safety and complies with every objective General Plan standard. Not only was this project approved by Planning Commission on June 30, 2021, it has already been entitled previously, with very similar characteristics, on September 13, 2018.

The Board of Supervisors should NOT adopt these findings. If these findings are not adopted, the Planning Commission's approval will stand, and San Francisco will avoid a costly lawsuit.

Yimby Law is a 501(c)3 non-profit corporation, whose mission is to increase the accessibility and affordability of housing in California.

I am signing this letter both in my capacity as the Executive Director of YIMBY Law, and as a resident of California who is affected by the shortage of housing in our state.

Sincerely,

A handwritten signature in black ink that reads "Sonja Trauss". The signature is written in a cursive, flowing style.

Sonja Trauss

Executive Director
YIMBY Law

From: Reena.Kaur@hklaw.com
To: [Cityattorney](#); [Board of Supervisors. \(BOS\)](#)
Cc: Divya.Sen@hcd.ca.gov; housing@doj.ca.gov; senator.wiener@senate.ca.gov; david.murray08@gmail.com; ela@elastrong.com; davidc@dpclawoffices.com; pick@storzerlaw.com; storzer@storzerlaw.com; sonja@yimbylaw.org; Daniel.Golub@hklaw.com; Letitia.Moore@hklaw.com; Melanie.Chaewsky@hklaw.com
Subject: Correspondence 1 of 2 re 450-474 O'Farrell Street/532 Jones Street Project Application Case No. 2013.1535EIA-02
Date: Tuesday, December 14, 2021 1:04:32 PM
Attachments: [2021-12-14 Letter re 450 \[1 of 2\].pdf](#)

Dear Counsel,

Please see the attached letter from Holland & Knight LLP regarding the 450-474 O'Farrell Street/532 Jones Street Project Application, Case No. 2013.1535EIA-02. Please ensure that this correspondence and its attachments are included in the record of proceedings for the above-captioned matter and are provided to the Board of Supervisors for the December 14 hearing on this matter. Due to the size of the letter, it has been split into two parts. Part 1 of 2 is attached here.

Thanks,

Reena Kaur | Holland & Knight

Practice Assistant

Holland & Knight LLP

50 California Street, Suite 2800 | San Francisco, California 94111

Phone 415.743.6916 | Fax 415.743.6910

reena.kaur@hklaw.com | www.hklaw.com

Holland & Knight

50 California Street, Suite 2800 | San Francisco, CA 94111 | T 415.743.6900 | F 415.743.6910
Holland & Knight LLP | www.hklaw.com

Daniel R. Golub
+1 415-743-6900
Daniel.Golub@hklaw.com

December 14, 2021

Via email: cityattorney@sfcityatty.org
David Chiu
City Attorney
City Hall
1 Dr. Carlton B. Goodlett Place, Room 244
San Francisco, CA 94102-4689

Via email: Board.of.Supervisors@sfgov.org
Angela Calvillo
Clerk of the Board of Supervisors
City Hall
1 Dr. Carlton B. Goodlett Place, Room 244
San Francisco, CA 94102-4689

Re: **450-474 O'Farrell Street/532 Jones Street Project Application**
Case No. 2013.1535EIA-02

Dear Mr. Chiu and Ms. Calvillo:

Please ensure that this correspondence and its attachments are included in the record of proceedings for the above-captioned matter and are provided to the members of the Board of Supervisors for the December 14 hearing on this matter.

Holland & Knight LLP has been retained to represent Fifth Church of Christ, Scientist and Forge Development Partners (the "Applicants") to protect their rights under California housing law for the 450-474 O'Farrell Street/532 Jones Street Project.¹ As we described in our many prior communications in the record, the Project is fully protected under numerous state housing laws, including but not limited to the Housing Accountability Act ("HAA"), the Housing Crisis Act (also known as SB 330), and the Permit Streamlining Act. As you are aware, the California Department of Housing and Development ("HCD") wrote to the City and County of San Francisco ("City") on November 22 to express HCD's concern that disapproving this Project would violate state housing law.

Despite this clear warning from the state agency delegated by the Legislature with "primary responsibility for development and implementation of housing policy," Cal. Health & Safety Code § 50152, the draft findings to disapprove this Project take the approach of completely disregarding HCD's concerns and disapproving the Project in direct violation of state housing law. Leading experts in housing law agree. Christopher Elmendorf, Martin Luther King, Jr.

¹ The Applicant is also represented by David Cincotta as well as Storzer & Associates, P.C. in connection with the Religious Land Use and Institutionalized Persons Act (RLUIPA) and other federal laws. This letter focuses on violations of California housing law, but the Applicant also reserves its right to enforce RLUIPA and other federal laws.

Professor of Law at UC Davis School of Law puts it flatly: “[a] vote to pass the *O’Farrell motion is a vote to violate the Housing Accountability Act.*” (see attachments).

We have only had a limited opportunity to review the draft resolution, which was posted for the first time little more than one business day before the Board was scheduled to vote on it. However, even on initial review it is clear that the findings in that resolution would not suffice even under the traditional legal standard that is typically deferential to cities. But this Project, of course, is *not* subject to the normal legal standard. As a housing development project, the Project is subject to the HAA, which two different divisions of the First District Court of Appeal have held must be interpreted *without* deference to local governments, and instead interpreted to give “the fullest possible weight to the interest of, and the approval and provision of, housing.” California Renters Legal Advoc. & Educ. Fund v. City of San Mateo (2021) 68 Cal. App. 5th 820, 854 (*quoting* Gov. Code § 65589.5(a)(2)(L)); Ruegg & Ellsworth v. City of Berkeley (2021) 63 Cal. App. 5th 277, 296, *reh’g denied* (May 19, 2021), *review denied* (July 28, 2021). The gravamen of the HAA is to require cities to advance code-compliant housing developments such as the Project on the basis of the objective standards in a city’s current code – and to prohibit those projects from being denied for the type of subjective considerations and arbitrary policy preferences described in the draft resolution.

The City knows this Project is fully code-compliant, which is why it is apparently considering new regulations that might regulate “group housing” differently. *See* “Exclusive: New Peskin ordinance would clarify group housing definition,” S.F. BUSINESS TIMES (Dec. 13, 2021) (see attachments). As the City acknowledges, however, “[c]urrent projects already proposed in the pipeline are not affected by this.” *Ibid.*; *see also* Gov. Code § 65589.5(j) (HAA only permits application of objective standards “in effect at the time that the application was deemed complete”). These Applicants have invested heavily in developing a Project in full compliance with all State and City legal requirements as they exist today – which the HAA, among other laws, requires the City to honor. The Board of Supervisors apparently plan to disapprove this fully code-compliant Project because some Board members would prefer that the code be different than it is. This would be mockery of basic principles of land use and planning. In combination with the other facts in the record, it is also a “bad faith” disapproval of housing, subjecting the City to enhanced fines of \$50,000 per home, and an order directing the approval of the Project. Gov. Code § 65589.5(k), (l).

We strongly urge the Board not to take the unlawful act of disapproving these much-needed new homes at a time of a devastating housing supply crisis.

I. The Findings Are Arbitrary and Capricious and Unsupported by Substantial Evidence.

Even under the ordinary legal standard that applies outside of the context of state housing law, a local agency’s decision is unlawful if the decision is arbitrary, capricious, or unsupported by substantial evidence. *See* Code Civ. Proc. § 1094.5(c); *see also* Ruegg & Ellsworth v. City of Berkeley (2021) 63 Cal. App. 5th 277, 298, *reh’g denied* (May 19, 2021), *review denied* (July 28, 2021). Most of the draft findings consist of *post hoc* rationalizations that were not articulated by the Board members when they voted to disapprove the Project in October. As we explained in

our prior letter, these *post hoc* rationalizations will not be considered in judicial proceedings challenging the Board’s decision. But even putting this aside, the draft findings before the Board do not rescue the Board’s decision from being arbitrary and capricious, and neither do the draft findings provide any substantial evidence to support the disapproval of this housing development. The findings consist of arbitrary opinion, clearly erroneous assertions, and contentions that are at odds with the record. Most importantly, other completely indistinguishable “group housing” development projects have been approved in the immediate vicinity without ever being subject to the objections that have prompted the Board to disapprove this Project (see, e.g. the 468 Turk Street and 300 De Haro Steet project files, which are on file with the City and hereby incorporated by reference) (see attachments). The Board’s decision to disapprove this particular group housing development instead of others can only be described as arbitrary and capricious decision-making.

To begin with, the draft findings refer to Pacific Bay Inn, Inc. (who appealed on CEQA issues) and Tenderloin Housing Clinic (who appealed on non-CEQA grounds) as the “Appellants” who challenged the Planning Commission’s approval of the Project. But the draft resolution does not disclose the fact that – as was stated in the hearing – Pacific Bay Inn, Inc. withdrew its appeal before the hearing, and that only Tenderloin Housing Clinic’s appeal was before the Board when the Board voted to grant it.

The draft resolution cites a 2017 “Housing for Families with Children” report that was produced at the October 5 hearing only after public comment had closed, and was never presented to the Applicants. But this report only supports approval of the Project. The report identifies the requirements and components that development should provide to meet neighborhood needs – such as two bedrooms of an average size of 850 sf or less, to avoid larger units that are “too expensive.” The Project as proposed *meets and exceeds* all of these Planning Commission-identified criteria in the report.

The draft resolution inaccurately claims that the Department of Building Inspection Annual Unit Usage Report (“AUUR”) shows a high vacancy rate in group housing projects. The AUUR provides information collected from residential hotels under the San Francisco Residential Hotel Unit Conversion and Demolition Ordinance. Those residential hotels have none of the support programs, design features, open space elements, and amenities of the proposed Project. Additionally, the draft resolution relies on the Appellant having “provided testimony that there is significant overcrowding of families in small units in the Tenderloin neighborhood,” but cites no evidence beyond this assertion. The “overcrowding” referred to are illegal practices, which the law specifically forbids from occurring in the Project. As shown in the materials before the Board, “group occupancy” has a lower restricted density for maximum occupancy than a non-group occupancy project of similar area. Most importantly, it is shocking that the City, at a time of an extreme housing supply crisis, would suggest that it would be appropriate to not create *any* homes at the Project site, out of a concern about overcrowded homes nearby. Increasing the supply of available housing, of course, could only assist with overcrowded conditions.

The findings go on to cite the “small size and lack of full kitchen facilities,” and lack of food storage, despite the Project’s undisputed compliance with all related code and state law requirements that the City and state have established as necessary to ensure adequate service for

children and families. The Project application materials show that cooking facilities are provided in each and every unit, in a manner used in housing projects around the world and throughout the City. The Project has sinks, refrigerators, cooktops, multi-phase convection ovens, dishwashers, garbage disposals, and all code-required food storage. The appliances provided for each unit are suitable for the preparation of a multi-course meal including a 12 pound turkey. As part of the Applicants' commitment to aggressive implementation of social equity programs, the Applicants' partner, Project Access, will also provide extensive on-site social services to the residents, including after school and day programs for the children of residents – in addition to the open space, dedicated storage, and other services not normally found in traditional multifamily housing. Project Access provides program that “connect, engage and empower” residents to “cultivate strong communities.” Project Access also provides training, classes and hands on experience for residents to support their healthy life thru nutrition. Under State and City codes, the Project is only required to provide one group kitchen, but the Project will provide *six*, distributed throughout the Project. This Project will provide 322 cooking facilities and meets all codes and zoning requirements. Nothing in the draft resolution findings supports a finding that the Project will be inadequate to support families.

Furthermore, in the “most walkable large city in the [United States],” in the Tenderloin, a San Francisco neighborhood with a Walk Score of 100, a Transit Score of 100, and a Bike Score of 91, the draft resolution asserts, with no factual basis, that because of the unit sizes, the Project will lead to high volume use of Uber and Lyft Transportation Network Company (“TNC”) services and food delivery services, which would lead to increased congestion and associated pedestrian-vehicle collisions and air pollution. Although the draft resolution references the Walk San Francisco Annual Report Card for the Tenderloin 2016-2020, the resolution fails to note that the Annual Report Card shows that O’Farrell corridor has the least overall number of injury crashes in the Tenderloin. The draft resolution also does not identify that the City concluded that the Project would have a less than significant impact on transit and transportation. Second Addendum to Environmental Impact Report., p. 22. Nor does the draft resolution acknowledge the City’s Transit-First Policy statement that reduction of “traffic congestion depends on the adequacy of regional public transportation.” San Francisco Charter Sec. 8A.115(a)(9) Instead, the draft resolution seeks to address erroneous assertions about traffic congestion, traffic safety and air pollution from TNCs and food delivery vehicles by prohibiting housing.

Although the draft resolution states that the Tenderloin neighborhood is best served by long-term permanent residents, the Board carelessly dismisses the Fifth Church of Christ, Scientist long-term residency and community service. The Church has occupied this site for 100 years. An active member of the community and advocate for services and benefits for the Tenderloin neighborhood since inception, its mission is to improve the life of the community and specifically the immediate neighborhood. In addition to its partnership with Project Access, the Church works with its immediate neighbors and Simon Bertang, Executive Director, Tenderloin Community Benefit District, to bring program and services to the Tenderloin neighborhood. The draft resolution blindly ignores the Church and others in the community who, with demonstrated long-term commitment to and service in the Tenderloin, provided public comment on how the Project could benefit the neighborhood.

Finally, and perhaps most remarkable of all, the proposed resolution would seek to justify disapproval of the Project out of a concern for “a glut of similar small units” in nearby projects, citing “the Panoramic development at 1321 Mission Street” as an example which the draft resolution claims has not been successful. Nothing in the law supports a city’s decision to prevent a lawfully permitted use on the grounds that the city believes the use will not be marketable. The Applicants, of course, are the ones with the vested financial interest in the Project’s success, and are the ones bearing the risk that the Project will succeed financially. But in any event, the example of the Panoramic is inapt. The Panoramic was master-leased to two schools as student housing, and suffered financially, like many other student housing development when the schools closed during the pandemic. The fact that the Panoramic did not succeed as student housing does not support the contention that this Project will not succeed. A different, more comparable project, on Twelfth Street, is performing well. But even accepting *arguendo* that the Board has some concern about whether the Project’s units will be marketable, this does not justify halting the construction of the Project. After all, although the draft resolution notes that the Panoramic has been “is being marketed for sale,” it does not disclose that *the City itself is the entity that bought the Panoramic* (among other former hotels), and that the City plans to use the units to meet part of the City’s homeless and affordable housing needs (see attachments). If this Project were to meet a similar fate as the Panoramic, the City would find itself in a position of being able to acquire homes to use to meet the City’s needs for a small fraction of the cost it would have to pay to develop them itself. At a time California is spending billions to provide homeless services, it borders on farcical for the City to justify blocking the development of new homes on the grounds that it thinks the Applicants might later find themselves wanting to sell them.

For the foregoing reasons, among others, the proposed findings could not lawfully support the disapproval of this Project even if it were not protected by state housing law.

II. Disapproving the Project Would Violate State Housing Law.

As set forth *supra*, the draft resolution would not suffice as legal justification to disapprove the Project even if the Legislature had never enacted the HAA. But by enacting the HAA, the Legislature has imposed “a substantial limitation” on the government’s discretion to deny a permit.” N. Pacifica, LLC. v. City of Pacifica, 234 F. Supp. 2d 1053, 1059 (N.D. Cal. 2002), *aff’d*, 526 F.3d 478 (9th Cir. 2008) (*quotation omitted*). The City’s compliance with the HAA is judged under a standard that does not defer to localities but instead interprets the law to the fullest extent to promote the approval of housing. California Renters, 68 Cal. App. 5th at 854. And there can be no reasonable dispute that the City will violate the HAA if it proceeds to disapprove the Project.

As HCD noted in its letter:

[...] HCD has significant concerns about the City’s compliance with the Housing Accountability Act (HAA). Under Government Code section 65589.5, subdivision (j), a local government cannot disapprove or reduce the density of a housing development project that complies with applicable, objective general plan, zoning, and subdivision standards and criteria, including design review standards, in effect at the time that the

application was deemed complete unless it makes written findings supported by a preponderance of the evidence on the record that the project would have a specific, adverse impact upon the public health or safety and there is no feasible way to mitigate that impact. Disapproval means either the City/County votes on a proposed housing development project and the application is disapproved or the City/County fails to comply with the decision-making time period outlined in the Permit Streamlining Act. (Gov. Code, § 65950.)

Throughout the proceedings, up to and including Board’s vote to disapprove the Project, it has always been undisputed that the Project is a housing development project as defined in the HAA that is protected under Gov. Code §65589.5 (j). The Board voted to disapprove the Project in October with that understanding. The new findings before the Board also do not dispute this.² The HAA “deems a project consistent with applicable objective standards ‘if there is substantial evidence that would allow a reasonable person to conclude’” that the project complies. California Renters, 68 Cal.App.5th at 894 (quoting Gov. Code § 65589.5(f)(4)).

The Project complies with all objective standards not just as a matter of fact but also as a matter of law. The application was deemed complete on February 28, 2020 under the Permit Streamlining Act, and the City did not provide written documentation identifying inconsistencies with any objective standards within the mandatory 60-day deadline, and so the Project is now deemed to satisfy the standards as a matter of law. See Gov. Code § 65589.5(j)(2); *cf. Ruegg & Ellsworth*, 63 Cal. App. 5th 277, 327 (enforcing nearly identical “deemed to satisfy” requirement in Gov. Code § 65913.4); *see also* Order Granting Consolidated Petitions for Writ of Mandate, 40 Main Street Offices LLC v. City of Los Altos, No. 19-CV-349645 (Santa Clara Cty. Super. Ct. Apr. 27, 2020) (attached). It therefore cannot be disputed now that the Project is a “housing development project” that complies with objective standards.

In light of this, there is no question about whether disapproving the Project would violate the HAA. The proposed findings make no attempt to argue that the Project fails to meet any “objective” standard. The findings would disapprove the Project on the grounds it “would fail to

² The draft resolution noted that “exceptions to Planning Code requirements” available through the Conditional Use Authorization process were previously granted for rear yard and off-street loading requirements. But as HCD noted, “[t]he envelope of the proposed building remains the same size and shape as the original approved project; the amendment to the Conditional Use Authorization (CUA) is for a reallocation of interior space.” The application currently before the Board seeks no exceptions from any objective code requirements. The Project’s rear yard and off-street-loading aspects were approved in the prior CUA, and the City has already issued a site development permit to allow the development of the building with its approved yard and off-street loading components. (See 450 O’Farrell Site Permit No. 2 on file with the City and hereby incorporated by reference). Nothing in the application before the Board relates to the rear yard or off-street loading aspects of the Project, and nothing in the Board’s comments – or in the draft resolution – even remotely suggest that the Board’s disapproval has anything to do with these already-approved Project components. Regardless, even these previously approved aspects of the Project do not conflict with any of the City’s objective standards, because the city’s code specifically permits the rear yard and off-street loading components as permitted development features pursuant to the Conditional Use Authorization process. Nearly all uses and developments in the City trigger discretionary approval or review or some kind, but case law is clear that this fact does not make those uses ineligible for the HAA’s protections. *See, e.g., California Renters*, 68 Cal.App.5th at 831 (HAA applied despite the fact that development was permitted only subject to discretionary Site Plan and Architectural Review permit process).

serve the community, is not necessary and desirable for and is not compatible with the existing neighborhood and community.” These are inarguably subjective criteria which are not lawful grounds to disapprove a housing development project. *See California Renters*, 68 Cal. App. 5th at 840. The findings also do not even attempt to argue that expressing this type of opinion meets the City’s burden of proof to produce a preponderance of the evidence showing an unavoidable violation of objective public health or safety standards. Gov. Code § 65589.5(a)(3). A finding of public health or safety impacts must be a “significant, quantifiable, direct, and unavoidable impact, based on objective, identified written public health or safety standards, policies, or conditions as they existed on the date the application was deemed complete.” Gov. Code § 65589.5(j)(1)(A). A city is required to further affirmatively prove that there are no feasible means of addressing such “public health” and “safety” impacts other than rejecting or reducing the size of the Project. Gov. Code § 65589.5(j)(1)(B). Unsurprisingly, the State Legislature recently emphasized its expectation that this type of “public health or safety” condition would “arise infrequently.” Gov. Code § 65589.5(a)(3). Here, there is no evidence – much less the required preponderance of the evidence – that this Project could cause any unavoidable public health or safety impact. Nothing in the draft findings cite any “identified written public health or safety standards, policies, or conditions” related to overcrowding, traffic impacts, group housing or any other concern – to say nothing of meeting the City’s burden of proof to prove that there are no other feasible means to address those concerns without disapproving the Project.

Lest there be any doubt, the project for which the Applicants previously sought approval in the prior CUA is not financeable and cannot proceed. A vote to disapprove this Project cannot be mis-characterized as a request for the Applicants to build some other project. Denying the current application would deny a “required land use approval[] or entitlement[] necessary for the issuance of a building permit,” Gov. Code § 65589.5(h)(6)(A), and thereby disapprove the Project in violation of the HAA, and finally deny all housing opportunities for this site.

We also note that there is also nothing in the findings responsive to HCD accurately noting that the City violated the “five hearing” limit in the Housing Crisis Act and Permit Streamlining Act. Gov. Code § 65905.5(a). In total, the draft findings that the City promised would be responsive to HCD’s concerns have taken the approach of ignoring HCD’s letter entirely. This approach does not suggest that the City is merely making a good-faith error in attempting to accord with the law. To the contrary, it demonstrates that the City is proceeding with a “bad faith” disapproval of housing. *See* Gov. Code § 65589.5(k), (l); *see also* 40 Main Street Offices LLC, *supra*.

III. Conclusion

It is clear the proceeding to disapprove the Project would violate state housing law. As noted above, this letter focuses on state housing law issues, but the Applicants also reserve their rights to enforce other laws such as the Religious Land Use and Institutionalized Persons Act and fair housing laws. We note as well that unlawfully disapproving this project would subject the City not only to relief in mandamus, attorneys’ fees and fines pursuant to Gov. Code § 65589.5, but also to liability in the form of monetary damages or compensation for violation of the Applicants’ constitutional rights pursuant to, *inter alia*, 42 U.S.C. § 1983, for *inter alia*, deprivation of the Applicant’s due process-protected property rights, violation of equal

protection, inverse condemnation, and uncompensated taking of property. *See, e.g., N. Pacifica, LLC*, 234 F. Supp. 2d at 1059.

Once again, we respectfully request that the Board turn back from its current course, work to address any legitimate concerns about the Project with the Applicants, and not proceed to unlawfully disapprove this much-needed housing.

Sincerely yours,

HOLLAND & KNIGHT LLP

/s/ Daniel R. Golub

Daniel R. Golub
Partner
West Coast Land Use &
Environmental Law Practice Group

/s/ Letitia Moore

Letitia Moore
Partner
West Coast Land Use &
Environmental Law Practice Group

cc: Divya Sen, Department of Housing & Community Development
(Divya.Sen@hcd.ca.gov)
California Attorney General Rob Bonta (housing@doj.ca.gov)
State Senator Scott Wiener (senator.wiener@senate.ca.gov)
David Murray, Fifth Church of Christ, Scientist (david.murray08@gmail.com)
Ela Strong, Fifth Church of Christ, Scientist (ela@elastrong.com)
David Cincotta, Law Office of David Cincotta (davidc@dpclawoffices.com)
Robin Pick, Storzer Law (pick@storzerlaw.com)
Roman Storzer, Storzer Law (storzer@storzerlaw.com)
Sonja Trauss, YIMBY Law (sonja@yimbylaw.org)

ATTACHMENTS



Chris Elmendorf @CSElmendorf

Dec 13, 2021 · 25 tweets · [CSElmendorf/status/1470467853287522304](https://twitter.com/CSElmendorf/status/1470467853287522304)

Here are eight questions I'd like San Francisco's Bd of Supervisors to ask before tomorrow night's vote to "paper" the denials of 469 Stevenson & 450-474 O'Farrell projects (~800 homes).

Bd is skating on thin legal ice. It will fall through if there aren't good answers. 1/n

Question No. 1: "Did city provide developer of either project w/ written notice of any general plan or zoning standards the project allegedly violates, & was this notice provided w/in 60 days of date on which project application was determined or deemed complete?" 2/n

State law (HAA) says city may not deny or reduce density of project on basis of zoning / general plan standards unless city provides this timely written notice. Gov't Code 65589.5(j)(2). 3/n

(2) (A) If the local agency considers a proposed housing development project to be inconsistent, not in compliance, or not in conformity with an applicable plan, program, policy, ordinance, standard, requirement, or other similar provision as specified in this subdivision, it shall provide the applicant with written documentation identifying the provision or provisions, and an explanation of the reason or reasons it considers the housing development to be inconsistent, not in compliance, or not in conformity as follows:

(i) Within 30 days of the date that the application for the housing development project is determined to be complete, if the housing development project contains 150 or fewer housing units.

(ii) Within 60 days of the date that the application for the housing development project is determined to be complete, if the housing development project contains more than 150 units.

(B) If the local agency fails to provide the required documentation pursuant to subparagraph (A), the housing development project shall be deemed consistent, compliant, and in conformity with the applicable plan, program, policy, ordinance, standard, requirement, or other similar provision.

As best I can tell, the admin records provided to Bd for these projects don't include the HAA-required notice, or even a representation about the applications' determined-to-be-complete dates. 4/n

In fact, based on [@ONeillMoirak](#)'s data + convos w/ current & former city officials, I think SF's practice is not to make official determinations of completeness or to record dates on which applications are "deemed" complete by operation of state law. 5/n

(Which means that when SF officials deny a permit for noncompliance w/ zoning or plan standards, they're often in the dark about whether they even have authority to do so. 6/n)

Assuming Bd doesn't discover & establish timeliness of notice-of-noncompliance letters for either project, the only remaining ground on which to deny or downsize the project is that it would have a "quantifiable and unavoidable" adverse impact on ...

7/n

"public health or safety," in violation of "written, objective" standards "as they existed on the date the application was deemed complete." (That pesky unknown date, again!) Gov't Code 65589.5(j)(1). 8/n

(1) (3) When a proposed housing development project complies with applicable, objective general plan, zoning, and subdivision standards and criteria, including design review standards, in effect at the time that the application was deemed complete, but the local agency proposes to disapprove the project or to impose a condition that the project be developed at a lower density, the local agency shall base its decision regarding the proposed housing development project upon written findings supported by a preponderance of the evidence on the record that meet all of the following conditions: (A) The housing development project would have a specific, adverse impact upon the public health or safety unless the project is disapproved or approved upon the condition that the project be developed at a lower density. As used in this paragraph, a "specific, adverse impact" means a significant, quantifiable, direct, and unavoidable impact, based on objective, identified written public health or safety standards, policies, or conditions as they existed on the date the application was deemed complete. (B) There is no feasible method to satisfactorily mitigate or avoid the adverse impact identified pursuant to paragraph (1), either that the disapproval of the housing development project or the approval of the project upon the condition that it be developed at a lower density.

Such violations are not run-of-mill events; the Legislature made this much clear by declaring that they "arise infrequently." Gov't Code 65589.5(a)(3). 9/n

(3) It is the intent of the Legislature that the conditions that would have a specific, adverse impact upon the public health and safety, as described in paragraph (2) of subdivision (d) and paragraph (1) of subdivision (j), arise infrequently.

So, Question No. 2: "Why doesn't draft motion w/ findings for denial of O'Farrell project (a) cite a quantification of health / safety impact, (b) cite standard this violates, (c) show standard is objective, & (d) show standard existed on application's completeness date?" 10/n

The stuff that's in the motion now may be good for comedy or ridicule (👇), but it's beside the point under state law.

A vote to pass the O'Farrell motion is a vote to violate the Housing Accountability Act. 11/n

 **Chris Elmendorf**
@CSElmendorf

Replying to @CSElmendorf

Yes: at moment when CA is spending \$22B for homeless & low-income housing, when SF has ~8000 homeless on streets, & when SF is *buying up other microunit projects to use as shelters*, city wants to deny this one b/c of "glut" of small dwelling units. 11/n

 **YIMBY Law** @Yimby_Law
Replying to @Yimby_Law
And who bought the Panoramic?
hoodline.com/2021/10/supes-...
San Francisco.

5:28 PM · Dec 11, 2021

89 ❤️ Reply Copy link to Tweet

[Read 3 replies](#)

My remaining questions concern the Stevenson St. project. This one's trickier, since formally the motion before the Board is to adopt findings justifying reversal of certification of enviro impact report, not denial of a use permit. 12/n

The draft motion gives three reasons to justify reversal: that EIR failed to study potentially significant gentrification, historic preservation, & geotech (seismic safety) impacts.

Read on for the question to be asked about each one. 13/n

Gentrification. Bd says project may cause gentrification, which in turn may cause adverse impact on "physical env't" (the CEQA trigger). 14/n

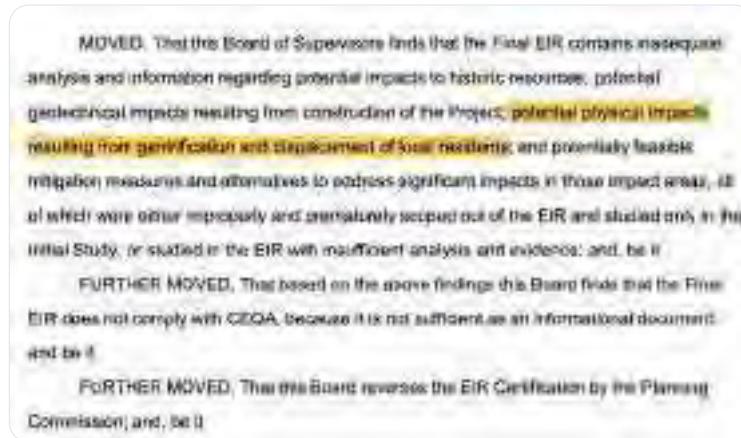

Question No. 3: "What exactly is the feared 'physical environmental impact' of gentrification, & where in the admin record is the 'substantial evidence' (a) that this project would cause gentrification, & (b) that gentrification would cause this physical impact?" 15/n

In thinking through Question No. 3, bear in mind that [u]nsubstantiated fears about potential economic effects ... are not environmental impacts that may be considered under CEQA." 16/n

<https://casetext.com/case/porterville-citizens-v-porterville>

Historic preservation. Project would replace a parking lot, which is not historic. Project does adjoin historic districts, but per McCorkle, aesthetic incongruence w/ nearby historic structures is not a CEQA impact. 17/n



Chris Elmendorf
@CSElmendorf



Replying to @CSElmendorf

First, historic resources. Project site is *parking lot* next to historic districts w/mix of uses. Per McCorkle v. City of St. Helena, aesthetic congruence w/ nearby historic buildings don't count as enviro impacts under CEQA. 16/n



5:28 PM · Dec 11, 2021



👍 46 💬 Reply 🔗 Copy link to Tweet

Read 1 reply

So, Question No. 4: "In what concrete way could this project have a significant, tangible adverse impact on nearby historic structures or districts?"

"Ugly" or "too tall" won't cut it. 18/n



Seismic & geo-tech. City until now has treated this as covered by building codes & engineering peer review, and thus outside scope of CEQA review. Supes' draft findings would make it a CEQA issue. 19/n

Question No. 5: "Why isn't requiring CEQA analysis of foundation seismic safety foreclosed by CA Supreme Court holding that impacts of env't on project aren't a CEQA issue?" (A holding made in rejecting guideline requiring seismic-safety analysis!) 20/n

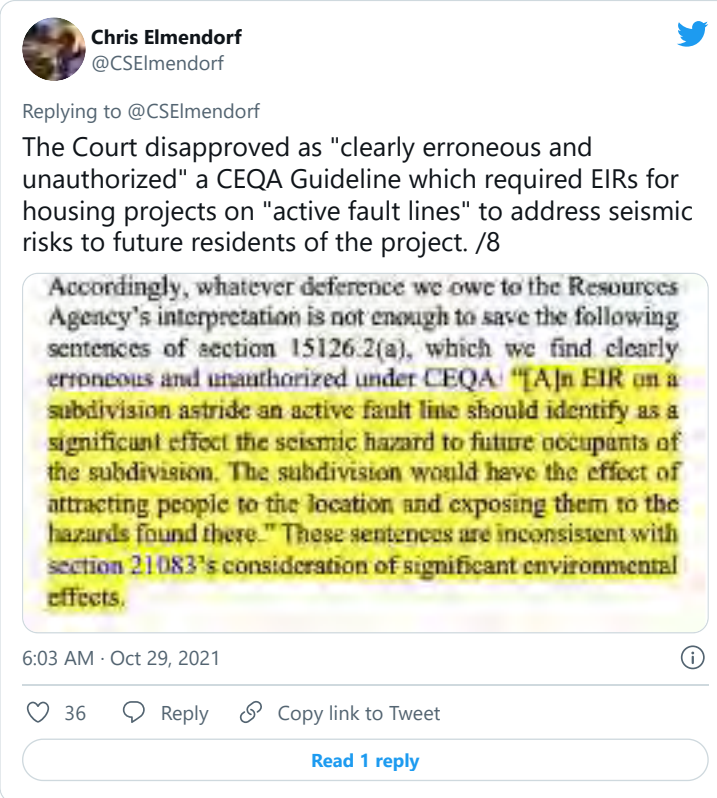

Chris Elmendorf
@CSElmendorf

Replying to @CSElmendorf

The Court disapproved as "clearly erroneous and unauthorized" a CEQA Guideline which required EIRs for housing projects on "active fault lines" to address seismic risks to future residents of the project. /8

Accordingly, whatever deference we owe to the Resources Agency's interpretation is not enough to save the following sentences of section 15126.2(a), which we find clearly erroneous and unauthorized under CEQA: "[A]n EIR on a subdivision astride an active fault line should identify as a significant effect the seismic hazard to future occupants of the subdivision. The subdivision would have the effect of attracting people to the location and exposing them to the hazards found there." These sentences are inconsistent with section 21083's consideration of significant environmental effects.

6:03 AM · Oct 29, 2021

36 Reply Copy link to Tweet

[Read 1 reply](#)

Question No. 6: "To extent you think project might 'exacerbate' seismic risks to other buildings, where in admin record is the 'substantial evidence' supporting this conjecture?" 21/n

Question No. 7: "If you were to win on your 'foundations are a CEQA issue theory,' how would you answer the former leader of SF's own CEQA team, who says it'll mean EIRs -- & NIMBY delays -- for every project that supes actually want to approve?"

22/n

 **Sarah Jones**
@sbjinsfo

I wonder how the BOS is going to feel when these findings mean that projects that they like end up needing EIRs. And I say that because this would pretty much capture any building that includes a foundation.

 **Chris Elmendorf** @CSElmendorf
Replying to @CSElmendorf

The draft resolution justifies reversal of Stevenson St. EIR on ground that the initial scoping document improperly determined that foundation safety, gentrification, & nearby historic resources were not potentially "significant" enviro impacts. 13/n

8 WHEREAS, With regards to historic resources, the Ini
9 Project would include the construction of a building that is dis
10 Register-eligible Market Street Theatre and Loft Historic Dist
11 Register eligible Sixth Street Lodging House Historic District,
12 Conservation District, and a property within the Pacific Gas &
13 Substations Discontinuous Thematic Historic District; howev
14 analysis of the impacts of the 27-story Project on adjacent hi
15 CEQA, in light of substantial record evidence of potentially si
16 analysis, the Final EIR's conclusions that the Project's setba
17 impacts on adjacent districts were premature and were inad
18 and
19 WHEREAS, In the area of geotechnical impacts, the E
20 analysis, as the Initial Study concluded that the Project wou
21 geology and soils and relied on future compliance with the C
22 Building Codes as a basis to reach its conclusion; CEQA req
23 determine whether the Project would have significant geotec
24 conclusory statements; and

1 WHEREAS, The Pro
2 area and displacement of c
3 RTC) acknowledged that th
4 environmental impacts unde
5 The Final EIR noted that "s
6 explanation, concluded that
7 displacement and gentrifica
8 environmental impacts that

2:02 AM · Dec 12, 2021

16 Reply Copy link to Tweet

[Read 1 reply](#)

Next: the draft motion says EIR failed to analyze "potentially feasible mitigation measures" w.r.t. gentrification, historic, & foundation. But since project is HAA-protected, city may not consider mitigation measures that would reduce its density.
23/n



FindLaw's California Court of Appeal case and opinions.
Case opinion for CA Court of Appeal SEQUOYAH HILLS HOMEOWNERS ASSOCIATION v. ASSOCIATES. Read the Court's full decision on FindLaw.
<https://caselaw.findlaw.com/ca-court-of-appeal/1760927.html>

Question No. 8: "Where in admin record is there substantial evidence that project could be feasibly 'mitigated' in some way that would reduce gentrification or historic impacts w/o reducing density." 24/n

Finally: Appellant says real reason for appeal is to reduce project size & make developer donate 1/3 of lot. The HAA prevents this "condition of approval" & harshly penalizes bad faith. @California_HCD has warned you that CEQA reversal may violate HAA.

Watch out!

25/end



...



Chris Elmendorf @CSElmendorf

Dec 11, 2021 · 24 tweets · [CSElmendorf/status/1469720638411526147](https://twitter.com/CSElmendorf/status/1469720638411526147)

San Francisco has posted its doozy of a draft response to warning letter from [@GavinNewsom](https://twitter.com/GavinNewsom)'s new housing accountability team.

(Is city's mission to bridge the partisan divide by proving itself a laughingstock to [@nytimes](https://www.nytimes.com/) & Fox News alike?)

1/n

<https://sfgov.legistar.com/View.ashx?M=A&ID=914226&GUID=3E6E4960-F5DA-44E1-B425-3B9EC23A44AC>

Context: state called out Board of Supes for voting down two large infill housing projects (800+ homes), in apparent violation of state's Housing Accountability Act.

2/n



State then asked city to provide "written findings" explaining city's "reasoning and evidence," in light of state law. 3/n

Chris Elmendorf @CSElmendorf

Look at @California_HCD's Housing Accountability Unit, starting strong!
So much to like in the letter they just sent to San Francisco about the apparent CEQA-launched denial of 469 Stevenson St. project. 1/14

Senator Scott Wiener @Scott_Wiener

Today the State, via @California_HCD, informed SF that the Board of Supervisors may have violated state housing law by rejecting recent projects (eg Stevenson St) & that SF may be violating state law with an overly extensive housing permit process.

Harsh yet entirely appropriate

3:32 PM · Nov 23, 2021

[Read the full conversation on Twitter](#)

89 Likes · 1 Reply

For this reason, HCD requests that the City Council provide the written findings to HCD and the public. HCD will also provide a copy of the findings to the public. HCD will also provide a copy of the findings to the public. HCD will also provide a copy of the findings to the public.

Housing Accountability Act

For the same reasons, HCD has also requested that the City Council provide the written findings to HCD and the public. HCD will also provide a copy of the findings to the public. HCD will also provide a copy of the findings to the public. HCD will also provide a copy of the findings to the public.

The city's response is a pair of draft resolutions, which supes will vote on next Tuesday. The resolutions affirm the supes' previous votes w/o even acknowledging the HAA or the state's letter. 4/n

Regarding the O'Farrell St. project, the resolution justifies denial on ground that units would be small, w/minimal kitchens--& thus not in interest of "the neighborhood." But HAA allows denial of zoning-compliant projects only on basis *objective*... 5/n

WHEREAS, The Tenderloin neighborhood has a high concentration of low-income families and insufficient housing to serve these families, and is a food desert; and

WHEREAS, The Planning Department's 2017 report titled Housing for Families with Children, on file with the Clerk of the Board of Supervisors in File No. 210858 and incorporated herein by reference, states that unit size and affordability are significant housing stock issues impacting families; that families need more affordable options and larger units to accommodate children and multiple generations of family members, as well as amenities such as open space, storage space, and on-site childcare; and that there is a mismatch between small units and residents who occupy them, and overcrowding in many units in San Francisco, a majority of which overcrowded units are occupied by families; and

WHEREAS, Appellant provided testimony that there is significant overcrowding of families in small units in the Tenderloin neighborhood; and

WHEREAS, The Project would fail to meet the needs of the neighborhood, including the needs of families, due to the small size and lack of full kitchen facilities in the Project's group housing rooms, given that families require space for children and multigenerational

health or safety standards, and city resolution identifies no such standard requiring larger units or fuller kitchens.

And let's not lose sight of big picture... 6/n

Chris Elmendorf @CSElmendorf

Major decision from Court of Appeal interpreting California's Housing Accountability Act. Read [@carla_org](#)'s thread below for highlights, or continue with this one if you want the legal nitty gritty. /1

CaRLA @carla_org

Last Friday, we scored a major victory for housing by winning our appeal in CaRLA v. San Mateo. This victory leaves no doubt as to the power and effectiveness of the Housing Accountability Act, and solidifies the legitimacy of statewide limits on local control of housing. twitter.com/carla_org/stat...

1:38 AM · Sep 14, 2021

[Read the full conversation on Twitter](#)

57 ❤️ Reply Copy link to Tweet

[Read 1 reply](#)

As cities across California are licensing tent encampments, providing sheds as shelters, & wracking all available brains to find tolerable housing options between tent-on-sidewalk and a \$750k "affordable" unit, SF is... 7/n

denying this microunit project b/c "families are overcrowded."

Might it be that families are overcrowded b/c they're outbid for family-sized homes by groups of young tech workers who share a lease? Workers who'd happily rent a berth in an O'Farrell St "tech dorm"? 8/n

WHEREAS, the Project units' lack of kitchens and food storage areas, area residents' limited access to groceries in the neighborhood, safety concerns voiced by members of the public at the September 28, 2021 public hearing, and the likely relatively high income of tenants who can afford the rents that the Project sponsor testified it expects to charge for units in the Project, residents of the Project would likely rely heavily on food delivery services, creating more congestion from food delivery vehicles (e.g., GrubHub, Door Dash deliveries), leading to more pedestrian/vehicle collisions and increased pollution from such vehicles; the San Francisco County Transportation Authority's TNC & Congestion report, on file with the Clerk of the Board of Supervisors in File No. 210858 and incorporated herein by reference, supports this conclusion, demonstrating that the Tenderloin neighborhood already has significant congestion caused by Transportation Network Company (TNC) services; and

WHEREAS, the Project units' lack of kitchens and food storage areas, area residents' limited access to groceries in the neighborhood, safety concerns voiced by members of the public at the September 28, 2021 public hearing, and the likely relatively high income of tenants who can afford the rents that the Project sponsor testified it expects to charge for units in the Project, residents of the Project would likely rely heavily on food delivery services, creating more congestion from food delivery vehicles (e.g., GrubHub, Door Dash deliveries), leading to more pedestrian/vehicle collisions and increased pollution from such vehicles; the San Francisco County Transportation Authority's TNC & Congestion report, on file with the Clerk of the Board of Supervisors in File No. 210858 and incorporated herein by reference, supports this conclusion, demonstrating that the Tenderloin neighborhood already has significant congestion caused by Transportation Network Company (TNC) services; and

Alternative grounds for denial: city says residents of this car-free project might use Uber when they're not walking or taking transit, causing congestion, pollution, and "increased pedestrian/vehicle collisions." 9/n

WHEREAS, the Project units' lack of kitchens and food storage areas, area residents' limited access to groceries in the neighborhood, safety concerns voiced by members of the public at the September 28, 2021 public hearing, and the likely relatively high income of tenants who can afford the rents that the Project sponsor testified it expects to charge for units in the Project, residents of the Project would likely rely heavily on food delivery services, creating more congestion from food delivery vehicles (e.g., GrubHub, Door Dash deliveries), leading to more pedestrian/vehicle collisions and increased pollution from such vehicles; the San Francisco County Transportation Authority's TNC & Congestion report, on file with the Clerk of the Board of Supervisors in File No. 210858 and incorporated herein by reference, supports this conclusion, demonstrating that the Tenderloin neighborhood already has significant congestion caused by Transportation Network Company (TNC) services; and

Oh, and best of all, city says there is a "glut" of small housing units in the Tenderloin and along Market Street.

10/n

WHEREAS, Applicants have provided evidence of a glut of entire small units without full kitchens in the Tenderloin and Market areas; the Panoramic development at 1321 Mission Street is an example of this glut, the Panoramic, which consists of efficiency units that do not have full kitchens, and that lack stoves, full-size refrigerators and adequate food storage and preparation space, has high vacancy rates and has been unsuccessful, and is being marketed for sale; and

Yes: at moment when CA is spending \$22B for homeless & low-income housing, when SF has ~8000 homeless on streets, & when SF is *buying up other microunit projects to use as shelters*, city wants to deny this one b/c of "glut" of small dwelling units. 11/n



YIMBY Law
@Yimby_Law



Replying to @Yimby_Law

And who bought the Panoramic?

hoodline.com/2021/10/supes-...

San Francisco.



Supes approve Panoramic Apartments for homeless housing, despite co...
In a quick rubber-stamp vote with no discussion, the supervisors approved the \$87 million purchase of the Panoramic, adding 160 units o...
hoodline.com

7:23 PM · Dec 10, 2021



♥ 45 💬 Reply 🔗 Copy link to Tweet

[Read 2 replies](#)

What about the other project, 469 Stevenson? Here SF is doing its damndest to provide every other city in the state w/ a roadmap for using enviro review (CEQA) to kill housing projects that state law (HAA) protects. 12/n



How an outdated environmental law is sabotaging California's new ho...

San Francisco's infamous 469 Stevenson project was a case study in California legal...

<https://www.sfchronicle.com/opinion/openforum/article/How-an-outdated-environmenta...>

The draft resolution justifies reversal of Stevenson St. EIR on ground that the initial scoping document improperly determined that foundation safety, gentrification, & nearby historic resources were not potentially "significant" enviro impacts. 13/n

8 WHEREAS, With regards to historic resources, the Initial Study acknowledged that the
9 Project would include the construction of a building that is directly adjacent to the National
10 Register-eligible Market Street Theatre and Loft Historic District, National and California-
11 Register eligible Sixth Street Lodging House Historic District, and the Mint-Mission article 11
12 Conservation District, and a property within the Pacific Gas and Electric (PG&E) City Beautiful
13 Substations Discontinuous Thematic Historic District; however, the EIR included no further
14 analysis of the impacts of the 27-story Project on adjacent historic districts as required by
15 CEQA, in light of substantial record evidence of potentially significant impacts; absent that
16 analysis, the Final EIR's conclusions that the Project's setbacks would avoid significant
17 impacts on adjacent districts were premature and were inadequately supported by evidence;
18 and
19 WHEREAS, In the area of geotechnical impacts, the EIR did not conduct adequate
20 analysis, as the Initial Study concluded that the Project would not result in any impacts to
21 geology and soils and relied on future compliance with the California and San Francisco
22 Building Codes as a basis to reach its conclusion; CEQA requires that the EIR analyze and
23 determine whether the Project would have significant geotechnical impacts, beyond those
24 conclusory statements; and

1 WHEREAS, The Project's physical effects relating to gentrification of the surrounding
2 area and displacement of current residents were not studied in the EIR; the Final EIR (in the
3 RTC) acknowledged that these socio-economic effects, in themselves, are not considered
4 environmental impacts under CEQA, absent a related physical change in the environment.
5 The Final EIR noted that "some displacement may occur," but without benefit of study or
6 explanation, concluded that "the proposed project is not likely to result in residential
7 displacement and gentrification" and therefore improperly dismissed any potential physical
8 environmental impacts that may result from gentrification or displacement; and

As [@TDuncheon](#) & I explain in a series of [@SlogLawBlog](#) posts and now a law review paper, this raises a host of thorny legal questions, including bad faith, enforceability of CEQA deadlines (SF decision is overdue), & CEQA baselines / causation. 14/n

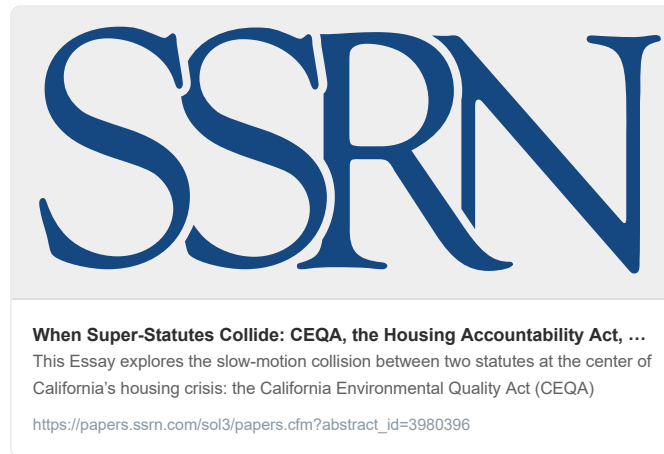

Even if one (wrongly) accepts a conventional CEQA baseline for gauging impact of an HAA-protected project, the supes are pushing a radical expansion of CEQA, against statutory text & precedent. 15/n

First, historic resources. Project site is *parking lot* next to historic districts w/mix of uses. Per McCorkle v. City of St. Helena, aesthetic congruence w/ nearby historic buildings don't count as enviro impacts under CEQA. 16/n



As the McCorkle court said (presaging the 469 Stevenson debacle): "To rule otherwise would mean that an EIR would be required for every urban building project ... if enough people could be marshaled to complain about how it will look."

17/n



Second, gentrification. "Unsubstantiated fears about potential economic effects resulting from a proposed project are not environmental impacts that may be considered under CEQA." So said Court of Appeal in Porterville Citizens v. Porterville (2007). 18/n

<https://casetext.com/case/porterville-citizens-v-porterville>

CEQA is concerned w/ "physical environment," not social impacts. Supes' resolution asserts that gentrification may impact phys. env't, but it doesn't (1) specify any such physical impact, or (2) provide evidence beyond "unsubstantiated fears." 19/n

https://leginfo.ca.gov/faces/codes_displaySection.xhtml?lawCode=PRC§ionNum=21060.5#:~:text=21060.5,of%20historic%20or%20aesthetic%20significance.

Lastly, we have supes' demand for analysis of alternative foundations, which EIR excluded on ground that foundation safety is covered by building code. This runs against CA Supreme Court holding that seismic risk to project isn't a CEQA impact. 20/n



 **Chris Elmendorf**
@CSElmendorf 

Replying to @CSElmendorf

The Court disapproved as "clearly erroneous and unauthorized" a CEQA Guideline which required EIRs for housing projects on "active fault lines" to address seismic risks to future residents of the project. /8



Accordingly, whatever deference we owe to the Resources Agency's interpretation is not enough to save the following sentences of section 15126.2(a), which we find clearly erroneous and unauthorized under CEQA: "[A]n EIR on a subdivision astride an active fault line should identify as a significant effect the seismic hazard to future occupants of the subdivision. The subdivision would have the effect of attracting people to the location and exposing them to the hazards found there." These sentences are inconsistent with section 21083's consideration of significant environmental effects.

6:03 AM · Oct 29, 2021 

 36  Reply  Copy link to Tweet

[Read 1 reply](#)

It also upends CEQA's presumption that "building code issues" are ministerial and thus outside scope of CEQA review. 21/n

 **Chris Elmendorf** @CSElmendorf 

Hey all you CEQA lawyers out there: Is long-game of Eberling's seismic-safety argument an effort to blow up CEQA-Guidelines presumption that building permits are ministerial and thus exempt from CEQA review? /1



15263(b)(2)(B) Ministerial projects are exempt from the requirements of CEQA. The determination of what is "ministerial" can most appropriately be made by the particular public agency involved based upon its analysis of its own laws and such public agency should make such determination either as a part of its implementing regulations or as a case-by-case basis.

15263(b)(2)(B) Is the design of any discretionary provision contained in the local ordinance or other law establishing the requirements for the project, license, or other ministerial permit, the following actions shall be presumed to be ministerial:

- (1) Issuance of building permits;
- (2) Issuance of building licenses;
- (3) Approval of final public utilities;
- (4) Approval of final utility service connections and disconnections;

15263(b)(2)(B) Each public agency should, in its implementing regulations or ordinance, provide an identification or list of such of its projects and actions which are deemed ministerial under the applicable local ordinance.

15263(b)(2)(B) Where a project involves an approval that contains elements of both a ministerial action and a discretionary action, the project shall be deemed to be discretionary and will be subject to the requirements of CEQA.



State Attorney General, Section 11800, Public Resources Code; California, Section 11800000, Public Resources Code; City of Berkeley, 11 Cal. App. 3d 1117

 **Chris Elmendorf** @CSElmendorf

The mastermind behind the SF supes' CEQA-laundered denial of a 500-home infill project at 469 Stevenson St. finally weighs in. And puts the city in an even deeper legal hole. 1/14
48hills.org/2021/12/the-fa...

6:41 AM · Dec 9, 2021 

 [Read the full conversation on Twitter](#)

 8  Reply  Copy link to Tweet

[Read 1 reply](#)

And, if sustained, it might well crush the business model of development in San Francisco, where one set of firms specialize in entitlement and another in construction. 22/n

SF's insane entitlement process (way worse than any other city studied by [@ONeillMoirak](#)) would become even costlier under supes' logic, since all engineering work would have to be done before proponent learns whether city will even accept project's size & appearance. 23/n

This a moment of truth for [@GavinNewsom](#) [@GVelasquez72](#) [@AGRobBonta](#) [@CaHousingGuy](#) & [@ShannanWestCA](#): Are you serious about housing accountability, or are denials just fine if topped w/cherry of progressive rhetoric?
24/end

[@ezraklein](#) [@JerusalemDemsas](#)



Opinion | California Is Making Liberals Squirm

If progressivism can't work there, why should the country believe it can work anywhere else?

<https://www.nytimes.com/2021/02/11/opinion/california-san-francisco-schools.html>

• • •

Christopher S. Elmendorf & Tim Duncheon Nov 28 5 min read

A Seismic Shift in Land Use Law?

Late last month, observers erupted in fury when San Francisco's Board of Supervisors voted down a proposal to build nearly 500 new homes -- many affordable -- on a downtown site now being used for valet parking. The Board's vote came short on the heels of a major Court of Appeal decision upholding the state's Housing Accountability Act (HAA), which the Legislature has greatly strengthened in recent years. The HAA usually requires cities to approve housing projects that a reasonable person *could* deem compliant with applicable standards, even if other reasonable people might disagree.

San Francisco evaded the HAA by using a different law, the California Environmental Quality Act (CEQA), to put the downtown project on ice. Oakland and Sonoma have also used the same maneuver, albeit to much less fanfare. This presages an epic legal clash, which we shall explore in a four-post series for SLoG and a forthcoming law review essay. This post is the appetizer.

The HAA and the CEQA both have fair claims to being what legal scholars Bill Eskridge and John Ferejohn call "super-statutes." As Eskridge and Ferejohn define it, a super-statute is a law that:

(1) seeks to establish a new normative or institutional framework for state policy and (2) over time does "stick" in the public culture such that (3) the super-statute and its institutional or normative principles have a broad effect on the law—including an effect beyond the four corners of the statute.

As we'll explain in our next post, CEQA became super in the 1970s, thanks to a run of California Supreme Court decisions that construed it broadly so as to give, as the Court saw it, "the fullest possible protection" to the environment. The HAA began earning its stripes much more recently. The turning point came in 2017, when the Legislature dramatically strengthened the law and codified that it "be interpreted and implemented in a manner to afford the fullest possible weight to the interest of, and the approval and provision of, housing."

The ostensible super-ness of the two statutes creates a predicament for courts and other actors, because CEQA and the HAA could not be more different in their basic institutional and normative principles. Consider this:

- CEQA's working premise is that "new construction" is bad for the environment. "Current environmental conditions" in the vicinity of a proposed project should be preserved if at all possible. By contrast, the HAA regards the construction of housing in urbanized areas as presumptively good for the environment. It opens with a legislative finding that local barriers to housing development cause "urban sprawl, excessive commuting, and air quality deterioration," "undermining the state's environmental and climate objectives."

- CEQA privileges slow, careful, deliberative evaluation of every possible environmental impact. If there is a “fair argument” that a project “may” have any significant local environmental impact, CEQA compels the preparation of an exhaustive environmental impact report (EIR). The HAA calls for speed. It requires cities to notify developers of any general plan or zoning standards a project violates soon after the project is submitted, and it stipulates that violations of the state’s Permit Streamlining Act shall be deemed violations of the HAA.
- Courts in CEQA cases presume that cities act in good faith (unless the city shortcuts environmental review). When pertinent facts and empirical inferences are disputed, courts give deference to the city’s judgment. The HAA distrusts cities. It eliminates the traditional deference that courts gave to cities regarding a housing project’s compliance with local standards; it prevents cities from using discretionary standards to deny or reduce the density of a project; and it authorizes courts to order the approval of projects that were denied in bad faith.

So how will the HAA and CEQA fit together? On one view, CEQA must reign supreme, because a longstanding provision of the HAA states, “Nothing in this section shall be construed to relieve the local agency from complying with ... the California Environmental Quality Act.”

But, as noted, the Legislature more recently proclaimed that the HAA “shall be interpreted and implemented in a manner to afford the fullest possible weight to the interest of, and the approval and provision of, housing.” Later posts in this series will argue that to achieve its stated purpose – to “meaningfully and effectively curb[] the capability of local governments to deny, reduce the density for, or render infeasible housing development projects” – the HAA must exert gravitational pull on CEQA. The alternative is a world in which cities would have virtually unfettered discretion to use CEQA to delay projects indefinitely, to force project proponents to pay for round after round of expensive environmental studies, and to encumber projects with costly “mitigation” requirements even if the project would be a big environmental win.

* * *

Our next piece in this series will recount the evolution of CEQA and the HAA, illustrating their respective claims to super-statute status. We will see that CEQA’s super-ness was revealed in part by its crushing of a pro-development precursor to the HAA, the Permit Streamlining Act.

Our third post will delve into the problem one of us has dubbed “CEQA-laundered project denial,” now exemplified by 469 Stevenson St. in San Francisco. The municipal strategy of using CEQA to evade the HAA exploits soft spots in CEQA and background principles of administrative law. We’ll argue, however, that the “super” HAA can provide a remedy, either directly or through its gravitational pull on CEQA and administrative law.

Our final piece will argue that the HAA ought to shape environmental impact analysis itself. Because CEQA only applies to discretionary governmental acts, environmental review for HAA-protected housing projects should consider only impacts caused by discretionary conditions of approval imposed by the city, not all of the impacts that result from adding new dwelling units to the site. This only makes sense: the latter are caused by state law (the HAA), not municipal discretion. Our HAA-informed gloss on the scope of CEQA review would eliminate substantial environmental reviews for the mine run of zoning-compliant housing projects.

Our scope-of-review proposal is consistent with CEQA's first principles, but it would require jettisoning or substantially circumscribing several judicial precedents which have been incorporated into the official CEQA Guidelines. It's up to the Governor and his appointees at the Office of Planning and Research and the Natural Resources Agency to decide whether to revise the Guidelines. If they do, and if the Legislature acquiesces, then the HAA will truly merit the moniker, "superstatute." It will have "stuck in the public culture" and exerted "a broad effect on the law."

But that is only one possible future. Another is that CEQA swallows the HAA, expelling more fodder for critics who've lampooned California's symbolically liberal but operationally conservative politics. Stay tuned.

The authors write in their personal capacity. Nothing in these posts represent a position of the University of California or the U.S. District Court for the Northern District of California.

Christopher S. Elmendorf & Tim Duncheon Nov 30 9 min read

How CEQA and the HAA Became “Super”

In [yesterday's post](#), we asserted that the recent denial of a downtown housing project in San Francisco portends a generational clash of super-statutes, with the California Environmental Quality Act (CEQA) facing off against the state's Housing Accountability Act (HAA). In subsequent posts, we will explore the particulars of the CEQA-HAA conflict, as illustrated by the saga of the San Francisco project. Today, however, our goal is simply to show that CEQA and the HAA both have plausible claims to being super-statutes, which is what makes the clash between them so arresting.

Recall [Eskridge and Ferejohn's](#) definition. A super-statute is a law that:

(1) seeks to establish a new normative or institutional framework for state policy and (2) over time does “stick” in the public culture such that (3) the super-statute and its institutional or normative principles have a broad effect on the law—including an effect beyond the four corners of the statute.

The first half of today's post explains how CEQA became a superstatute in the 1970s, and muscled a precursor of the HAA into near-oblivion. The second half takes up the HAA and shows how it's becoming “super” today.

The California Environmental Quality Act

Enacted in 1970, a year after Congress passed the National Environmental Policy Act, CEQA heralded a transition from Governor Pat Brown's California -- a land of burgeoning highways, dams, and suburbs -- to the slow-growth California that his son, Jerry, would preside over. Whether the Legislature intended CEQA to be a super-statute is open to debate, but, looking back, it's clear that CEQA did “establish[] a new normative [and] institutional framework for state policy,” and that the framework “stuck in the public culture” and had “a broad effect on the law.”

Two early judicial decisions launched CEQA on its path to super-ness. In *Friends of Mammoth v. Bd. of Supervisors*, the California Supreme Court gave a “broad interpretation to the act's operative language” and extended CEQA to cover private activities (such as homebuilding) that require public permits. Next came *No Oil, Inc. v. City of Los Angeles*, which held that CEQA requires preparation of a full environmental impact report “whenever it *can be fairly argued* ... that the project *may* have a significant environmental impact,” not just where the project is likely to have “important” or “momentous” impacts.

Beyond their immediate holdings, *Friends of Mammoth* and *No Oil* stood for a larger principle: that CEQA should be construed broadly and purposefully to give “the fullest possible protection” to the environment. Although the Legislature has often tinkered with CEQA, it hasn't challenged this foundational maxim, which courts continue to invoke to this day.

CEQA has certainly had a “broad effect on the law--including an effect beyond the four corners of the statute.” The best example is the courts' reliance on CEQA to disembowel the Permit Streamlining Act of 1977 (PSA), which was something of a precursor to the Housing Accountability Act.

The PSA originally required cities to approve or deny applications for a “development project” within one year of receiving a complete application, on pain of the project being “deemed approved” as a matter of law. The Act did not expressly state that an agency's failure to complete environmental review within the one-year period would

result in the project's constructive approval, but everything about the statute suggests that this was the Legislature's intention.

Yet when courts confronted the question of whether a development project could be deemed approved by operation of the PSA notwithstanding the agency's failure to complete and certify an environmental impact report, they answered with a perfunctory no. Automatic approval in such circumstances would be an unthinkable "drastic" result, the Court of Appeal said, and because the Legislature "did not mention EIR certification in the [PSA's] automatic approval provisions," the court refused to countenance it. The gravitational pull of the superstatute, CEQA, overwhelmed what should have been a fairly easy inference from the text and structure of the PSA.

In a later case, the Court of Appeal held that CEQA's time limits could be enforced by mandamus -- if a city sits for years on a completed environmental impact report without taking official action to certify or disapprove it. But this gesture at the enforceability of the one-year deadline for completing EIRs was gravely undermined by another Court of Appeal decision, *Schellinger Bros. v. City of Sebastopol*. *Schellinger* held that courts may not order a city to certify an environmental impact report (as opposed to ordering the city to make up its mind about whether to certify it). Even more damningly, *Schellinger* held that the project applicant had, by cooperating with the city well past the one-year deadline, forfeited its right to enforce CEQA's deadlines.

Nowhere did *Schelleinger* acknowledge that developers have an obvious economic incentive to cooperate with cities that exercise discretionary authority over their projects. That the court's decision had the practical effect of nullifying the PSA for any project that requires an environmental impact report also went unmentioned. The pull of the superstatute had sucked the guts out of the PSA.

The Housing Accountability Act

The HAA was far from super as enacted in 1982. It originally consisted of just two short paragraphs telling local governments to approve zoning-compliant housing projects unless the project would injure public health or safety. A 1990 amendment added additional protections for affordable projects (today defined as 20% low-income or 100% moderate income). Among other things, the amendment stipulated that a city may rely on its general plan or zoning to deny an affordable project only if the city has adopted a state-approved "housing element" to accommodate regionally needed housing.

Subsequent tweaks to the HAA (1) disallowed local governments from denying zoning-compliant projects except on the basis of written health or safety standards; (2) defined projects as zoning-compliant if they satisfy the objective standards found in the city's zoning code and general plan as of the date of the developer's project application; (3) cracked down on certain obvious ruses, such as cities defining zoning-code violations as a health-and-safety violation; (4) required cities that wrongfully deny an affordable project to pay the prevailing party's legal fees; (5) authorized courts to compel cities to take action on a wrongfully denied project within 60 days; and (6) authorized courts to fine cities that deny projects in bad faith and continue dilly-dallying after the court's order.

All of this sounds pretty super, but if the test for a superstatute is that it "sticks" in "the public culture" and "has a broad effect on the law," then the HAA did not become a serious superstatute candidate until 2016-2017. There had been very few reported cases under the statute, most likely because developers who hope to do business with a city in the future are generally reluctant to sue it. In 2015, however, a ragtag bunch of self-described "Yimbys" coalesced in San Francisco, discovered the HAA, and started suing suburbs for denying regionally needed housing. It wasn't entirely clear whether they even had standing, but the Legislature answered their call and authorized HAA enforcement by "housing organizations."

A year later, in 2017, the Legislature enacted a pair of bills that dramatically strengthened the HAA and declared it to be super. Assembly Bill 1515 took up the question of what it means for a housing project to comply with general plan, zoning, and design standards. The courts had long given deference to cities on such matters, refusing to set aside municipal determinations that a project is noncompliant if any reasonable person could agree with the city's conclusion. AB 1515 turned that doctrine on its head, defining projects as compliant as a matter of law if any reasonable person could deem the project to comply on the record before the city – notwithstanding reasonable or even strong arguments going the other way.

A companion bill, SB 167, required cities to give prompt written notice to developers of any zoning, general plan, or design standard that the proposed project violates, on pain of the project being deemed to comply as a matter of law. SB 167 also narrowed the HAA's carveout for health and safety standards, requiring cities to show by a preponderance of the evidence that the health or safety standard in question would in fact be violated by the project. Finally, SB 167 codified numerous Legislative findings, include this:

The Legislature's intent in enacting [the HAA] in 1982 and in expanding its provisions since then was to significantly increase the approval and construction of new housing ... by meaningfully and effectively curbing the capability of local governments to deny, reduce the density for, or render infeasible housing development projects.... That intent has not been fulfilled.

And this:

It is the policy of the state that this section be interpreted and implemented in a manner to afford the fullest possible weight to the interest of, and the approval and provision of, housing.

A year later, the Legislature added this:

It is the intent of the Legislature that the conditions that would have a specific, adverse impact upon the public health and safety [within the meaning of the HAA] arise infrequently.

In 2019, the Legislature codified a preliminary application process, allowing developers to quickly establish the date on which the zoning, general plan, and health and safety standards applicable to their project would be locked. The Legislature also spelled out what it means for a standard to qualify as objective, such that it may be used to deny or reduce the density of a housing project.

All of this certainly evinces a legislative intent to forge a superstatute, but whether the HAA "'stick[s]' in the public culture such that ... its institutional or normative principles have a broad effect on the law" ultimately depends on how other actors respond to it. Will the courts, the executive branch, and local governments also treat the HAA as super?

In September of 2021, the pumped-up HAA passed its first judicial test with flying colors. The City of San Mateo had denied a small condo project on the basis of the city's Multi-Family Design Guidelines, which prescribe "a transition or step in height" between new multifamily buildings and adjoining single-family homes. When a nonprofit housing organization challenged the project denial in court, San Mateo argued that the HAA violated its right to "home rule" under California's constitution and the prohibition against delegation of municipal authority. In the alternative, the city asserted that the HAA's definition of project compliance left intact the tradition of judicial deference to cities on

questions about the meaning of local ordinances, and that the city in denying the project had plausibly "interpreted" its Design Guidelines to require setbacks the project lacked. A trial court accepted the city's home-rule and statutory arguments, but the Court of Appeal would have none of it.

Before the appellate court, San Mateo and local government *amici* mustered new constitutional attacks on the HAA -- not just home rule and private delegation, but due process too. It would have been easy for the Court of Appeal to dodge the new issues, but the court reached out and decided all the constitutional questions -- against the city -- thereby securing the HAA's footing going forward. The appellate court also carefully traced the evolution of the HAA, juxtaposing it against the seeming intractability of California's housing shortage. It concluded, "The HAA is today strong medicine precisely because the Legislature has diagnosed a sick patient."

The Legislature's instruction that the HAA "be interpreted and implemented in a manner to afford the fullest possible weight to ... housing" was reiterated three times in the court's opinion.

As for San Mateo's design guidelines, the Court of Appeal held that they were not objective, and, in the alternative, that a reasonable person could deem the project at issue to comply with them. Hard-eyed independent judicial review, not deference, was the order of the day. "It [would be] inappropriate to defer to the City's interpretation of the Guidelines," the court explained, lest the City "circumvent[] what was intended to be a strict limitation on its authority."

CaRLA v. City of San Mateo is only one case, of course, but other actors in California's legal-political establishment are also embracing the HAA and signaling that they want it to have "a broad effect on the law." After the trial court in *CaRLA v. San Mateo* struck down the HAA, Attorney General Becerra announced that his office would intervene on appeal. When the Court of Appeal's decision came down, new AG Bonta put out a press release trumpeting the big win.

Last summer, the Governor requested and the Legislature authorized funding for a new Housing Accountability Unit within the Department of Housing and Community Development. Fully staffed, the HAU will be a 25-person team that investigates alleged violations of state housing law, sends warning letters to cities, and makes referrals to the AG's new "housing strike force." The HAA is not the only housing law the HAU and the strike force will enforce, but it is the capstone, and the fact that these new enforcement capabilities came together in the shadow of *CaRLA v. City of San Mateo* suggests that the HAA is in fact bringing about "a new normative [and] institutional framework for state policy," one which will "stick[] in the public culture" and have "a broad effect on the law."

The acid test is now at hand. A day after San Francisco's Board of Supervisors stalled the 469 Stevenson St. project -- voting to require further environmental study while treating the vote as a project denial -- the director of the state housing department announced that the Housing Accountability Unit had launched an investigation. Is the HAA super enough to stand up to CEQA? Or will it tumble like its precursor, the Permit Streamlining Act? That is the subject of our next post.

Christopher S. Elmendorf & Tim Duncheon Dec 1 16 min read

Does the HAA (or anything else) Provide a Remedy CEQA-Laundered Project Denials?

Here is Part 3 of this four-part series:

The HAA prevents cities from denying or reducing the density of housing projects, but it doesn't exempt projects from environmental review under CEQA. CEQA spells out time limits for the completion of environmental reviews, but as [yesterday's post](#) explained, those limits have proven illusory in court. So if a city wants to deny a project that the HAA protects, what's to keep the city from laundering the denial, as it were, through CEQA? Can the city keep asking the developer for additional environmental studies until, after squandering years and fortunes, the developer cries uncle and walks away?

That's the million-dollar question raised by our running example, the San Francisco Board of Supervisors' recent [8:3 vote sustaining a local gadfly's appeal](#) of the 469 Stevenson St. project. Rather than deny the project outright or reduce its density (likely HAA violations), the Board [reversed the planning commission's certification](#) of the project's Environmental Impact Report and directed the clerk to prepare findings that the EIR was inadequate.

Yet in view of what the Supervisors said at the hearing and afterwards, it's pretty clear that the Board's real objective was not to air out and mitigate specific environmental impacts but to nix the project. Most of the Supervisors who voted "No" argued that the project was not affordable enough and would cause gentrification – which is [not an environmental impact](#) and which is [exceedingly unlikely](#) to be caused by the project in any event. Supervisor Mandelman [told a reporter](#) that he'd "feel very good about this vote" if the site "become[s] a 100% affordable project," but that if "15 years from now it's still a parking lot, then I will not feel good." That's an explanation for a vote to deny, not a vote for further environmental study. Supervisor Melgar said the problem was that the developer hadn't ["negotiated a deal" with TODCO](#), a politically powerful nonprofit. That of course has no bearing on the adequacy of the EIR.

The supervisors who voted "No" also knotted themselves up with self-contradictory objections. For example, [Ronen](#) and [Mandelman](#) stressed that the developer didn't have financing and that the project probably wasn't economically viable (the implication being: "don't blame us for blocking housing"), yet they also demanded that the developer reserve more units for low-income households – which would make the project even *more* difficult to finance.

The supervisor who came closest to voicing an environmental objection was Supervisor Ronen, who expressed concern that the project's [foundation might be inadequate](#). She pointed to another downtown project, the Millennium Tower, that had required an expensive retrofit, and she argued that the EIR for Stevenson St. should have fleshed out the seismic issues in detail. (The Initial Study treated these issues as "insignificant" because they're addressed by the building code and an engineering peer-review required of all large buildings. Accordingly, the EIR did not further address them.) However, no one put any evidence in the record suggesting that a code-compliant, peer-reviewed project on the site would be an earthquake hazard to people or buildings nearby. Nor, as

best we can tell, had Ronen or any other supervisor objected to previous EIRs that treated seismic impacts as adequately addressed through the building code and engineering peer review. In any case, contrary to Ronen's claims to the press, the impact of an earthquake on the proposed building is not an "environmental impact" under CEQA.

All of this suggests that that the seismic safety issue – the only plausibly legitimate justification for the Board's decision to reverse the CEQA certification – was pretextual. It was a fig leaf to cover up what the Board intended but was not allowed by law to do: to disapprove the project because it's too big or not affordable enough.

Capitalizing on Administrative Law's Achilles Heel

The strategy of laundering project denials through CEQA is nothing if not clever, for it takes advantage of two soft spots in administrative law: agency delay and agency bad faith.

Delay

The Board of Supervisors' vote to reverse certification of the Stevenson St. EIR was tantamount to saying, "We haven't made up our mind about this project, and we need more information before we can make up our mind." When agencies say they need more time to gather information and make up their mind, courts normally let them have it. If an antsy plaintiff sues, the court will say that the suit is premature because there's not yet a "final" agency decision, or because the plaintiff hasn't "exhausted her administrative remedies," or because the case isn't yet "ripe." After all, it would be a waste of judicial resources and a big practical problem for governance if anyone waiting in line for an agency decision could ask a judge to let him jump the queue.

The legal doctrines that prevent plaintiffs from attacking agency delay have exceptions, but the exceptions are very narrow. For example, California courts excuse plaintiffs from exhaustion when further agency proceedings would be "futile" – but only if the plaintiff can "positively state" what the agency has decided (thus rendering further proceedings pointless). The courts have also waived exhaustion when the agency has no legal authority to conduct the proceeding at issue and when pursuit of further proceedings would result in irreparable harm. None of these exceptions fits the Stevenson St. scenario. The Board of Supervisors has carefully avoided "positively stating" its decision; there's no question that the Board is authorized by law to be the city's ultimate decider about the CEQA review; and the irreparable harm exception is applied "only in the clearest of cases."

It's also true that if the Legislature prescribes clear-cut timelines for an agency decision, a plaintiff can, in theory, use "traditional mandamus" to get a court order requiring the agency to act. But as we illustrated in yesterday's discussion of Schellinger and the CEQA timelines, these cases make courts uncomfortable. At most, a court will order the agency *to make a decision*, as opposed to telling the agency *what to decide*. And if there's an available equitable doctrine like laches that would let the agency off the hook, the courts will gladly invoke it.

Bad Faith

The other formidable barrier to a judicial fix for CEQA-laundered project denials is the principle that courts should review agency decisions solely on the basis of the reasons stated by the agency at the time of the decision, rather than probing to figure out the agency's real reason and setting the decision aside if the real reason was not authorized by law.

To the extent that the Board's decision to require further CEQA study of the 469 Stevenson project is reviewable at all, a court would normally uphold the decision so long as the "findings" prepared by the clerk include *some* legitimate reason for additional CEQA study. The stated rationale must also draw *some* support from the record of materials before the Board, but the evidentiary demand is lax. If a reasonable person could agree with the Board's decision in light of the evidence in the record, courts generally will accept it.

In federal administrative law, there is a narrow exception to these general precepts. Upon a “strong showing of bad faith,” a court may peer behind the agency’s rationale and the record of contemporaneous materials the agency assembled to justify it. If the court concludes from this investigation that the agency’s stated reasons were pretextual, the court may set aside the agency’s decision – even if the stated reasons, if real, would have sufficed to justify it. This obscure doctrine enjoyed a moment of renaissance when Chief Justice Roberts invoked it to invalidate the Trump Administration’s addition of a citizenship question to the U.S. Census. But even as the Chief Justice insisted that courts “are ‘not required to exhibit a naivete from which ordinary citizens are free,’” he was at pains to limit the bad-faith exception.

It is for very good reasons that the bad-faith exception is narrow. Much like aggressive judicial review of agency delay, courtroom trials focused on the “real reasons” for agency action would gum up the work of government. Discovery requests and depositions would divert public officials from their primary charge. Courts would struggle to disentangle the mix of political and policy-minded considerations that shape agency decisionmaking – especially when the leaders of the agency in question (a city council) are elected officials who inevitably pay attention to politics even when acting in a quasi-judicial capacity (hearing a CEQA appeal).

Finally, it’s black-letter law that when an agency messes up, the judicial remedy is to vacate the agency’s decision and remand for a do-over. Even in the Census case, the Court *did not* strike the citizenship question from the Census: it just told the Commerce Department to try again. But what does this achieve if the agency is in bad faith? A court order telling San Francisco’s Board of Supervisors to rehear the 469 Stevenson St. CEQA appeal would be an invitation to re-laundry the denial, minus the revealing tweets.

But the HAA’s a Game Changer, Right?

The foregoing ought to douse any hope one might have about using general legal principles to curtail CEQA-laundered project denials. But when the project getting laundered is a *housing project*, a court must consider the Housing Accountability Act as well. And the HAA gives the general principles of administrative law a real shakeup, reworking some and tossing others in the garbage:

- The HAA expressly authorizes judicial inquiry into bad faith. “Bad faith” as defined by the Act includes “an action that is frivolous or otherwise entirely without merit.” This means that a court can find bad faith without subpoenas, depositions, or other searching inquiry into the mental processes of city council members. If the denial of a project was objectively frivolous, that’s enough.
- In cases where a court finds bad faith, the HAA supplants the traditional do-over remedy. It authorizes courts to order the project approved--and to retain jurisdiction to ensure that this order is carried out.
- The HAA provides at least a partial remedy for delay, by defining “[d]isapprove the housing development project” to include “[f]ail[ing] to comply with the time periods [for project review] specified in [the Permit Streamlining Act].”

- The HAA eliminates judicial deference to local governments on all questions about whether a housing development project complies with applicable standards.

The HAA's stance is one of extreme distrust toward local governments. In 1982, the Legislature stated that "the excessive cost of the state's housing supply is partially caused by activities and policies of many local governments that limit the approval of housing." But as the Legislature noted in 2017, when it strengthened various provisions, "[t]he Legislature's intent in enacting this section in 1982 . . . has not been fulfilled." Hence the new policy going forward: "that [the HAA] be interpreted and implemented in a manner to afford the fullest possible weight to the interest of, and the approval and provision of, housing."

But there's a catch. While the HAA provides a powerful remedy for a bad-faith project denials, its only explicit remedy for delay is tied to the Permit Streamlining Act. Yet as noted in our [previous post](#), the PSA clock doesn't start to run until CEQA review has been completed, and another provision of the HAA states that the statute shall not "be construed to relieve [a city] from making ... findings required [by CEQA] or otherwise complying with [CEQA]."

How can a court make sense of these conflicting directives? In the rest of this post, we sketch three possible solutions.

Solution #1: Bad-Faith Delay Through CEQA Reversal as HAA "Disapproval"

A court following the Legislature's command to "interpret[] and implement[]" the HAA "to afford the fullest possible weight to the interest of ... housing" could hold that a city's delaying of a project in bad faith amounts to "disapproval" within the meaning of the HAA, at least if the delay occurs through a negative vote on a formal approval that a developer needs to reach the finish line.

The HAA's definition of "disapproval" is broad. It includes "any instance in which a local agency . . . votes on a proposed housing development project application and the application is disapproved, including any required land use approvals or entitlements necessary for the issuance of a building permit." The certification of an EIR or other CEQA clearance is one of many "approval[s]" or "entitlement[s]" which a developer must obtain before eventually landing a building permit. And it is an approval that a city council reversing a CEQA clearance "votes" to deny.

The HAA's remedial provisions imply that the statute may be violated other than by final denial of an application for a project entitlement or building permit. A court that finds a violation "shall issue an order ... compelling compliance with this section within 60 days, including, but not limited to, an order that the local agency take action on the housing development project." The "but not limited to" proviso suggests that a city may violate the HAA by taking unlawful action (or inaction) on ancillary matters necessary for the project to go forward, and it instructs courts to use their powers flexibly to remedy whatever violations a court finds.

On the other hand, the fact that the HAA doesn't expressly list "legally inadequate CEQA analysis" as a permissible ground for disapproval of a housing development project suggests that the Legislature may not have thought that a city council's reversal of a CEQA certification would qualify as a housing-project disapproval. But the HAA in its current incarnation is meant to be a super-statute, "interpreted and implemented in a manner to afford the fullest possible weight to the interest of, and the approval and provision of, housing." This interpretive instruction, together with the parallel legislative finding that local governments have for too long managed to evade the Legislature's intent to "meaningfully and effectively curb[] [their] capability ... to deny, reduce the density for, or render infeasible

housing development projects,” suggests that the Legislature wants courts to read the statute flexibly as may be necessary to countermand evasive local tactics the Legislature did not anticipate.

A line-drawing problem remains: it can't be true that every city council vote sustaining a CEQA appeal is a “disapproval” within the meaning of the HAA. Some appeals are meritorious. In other cases, a city council may reasonably believe that an appeal has merit, even if some judges would disagree. At what point does a city council's reversal of a legally sufficient CEQA clearance become an HAA “disapproval”? The HAA's remedial provisions point toward an answer: when the CEQA reversal is in bad faith. Like the party to a contract who commits anticipatory breach, the city that denies a CEQA clearance in bad faith signals that it has no intention of performing its legal obligation under the HAA.

If a court reads “disapproval” to include bad-faith denial of a CEQA clearance, and finds that San Francisco's Board of Supervisors pretextually reversed the EIR certification for 469 Stevenson St., the court could order the project approved, because the HAA supplants the conventional do-over remedy in cases where a city has denied a project in bad faith.

One might object that this gloss on HAA “disapproval” would “relieve[]” the city of compliance with CEQA. Not so. San Francisco's planning department prepared a full EIR for 469 Stevenson St., which the planning commission certified as complete. So long as the court concludes that the EIR was in fact legally sufficient, an order directing the city to approve the project would do no violence to the HAA's CEQA-preservation clause. The court could also allow the Board of Supervisors a brief window of time to decide whether to impose any additional mitigation requirements on the project, in light of the findings of the EIR. This would honor CEQA's policy that elected officials bear final responsibility for deciding what to do about identified environmental impacts.

Another counterargument is that the Board in voting to reverse the EIR certification didn't actually determine whether the project could go forward or what its density would be. It just said it wanted more information. This argument would be a strong counter under general administrative law principles. But in taking a practical, real-world approach to “disapproval,” the HAA undercuts it. For example, delay beyond the time limits of the Permit Streamlining Act is explicitly an HAA disapproval, even though such delay doesn't entail any concrete act or statement of reasons by the city. A formal vote reversing a CEQA clearance is much closer to the conventional paradigm of a discrete, reviewable agency action.

In its first letter to San Francisco after starting to investigate the 469 Stevenson St. debacle, the Department of Housing and Community Development signaled support for reading “HAA disapproval” to include pretextual CEQA-clearance reversals. If an agency that the Legislature has authorized to enforce the HAA concludes that bad-faith denials of CEQA clearances are “disapprovals within the meaning of the HAA, a court need not go out of its way to conclude the same.

Solution #2: Enforcing CEQA Timelines in Light of the HAA

Without reaching the question of whether bad-faith denial of a CEQA clearance is “disapproval” within the meaning of the HAA, a court could hold that the Legislature's refashioning of the HAA as a super-statute warrants revisiting – and limiting or rejecting – the Court of Appeal's decision in Schellinger Brothers v. City of Sebastopol. Burying Schellinger is necessary to give practical effect to the HAA's incorporation of the Permit Streamlining Act's timelines into the definition of disapproval.

As we explained in yesterday's post, Schellinger held that judges may not order a city to certify an environmental impact report (as opposed to ordering the city to make up its mind about whether to certify it). The court also said

that the project applicant had, by cooperating with the city and making revisions well past CEQA's deadline, forfeited its right to enforce the deadline.

The most basic problem with *Schellinger* is that it makes a hash of the statute's definition of "disapproval." As noted, the HAA defines disapproval to include noncompliance with the PSA deadlines, but the PSA clock only starts to run after CEQA review is done. So if there's no practical way of forcing cities to comply with CEQA's deadlines, then the delay-oriented piece of the HAA's definition of disapproval is a dead letter. That doesn't benefit any statute, let alone one which the Legislature has declared to be super.

As for *Schellinger's* "equitable" holding (that the developer who cooperates past a deadline forfeits her right to enforce it), equitable doctrines are not supposed to be used in ways that "nullify an important policy adopted for the benefit of the public." Whatever might have been said about the HAA when *Schellinger* was decided in 2009, there is no gainsaying that, today, the Act's policy of expeditious permitting is "important" and inures to the "benefit of the public."

CEQA allows one year for completion of an EIR. A recent study of housing project entitlements in twenty California cities found that the median project in San Francisco took 27 months to entitle; only 5% were entitled in under a year. 469 Stevenson St. is more of the same. The final EIR for the project wasn't certified by the planning commission until nearly three years after the developer's submission of the project application. And then came the appeal to the Board of Supervisors, resulting in further delay.

Bearing these facts in mind, and reading CEQA in light of the newly "super" policy of the HAA, a court might reasonably hold (1) that the CEQA deadlines are enforceable regardless of whether the developer has cooperated with the city past the deadline (contra *Schellinger*), and (2) that if the CEQA deadline has passed and a legally sufficient environmental review document has been prepared, the city must certify it.

The second holding might seem to depart from the background norm that a court can only order an agency to act, rather than telling it how to act. But sometimes only one course of action is available to the agency, in which case a court may direct the agency to do what the law requires it to do. And what we're proposing is that courts read the CEQA deadlines, in light of the HAA, as creating a ministerial duty to certify any legally sufficient environmental review document once the deadline for completing CEQA review has passed.

The courts could also give cities a brief window to decide what changes to the project or other mitigation should be required in view of the environmental study. This splitting of the baby – letting the politicians choose mitigation but not legally unnecessary environmental study past the CEQA deadline – would go a good distance toward reconciling CEQA with the HAA. It would breathe some life into the PSA deadlines (which the HAA incorporates into its definition of disapproval), without impinging on municipal authority to impose mitigation conditions on development approvals (which the HAA countenances so long as they don't reduce the project's density).

Solution #3: Levering "Pretext" for Judicial Review of the City Council's CEQA Reversal

Our third solution is inspired by Chief Justice Roberts's opinion in *Department of Commerce v. New York*. Instead of putting an expansive gloss on HAA "disapproval," or battling *Schellinger* to make the CEQA deadlines judicially enforceable, a court would hold that CEQA reversals are reviewable for pretext in limited circumstances.

Specifically, a plaintiff's "strong showing of bad faith" would render a city council's CEQA reversal reviewable, and, if the court determines that the city council acted in bad faith, the court would hold the council's decision unlawful.

This solution invites a number of questions. First, is it even available in California? Second, once the door has been opened to pretext inquiries in this context, what's to keep them from spreading across all of state administrative law, at a high cost to courts and agencies alike?

Third, would this solution make a difference, given that the standard remedy in CEQA cases is a remand for a do-over – which is basically an invitation for the bad-faith agency to better cover its tracks?

As to the first question: The solution is available in the sense that it hasn't been ruled out by California Supreme Court. Although there's a pretty strong norm against looking behind the official record assembled by an agency, the Court has reserved the question of whether there might be a "limited" exception for "agency misconduct."

The second question – whether pretext claims can be cabined – is serious but not hard to answer. The HAA and the institutions now being erected to enforce it offer guardrails. For example, a court could hold that the HAA's concerns about municipal good faith warrant recognizing "CEQA pretext" claims vis-a-vis HAA-protected projects, if not otherwise. Going a step further, it could hold that the pretext claim is available only if HCD or the Attorney General makes the preliminary "strong showing of bad faith," or otherwise raises serious concerns about the city's development-review processes.

The remedy question concerns us more. If a court finds that a city's CEQA reversal was pretextual, must it send the whole thing back and give the city another chance to dress up its decision, exactly as the U.S. Supreme Court did with the Census case? Not necessarily. The California Supreme Court has endorsed the "inherent power" of a trial court to send only part of a decision back to the agency, while retaining jurisdiction to issue judgment later. Perhaps a court in a pretext case could treat a CEQA certification as mostly complete (and valid), retain jurisdiction, and give the city a short period of time to address any legitimate concerns identified by the court on a limited remand. This would light a fire under the city and ensure that the case comes back to the same judge.

As motivation for this or another nonstandard remedy, consider what courts do when a decision-maker is found to have prejudged the facts or otherwise manifested bias in violation of due process. Normally the court disqualifies the biased arbiter and remands for a fair hearing before another hearing officer. The Court of Appeal has said that a city's "malicious[] or arbitrar[y]" refusal to certify a CEQA document violates the developer's right to due process. If that's right, a city council's bad-faith reversal of a CEQA certification violates due process too, and the biased decision-maker should be disqualified on remand. But a court generally cannot disqualify the whole decision-making body that must decide the case (as is true under CEQA), so there is no analogous remedy if a quorum of the council has shown bad faith. Hence the need for innovation beyond the usual do-over remedy.

All that said, the judicial norm against telling agencies what they must do is very strong, and without specific textual authorization – e.g., the HAA directing courts to order projects approved, or CEQA specifying deadlines for completion of environmental review – we fear that judges would be reluctant to deviate from the standard remedy, even in a pretext case.

One more point about remedies is worth mentioning. A bad-faith CEQA reversal that violates due process would make the city liable for damages. The prospect of having to compensate a developer for holding costs, and for the expense of the additional environmental studies, might be enough to discourage some cities from trying to launder housing denials through CEQA.

* * *

After a forty-year saga, the HAA is at a moment of truth. Will courts nodding to background principles of administrative law stand by while city councils deny 500-home projects on frivolous environmental grounds? Or will courts wake up to the HAA's ditching of the old ways and appreciate – finally – that housing is the rare domain in which city councils are not to be trusted at all?

Christopher S. Elmendorf & Tim Duncheon Dec 2 11 min read

Calibrating Environmental Review to the Scope of Municipal Discretion Under the HAA

This is the last in a four part series. SLoGLaw thanks Chris Elmendorf and Tim Duncheon for this timely treatment of the important issue of affordable housing for California, and urban regions around the country--Ed.

The California Environmental Quality Act (CEQA) requires state and local agencies that have discretion to choose among possible options to study environmental effects before making their choice. In theory, this leads to better agency decisions. (A contestable claim – but that’s for another day.) But when other laws require an agency to select a particular option, CEQA doesn’t apply. There’s no reason to write a detailed list of the pros and cons of different options if you know from the start exactly which choice you have to make.

When a developer submits a housing proposal, the Housing Accountability Act (HAA) substantially limits the choices open to the city. So you would think that review under CEQA would be limited accordingly. You would, unfortunately, be wrong – at least as revealed by current practice.

So it is that a proposal to build 500 apartments on a downtown San Francisco parking lot, a block from the subway, in a designated “priority development area” under the region’s climate plan, ended up mired for years in the most extensive and costly form of environmental review required by CEQA: the Environmental Impact Report (EIR).

And why? Because San Francisco’s planning department had concluded, on the basis of a 342-page Initial Study, that a “fair argument” could be made that the Stevenson St. project may have a significant local environmental impact in the form of shadows, wind, or (during construction) noise and air pollution. The Initial Study evaluated the project’s potential impact relative to current environmental conditions nearby. It did not ask whether the project would have a significant marginal impact, relative to any other project of the size that the HAA entitles the developer to build on the site.

If the Stevenson St. project’s marginal impact would be close to nil (as we think likely), then the EIR was an environmentally pointless exercise. Its real function, apparently, was to give local activists and city officials a way to tie up the project until the developer either walked away or paid off TODCO, the politically connected nonprofit that led the charge against it.

The argument of this post is that the scope of CEQA review of housing development projects should be tailored to the scope of municipal discretion. A housing project should require an EIR only if the city exercises discretion to shape the project in some way that generates a significant marginal impact, relative to what the HAA compels the city to approve.

Our approach would not “relieve local governments from complying with” CEQA. But it would require overturning or significantly limiting several judicial precedents that have been incorporated into the official CEQA Guidelines. As such, our proposal poses a stark test of whether the HAA really is a super-statute, one that “sticks in the public culture” and exerts “a broad effect on the law.” If courts and the gubernatorial appointees responsible for the CEQA Guidelines get behind our approach, then the HAA will in fact “meaningfully and effectively curb[] the capability of local governments” to hobble housing development projects. If they do not, there can be little doubt that NIMBY cities will become ever more expert at exploiting CEQA to undermine the HAA.

“Effect” Relative to What?

We begin with an elementary point about causation. It is senseless to try to characterize the environmental effect of a proposed housing project without comparing it to some alternative use of the site. Consider an analogy: What is the effect of a new drug or medical device? The answer depends on what you’re comparing it to. Relative to a placebo, the effect of the new drug may be large. Compared to the best treatment currently in use, the effect of the very same drug could be small or even negative.

The same goes for housing projects. They have effects only when they’re compared to some alternative. Let’s call the point of comparison the reference alternative. What is conventionally labeled “the baseline” in an environmental impacts study is, properly understood, a compound of two things: an alternative use of the site (the “reference alternative”) and a projection of environmental conditions in and around the site conditional on that use of it.

CEQA analyses, relying on CEQA caselaw, usually elide this fundamental point. By convention, they purport to measure the “effect” of a project relative to “current environmental conditions” on the site and in its vicinity. This is a misleading point of reference if current environmental conditions would change absent the project. No medical researcher would measure the “effect” of an experimental treatment by comparing the health status several years in the future of elderly patients who received the treatment with their health at the time the treatment was administered. That comparison would obscure the effect of the treatment, because old people tend to decline as they age.

The CEQA analyst’s conceptual mistake about baselines is not a problem in contexts where the permitting agency has authority to deny the project and doing so would maintain current environmental conditions. In such circumstances, the current-environmental-conditions baseline is equivalent to treating the “no-action alternative” as the reference alternative. This is like a placebo reference condition in a drug trial.

But the current-environmental-conditions baseline is nonsensical when the public decisionmaker lacks legal authority to maintain it. This is precisely the situation that cities face when developers propose HAA-protected housing projects. Cities may place discretionary conditions of approval on such projects, but they may not deny the project or reduce its density. Accordingly, the environmental impact of the project should be gauged relative to a reference-alternative project of the scale the city is required by law to approve.

An HAA-Informed Protocol for CEQA Review of Housing Projects

The first step in CEQA review is preparation of the Initial Study, which seeks to determine whether there is a “fair argument” that the proposed project “may” have a significant impact on the environment. If the answer is “Yes,” then the project proponent must pay for an EIR that fully analyzes the potential effects identified in the Initial Study.

The policies of the HAA and the policies of CEQA can be reconciled, to some extent, by asking the threshold HAA question at the outset of the Initial Study: Does the project as proposed comply with applicable, objective general plan, zoning and development standards, as defined in the HAA? If it does, the city may deny or downsize the project only if it violates a written, objective health or safety standard within the meaning of the HAA. So for zoning-compliant projects, the Initial Study should gather information about potential health / safety violations and determine whether a preponderance of the evidence establishes a violation. A conventional CEQA review is in order only if such a violation is established (because the city may deny the project).

For projects that comply with general plan and zoning standards, and that don't violate health or safety standards, it's meaningless to conduct an environmental review that benchmarks the project against a no-action alternative or "current environmental conditions" in the vicinity of the site. The city's discretion is limited to altering the project with conditions of approval that do not reduce its density, and the CEQA baseline should be defined accordingly.

There are two plausible reference alternatives in this circumstance. First, the analysis could proceed using a project-as-proposed benchmark. The reviewer would inventory any discretionary conditions of approval that the city is considering imposing on the project, and then benchmark (1) environmental conditions if the project goes forward with the discretionary condition(s) imposed, against (2) environmental conditions if the project goes forward in the form it was proposed. The difference represents the environmental effect of the city's exercise of discretion.

To illustrate, if the city were considering a discretionary condition of approval that would require rooftop solar panels, and concerns were raised about glare from the panels, the Initial Study would undertake to determine whether there is a fair argument that the rooftop solar condition may cause a significant environmental impact in the form of glare, relative to the scenario in which the city approves the project in the form it was proposed.

Alternatively, the city could posit a green-reference benchmark, measuring the impact of an HAA-protected project relative to a model "green" project of the same density on the same site. The green-reference alternative might be defined as a project that provides the minimum number of on-site parking spaces; that uses low-energy building materials; and that minimizes impermeable ground cover (insofar as the city has authority to impose such conditions). The key point is that the green reference alternative would be a legally available option, and as such represents an informative benchmark against which to compare the proposed project.

Under either model, it would be the rare HAA-protected project that requires an EIR. Cities do not often impose conditions that reduce environmental amenities in the vicinity of a project, so the project-as-proposed benchmark would yield *pro forma* negative declarations in most cases. As for the green-reference benchmark, developers who anticipate opposition from neighbors, unions, or other interest groups would likely conform their proposal to the benchmark. If the project as proposed is HAA-protected and uses the green-reference design, then by construction it would have no environmental effects for CEQA purposes.

Does CEQA Allow It?

The idea of tailoring the scope of environmental review to the scope of agency discretion has precedent under statutory analogues to CEQA at the national level and in New York. Review under the National Environmental Policy Act (NEPA) is limited to "effects" that are proximately caused by the agency's discretionary choices. Thus, in *Department of Transportation v. Public Citizen*, the U.S. Supreme Court held that an environmental impact study prepared by the Department in connection with the North American Free Trade Agreement need not analyze pollution resulting from an increase in Mexican truck traffic, because the Department had no legal authority to exclude Mexican trucks. To date, no California court has ruled on whether CEQA incorporates the proximate-

causation theory of *Public Citizen*, but California courts do seek guidance from NEPA precedents when tough questions arise under CEQA.

In New York, courts got to a similar place by rejecting the “no-build baseline” in cases where the project proponent may build something as of right. Specifically, if a developer proposes an office or residential building that would require rezoning, on a site where a smaller building is allowed as of right, the effect of the proposed project is analyzed relative to the “as-of-right alternative” rather than the “no-build alternative” or “current environmental conditions.” Because the city lacks authority to deny the smaller project, it would be uninformative to conduct an environmental review using a no-project baseline.

Like the National Environmental Policy Act and New York’s State Environmental Quality and Review Act, CEQA exempts “ministerial” permits from environmental review. Discretion is always the trigger. However, the Court of Appeal has held in several cases that if a city has any discretion to shape a project, the city must analyze and mitigate the impact of project “as a whole” relative to a current-environmental-conditions baseline. Projects whose permitting is “not wholly ministerial and not entirely discretionary but a compound of both” have been treated as entirely discretionary for CEQA purposes. In one case, an EIR was produced using a zoning-complaint project baseline, similar to New York practice, and the California Court of Appeal rejected it out of hand. The court faulted the EIR for not “present[ing] a clear or a complete description of the project’s impacts compared with the effects of leaving the land in its existing state.”

This line of cases is rooted in CEQA’s traditional premises: that new construction is bad for the environment, and that CEQA should be construed broadly to give “the fullest possible protection” to the environment. The working assumption is that requiring more environmental review and mitigation is the greener way. But as we’ve seen, the HAA inverts this premise when it comes to housing. The HAA declares new construction of zoning-compliant housing projects to be presumptively good for the environment, and it aims to “meaningfully and effectively curb[] the capability of local governments to deny, reduce the density for, or render infeasible housing development projects.” A reading of CEQA that leaves cities with open-ended discretion to require time-consuming studies and costly mitigation of so-called “impacts” that are not even proximately caused by the city’s exercise of discretion would do pointless violence to the policy of the HAA.

In the near term, however, any effort to use the HAA to put a limiting gloss on misbegotten CEQA-baseline precedents would be complicated by the fact that those precedents are now codified in the official CEQA Guidelines. The Guidelines stipulate that “the physical environmental conditions in the vicinity of the project, as they exist at the time the notice of preparation [of the EIR] is published . . . will normally constitute the baseline physical conditions by which a lead agency determines whether an impact is significant.” This “existing conditions baseline” “shall not include hypothetical conditions, such as those that might be allowed, but have never actually occurred, under existing permits or plans.”

The only exception that the Guidelines presently recognize is that an agency may use a “projected future conditions ... baseline ... if it demonstrates ... that use of existing conditions would be either misleading or without informative value to decision-makers and the public.” This exception codifies a practice that developed around very long-term projects, such as railways. Neither the Guidelines nor any published case approves the use of a “future-conditions baseline” where the future in question is a build-out of the project site under an alternative development scenario. Then again, neither the Guidelines nor any published case has considered the implications of the HAA for CEQA baselines or causation.

Though it wasn't written for the HAA problem, the Guidelines' narrow allowance for "future conditions" baselines at least recognizes that circumstances may arise where the conventional baseline is inappropriate. And the crux of our argument is that it is misleading and uninformative – and a colossal waste of resources, and a serious threat to the environmental and housing policies of the HAA – to require developers to engage in a multi-year analysis of putative environmental "effects" that are the byproduct of a nondiscretionary statutory mandate, not the discretionary choices of the local permitting authority itself.

The Governor's Role

Courts are conservative creatures. It's not in their nature to upend long-established precedents just because those precedents are at odds with another statute the Legislature has declared to be super, but which also preserves the statute that spawned the bad precedents.

But courts don't implement CEQA by themselves. CEQA authorizes the Governor's Office of Planning and Research and the Natural Resources Agency to issue implementing guidelines. The CEQA Guidelines codify judicial precedent, but they also embody policy choices, and the courts give measured deference to such choices. If environmental review is to be reshaped by an HAA-informed theory of causation, the Guidelines are the best tool at hand.

The Guidelines are a good tool for this purpose not only because making policy and changing direction is, by tradition, more squarely in the agency wheelhouse than the judicial wheelhouse, but also because of politics. Through his appointments and directives, the Governor can shape the Guidelines. And, presently, the Governor is better positioned than any other state-level actor to navigate the politically treacherous waters of CEQA reform.

Though it was a noble environmentalism that made CEQA super in the 1970s, the continued strength of CEQA today has much to do with the constellation of interest groups – first and foremost the building-trades unions – that have mastered the art of using CEQA to extract costly concessions from developers. In expensive housing markets, the threat of CEQA litigation and delay can be used to make developers sign project-labor and "community benefit" agreements with influential unions and nonprofits. The building trades wield a lot of power in Sacramento, and in recent years they've derailed every legislative proposal for CEQA reform or streamlining except those that require qualifying projects to use union labor. Not even a trivial bill that would let churches build affordable housing without CEQA review could escape Labor's grip.

But Governor Newsom is riding high. He was elected by a twenty-four point margin. He defeated the recall attempt by the same margin. The California Republican Party is all but dead, and the odds that the Governor will face a strong Democratic challenger when he's up for reelection in 2022 are remote. A tussle with the building trades wouldn't derail his career.

Of course, no Governor can single-handedly make the HAA "stick" in a manner that limits abusive use of CEQA. If there were a legislative consensus that project-labor agreements are more important than housing production, the Legislature could quickly abrogate any reformist CEQA Guidelines and then override a gubernatorial veto. But it's a fair hope that no such veto-proof consensus exists. The Republican minority is no fan of CEQA, and Democratic legislators are loathe to override their co-partisan Governor. Moreover, politically vulnerable legislators, who wouldn't dare cast a roll call vote against the trades, may acquiesce in the appointment of pro-housing committee chairs, who in turn could block any bill that would reverse the Governor's reform of the CEQA Guidelines. It's also possible that a transparent, public debate about CEQA abuse – a debate that would probably accompany any

legislative effort to roll back the reformed Guidelines – might itself subtly alter the politics of CEQA reform, in a way that gives the HAA the upper hand.

Although super-statutes on Eskridge and Ferejohn’s telling embody great normative principles, it appears that CEQA’s continued potency owes much to a small number of rent-seeking interest groups that depend on it. The generational clash between the HAA and CEQA is about power as much as principle.

Most Popular

1. California to reimpose statewide indoor mask mandate as omicron

2. Breed tries to rein in S.F. school board with unprecedented charter...

3. Atmospheric river rolls into Bay Area. Here's when and where storms are...

4. Atm S.F. roac



OPINION // OPEN FORUM

How an outdated environmental law is sabotaging California's new housing rules

Christopher S. Elmendorf and Tim Duncheon

Dec. 4, 2021

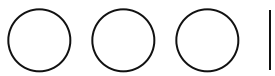



The parking lot at 469 Stevenson St. on Oct. 28, in San Francisco, Calif. The site is currently used as a service parking lot for Nordstrom.

Santiago Mejia/The Chronicle

In October, outrage erupted when San Francisco's Board of Supervisors voted down a proposal to build nearly 500 new homes — many affordable — on a downtown site at 469 Stevenson St. now being used for valet parking.

Of course, these same supervisors reject housing developments all the time. And yet this denial was especially brazen.

ADVERTISEMENT

Article continues below this ad

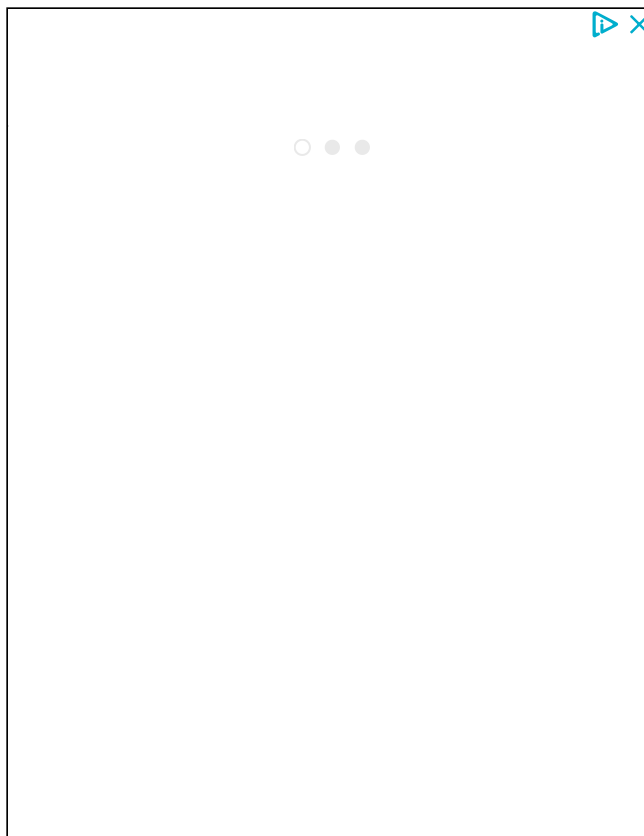

[Skip to main content](#)[Subscribe](#)[Sign In](#)

It came short on the heels of a [major Court of Appeal decision](#) upholding the state's powerful [Housing Accountability Act](#), which requires cities to approve housing projects if a reasonable person *could* deem the project compliant with applicable

standards. Yet the supervisors who voted “no” didn't even try to argue that the project was noncompliant.

GET A JUMP ON 2022! 26 WEEKS FOR 99¢: Unlimited Digital Access

ACT NOW

Instead, they attempted to evade the HAA by using a different law, the [California Environmental Quality Act](#).

Technically, the board voted to reverse the city planning commission's certification of the project's environmental impact report—a report that took over two years to complete and certify in the first place. Board members demanded additional environmental studies, even as they [openly admitted](#) that their objections to the project — too big, not enough affordable units, risk of gentrification — had nothing to do with the environment. [Oakland](#) and [Sonoma](#) have also used similar CEQA maneuvers to hold up housing projects, too, albeit to much less fanfare.

The immediate question this raises is whether cities will be allowed to keep using CEQA to [launder denials](#) of housing that state law protects. Can bad-faith cities keep getting away with demanding round after round of ever more elaborate environmental studies, until developers cry uncle and walk away?

But there's also a deeper question. Why is a housing project that a city can't legally deny — because it is protected by state law — required to undergo an exhaustive environmental study in the first place?

ADVERTISEMENT

Article continues below this ad

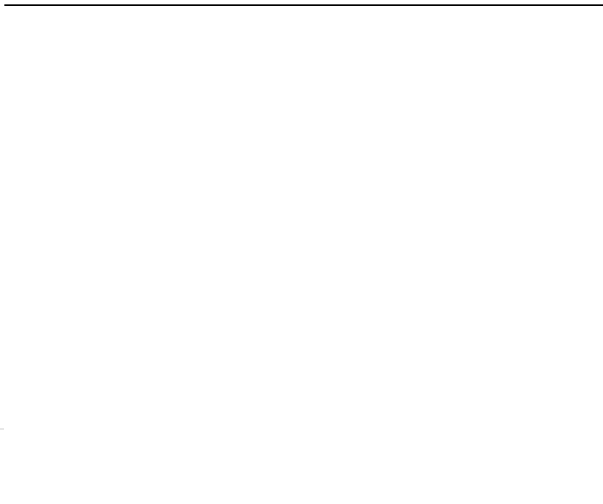

CEQA requires local governments to carefully consider environmental concerns whenever they make discretionary decisions. For example, it requires cities to do environmental studies when they change their zoning ordinances.

San Francisco's city charter subjects all development projects to "discretionary review," making them all potentially subject to CEQA, even if they conform to zoning. But that doesn't mean every single project in San Francisco is put through the wringer of a multiyear environmental impact report. A report is required only if the development may have a "significant impact" on the environment.

But significant relative to what?

The developer of the Stevenson Street project had to complete an environmental

impact report because San Francisco's Planning Department concluded (after its own yearlong, 342-page study) that the building might have a significant local environmental impact in the form of shadows, wind, or (during construction) noise and air pollution, relative to leaving the site as a parking lot.

This is nuts.

After all, this was a proposal to put dense housing a block from a BART station, in a designated "priority development area" under the region's climate plan. Few projects could be more environmentally friendly.

Also, critically, California law doesn't allow the city to retain the site as a parking lot once a developer applies to build housing there.

There was no reason to require an environmental impact report for the Stevenson Street project unless it would have a significant larger impact than *any other* project of the size that state law authorizes and encourages developers to build on the site. If the impact of the 500-home building the developer proposed would be about the same as the impact of any other 500-home building on the site, then requiring the developer to prepare an environmental impact report was a colossal waste of time (two years and counting) and money. In the midst of a worsening housing crisis.

It doesn't have to be like this.

Under the federal statute on which CEQA was modeled, environmental review is limited to effects that are proximately caused by a government agency's discretionary decisions. Because California law prohibits San Francisco from downsizing the Stevenson Street project, the project's size isn't caused by the city's permitting discretion. And so the Stevenson Street project wouldn't require environmental analysis.

Or consider New York, where if a developer proposes a 10-story development on a site where the zoning currently allows a five-story building, the effect of the larger project is analyzed relative to a smaller one the zoning allows.

The bottom line is that there's an urgent need for fresh thinking about how to fit CEQA and the HAA together in a sensible way. Ideally, California's Legislature would do it, with clarifying amendments to one or both laws. But achieving meaningful CEQA reform through the Legislature has proven to be a Sisyphean task due to the powerful interest groups — first and foremost the building trades unions — that have mastered the art of using CEQA litigation to hold developers hostage until the unions secure a side-deal, thereby making housing harder to build — and more expensive when it is built.

About Opinion

Guest opinions in **Open Forum and Insight** are produced by writers with expertise, personal experience or original insights on a subject of interest to our readers. Their **views do not necessarily reflect** the opinion of The Chronicle editorial board, which is committed to providing a diversity of ideas to our readership.

Read more about our transparency and ethics policies →

Action on this issue will require a full-court press by other actors: the courts, the Attorney General, and most importantly Gov. Newsom, who is riding high after crushing the recall attempt.

The governor has tools at his disposal to get the job done. He oversees the Department of Housing and Community Development, which is tasked with enforcing the HAA and other state housing laws. He also appoints the directors of the Natural Resources Agency and the Office of Planning and Research, who in

turn issue the official CEQA Guidelines, which spell out the nitty-gritty of environmental review.

The governor's housing department has launched an investigation of the 469 Stevenson St. debacle. A few days before Thanksgiving, the department delivered a strongly worded letter to San Francisco. This letter suggested that bad faith demands for superfluous environmental studies may violate the HAA. This interpretation — which is plausible but not open-and-shut — would greatly curtail

CEQA-laundered project denials. And it's an interpretation that courts are more likely to accept now that the executive branch of state government endorses it.

The letter is great, but it's just a start.

CEQA guidelines must be revisited, too. They don't even mention the HAA. Worse, they arguably call for full environmental impact reports even when a city has limited discretion over a project.

Stevenson St. is a case in point.

This is no way to run the show in a world where, as the HAA puts it, the lack of abundant infill housing is “undermining [California's] environmental and climate objectives” by causing “urban sprawl, excessive commuting, and air quality deterioration.”

The housing shortage gets worse with each passing month that is wasted on irrelevant environmental review.

One of Newsom's first official acts after trouncing the recall was to sign a spate of new housing bills. Next in line for the governor's signature should be an executive order directing a revision of the CEQA Guidelines in light of the HAA. There's no

time to waste.

Christopher S. Elmendorf is a professor of law at UC Davis. Tim Duncheon is a lawyer based in San Francisco. Portions of this commentary were published on the State and Local Government Law Blog.

Sign up for the Morning Fix newsletter

Top headlines from The Chronicle's newsroom

Email

SIGN UP

By signing up, you agree to our Terms of use and acknowledge that your information will be used as described in our Privacy Policy.

Written By

Christopher S. Elmendorf and Tim Duncheon

[VIEW COMMENTS](#)

Top of the News

California to reimpose statewide indoor mask mandate as omicron arrives

Everyone must wear masks again indoors starting Wednesday until Jan. 15 in California, the state's health and human services secretary said Monday. That includes offices in San Francisco and stores...

BY CATHERINE HO



School of Law
University of California, Davis

400 Mrak Hall Drive
Davis, CA 95616
530.752.0243
<http://www.law.ucdavis.edu>

UC Davis Legal Studies Research Paper Series

When Super-Statutes Collide:
CEQA, the Housing Accountability Act, and Tectonic Change in Land Use Law

December 7, 2021

Christopher S. Elmendorf, Martin Luther King, Jr. Professor of Law, UC Davis
Timothy G. Duncheon, Law Clerk, U.S. District Court, the Northern District of California



When Super-Statutes Collide

CEQA, the Housing Accountability Act, and Tectonic Change in Land Use Law

Christopher S. Elmendorf, Martin Luther King, Jr. Professor of Law, UC Davis
Timothy G. Duncheon, Law Clerk, U.S. District Court, the Northern District of California*

December 7, 2021

Abstract. This Essay explores the slow-motion collision between two statutes at the center of California’s housing crisis: the California Environmental Quality Act (CEQA) and the state’s Housing Accountability Act (HAA). Each statute has a bona-fide claim to being a “super-statute,” one which exerts a “broad effect on the law.” Yet the two statutes came of age in different eras—CEQA in the 1970s and the HAA in the 2010s—and have fundamentally different institutional and normative premises. After tracing the evolution of the statutes, we explore two problems at their intersection: (1) cities’ use of endless CEQA review to launder the denial of housing projects that the HAA means to protect; and (2) analytical disarray as to the correct reference alternative to use in determining whether a city’s approval of an HAA-protected project would cause a “significant” effect on the environment (the statutory trigger for an environmental impact report under CEQA). We propose solutions to these problems that harmonize the two laws – remaining faithful to the text and purpose of CEQA while fulfilling the HAA’s instruction that it be interpreted “to afford the fullest possible weight to the interest of ... housing.” But our solutions are not inevitable. If courts and other actors are not thoughtful about these questions, CEQA may run roughshod over the HAA, crippling California’s efforts to provide more housing and, ironically, to respond to the threat of climate change as well.

* The authors write in their personal capacity and do not represent any position of the University of California or the U.S. District Court of the Northern District of California. We thank Paul Campos, Meryl Chertoff, Sheila Foster, Dan Golub, Rick Frank, Sarah Jones, Moira O’Neill, David Schleicher, and Bryan Wenter for helpful feedback. Portions of this Essay were previously published in blog format at the State and Local Government Law Blog.

Table of Contents

Introduction	3
I. How CEQA and the HAA Became “Super”	8
A. The California Environmental Quality Act	8
B. The Housing Accountability Act	10
II. Does the HAA (or anything else) Provide a Remedy CEQA-Laundered Project Denials? ..	16
A. Capitalizing on Administrative Law’s Achilles Heel	18
1. Delay	18
2. Bad Faith	19
B. But the HAA’s a Game Changer, Right?	21
C. Solutions	23
1. Bad-Faith Delay Through CEQA Reversal as HAA “Disapproval”	23
2. Enforcing CEQA Timelines in Light of the HAA	26
3. Levering “Pretext” for Judicial Review of CEQA-Clearance Denials	28
III. Calibrating Environmental Review to the Scope of Municipal Discretion Under the HAA	32
A. “Effect” Relative to What?	33
B. An HAA-Informed Protocol for CEQA Review of Housing Projects	34
C. Does CEQA Allow It?	36
D. The Governor’s Role	39
IV. Conclusion	42

Introduction

Observers erupted in fury when San Francisco’s Board of Supervisors voted down a proposal to build nearly 500 new homes -- many affordable -- on an empty downtown lot used for valet parking.¹ The Board’s October 2021 vote came short on the heels of a major Court of Appeal decision upholding the state’s Housing Accountability Act (HAA), which the Legislature has greatly strengthened in recent years.² The HAA usually requires cities to approve housing projects that a reasonable person *could* deem compliant with applicable standards, even if other reasonable people might disagree.³

San Francisco evaded the HAA by using a different law, the California Environmental Quality Act (CEQA), to put the downtown project on ice. Oakland and Sonoma have also used the same maneuver, albeit to much less fanfare.⁴ This presages an epic legal clash, which we explore in this Essay.

The HAA and the CEQA both have fair claims to being what professors Bill Eskridge and John Ferejohn call “super-statutes.”⁵ As Eskridge and Ferejohn define it, a super-statute is a law that

(1) seeks to establish a new normative or institutional framework for state policy and (2) over time does “stick” in the public culture such that (3) the super-statute and its institutional or normative principles have a broad effect on the law— including an effect beyond the four corners of the statute.⁶

As we’ll explain in Part I, CEQA became super in the 1970s, thanks to a run of California Supreme Court decisions that construed it broadly so as to give, as the Court saw it, “the fullest possible protection” to the environment.⁷ The HAA began earning its stripes much more recently. The turning point came in 2017, when the Legislature dramatically strengthened the

¹ Annie Gaus, *Supervisors Under Fire: Vote Against Proposed SOMA Apartment Building Sparks Furor, May Violate State Law*, S.F. STANDARD, Oct. 28, 2021; *Editorial: S.F. Supervisors Have Lost Their Minds on Housing. Here’s What Mayor Breed Can Do About It*, S.F. CHRONICLE, Oct. 29, 2021; Gil Durand, ‘Absurdity’: San Francisco Leaders Stall SOMA Housing Project to Preserve Parking Lot, S.F. EXAMINER, Oct. 29, 2021; Heather K. Knight, *S.F.’s Real Housing Crisis: Supervisors Who Took a Wrecking Ball to Plans for 800 Units*, S.F. CHRONICLE, Oct. 30, 2021; Alexis Kosoff, *Why State Lawmakers Are Fired Up over a Derailed S.F. Housing Project*, S.F. CHRONICLE, Nov. 2, 2021; Diana Ionescu, *San Francisco Supes Reject Proposal To Turn Parking Lot Into Housing*, PLANETIZEN, Nov. 23, 2021, <https://www.planetizen.com/news/2021/11/115376-san-francisco-supes-reject-proposal-turn-parking-lot-housing>.

² Cal. Renters Legal Advocacy & Educ. Fund v. City of San Mateo, 68 Cal. App. 5th 820 (2021).

³ CAL. GOV’T CODE § 65589.5(f)(4) & (j)

⁴ See Letter from Daniel R. Golub on behalf of the Housing Action Coalition to the Hon. Barbara J. Parker, Oakland City Attorney, re: 1396 Fifth Street, Oct. 21, 2021 (on file with authors) (challenging city council’s decision to sustain an appeal of the planning commission’s unanimous determination that the housing project was exempt from CEQA); *Sonoma - 149 Fourth St.*, CARLA BLOG, <https://carlaef.org/legal-case/149-fourth-st-sonoma/> (stating that housing organization had settled their HAA claim after “[r]unning] into an unfriendly judge who decided that nothing could overrule a city’s CEQA decision”).

⁵ William N. Eskridge Jr & John Ferejohn, *Super-statutes*, 50 DUKE L.J. 1215 (2000).

⁶ *Id.* at 1216.

⁷ *Friends of Mammoth v. Bd. of Supervisors*, 8 Cal. 3d 247, 259 (1972); *No Oil, Inc. v. City of Los Angeles*, 13 Cal. 3d 68, 75, (1974); *Wildlife Alive v. Chickering*, 18 Cal. 3d 190, 198 (1976).

law and codified that it “be interpreted and implemented in a manner to afford the fullest possible weight to the interest of, and the approval and provision of, housing.”⁸

The ostensible super-ness of the two statutes creates a real predicament for courts and other actors, because CEQA and the HAA could not be more different in their basic institutional and normative principles. Consider this:

- CEQA’s working premise is that “new construction” is bad for the environment.⁹ “Current environmental conditions” in the vicinity of a proposed project should be preserved if at all possible.¹⁰ By contrast, the HAA regards the construction of housing in urbanized areas as presumptively good for the environment. It opens with a legislative finding that local barriers to housing development cause “urban sprawl, excessive commuting, and air quality deterioration,” “undermining the state’s environmental and climate objectives.”¹¹
- CEQA privileges slow, careful, deliberative evaluation of every possible environmental impact. If there is a “fair argument” that a project “may” have any significant local environmental impact, CEQA compels the preparation of an exhaustive environmental impact report (EIR).¹² And if a lawsuit is filed attacking a project’s CEQA clearance, this usually suffices blocks construction while the litigation crawls along.¹³ The HAA calls for speed. It requires cities to notify developers of any general plan or zoning standards a project violates within 30-60 days after receiving the complete project application,¹⁴ and

⁸ S.B. 167, 2017–2018 Reg., Leg. Sess. (Cal. 2017).

⁹ See, e.g., *Friends of Westwood, Inc. v. City of Los Angeles*, 191 Cal. App. 3d 259, 269 (1987) (“the purpose of CEQA is to minimize the adverse effects of new construction on the environment”). This premise is laid bare by the fact that CEQA requires no analysis before a government agency denies a project, see Cal. Pub. Res. Code § 21080(b)(5) (exempting “[p]rojects which a public agency rejects or disapproves”), whereas a full environmental impact report is required if there’s a “fair argument” that the approval of a project “may” have a significant environmental effect on any aspect of the physical environment, no matter how large the project’s countervailing environmental benefits. See *No Oil, Inc. v. City of Los Angeles*, 13 Cal. 3d 68 (1974). Although CEQA codifies a legislative intent that agencies in regulating private activities give “major consideration . . . to preventing environmental damage, while providing a decent home and satisfying living environment for every Californian,” Cal. Pub. Res. Code § 21000(g), the proviso about “a decent home . . . for every Californian” has to date had no apparent effect on the courts’ CEQA jurisprudence.

¹⁰ See CAL. PUB. RES. CODE § 21002 (declaring “the policy of the state that public agencies should not approve projects as proposed if there are feasible alternatives or feasible mitigation measures available which would substantially lessen the significant environmental effects”); 14 CAL. CODE REGS § 15125 (stating that an EIR shall describe existing environmental conditions in the vicinity of the project, and that this description of existing conditions shall normally serve as the baseline for evaluating potential environmental effects of the project).

¹¹ CAL. GOV’T CODE § 65589.5(a). See also CAL. GOV’T CODE § 65589.5(b) (“It is the policy of the state that a local government not reject or make infeasible housing development projects . . . without a thorough analysis of the economic, social, and environmental effects of the action”).

¹² *No Oil, Inc. v. City of Los Angeles*, 13 Cal. 3d 68, 75 (1974).

¹³ STEPHEN L. KOSTKA & MICHAEL H. ZISCHKE, PRACTICE UNDER THE CALIFORNIA ENVIRONMENTAL QUALITY ACT § 23.92 (CEB 2021) (“PRACTICE TIP: Injunctions are often not necessary to prevent work on the project from proceeding. Although the project applicant may start construction while litigation is pending, the applicant proceeds at its own risk. Because an adverse ruling on the merits by the trial court may result in an order enjoining construction, the project applicant may not be willing to start construction before the trial court decides the case.”) (citations omitted)

¹⁴ CAL. GOV’T CODE § 65589.5(j)(2).

it stipulates that violations of the state's Permit Streamlining Act shall be deemed violations of the HAA.¹⁵

- Courts in CEQA cases presume that cities act in good faith (unless the city shortcuts environmental review).¹⁶ When pertinent facts and empirical inferences are disputed, courts give deference to the city's judgment.¹⁷ The HAA distrusts cities. It eliminates the traditional deference courts gave to cities regarding a housing project's compliance with local standards;¹⁸ it prevents cities from using discretionary standards to deny or reduce the density of a project;¹⁹ and it authorizes courts to order the approval of projects that were denied in bad faith.²⁰

So how will the HAA and CEQA fit together? On one view, CEQA must reign supreme, because a longstanding provision of the HAA states, "Nothing in this section shall be construed to relieve the local agency from complying with ... the California Environmental Quality Act."²¹

California courts have sometimes (less than carefully) concluded that such a clause entirely subordinates one statute to another.²²

¹⁵ CAL. GOV'T CODE §§ 65589.5(j) & (h)(6).

¹⁶ This presumption manifests doctrinally as a distinction between *de novo* or "independent judgment" and deferential "substantial evidence" review. On questions where cities are considered trustworthy, the courts review the city's decision deferentially ("substantial evidence"); on questions where cities' competence or good faith is doubted, courts review the city's decision *de novo*. The principal CEQA issues that get *de novo* / independent judgment review are about shortcutting of environmental review, specifically (1) determinations that a project does not require an environmental impact report because there's no "fair argument" that the project may have a significant environmental effect, see STEPHEN L. KOSTKA & MICHAEL H. ZISCHKE, PRACTICE UNDER THE CALIFORNIA ENVIRONMENTAL QUALITY ACT § 6.76 (CEB 2021) (citing and discussing cases); (2) whether an EIR sufficiently discussed a potential environmental impact, see *Sierra Club v. County of Fresno*, 6 Cal. 5th 502, 511 - 16 (2018); and (3) whether the agency complied with the procedural requirements of CEQA, *id.* at 512. Conversely, cities' factual determinations and empirical inferences are reviewed deferentially. *Sierra Club*, 6 Cal. 5th at 511-16.

¹⁷ *Sierra Club*, 6 Cal. 5th at 511-16.

¹⁸ CAL. GOV'T CODE § 65589.5(f)(4); *Cal. Renters Legal Advoc. & Educ. Fund v. City of San Mateo*, 68 Cal. App. 5th 820, 283 Cal. Rptr. 3d 877, 892-95 (2021) (rejecting city's argument for deference on meaning of its design guidelines. and applying HAA's "reasonable person" standard to determine project's compliance).

¹⁹ CAL. GOV'T CODE § 65589.5(h)(8) & (j); *Cal. Renters Legal Advoc. & Educ. Fund v. City of San Mateo*, 68 Cal. App. 5th 820, 283 Cal. Rptr. 3d 877, 890-94 (2021) (reversing city's denial of project because city relied on design guidelines that were not objective).

²⁰ CAL. GOV'T CODE § 65589.5(k)(1) (A)(ii).

²¹ CAL. GOV'T CODE § 65589.5(e).

²² For an illustration of how "reigning supreme" works in practice, consider the Court of Appeal's treatment of the relationship between a different environmental statute (the Coastal Act) and a different housing statute (the Density Bonus Law) in *Kalnel Gardens, LLC v. City of Los Angeles*, 3 Cal. App. 5th 927, 208 Cal. Rptr. 3d 114 (2016). Like the HAA, the Density Bonus Law states that it shall not be construed in derogation of the Coastal Act. *Compare* Cal. Gov't Code 65589.5(e), *with* Cal. Gov't Code 65915(m). However, the Coastal Act provides that the agency in charge of coastal development permits "may not require measures that reduce residential densities below the density sought by the applicant if the density sought is within the permitted density [under local zoning plus state density bonus law], unless the issuing agency ... makes a finding, based on substantial evidence in the record, that the density sought by the applicant cannot feasibly be accommodated on the site in a manner that is in conformity with [the Coastal Act]." Cal. Pub. Res. Code § 30604(f). In *Kalnel Gardens*, the agency denied the housing project on aesthetic grounds without making this infeasibility finding. The court excused the agency from the finding requirement on the theory that an outright denial of a housing project is not a "density reduction." 3 Cal.App.5th at 947. This wordplay move was textually unnecessary (surely reducing density to zero can be described as a "reduction in density") and had the effect of categorically elevating the Coastal Act over the Density Bonus Law,

But, as noted, the Legislature more recently proclaimed that the HAA “shall be interpreted and implemented in a manner to afford the fullest possible weight to the interest of, and the approval and provision of, housing.”²³ To achieve its stated purpose – to “meaningfully and effectively curb[] the capability of local governments to deny, reduce the density for, or render infeasible housing development projects”²⁴ – the HAA must exert gravitational pull on CEQA. The alternative is a world in which cities would have virtually unfettered discretion to use CEQA to delay projects indefinitely, to force project proponents to pay for round after round of expensive environmental studies, and to encumber projects with costly “mitigation” requirements even if the project would be a big environmental win.²⁵

California’s housing and climate goals hang in the balance. Because CEQA focuses government decisionmakers on local environmental issues, it effectively deemphasizes climate concerns, which occur on a longer time horizon and in a more geographically dispersed way.²⁶ Building dense housing in urban areas dramatically reduces vehicle emissions,²⁷ as the HAA recognizes, and alleviates pressure to build in the state’s wildfire-prone “wildland-urban interface.”²⁸ Harmonizing CEQA and the HAA is no mere academic exercise.

* * *

This Essay runs as follows. Part I recounts the evolution of CEQA and the HAA, illustrating their respective claims to super-statute status. We will see that CEQA’s super-ness was revealed in part by its crushing of a pro-development precursor to the HAA, the Permit Streamlining Act.²⁹

notwithstanding pretty clear textual indications that the Legislature wanted the two laws to be integrated with one another. *See* Cal. Pub. Res. Code § 30604(f); Cal. Gov’t Code § 65915(f)(5) & (j).

²³ S.B. 167, 2017–2018 Reg., Leg. Sess. (Cal. 2017); CAL. GOV’T CODE § 65589.5(a)(2)(L).

²⁴ CAL. GOV’T CODE § 65589.5(a)(2)(K).

²⁵ *See infra* Parts II & III.

²⁶ *See* J.B. Ruhl & James Salzman, *What Happens When the Green New Deal Meets the Old Green Laws?*, 44 VT. L. REV. 693, 718 (2020) (“Laws like the NEPA [the federal analogue to CEQA] and the ESA empower environmental protection interests to demand renewable energy projects meet stringent short-term goals--the ‘kill zero bats’ standard--when doing so may jeopardize the long-term goal of saving all the bats, so to speak.”) CEQA also excuses decisionmakers from any obligation to analyze the environmental consequences of maintaining the status quo, *see* CAL. PUB. RES. CODE § 21080(b)(5) (excluding “[p]rojects which a public agency rejects or disapproves”). This leaves cities free to lock in a low-density status quo (or even valet parking lots!) near transit stations, notwithstanding the central importance of infill development for reducing vehicular greenhouse gas emissions.

²⁷ *See* Christopher M. Jones et al., *Carbon Footprint Planning Quantifying Local and State Mitigation Opportunities for 700 California Cities*, 3 URB. PLAN. 35 (2018); NATHANIEL DECKER ET AL., TERNER CTR. FOR HOUSING INNOVATION, RIGHT TIME, RIGHT PLACE: ASSESSING THE ENVIRONMENTAL AND ECONOMIC IMPACTS OF INFILL RESIDENTIAL DEVELOPMENT THROUGH 2030, at 27-29 (2018).

²⁸ By 2050, at the current rate of growth and under current growth patterns, an additional 645,000 housing units will be developed in very high fire-hazard severity zones. KAREN CHAPPLE ET AL., NEXT 10 & UC BERKELEY CTR. FOR COMM. INNOVATION, REBUILDING FOR A RESILIENT RECOVERY: PLANNING IN CALIFORNIA’S WILDLAND URBAN INTERFACE 7 (2021); *see* Greg Rosalsky, *How A Blistering Housing Market Could Be Making Wildfires Even More Dangerous*, NPR, Sept. 14, 2021 <https://www.npr.org/sections/money/2021/09/14/1036085807/how-a-blistering-housing-market-could-be-making-wildfires-even-more-dangerous>.

²⁹ CAL. GOV’T CODE § 65920 et seq.

Part II delves into the problem one of us has dubbed “CEQA-laundered project denials,” now exemplified by 469 Stevenson St. project in San Francisco.³⁰ The municipal strategy of using CEQA to evade the HAA exploits soft spots in CEQA and background principles of administrative law. But we shall argue that the “super” HAA can provide a remedy, either directly or through its gravitational pull on CEQA and administrative law.

Part III contends that the HAA ought to shape environmental impact analysis itself. Because CEQA only applies to discretionary governmental acts,³¹ environmental review for HAA-protected housing projects should consider only impacts caused by discretionary conditions of approval imposed by the city, not all of the impacts that result from adding new dwelling units to the site. This only makes sense: the latter are caused by state law (the HAA), not municipal discretion. Our HAA-informed gloss on the scope of CEQA review would eliminate substantial environmental reviews for the mine run of zoning-compliant housing projects.³²

Our scope-of-review proposal is consistent with CEQA’s first principles, but it would require jettisoning or substantially circumscribing several judicial precedents which have been incorporated into the official CEQA Guidelines.³³ It’s up to the Governor and his appointees at the Office of Planning and Research and the Natural Resources Agency to decide whether to revise the Guidelines. If they do, and if the Legislature acquiesces, then the HAA will truly merit the moniker, “super-statute.” It will have “stuck in the public culture” and exerted “a broad effect on the law.”³⁴

But that is only one possible future. Another is that CEQA swallows the HAA, expelling more fodder for critics who’ve lampooned California’s symbolically liberal but operationally conservative politics.³⁵ Stay tuned.

³⁰ <https://twitter.com/CSElmendorf/status/1454460433671229443>.

³¹ CAL. PUB. RES. CODE § 21080.

³² It’s important to recognize that CEQA does not itself confer discretion on municipal decisionmakers. *See* CAL. PUB. RES. CODE § 21004 (“In mitigating or avoiding a significant effect of a project on the environment, a public agency may exercise only those express or implied powers provided by law other than this division”).

³³ *See infra* notes 230-242 and accompanying text.

³⁴ Eskridge & Ferejohn, *supra* note 5, at 1216.

³⁵ Ezra Klein, *California Is Making Liberals Squirm*, N.Y. TIMES, Feb. 11, 2021.

I. How CEQA and the HAA Became “Super”

Recall Eskridge and Ferejohn’s definition. A super-statute is a law that:

(1) seeks to establish a new normative or institutional framework for state policy and (2) over time does “stick” in the public culture such that (3) the super-statute and its institutional or normative principles have a broad effect on the law—including an effect beyond the four corners of the statute.³⁶

Below, in Section A, we explain how CEQA became a super-statute in the 1970s and then muscled a precursor of the HAA into near-oblivion. Section B takes up the HAA and shows how it’s becoming super today.

A. The California Environmental Quality Act

Enacted in 1970, a year after Congress passed the National Environmental Policy Act, CEQA heralded a transition from Governor Pat Brown’s California -- a land of burgeoning suburbs and massive water and highway construction projects – to the slow-growth California that his son, Jerry, would preside over.³⁷ Whether the Legislature intended CEQA to be a super-statute is open to debate, but, looking back, it’s clear that CEQA did “establish[] a new normative [and] institutional framework for state policy,” and that the framework “stuck in the public culture” and had “a broad effect on the law.”³⁸

Two early judicial decisions launched CEQA on its path to super-ness. In *Friends of Mammoth v. Board of Supervisors*, the California Supreme Court gave a “broad interpretation to the act’s operative language” and extended CEQA to cover private activities (such as homebuilding) that require public permits.³⁹ Next came *No Oil, Inc. v. City of Los Angeles*, which held that CEQA requires preparation of a full environmental impact report “whenever it *can be fairly argued* ... that the project *may* have a significant environmental impact,” not just where the project is likely to have “important” or “momentous” impacts.⁴⁰

Beyond their immediate holdings, *Friends of Mammoth* and *No Oil* stood for a larger principle: that CEQA should be construed broadly and purposefully to give “the fullest possible protection”

³⁶ Eskridge & Ferejohn, *supra* note 5.

³⁷ For an in-depth look at how this transition played out in the California Supreme Court, see Joseph F. DiMento et al., *Land Development and Environmental Control in the California Supreme Court: The Deferential, the Preservationist, and the Preservationist-Erratic Eras*, 27 UCLA L. REV. 859 (1980)

³⁸ Eskridge & Ferejohn, *supra* note 5, at 1216.

³⁹ 8 Cal. 3d 247, 259 (1972).

⁴⁰ 13 Cal. 3d 68, 75, (1974).

to the environment.⁴¹ Although the Legislature has repeatedly tinkered with CEQA,⁴² it hasn't challenged this foundational maxim, which courts continue to invoke to this day.⁴³

CEQA has also had “an effect beyond the four corners of the statute.”⁴⁴ The best example is the courts' reliance on CEQA to disembowel the Permit Streamlining Act of 1977 (PSA),⁴⁵ which was something of a precursor to the Housing Accountability Act.

The PSA originally required cities to approve or deny applications for a “development project” within one year of receiving a complete application, on pain of the project being “deemed approved” as a matter of law.⁴⁶ The Act did not expressly state that an agency's failure to complete environmental review within the one-year period would result in the project's constructive approval, but everything about the statute suggests that this was the Legislature's intention.

Consider, first, that the bill that created the PSA also established time limits for completing and certifying CEQA reviews, the longest of which corresponds to the PSA's one-year limit for approving or denying a development application.⁴⁷ The statute also stated that the PSA's one-year limit for project approval may be waived if the lead agency prepares an environmental impact statement under the National Environmental Policy Act (NEPA), the federal analogue to California's CEQA.⁴⁸ This implies that if a project only requires review under CEQA, it is subject to the PSA's usual one-year limit and constructive approval penalty. Finally, the opening article of the PSA declared, “To the extent that the provisions of this chapter conflict with any other provision of law, the provisions of this chapter shall prevail.”⁴⁹ No carveout for CEQA was provided.

Yet when courts confronted the question of whether a development project could be deemed approved by operation of the PSA notwithstanding the agency's failure to complete and certify an environmental impact report, they answered with a perfunctory no.⁵⁰ Automatic approval in such circumstances would be an unthinkable “drastic” result, the Court of Appeal said, and because the Legislature “did not mention EIR certification in the [PSA's] automatic approval

⁴¹ See, e.g., *Wildlife Alive v. Chickering*, 18 Cal. 3d 190, 198 (1976) (relying on *Friends of Mammoth* and *No Oil* for the proposition, “[W]e have recognized the necessity of interpreting CEQA broadly so as to afford the fullest possible protection to the environment within the reasonable scope of the statutory language”) (internal quotations omitted).

⁴² KOSTKA & ZISCHKE, *supra* note 16, §§ 1.24 - 1.26.

⁴³ See, e.g., *Sierra Club v. Cty. of Fresno*, 6 Cal. 5th 502, 511 (2018) (“The foremost principle under CEQA is that the Legislature intended the act to be interpreted in such manner as to afford the fullest possible protection to the environment within the reasonable scope of the statutory language.”) (internal citations and quotations omitted); *Mountain Lion Foundation v. Fish & Game Com.*, 16 Cal.4th 105, 125 (1997) (holding that CEQA exemptions are to be construed narrowly).

⁴⁴ Eskridge & Ferejohn, *supra* note 5, at 1216.

⁴⁵ Cal. Stats. 1977 ch. 1200.

⁴⁶ Cal. Stats. 1977 ch. 1200, § 1, p. 3995-96.

⁴⁷ Cal. Stats. 1977 c. 1200, § 10, p. 4001.

⁴⁸ In this circumstance, the PSA's time limit for project approval is 60 days following certification of a “combined environmental impact report [CEQA]-environmental impact statement [NEPA].” Cal. Stats. 1977 ch. 1200, § 1, p. 3996.

⁴⁹ Cal. Stats. 1977 ch. 1200, § 1, art. 1, p. 3993 (emphasis added).

⁵⁰ *Land Waste Mgmt. v. Contra Costa Cnty. Bd. of Supervisors*, 222 Cal. App. 3d 950 (1990).

provisions,” the court refused to countenance it.⁵¹ The gravitational pull of the super-statute, CEQA, overwhelmed what should have been a fairly easy inference from the text and structure of the PSA.

In a later case, the Court of Appeal held that CEQA’s time limits could be enforced by mandamus -- if a city sits for years on a completed environmental impact report without taking official action to certify or disapprove it.⁵² But this gesture at the enforceability of the one-year deadline for EIRs was gravely undermined by another Court of Appeal decision, *Schellinger Brothers v. City of Sebastopol*.⁵³ *Schellinger* held that courts may not order a city to certify an environmental impact report (as opposed to ordering the city to make up its mind about whether to certify it).⁵⁴ Even more damningly, *Schellinger* held that the project applicant had, by cooperating with the city well past the one-year deadline, forfeited its right to enforce CEQA’s deadlines.⁵⁵

Nowhere did *Schellinger* acknowledge that developers have an obvious economic incentive to cooperate with cities that exercise discretionary authority over their projects. That the court’s decision had the practical effect of nullifying the PSA for any project that requires an environmental impact report also went unmentioned. The pull of the super-statute had sucked the guts out of the PSA.

B. The Housing Accountability Act

The HAA was far from super as enacted in 1982, though even then it had become clear that cities were putting the breaks on housing production.⁵⁶ The law originally consisted of just two short paragraphs telling local governments to approve zoning-compliant housing projects unless the project would injure public health or safety.⁵⁷ A 1990 amendment added additional protections for affordable projects (today defined as 20% low-income or 100% moderate income).⁵⁸ Among other things, the amendment stipulated that a city may rely on its general plan or zoning to deny

⁵¹ *Id.* at 961-62.

⁵² *Sunset Drive Corp. v. City of Redlands*, 73 Cal.App.4th 215 (1999).

⁵³ 179 Cal.App.4th 1245 (2009).

⁵⁴ *Id.* at 1262-66.

⁵⁵ *Id.* at 1267-70.

⁵⁶ Cal. Legislative Analyst’s Office, California’s High Housing Costs: Causes and Consequences 7 (2015), <https://lao.ca.gov/reports/2015/finance/housing-costs/housing-costs.pdf> (noting that California home prices were 80% higher than the national average by 1980, compared to just 30% higher than the national average in 1970). Since then, there has been extensive literature exploring the political economy and public choice explanations for why so few American cities are pro-development. See, e.g., William A. Fischel, *The Homevoter Hypothesis: How Home Values Influence Local Government Taxation, School Finance, and Land-Use Policies* 1 (2001) (describing the organizing power of local incumbent homeowners); David Schleicher, *City Unplanning*, 122 *Yale L.J.* 1670, 1676-78 (2013) (emphasizing the power individual local legislators have over their districts in the absence of differentiated party competition); Roderick M. Hills, Jr. & David Schleicher, *Balancing the “Zoning Budget”*, 63 *Case West. L. Rev.* 81 (2011) (emphasizing the difficulty of mobilization by developers against seriatim downzonings).

⁵⁷ Cal. Stats. 1982 ch. 1438.

⁵⁸ Cal. Stats. 1990 ch. 1439 (S.B. 2011).

an affordable project only if the city has adopted a state-approved “housing element” to accommodate regionally needed housing.⁵⁹

Subsequent tweaks to the HAA (1) disallowed local governments from denying zoning-compliant projects except on the basis of written health or safety standards;⁶⁰ (2) defined projects as zoning-compliant if they satisfy the objective standards found in the city’s zoning code and general plan as of the date of the developer’s project application;⁶¹ (3) cracked down on certain obvious ruses, such as cities defining zoning-code violations as a health-and-safety violation;⁶² (4) required cities that wrongfully deny an affordable project to pay the prevailing party’s legal fees;⁶³ (5) authorized courts to compel cities to take action on a wrongfully denied project within 60 days;⁶⁴ and (6) authorized courts to fine cities that deny projects in bad faith and continue dilly-dallying after the court’s order.⁶⁵

All of this sounds pretty super, but if the test for a super-statute is that it “sticks” in “the public culture” and “has a broad effect on the law,”⁶⁶ then the HAA did not become a serious candidate until 2016-2017. There had been very few reported cases under the statute, most likely because developers who hope to do business with a city in the future are naturally reluctant to sue it. In 2015, however, a ragtag bunch of self-described “Yimbys” coalesced in San Francisco, discovered the HAA, and started suing suburbs for denying regionally needed housing.⁶⁷ It wasn’t entirely clear whether they even had standing, but the Legislature answered their call and authorized HAA enforcement by “housing organizations.”⁶⁸

A year later, in 2017, the Legislature enacted a trio of bills that dramatically strengthened the HAA and declared it to be super.⁶⁹ Assembly Bill 1515 took up the question of what it means for a housing project to comply with general plan, zoning, and design standards.⁷⁰ The courts had long given deference to cities on such matters, refusing to set aside municipal determinations that a project is noncompliant if any reasonable person could agree with the city’s conclusion.⁷¹ AB 1515 turned that doctrine on its head, defining projects as compliant as a matter of law if any reasonable person could deem the project to comply on the record before the city – notwithstanding reasonable or even strong arguments going the other way.⁷²

⁵⁹ CAL. GOV’T CODE § 65589.5(d)(5).

⁶⁰ S.B. 1711, 1991-1992 Reg., Leg. Sess. (Cal. 1992), now codified as CAL. GOV’T CODE § 65589.5(d)(2) & (j)(1).

⁶¹ S.B. 748, 1999-2000 Reg., Leg. Sess. (Cal. 1999); now codified as CAL. GOV’T CODE § 65589.5(j)(1).

⁶² S.B. 575, 2005-2006 Reg., Leg. Sess. (Cal. 2005), now codified as CAL. GOV’T CODE § 65589.5(d)(2)(A) (declaring that an affordable housing project’s inconsistency with the city’s general plan or zoning ordinance is not, per se, a “specific adverse impact” on health or safety violation of a written health or safety standard).

⁶³ A.B. 369, 2001-2002 Reg., Leg. Sess. (Cal. 2001), now codified as CAL. GOV’T CODE § 65589.5(k)(1)(A)(ii).

⁶⁴ S.B. 748, 1999-2000 Reg., Leg. Sess. (Cal. 1999), now codified as CAL. GOV’T CODE § 65589.5(k)(1)(A)(ii).

⁶⁵ S.B. 575 (2005). S.B. 575, 2005-2006 Reg., Leg. Sess. (Cal. 2005), now codified as CAL. GOV’T CODE § 65589.5(k)(1)(B).

⁶⁶ Eskridge & Ferejohn, *supra* note 5, at 1216.

⁶⁷ CONNOR DOUGHERTY, GOLDEN GATES 93-116 (2020).

⁶⁸ A.B. 2584, 2015-2016 Reg., Leg. Sess. (Cal. 2016), now codified as CAL. GOV’T CODE § 65589.5 (k)(1)(A)(i).

⁶⁹ A.B. 678, 2017-2018 Reg., Leg. Sess. (Cal. 2017); A.B. 1515, 2017-2018 Reg., Leg. Sess. (Cal. 2017); S.B. 167, 2017-2018 Reg., Leg. Sess. (Cal. 2017).

⁷⁰ A.B. 1515, 2017-2018 Reg., Leg. Sess. (Cal. 2017).

⁷¹ *See No Oil, Inc. v. City of Los Angeles*, 196 Cal. App. 3d 223, 243 (1987); CECILY TALBERT BARCLAY & MATTHEW S. GRAY, CALIFORNIA LAND USE & PLANNING LAW 538-40 (36th ed. 2018).

⁷² The new standard is codified as CAL. GOV’T CODE § 65589.5(f)(4).

A companion bill, SB 167, required cities to give prompt written notice to developers of any zoning, general plan, or design standard that the proposed project violates, on pain of the project being deemed to comply as a matter of law.⁷³ SB 167 also narrowed the HAA's carveout for health and safety standards by requiring cities to show by a preponderance of the evidence that the project would in fact violate a specific health or safety standard.⁷⁴ (The previous evidentiary standard gave cities a lot of slack.) Finally, SB 167 codified numerous Legislative findings, including this:

The Legislature's intent in enacting [the HAA] in 1982 and in expanding its provisions since then was to significantly increase the approval and construction of new housing ... by meaningfully and effectively curbing the capability of local governments to deny, reduce the density for, or render infeasible housing development projects.... That intent has not been fulfilled.⁷⁵

And this:

It is the policy of the state that this section be interpreted and implemented in a manner to afford the fullest possible weight to the interest of, and the approval and provision of, housing.⁷⁶

A year later, the Legislature added this:

It is the intent of the Legislature that the conditions that would have a specific, adverse impact upon the public health and safety [within the meaning of the HAA] arise infrequently.⁷⁷

In 2019, the Legislature codified a preliminary application process, allowing developers to quickly establish the date on which the zoning, general plan, and health and safety standards applicable to their project would be locked.⁷⁸ The Legislature also spelled out what it means for a standard to qualify as objective, such that it may be used to deny or reduce the density of a housing project.⁷⁹

All of this certainly evinces a legislative intent to forge a super-statute, but whether the HAA “stick[s]” in the public culture such that ... its institutional or normative principles have a broad

⁷³ S.B. 167, 2017–2018 Reg., Leg. Sess. (Cal. 2017), now codified as CAL. GOV'T CODE § 65589.5(j)(2).

⁷⁴ CAL. GOV'T CODE § 65589.5(j)(1).

⁷⁵ CAL. GOV'T CODE § 65589.5(a)(2)(K).

⁷⁶ CAL. GOV'T CODE § 65589.5(a)(2)(L).

⁷⁷ A.B. 3194, 2017–2018 Reg., Leg. Sess. (Cal. 2018), now codified as CAL. GOV'T CODE § 65589.5(a)(3).

⁷⁸ S.B. 330, 2019-2020 Reg., Leg. Sess. (Cal. 2019); CAL. GOV'T CODE §§ 65943 & 65589.5(h)(5). Originally slated to expire after 5 years, S.B. 330 was extended for another half decade by S.B. 8, 2021-2022 Reg., Leg. Sess. (Cal. 2021).

⁷⁹ CAL. GOV'T CODE § 65589.5(h)(8) (“‘[O]bjective’ means involving no personal or subjective judgment by a public official and being uniformly verifiable by reference to an external and uniform benchmark or criterion available and knowable by both the development applicant or proponent and the public official.”).

effect on the law”⁸⁰ ultimately depends on how other actors respond to it. Will the courts, the executive branch, and local governments also treat the HAA as super?

In September of 2021, the pumped-up HAA passed its first judicial test with flying colors.⁸¹ The City of San Mateo had denied a small condo project on the basis of the city’s Multi-Family Design Guidelines, which prescribe “a transition or step in height” between new multifamily buildings and adjoining single-family homes.⁸² When a nonprofit housing organization challenged the project denial in court, San Mateo argued that the HAA violated both its right to “home rule” under California’s constitution and the prohibition against delegation of municipal authority. In the alternative, the city asserted that the HAA’s definition of project compliance left intact the tradition of judicial deference to cities on questions about the meaning of local ordinances and that the city in denying the project had plausibly “interpreted” its design guidelines to require setbacks the project lacked. A trial court accepted the city’s constitutional and statutory arguments,⁸³ but the Court of Appeal would have none of it.

Before the appellate court, San Mateo and local government *amici* mustered new constitutional attacks on the HAA -- not just home rule and private delegation, but due process too.⁸⁴ It would have been easy for the Court of Appeal to dodge the new issues, but the court reached out and decided all of the constitutional questions – against the city – thereby securing the HAA’s footing going forward.⁸⁵ The appellate court also carefully traced the evolution of the HAA, juxtaposing it against the seeming intractability of California’s housing shortage. It concluded, “The HAA is today strong medicine precisely because the Legislature has diagnosed a sick patient.”⁸⁶

The Legislature’s instruction that the HAA “be interpreted and implemented in a manner to afford the fullest possible weight to ... housing” was reiterated three times in the court’s opinion.⁸⁷

As for San Mateo’s design guidelines, the Court of Appeal held that they were not objective, and, in the alternative, that a reasonable person could deem the project at issue to comply with them.⁸⁸ Hard-eyed independent judicial review, not deference, was the order of the day. “[It would be] inappropriate for us to defer to the City’s interpretation of the Guidelines,” the court

⁸⁰ Eskridge & Ferejohn, *supra* note 5, at 1216.

⁸¹ Cal. Renters Legal Advocacy & Educ. Fund v. City of San Mateo, 68 Cal. App. 5th 820, 283 Cal.Rptr.3d 877 (2021).

⁸² 283 Cal.Rptr.3d at 883-85.

⁸³ Order Denying Petition for Writ of Administrative Mandate at 3-4, Cal. Renters Legal Advocacy & Educ. Fund v. City of San Mateo (San Mateo Superior Court, Nov. 7, 2019).

⁸⁴ Respondents’ Brief in Opposition to Petitioners’ Opening Brief, California Renters Legal Advocacy & Educ. Fund v. City of San Mateo, 68 Cal.App.5th 820 (2021); Amicus Curiae Brief of the Cal. State Ass’n of Counties in Support of Respondent City of San Mateo et al., California Renters Legal Advocacy & Educ. Fund v. City of San Mateo, 68 Cal.App.5th 820 (2021).

⁸⁵ 283 Cal.Rptr.3d at 895-902.

⁸⁶ 283 Cal.Rptr.3d at 902.

⁸⁷ 283 Cal.Rptr.3d at 887, 894, 902.

⁸⁸ 283 Cal.Rptr.3d at 889-95.

explained, lest the City “circumvent[] what was intended to be a strict limitation on its authority.”⁸⁹

CaRLA v. City of San Mateo is only one case,⁹⁰ of course, but other actors in California’s legal-political establishment are also embracing the HAA and signaling that they want it to have “a broad effect on the law.”⁹¹ After the trial court in *CaRLA v. San Mateo* struck down the HAA, Attorney General Becerra announced that his office would intervene on appeal.⁹² When the Court of Appeal’s decision came down, new AG Bonta put out a press release trumpeting the big win.⁹³

While *CaRLA v. City of San Mateo* was pending, the Governor requested and the Legislature authorized funding for a new Housing Accountability Unit within the Department of Housing and Community Development.⁹⁴ Fully staffed, the HAU will be a 25-person team that investigates alleged violations of state housing law, sends warning letters to cities, and makes referrals to the AG’s new “housing strike force.”⁹⁵ The HAA is not the only housing law the HAU and the strike force will enforce, but it is the capstone, and the fact that these new enforcement capacities came together in the shadow of *CaRLA v. City of San Mateo* suggests that the HAA is in fact bringing about “a new normative [and] institutional framework for state policy,” one which will “stick[] in the public culture” and have “a broad effect on the law.”⁹⁶

The acid test is now at hand. Two days after San Francisco’s Board of Supervisors stalled the 469 Stevenson St. project – voting to require further environmental study while treating the vote as a project denial⁹⁷ – the director of the state housing department announced that the Housing Accountability Unit had launched an investigation.⁹⁸ Is the HAA super enough to stand up to

⁸⁹ 283 Cal.Rptr.3d at 893-94 (quoting *Ruegg & Ellsworth v. City of Berkeley*, 63 Cal.App.5th 277, 299 (2021)). *Ruegg* is an important case that takes a similar no-deference stance in the context of SB 35, a recently enacted bill that requires cities that are not making adequate progress toward their share of the regional housing target to permit certain projects ministerially. See S.B. 35, 2017–2018 Reg., Leg. Sess. (Cal. 2017); CAL. GOV’T CODE § 65913.4.

⁹⁰ Though *Ruegg & Ellsworth v. City of Berkeley*, *supra* note 89, is similar in spirit.

⁹¹ Eskridge & Ferejohn, *supra* note 5, at 1216.

⁹² Emily Durey, *State Intervenes in San Mateo Housing Case that Could Have Major Implications*, MERCURY NEWS, Jan. 15, 2020.

⁹³ Press Release, *Attorney General Bonta Hails Appellate Court Ruling Upholding Key California Affordable Housing Law*, Sept. 13, 2021, <https://oag.ca.gov/news/press-releases/attorney-general-bonta-hails-appellate-court-ruling-upholding-key-california>.

⁹⁴ Conor Dougherty, *California Housing Is a Crisis Newsom Can Take Into His Own Hands*, N.Y. TIMES, Sept. 16, 2021; Press Release, *Governor Newsom Signs Legislation to Increase Affordable Housing Supply and Strengthen Accountability, Highlights Comprehensive Strategy to Tackle Housing Crisis*, Sept. 28, 2021, <https://www.gov.ca.gov/2021/09/28/governor-newsom-signs-legislation-to-increase-affordable-housing-supply-and-strengthen-accountability-highlights-comprehensive-strategy-to-tackle-housing-crisis/>.

⁹⁵ *What Local Governments Need to Know About the New Housing Accountability Unit*, CALIFORNIA CITY NEWS.ORG, Nov. 4, 2021, <https://www.californiacitynews.org/2021/11/what-local-governments-need-know-about-new-housing-accountability-unit.html>; Press Release, *Attorney General Bonta Launches Housing Strike Force, Announces Convening of Tenant Roundtables Across the State*, Nov. 3, 2021, <https://oag.ca.gov/news/press-releases/attorney-general-bonta-launches-housing-strike-force-announces-convening-tenant>.

⁹⁶ Eskridge & Ferejohn, *supra* note 5, at 1216.

⁹⁷ See *infra* notes 101-114 and accompanying text.

⁹⁸ J.K. Dineen, *State Investigating S.F.’s Decision to Reject Turning Parking Lot into 500 Housing Units*, S.F. CHRONICLE, Oct. 28, 2021.

CEQA? Or will it tumble like its precursor, the Permit Streamlining Act? That is the subject of the next Part.

II. Does the HAA (or anything else) Provide a Remedy CEQA-Laundered Project Denials?

The HAA prevents cities from denying or reducing the density of housing projects, but it doesn't exempt projects from environmental review under CEQA.⁹⁹ CEQA spells out time limits for the completion of environmental reviews, but as Part I explained, those limits have proven illusory in court.¹⁰⁰ So if a city wants to deny a project that the HAA protects, what's to keep the city from laundering the denial, as it were, through CEQA? Can the city keep asking the developer for additional environmental studies until, after squandering years and fortunes, the developer cries uncle and walks away?

That's the million-dollar question raised by our running example, the San Francisco Board of Supervisors' divided vote sustaining a local gadfly's appeal of the 469 Stevenson St. project. Rather than deny the project outright or reduce its density (likely HAA violations), the Board reversed the planning commission's certification of the project's Environmental Impact Report and directed the clerk to prepare findings that the EIR was inadequate.¹⁰¹

Yet in view of what the Supervisors said at the hearing and afterwards, it's pretty clear that the Board's real objective was not to air out and mitigate specific environmental impacts but to nix the project. Most of the Supervisors who voted "No" argued that the project was not affordable enough and would cause gentrification¹⁰² – which is not an environmental impact,¹⁰³ and which is exceedingly unlikely to be caused by the project in any event.¹⁰⁴ Supervisor Mandelman told a

⁹⁹ CAL. GOV'T CODE § 65589.5(e).

¹⁰⁰ See *supra* notes 44-55 and accompanying text.

¹⁰¹ San Francisco Bd. of Supervisors, Meeting Minutes – Draft, Tues, Oct. 26, 2021, https://sfbos.org/sites/default/files/bag102621_minutes.pdf.

¹⁰² Supervisor Walton argued that the new housing would “have a very significant displacement and social economic impact on the Sixth Street corridor.” Joe Kukura, *Supes Shoot Down 27-Story SoMa Residential Tower Over Seismic, Displacement Concerns*, SFIST, Oct. 27, 2021, <https://sfist.com/2021/10/27/supes-shoot-down-27-story-soma-residential-tower-over-earthquake-displacement-concerns/>. Supervisor Preston stated he was “baffled” that the city did not get independent guidance in analyzing impacts of gentrification and displacement. Tim Redmond, *In Dramatic Move, Supes Block Huge Luxury Housing Project in Soma*, 48HILLS, Oct. 27, 2021, <https://48hills.org/2021/10/in-dramatic-move-supes-block-huge-luxury-housing-project-in-soma/> Supervisor Chan commented that it was “interesting” that the Planning Commission did not “broaden its analysis” to include gentrification impacts. *Id.*

¹⁰³ See *Porterville Citizens for Responsible Hillside Dev. v. City of Porterville*, 157 Cal. App. 4th 885, 905–06 (2007) (“Unsubstantiated fears about potential economic effects resulting from a proposed project are not environmental impacts that may be considered under CEQA.”). CEQA focuses on impacts on the “physical environment,” see Cal. Pub. Res. Code § 21065, 4 Cal Code Regs §§ 15060(c)(2), (3), 15378(a), not social impacts. However, one envelope-pushing trial court recently required CEQA analysis of potential “displacement effects” from a university's decision to increase enrollment without providing a commensurate increase in student housing. See *Save Berkeley's Neighborhoods v. Regents of Univ. of Cal.*, No. RG19022887, Alameda Sup. Ct., Aug. 23, 2021; Eric Biber, *CEQA and Socioeconomic Impacts*, LEGAL PLANET, Sept. 24, 2021, <https://legal-planet.org/2021/09/26/ceqa-and-socioeconomic-impacts/>.

¹⁰⁴ The vast majority studies with a plausible strategy for identifying the causal effect of new housing development on nearby rents have found that the effect is negative. For a review, see SHANE PHILLIPS ET AL., RESEARCH ROUNDUP: THE EFFECT OF MARKET-RATE DEVELOPMENT ON NEIGHBORHOOD RENTS (UCLA Lewis Center, Feb. 17, 2021), <https://www.lewis.ucla.edu/research/market-rate-development-impacts/>. Adverse gentrification effects

reporter that he'd "feel very good about this vote" if the site "become[s] a 100% affordable project," but that if "15 years from now it's still a parking lot, then I will not feel good."¹⁰⁵ That's an explanation for a vote to deny, not a vote for further environmental study. Supervisor Melgar said the problem was that the developer hadn't "negotiated a deal" with TODCO, a politically powerful nonprofit.¹⁰⁶ That of course has no bearing on the adequacy of the EIR.

The supervisors who voted "No" also knotted themselves up with self-contradictory objections. For example, Ronen and Mandelman stressed that the developer didn't have financing and that the project probably wasn't economically viable (the implication being: "don't blame us for blocking housing"),¹⁰⁷ yet they also demanded that the developer reserve more units for low-income households¹⁰⁸ – which would make the project even more difficult to finance.

The representative who came closest to voicing an environmental objection was Supervisor Ronen, who expressed concern that the project's foundation might be inadequate.¹⁰⁹ She pointed to another downtown project, the Millennium Tower, that had required an expensive retrofit, and she argued that the EIR for Stevenson St. should have fleshed out the seismic issues in detail.¹¹⁰ (The Initial Study treated these issues as "insignificant" because they're addressed by the building code and an engineering peer-review required of all large buildings.¹¹¹ Accordingly, the EIR did not further address them.¹¹²) However, no one put any evidence in the record suggesting that a code-compliant, peer-reviewed project on the site would be an earthquake hazard to people or buildings nearby. Nor, as best we can tell, had Ronen or any other supervisor objected to previous EIRs that treated seismic impacts as adequately addressed through the building code and engineering peer review. In any case, contrary to Ronen's claims to the press, the impact of an earthquake on the proposed building is not an "environmental impact" under CEQA.¹¹³

near the 469 Stevenson project are particularly unlikely because the low-income residents nearby live in protected single-room occupancy hotels, subsidized housing projects, and rent-controlled apartments. See Randy Shaw, *What Drives SF's Gentrification? It's Not What Many Think*, BEYONDCHRON, Nov. 2, 2021, <https://beyondchron.org/what-drives-gentrification-its-not-what-many-think/>.

¹⁰⁵ Heather Knight, *S.F.'s Real Housing Crisis: Supervisors Who Took a Wrecking Ball to Plans for 800 Units*, S.F. CHRONICLE, Oct. 30, 2021, <https://www.sfchronicle.com/sf/bayarea/heatherknight/article/S-F-supervisors-complain-about-our-housing-16576412.php>.

¹⁰⁶ *Id.*

¹⁰⁷ <https://twitter.com/HillaryRonen/status/1455214820454637570>;
<https://twitter.com/RafaelMandelman/status/1455285482468691968>.

¹⁰⁸ See Twitter threads cited in note 107, *supra*.

¹⁰⁹ J.K. Dineen, *State Investigating S.F.'s Decision to Reject Turning Parking Lot into 500 Housing Units*, S.F. CHRONICLE, Oct. 28, 2021.

¹¹⁰ *Id.*

¹¹¹ S.F. Planning Dep't. Notice of Preparation of Environmental Impact Report 185-88, Case No. 2017-014833ENV, Oct. 2, 2019, https://sfplanning.org/environmental-review-documents?field_environmental_review_categ_target_id=212&page=2&order=title&sort=asc.

¹¹² S.F. Planning Dep't, Draft Environmental Impact Report, 469 Stevenson St. Project, Case No. 2017-014833ENV, available at https://sfplanning.org/environmental-review-documents?field_environmental_review_categ_target_id=212&page=2&order=title&sort=asc.

¹¹³ See Dineen, *supra* note 109 (quoting Supervisor Ronen). CEQA requires analysis of the impact of the building on the environment, not the environment on the building. See *Cal. Bldg. Industry Ass'n v. Bay Area Air Quality Mgmt. Dist.*, 362 P.2d 792, 803 (Cal. 2015) (holding that CEQA Guideline which provided that "an EIR on a subdivision astride an active fault line should identify as a significant effect the seismic hazard to future occupants of the subdivision," was "clearly erroneous and unauthorized under CEQA").

All of this suggests that the seismic safety issue – the only plausibly legitimate justification for the Board’s decision to reverse the CEQA certification¹¹⁴ – was pretextual. It was a fig leaf to cover up what the Board intended but was not allowed by law to do: to disapprove the project because it’s too big or not affordable enough.

A. Capitalizing on Administrative Law’s Achilles Heel

The strategy of laundering project denials through CEQA is nothing if not clever, for it takes advantage of two soft spots in administrative law: agency delay and agency bad faith.

1. Delay

The Board of Supervisors’ vote to reverse certification of the Stevenson St. EIR was tantamount to saying, “We haven’t made up our mind about this project, and we need more information before we can make up our mind.” When agencies say they need more time to gather information and make up their mind, courts normally let them have it.¹¹⁵ If an antsy plaintiff sues, the court will say that the suit is premature because there’s not yet a “final” agency decision, or because the plaintiff hasn’t “exhausted her administrative remedies,” or because the case isn’t yet “ripe.”¹¹⁶ After all, it would be a waste of judicial resources and a big practical problem for governance if anyone waiting in line for an agency decision could ask a judge to let her jump the queue.¹¹⁷

¹¹⁴ To be clear, this justification would be legitimate only if there were a “fair argument” that the building itself may cause significant damage to the physical environment in the vicinity of the site, in the event of an earthquake. *Cf.* California Bldg. Indus. Assn. v. Bay Area Air Quality Mgmt. Dist., 362 P.3d 792, 802 (Cal. 2015) (holding that CEQA analysis should consider “exacerbating effect” of new construction on existing environmental hazards, but not the effect of the hazard on the new construction or its occupants).

¹¹⁵ We have found only one case in which a court reviewed a city’s demand for more information in the context of a CEQA review: *Oro Fino Gold Mining Corp. v. Cty. of El Dorado*, 225 Cal. App. 3d 872, 274 Cal. Rptr. 720 (Ct. App. 1990). The Planning Commission and the County Board of Supervisors voted to require an EIR for the mining company’s application for an exploration permit, rejecting the planning staff’s recommendation of a mitigated negative declaration. *Id.* at 876-77. The mining company challenged the decision to require an EIR, and the court reached the merits (sustaining the city’s decision) without addressing finality or exhaustion of administrative remedies. *Id.* at 880-85. By contrast, in *Schellinger Bros. v. City of Sebastopol*, 179 Cal. App. 4th 1245, 102 Cal. Rptr. 3d 394 (2009), the trial court held that courts don’t “have the authority to review the appropriateness of” a city’s decision to require additional environmental study and another round of public comment subsequent following circulation of an initial EIR. *Id.* at 1256. As noted previously, the Court of Appeal sustained the trial court’s decision on other grounds (laches), without addressing the trial court’s holding on reviewability.

¹¹⁶ *See, e.g.,* AIDS Healthcare Found. v. State Dep’t of Health Care Servs., 241 Cal. App. 4th 1327, 194 Cal. Rptr. 3d 425 (2015) (holding that decision of administrative agency reversing order of ALJ and remanding for additional proceedings before the ALJ is unreviewable).

¹¹⁷ The exhaustion doctrine is “principally grounded on concerns favoring administrative autonomy (i.e., courts should not interfere with an agency determination until the agency has reached a final decision) and judicial efficiency (i.e., overworked courts should decline to intervene in an administrative dispute unless absolutely necessary).” *Farmers Ins. Exch. v. Superior Ct.*, 826 P.2d 730, 739 (Cal. 1992). California courts often treat these three doctrines -- exhaustion, finality, and ripeness -- as more or less interchangeable. *See, e.g.,* California Water Impact Network v. Newhall Cty. Water Dist., 161 Cal. App. 4th 1464, 1489 (2008) (describing exhaustion as “closely related” to finality); *O.W.L. Found. v. City of Rohnert Park*, 168 Cal. App. 4th 568, 584 (2008) (stating that finality is an “outgrowth” of ripeness). *See also* *Ticor Title Ins. Co. v. F.T.C.*, 814 F.2d 731 (D.C. Cir. 1987), in

The legal doctrines that prevent plaintiffs from attacking agency delay have exceptions, but the exceptions are very narrow. For example, California courts excuse plaintiffs from exhaustion when further agency proceedings would be “futile” – but only if the plaintiff can “positively state” what the agency has decided (thus rendering further proceedings pointless).¹¹⁸ The courts have also waived exhaustion when the agency has no legal authority to conduct the proceeding at issue,¹¹⁹ and when pursuit of further proceedings would result in irreparable harm.”¹²⁰ None of these exceptions fits the Stevenson St. scenario. The Board of Supervisors carefully avoided “positively stating” its decision; there’s no question that the Board is authorized by law to be the city’s ultimate decider about the CEQA review; and the irreparable harm” exception is “applied rarely and only in the clearest of cases.”¹²¹

It’s also true that if the Legislature prescribes clear-cut timelines for an agency decision, a plaintiff can, in theory, use “traditional mandamus” to get a court order requiring the agency to act.¹²² But as we illustrated in Part I’s discussion of *Schellinger* and the CEQA timelines, these cases make courts uncomfortable.¹²³ At most, a court will order the agency *to make a decision*, as opposed to telling the agency *what to decide*.¹²⁴ And if there’s an available equitable doctrine like laches that would let the agency off the hook, the courts will gladly invoke it.

2. Bad Faith

The other formidable barrier to a judicial fix for CEQA-launched project denials is the principle that courts should review agency decisions solely on the basis of the reasons stated by the agency at the time of the decision, rather than probing to figure out the agency’s real reason and setting the decision aside if the real reason was not authorized by law.

which the three judges each issued their own opinion explaining why the case was untimely, relying on the same facts and normative considerations but using different doctrinal labels: exhaustion per Judge Edwards, finality per Judge Williams, and ripeness per Judge Green.

¹¹⁸ *Jonathan Neil & Assoc., Inc. v. Jones*, 94 P.3d 1055, 1067 (Cal. 2004) (quoting *Sea & Sage Audubon Soc’y, Inc. v. Plan. Com.*, 668 P.2d 664, 667 (Cal. 1983)).

¹¹⁹ *Coachella Valley Mosquito & Vector Control Dist. v. California Pub. Emp. Rels. Bd.*, 112 P.3d 623, 629 (Cal. 2005) (noting that the exception turns on a three-factor test involving “[1] the injury or burden that exhaustion will impose, [2] the strength of the legal argument that the agency lacks jurisdiction, and [3] the extent to which administrative expertise may aid in resolving the jurisdictional issue”).

¹²⁰ *Kaiser Found. Hosps. v. Superior Ct.*, 128 Cal. App. 4th 85, 105 (2005).

¹²¹ *City & Cty. of San Francisco v. Int’l Union of Operating Engineers*, Loc. 39, 151 Cal. App. 4th 938, 948 (2007).

¹²² CAL. CIV. PROC. CODE § 1085(a) (authorizing a writ of mandate “to compel the performance of an act which the law specially enjoins”); e.g., *Sunset Drive Corp. v. City of Redlands*, 73 Cal. App. 4th 215, 221 (1999) (holding that, under section 1085, a court may compel a city to make its decision in the time period required under CEQA); see also *Norton v. S. Utah Wilderness All.*, 542 U.S. 55, 65 (2004) (explaining that, under the federal APA, “when an agency is compelled by law to act within a certain time period, but the manner of its action is left to the agency’s discretion, a court can compel the agency to act, but has no power to specify what the action must be”).

¹²³ See *supra* text accompanying notes 54-55.

¹²⁴ *Schellinger Bros.*, 179 Cal. App. 4th at 1265 (noting that a section 1085 (traditional mandamus) remedy “issues to compel the performance of a ministerial duty, and even then it will not compel the exercise of such a duty in a particular fashion”).

To the extent that the Board’s decision to require further CEQA study of the 469 Stevenson project is reviewable at all, a court would normally uphold the decision so long as the “findings” prepared by the clerk include *some* legitimate reason for additional CEQA study.¹²⁵ The stated rationale must also draw some support from the record of materials before the Board, but the evidentiary demand is lax.¹²⁶ If a reasonable person could agree with the Board’s decision in light of the evidence in the record, courts generally will accept it.¹²⁷

In federal administrative law, there is a narrow exception to these general precepts. Upon a “strong showing of bad faith,” a court may peer behind the agency’s rationale and the record of contemporaneous materials the agency assembled to justify it.¹²⁸ If the court concludes from this investigation that the agency’s stated reasons were pretextual, the court may set aside the agency’s decision – even if the stated reasons (if real) would have sufficed to justify it. This obscure doctrine enjoyed a moment of renaissance when Chief Justice Roberts invoked it to invalidate the Trump Administration’s addition of a citizenship question to the U.S. Census. But even as the Chief Justice insisted that courts “are ‘not required to exhibit a naivete from which ordinary citizens are free,’”¹²⁹ he was at pains to limit the bad-faith exception. The Census dispute was not “a typical case in which an agency may have both stated and unstated reasons for a decision,” but rather the “rare” one in which the agency’s “sole stated reason” “seems to have been contrived.”¹³⁰

It is for very good reasons that the bad-faith exception is very narrow. Much like aggressive judicial review of agency delay, courtroom trials focused on the “real reasons” for agency action would gum up the work of government.¹³¹ Discovery requests and depositions would divert

¹²⁵ Judicial review in CEQA cases is usually limited to the record of the agency proceeding. *See* KOSTKA & ZISCHKE, *supra* note 16, §§ 23.48 - 23.56; *cf.* MITCHELL E. ABBOTT ET AL., CALIFORNIA ADMINISTRATIVE MANDAMUS § 6.119 (CEB 2021) (“Whether the scope of review is the substantial evidence test or the independent judgment test, the trial court cannot substitute its own findings to cure the agency’s inadequate findings as an alternative to remanding the case to the agency....”) (internal citations omitted). The deferential “substantial evidence” standard governs judicial review of “the agency’s conclusions, findings and determinations, the scope of the EIR’s analysis, the amount or type of information contained in the EIR, the methodology used to assess impacts, and the reliability or accuracy of the data supporting the EIR’s conclusions.” KOSTKA & ZISCHKE, *supra* note 16, § 23.34.

¹²⁶ Nominally, the city’s decision must be supported by “substantial evidence” in the record, but this standard is not demanding. It requires only “enough relevant information and reasonable inferences from this information that a fair argument can be made to support a conclusion, even though other conclusions might also be reached.” 14 CAL CODE REGS § 15384(a). *See also* *Laurel Heights Improvement Ass’n v Regents of Univ. of Cal.*, 47 Cal. 3d 376, 393 (1988); KOSTKA & ZISCHKE, *supra* note 16, § 23.34.

¹²⁷ *See supra* note 126.

¹²⁸ *Citizens to Pres. Overton Park, Inc. v. Volpe*, 401 U.S. 402, 420 (1971) (noting that “inquiry into the mental processes of administrative decisionmakers is usually to be avoided,” but it may be permitted upon “a strong showing of bad faith or improper behavior”); *SEC v. Chenery Corp.*, 318 U.S. 80 (1943) (stating the general rule that agency action may only be upheld on the contemporaneous record).

¹²⁹ *Id.* at 2575 (quoting *United States v. Stanchich*, 550 F.2d 1294, 1300 (2d Cir. 1977)).

¹³⁰ *Dept of Com. v. New York*, 139 S. Ct. 2551, 2575, 204 L. Ed. 2d 978 (2019)

¹³¹ *See* Gavoor & Platt, *Administrative Records After Department of Commerce v. New York*, 72 ADMIN. L. REV. 87, 98 (2020) (predicting that extra-record review in the federal context will “divert resources from agencies’ core missions, compulsorily draw the attention of officers of the United States who should otherwise be engaging in the executive function of running the government, and cause long delays with more bet-the-agency litigation”); *see also* Jennifer Nou, *Census Symposium: A Place for Pretext in Administrative Law?*, SCOTUSBLOG, June 28, 2019,

public officials from their primary charge.¹³² Courts would struggle to disentangle the mix of political and policy-minded considerations that shape agency decisionmaking – especially when the leaders of the agency in question (a city council) are elected officials who inevitably pay attention to politics even when acting in a quasi-judicial capacity (hearing a CEQA appeal).

Finally, it's black-letter law that when an agency messes up, the judicial remedy is to vacate the agency's decision and remand for a do-over.¹³³ Even in the Census case, the Court did not strike the citizenship question from the Census: it just told the Commerce Department to try again.¹³⁴ But what does this achieve if the agency is in bad faith? A court order telling San Francisco's Board of Supervisors to rehear the 469 Stevenson St. CEQA appeal would be an invitation to re-laundry the denial, minus the revealing tweets. The pointlessness of the remedy strongly reinforces the argument for not engaging the pretext question in the first place.¹³⁵

B. But the HAA's a Game Changer, Right?¹³⁶

The foregoing ought to douse any hope one might have about using general legal principles to curtail CEQA-laundered project denials. But when the project getting laundered is a *housing project*, a court must consider the Housing Accountability Act as well. And the HAA gives the general principles of administrative law a real shakeup, reworking some and tossing others in the garbage:¹³⁷

- The HAA expressly authorizes judicial inquiry into bad faith.¹³⁸ “Bad faith” as defined by the Act “includes ... an action that is frivolous or otherwise entirely without merit.”¹³⁹ This means that a court can find bad faith without subpoenas, depositions, or other searching inquiry into the mental processes of city council members. If the denial of a project was objectively frivolous, that's enough.

<https://www.scotusblog.com/2019/06/census-symposium-a-place-for-pretext-in-administrative-law/> (voicing similar concerns).

¹³² *Dep't of Commerce*, 139 S. Ct. at 2583 (Thomas, J., concurring in part and dissenting in part) (predicting that the majority's application of the exception will “enable[] partisans to use the courts to harangue executive officers through depositions, discovery, delay, and distraction”).

¹³³ CEQA codifies this principle. CAL. PUB. RES. CODE § 21168.9(c) (“Nothing in this section authorizes a court to direct any public agency to exercise its discretion in any particular way.”). *See also* KOSTKA & ZISCHKE, *supra* note 16, § 23.125 (“The requirement in Pub Res C § 21168.9(b) that a peremptory writ of mandate specify what action by the agency is necessary to comply with CEQA is limited by the provision in § 21168.9(c) that the statute does not authorize a court to direct any public agency to exercise its discretion in any particular way.”).

¹³⁴ *Dep't of Commerce*, 139 S. Ct. at 2576.

¹³⁵ While the *Department of Commerce* remand resulted in the Census going forward without a citizenship question, this was a happenstance of timing: by the time the Supreme Court's decision came down in June 2019, it was too late for the Census Bureau to redo its decision before the 2020 Census. But where there is no impending deadline, a remand is very unlikely to result in a different outcome.

¹³⁶ *Cf.* Sen. Comm. on Transportation and Housing, analysis of AB 3194, as amended June 20, 2018, p. 3 (describing the HAA's standard for determining whether a project is consistent with local land-use rules as a “game changer”).

¹³⁷ *See* Nestor M. Davidson, *Localist Administrative Law*, 126 Yale L.J. 564, 614 (2017) (arguing that “courts should resist false parallels to higher levels of government, where structural realities may be very different”).

¹³⁸ CAL. GOV'T CODE § 65589.5(1).

¹³⁹ CAL. GOV'T CODE § 65589.5(1).

- In cases where a court finds bad faith, the HAA supplants the traditional do-over remedy. It authorizes courts to order the project approved and to retain jurisdiction to ensure that this order is carried out.¹⁴⁰ (Even if there’s no finding of bad faith, the HAA provides that courts shall issue an order compelling compliance within 60 days and fine the city if it misses the deadline.¹⁴¹)
- The HAA provides at least a partial remedy for delay, by defining “[d]isapprove the housing development project” to include “[f]ail[ing] to comply with the time periods [for project review] specified in [the Permit Streamlining Act].”¹⁴²
- The HAA eliminates judicial deference to local governments on all questions about whether a housing development project complies with applicable standards.¹⁴³

The HAA’s stance is one of extreme distrust toward local governments. In 1982, the Legislature stated that “the excessive cost of the state’s housing supply is partially caused by activities and policies of many local governments that limit the approval of housing.”¹⁴⁴ But as the Legislature noted in 2017, when it strengthened various provisions, “[t]he Legislature’s intent in enacting this section in 1982 . . . has not been fulfilled.”¹⁴⁵ Hence the new policy going forward: “that [the HAA] be interpreted and implemented in a manner to afford the fullest possible weight to the interest of, and the approval and provision of, housing.”¹⁴⁶

But there’s a catch. While the HAA provides a powerful remedy for a bad-faith project denials, it’s only explicit remedy for delay is tied to the Permit Streamlining Act. Yet as noted in Part I, the PSA clock doesn’t start to run until CEQA review has been completed,¹⁴⁷ and another provision of the HAA states that the statute shall not “be construed to relieve [a city] from making ... findings required [by CEQA] or otherwise complying with [CEQA].”¹⁴⁸

¹⁴⁰ CAL. GOV’T CODE § 65589.5(k)(1)(A)(ii).

¹⁴¹ CAL. GOV’T CODE § 65589.5(k)(1)(A)(ii).

¹⁴² CAL. GOV’T CODE § 65589.5(h)(6).

¹⁴³ CAL. GOV’T CODE § 65589.5(f)(4) (“[A] housing development project or emergency shelter shall be deemed consistent, compliant, and in conformity with an applicable plan, program, policy, ordinance, standard, requirement, or other similar provision if there is substantial evidence that would allow a reasonable person to conclude that the housing development project or emergency shelter is consistent, compliant, or in conformity.”); CAL. GOV’T CODE § 65589.5(j)(1) (requiring local government that would disapprove or reduce density of project that is consistent within meaning of (f)(4) to make “written findings supported by a preponderance of the evidence on the record” that the project “would have a ... significant, quantifiable, direct, and unavoidable impact, based on objective, identified written public health or safety standards, policies, or conditions as they existed on the date the application was deemed complete” and that “[t]here is no feasible method to satisfactorily mitigate or avoid the adverse impact ... other than the disapproval of the housing development project or the approval of the project upon the condition that it be developed at a lower density”).

¹⁴⁴ Cal. Stats. 1982 ch. 1438; CAL. GOV’T CODE § 65589.5(a)(1)(B).

¹⁴⁵ S.B. 167, 2017–2018 Reg., Leg. Sess. (Cal. 2017); CAL. GOV’T CODE § 65589.5(a)(2)(K). For an argument that increased interregional competition in contemporary America further justifies state-level legislative efforts to promote regionalism in land use, see Nestor M. Davidson & Sheila R. Foster, *The Mobility Case for Regionalism*, 47 U.C. Davis L. Rev. 63, 69 (2013).

¹⁴⁶ CAL. GOV’T CODE § 65589.5(a)(2)(L).

¹⁴⁷ See *supra* text accompanying notes 50-51.

¹⁴⁸ CAL. GOV’T CODE § 65589.5(e).

How can a court make sense of these conflicting directives? In the rest of this Part, we sketch three possible solutions.

C. Solutions

1. Bad-Faith Delay Through CEQA Reversal as HAA “Disapproval”

A court following the Legislature’s command to “interpret[] and implement[]” the HAA “to afford the fullest possible weight to the interest of ... housing”¹⁴⁹ could hold that a city’s delaying of a project in bad faith amounts to “disapproval” within the meaning of the HAA, at least if the delay occurs through a negative vote on a formal approval the developer needs to reach the finish line.

The HAA’s definition of “disapproval” is broad. It includes “any instance in which a local agency . . . votes on a proposed housing development project application and the application is disapproved, including any required land use approvals or entitlements necessary for the issuance of a building permit.”¹⁵⁰ The certification of an EIR or other CEQA clearance is one of many “approval[s]” or “entitlement[s]” which a developer must obtain before eventually landing a building permit. And it is an approval that a city council reversing a CEQA clearance “votes” to deny.¹⁵¹

The HAA’s remedial provisions imply that the statute may be violated other than by final denial of an application for a project entitlement or building permit. A court that finds a violation “shall issue an order ... compelling compliance with this section within 60 days, including, but not limited to, an order that the local agency take action on the housing development project.”¹⁵² The “but not limited to” proviso suggests that a city may violate the HAA by taking unlawful action (or inaction) on ancillary matters necessary for the project to go forward, and it instructs courts to use their powers flexibly to remedy whatever violations a court finds.

On the other hand, the fact that the HAA doesn’t expressly list “legally inadequate CEQA analysis” as a permissible ground for disapproval of a housing development project suggests that the Legislature may not have thought that a city council’s reversal of a CEQA certification would qualify as a housing-project disapproval.¹⁵³ Were the HAA an ordinary statute, this

¹⁴⁹ CAL. GOV’T CODE § 65589.5(a)(2)(L).

¹⁵⁰ CAL. GOV’T CODE § 65589.5(h)(6) (emphasis added).

¹⁵¹ The same reasoning would apply with equal force to any bad-faith denial of a CEQA clearance, such a decision by a planning commission or city council to deny an exemption or to refuse to certify a negative declaration or environmental impact report.

¹⁵² CAL. GOV’T CODE § 65589.5(k)(1)(A)(ii).

¹⁵³ See CAL. GOV’T CODE 65589.5(j)(1) (stating that a local agency which “proposes to disapprove [an HAA-protected] project or to impose a condition that the project be developed at a lower density” “shall base its decision ... upon written findings supported by a preponderance of the evidence on the record that both of the following conditions exist”: (A) that the project “would have a specific, adverse impact upon the public health or safety unless the project is disapproved or approved upon the condition that the project be developed at a lower density”; and (B) that “[t]here is no feasible method to satisfactorily mitigate or avoid the adverse impact ... other than the disapproval

missing affirmative defense would cut pretty strongly against reading “disapproval” to include even bad-faith reversals of CEQA clearances. But the HAA in its current incarnation is meant to be a super-statute, “interpreted and implemented in a manner to afford the fullest possible weight to the interest of, and the approval and provision of, housing.”¹⁵⁴ This interpretive instruction, together with the parallel legislative finding that local governments have for too long managed to evade the Legislature’s intent to “meaningfully and effectively curb[] [their] capability ... to deny, reduce the density for, or render infeasible housing development projects,”¹⁵⁵ suggests that the Legislature wants courts to read the statute flexibly as may be necessary to countermand evasive local tactics the Legislature did not anticipate.

But a line-drawing problem remains: it can’t be true that every city council vote sustaining a CEQA appeal is a “disapproval” within the meaning of the HAA.¹⁵⁶ Some appeals are meritorious. In other cases, a city council may reasonably believe that an appeal has merit, even if some judges would disagree. At what point does a city council’s reversal of a legally sufficient CEQA clearance become an HAA “disapproval”? The HAA’s remedial provisions point toward an answer: when the CEQA reversal is in bad faith.¹⁵⁷ Like the party to a contract who commits anticipatory breach, the city that denies a CEQA clearance in bad faith signals that it has no intention of performing its legal obligation under state law, namely, to approve the HAA-protected project unless the project violates an objective health or safety standard.¹⁵⁸ That the HAA singles out bad-faith conduct by cities provides a justification for, and a limitation upon, expansive readings of “disapproval.”¹⁵⁹

If a court reads “disapproval” to include bad-faith denial of a CEQA clearance, and finds that San Francisco’s Board of Supervisors pretextually reversed the EIR certification for 469 Stevenson St., the court could order the project approved, because the HAA supplants the conventional do-over remedy in cases where a city has denied a project in bad faith.¹⁶⁰

One might object that this gloss on HAA “disapproval” would “relieve[]” the city of compliance with CEQA.¹⁶¹ Not so. San Francisco’s planning department prepared a full EIR for 469

of the housing development project or the approval of the project upon the condition that it be developed at a lower density”).

¹⁵⁴ S.B. 167, 2017–2018 Reg., Leg. Sess. (Cal. 2017)

¹⁵⁵ CAL. GOV’T CODE § 65589.5(a)(2)(K).

¹⁵⁶ For example, if the CEQA review was legally inadequate, surely a city council’s reversal of the planning commission’s certification of the CEQA review would not constitute a “disapproval” of the project. And even if some judges might consider the CEQA review legally sufficient, a city council that had a good-faith and well-substantiated belief that the review was legally inadequate probably should not be regarded as “disapproving” the project just because the council voted to reverse the CEQA clearance.

¹⁵⁷ CAL. GOV’T CODE § 65589.5(l).

¹⁵⁸ The analogy to anticipatory breach is not exact, because traditionally anticipatory breach is found only if the breach is express or the repudiating party “puts it out of his power to perform so as to make substantial performance of his promise impossible.” *Taylor v. Johnston*, 15 Cal. 3d 130, 137, 539 P.2d 425, 430 (1975).

¹⁵⁹ Note that the HAA’s findings also evince special concern about municipal bad faith. *See, e.g.*, CAL. GOV’T CODE § 65589.5(a)(2)(K) (“The Legislature’s intent in enacting this section in 1982 and in expanding its provisions since then was to ... meaningfully and effectively curb[] the capability of local governments to deny, reduce the density for, or render infeasible housing development projects and emergency shelters. That intent has not been fulfilled.”).

¹⁶⁰ CAL. GOV’T CODE § 65589.5(k)(1)(A)(i).

¹⁶¹ CAL. GOV’T CODE § 65589.5(e).

Stevenson St., which the planning commission certified as complete.¹⁶² So long as the court concludes that the EIR was in fact legally sufficient, an order directing the city to approve the project would do no violence to the HAA's CEQA-savings clause. The court could also allow the Board of Supervisors a brief window of time to decide whether to impose any additional mitigation requirements on the project, in light of the findings of the EIR.¹⁶³ This would honor CEQA's policy that elected officials bear final responsibility for deciding what to do about identified environmental impacts.¹⁶⁴

Another counterargument is that the Board in voting to reverse the EIR certification didn't actually determine whether the project could go forward or what its density would be. It just said it wanted more information. This finality argument would be a strong counter under general administrative law principles. But in taking a practical, real-world approach to "disapproval," the HAA undercuts it. For example, delay beyond the time limits of the Permit Streamlining Act is explicitly an HAA disapproval,¹⁶⁵ even though such delay doesn't entail any *de jure* act or statement of reasons by the city. A formal vote reversing a CEQA clearance looks considerably *more* final and at least has the trappings of an agency action.

It's also worth emphasizing that while the terms "finality" and "exhaustion" connote on-off switches – a decision is either final or not, a plaintiff has either exhausted their administrative remedies or not – finality and exhaustion in the permitting context are always matters of degree. Thus, courts have long treated a city council's vote to deny a development proposal as final enough for judicial review, despite the fact that the developer could return to the city with a different proposal, with more public benefits, which the council *might* find satisfactory. This reflects a practical judgment that requiring developers to suffer two or three rounds of defeat at the city council before gaining access to the courts would strike the wrong balance between conservation of judicial resources and municipal autonomy, on the one hand, and protection for the rights of property owners, on the other.

The HAA tips the balance toward earlier judicial review. It emphasizes that the state's public interest, rather than mere property rights, are at stake when a city thwarts a housing development project. The HAA's judgment about the public interest, and its warning about municipal bad faith, ought to inform judicial thinking about finality and exhaustion in the housing context.

In its first formal letter to San Francisco after starting to investigate the 469 Stevenson St. debacle, the Department of Housing and Community Development signaled support for reading

¹⁶² S.F. Planning Com'n Motions Nos. 20960 & 20961 (July 29, 2021), available at https://sfbos.org/sites/default/files/bag102621_agenda.pdf.

¹⁶³ The HAA specifies that a court which finds a violation "shall issue an order ... compelling compliance with this section within 60 days, including, but not limited to, an order that the local agency take action on the housing development project or emergency shelter." CAL. GOV'T CODE § 65589.5(k)(1)(A)(ii).

¹⁶⁴ See Cal. Pub. Res. Code § 21151(c) (providing that if a nonelected decision-making body of a local lead agency certifies a final EIR, the agency must allow the certification to be appealed to the agency's elected decision-making body, if one exists); 14 CAL. CODE REGS § 15090(b) (same). It might also be argued that a court must give the Board an opportunity to specify further mitigation conditions, in view of the CEQA provision stating, "Nothing in this section authorizes a court to direct any public agency to exercise its discretion in any particular way." CAL. PUB. RES. CODE § 21168.9(c). We disagree. The court order we're contemplating would be an order issued pursuant to the HAA, not pursuant to CEQA, so the limitations on judicial remedial authority under CEQA would not apply to it.

¹⁶⁵ CAL. GOV'T CODE § 65589.5(h)(6)(B).

“HAA disapproval” to include pretextual CEQA-clearance reversals.¹⁶⁶ The Department called the Board of Supervisor’s vote an “effective denial” and asked the city to explain its rationale within 30 days.¹⁶⁷ The letter emphasized, as we do, that disapproval includes “denial of other required land use approvals or entitlements necessary for the issuance of a building permit.”¹⁶⁸ And it noted that, in light of the Board’s “various vague concerns” with the project, it was “unclear what actions these project applicants are required to take to advance these projects.”¹⁶⁹ If an agency that the Legislature has authorized to enforce the HAA concludes that bad-faith denials of CEQA clearances are “disapprovals within the meaning of the HAA,”¹⁷⁰ a court need not go out of its way to conclude the same.

2. Enforcing CEQA Timelines in Light of the HAA

Without reaching the question of whether bad-faith denial of a CEQA clearance is a “disapproval” within the meaning of the HAA, a court could hold that the Legislature’s refashioning of the HAA as a super-statute warrants revisiting – and limiting or rejecting – the Court of Appeal’s decision in *Schellinger Brothers v. City of Sebastopol*.¹⁷¹ Burying *Schellinger* is necessary to give practical effect to the HAA’s incorporation of the Permit Streamlining Act’s timelines into the definition of disapproval.¹⁷²

As we explained in Part I, *Schellinger* held that judges may not order a city to certify an environmental impact report (as opposed to ordering the city to make up its mind about whether to certify it).¹⁷³ The court also said that the project applicant had, by cooperating with the city and making revisions well past CEQA’s deadline, forfeited its right to enforce the deadline.¹⁷⁴

The most basic problem with *Schellinger* is that it makes a hash of the statute’s definition of “disapproval.” As noted, the HAA defines disapproval to include noncompliance with the PSA deadlines, but the PSA clock only starts to run after CEQA review is done.¹⁷⁵ So if there’s no practical way of forcing cities to comply with CEQA’s deadlines, then the delay-oriented piece of the HAA’s definition of disapproval is a dead letter. That doesn’t befit any statute, let alone one which the Legislature has declared to be super.

¹⁶⁶ Letter from Shannan West, Housing Accountability Unit Chief, Dep’t of Hous. & Cmty. Dev., to Kate Conner, LEED AP, Manager, Priority Projects and Process, San Francisco Planning Dep’t, Nov. 22, 2021 (on file with authors).

¹⁶⁷ *Id.* at 1.

¹⁶⁸ *Id.* at 3.

¹⁶⁹ *Id.* at 1-2.

¹⁷⁰ CAL. GOV’T CODE § 65585(j)(1) (authorizing Department to notify the local government and, as appropriate, the Attorney General, when it finds “that any local government has taken an action in violation of [enumerated statutes],” the first of which is the HAA).

¹⁷¹ 179 Cal. App. 4th 1245 (2009).

¹⁷² CAL. GOV’T CODE § 65589.5(h)(6).

¹⁷³ See *supra* text accompanying notes 53-55.

¹⁷⁴ 179 Cal. App. 4th 1245, 1267–70. A future court might distinguish *Schellinger* on the ground that the project proposal at issue morphed considerably during the long period of CEQA review. See *id.* at 1250-53. On the other hand, cities should not be able to evade the CEQA deadlines by pressuring developers into revising their project proposals.

¹⁷⁵ CAL. GOV’T CODE § 65950.

As for *Schellinger*'s laches holding (that the developer who cooperates past a deadline forfeits her right to enforce it), equitable doctrines are not supposed to be used in ways that “nullify an important policy adopted for the benefit of the public.”¹⁷⁶ Whatever might have been said about the HAA when *Schellinger* was decided in 2009, there is no gainsaying that, today, the Act's policy of expeditious permitting is “important” and inures to the “benefit of the public.”¹⁷⁷

CEQA allows one year for completion of an EIR.¹⁷⁸ A recent study of housing project entitlements in twenty California cities found that the median project in San Francisco took 27 months to entitle; only 5% were entitled in under a year.¹⁷⁹ 469 Stevenson St. is more of the same. The project application was submitted on October 3, 2018.¹⁸⁰ The Initial Study, which determined that an EIR was required, was completed almost a year later.¹⁸¹ By statute, however, an Initial Study is supposed to be completed within a *month*, not a *year*.¹⁸² The planning department released its draft EIR for public comment not too long after the Initial Study (Mar. 11, 2020), but the department took ages compiling its response to comments, and the final EIR wasn't certified by the planning commission until July 29, 2021.¹⁸³ This was nearly three years after the developer's submission of the project application. And then came the appeal to the Board of Supervisors, resulting in further delay.

Bearing these facts in mind, and reading CEQA in light of the newly “super” policy of the HAA, a court might reasonably hold (1) that the CEQA deadlines are enforceable by mandamus regardless of whether the developer has cooperated with the city past the deadline (contra *Schellinger*), and (2) that if the CEQA deadline has passed and a legally sufficient environmental review document has been prepared, the city must certify it.

The second holding might seem to depart from the background administrative law norm (which CEQA incorporates) that a court can only order an agency to act, rather than telling it how to

¹⁷⁶ *Golden Gate Water Ski Club v. Cty. of Contra Costa*, 165 Cal. App. 4th 249, 263 (2008) (holding that laches is unavailable for this reason); *Feduniak v. California Coastal Com.*, 148 Cal. App. 4th 1346, 1381 (2007) (same).

¹⁷⁷ The laches holding of *Schellinger* is also suspect on traditional equitable grounds. First, the doctrine of laches is only supposed to penalize plaintiffs who “unreasonabl[y]” delay bringing suit. *Conti v. Bd. of Civ. Serv. Commissioners*, 461 P.2d 617, 622 (Cal. 1969). *Schellinger* failed to ask whether it's reasonable for a developer whose business depends on securing discretionary permits from a city to cooperate with the city's review process well past any statutory deadline (bringing suit only as a last resort). Second, as an equitable doctrine, the laches defense should have no currency when the city acts in bad faith (has “unclean hands”), as San Francisco appears to have done in reversing the EIR certification for 469 Stevenson. *See Prang v. Los Angeles Cty. Assessment Appeals Bd. No. 2*, 54 Cal. App. 5th 1, 18 (2020) (“Factually, laches, as an equitable doctrine, is not available to a party with unclean hands.”).

¹⁷⁸ CAL. PUB. RES. CODE § 21151.5(a).

¹⁷⁹ Moira K. O'Neill et al., *Examining Entitlement in California to Inform Policy and Process: Advancing Social Equity in Housing Development Patterns* 93 (Nov. 8, 2021), https://papers.ssrn.com/sol3/papers.cfm?abstract_id=3956250.

¹⁸⁰ San Francisco Planning Com'n Motion No. 20961 (hearing date: July 29, 2021).

¹⁸¹ Notice of Preparation of Environmental Impact Report, Case No. 2017-014833ENV, San Francisco Planning Department, Oct. 2, 2019.

¹⁸² CAL. PUB. RES. CODE §§ 21080.1, 21080.2 (requiring lead agency to make “final” determination of whether to prepare an environmental impact report, negative declaration, or mitigated negative declaration within 30 days of project application being determined to be or deemed complete).

¹⁸³ S.F. Planning Com'n Motions Nos. 20960 & 20961 (July 29, 2021), available at https://sfbos.org/sites/default/files/bag102621_agenda.pdf.

act.¹⁸⁴ But sometimes only one course of action is available to the agency, in which case a court may direct the agency to do what the law requires it to do.¹⁸⁵ What we're proposing is that courts read the CEQA deadlines, in light of the HAA, as creating a ministerial duty to certify any legally sufficient environmental review document once the deadline for completing CEQA review has passed.¹⁸⁶

The courts could also give cities a brief window to decide what changes to the project or other mitigation should be required in view of the environmental study. This splitting of the baby – letting the politicians choose mitigation but not legally unnecessary environmental study past the CEQA deadline – would go a good distance toward reconciling CEQA with the HAA. It would breathe some life into the PSA deadlines (which the HAA incorporates into its definition of disapproval¹⁸⁷) without impinging on municipal authority to impose mitigation conditions on development approvals (which the HAA countenances so long as they don't reduce the project's density¹⁸⁸).

3. Levering “Pretext” for Judicial Review of CEQA-Clearance Denials

Our third solution is inspired by Chief Justice Roberts's opinion in *Department of Commerce v. New York*.¹⁸⁹ Instead of putting an expansive gloss on HAA “disapproval,” or battling *Schellinger* to make the CEQA deadlines judicially enforceable, a court would hold that city council or planning commission's vote to deny a CEQA clearance is reviewable for pretext in limited circumstances.¹⁹⁰ Specifically, a plaintiff's “strong showing of bad faith” would render the decision to require further environmental study reviewable (notwithstanding the usual exhaustion requirement), and, if the court determines that the city acted in bad faith, the court would hold the city's decision unlawful.

¹⁸⁴ CEQA's remedial provisions authorize courts to order “specific action as may be necessary to bring the [an agency] decision into compliance with” the statute, CAL. PUB. RES. CODE § 21168.9(a)(1), (3), but also declare, “Nothing in this section authorizes a court to direct any public agency to exercise its discretion in any particular way,” CAL. PUB. RES. CODE § 21168.9(c).

¹⁸⁵ *Berkeley Hillside Pres. v. City of Berkeley*, 60 Cal. 4th 1086, 1122, 343 P.3d 834, 858 (2015), as modified (May 27, 2015) (stating that lower court on remand “may order preparation of an EIR only if, under the circumstances, the City would lack discretion to apply [an] exemption or to issue a negative declaration”).

¹⁸⁶ A possible counterargument might be that this would only incentivize an anti-housing city council to put maximal pressure on the planning department so that it rejects the EIR of any large housing project in the first instance. That way, a city would avoid ever having a “legally sufficient EIR” for the court to order the city to approve. However, this work-around might be difficult. Because the developer is paying for the EIR and hiring the consultants, a planning department will have trouble disguising unusually slow processing, and it cannot altogether refuse to consider a complete EIR. Yet, at least in some cities, there is still probably some risk of political pressure down the chain. Cf. David J. Barron, *From Takeover to Merger: Reforming Administrative Law in an Age of Agency Polarization*, 76 GEO. WASH. L. REV. 1095, 1096 (2008) (noting that, in the federal context, agency officials often want to align their actions with the preferences of their political overseers).

¹⁸⁷ CAL. GOV'T CODE § 65589.5(h)(6).

¹⁸⁸ CAL. GOV'T CODE § 65589.5(j)(1).

¹⁸⁹ 139 S.Ct. 2551 (2019).

¹⁹⁰ By “vote to deny a CEQA clearance,” we mean an official determination that a project is not entitled, at the time of the decision, to the CEQA approval sought by the developer. This would include a vote to deny a CEQA exemption, a vote to require an EIR instead of approving the negative declaration sought by the developer, a vote against certifying an EIR, or, as in the case of the Stevenson St. project in San Francisco, a vote to reverse a certification of an EIR.

This solution invites a number of questions. First, is it even available in California? Second, once the door has been opened to pretext inquiries in this context, what's to keep them from spreading across all of state administrative law, at a high cost to courts and agencies alike?¹⁹¹

Third, would this solution be meaningful as a practical matter, given that the standard judicial remedy in CEQA cases is a remand for a do-over – which is basically an invitation for the bad-faith agency to better cover its tracks?

As to the first question: The solution is available in the sense that it hasn't been ruled out by California Supreme Court. Although there's a pretty strong norm against looking behind the official record assembled by an agency, the Court has reserved the question of whether there might be a "limited" exception for "agency misconduct."¹⁹² The Court has also allowed extra-record evidence in challenges to "ministerial or informal administrative actions," on the theory that they merit less deference.¹⁹³

The second question – whether pretext claims can be cabined – is serious¹⁹⁴ but not hard to answer. The HAA and the institutions now being erected to enforce it offer guardrails. In light of the HAA's skepticism about municipal good faith, a court could hold that "CEQA pretext" claims are only available if the environmental clearance concerns an HAA-protected project. Or, going a step further, a court could hold that pretext claims are available only if HCD or the Attorney General makes the preliminary "strong showing of bad faith," or otherwise raises serious concerns about the city's development-review processes.¹⁹⁵ This would limit pretext litigation to cases where a coordinate branch of state government has balanced the benefits and costs and deemed the inquiry worthwhile.

The remedy question concerns us more.¹⁹⁶ If a court finds that a city's CEQA reversal was pretextual, must it send the whole thing back and give the city another chance to dress up its decision, exactly as the U.S. Supreme Court did with the Census case? Not necessarily. The California Supreme Court has endorsed the "inherent power" of a trial court to send only *part* of a decision back to the agency, while retaining jurisdiction to issue judgment later.¹⁹⁷ Perhaps a court in a pretext case could treat a CEQA certification as mostly complete (and valid), retain

¹⁹¹ See sources cited in note 131, *supra*.

¹⁹² *Western States Petroleum Ass'n v. Superior Court*, 888 P.2d 1268, 1276 n.5 (Cal. 1995); *see id.* at 1278 (leaving open the possibility that such evidence may be admissible "under unusual circumstances or for very limited purposes not presented in the case now before us").

¹⁹³ *Id.* at 1277; *see* Michael Asimow, *The Scope of Judicial Review of Decisions of California Administrative Agencies*, 42 UCLA L. Rev. 1157, 1234-37 (1995) (discussing and critiquing the use of an "open record" in these cases).

¹⁹⁴ *See supra* Part II.A (discussing reasons why courts generally abjure inquiry into pretext).

¹⁹⁵ *Cf.* Letter from Shannan West, Housing Accountability Unit Chief, Dep't of Hous. & Cmty. Dev., to Kate Conner, LEED AP, Manager, Priority Projects and Process, San Francisco Planning Dep't, Nov. 22, 2021 (on file with authors) (concluding, "HCD is concerned specifically that the Stevenson Project and O'Farrell Project that have been effectively denied without written findings as well as larger trends in the City/County's review of housing") (emphasis added).

¹⁹⁶ *See supra* text accompanying notes 133-135.

¹⁹⁷ *Voices of the Wetlands v. State Water Res. Control Bd.*, 257 P.3d 81, 98-99 (Cal. 2011) (stating that administrative mandamus "impose[s] no absolute bar on the use of prejudgment limited remand procedures such as the one employed here").

jurisdiction, and give the city a short period of time to address any legitimate concerns identified by the court on a limited remand. This would light a fire under the city and ensure that the case comes back to the same judge.¹⁹⁸

As motivation for this or another nonstandard remedy, consider what courts do when a decision-maker is found to have prejudged the facts or otherwise manifested bias in violation of due process. Normally the court disqualifies the biased arbiter and remands for a fair hearing before another hearing officer. The Court of Appeal has said that a city's "malicious[] or arbitrar[y]" refusal to certify a CEQA document violates the developer's right to due process.¹⁹⁹ If that's right, a city council's bad-faith reversal of a CEQA certification violates due process too, and the biased decision-maker should be disqualified on remand. If just a few councilmembers were found to be biased, a court could disqualify them and remand for a do-over by the rest of the council (if a quorum remains).²⁰⁰ But a court generally cannot disqualify the whole decision-making body that must decide the case (as is true under CEQA), so there is no analogous remedy if a quorum of the council has shown bad faith.²⁰¹ Hence the need for innovation beyond the usual do-over remedy.²⁰²

Yet the judicial norm against telling agencies what they must do is very strong, and without specific textual authorization – e.g., the HAA directing courts to order projects approved, or CEQA specifying deadlines for completion of environmental review – we fear that judges would be reluctant to deviate from the standard remedy, even in a pretext case.

One more point about remedies is worth mentioning. A bad-faith CEQA reversal that violates due process would make the city liable for damages.²⁰³ The prospect of having to compensate a developer for holding costs, and for the expense of the additional environmental studies, might be enough to discourage some cities from trying to launder housing denials through CEQA.

* * *

¹⁹⁸ Although the traditional remedy is to give the city another chance to rationalize its pretextual decision to require further environmental studies, the administrative mandamus statute also allows a court to order a city to "take such further action as is specially enjoined upon it by law." CAL. CIV. PROC. CODE § 1094.5(f). This provision therefore may authorize a stronger remedy, when read in light of the HAA's definition of disapproval or the synergism of PSA and the CEQA time limits.

¹⁹⁹ *Sunset Drive Corp. v. City of Redlands*, 73 Cal. App. 4th 215, 225, 86 Cal. Rptr. 2d 209, 217 (1999).

²⁰⁰ *Nasha v. City of Los Angeles*, 125 Cal. App. 4th 470, 484, 22 Cal. Rptr. 3d 772, 781 (2004) (vacating a decision where the outcome was determined by the vote of a council member who was not a "reasonably impartial, noninvolved reviewer").

²⁰¹ *Caminetti v. Pac. Mut. Life Ins. Co. of Cal.*, 139 P.2d 908, 920 (1943). But in at least one case, this rule did not apply where there was a legally sufficient underlying decision that the court could let stand. *See Mennig v. City Council*, 86 Cal. App. 3d 341, 351–52 (1978) (disqualifying the city council because it was "embroiled" in the dispute and letting stand the civil service commission's earlier decision).

²⁰² Consider the following thought experiment: what if a court, after concluding that an entire city council must be disqualified, remanded to a *different* city council? For example, what if the court disqualified the San Francisco Board of Supervisors from certifying the EIR as to 469 Stevenson St. and remanded to the Oakland City Council? (No doubt Oakland would have considerably less hesitation in helpfully approving a legally sufficient EIR on behalf its neighbor...while also getting to bill its time!). This solution strikes us as promising, but it would probably require explicit legislative authorization.

²⁰³ 73 Cal. App. 4th 215, 225, 86 Cal. Rptr. 2d 209, 217 (1999).

After a forty-year saga, the HAA is at a moment of truth. Will courts nodding to background principles of administrative law stand by while city councils deny 500-home projects on frivolous environmental grounds? Or will courts wake up to the HAA's ditching of the old ways and appreciate – finally – that housing is the rare domain in which city councils are not to be trusted at all?

III. Calibrating Environmental Review to the Scope of Municipal Discretion Under the HAA

CEQA requires state and local agencies that have discretion to choose among possible options to study environmental effects before making their choice.²⁰⁴ In theory, this leads to better agency decisions.²⁰⁵ But when other laws require an agency to select a particular option, CEQA doesn't apply.²⁰⁶ There's no reason to write a detailed list of the pros and cons of different options if you know from the start exactly which choice you have to make.

When a developer submits a housing proposal, the HAA substantially limits the choices open to the city. So you would think that review under CEQA would be limited accordingly. You would, unfortunately, be wrong – at least as a description of current practice.²⁰⁷

So it is that a proposal to build 500 apartments on a downtown San Francisco parking lot, a block from the subway, in a designated “priority development area” under the region's climate plan, ended up mired for years in the most extensive and costly form of environmental review required by CEQA: the Environmental Impact Report (EIR).

And why? Because San Francisco's planning department had concluded, on the basis of a 342-page Initial Study, that a “fair argument” could be made that the Stevenson St. project may have a significant local environmental impact in the form of shadows, wind, or (during construction) noise and air pollution.²⁰⁸ The Initial Study evaluated the project's potential impact relative to current environmental conditions nearby.²⁰⁹ It did not ask whether the project would have a significant marginal impact, relative to any other project of the size that the HAA entitles the developer to build on the site.

If the Stevenson St. project's marginal impact would be close to nil (as we think likely), then the EIR was an environmentally pointless exercise. Its real function, apparently, was to give local activists and city officials a way to tie up the project until the developer either walked away or paid off the politically connected nonprofit that led the charge against it.²¹⁰

²⁰⁴ CAL. PUB. RES. CODE § 21080(a) (CEQA applies to “discretionary projects proposed to be carried out or approved by public agencies”).

²⁰⁵ A contestable claim – but that's for another day.

²⁰⁶ KOSTKA & ZISCHKE, *supra* note 16, §§ 4.24 - 4.26A.

²⁰⁷ See *infra* notes 208-210 and 222 (explaining course of environmental review for Stevenson St. project in San Francisco). Discussions with leading CEQA practitioners have persuaded us that the Stevenson Street project's EIR is representative of current practice.

²⁰⁸ Notice of Preparation of Environmental Impact Report, Case No. 2017-014833ENV, San Francisco Planning Department, Oct. 2, 2019.

²⁰⁹ *Id.* at 2-3, 73-218.

²¹⁰ See Heather K. Knight, *S.F.'s Real Housing Crisis: Supervisors Who Took a Wrecking Ball to Plans for 800 Units*, S.F. CHRONICLE, Oct. 30, 2021 (quoting one supervisor who said he'd “feel very good about this vote” if the project site becomes “a 100% affordable housing project,” and another who complained that the developer hadn't struck a deal with a local nonprofit, TODCO); J.K. Dineen, *'You Don't Mess with Him': How an S.F. Housing Advocate Wields Power by Funding Ballot Measures*, S.F. CHRONICLE, Nov. 18, 2021 (profiling the head of TODCO).

The argument of this Part is that the scope of CEQA review of housing development projects should be tailored to the scope of municipal discretion. A housing project should require an EIR only if the city exercises discretion to shape the project in some way that generates a significant marginal impact, relative to what the HAA compels the city to approve.²¹¹

Our approach would not “relieve local governments from complying with” CEQA.²¹² But it would require overturning or significantly limiting several judicial precedents that have been incorporated into the official CEQA Guidelines.²¹³ As such, our proposal poses a stark test of whether the HAA really is a super-statute, one which “sticks in the public culture” and exerts “a broad effect on the law.”²¹⁴ If courts and the gubernatorial appointees responsible for the CEQA Guidelines get behind our approach, then the HAA will in fact “meaningfully and effectively curb[] the capability of local governments” to hobble housing development projects.²¹⁵ If they do not, there can be little doubt that NIMBY cities will become ever more expert at exploiting CEQA to undermine the HAA.

A. “Effect” Relative to What?

We begin with an elementary point about causation. It is senseless to try to characterize the environmental effect of a proposed housing project without comparing it to some alternative use of the site. Consider an analogy: What is the effect of a new drug or medical device? The answer depends on what you’re comparing it to. Relative to a placebo, the effect of the new drug may be large. Compared to the best treatment currently in use, the effect of the very same drug could be small or even negative.²¹⁶

The same goes for housing projects. They have effects only when they’re compared to some alternative. Let’s call the point of comparison the reference alternative. What is conventionally labeled “the baseline” in an environmental impacts study is, properly understood, a compound of two things: an alternative use of the site (the “reference alternative”) and a projection of environmental conditions in and around the site conditional on that use of it.

CEQA analyses, relying on CEQA caselaw, usually elide this fundamental point. By convention, they purport to measure the “effect” of a project relative to “current environmental conditions” on the site and in its vicinity.²¹⁷ This is a misleading point of reference if current environmental conditions would change absent the project. No medical researcher would measure the “effect”

²¹¹ CEQA is not an independent source of municipal discretion. CAL. PUB. RES. CODE § 21004 (“In mitigating or avoiding a significant effect of a project on the environment, a public agency may exercise only those express or implied powers provided by law other than this division.”).

²¹² CAL. GOV’T CODE § 65589.5(e).

²¹³ See *infra* notes 238-244 and accompanying text.

²¹⁴ Eskridge & Ferejohn, *supra* note 5, at 1216.

²¹⁵ CAL. GOV’T CODE § 65589.5(a)(2)(K).

²¹⁶ These points follow from what is now called the “potential outcomes” framework for causal inference. See generally Donald B. Rubin, *Causal Inference Using Potential Outcomes: Design, Modeling, Decisions*, 100 J. AM. STATISTICAL ASS’N 322 (2005).

²¹⁷ See generally KOSTKA & ZISCHKE, *supra* note 16, §§ 12.16 - 12.20 (summarizing CEQA caselaw and guidelines about baselines).

of an experimental treatment by comparing the health status several years in the future of elderly patients who received the treatment with their health at the time the treatment was administered. That comparison would obscure the effect of the treatment, because old people tend to decline as they age.

The CEQA analyst's conceptual mistake about baselines is not a problem in contexts where the permitting agency has authority to deny the project and doing so would maintain current environmental conditions. In such circumstances, the current-environmental-conditions baseline is equivalent to treating the "no-action alternative" as the reference alternative. This is like a placebo reference condition in a drug trial.

But the current-environmental-conditions baseline is nonsensical when the public decisionmaker lacks legal authority to maintain it. This is precisely the situation that cities face when developers propose HAA-protected housing projects. Cities may place discretionary conditions of approval on such projects, but they may not deny the project or reduce its density.²¹⁸ Accordingly, the environmental impact of the project should be gauged relative to a reference-alternative project of the scale the city is required by law to approve.

B. An HAA-Informed Protocol for CEQA Review of Housing Projects

The first step in CEQA review is preparation of the Initial Study, which seeks to determine whether there is a "fair argument" that the proposed project "may" have a significant impact on the environment.²¹⁹ If the answer is "Yes," then the project proponent must pay for an EIR that fully analyzes the potential effects identified in the Initial Study.²²⁰

The policies of the HAA and the policies of CEQA can be reconciled, to some extent, by asking the threshold HAA question at the outset of the Initial Study: Does the project as proposed comply with applicable, objective general plan, zoning and development standards, as defined in the HAA?²²¹ If it does, the city may deny or downsize the project only if it violates a written, objective health or safety standard within the meaning of the HAA. So for zoning-compliant projects, the Initial Study should gather information about potential health / safety violations and determine whether a preponderance of the evidence establishes a violation. A conventional CEQA review is in order only if such a violation is established (because the city may deny the project).

²¹⁸ CAL. GOV'T CODE § 65589.5(j)(1). Again, CEQA is not an independent source of discretion—"a public agency may exercise only those express or implied powers provided by law other than this division." CAL. PUB. RES. CODE § 21004.

²¹⁹ KOSTKA & ZISCHKE, *supra* note 16, §§ 6.1 - 6.80.

²²⁰ KOSTKA & ZISCHKE, *supra* note 16, §§ 6.4, 6.37 - 6.59.

²²¹ Cal. Gov't Code 65589.5(f)(4). This inquiry should address only those standards of which the city gave proper notice to the developer of noncompliance, as specified in Cal. Gov't Code 65589.5(j)(2). Note also that if the project qualifies for a density bonus under state law, this will render some local development standards inapplicable. *See generally* JON GOETZ & TOM SAKAI, GUIDE TO THE CALIFORNIA DENSITY BONUS LAW (rev'd Jan. 2021).

For projects that comply with general plan and zoning standards, and that don't violate health or safety standards, it's meaningless to conduct an environmental review that benchmarks the project against a no-action alternative or "current environmental conditions" in the vicinity of the site. The city's discretion is limited to altering the project with conditions of approval that do not reduce its density, and the CEQA baseline should be defined accordingly.

There are two plausible reference alternatives in this circumstance. First, the analysis could proceed using a project-as-proposed benchmark. The reviewer would inventory any discretionary conditions of approval that the city is considering imposing on the project, and then benchmark (1) environmental conditions if the project goes forward with the discretionary condition(s) imposed, against (2) environmental conditions if the project goes forward in the form it was proposed. The difference represents the environmental effect of the city's exercise of discretion.

To illustrate, if the city were considering a discretionary condition of approval that would require rooftop solar panels, and concerns were raised about glare from the panels, the Initial Study would undertake to determine whether there is a fair argument that the rooftop solar condition may cause a significant environmental impact in the form of glare, relative to the scenario in which the city approves the project in the form it was proposed.

Alternatively, the city could posit a green-reference benchmark, measuring the impact of an HAA-protected project relative to a model "green" project of the same density on the same site. The green-reference alternative might be defined as a project that provides the minimum number of on-site parking spaces; that uses low-energy building materials; and that minimizes impermeable ground cover (insofar as the city has authority to impose such conditions). The key point is that the green reference alternative would be a legally available option, and as such represents an informative benchmark against which to compare the proposed project.

Under either model, it would be the rare HAA-protected project that requires an EIR. Cities do not often impose conditions that reduce environmental amenities in the vicinity of a project, so the project-as-proposed benchmark would yield *pro forma* negative declarations in most cases. As for the green-reference benchmark, developers who anticipate opposition from neighbors, unions, or other interest groups would likely conform their proposal to the benchmark. If the project as proposed is HAA-protected and uses the green-reference design, then by construction it would have no environmental effects for CEQA purposes.²²²

²²² Needless to say, the environmental studies prepared for 469 Stevenson project in San Francisco did not hew to these principles. The HAA was nowhere mentioned in the Initial Study. The study did briefly discuss general plan and zoning standards, noting one potential violation, but it did not distinguish objective from subjective standards or explain whether the city had provided the developer with timely written notice of noncompliance. Notice of Preparation of Environmental Impact Report 67-71, Case No. 2017-014833ENV, San Francisco Planning Department, Oct. 2, 2019. Putative effects were assessed relative to current conditions on the site and in the vicinity. *See id.* at 2-3, 59-67, 73-218. Had the analysis proceeded as we recommend, the Initial Study probably would have concluded that no EIR was required, since the city had not proposed (so far as we can tell) any discretionary condition of approval that would damage the environment; since nothing in the Initial Study identified any respects in which the proposed design and materials fell short of any green-design norm; and since the study did not identify an objective, properly noticed general plan or zoning standard, or health or safety standard, that the project arguably violated.

The Initial Study did note that the project relied on waivers of several local development regulations, pursuant to state density bonus law. *Id.* at 67-68. However, the HAA protects projects that rely on state density bonus law. CAL.

C. Does CEQA Allow It?

The idea of tailoring the scope of environmental review to the scope of agency discretion has precedent under statutory analogues to CEQA at the national level and in New York. Review under the National Environmental Policy Act (NEPA) is limited to “effects” that are proximately caused by the agency’s discretionary choices.²²³ Thus, in *U.S. Department of Transportation v. Public Citizen*, the U.S. Supreme Court held that an environmental impact study prepared by the Department in connection with the North American Free Trade Agreement need not analyze pollution resulting from an increase in Mexican truck traffic, because the Department had no legal authority to exclude Mexican trucks.²²⁴ To date, no California court has ruled on whether CEQA incorporates the proximate-causation theory of *Public Citizen*, but California courts do seek guidance from NEPA precedents when tough questions arise under CEQA.²²⁵

In New York, courts got to a similar place by rejecting the “no-build baseline” in cases where the project proponent may build something as of right.²²⁶ Specifically, if a developer proposes an office or residential building that would require rezoning, on a site where a smaller building is allowed as of right, the effect of the proposed project is analyzed relative to the “as-of-right alternative” rather than the “no-build alternative” or “current environmental conditions.”²²⁷ Because the city lacks authority to deny the smaller project, it would be uninformative to conduct an environmental review using a no-project baseline.

Like the National Environmental Policy Act and New York’s State Environmental Quality and Review Act, CEQA exempts “ministerial” permits from environmental review.²²⁸ Discretion is

GOV’T CODE § 65589.5(j)(3) (“For purposes of this section, the receipt of a density bonus pursuant to Section 65915 shall not constitute a valid basis on which to find a proposed housing development project is inconsistent, not in compliance, or not in conformity, with an applicable plan, program, policy, ordinance, standard, requirement, or other similar provision specified in this subdivision.”).

²²³ *U.S. Dep’t of Trans. v. Public Citizen*, 541 U.S. 752, 767 (2004). (“NEPA requires a reasonably close causal relationship between the environmental effect and the alleged cause[, akin] to the familiar doctrine of proximate cause from tort law.”) (internal quotations and citations omitted).

²²⁴ *Id.* at 770 (“We hold that where an agency has no ability to prevent a certain effect due to its limited statutory authority over the relevant actions, the agency cannot be considered a legally relevant ‘cause’ of the effect.... Because the President, not [the agency], could authorize (or not authorize) cross-border operations from Mexican motor carriers, and because [the agency] has no discretion to prevent the entry of Mexican trucks, its [NEPA study] did not need to consider the environmental effects arising from the entry.”).

²²⁵ KOSTKA & ZISCHKE, *supra* note 16, § 22.4 (observing that “NEPA cases continue to play an important role in adjudication of CEQA cases, especially when a concept developed in NEPA decisions has not yet been applied in CEQA cases”) (emphasis added).

²²⁶ MICHAEL B. GERRARD ET AL., ENVIRONMENTAL IMPACT REVIEW IN NEW YORK § 8A.04 (2021).

²²⁷ *Id.*; NYC MAYOR’S OFFICE OF ENV. COORDINATION, CEQR TECHNICAL MANUAL § 2.7 (Nov. 2020), https://www1.nyc.gov/assets/oec/technical-manual/2020_ceqr_technical_manual.pdf (“Sometimes, private applicants state an intention to develop their property in the future, with or without approval of a proposed project.... If the lead agency determines it is reasonable to assume that the applicant’s stated No Action scenario would occur in the future without the proposed project, the scenario would constitute the No-Action scenario for analysis purposes.”).

²²⁸ CAL. PUB. RES. CODE § 21080(b)(1),

always the trigger.²²⁹ However, the Court of Appeal has held in several cases that if a city has any discretion to shape a project, the city must analyze and mitigate the impact of project “as a whole” relative to a current-environmental-conditions baseline.²³⁰ Projects whose permitting is “not wholly ministerial and not entirely discretionary but a compound of both” have been treated as entirely discretionary for CEQA purposes.²³¹ In one case, an EIR was produced using a zoning-complaint-project baseline, similar to New York practice, and the California Court of Appeal rejected it out of hand.²³² The court faulted the EIR for not “present[ing] a clear or a complete description of the project's impacts compared with the effects of leaving the land in its existing state.”²³³

This line of cases is rooted in CEQA’s traditional premises: that new construction is bad for the environment,²³⁴ and that CEQA should be construed broadly to give “the fullest possible protection” to the environment.²³⁵ The working assumption is that requiring more environmental review and mitigation is the greener way. But as we’ve seen, the HAA inverts this premise when it comes to housing. The HAA declares new construction of zoning-compliant housing projects to be presumptively good for the environment,²³⁶ and it aims to “meaningfully and effectively curb[] the capability of local governments to deny, reduce the density for, or render infeasible housing development projects.”²³⁷ A reading of CEQA that leaves cities with open-ended discretion to require time-consuming studies and costly mitigation of so-called “impacts” that are not even proximately caused by the city’s exercise of discretion would do pointless violence to the policy of the HAA.

²²⁹ CAL. PUB. RES. CODE § 21080(a),

²³⁰ *People v. Dep’t of Hous. & Cmty. Dev.*, 45 Cal. App. 3d 185 (1975); *Friends of Westwood, Inc. v. City of Los Angeles*, 191 Cal. App. 3d 259 (1987); *Friends of Juana Briones House v. City of Palo Alto*, 190 Cal. App. 4th 286 (2010). See also *KOSTKA & ZISCHKE*, *supra* note 16, § 4.27. But see *McCorkle Eastside Neighborhood Group v. City of St. Helena*, 31 Cal. App. 5th 80 (2018) (holding that limited discretion conferred by city’s design review ordinance does not trigger CEQA review, because the type of aesthetic changes authorized by the code could not mitigate environmental impacts within the meaning of CEQA). Note also that the CEQA Guidelines define “effect” and “impact” (synonymously) to mean “effects which are caused by the project.” 14 CAL. CODE REGS § 15358. Future environmental conditions not caused by the discretionary project are not impacts within the meaning of CEQA. It follows that a CEQA analysis ought to reflect some choice of a reference alternative (as opposed to the “current environmental conditions” baseline), for, as we have seen, it is nonsensical to speak of the “effect” of a course of action without comparing outcomes under that scenario to outcomes under an alternative course of action.

²³¹ *People v. Dep’t of Hous. & Cmty. Dev.*, 45 Cal. App. 3d at 193.

²³² *Woodward Park Homeowners Assn., Inc. v. City of Fresno*, 150 Cal. App. 4th 683, 707-09 (2007) (rejecting EIR whose “bottom-line conclusions ... emphasized the marginally increased impacts of the proposed project over build-out under existing zoning”). See also *City of Carmel-by-the-Sea v. Board of Supervisors*, 183 Cal.App.3d 229, 246 (1986) (holding that county must consider impacts of rezoning on existing physical environment; comparison of project possible under old zoning with project possible under proposed new zoning “bears no relation to real conditions on the ground”).

²³³ *Woodward Park*, 150 Cal. App. 4th at 708. Left unaddressed was the question of whether the city had legal authority to choose a project alternative that would leave the land in that state.

²³⁴ See, e.g., *Friends of Westwood*, 191 Cal.App.3d at 266-67 (“As applied to private projects, the purpose of CEQA is to minimize the adverse effects of new construction on the environment. ... Thus the touchstone is whether the approval process involved allows the government to shape the project in any way which could respond to any of the concerns which might be identified in an environmental impact report.”) (emphasis added).

²³⁵ *Id.* at 267 (“doubt whether a project is ministerial or discretionary should be resolved in favor of the latter characterization”).

²³⁶ CAL. GOV’T CODE § 65589.5(a)(1)(C) & (a)(2)(A).

²³⁷ CAL. GOV’T CODE § 65589.5(a)(2)(K).

In the near term, however, any effort to use the HAA to put a limiting gloss on misbegotten CEQA-baseline precedents would be complicated by the fact that those precedents have been incorporated into the official CEQA Guidelines.²³⁸ The Guidelines stipulate that “the physical environmental conditions in the vicinity of the project, as they exist at the time the notice of preparation [of the EIR] is published . . . will normally constitute the baseline physical conditions by which a lead agency determines whether an impact is significant.”²³⁹ This “existing conditions baseline” “shall not include hypothetical conditions, such as those that might be allowed, but have never actually occurred, under existing permits or plans.”²⁴⁰

The only exception that the Guidelines presently recognize is that an agency may use a “projected future conditions . . . baseline . . . if it demonstrates . . . that use of existing conditions would be either misleading or without informative value to decision-makers and the public.”²⁴¹ This exception codifies a practice that developed around very long-term projects, such as railways.²⁴² Neither the Guidelines nor any published case approves the use of a “future-conditions baseline” where the future in question is a build-out of the project site under an alternative development scenario. Then again, neither the Guidelines nor any published case has considered the implications of the HAA for CEQA baselines or causation.

Though it wasn’t written for the HAA problem, the Guidelines’ narrow allowance for “future conditions” baselines at least recognizes that circumstances may arise where the conventional baseline is inappropriate. And the crux of our argument is that it is misleading and uninformative – and a colossal waste of resources, and a serious threat to the environmental and housing policies of the HAA – to require developers to engage in a multi-year analysis of putative environmental “effects” that are the byproduct of a nondiscretionary statutory mandate, not the discretionary choices of the local permitting authority itself.

We have found only one case in which a court considered the relationship between the HAA and CEQA. *Sequoyah Hills Homeowners Assn. v. City of Oakland*²⁴³ concerned a housing development on vacant land in the Oakland Hills. The zoning of the site allowed up to 88 single-family homes, but the developer “pre-mitigated” by proposing to build only 46 homes.²⁴⁴ The city ordered an EIR using a current-conditions baseline and evaluated several alternatives, including one with only 36 homes.²⁴⁵ Neighboring homeowners sued, arguing that the EIR was insufficient because it failed to analyze additional lower-density alternatives as a way of mitigating the visual impact of the project.²⁴⁶ The Court of Appeal held that the city did not abuse its discretion.²⁴⁷ CEQA only requires consideration of “feasible” alternatives,²⁴⁸ the court

²³⁸ 14 CAL. CODE REGS. § 15369 & 15125(a) (citing cases).

²³⁹ 14 CAL. CODE REGS. § 15125(a).

²⁴⁰ 14 CAL. CODE REGS. § 15125(a)(3).

²⁴¹ 14 CAL. CODE REGS. § 15125(a)(2).

²⁴² See, e.g., *Neighbors for Smart Rail v. Exposition Metro Line Construction Auth.* 57 Cal. 4th 439 (2013).

²⁴³ 23 Cal.App.4th 704 (1993).

²⁴⁴ *Id.* at 709.

²⁴⁵ *Id.* at 710.

²⁴⁶ *Id.* at 715.

²⁴⁷ *Id.* at 714-16.

²⁴⁸ *Id.* at 715-16.

emphasized, and the reduced-density alternatives urged by the neighbors were foreclosed by the HAA and therefore infeasible as a matter of law.²⁴⁹

What the court did not point out (perhaps because no one challenged the city's use of a current conditions baseline) is that an EIR focused on the visual impacts of the Sequoyah Hills project was a huge waste of time and money. No one disputed that the project "would stand out because of its relatively higher density and its location on a prominent hillside overlooking the existing residential development."²⁵⁰ But the city didn't have discretion to make the developer choose an alternative with fewer homes, so the impact of the project should not have been characterized as "significant" unless it was shown that a significantly less obtrusive project of the same density could have been built on the site.²⁵¹

Oakland's determination that the Sequoyah Hills project could have a significant visual impact, followed by an EIR analyzing that impact and justifying it with a finding of overriding considerations ("our hands are tied by the HAA"), was a convoluted resolution of a CEQA problem that should have been handled with a simple finding about causation in the Initial Study. Something like this:

The developer proposes to build 46 single-family homes on vacant land whose zoning allows 88 such homes. The project would not violate any health or safety standards, and the HAA therefore forecloses denial or reduction in density. Any other project with 46 homes on the same site would mar the now-undeveloped vista to a substantially similar extent. The visual impact of the project relative to current conditions results from the Legislature's creation of an entitlement to build zoning-compliant projects. It is not caused by the city's exercise of its residual discretion. Accordingly, the asserted aesthetic impacts of the project do not provide grounds for preparation of an EIR. Cf. *U.S. Dep't of Trans. v. Public Citizen*, 541 U.S. 752 (2004).

D. The Governor's Role

Courts are conservative creatures. It's rare that they upend long-established precedents. Although the newly-super HAA provides a very good rationale for courts to revisit—and limit—the dubious CEQA-baseline precedents, other actors also have important roles to play.

Courts don't implement CEQA by themselves. CEQA authorizes the Governor's Office of Planning and Research and the Natural Resources Agency to issue implementing guidelines.²⁵² At least once every two years, the Office of Planning and Research "shall recommend proposed changes or amendments" to the Guidelines, which the Natural Resources Agency then can certify

²⁴⁹ *Id.* at 715-16.

²⁵⁰ *Id.* at 711.

²⁵¹ And even that's a stretch, as nothing in the *Sequoyah Hills* opinion suggests that Oakland had open-space-visual-impact guidelines, from which a least-intrusive project design (i.e., the green-reference benchmark) might be adduced. Absent such guidelines, the CEQA review should have used a project-as-proposed benchmark.

²⁵² CAL. PUB. RES. CODE § 21083.

and adopt.²⁵³ ²⁵⁴ If environmental review is to be reshaped by an HAA-informed theory of causation, the Guidelines are an excellent tool with which to do it.

The Guidelines are a good tool for this purpose not only because making policy and changing direction is, by tradition, more squarely in the agency wheelhouse than the judicial wheelhouse, but also because of politics.²⁵⁵ Through his appointments and directives, the Governor can shape the Guidelines.²⁵⁶ And, presently, the Governor is better positioned than any other state-level actor to navigate the politically treacherous waters of CEQA reform.

Though it was a noble environmentalism that made CEQA super in the 1970s, the continued strength of CEQA today has much to do with the constellation of interest groups—first and foremost the building-trades unions—that have mastered the art of using CEQA to extract costly concessions from developers.²⁵⁷ In expensive housing markets, the threat of CEQA litigation and delay can be used to make developers sign project-labor and “community benefit” agreements with influential unions and nonprofits.²⁵⁸ The building trades wield a lot of power in Sacramento,

²⁵³ *Id.* § 21083(f).

²⁵⁴ *See* California Bldg. Indus. Assn. v. Bay Area Air Quality Mgmt. Dist., 62 Cal. 4th 369, 381, 362 P.3d 792, 797 (2015) (“Whether the Guidelines are binding or merely reflect the Resources Agency’s interpretation of the statute, we should afford great weight to the Guidelines when interpreting CEQA, unless a provision is clearly unauthorized or erroneous under the statute.”); *id.* at 389-90 (stating that the Guidelines are owed “weight” because of the Resource Agency’s “expertise and technical knowledge,” and because they are adopted “pursuant to the California Administrative Procedure Act (APA).”)

²⁵⁵ A further point: risk-averse developers will not push the CEQA envelope without a strong basis for thinking that the courts will accept their innovations. If the Governor doesn’t use the Guidelines to invite HAA-tailored CEQA analysis of housing projects, the courts may never have an occasion to consider whether this type of analysis is legally sufficient. By contrast, if the Governor does use the Guidelines as we suggest, the interest groups that benefit from the status quo are sure to sue right away, and the courts have held that facial challenges to a new CEQA Guideline may be brought as soon as the Guideline takes effect. *See* Communities for a Better Env’t v. Cal. Res. Agency, 103 Cal. App. 4th 98, 106, 126 Cal. Rptr. 2d 441, 446 (2002), as modified (Nov. 21, 2002) (“At issue in this case is whether the subject Guidelines, which public agencies must follow to implement CEQA, facially violate CEQA statutes and case law. As such, the matter presents a concrete legal dispute ripe for our consideration.”).

²⁵⁶ The Governor has the power to appoint the Director of Planning and Research. Cal. Gov’t Code § 65038; *see id.* § 65037 (stating that the Director “shall be responsible to the Governor”). The Secretary of the Natural Resources Agency is appointed by the Governor, subject to Senate confirmation, and “hold[s] office at the pleasure of[] the Governor.” Cal. Gov’t Code § 12801. *See also* Miriam Seifter, *Gubernatorial Administration*, 131 Harv. L. Rev. 483, 527 (2017) (noting the “substantial control governors possess over the majority of state agencies that have no constitutional status”).

²⁵⁷ The extent of what is sometimes called “CEQA greenmailing” is impossible to quantify because of nondisclosure agreements, but anecdotal evidence of the practice and, especially, the vehemence with which the building trades lobby against CEQA reform suggest that the problem is substantial. *See generally* Manuela Tobias, *What One Thing Do Republican Recall Candidates Blame for California’s Housing Crisis?*, CalMatters, Sept. 7, 2021 (canvassing the debate over CEQA); Christian Britschgi, *How California Environmental Law Makes It Easy For Labor Unions To Shake Down Developers*, Reason, Aug. 21, 2019, <https://reason.com/2019/08/21/how-california-environmental-law-makes-it-easy-for-labor-unions-to-shake-down-developers/> (discussing mechanisms and reviewing evidence of CEQA greenmailing); Matt Levin, *Commentary: Five Things I’ve Learned Covering California’s Housing Crisis that You Should Know*, CALMATTERS, Jan. 6, 2021 (stating, as “Lesson 4,” that “[t]he state construction workers’ union has way more influence than you think it does,” and detailing union’s central role in killing bills that would create CEQA exemptions for housing development); Manuela Tobias, *Is Union Labor Requirement in the Way of Easing California’s Affordable Housing Crisis?*, CALMATTERS, June 16, 2021 (reporting on unions’ success in blocking any housing bill that does not include a “skilled and trained” labor requirement).

²⁵⁸ Britschgi, *supra* note 257.

and in recent years they've derailed every legislative proposal for CEQA reform or streamlining unless it requires qualifying projects to use union labor.²⁵⁹ Not even a trivial bill that would let churches build affordable housing without CEQA review could escape Labor's grip.

But Governor Newsom is riding high. He was elected by a twenty-four point margin.²⁶⁰ He defeated a recall attempt by the same margin.²⁶¹ The California Republican Party is all but dead,²⁶² and the odds that the Governor will face a strong Democratic challenger when he's up for reelection in 2022 are remote.²⁶³ A tussle with the building trades wouldn't derail his career.

Of course, no Governor can single-handedly make the HAA "stick" in a manner that limits abusive use of CEQA. If there were a legislative consensus that project-labor agreements are more important than housing production, the Legislature could quickly abrogate any reformist CEQA Guidelines and then override a gubernatorial veto. But it's a fair hope that no such veto-proof consensus exists. The Republican minority is no fan of CEQA,²⁶⁴ and Democratic legislators are loathe to override their co-partisan Governor.²⁶⁵ Moreover, politically vulnerable legislators, who wouldn't dare cast a roll call vote against the trades, may acquiesce in the appointment of pro-housing committee chairs, who in turn could block any bill that would reverse the Governor's reform of the CEQA Guidelines. It's also possible that a transparent, public debate about CEQA abuse – a debate that would probably accompany any legislative effort to roll back the reformed Guidelines – might itself subtly alter the politics of CEQA reform, in a way that gives the HAA the upper hand.²⁶⁶

²⁵⁹ See Tobias, *supra* note 257, Levin, *supra* note 257; see generally Miriam Seifter, *Further from the People: The Puzzle of State Administration*, 93 N.Y.U. L. Rev. 107, 135-36 (2018) (noting a dramatic increase in state-level lobbying over the last 15 years).

²⁶⁰ https://ballotpedia.org/California_gubernatorial_election,_2018.

²⁶¹ [https://ballotpedia.org/Gavin_Newsom_recall,_Governor_of_California_\(2019-2021\)](https://ballotpedia.org/Gavin_Newsom_recall,_Governor_of_California_(2019-2021)).

²⁶² A.B. Block, *Battered, California GOP Struggles to Maintain Toehold*, CAPITOL WEEKLY, Jan. 5, 2021, <https://capitolweekly.net/battered-california-gop-struggles-to-maintain-toehold/>.

²⁶³ Tiffany Stecker, *Newsom's Easy Win in California Recall a Boost for 2022 Race*, BLOOMBERG NEWS, Sept. 15, 2021 (quoting a Democratic insider calling him "really sort of unbeatable").

²⁶⁴ Tobias, *supra* note 257.

²⁶⁵ Joe Garofoli, *Why Lawmakers Won't Override a Veto from Newsom, or Any Other Governor*, S.F. Chronicle, Oct. 15, 2021.

²⁶⁶ A side note: Given the constellation of interests with a stake in the CEQA-and-housing fight, one might worry that an unexpectedly broad reading of the HAA, or of CEQA, would undermine future legislative reform by making it harder for swing voters in the Legislature to have confidence in the compromises they might secure. Professors Rodriguez and Weingast have argued that "expansionist" judicial interpretation of progressive federal statutes passed in the 1960s and early 1970s had exactly this effect vis-a-vis later Congresses. Daniel B. Rodriguez & Barry R. Weingast, *The Paradox of Expansionist Statutory Interpretations*, 101 NW. U.L. REV. 1207 (2007). Their argument has a lot of force in cases where an expansionist reading of the statute would disrupt a discernable legislative bargain. But where the statute being read expansively features a codified Legislative instruction to read it expansively (like that in the HAA), and where the expansive reading concerns a question the Legislature did not even debate (baselines and causation for CEQA analysis of HAA protected projects), it can't be said that the judiciary or the executive branch is undermining legislative compromise by giving effect to the codified interpretive instruction. Indeed, it's possible that when the Legislature added the interpretive instruction to the HAA in 2017, it did so because lawmakers wanted judges to interpret the statute in ways that would achieve prohousing objectives while saving lawmakers from taking politically "tough" votes against the trades. We don't know whether this is the case, any more than we know whether the CEQA-savings clause was added to the HAA in 1990 to propitiate the trades. But in the absence of any information about this, it would be odd for courts to refrain from fitting CEQA and

Although super-statutes on Eskridge and Ferejohn's telling embody great normative principles,²⁶⁷ it appears that CEQA's continued potency owes much to a small number of rent-seeking interest groups that depend on it. The generational clash between the HAA and CEQA is about power as much as principle.

IV. Conclusion

Most legal scholarship on administrative law and statutory interpretation focuses on federal law and seeks to reach trans-substantive answers to the Big Questions. Questions like, "When is an agency decision final for purposes of judicial review?," "What does exhaustion of administrative remedies require?," "In what circumstances may a court look behind the stated reasons for agency action?," and "When should the policies of one statute inform the interpretation of another?" Yet trans-substantive answers are often disappointingly elusive.

In exploring this family of questions in the context of one state (California) and one area of law (land use), we hope to open some eyes to the world beyond the federal paradigm, a world in which the Big Questions take on different and sometimes surprising hues. For example, the "pretext" inquiry, which can seem intractable, pointless, or even illegitimate in the context of federal administrative law (where the Administrative Procedures Act offers no textual support for it, and where the agency head is usually the alter ego of the President),²⁶⁸ looks much more appropriate when the agency is an elected city council, the domain is land use, and the council is constrained by a state law whose central premise is that city councils are not to be trusted in development permitting.

We also hope this Essay serves as a useful reminder that super-statutes aren't "super" for all time. In 1970, in the wake of massive construction projects and rapid development across the state, it was reasonable to believe that slowing construction down would help the environment. The foundational CEQA cases were decided accordingly. But today, slow construction of housing in developed, high-demand places has made housing wildly unaffordable where people want to live. Worse, it has undermined today's environmental goals: the little housing that is built tends to be in inland areas with increased fire risk and that often requires residents to commute for hours to work in carbon-spewing cars.²⁶⁹ Of course, the recent amendments to HAA didn't exempt housing from CEQA. But they strongly suggest that, at least in the context of housing, the Legislature has rejected some of CEQA's normative and institutional suppositions.

the HAA together in a way that honors the policies of both statutes because of some remote possibility that doing so would unravel a secret legislative bargain.

²⁶⁷ Eskridge & Ferejohn, *supra* note 5, at 1216-17 (stating that super-statutes "occupy the legal terrain once called 'fundamental law,' foundational principles against which people presume their obligations and rights are set," and that such statutes "are both principled and deliberative and, for those reasons, have attracted special deference and respect").

²⁶⁸ See Gavoor & Platt, *supra* note 131; Nou, *supra* note 131.

²⁶⁹ Jones et al., *supra* note 27, at 35.

When an older super-statute has been undermined by more recent enactments that the Legislature declares to be super, it's incumbent on courts and other actors to reassess how the older law should be applied, rather than mindlessly following the protocols of the earlier era.

FOR THE EXCLUSIVE USE OF COURTNEY.TOIAIVAO@HKLAW.COM

From the San Francisco Business Times:

<https://www.bizjournals.com/sanfrancisco/news/2021/12/13/sf-supervisor-floats-group-housing-regulations.html>

Exclusive: New Peskin ordinance would clarify group housing definition

Dec 13, 2021, 6:49pm PST **Updated: Dec 13, 2021, 7:36pm PST**

Supervisor Aaron Peskin plans to introduce two ordinances Tuesday to limit and further regulate group housing amid a proliferation of development proposals for small units that opponents say threatens to shortchange San Francisco families who need housing.

One ordinance would modify planning code language on group housing — generally, smaller units that do not need to contain full kitchens

The other ordinance would create a special use district permanently prohibiting new group housing projects in parts of Chinatown, North Beach, Nob Hill and the Tenderloin. The areas impacted are bounded by Bush, Market, Stockton and Polk Streets, as well as Union, Montgomery, California and Powell streets and Grant Avenue.



TODD JOHNSON | SAN FRANCISCO
BUSINESS TIMES

San Francisco Supervisor Aaron
Peskin

The legislation is expected to be considered by the Planning Commission and then be referred to the Land Use Committee upon introduction. Current projects already proposed in the pipeline are not affected by this.

Peskin told me on Monday the city has seen a proliferation of group housing proposals that, while touted by their developers as a means to create more affordable housing in working class neighborhoods, are not always responsive to the needs of existing residents.

He said the legislation, written in collaboration with the city's Planning Department and neighborhood groups, provides a "long overdue tweak" that is important in the conversation around "permanent housing for people who need it."

At issue is a 2005 interpretation of group housing by the then-zoning administrator that made it more "difficult to distinguish between a residential dwelling unit and a group housing unit" by allowing limited in-unit cooking facilities, per the legislation. That allowed group housing, designed to be an affordable option for permanent residents, to be used as a kind of temporary housing, it says.

The first ordinance would define group housing as residential units with no individual cooking facilities or kitchens, meaning that a developer may not build small studios with limited cooking appliances and call it group housing. The legislation does not provide minimum or maximum square footages for group housing units. Group housing units must provide lease terms of 30 days or more, up from a week required currently.

It would also require that 0.25 square feet of common space be provided for every square foot of private space in a group housing development, with at least 50% of the common space devoted to communal kitchens. It would grant exceptions for student housing projects and 100% affordable group housing projects.

If the ordinance is approved, group housing projects would have to provide at least one kitchen for every 20 group housing units.

Developers have come under fire for proposing group housing projects with limited in-unit cooking facilities. Critics say

developers are using the unclear definition to build more, smaller units without having to provide group-style, co-living amenities that cost more. The planning code requires group housing to provide one-third the open space required for a traditional dwelling unit, another reason why developers may seek to build group housing.

The legislation says group housing units often become unregulated corporate rentals or second and third homes, preventing them from serving as affordable homes for San Francisco residents.

Group housing units come with smaller floor plates and scaled-back amenities, making it difficult to accommodate families.

While group housing projects have been proposed across the city, certain neighborhoods like the Tenderloin and Chinatown already have a disproportionate share of the city's dense living arrangements in the form of Single Room Occupancy hotel buildings, of which 100% of the rooms must not exceed 350 square feet.

Peskin's office said Monday that the legislation was created in collaboration with the city's planning department and community stakeholders, and came in response to community demands and recommendations made by the department.

The recent controversy around a 316-unit group housing project proposed at the site of a church at 450 O'Farrell St. in the Tenderloin exposed ambiguity in city policy governing group housing. The project was originally proposed and entitled for 176 traditional housing units, and when its developer pivoted to group housing units between 350 and 850 square feet earlier this year, community stakeholders objected.

"Residents in the community felt there was a need for a different type of housing. We were seeing issues of overcrowding, issues of affordability, and these small micro group housing units not being able to meet a need in the neighborhood, especially at the scale and size of 450 O'Farrell," said Gabriella Ruiz, a senior planner with the Chinatown Community Development Corporation.

Laura Waxmann
Staff Reporter





Walkscore.com – San Francisco

https://www.walkscore.com/CA/San_Francisco

Walk Score 87 San Francisco is Very Walkable

Most errands can be accomplished on foot.



San Francisco is the 2nd most walkable large city in the US with 805,238 residents.

San Francisco has excellent public transportation and is very bikeable.

Find apartments in San Francisco's most walkable neighborhoods: Chestnut, Jackson and Downtown Loop Square.

Orlando, Florida San Francisco

Nearby Cities

Dillard Apartments, Berkeley Apartments, Bernal Heights, Daly City Apartments, San Marin Apartments, San Leandro Apartments, Redwood City Apartments, Alameda Apartments, South San Francisco Apartments, San Rafael Apartments

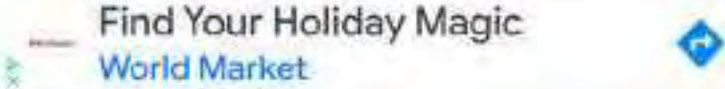

San Francisco Neighborhoods

Rank	Name	Walk Score	Transit Score	Bike Score	Population
1	Chinatown	100	100	74	6,646
2	Financial	100	100	91	21,848
3	Downtown Loop Square	99	100	74	2,112
4	North Beach	99	95	75	10,684
5	Potrero	99	95	78	5,096

See all San Francisco neighborhood scores [»](#) [View all San Francisco neighborhood scores](#)



SF Dept. of Homelessness & Supportive Housing @SF_HSH

Oct 19, 2021 · 1 tweets · [SF_HSH/status/1450576817245417474](#)

Exciting news - This acquisition just passed the Board of Supervisors! Looking forward to housing more folks exiting homelessness [https://www.sfchronicle.com/sf/article/For-years-the-Panoramic-housed-students-Now-S-F-16543850.php?utm_campaign=CMS%20Sharing%20Tools%20\(Premium\)&utm_source=t.co&utm_medium=referral](https://www.sfchronicle.com/sf/article/For-years-the-Panoramic-housed-students-Now-S-F-16543850.php?utm_campaign=CMS%20Sharing%20Tools%20(Premium)&utm_source=t.co&utm_medium=referral) via [@sfchronicle](#)

...

Most Popular

1. California to reimpose statewide indoor mask mandate as omicron

2. Breed tries to rein in S.F. school board with unprecedented charter...

3. Atmospheric river rolls into Bay Area. Here's when and where storms are...

4. Atm S.F. roac

-30%

Skip to main content

[Subscribe](#)

[Sign In](#)



SHOP NOW

SHOP NOW

SHOP NOW

BAY AREA // SAN FRANCISCO

For years the Panoramic housed students. Now S.F. wants to make it housing for homeless people



J.K. Dineen

Updated: Oct. 19, 2021 3:47 p.m.

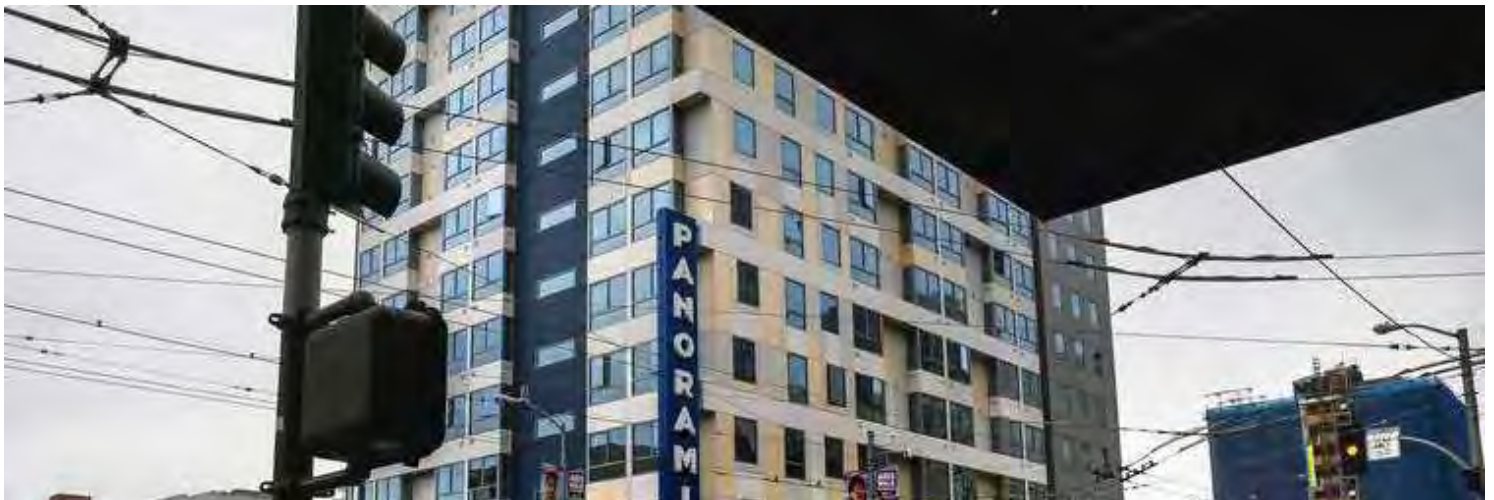
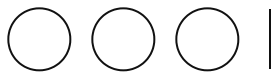



The Panoramic, on the corner of Mission and Ninth streets, has housed students. Now the city wants to buy the building and use it to provide homes for unhoused people.

Michael Macor/The Chronicle 2015

When developer Patrick Kennedy opened the Panoramic apartment complex at Mission and Ninth streets in 2015, the building was celebrated as a solution to San Francisco’s lack of student housing.

A handsome structure with a retro-looking blade sign, it was half pre-leased to the San Francisco Conservatory of Music and half to the California College of the Arts, both institutions that were struggling to find housing for their students amid a housing market with the nation’s fastest-rising rents.

ADVERTISEMENT

Article continues below this ad

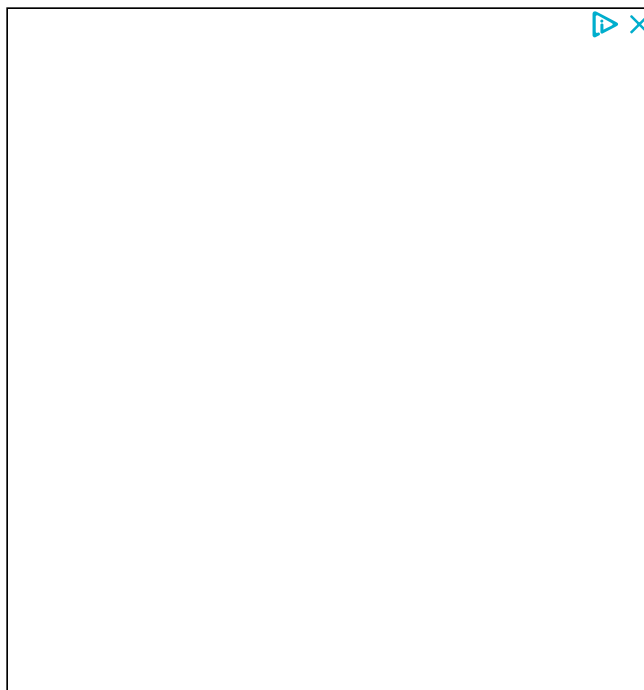

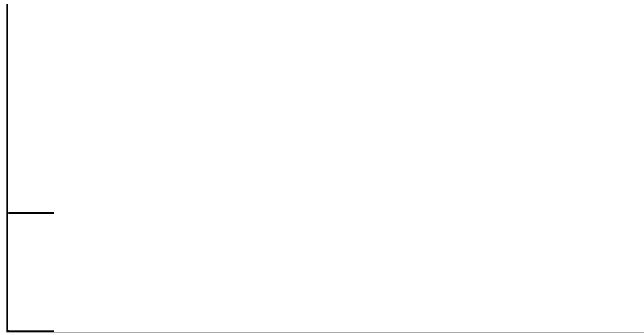

Now both those schools have built their own new student housing — the conservatory on Van Ness Avenue and College of the Arts near its Dogpatch campus — and Kennedy has its sights on a new use for the complex at 1321 Mission St.: apartments for formerly homeless people.

On Tuesday, the Board of Supervisors will vote on whether to spend \$86.6 million to acquire the property with state funds made available through Project Roomkey, an initiative launched in the early days of the pandemic to convert empty hotel rooms into housing for medically vulnerable homeless people. So far 10,952 rooms have been secured, including 2,059 in San Francisco.

Homelessness Crisis

This Silicon Valley county is trying to end a ‘hidden epidemic’ of homeless families. Will it work?

[Read Now](#)

S.F. advances homeless parking site in the Bayview despite protest

[Read Now](#)

While the 160-unit Panoramic is an atypical Roomkey candidate — because it was built as a dorm, not a hotel — it is especially useful because it includes 40 three-bedroom suites that can accommodate families with children, according to Mary

Kate Bacalao, director of external affairs and policy at Compass Family Services.

“It’s more than just a safe place to sleep for these families — many of whom are living in their cars right now,” she said.

The acquisition is facing resistance by some SoMa residents who feel that the stretch of Mission Street between Fifth Street and Van Ness, already heavy with social services and subsidized housing for the formerly unhoused, has deteriorated in recent years. While that part of Mission Street attracted new restaurants and businesses during the boom years of 2014 through 2018, those places have largely gone belly up.

ADVERTISEMENT

Article continues below this ad

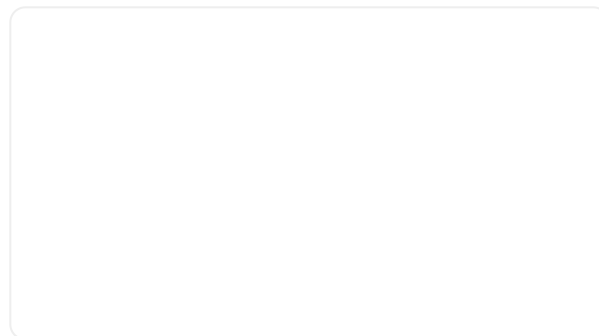

 POWERED BY CONCERT

There are more than a dozen vacant storefronts, and the lack of commerce and foot traffic has been a magnet to drug addicts and dealers, who frequently block the sidewalk and leave behind mounds of windblown trash, according to residents.

At a Board of Supervisors committee meeting, several west SoMa residents said the building is the wrong place to put formerly homeless people, some of whom have

struggled with drug addiction. It's hard to walk down the street without being offered narcotics, said one resident, adding that her family has had to grow used to "going to sleep with fentanyl wafting through our children's windows."

Supervisor Matt Haney responded that he empathizes with those concerns of residents who feel that the neighborhood has become a dumping ground for services that other neighborhoods wouldn't allow.

"SoMA and the Tenderloin take more than our fair share of the responsibility of housing people who are formerly homeless," he said. "To me, that does not mean that we stop doing what we need to do."

He said the city needs to create supportive housing as fast as possible, especially as some of the hotels that housed homeless people are repopulated with tourists and business travelers.

"The worst possible thing we could do is put these folks back on the street," he said. "We have to keep these people housed."

Drought Map

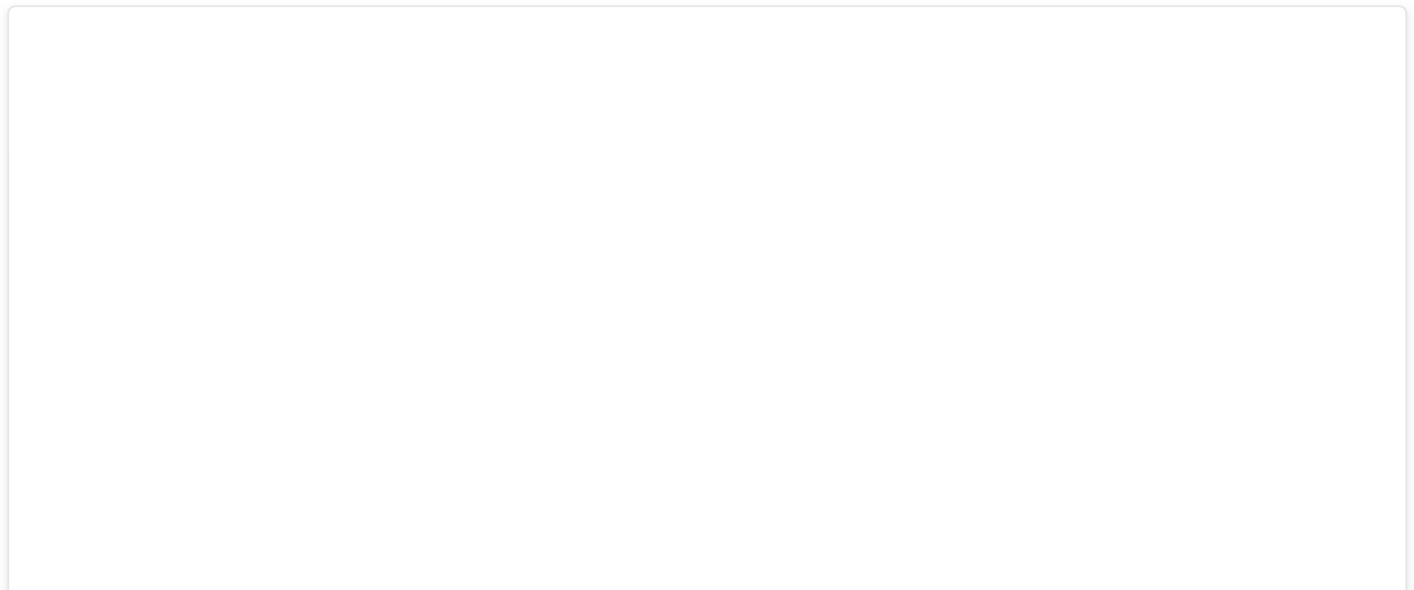

Track water shortages and restrictions across Bay Area

Check the water shortage status of your area, plus see reservoir levels and a list of restrictions for the Bay Area's largest water districts.

He said he took solace in the fact that the city is also approving Project Roomkey projects in the Sunset and Excelsior districts. The city is looking to acquire 1,500 units through Project Roomkey and received 85 proposals from hotels.

During the pandemic the Panoramic had already become home to about 50 tenants who are formerly homeless, several of whom spoke at last week's Board of Supervisors Land Use and Transportation Committee hearing.

One resident said that living there has "put a positive pressure toward normal thinking and behavior."

Another tenant, Jarvis Carpenter, said without the Panoramic he would likely still be on the streets.

"I have mental health issues and depression issues, and (living at the Panoramic has) done nothing but help me," he said.

State Sen. Scott Wiener, D-San Francisco, who wrote the legislation that provided incentives for developers of student housing, including the Panoramic, said he doesn't have a problem with the change.

"As long as it is being used to house someone who needs housing, that is a good

thing,” he said.

J.K. Dineen is a San Francisco Chronicle staff writer. Email: jdineen@sfchronicle.com Twitter: [@sfjkdineen](https://twitter.com/sfjkdineen)

Sign up for the Morning Fix newsletter

Top headlines from The Chronicle’s newsroom

Email

SIGN UP

By signing up, you agree to our [Terms of use](#) and acknowledge that your information will be used as described in our [Privacy Policy](#).



Written By
J.K. Dineen

Reach J.K. on

J.K. Dineen joined the San Francisco Chronicle in 2014, focusing on real estate development for the metro group, a beat that includes land use, housing, neighborhoods, the port, retail, and city parks. Prior to joining The Chronicle, he worked for the San Francisco Business Times, the San Francisco Examiner, the New York Daily News, and a bunch of newspapers in his native Massachusetts, including the Salem Evening News and the MetroWest Daily News.

He is the author of two books: *Here Tomorrow*, about historic preservation in California (Heyday, 2013); and the forthcoming *High Spirits* (Heyday 2015), a book of essays about legacy bars of San Francisco.

A graduate of Macalester College, Dineen was a member of Teach For America's inaugural class and taught sixth grade in Brooklyn, N.Y.

[VIEW COMMENTS](#)

Top of the News

Most Popular

1. California to reimpose statewide indoor mask mandate as omicron

2. Breed tries to rein in S.F. school board with unprecedented charter...

3. Atmospheric river rolls into Bay Area. Here's when and where storms are...

4. Atm S.F. roac

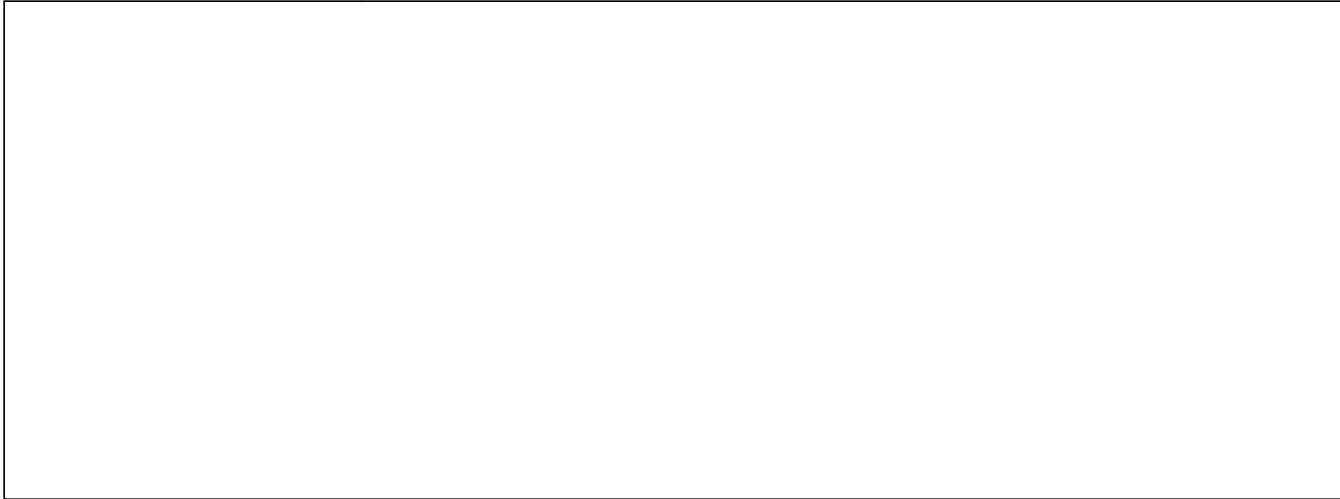

BAY AREA // SAN FRANCISCO

San Francisco plans to buy four properties to house homeless people across the city



Mallory Moench

Updated: Aug. 17, 2021 5:10 p.m.

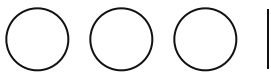



[Skip to main content](#)

[e-edition](#)



1 of 5

Owner Amit Motawala looks out over the Mission Inn. It's one of the locations San Francisco is looking into buying and turning into housing for homeless people.

Photos by Nina Riggio / The Chronicle

San Francisco is pursuing purchasing four properties, scattered across the city, by the end of the year to turn into housing with supportive services for homeless people.

The city reviewed dozens of potential sites and settled on a motel in the Outer Mission, an apartment building intended for student housing in SoMa, a single-room occupancy hotel in the Mission and a tourist hotel in Japantown. Nonprofits will run the sites and provide services such as a case manager to deal with tenant issues and connections to treatment for substance use or mental health.

The properties will add 368 housing units, part of a total goal of creating up to 1,000 units using \$400 million in local funding and a matching state grant that should become available in September. The exact amount from the state is not yet known. The purchases are part of the mayor's goal to buy or lease 1,500 units before the end of 2022.

ADVERTISEMENT

Article continues below this ad

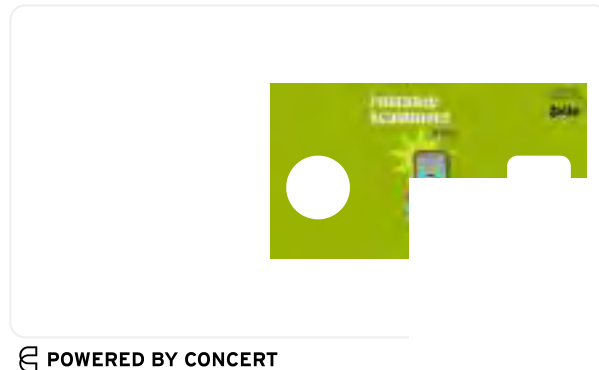

The need is dire: There were 8,000 homeless people in San Francisco at the last count in 2019, and advocates suspect the number rose during the pandemic. San Francisco has more than 10,000 people living in around 8,000 units of city-owned or leased permanent supportive housing.

Last year, the city moved thousands of people temporarily into hotels and bought two hotels with hundreds of units for new permanent housing for \$74 million, using a combination of local funding and money from state program Homekey. Gov. Gavin Newsom has pledged \$7 billion over two years for the program statewide.

Here are the four locations the city is considering buying:

Mission Inn: 5630 Mission St. in the Outer Mission, 52 units, all private baths, some in-unit

[SEE MORE](#)

Buying older buildings meant the city inherited problems — and [some existing discontented tenants](#) — but elected officials and advocates largely praised the purchases as a much faster and cheaper way to house homeless people than building new. Purchasing and rehabbing an existing property last year cost around \$323,000 per unit, compared to an estimated \$800,000 for a new unit of affordable housing.

Advocates have pushed the city to buy more using [an influx of money from the voter-approved business tax hike Proposition C](#).

The city is also [winding down its temporary hotel program and looking for permanent places for people](#), which the new purchases — one of which is already running as a temporary hotel — could help provide.

ADVERTISEMENT

Article continues below this ad

For the four sites under consideration, the city will conduct community outreach at the end of August. Officials will then ask the Board of Supervisors to approve the purchases and negotiate the final sale with owners, with the city mum on price until then.

The city hopes to scoop up 52 units at the Mission Inn motel on Mission Street south of Geneva Avenue and 25 units at the Eula Hotel, an SRO near 16th and Mission streets. The Panoramic, 160 units — a mix of studios and three bedrooms — in SoMa and the Kimpton Buchanan Hotel, 131 rooms in Japantown, are also in the mix.

Much of the city's permanent supportive housing is concentrated in the Tenderloin and SoMa, but two of the properties are in districts with little homeless housing: the Outer Mission and Japantown. Supervisor Ahsha Safaí, who represents the district where the Mission Inn is located, has supported buying more hotels and every neighborhood doing "its fair share" to house homeless people. Still, the plan could create controversy in a quieter residential community.

"These are once-in-a-lifetime opportunities," Safaí said. "For anyone who would be resistant to it, I would say you can't complain about people living on the streets and not do something about ensuring they have housing."

Some residents are already supportive. Steven Currier has lived in the Outer Mission for 28 years, currently seven blocks from the Mission Inn, and argued that people are "not only down and out in District 6 (where the Tenderloin is located)," but all over the city.

"Why not buy the hotel and transition these people who are homeless, which is a pandemic in itself to put them in permanent housing?" he said. "It's an honor for

... pandemic in itself, to put them in permanent housing," he said. "It's an honor for us to be able to help these people."

It's not the first time homeless programs have been set up in the district. Following complaints about trailers and vans parked on the streets, the city worked to open a space near Balboa Park where homeless individuals could live in their vehicles and receive services such as health care and connections to permanent housing.

Drought Map

Track water shortages and restrictions across Bay Area

Check the water shortage status of your area, plus see reservoir levels and a list of restrictions for the Bay Area's largest water districts.

Currier said the six-month community outreach process before the parking site opened was at times "very volatile, very vulgar." As co-chair of the safe parking program's community working group, he judged it a success, leading to help for those in need and fewer complaints about street conditions. The site closed so that

those in need and fewer complaints about street conditions. The site could be used for affordable housing could be developed on the property.

Currier said he hopes a motel converted into homeless housing would be better received.

For Mission Inn owner Amit Motawala, the opportunity to sell was appealing as the pandemic dragged on. The motel formerly served contractors who wanted to avoid a weeknight commute back to the Central Valley and international tourists who needed an affordable place to stay.

As occupancy dropped dramatically, Motawala found another way to fill rooms last year through local nonprofit Swords to Plowshares, which provided emergency housing to formerly homeless veterans before they settled into a permanent place. Around half the rooms are still available for veterans, he said.

Selling to fill the rooms with more people in need seemed a natural fit.

“We saw this opportunity and we think it is the right move,” Motawala said.

Mallory Moench is a San Francisco Chronicle staff writer. Email: mallory.moench@sfchronicle.com Twitter: [@mallorymoench](https://twitter.com/mallorymoench)

Sign up for the Morning Fix newsletter

Top headlines from The Chronicle’s newsroom

Email

SIGN UP

By signing up, you agree to our [Terms of use](#) and acknowledge that your information will be used as described in our [Privacy Policy](#).



Written By
Mallory Moench

Reach Mallory on

1
2
3
4
5
6
7
8
9
10
11
12
13
14
15
16
17
18
19
20
21
22
23
24
25
26
27
28

SUPERIOR COURT OF CALIFORNIA
COUNTY OF SANTA CLARA

40 MAIN STREET OFFICES, LLC,

Case No. 19CV349845 (Lead case,
consol. with Case No. 19CV350422)

Petitioner,

vs.

CITY OF LOS ALTOS, et al.,

ORDER GRANTING CONSOLIDATED
PETITIONS FOR WRIT OF MANDATE

Respondents.

CALIFORNIA RENTERS LEGAL
ADVOCACY & EDUCATION FUND, et al.,

Petitioners,

ORDER ON SUBMITTED MATTER

vs.

CITY OF LOS ALTOS, et al.,

Respondents.

These consolidated petitions for writ of mandate came on for hearing before the
Honorable Helen E. Williams on January 15, 2020, at 9:00 a.m. in Department 10 of the court.
Daniel R. Golub and Genna Yarkin of Holland & Knight appeared for petitioner 40 Main Street
Offices, LLC (Developer); Emily L. Brough of Zacks, Freedman & Patterson appeared for

1 petitioners California Renters Legal Advocacy & Education Fund, San Francisco Bay Area
2 Renters Federation, Victoria Fierco, and Sonja Trauss (collectively, Renters); Arthur J. Friedman,
3 of Sheppard Mullin Richter & Hampton LLP appeared for respondents the City of Los Altos, the
4 City of Los Altos City Council, and the City of Los Altos Community Development Department
5 (collectively, the City). The matter having been argued and submitted after the filing of post-
6 hearing supplemental briefing, no party having requested a statement of decision under Code of
7 Civil Procedure section 632 and rule 3.1590 of the California Rules of Court in this hearing
8 lasting less than eight hours, and the Court having carefully considered the pleadings, the papers
9 filed by the parties, the matters of which the Court takes judicial notice, the record received into
10 evidence, the arguments of counsel, and the applicable law, Court finds and orders as follows:

11 *1. Statement of the Case*

12 The lead case of these two consolidated actions is one for relief in mandate brought under
13 Code of Civil Procedure sections 1085 and 1094.5 (first three causes of action), as well as for
14 declaratory relief (fourth cause of action). It is brought by Developer against the City. Developer
15 has been trying to develop a mixed-use building in downtown Los Altos for many years, having
16 previously submitted multiple proposals all subject to discretionary review by the City.
17 Developer primarily alleges in its petition that the City unlawfully rejected its latest proposal
18 submitted under new, streamlined procedures established by Senate Bill 35 (Govt. Code,
19 § 65913.4, hereafter section 65913.4 or SB 35; further unspecified statutory references are to the
20 Govt. Code), remedial legislation enacted to promote the construction of housing within
21 California. Developer further alleges that in rejecting the proposal, the City also violated the state
22 Density Bonus Law (§ 65915) and the Housing Accountability Act (§ 65589.5), the provisions of
23 both of which may be invoked, as they were here, in a development application submitted under
24 SB 35.

25 Renters separately filed their petition challenging the City's course of conduct with
26 respect to Developers' proposed project (Case No. 19CV350422). They allege their own direct
27 and beneficial interests having been harmed in the City's denial of Developer's application for
28 streamlined approval. This separate action against the City, commenced one day before

1 Developer's action, has since been consolidated with Developer's action. Renters' petition in
2 mandate is also brought under Code of Civil Procedure sections 1085 and 1094.5, and seeks
3 relief in the first cause of action for the City's alleged violations of SB 35 and the Housing
4 Accountability Act. The second cause of action is for declaratory relief. Thus, Developer's and
5 Renters' claims for relief against the City essentially overlap.

6 *A. Summary of Administrative Record*

7 *1. Developer Applies for Streamlined Review*

8 On November 8, 2018, Developer applied for permission to construct a mixed-use
9 building with office space on the ground floor and residential units on the floors above at
10 40 Main Street in downtown Los Altos. (AR000001–AR000126 [application].) On the
11 application cover sheet—a City form entitled “City of Los Altos General Application”—
12 Developer checked boxes indicating that the “type of review requested” was
13 “Commercial/Multi-Family” and “Use Permit.” (AR000004.) The City had no other application
14 form cover sheet specific to a streamlined SB 35 application. In Developer's application, it stated
15 that it sought and qualified for streamlined review of its proposed development under SB 35.
16 (AR000006–AR000017.) Developer's application included a project summary, a discussion of
17 and chart detailing the proposed development's compliance with objective standards, renderings,
18 blueprints, proposed landscaping, a preliminary plan to manage construction, and a title report.
19 (AR000006–AR000126.)

20 *2. The City's Initial Response*

21 On December 7, 2018, the City—acting through Community Development Director Jise
22 Biggs—sent Developer correspondence in which it expressed its refusal to conduct either a
23 further streamlined or standard, discretionary review. (AR000127–AR000149.) The
24 correspondence reflects that the City appeared to treat Developer's single development
25 application as two distinct “applications submitted on November 8, 2018”—one for streamlined
26 review under SB 35 and one for standard, discretionary review—which perceived dual
27 applications purportedly could not be concurrently processed. (AR000129, AR000127.) In this
28

1 regard, the City said, “this application results in two applications that have been submitted for
2 this site. One or the other of the projects must be withdrawn.” (AR000127.)

3 As for the City’s direct response to the application for streamlined review—a letter that
4 contained within its subject line the reference “SB 35 Determination” and which letter
5 specifically referenced SB 35—the City stated that it had conducted a review, made a decision,
6 and determined that the proposed development did not qualify for streamlined review under
7 section 65913.4. The letter enumerated two reasons for the City’s denial decision. First, “the
8 project does not provide the percentage of affordable dwelling units required by the State
9 regulations.” (AR000127.) The City cited section 65913.4, subdivisions (a)(4)(A) and (B)(ii) and
10 a document prepared by California’s Department of Housing and Community Development
11 (HCD). (AR000127.) The HCD report lists Los Altos as a municipality in which streamlining
12 applications can be submitted for proposed developments with “> 50% affordability” due to the
13 failure to meet the [Regional Housing Needs Allocation or Assessment (RHNA), per § 65580 et
14 seq.] list low income households as compared to the “≥ 10% affordability” threshold for
15 streamlining applicable to municipalities that missed their targets for both low and moderate
16 income households. (AR000127, citing HCD Determination Summary (Jan. 31, 2018)
17 <[https://www.hcd.ca.gov/community-development/housing-
19 element/docs/SB35_StatewideDeterminationSummary01312018.pdf](https://www.hcd.ca.gov/community-development/housing-
18 element/docs/SB35_StatewideDeterminationSummary01312018.pdf)> [as of Mar. 2, 2020].)
20 Second, the City cited section 65913.4, subdivision (a)(5)—the provision of SB 35 requiring
21 consistency with objective zoning standards and objective design review standards¹—and stated
22 that the project lacked “the required number of off-street residential and visitor parking spaces”
23

24
25 ¹ Under section 65913.4, subdivision (a)(5): “ ‘objective zoning standards’ and ‘objective
26 design review standards’ mean standards that involve no personal or subjective judgment by a
27 public official and are uniformly verifiable by reference to an external and uniform benchmark or
28 criterion available and knowable by both the development applicant or proponent and the public
official before submittal. These standards may be embodied in alternative objective land use
specifications adopted by a city or county, and may include, but are not limited to, housing
overlay zones, specific plans, inclusionary zoning ordinances, and density bonus ordinances”

1 and “adequate access/egress to the proposed off-street parking.” (AR000127.) The City did not
2 identify what these parking standards were or where they could be located.

3 The letter concluded by saying, “If you elect to pursue *other* approval/permit avenues for
4 the project that is the subject of this notice, the applications, fees, deposits, studies, and
5 information contained in the attached Notice of Incomplete Application are required to continue
6 an evaluation of the project.” (AR000128, italics added.) The letter did not say that Developer’s
7 submitted SB 35 application was perceived to be incomplete, or suggest that the City’s further
8 review of Developer’s SB 35 application was conditioned on receipt of additional specified
9 materials or information. Rather, the letter denied that application for the reasons stated.

10 As for the purported discretionary application, the City declined to review it on the
11 asserted basis that it was “incomplete.” (AR000128.) The City’s letter, titled “Notice of
12 Incomplete Application” and which omitted SB 35 in the subject line, listed 24 items that
13 Developer needed to submit before the City would treat the application as complete and consider
14 it on its merits. (AR000129–AR000132.) For example, the City asserted that Developer had not
15 submitted complete documentation to substantiate its density-bonus request. (AR000148.) The
16 City indicated that the additional materials had to be provided within 180 days—by June 6,
17 2019—or the application would be deemed expired. (AR000129.)

18 3. *Developer Responds*

19 On January 10, 2019, Developer wrote to the City to point out perceived errors in the
20 City’s correspondence rejecting the application for streamlined review under SB 35.
21 (AR000150–AR000166.) Developer argued that the City’s stated reasons for its decision were
22 facially inadequate and substantively incorrect. (AR000151.) Developer stated that because the
23 City had not “validly” identified a conflict with applicable statutory objective standards and
24 could no longer do so within the statutory SB 35 statutory timeframe, the project was deemed to
25 comply and therefore qualified for streamlined review and permitting. (AR000151.)

26 In support, as for the City’s first stated basis for denial, Developer explained that the City
27 had improperly relied on an outdated HCD determination of the municipalities subject to
28 streamlining. (AR000151.) Developer pointed out that while the City had relied on a January

1 2018 determination, HCD had updated its determination in June 2018. (AR000151.) The June
2 2018 determination said that the City’s threshold for streamlining is the more inclusive, 10
3 percent threshold. (AR000151, AR000161.) On this basis, Developer asserted that the City had
4 erroneously determined that it was only subject to the streamlining process for projects with 50
5 percent as compared to 10 percent affordability. (AR000151–AR000152.)

6 Next, as for the City’s second stated reason for the denial—insufficient parking spaces
7 and “adequate access/egress to the proposed off-street parking”—Developer asserted that the
8 City had failed to identify the objective standards with which the project conflicted; relied in part
9 on a subjective, discretionary standard; and was otherwise incorrect. (AR000152–AR000154.)
10 Developer elaborated that no standard addressing ingress and egress from the parking area was
11 identified in the City’s decision and that the adequacy of ingress and egress was not an objective
12 standard that could be evaluated in the course of streamlined review. (AR000154.) Developer
13 also pointed out that section 65913.4, subdivision (d)(2) prohibited the City from requiring more
14 than one parking space per unit of housing. (AR000153.) According to Developer, it had
15 proposed more than adequate parking because it planned to develop 18 parking spaces for only
16 15 units of housing and was not required to develop additional parking for the offices due to the
17 City’s public parking district. (AR000153–AR000154; AR000166 [architect statement on
18 parking compliance, including ADA].)

19 Developer also asserted that the City had not made the requisite findings for having
20 rejected the project under section 65589.5, the Housing Accountability Act. (AR000155.) Then,
21 Developer remarked that, based on the City’s own representations in the incomplete notice, that
22 notice was immaterial to the application for streamlined review and the points it contained solely
23 concerned issues that might be addressed in a standard, discretionary review process.
24 (AR000156–AR000157.) Developer concluded by asserting its expectation that any streamlined
25 public oversight must be completed by February 6, 2019, in accordance with the section 65589.5
26 90-day deadline.

4 *The City Stands Its Ground*

1
2 On February 6, 2019, the City responded to Developer's letter. (AR000168-AR000172.)
3 The City asserted that it had correctly determined that the project was inconsistent with the
4 streamlining criteria while simultaneously asserting that the application for streamlined review
5 did not have sufficient information to allow the City to fully evaluate the criteria in section
6 65913.4. (AR000168.) The City then stated that it "*finds and determines that the Project is not*
7 *eligible for issuance of a streamlined ministerial permit.*" (AR000169.) The City agreed to
8 consider any request that would "*enable a determination of the Project's SB 35 eligibility or*
9 *otherwise process the Application if and when*" additional information was provided.
10 (AR000169.)

11 Next, the City responded to some of the specific points raised by Developer.
12 (AR000169.) The City conceded the error in its earlier, first-stated reason for having denied the
13 streamlining application; it acknowledged that under the correct and operative determination
14 from HCD, the affordability threshold for streamlining was 10 percent, not 50 percent.
15 (AR000169.) As for the City's earlier second-stated reason for having rejected the streamlining
16 application, the City turned to the notice of incomplete application instead of the denial letter.
17 (AR000169.) The City concluded that notes 18 and 19 in that notice of incomplete application
18 were sufficient to apprise Developer of the problem with its proposal and the inability of the City
19 to evaluate the proposed parking.² (AR000169-AR000170.)

20 Finally, the City said that because the streamlining application was incomplete, the City
21 was not required to comply with the Housing Accountability Act and also had properly rejected
22 the application based on its inability to evaluate the project's eligibility for a density bonus.
23 (AR000170.)

24
25
26 ² Notes 18 and 19 do not identify any objective standard or clear inconsistency with such
27 a standard in any event. (AR000131.) Note 18 states that two parking spaces will be affected by
28 the driveway. (AR000131.) Note 19 states that parking circulation is "inadequate" and questions
 where cars would wait to enter the underground parking garage. (AR000131.)

1 5. *Developer States Intent to Pursue Legal Action*

2 On February 19, 2019, Developer countered the City's response in a letter documenting
3 the problems with and inconsistencies between the City's initial action on December 7, 2018,
4 and how it had attempted to recharacterize that action in the February 6th letter. (AR000172–
5 AR000182.) Developer recounted the history of its attempts to develop the project through the
6 discretionary review process since 2013 and the purpose of section 65913.4, emphasizing the
7 ways in which the statute was designed to remedy precisely the type of agency conduct at issue
8 here. (AR000175–AR000176.) Developer also addressed the specific legal issues raised in the
9 parties' preceding correspondence. (AR000177–AR000181.)

10 In concluding, Developer observed that the City appeared to be unwilling to follow the
11 law or work with Developer on approving the SB 35 proposal, leaving it with no option other
12 than legal action. (AR000181.) Developer said that it did not appear there was any available
13 administrative remedy, such as an appeal, to be exhausted before commencing suit. (AR000181.)
14 Nevertheless, Developer indicated that it had submitted a claim³ to the City Clerk under the
15 Government Claims Act (§ 900 et seq.) out of an abundance of caution and invited the City to
16 advise if it concluded that some applicable administrative procedure, in fact, existed that
17 Developer should pursue before initiating legal action. (AR000181.) Developer offered that it
18 remained open to discussing alternatives to litigation but otherwise intended to file suit within 90
19 days of the City's February 6th letter. (AR000181.)

20 6. *Developer Administratively Appeals*

21 On February 21, 2019, the City informed Developer by email and through written
22 delivery of the same that its SB 35 denial was subject to an administrative appeal. (AR001203–
23 AR001206.) The City insisted an administrative appeal was required despite acknowledging that
24 Los Altos Municipal Code section 1.12.020, entitled "No appeal from ministerial acts," provides
25 that appeal procedures do not apply when an act or decision is ministerial. The City informed
26 Developer that if it wished to "challenge the City's decision on this matter, an appeal must be
27

28

³ Developer's claim appears in the record at AR001201–AR001202.

1 filed by no later than fifteen calendar (15) days from the date of the [February-6] letter, by the
2 close of business 4:30 pm on THURSDAY FEBRUARY 21, 2019." (AR001205.) The City
3 provided Developer with the mandatory application form for the appeal and stated that "[f]ailure
4 to timely appeal will preclude you, or any interested party, from challenging the City's decision
5 in court." (AR001205–AR001207.)

6 In other words, the City gave Developer less than eight hours' notice of its interpretation
7 of the Los Altos Municipal Code and position that an administrative appeal was required.

8 That same day, Developer submitted its appeal form along with a statement of the
9 grounds for its appeal and the record on which it was relying (including the correspondence
10 summarized above).⁴ (AR001208–AR001210.) In the weeks that followed, Developer frequently
11 corresponded with the City in an effort to ascertain what the process for the appeal would be and
12 when it would be heard. (AR001311–AR001328.)

13 On March 26, 2019, the City noticed the appeal for a public hearing before the City
14 Council to be held on April 9, 2019.⁵ (AR001216.) In correspondence from counsel for the City
15 to Developer the week before the hearing, it was asserted that the appeal was required because
16 the decision that the project was not eligible for streamlined review was not a ministerial act.
17 (AR001306.) Counsel went on to assert that April 9th was the earliest available time that the
18

19
20 ⁴ In Developer's cover letter for its appeal, it maintained that it did not believe there was
21 an avenue for appeal of a ministerial decision but was submitting the appeal to avoid any dispute.
(AR001210.)

22 ⁵ The City noticed this appeal for public hearing based on a staff report and
23 recommendation from counsel. (AR001238–AR001252 [staff report]; AR001253–AR001257
24 [presentation from Best Best & Krieger LLP].) The staff report delves into new substantive
25 issues on the SB 35 proposal, such as whether the project satisfies the two-thirds residential-use
26 requirement, that were not raised in the City's December 7, 2018 denial letter. (AR001242; see
27 also AR001260 [summarizing staff's reasons for denial that are purportedly the subject of the
28 appeal].) This seems to be because the City was advised that in determining the appeal, it would
conduct a de novo review of whether the project in fact complied with section 65913.4, instead
of ascertaining whether the initial denial had been insufficient or invalid such that the application
was deemed approved under SB 35. (AR001255.) Developer responded to these new points in
correspondence sent in connection with the appeal. (AR001284–AR001300.)

1 appeal could be heard based on the City Council's schedule and existing obligations.
2 (AR001308.) Counsel also maintained without explanation that the appeal was subject to a
3 public hearing, but that Developer would be allowed to present its case as well. (AR001309.)

4 On April 9th, Developer presented its appeal to the City Council, which also heard public
5 comment⁶ on the matter (including comments from Renters to the effect that the project was
6 deemed approved for streamlined permitting). (AR001231–AR001237; AR001928–AR002047
7 [hearing transcript].) On April 23, 2019, the City, acting through its City Council, denied the
8 appeal and did so by resolution. (AR002056–AR002078 [City Council minutes, report, and
9 resolution].)

10 *B. Summary of Allegations and Proceedings*

11 Renters and Developer (collectively, petitioners) commenced their respective actions on
12 June 12 and 13, 2019. Their hybrid petitions for writ of mandate and complaints for declaratory
13 relief essentially raise the same claims. They allege that in proceeding as described above in the
14 summary of the administrative record, the City unlawfully denied Developer's proposal in
15 violation of the streamlining statute (SB 35), the Housing Accountability Act (§ 65589.5), and
16 the Density Bonus Law (§ 6591.5). Based on these allegations, petitioners seek writs of mandate
17 under either Code of Civil Procedure section 1085 or section 1094.5, compelling the City to
18 approve Developer's streamlined application. They also seek a judicial declaration of their
19 entitlement to that approval under Code of Civil Procedure section 1060, along with injunctive
20 relief.⁷ The City separately answered both petitions.

21 On August 28, 2019, the Court consolidated the petitions for all purposes, and designated
22 Developer's action as the lead case. The City then lodged the administrative record with the
23 Court. And, on October 21, 2019, the City lodged a supplement. Petitioners filed a joint opening
24 brief, accompanied by a request for judicial notice, on November 1, 2019. The City opposed the
25

26 ⁶ Public comments can be located in the record along with other hearing materials.
(AR001333–AR001351, AR001907–AR001922, AR001924–AR001926.)

27 ⁷ Although Renters and Developer organized the causes of action in their petitions
28 differently, they seek the same types of relief on the same factual and legal bases.

1 petition on December 6, 2019, and presented the declaration of Jon Biggs, the City's Director of
2 Community Development. Petitioners then filed a joint reply and request for judicial notice
3 before the hearing scheduled for January 15, 2020. The hearing went forward as scheduled.
4 Upon receipt of post-hearing supplemental briefing ordered by the Court, the matter was
5 submitted.

6 *II. Petitioners' Requests for Judicial Notice*

7 Petitioners jointly request judicial notice of portions of the Los Altos Municipal Code
8 (RIN Ex. K) as well as legislative history materials, namely digests, reports, floor analyses, and
9 amendments to section 65913.4 (RIN Exs. A–J). With their reply, they seek judicial notice of
10 correspondence from ICD in response to their request for assistance. (See Golub Decl., Ex. 1.)
11 For the reasons that follow, petitioners' requests are granted.

12 A court may take judicial notice of municipal law. (Evid. Code, § 452, subd. (b); *The*
13 *Kennedy Con. v. City of Huntington Beach* (2017) 16 Cal.App.5th 841, 852 (*Kennedy*)). Thus,
14 the Court takes judicial notice of the Los Altos Municipal Code.

15 Next, a court may consider legislative history materials as an interpretative aid, but the
16 means of consideration and weight ascribed to these kinds of materials vary. (Cf. *People v. Cruz*
17 (1996) 13 Cal.4th 764, 773, fn. 5 (*Cruz*) with *Cummins, Inc. v. Super. Ct.* (2005) 36 Cal.4th 478,
18 492, fn. 11.) As for the text of enacted legislation (Assembly Bill 101 and Assembly Bill 1485),
19 including a redline version showing section 65913.4 as amended and in force today, (RIN
20 Exs. C, G–H), the Court takes judicial notice under Evidence Code section 452. While the
21 California Supreme Court has relied on precedent to take judicial notice of other legislative
22 history materials, such as committee reports and bill analyses, some dissenters have aptly
23 observed that such materials do not clearly fall within any enumerated category of Evidence
24 Code sections 451 and 452. (*Cruz, supra*, 13 Cal.4th at p. 794 (dis. opn. of Anderson, J.))
25 Accordingly, here, the legislative reports and analyses are not subject to judicial notice under the
26 Evidence Code. Nevertheless, precedent allows the Court to consider these reports and analyses
27 and to ascribe to them an appropriate weight in light of their authorship and function within the
28 legislative process.

From: [Board of Supervisors, \(BOS\)](#)
To: [BOS-Supervisors](#)
Cc: [BOS Legislation, \(BOS\)](#); [Calvillo, Angela \(BOS\)](#); [Mchugh, Eileen \(BOS\)](#); [Ng, Wilson \(BOS\)](#); [Somera, Alisa \(BOS\)](#); [Laxamana, Junko \(BOS\)](#)
Subject: FW: Correspondence 1 of 2 re 450-474 O'Farrell Street/532 Jones Street Project Application Case No. 2013.1535EIA-02 210861
Date: Tuesday, December 14, 2021 2:48:19 PM
Attachments: [2021-12-14 Letter re 450 \[2 of 2\].pdf](#)

From: Reena.Kaur@hklaw.com <Reena.Kaur@hklaw.com>
Sent: Tuesday, December 14, 2021 1:05 PM
To: Cityattorney <Cityattorney@sfcityatty.org>; Board of Supervisors, (BOS) <board.of.supervisors@sfgov.org>
Cc: Divya.Sen@hcd.ca.gov; housing@doj.ca.gov; senator.wiener@senate.ca.gov; david.murray08@gmail.com; ela@elastrong.com; davidc@dpclawoffices.com; pick@storzerlaw.com; storzer@storzerlaw.com; sonja@yimbylaw.org; Daniel.Golub@hklaw.com; Letitia.Moore@hklaw.com; Melanie.Chaewsky@hklaw.com
Subject: Correspondence 1 of 2 re 450-474 O'Farrell Street/532 Jones Street Project Application Case No. 2013.1535EIA-02

This message is from outside the City email system. Do not open links or attachments from untrusted sources.

Dear Counsel,

Please see the attached letter from Holland & Knight LLP regarding the 450-474 O'Farrell Street/532 Jones Street Project Application, Case No. 2013.1535EIA-02. Please ensure that this correspondence and its attachments are included in the record of proceedings for the above-captioned matter and are provided to the Board of Supervisors for the December 14 hearing on this matter. Due to the size of the letter, it has been split into two parts. Part 2 of 2 is attached here.

Thanks,

Reena Kaur | Holland & Knight

Practice Assistant

Holland & Knight LLP

50 California Street, Suite 2800 | San Francisco, California 94111

Phone 415.743.6916 | Fax 415.743.6910

reena.kaur@hklaw.com | www.hklaw.com

NOTE: This e-mail is from a law firm, Holland & Knight LLP ("H&K"), and is intended solely for the use of the individual(s) to whom it is addressed. If you believe you received this e-mail in error, please notify the sender immediately, delete the e-mail from your computer and do not copy or disclose it to anyone else. If you are not an existing client of H&K, do not construe anything in this e-mail to make you a client unless it contains a specific statement to that effect and do not disclose anything to H&K in reply that you expect it to hold in confidence. If you properly received this e-mail as a client, co-counsel or retained expert of H&K, you should maintain its contents in confidence in order to preserve the attorney-client or work product privilege that may be available to protect confidentiality.

1 Finally, “[w]here the meaning and legal effect of a statute is the issue, an agency’s
2 interpretation is one among several tools available to the court.” (*Yamaha Corp. of America v.*
3 *State Bd. of Equalization* (1998) 19 Cal.4th 1, 7 (*Yamaha*)). “An agency interpretation of the
4 meaning and legal effect of a statute is entitled to consideration and respect by the courts;
5 however, unlike quasi-legislative regulations adopted by an agency to which the Legislature has
6 confided the power to ‘make law,’ and which, if authorized by the enabling legislation, bind this
7 and other courts as firmly as statutes themselves, the binding power of an agency’s interpretation
8 of a statute or regulation is contextual: Its power to persuade is both circumstantial and
9 dependent on the presence or absence of factors that support the merit of the interpretation.”
10 (*Ibid.*) A formal opinion letter or informal correspondence expressing the position of the agency
11 may be presented to a court for consideration under *Yamaha* by way of a request for judicial
12 notice under Evidence Code section 452, subdivision (c). (See generally *Field v. Bowen* (2011)
13 199 Cal.App.4th 346, 370, fn. 5 [agency-prepared documents come within Evid. Code, 452,
14 subd. (c); see, e.g., *Linda Vista Village San Diego H.O.A., Inc. v. Tecolote Investors, LLC* (2015)
15 234 Cal.App.4th 166, 186.) Consequently, the Court takes judicial notice of HCD’s letter to
16 petitioners.

17 III. Discussion

18 The Court must answer two central questions to resolve the petitions. First, did
19 petitioners timely commence their respective actions? Second, do petitioners establish that they
20 are entitled to relief on the merits? The answer to both questions is yes.⁸

21
22 ⁸ As noted, both petitions are brought under Code of Civil Procedure sections 1085,
23 traditional mandate, and 1094.5, administrative mandate, without specification of which form of
24 mandate may apply to all or each of the discrete causes of action. Likewise, the City takes no
25 position on this question. Each of these statutes, by its terms and as discussed in case law,
26 typically applies in different, specified circumstances or settings. And each typically invokes
27 judicial review through its own nuanced lens or standard. As SB 35 involves an agency’s
28 ministerial duty to approve a qualifying development proposal and no administrative or public
hearing is contemplated, judicial review of an agency’s decision to reject a project for
streamlined review and permitting under SB 35 is more likely in traditional mandate under Code
of Civil Procedure section 1085. But here, the City insisted that an administrative appeal to the
City Council heard through the vehicle of a public hearing was required, which typically leads to
judicial review in administrative mandate under Code of Civil Procedure section 1094.5. And the

1 A. *The Action Is Not Time-Barred*

2 The City’s primary opposing argument is that petitioners failed to timely file and serve
3 their respective petitions within the 90-day limitations period set forth in section 65009. In
4 advancing this argument, the City asserts that it is not estopped from raising this defense based
5 on its insistence that Developer exhaust its administrative remedies by appealing to the City
6 Council (or, implicitly, that Renters so exhaust by their participation in this same administrative
7 process) before bringing this action. Petitioners argue both assertions are incorrect. And, in
8 supplemental briefing, petitioners contend and the City disputes whether the statute-of-
9 limitations defense is further overcome by the doctrine of equitable tolling. For the following
10 reasons, the Court rejects the City’s defense.

11 As a threshold matter, the City argues that the Court should assess the “gravamen” of the
12 claims and subject all of them to the 90-day limitations period in section 65009, subdivision
13 (c)(1)(E). Petitioners take issue with this approach. (RT at p. 25.) And the Court perceives the
14 City’s treatment of all the claims collectively based on their assessed “gravamen” to be imprecise
15 and problematic.

16 “[A] plaintiff is generally permitted to allege different causes of action—with different
17 statutes of limitations—upon the same underlying facts.” (*Thomson v. Canyon* (2011))

18
19
20 Housing Accountability Act, which a development proposal submitted under SB 35 may invoke,
21 specifically references judicial review in administrative mandate under Code of Civil Procedure
22 section 1094.5. (§ 65589.5, subd. (m).) Further, courts have reviewed a challenge to an agency’s
23 decision under the Density Bonus Law likewise through administrative mandate. (See, e.g.
24 § 65915, subd. (d)(3); *Friends of Lagoon Valley v. City of Vacaville* (2007) 154 Cal.App.4th 807,
25 812, 816–817 (*Lagoon Valley*)). The parties appear to proceed here on the assumption that
26 because the overarching relief in mandate sought by petitioners is deemed approval of the
27 development proposal under SB 35, relief under the Housing Accountability Act and the Density
28 Bonus Law is subsumed within that. In any event, both forms of mandate ultimately review for
and address an agency’s abuse of discretion, which would include a failure to perform a duty
compelled by law or a failure to proceed in a manner required by law—the fundamental essence
of all the claims here. Because of this, and because the particular form of mandate that is
applicable is not articulated or disputed by the parties, the Court proceeds to conduct its judicial
review and to adjudicate the action focused on abuse of discretion as so framed and without
specifically deciding whether the ultimate relief afforded comes through Code of Civil Procedure
section 1085 or section 1094.5.

1 198 Cal.App.4th 594, 605 (*Thomson*.) “A complaint may allege facts involving several distinct
2 types of harm governed by different statutory periods and, where it does so, one cause of action
3 may survive even if another cause of action with a shorter limitations period is barred.” (*Ibid.*)
4 But in doing so, “a plaintiff is not permitted to evade a statute of limitations by artful pleading
5 that labels a cause of action one thing while actually stating another.” (*Id.* at p. 606.) “California
6 courts therefore look to the gravamen of the cause of action.” (*Ibid.*) “[T]he nature of the right
7 sued upon and not the form of action nor the relief demanded determines the applicability of the
8 statute of limitations under our code.” [Citation.]” (*Hensler v. City of Glendale* (1994) 8 Cal.4th
9 1, 22–23.)

10 Here, as is permissible, petitioners allege that one set of facts gives rise to multiple claims
11 for relief based on different statutes. And, in pleading these distinct theories, petitioners do not
12 attempt to artfully mislabel their claims to evade the statute of limitations. They assert that they
13 are independently entitled to relief on all of the pleaded bases. Consequently, contrary to how the
14 City proceeds, this is not a scenario in which it is necessary to drill down to the gravamen of
15 each claim to uncover its true nature. And the City’s suggestion that the gravamen of each
16 independent claim is relief under section 65913.4 is not quite accurate. It follows that the City
17 errs in addressing all of the claims collectively as though they are necessarily subject to one
18 statute of limitations in lieu of establishing the limitations period applicable to each claim
19 pleaded.⁹

20 To illustrate, the Housing Accountability Act contains its own 90-day statute of
21 limitations. (§ 65889.5, subd. (m).) This limitations period runs “from the later of (1) the
22 effective date of a decision of the local agency imposing conditions on, disapproving, or any
23 other final action on a housing development project or (2) the expiration of the time periods
24
25

26 _____
27 ⁹ To be clear, the City does not argue that each distinct claim incidentally happens to be
28 subject to the same statute of limitations. Rather, the City asks the Court to treat the different
claims as identical and, on that basis, to apply one statute of limitations to all claims.

1 specified in subparagraph (B) of paragraph (5) of subdivision (h).”¹⁰ (§ 65589.5, subd. (m),
2 citing § 65950 [Permit Streamlining Act].) This particular statute of limitations applies to causes
3 of action based on the Housing Accountability Act.

4 Next, the Legislature enacted section 65009 because it found “there currently is a housing
5 crisis in California and it is essential to reduce delays and restraints upon expeditiously
6 completing housing projects.” (§ 65009, subd. (a)(1).) The statute “is intended ‘to provide
7 certainty for property owners and local governments regarding decisions made pursuant to this
8 division’ (§ 65009, subd. (a)(3)) and thus to alleviate the ‘chilling effect on the confidence with
9 which property owners and local governments can proceed with projects’ (*id.*, subd. (a)(2))
10 created by potential legal challenges to local planning and zoning decisions.” (*Travis v. County*
11 *of Santa Cruz* (2004) 33 Cal.4th 757, 765.) “To this end, section 65009 establishes a short statute
12 of limitations, 90 days, applicable to actions challenging several types of local planning and
13 zoning decisions” (*Ibid.*)

14 The City relies on the 90-day limitations period in section 65009 based on language in
15 subdivision (c)(1)(E), which provides that it applies when a petitioner seeks “[t]o attack, review,
16 set aside, void, or annul any decision on the matters listed in Sections 65901^[11] and 65903^[12], or
17 to determine the reasonableness, legality, or validity of any condition attached to a variance,
18 conditional use permit, or any other permit.” Based on the contents of sections 65901 and
19 65903—section 65009, subdivision (c)(1)(E) is best summarized as applying when a petitioner
20

21
22 ¹⁰ Section 65889.5, as effective January 1, 2020, contains an outdated reference to
23 subparagraph (B) of former paragraph (5) of subdivision (h) that cites to time standards in
24 section 65950 (the Permit Streamlining Act). Subparagraph (B) and the time standards therein
25 are now codified in paragraph (6) of subdivision (h), not paragraph (5), but the Legislature failed
26 to conform the reference in subdivision (m) upon making this amendment to subdivision (h),
27 which is clearly the result of oversight.

28 ¹¹ Section 65901 governs hearings on “conditional uses or other permits” as well as
zoning variances.

¹² Section 65903 governs appeals of a decision of the board of zoning adjustment or
zoning administrator.

1 challenges (1) the underlying decision of the board of zoning adjustment or zoning administrator
2 on a conditional use permit, other permit, or zoning variance; (2) the outcome of an appeal of
3 such a decision; or (3) the particular terms of a conditional use permit, other permit, or variance
4 (as compared to the ultimate decision to issue or refuse to issue the permit or variance). (See
5 generally *Save Lafayette Trees v. City of Lafayette* (2019) 32 Cal.App.5th 148, 155–159
6 [discussing scope and construction of section 65009].)

7 Petitioners argue that, if anything, the 180-day period in subdivision (d)(1) of
8 section 65009 applies because this action meets both of the criteria specified therein, namely:

9 “(A) It is brought in support of or to encourage or facilitate the
10 development of housing that would increase the community’s
11 supply of housing affordable to persons and families with low or
12 moderate incomes, as defined in Section 50079.5 of the Health and
13 Safety Code, or with very low incomes, as defined in Section
14 50105 of the Health and Safety Code, or middle-income
15 households, as defined in Section 65008 of this code. This
16 subdivision is not intended to require that the action or proceeding
17 be brought in support of or to encourage or facilitate a specific
18 housing development project.

19 “(B) It is brought with respect to the adoption or revision of a
20 housing element pursuant to Article 10.6 (commencing with
21 Section 65580) of Chapter 3, actions taken pursuant to Section
22 65863.6, or Chapter 4.2 (commencing with Section 65913), or to
23 challenge the adequacy of [a density bonus] ordinance adopted
24 pursuant to Section 65915.

25 Petitioners’ interpretation of section 65009, subdivision (d)(1) is not entirely persuasive.
26 While the project does seem to encourage housing development within the meaning of section
27 65009, subdivision (d)(1)(A), it is not especially clear that this proceeding is brought with
28 respect to “actions taken pursuant to Section 65863.6, or Chapter 4.2 (commencing with Section
65913)” within the meaning of section 65009, subdivision (d)(1)(B). This is because this latter
subdivision focuses on challenges to legislative actions as compared to ministerial or
adjudicatory permitting decisions. The legislative actions enumerated in section 65009,
subdivision (d)(1)(B) include the adoption or revision of a housing element, adoption of a zoning
ordinance, and the adoption of a density bonus ordinance. (See *Calvert v. County of Yuba* (2006)

1 145 Cal.App.4th 613, 623.) The only other action identified in that subdivision is an action taken
2 under Chapter 4.2 (commencing with section 65913). Petitioners assume that this reference
3 necessarily encompasses section 65913.4, SB 35, because it is part of Chapter 4.2. But this
4 interpretation does not necessarily appear to be correct under the principle of *noscitur a sociis*
5 that directs interpretation of a term in a list by reference to the other items in that list. (See *Kaatz*
6 *v. City of Seaside* (2006) 143 Cal.App.4th 13, 40.) Under that principle of interpretation, a court
7 interprets a term more narrowly if an expansive interpretation would make the term markedly
8 dissimilar from the other list items or make the other list items unnecessary or redundant. (*Ibid.*)

9 Here, interpreting “actions taken pursuant to ... Chapter 4.2 (commencing with Section
10 65913)” as encompassing the decision to ministerially approve a particular project under section
11 65913.4 would create a marked dissimilarity between that term and the other legislative actions
12 enumerated in section 65009, subdivision (d)(1)(B). Additionally, section 65913.4 is not the only
13 section within Chapter 4.2. Section 65913.1 requires that when zoning land or revising a housing
14 element a city designate sufficient land for residential use. And so, an action taken under section
15 65913.1 falls within Chapter 4.2 and constitutes a legislative action like the other actions
16 enumerated in section 65009, subdivision (d)(1)(B). Similarly, section 65913.2, also in Chapter
17 4.2, imposes limitations on the types of legislative actions a city may take when it comes to
18 regulating subdivisions. Thus, it seems the Legislature intended section 65009, subdivision
19 (d)(1)(B) to encompass legislative actions taken under Chapter 4.2, but not necessarily
20 ministerial or adjudicatory decisions. Consequently, petitioners’ interpretation of section 65009,
21 subdivision (d)(1)(B) as encompassing streamlined approvals or denials of projects under section
22 65913.4 is not convincing.

23 The City’s interpretation of section 65009, subdivision (c)(1)(E) is slightly more
24 appealing. While it is true that projects subject to streamlined review do not require conditional
25 use permits, section 65009, subdivision (c)(1)(E), including as incorporated in section 65009,
26 subdivision (c)(1)(F), encompasses a decision on “any other permit.” And so, arguably, even
27 when a project is subject to streamlined, nondiscretionary review, there is still a decision as to
28 whether to permit—meaning to allow—the development, which decision may be signified by the

1 issuance of a document or series of documents denominated as a "permit." And a decision made
2 under section 65913.4 might otherwise qualify within the meaning of section 65009, subdivision
3 (e)(1)(F) as a decision made before the issuance of any other permit.

4 Petitioners do not convince the Court that *Urban Habitat Program v. City of Pleasanton*
5 (2008) 164 Cal.App.4th 1561 (*Urban Habitat*) precludes the application of section 65009 here.
6 First, the facts of that case are distinct because the petitioners there claimed that the City of
7 Pleasanton had failed to update the housing element of its general plan and local development
8 law to meet its RHNA such that an impermissible inconsistency arose over time; in other words,
9 the city had failed to adapt to updated needs and requirements for adequate housing. (*Urban*
10 *Habitat*, at pp. 1566–1570, 1577.) The issue here is not whether the City failed to bring local law
11 and planning documents into compliance, but rather, whether it took an affirmative action on a
12 specific project that was unlawful. While petitioners characterize this as a failure to comply with
13 mandatory duties, this is not the same type of failure or omission that occurred in *Urban Habitat*.
14 Because that case is circumstantially distinguishable from the case now before this Court, and
15 given the broad interpretation afforded to section 65009 by other courts, petitioners' analogy is
16 not compelling.

17 Ultimately, even assuming all of petitioners' claims are subject to a 90-day statute of
18 limitations under either section 65009 or, as to the Housing Accountability Act claims,
19 section 65889.5, subdivision (m), they commenced their respective actions with 90 days of the
20 City's decision on the administrative appeal, which process the City insisted, full stop, was
21 required for exhaustion purposes. The City, through its City Council, made that "final" decision
22 on April 23, 2019. (AR002313.) Petitioners filed their petitions in June and served them by July
23 10th, within 90 days of the April 23rd adopted resolution. Accordingly, each petition in this
24 consolidated action is timely.

25 The Court accordingly rejects the City's contention that its initial rejection of the
26 streamlining application on December 7, 2018, necessarily accrued a cause of action under SB
27 35 or triggered the running of the statute of limitations as to any or all claims asserted. Contrary
28

1 to what it anticipatorily argues in its opposition, the Court finds that the facts here warrant
2 estoppel of this defense. Equitable tolling applies as well.

3 Equitable tolling and equitable estoppel are two distinct doctrines. (*Ashou v. Liberty*
4 *Mutual Fire Ins. Co.* (2006) 138 Cal.App.4th 748, 757–758.)

5 “Generally speaking, four elements must be present in order to apply the doctrine of
6 equitable estoppel: (1) the party to be estopped must be apprised of the facts; (2) he must intend
7 that his conduct shall be [*sic*] acted upon, or must so act that the party asserting the estoppel had
8 a right to believe it was so intended; (3) the other party must be ignorant of the true state of facts;
9 and (4) he must rely upon the conduct to his injury.” [Citations.]” (*Feduniak v. California*
10 *Coastal Com.* (2007) 148 Cal.App.4th 1346, 1359, quoting *Driscoll v. City of Los Angeles*
11 (1967) 67 Cal.2d 297, 305.) And “ [t]he government may be bound by an equitable estoppel in
12 the same manner as a private party when the elements requisite to such an estoppel against a
13 private party are present *and*, in the considered view of a court of equity, the injustice [that]
14 would result from a failure to uphold an estoppel is of sufficient dimension to justify any effect
15 upon public interest or policy [that] would result from the raising of an estoppel.” [Citation.]”
16 (*Feduniak, supra*, 148 Cal.App.4th at pp. 1359–1360.) “[C]ourts will not hesitate to estop the
17 government from asserting a procedural barrier, such as the statute of limitations or a failure to
18 exhaust remedies, as a defense to claims against it, where the government’s affirmative conduct
19 caused the claimant’s failure to comply with the procedural requirement.” (*Id.* at p. 1372.)

20 While estoppel typically arises from misrepresentations of fact, it may also apply when a
21 municipality or agency does not accurately advise a potential plaintiff about the existence or
22 availability of an administrative remedy, which advice may depend in part on mixed questions of
23 fact and law. (See, e.g., *Shuer v. County of San Diego* (2004) 117 Cal.App.4th 476, 487 (*Shuer*).)
24 For example, when the availability of an administrative remedy is unclear and the administrative
25 regulations are susceptible to different interpretations, a public entity may be estopped from
26 raising the failure to exhaust administrative remedies as a defense. (*Ibid.*)

27 “The equitable tolling of statutes of limitations is a judicially created, nonstatutory
28 doctrine. [Citations.]” (*McDonald v. Antelope Valley Community College Dist.* (2008) 45 Cal 4th

1 88, 99 (*McDonold*.) “It is ‘designed to prevent unjust and technical forfeitures of the right to a
2 trial on the merits when the purpose of the statute of limitations—timely notice to the defendant
3 of the plaintiff’s claims—has been satisfied.’ [Citation.]” (*Ibid.*, quoting *Appalachian Ins. Co. v.*
4 *McDonnell Douglas Corp.* (1989) 214 Cal.App.3d 1, 38.)

5 “Where exhaustion of an administrative remedy is mandatory prior to filing suit,
6 equitable tolling is automatic: ‘It has long been settled in this and other jurisdictions that
7 whenever the exhaustion of administrative remedies is a prerequisite to the initiation of a civil
8 action, the running of the limitations period is tolled during the time consumed by the
9 administrative proceeding.’ [Citations.]” (*McDonold, supra*, 45 Cal.4th at p. 101, quoting *Elkins*
10 *v. Derby* (1974) 12 Cal.3d 410, 414.) “This rule prevents administrative exhaustion requirements
11 from rendering illusory nonadministrative remedies contingent on exhaustion.” (*McDonold,*
12 *supra*, 45 Cal.4th at p. 101.) In other words, the doctrine of equitable tolling preserves a party’s
13 right to judicial review that would otherwise be rendered infeasible due to the consumption of
14 the limitations period by the administrative review process.

15 The facts here support the application of both equitable tolling and equitable estoppel.

16 The City mandated an administrative proceeding that consumed the limitations period
17 that it now contends was triggered by the initial denial letter on the streamlined application on
18 December 7, 2018. (AR001205.) But the City emphatically said to Developer that “an appeal
19 must be filed” and that “[f]ailure to timely appeal will preclude you, or any interested party, from
20 challenging the City’s decision in court.” (AR001205.) The City then insisted on scheduling a
21 public hearing on the administrative appeal before the City Council and delayed in doing so.
22 (AR001318–AR001324.) For mandamus claims brought under Code of Civil Procedure section
23 1094.5—and for any other claims in light of the emphatic language of the letter—the
24 administrative proceeding was mandatory. This is because a “writ is not available ... to
25 intermeddle in the preliminary stages of an administrative planning process” (*California*
26 *High-Speed Rail Authority v. Super. Ct.* (2014) 228 Cal.App.4th 676, 707; see also *California*
27 *Water Impact Network v. Newhall County Water District* (2008) 161 Cal.App.4th 1464, 1482–
28 1483 [only final decisions subject to review].) And, as petitioners point out, even if they contend

1 that the City's December 7, 2018 correspondence resulted in their SB 35 application being
2 deemed approved under streamlined review, with the City then insisting instead on an
3 administrative appeal, petitioners could pursue that appeal with the goal that the City Council
4 would not proceed to decide de novo whether the SB 35 application in fact qualified for
5 streamlined review but, rather, to recognize and decide that "deemed" approval of the SB 35
6 application under section 65913.4, subdivision (b)(2) for objective planning standards had
7 already occurred as a matter of law obviating the need for litigation.

8 And even treating the administrative proceeding as voluntary, tolling still applies.
9 (*McDonald, supra*, 45 Cal.4th at p. 105.) The Court rejects the City's rather incredible and
10 unsubstantiated claim that Developer's acquiescence under protest means that it did not
11 voluntarily pursue the administrative proceeding. The City fails to justify (through reasoned
12 analysis or authority) the insertion of a scienter requirement into the definition of voluntary in
13 this particular legal and procedural context. Accordingly, whether viewed as mandatory or
14 voluntary in character, the administrative proceeding that occurred here is the type of intervening
15 activity that tolls the limitations period.

16 Also, petitioners provided sufficient notice of their claims thereby fulfilling the purpose
17 of the statute of limitations before and during the administrative proceeding. The City asserts
18 without authority that Renters' submission of public comments was insufficient to put it on
19 notice of their claims. (See AR001334–AR001338; AR002344–AR002345.) Given the
20 specificity and content of Renters' communications with the City, the Court is not convinced by
21 the City's conclusory and unsubstantiated assertion. And, as a practical matter, it is unclear how
22 Renters could have proceeded without waiting for the disposition of Developer's administrative
23 appeal. Especially given the City's insistence on that appeal, it would result in an unjust and
24 technical forfeiture to allow the City to now disclaim the necessity of this administrative
25 proceeding. Because of the brevity of the 90-day limitations period, the absence of tolling during
26 the administrative proceeding would render judicial review illusory. Equitable tolling is just and
27 warranted under the facts and circumstances presented here. The City's supplemental brief does
28 not persuade the Court to reach a contrary conclusion.

1 Next, the City anticipatorily argues in opposition to the petitions that it is not equitably
2 estopped from raising the statute of limitations as a defense because estoppel applies when a
3 party misrepresents or conceals facts and not matters of law. (Opp. at p. 19:6–17, citing *Jordan*
4 *v. City of Sacramento* (2007) 148 Cal.App.4th 1487 (*Jordan*)). While the City’s statement of law
5 is not inaccurate on its face, it is incomplete and misleading. And the City’s analysis is
6 underdeveloped. Moreover, the City relies exclusively on *Jordan*, which is not analogous.

7 Here, the City vehemently asserted by letter that an administrative appeal was mandatory
8 and that it would raise the defense of exhaustion of administrative remedies to preclude
9 Developer from seeking judicial review of the City’s conduct absent an appeal. The City’s
10 representation as to the position it was taking, and would take in any litigation, is a
11 representation of fact. And, although Developer stated its opinion or belief that the City’s legal
12 analysis was incorrect, Developer was at the mercy of the City’s interpretation of its own
13 municipal code. In other words, the parties differed in their understanding of the law and in their
14 authority to interpret and enforce that law. As in *Shuer*, this type of informational and
15 interpretive asymmetry is sufficient to justify estoppel.

16 As for the second and fourth elements of estoppel—that the party to be estopped intended
17 that his conduct be acted upon, or that this party so acted such that the other party had a right to
18 believe the conduct was so intended, and that the other party relied on the conduct to his injury—
19 the City’s letter informing Developer of the requirement of an administrative appeal contained
20 such emphatic and mandatory language that it is reasonable to conclude the City intended to
21 induce Developer’s reliance thereon. And Developer acquiesced to the City’s representation to
22 its detriment, pursuing an administrative appeal albeit under protest. When faced with the
23 untenable choice of either suing immediately and facing dismissal for failure to exhaust, or
24 exhausting administrative remedies to preserve its claim of unlawful conduct, it was reasonable
25 for Developer to rely on the City’s interpretation of its own code and representation of the
26 exhaustion defense it intended to raise, particularly given the unequivocal and emphatic language
27 the City used to express this position. Further, under these circumstances, before having to
28 initiate litigation, Developer could reasonably so acquiesce to the City’s demand in an effort to

1 get the City Council to recognize the mandatory timelines and requirements of SB 35 and the
2 consequences of its having earlier failed to meet those provisions, and to correct its prior
3 erroneous approach.

4 Finally, the Court concludes that the injustice that would result in the absence of estoppel
5 is enough to justify application of the doctrine here.

6 For all of these reasons, the Court rejects the City's statute-of-limitations defense and
7 reaches the merits of petitioners' claims.

8 *B Petitioners Are Entitled to Relief on the Merits*

9 Petitioners allege that the City's conduct violated three different housing statutes:
10 (1) the streamlining statute (§ 65913.4, SB 35); (2) the Density Bonus Law (§ 65915); and
11 (3) the Housing Accountability Act (§ 65589.5).

12 *1. The City Failed to Comply with Section 65913.4*

13 *a. Statutory Background*

14 In 2017, the Legislature passed SB 35 to reform land-use and housing law, including by
15 creating "a streamlined, ministerial approval process for infill developments in localities that
16 have failed to meet their regional housing needs assessment [] numbers."¹³ (Sen. Rules Com.,
17 Rep. on Sen. Bill No. 35 (2017–2018 Reg. Sess.) May 27, 2017.)

18 Section 65913.4, subdivision (a) states in relevant part: "A development proponent may
19 submit an application for a development that is subject to the streamlined, ministerial approval
20 process provided by subdivision (b) and not subject to a conditional use permit if the
21 development satisfies all of the [] objective planning standards" set forth further in subdivision
22 (a).

23 _____
24 ¹³ As part of the housing element of a municipality's general plan, it must calculate its
25 Regional Housing Needs Allocation or Assessment (RHNA), which is the "existing and
26 projected need for housing" in the area for individuals and households of all income levels.
27 (*Fonseca v. City of Gilroy* (2007) 148 Cal.App.4th 1174, 1186, fn. 8, quoting Gov. Code,
28 § 65583.) If a municipality's present and projected housing needs exceed its housing stock and
land available for development, it must work to satisfy its RHNA by increasing the availability
of land for housing development by, for example, changing zoning and development restrictions.
(Gov. Code, § 65583, subd. (c)(1)(A).)

1 The objective planning standards that operate as eligibility criteria for streamlined,
2 ministerial review consist of inclusionary and exclusionary criteria. In the abstract, the
3 inclusionary and exclusionary criteria balance the primary policy of expediting housing
4 construction with the competing policy of safe, well-designed construction as embodied in
5 existing law. To illustrate, a proposed development must be “a multifamily housing development
6 that contains two or more residential units” in an urban area that will not displace existing rent-
7 controlled and income-restricted housing. (§ 65913.4, subs. (a)(1)–(2), (a)(7).) A mixed-use
8 development still qualifies if “at least two-thirds of the square footage of the development [are]
9 designated for residential use.” (§ 65913.4, subd. (a)(2)(C).) Exclusionary criteria disqualify a
10 development proposed for construction in or on a coastal zone, fire zone, flood plain, earthquake
11 fault zone, hazardous-waste site, wetland, or prime farmland. (§ 65913.4, subd. (a)(6).)

12 Currently, the statute specifies that when evaluating consistency with the standards
13 above, a development is consistent “if there is substantial evidence that would allow a reasonable
14 person to conclude that the development is consistent with the objective planning standards.”¹⁴
15 (§ 65913.4, subd. (b)(3).) Unless an agency timely explains to a developer in writing the reasons
16 why the proposed development is not consistent with the eligibility criteria, “the development
17 shall be deemed to satisfy the objective planning standards in subdivision (a).” (§ 65913.4,
18 subs. (b)(1)–(2).) An agency’s deadline for notifying a project proponent of ineligibility for
19 streamlined, ministerial review is either 60 or 90 days depending on the size of the proposed
20 development. (§ 65913.4, subs. (b)(1)(A)–(B).)

21 Proposed developments that qualify for streamlined, ministerial review may still be
22 subject to design review or public oversight with the limitation that this oversight “shall be
23 objective and be strictly focused on assessing compliance with criteria required for streamlined
24 projects, as well as any reasonable objective design standards published and adopted by
25 ordinance or resolution by a local jurisdiction before submission of a development application,
26

27 ¹⁴ Section 65913.4, subdivision (b)(3) became effective January 1, 2020. (Sen. Bill
28 No. 235 (2019–2020 Reg. Sess.) § 5.3; Assem. Bill No. 1485 (2019–2020 Reg. Sess.) § 1.)

1 and shall be broadly applicable to development within the jurisdiction.” (§ 65913.4, subd. (c)(1).)
2 The design review must be completed, if at all, within 90 or 180 days¹⁵ depending on the size of
3 the development and “shall not in any way inhibit, chill, or preclude the ministerial approval
4 provided by this section or its effect”¹⁶ (§ 65913.4, subd. (c)(1).)

5 *ii. Application*

6 The City’s notice of inconsistency here, its SB 35 denial letter of December 7, 2018, was
7 neither code-compliant nor supported by substantial evidence.

8 Section 65913.4 subdivision (b)(1) provides: “If a local government determines that a
9 development submitted pursuant to this section is in conflict with any of the objective planning
10 standards specified in subdivision (a), it shall provide the development proponent written
11 documentation of which standard or standards the development conflicts with, and an
12 explanation for the reason or reasons the development conflicts with that standard or standards
13” The Court concludes here that the City failed to comply with this notice requirement
14

15
16 ¹⁵ This means that for a smaller development, the deadline for notice of ineligibility is
17 60 days (§ 65913.4, subd. (b)(1)(A)) and an agency may take an additional 30 days to complete
18 design review or public oversight for a total of 90 days (§ 65913.4, subd. (c)(1)). For a larger
19 development, the deadline for notice of ineligibility is 90 days (§ 65913.4, subd. (b)(1)(B)) and
20 an agency may take an additional 90 days to complete design review or public oversight for a
21 total of 180 days (§ 65913.4, subd. (c)(2)).

22 ¹⁶ Notably, while section 65913.4, subdivision (c) gives localities additional time to
23 review objective design standards, the Legislature also enumerates compliance with “objective
24 design review standards” as an objective planning standard—an eligibility criterion—in
25 subdivision (a)(5). There does not appear to be a substantive distinction between these two terms.
26 The descriptions in subdivisions (a)(5) and (c) of what design standards may be applied are so
27 similar that they suggest the terms are equivalent. The statutory framing of design standards as
28 both eligibility criteria and criteria capable of review during the extended timeframe for public
oversight is problematic because of the distinct deadlines for making those distinct
determinations. Treating compliance with objective design standards as an objective planning
standard under subdivision (a) arguably renders as surplusage the later deadline for design
review in subdivision (c)(1). Courts typically avoid interpreting statutes in such a manner.
(*Arnett v. Dal Cielo* (1996) 14 Cal.4th 4, 22.) Ultimately, the Court need not resolve this
ambiguity based on the particular record and arguments advanced here. The City did not comply
by either deadline and does not ask for additional time to conduct public oversight in its
supplemental brief on the scope of relief that is warranted.

1 because the City did not adequately identify objective standards and provide an explanation of
2 inconsistencies supported by substantial evidence in its SB 35 denial letter.

3 First, the City did not adequately identify applicable objective standards with which the
4 project did not comply. The City conceded its initial error in asserting that a higher percentage of
5 affordable units was required; it had relied on an outdated and incorrect HCD determination.
6 (AR000169.) Thus, it is undisputed that the first bullet point in the City's denial letter was based
7 on an incorrect and inapplicable standard.

8 As for the other two bullet points, the City did not adequately identify the standards or
9 code provisions it was referring to or relying on. It concluded the project lacked "the required
10 number of off-street residential and visitor parking spaces" and "adequate access/egress to the
11 proposed off-street parking." (AR000127.) But it is not apparent from this vague statement just
12 what those purported standards are or where they can be located. Thus, the City did not
13 adequately identify the parking standards it was relying on. And notwithstanding the opacity and
14 ambiguity of the City's statement, it is apparent that it was not relying on permissible, objective
15 standards for parking. First, section 65913.4, subdivision (d)(2) states that "the local government
16 shall not impose automobile parking requirements for streamlined developments approved
17 pursuant to this section that exceed one parking space per unit." (§ 65913.4, subd. (d)(2).) And
18 for projects meeting certain criteria—such as projects within one-half mile of transit—no parking
19 requirements may be imposed. (§ 65913.4, subd. (d)(1).) Consequently, the City not only failed
20 to identify the purported parking requirement but also failed to account for the prohibitions in
21 section 65913.4, subdivision (d) as well. Moreover, the City has yet to identify any evidence in
22 the record to support the conclusion that it could require more parking based on the location and
23 characteristics of the project here.

24 As for ingress and egress, "adequacy" is not an objective standard that may be applied to
25 streamlined projects. Objective standards are those "that involve no personal or subjective
26 judgment by a public official and are uniformly verifiable by reference to an external and
27 uniform benchmark or criterion available and knowable by both the development applicant or
28 proponent and the public official before submittal." (§ 65913.4, subd. (a)(5).) What qualifies as

1 adequate—in the absence of an identifiable standard or definition—is simply a matter of
2 personal or subjective judgment. To date, the City has not identified a uniformly verifiable,
3 knowable standard for adequate ingress and egress. Accordingly, it impermissibly relied on a
4 subjective standard in its denial letter.

5 What’s more, there is no explanation in the denial letter about how the proposal was
6 inconsistent with the unspecified standards applied by the City. For example, the City did not
7 explain that the project provided only X number of parking spaces when the required number
8 was Y. So, the City’s denial letter was not code-compliant in this regard as well.

9 The City does not present a convincing argument to support a contrary conclusion. In the
10 City’s papers, it does not clearly and directly counter petitioners’ supporting points. For example,
11 the City does not argue that it adequately identified all of the objective standards set forth in its
12 denial letter or that all of the standards it identified qualified as objective standards permissibly
13 applied in the course of streamlined review. And the City does not explain how its cursory
14 reference to such standards qualified as “an explanation for the reason or reasons the
15 development conflicts with that standard or standards.” (§ 65913.4, subd. (b)(1).)¹⁷ Instead, the
16 City argues the denial letter, when read in conjunction with the incomplete notice, put Developer
17 on sufficient notice so as to somehow satisfy section 65913.4. This argument lacks merit.

18 The first problem with the City’s contention is that it relies on an unspecified standard for
19 the sufficiency of notice in lieu of the standard spelled out by the Legislature in section 65913.4,
20 subdivision (b)(1). Although not clearly articulated by the City, it seems to invoke the concept of
21 notice in the context of the constitutional minimum for procedural due process. (See generally
22 *Gilbert v. City of Sunnyvale* (2005) 130 Cal.App.4th 1264, 1275–1280.) But the issue here is not
23 whether the City met the constitutional minimum. The issue is whether it complied with the
24 applicable statutory requirements.

25
26 ¹⁷ Section 65913.4 does not merely require a statement of reasons for denying an
27 application for streamlined review. Rather, it imposes the more specific requirement of an
28 explanation of how the proposed development conflicts with the objective standards that the
municipality identifies.

1 The City does not advance a persuasive argument for disregarding the specific statutory
2 requirements for notice. While it purports to invoke a principle of statutory construction that
3 places substance over form, it is not necessary to rely on, and the City does not fairly interpret
4 and rely on, that principle. (See generally *Troyk v. Farmers Group, Inc.* (2009) 171 Cal.App.4th
5 1305, 1332 [discussing scope and limitations of concept of substantial compliance].) In actuality,
6 the City urges a complete disregard for the language of the statute in a vacuum and without
7 regard for the statute’s purpose. In other words, the City disregards the form and the substance of
8 the statute. The language the City asks the Court to ignore—what it suggests is a mere
9 formality—is in fact the specific procedure at the heart of the statute that effectuates its purpose.
10 In the absence of deemed compliance under section 65913.4, subdivision (b), the statute would
11 operate as a mere suggestion without an enforcement mechanism. And, because section 65913.4,
12 subdivision (b) is consistent with and effectuates the purpose of the statute, there is no
13 inconsistency between that “form” and the substance of the statute necessitating a reconciliation
14 of those concepts under the canon invoked by the City. The City’s argument in this regard is
15 questionable and its reliance on *County of Kern v. TCEF, Inc.* (2016) 246 Cal.App.4th 301 is
16 misplaced. The Court applies the requirements for a notice of inconsistency that are plainly
17 spelled out in the statute, not an amorphous due process standard that would do violence to its
18 very language and purpose.

19 The second problem with the City’s argument is that it relies on an implausible and
20 unreasonable interpretation of the record. The City states that its incomplete notice and denial
21 letter provide sufficient documentation when read together. But the terms of these documents do
22 not support such a construction. The City explicitly stated that it was proceeding as though it had
23 *two* applications submitted by Developer in November 2018. It purported to deny one application
24 and find the other incomplete. The correspondence setting forth those distinct decisions, while
25 issued together, cannot be fairly read and interpreted in the manner the City now urges. The
26 incomplete notice does not purport to specify inconsistencies with objective standards under SB
27 35; it purports to specify the additional information required before a traditional, *discretionary*
28 *review* could be commenced. Similarly, the denial letter does not purport to require additional

1 information so an SB 35 determination could be made; the letter purports to finally reject the
2 streamlining application upon completion of the City's review. And so, the City's own belief that
3 there were two applications and the unequivocal statements in each discrete item of
4 correspondence purporting to separately dispose of each application cannot fairly be read
5 together as one, code-compliant letter documenting inconsistencies with objective standards
6 under section 65913.4, subdivision (b)(1). The City's post-hoc, revisionist interpretation lacks
7 credibility.¹⁸

8 The City explicitly represented that it had made a decision to deny the streamlining
9 application. Because of this, it cannot now claim that, in fact, it did not make such a decision and
10 lacked sufficient information to do so, all to avoid the consequences of the inadequate notice of
11 inconsistency it had provided. And, even if it could take this inconsistent position, it fails to
12 substantiate the same. The City cites no authority for the proposition that it may evade the
13 statutory deadlines in section 65913.4 by claiming incompleteness. In actuality, it appears the
14 Legislature enacted section 65913.4, in part, to address the use of such delay tactics under
15 existing law:

16 [T]he 1977 Permit Streamlining Act requires public agencies to act
17 fairly and promptly on applications for development permits,
18 including new housing. If they don't, the project is deemed
19 approved. Under the act, public agencies must compile lists of
20 information that applicants must provide and explain the criteria
21 they will use to review permit applications. Public agencies have
22 30 days to determine whether applications for development
23 projects are complete; failure to act results in an application being
24 "deemed complete." However, local governments may continue to
25 request additional information, potentially extending the time
26 before the application is considered complete, which is the trigger
27 for the approval timeline to commence. This has led to the Permit

28 ¹⁸ The Court also finds unpersuasive the City's assertion that Developer somehow created
29 confusion over its application based on the cover sheet it used. (Opp. at p. 9:20-28.) The City
30 had not updated its cover sheet to account for streamlining applications and does not point to any
31 evidence in the record that it had created and made available a separate form or cover sheet for
32 them. Thus, under the circumstances and given the explicit and clear statements in the
33 application itself about the nature of the review Developer was requesting, this assertion and
34 characterization by the City also lacks credibility.

1 Streamlining Act to be characterized as a “paper tiger” that rarely
2 results in accelerated development approvals.

3 (Sen. Gov. & Finance Com., Rep. on Sen. Bill No. 35 (2017–2018 Reg. Sess.) April 26, 2017.)

4 Arguably, if the City had truly lacked sufficient information on which to make an SB 35
5 determination, it could have endeavored to follow section 65913.4 in stating as much by
6 identifying the objective standards that it was applying and explaining how it could not conclude,
7 or lacked sufficient information to conclude, that the project was consistent with those standards.

8 Furthermore, the City does not present reasoned analysis to support the conclusion that a
9 reasonable person simply could not find that the project was consistent with objective standards
10 without all of the information set forth in the notice of incomplete application. The bullet points
11 at page 23 of the City’s opposition do not cure the gaps in its analysis or appear, on their face, to
12 encompass objective standards.

13 In sum, the City does not establish that it properly concluded that Developer’s application
14 was incomplete as a matter of law or fact (e.g., the contents of the denial letter). The City
15 unequivocally denied the streamlining application and will be held to the reasons articulated in
16 its denial letter.

17 For all of these reasons, petitioners show and the City does not effectively refute that it
18 did not provide a code-compliant notice of inconsistency. This conclusion is corroborated by the
19 opinion of HCD. (See AR1330; see also Pet. Supp. RJN.) It follows under section 65913.4 that
20 Developer’s proposal was deemed to comply with objective standards as a matter of law and
21 irrespective of whether the proposal is consistent with those standards as a matter of fact. The
22 City’s points on whether the proposal was, in fact, inconsistent are immaterial, particularly to the
23 extent the City addresses purported inconsistencies other than those identified in the denial letter
24 and within the statutory timeframe for notice.¹⁹ (Opp. at pp. 24:9–27:18.)

25
26 ¹⁹ Because of the essential statutory deadlines in section 65913.4, the Court does not
27 address the City’s belated and post-hoc rationales in detail. That said, petitioners present a
28 number of cogent points about the legal and factual illegitimacy of these belated rationales (Pet.
Brief at pp. 27:6–33:1), which points the City largely fails to address in opposition (Opp. at
pp. 24:21–29:2).

2. Density Bonus Law

“In 1979, the Legislature enacted the density bonus law, section 65915, which aims to address the shortage of affordable housing in California.” (*Latinos Unidos del Valle de Napa y Solano v. County of Napa* (2013) 217 Cal.App.4th 1160, 1164 (*Latinos Unidos*)). “Although application of the statute can be complicated, its aim is fairly simple: When a developer agrees to construct a certain percentage of the units in a housing development for low or very low income households, or to construct a senior citizen housing development, the city or county must grant the developer one or more itemized concessions and a ‘density bonus,’ which allows the developer to increase the density of the development by a certain percentage above the maximum allowable limit under local zoning law.” (*Lagoon Valley, supra*, 154 Cal.App.4th at p. 824, citing § 65915, subds. (a), (b).) “In other words, the Density Bonus Law ‘reward[s] a developer who agrees to build a certain percentage of low-income housing with the opportunity to build more residences than would otherwise be permitted by the applicable local regulations.’ [Citation.]”²⁶ (*Lagoon Valley, supra*, 154 Cal.App.4th at p. 824.)

“To ensure compliance with section 65915, local governments are required to adopt an ordinance establishing procedures for implementing the directives of the statute.” (*Latinos Unidos, supra*, 217 Cal.App.4th at p. 1164, citing § 65915, subd. (a).) The general rule is that a city’s density-bonus ordinance must be consistent with the statewide Density Bonus Law and is preempted to the extent it conflicts. (*Lagoon Valley, supra*, 154 Cal.App.4th at p. 830.) That said, while the Density Bonus Law establishes the minimum bonuses and incentives a municipality is required to provide, the law does not preempt a municipality from providing greater bonuses or incentives in its own ordinance. (*Id.* at pp. 825–826.) Additionally, a density-bonus ordinance must establish a procedure and timeline for evaluating density-bonus requests that is consistent with the Density Bonus Law, including by enumerating the documents and

²⁶ In the event of an inconsistency between the maximum density allowed under the zoning ordinance and the general plan, the general plan controls and provides the limit used to calculate (using the specified bonus percentage) the number of bonus units that may be built. (*Wollmer v. City of Berkeley* (2011) 193 Cal.App.4th 1329, 1344–1345 (*Wollmer II*)).

1 information that must be submitted as part of a complete request. (§ 65915, subds. (a)(2)–(3).) In
2 codifying a transparent and expeditious procedure, a municipality “shall not condition the
3 submission, review, or approval of an application [for a density bonus] on the preparation of an
4 additional report or study that is not otherwise required by state law, including [the Density
5 Bonus Law].” (§ 65915, subd. (a)(2).)

6 The City’s density-bonus ordinance is codified in Los Altos Municipal Code section
7 14.28.040. Under section 14.28.040, subdivision (C)(1)(a)(i) of the City’s code, a development
8 with 10 percent of its units designated for low-income households “shall be granted” a 20
9 percent density bonus. This density bonus increases by 1.5 percent, up to a maximum of 35
10 percent, for each additional percentage point of low-income housing provided. So, for example, a
11 development with 11 percent of its units designated for low-income households is entitled to a
12 21.5 percent density bonus. As relevant here, a development with 20 percent or more units
13 designated for low-income households will be granted the maximum, 35 percent density bonus.
14 That density bonus is calculated as a percent “increase over the otherwise maximum allowable
15 gross residential density” (Los Altos Mun. Code, § 14.28.040, subd. (B)(2); see also
16 § 65915, subd. (f).)

17 A developer may additionally obtain an incentive for designating units for low-income
18 households. (Los Altos Mun. Code, § 14.28.040, subd. (C)(1)(a)(ii).) A developer must be
19 granted one incentive for designating 10 percent of units for low-income households, two
20 incentives for designating 20 percent, and three incentives for designating 30 percent or more.
21 (*Ibid.*; see also § 65915, subd. (d)(2)(A)–(C).) The City has codified “on-menu incentives”—
22 incentives that “would not have a specific adverse impact”—in the density-bonus ordinance.
23 (Los Altos Mun. Code, § 14.28.040, subd. (F).)

24 A city “shall grant” a bonus or incentive unless it makes written findings supported by
25 substantial evidence that: there will be no identifiable and actual cost reduction to provide for
26 affordable housing costs; there will be a specific, adverse, unmitigable impact on public health
27 and safety, the environment, or registered historic places; or granting the bonus or incentive is
28 contrary to state or federal law. (§ 65915, subd. (d)(1); see also Los Altos Mun. Code,

1 § 14.28.040, subd. (F)(3).) And, “[i]n no case may a city ... apply any development standard that
2 will have the effect of physically precluding the construction of a development meeting the
3 criteria of subdivision (b) at the densities or with the concessions or incentives permitted by [the
4 Density Bonus Law].” (§ 65915, subd. (e)(1).) A developer may seek a waiver or reduction of
5 such standards that physically impede construction of the development. (*Ibid.*)

6 “The applicant may initiate judicial proceedings if the city ... refuses to grant a requested
7 density bonus, incentive, or concession.” (§ 65915, subd. (d)(3).) As noted, this proceeding is
8 ordinarily brought in administrative mandamus. (See, e.g., *Lagoon Valley, supra*,
9 154 Cal.App.4th at pp. 812, 816–817.) The city “shall bear the burden of proof for the denial of a
10 requested concession or incentive.” (§ 65915, subd. (d)(4).) “If a court finds that the refusal to
11 grant a requested density bonus, incentive, or concession is in violation of this section, the court
12 shall award the plaintiff reasonable attorney’s fees and costs of suit.” (§ 65915, subd. (d)(3).)

13 In Developer’s application (inclusive of its density bonus report), it proposed designating
14 two of eight base units—i.e. 25 percent of the base units—for low-income households.
15 (AR000010, AR000061.) Developer asserted that this level of affordability entitled it to: 1) a 35
16 percent density bonus; and 2) two concessions, only one of which it sought to use. (AR000010,
17 AR000061.) Developer selected an 11-foot height increase—which is on-menu (Los Altos Mun.
18 Code, § 14.28.040, subd. (F)(1)(d))—as its concession. (AR000010, AR000061.) Based on the
19 bonus and concession, Developer proposed constructing seven additional units. (AR000061).²¹ It
20

21 ²¹ Consistently with state law, the Los Altos Municipal Code defines a density bonus as
22 an “increase over the otherwise maximum allowable gross residential density” (Los Altos
23 Mun. Code, § 14.28.040, subd. (B)(2); see also § 65915, subd. (f).) The maximum allowable
24 density means the density allowed under a local zoning ordinance or general plan, with the
25 maximum density in the general plan controlling in the event of an inconsistency. (§ 65915,
26 subd. (o)(2); see also *Lagoon Valley, supra*, 154 Cal.App.4th at p. 824.) Developer asserts and
27 the City does not seem to dispute that there is no standard for units or intensity (Floor Area
28 Ratio) applicable to buildings, like the proposed development, that are zoned Commercial-Retail
Sales/Office-Administrative District (CRS/OAD). (AR000011, AR000062 [Density Bonus
Report].) Perhaps there is no standard because housing above the ground floor qualifies as a
conditionally-permitted use under Los Altos Municipal Code section 14.54.040 as compared to
an office or retail use that is permitted by right under section 14.54.030. In any event, instead of
applying the density bonus to the maximum density allowed under the law (either the ordinance

1 appears the seven units exceed the number authorized by the 35 percent density bonus standing
2 alone, so the parties' dispute seems to hinge on whether the right to an 11-foot height increase
3 necessarily includes the right to include additional housing units in that additional space. (See
4 AR002310-AR002311.)

5 As a threshold matter, the City's interpretation of the Density Bonus Law is incorrect.
6 The City asserts that any and all concessions, incentives, and waivers must result—
7 collectively—in no more than a 35 percent increase in density. Courts have routinely rejected
8 such an interpretation of the law. The 35 percent bonus authorized under the Density Bonus Law
9 and the City's own ordinance is the mandatory minimum a city must provide; it is not a cap.
10 (*Laguna Valley, supra*, 154 Cal App.4th at pp. 823–826.) And so, the City was required, at
11 minimum, to provide a 35 percent bonus and any other incentive or concession required by law.
12 Otherwise, to the extent the City believed any additional incentive or concession was
13 discretionary, it was required to inform Developer of this conclusion in a code-compliant manner
14 by making the statutorily required findings. (See § 65915, subd. (d)(1); see also Los Altos Mun.
15 Code, § 14.28.040, subd. (F)(3).) The City failed to do so here. Instead, the City made a vague
16 statement that “the requested concessions and waivers appear to raise substantial issues
17 concerning public health and safety, including questions regarding” compliance with the
18 Americans With Disabilities Act (42 U.S.C. § 12101 et seq.). (AR002311.) On its face, this
19 statement is so equivocal as to fall short of an affirmative finding. Furthermore, this statement
20 does not identify a specific, adverse, unmitigable impact on public health and safety.
21 Accordingly, this finding is deficient.

22 To be sure, although the City bears the burden of justifying its density-bonus decision, it
23 does not attempt to justify that decision under an appropriate standard of review and based on the
24 statutory requirements. Its opposition instead focuses on its interpretation of the 35 percent bonus

25
26
27 _____
28 or the general plan). Both parties appear, at times, to treat the bonus as applying to the number of
base units. (See, e.g., AR002310-AR002311.)

1 as a cap, which interpretation is contrary to established precedent. Accordingly, petitioners'
2 density-bonus claim is meritorious; the City did not comply with the law.

3 In reaching this conclusion, the Court notes that it remains unsettled whether the City
4 could attempt to deny the density-bonus request for the first time during the administrative
5 proceeding. This is because section 65913.4 contemplates that a proposal subject to streamlined
6 review may contain bonus units. (§ 63913.4, subd. (a)(2)(C).) Arguably, to determine whether a
7 project with bonus units comports with the objective standards in section 65913.4, a city must
8 determine whether the bonus units are allowable in the course of a streamlined review. In
9 truncating the review process through section 65913.4, the Legislature has not clearly addressed
10 how such changes operate with other housing laws, such as the Density Bonus Law. Ultimately,
11 because even the City's final resolution is deficient, the Court does not and need not resolve this
12 question.

13 In concluding that the City violated the Density Bonus Law, the Court rejects the City's
14 argument that Developer's application was incomplete or lacked sufficient information to allow
15 it to evaluate the density-bonus request.

16 "A local government shall not condition the submission, review, or approval of an
17 application pursuant to this chapter on the preparation of an additional report or study that is not
18 otherwise required by state law, including this section." (§ 65915, subd. (a)(2).) This prohibition
19 does not preclude a municipality from requiring "reasonable documentation to establish
20 eligibility for a requested density bonus" (*Ibid.*) But, a municipality "shall ... [p]rovide a list
21 of all documents and information required to be submitted with the density bonus application in
22 order for the density bonus application to be deemed complete." (§ 65915, subd. (a)(3)(B).)
23 "This list shall be consistent with this chapter." (*Ibid.*)

24 Collectively, these directives and prohibitions establish that a municipality cannot
25 condition consideration and approval of a density-bonus request on information or documents
26 unless it specifies these materials in advance and in conformity with the Density Bonus Law.

27 Here, Los Altos Municipal Code 14.28.040, subdivision (D) specifies the local forms and
28 other information an applicant must submit with a density-bonus request. That said, with the

1 exception of several forms, the ordinance broadly requires “reasonable documentation” of certain
2 facts and does not specify particular documents that must be submitted. (Los Altos Mun. Code,
3 § 14.28.040, subd. (D).) In the City’s opposition, it offers a conclusory assertion that Developer’s
4 application was incomplete. The City does not explain how its application requirements comport
5 with those permitted under the Density Bonus Law. And the City does not attempt to justify the
6 sufficiency of its findings or the evidence on the subject of completeness. This presentation is
7 insufficient to carry the City’s burden of establishing that it complied with the law.

8 Looking to the City’s final resolution and the notice of incomplete application referenced
9 therein, and assuming for argument sake that this notice could be considered as part of the City’s
10 denial of the streamlined application, the propriety of the City’s conduct is not apparent. The
11 “Density Bonus Report Submittal Requirements”—a form that accompanied the notice of
12 incomplete application—indicates that Developer had largely submitted all required information.
13 (AR000147–AR000149.) Based on circling and underlining on the second page of this form, the
14 City seemed to take the position that it needed additional documentation that incentives or
15 concessions would result in cost reductions and that waivers were needed for standards that
16 would physically preclude the concessions or incentives. (AR000148.) Because the Density
17 Bonus Law now puts the onus on a municipality to make a finding to support denial of a density-
18 bonus request, such as a finding that a concession or incentive would not result in cost reductions
19 (§ 65915, subd. (d)(1)(A)), the City’s insistence that Developer prove the contrary in the first
20 instance shifts the burden to the applicant in contravention of the statute.²² And, also, the
21 requested “reasonable documentation” appears to concern matters beyond the eligibility
22 information that can be requested. (§ 65915, subd. (a)(2).) Moreover, Developer asserts that the
23 City is incorrect because Developer did, in fact, submit sufficient information. This assertion is
24 correct. The claim that the City could not determine the allowable base density is not credible
25

26 ²² The record reflects that the City sought out a consultant but apparently never hired one
27 or completed the process required to evaluate and make findings sufficient to reject Developer’s
28 density-bonus request. (See AR002332–AR002336 [proposed scope of work from Keyser
Marston Associates].)

1 given that density is determined by municipal law. And, as for eligibility, Developer otherwise
2 presented detailed information in its application about its building plans to allow the City to
3 evaluate eligibility for a density-bonus. The City did not rebut this point in its papers or at the
4 hearing. To summarize, even setting aside the City's inadequate argument and analysis on the
5 Density Bonus Law, the record undercuts any claim of incompleteness based on what a city may
6 legally ask for and what Developer, in fact, presented here.

7 3. *Housing Accountability Act*

8 The Housing Accountability Act or "HAA (§ 65589.5), known as the 'anti-NIMBY law,'
9 was designed to limit the ability of local governments to reject or render infeasible housing
10 developments based on their density without a thorough analysis of the 'economic, social, and
11 environmental effects of the action ...' (§ 65589.5, subd. (b).)" (*Katnel Gardens, LLC v. City of*
12 *Los Angeles* (2016) 3 Cal.App.5th 927, 938 (*Katnel Gardens*)). "When a proposed development
13 complies with objective general plan and zoning standards, including design review standards, a
14 local agency that intends to disapprove the project, or approve it on the condition that it be
15 developed at a lower density, must make written findings based on [a preponderance of the
16 evidence on the record] that the project would have a specific, adverse impact on the public
17 health or safety and that there are no feasible methods to mitigate or avoid those impacts other
18 than disapproval of the project. (§ 65589.5, subd. (j)(1).)"²³ (*Katnel Gardens, supra*,
19 3 Cal.App.4th at pp. 938–939.) And, much like the streamlining statute (§ 65913.4), the HAA
20 requires written notice of inconsistency within 30 or 60 days and provides that if an agency "fails
21 to provide the required documentation pursuant to subparagraph (A), the housing development
22 project shall be deemed consistent, compliant, and in conformity with the applicable plan,
23 program, policy, ordinance, standard, requirement, or other similar provision." (§ 65589.5,
24 subd. (j)(2).)

25
26
27 ²³ Until December 31, 2017, section 65589.5 required that an agency's findings be
28 supported only by substantial evidence. Effective January 1, 2018, the findings must be
supported by a preponderance of the evidence. (Sen. Bill No. 167 (2017–2018 Reg. Sess.) § 1
[Stats. 2017, ch. 368]; Assem. Bill No. 678 (2017–2018 Reg. Sess.) § 1 [Stats. 2017, ch. 373].)

1 If an agency fails to comply with the HAA, a developer, prospective resident, or housing
2 organization, such as Renters here, may seek judicial review by filing a petition for writ of
3 administrative mandate. (*Kalnel Gardens, supra*, 3 Cal.App.5th at p. 941, citing § 65589.5,
4 subd. (m).) Under that judicial review, section 65589.5, subdivision (i) explicitly places the
5 burden of proof on the agency to “show that its decision is consistent with the findings as
6 described in subdivision (d), and that the findings are supported by a preponderance of the
7 evidence in the record with the requirements of subdivision (o).”²⁴ If an agency “disapproved a
8 project or conditioned its approval in a manner rendering it infeasible” without making the
9 required findings, the court must issue an order or judgment compelling the jurisdiction to
10 comply within 60 days, including by taking action on the development. (§ 65589.5, subd. (k).)
11 “The court may issue an order or judgment directing the local agency to approve the housing
12 development project or emergency shelter if the court finds that the local agency acted in bad
13 faith²⁵ when it disapproved ... the housing development or emergency shelter in violation of this
14 section.” (§ 65589.5, subd. (k)(1)(A)(ii).) “The court shall retain jurisdiction to ensure that its
15 order or judgment is carried out and shall award reasonable attorney’s fees and costs of suit to
16 the plaintiff or petitioner, except under extraordinary circumstances in which the court finds that
17 awarding fees would not further the purposes of this section.” (§ 65589.5, subd. (k)(1)(A).)

18 The City here fails to carry its burden of establishing compliance with the HAA. For the
19 reasons articulated above, its claim of incompleteness of Developer’s SB 35 application is not
20 persuasive. The City does not provide reasoned legal analysis to support the conclusion that the
21 application was incomplete within the meaning of the HAA. And for the reasons previously
22 articulated with respect to section 65913.4, the City also did not provide a code-compliant notice
23 of inconsistency under section 65589.5. And even in the final resolution adopted by the City
24

25 ²⁴ This standard is similar to the abuse of discretion standard ordinarily applicable in all
26 manner of administrative mandamus proceedings. (See *Kalnel Gardens, supra*, 3 Cal.App.5th at
27 p. 937, citing Code Civ. Proc., § 1094.5, subd. (b).)

28 ²⁵ “For purposes of this section, ‘bad faith’ includes, but is not limited to, an action that is
frivolous or otherwise entirely without merit.” (§ 65589.5, subd. (l).)

1 Council, the City did not make statutorily required findings sufficient to reject or require
2 modification of the project under the HAA. Accordingly, the City also does not establish that it
3 complied with the HAA.

4 In reaching this conclusion, the Court further finds that the City acted in bad faith as
5 defined in the HAA because its denial was entirely without merit. The City's denial letter and the
6 record before the Court do not reflect that the City made a benign error in the course of
7 attempting, in good faith, to follow the law by timely explaining to Developer just how its
8 project conflicted with objective standards in existence at the time or by trying to make findings
9 that resemble what the law requires. Instead, in addition to tactics such as demanding an
10 administrative appeal on less than one day's notice and using strained constructions and textual
11 interpretations to assert that Developer had presented two applications that had to be withdrawn,
12 the City denied the streamlining application with a facially deficient letter and later adopted a
13 resolution enumerating insufficient reasons for the denial. So, in addition to the fact that section
14 65913.4 warrants a writ directing the City to issue the permit, its conduct justifies the same relief
15 under section 65589.5, subdivision (k)(1)(A) as well.

16 *C. Scope of Relief*

17 Because the Court concludes that the City violated section 65913.4, the Density Bonus
18 Law, and the HAA, petitioners are entitled to writ relief. Nevertheless, the parties dispute and
19 addressed in supplemental briefing the nature and scope of relief that should be awarded.
20 Petitioners ask the Court to provide relief under all three statutes, while the City argues the Court
21 should solely order relief under section 65913.4 because additional statutory relief is duplicative.
22 While the Court agrees that there is some overlap in the relief afforded by each separately
23 applicable statute and that all three statutes warrant the same substantive outcome—affording
24 relief in mandate—the Court rejects the City's claim that the relief afforded by each statute is
25 entirely duplicative. For example, as the City acknowledges, the Density Bonus Law and HAA
26 authorize an award of attorney fees and costs. Even accepting the City's suggestion that the
27 Court fix the amount of such fees and costs at a later date, this fact does not obviate the need for
28 the Court to rule on these statutory bases as a prerequisite for a later motion for attorney fees

1 under either statute. Also, the HAA gives the Court continuing jurisdiction over statutory
2 enforcement mechanisms, which may include fines for noncompliance. The additional remedies
3 for enforcing the HAA are not duplicative. And, arguably, the Court must award relief under the
4 HAA now as a prerequisite for any later enforcement measures that may be necessary even
5 accepting, as the City points out, that the time for such enforcement has yet to arrive. Ultimately,
6 the City does not identify any legal basis for refusing to grant relief under all three statutes. For
7 these reasons, the Court accepts petitioners' argument that relief under each statute is warranted.

8 The Court holds that Developer's project was deemed to comply with applicable
9 standards under SB 35 and that the City must rescind its decision to deny and instead approve
10 and permit the project at the requested density. The parties agree that this directive to rescind the
11 existing decision and permit the project within 60 days, as compared to remanding the matter for
12 further consideration, is the appropriate course of action. (City's Supp. Brief at p. 8.) To the
13 extent petitioners seek relief other than a writ and declaratory judgment, including attorney fees,
14 costs, and additional fines or penalties, the parties agree that such matters will be resolved by
15 post-judgment noticed motion (for attorney fees or to tax costs) and, as for the penalties, further
16 proceedings should they become necessary.

17 Finally, the Court declines to issue a declaratory judgment. It is true that because
18 declaratory relief is a cumulative remedy "a proper complaint for declaratory relief cannot be
19 dismissed by the trial court because the plaintiff could have filed another form of action."
20 (*Californians for Native Salmon Assn. v. Department of Forestry* (1990) 221 Cal.App.3d 1419,
21 1429.) And there is no categorical prohibition on joining a complaint for declaratory relief with a
22 petition for writ of mandate; in appropriate circumstances, this is permissible. (*Gong v. City of*
23 *Fremont* (1967) 250 Cal.App.2d 568, 574.) That said, when challenging an action under Code of
24 Civil Procedure section 1094.5—a decision in a particular instance as compared to a policy or
25 ordinance standing alone—mandamus relief is typically the exclusive remedy and declaratory
26 relief is not additionally available or necessary. (*State of Cal. v. Super. Ct.* (1934) 12 Cal.3d 237,
27 251–252; see also *Selby Realty Co. v. City of San Buenaventura* (1973) 10 Cal.3d 110, 126–127
28 [declaratory relief not proper vehicle for challenging denial of building permit].) In actuality, in a

1 hybrid proceeding, declaratory relief may be sought to test the constitutionality or legality of an
2 ordinance or policy on its face with an accompanying request for a writ of mandate directed to
3 the agency's application of that ordinance or policy to the petitioner in particular. (*Gong, supra*,
4 250 Cal.App.2d at p. 574.) Here, petitioners do not seek a declaration of the validity of the City's
5 policies, interpretation of the law, or zoning ordinance; rather, they seek a declaratory judgment
6 stating the City must issue the streamlined permit Developer applied for.²⁶ In other words, they
7 simply seek a duplicative declaration requiring the City to perform its duty and issue the permit.
8 The problem is not simply that the declaratory relief requested is duplicative, but rather, that the
9 relief sought is a proper subject of mandamus and it does not encompass a question of validity or
10 constitutionality that typically warrants additional declaratory relief in a mandamus proceeding.
11 Accordingly, the Court exercises its discretion under Code of Civil Procedure section 1061 and
12 declines to provide declaratory relief that would be duplicative of that already being provided in
13 mandate.

14 *IV. Conclusion*

15 The petitions for writ of mandate are granted, and judgment will be entered consistently
16 with this Order. Petitioners are prevailing parties for purposes of costs of suit under Code of
17 Civil Procedure section 1032, which costs would be claimed post-judgment by timely filed
18 memoranda and which are subject to striking and taxing according to law. The judgment to be
19 entered will direct the issuance of a peremptory writ of mandate commanding the relief
20 contemplated in this Order and consistently with its analysis and conclusions. Counsel for
21 petitioners have already collectively proposed a form of judgment and a form of writ to be
22 issued, which they submitted with their post-hearing briefing. Counsel for petitioners are directed
23 to provide those separate documents to the Court in Word format by email to
24 Department10@scscourt.org within 10 days of service of this Order, with copy to counsel for the
25 City. Counsel for the City is to submit any objections as to the form of the proposed judgment
26

27
28 ²⁶ The Court notes that in Petitioners' supplemental brief on the scope of relief and in their proposed judgment, they elaborate on the declaratory relief sought in their pleadings.

1 and proposed writ within 20 days from service of this Order, with courtesy copy to the Court at
2 the same email address and copy to counsel for petitioners.

3
4 IT IS SO ORDERED.

5
6 Date: April 24 2020

7
8 _____
HELEN E. WILLIAMS
Judge of the Superior Court



EXECUTIVE SUMMARY CONDITIONAL USE

HEARING DATE: March 25, 2021

Record No.: 2019-020740CUA
Project Address: 468 Turk Street
Zoning: RC-4 (Residential – Commercial, High Density) Zoning District
80-T Height and Bulk District
North of Market Residential 1 Special Use District
Block/Lot: 0336/006
Project Sponsor: Mark Macy
315 Linden Street
San Francisco, CA 94103
Property Owner: Turk Street, LLC
8 Dellbrook Ave
San Francisco, CA 94131
Staff Contact: Claudine Asbagh – (628) 652-7329
claudine.asbagh@sfgov.org

Recommendation: Approval with Conditions

Project Description

The Project includes demolition of the existing two-story mixed-use building and new construction of a nine-story-over basement, 86-ft tall, residential building (approximately 35,090 square feet (sq. ft.)) with 101 group housing units, 45 Class 1 bicycle parking spaces, and 6 Class 2 bicycle parking spaces.

Pursuant to California Government Code Section 65400, and 65915-65918 as revised under AB2345, the Project Sponsor has elected to utilize the State Density Bonus Law and has requested waivers from the Planning Code volumetric requirements for: Height (Planning Code Section 260) Upper Story Setback (Planning Code Section 132.2), and Rear Yard (Planning Code Section 134). The base project includes 67 units and the Project is seeking a density bonus of 50% for a total of 101 group housing units. 25% of the base project, or 17 units, will be affordable. Ten of the units (15%) will be affordable to very low-income (50% AMI) households, three of the units (5%) will be

affordable to low-income (80% AMI) households, and the remaining four (5%) will be affordable to moderate-income households as defined by the Planning Code and Procedures Manual.

Required Commission Action

In order for the Project to proceed, the Commission must grant a Conditional Use Authorization, pursuant to Planning Code Sections 209.3, 253 and 303 to allow the construction of a building that exceeds 50 feet in height at the street frontage within the RM-4 (Residential – Commercial, High Density) Zoning District and 80-T Height and Bulk District. The Commission must also make findings related to the waivers from development standards for the Height (Section 260) Upper Story Setback (Section 132.2), and Rear Yard (Section 134) pursuant to State Density Bonus Law and Planning Code Section 206.6.

Issues and Other Considerations

- **Public Comment & Outreach.**
 - **Support/Opposition:** The Department has received three emails in opposition to the Project from a nearby neighbor and two employees of the adjacent property at 440 Turk Street. Opposition to the Project is centered on:
 - The lack of existing essential services such as grocery stores for the surrounding community;
 - Concerns about impacts of the construction noise and pollution on the residents of the adjacent senior housing facility at 440 Turk Street and reduction of their access to sunlight at the existing roof deck;
 - Concerns of gentrification and over-densification of the area.
 - **Outreach:** The Sponsor held a pre-application meeting on October 30, 2019, and attended one meeting with the Tenderloin Housing Clinic Landuse Committee on February 23, 2021. The Tenderloin Housing Clinic and Tenderloin Neighborhood Development Corporation have both encouraged that the project include family-sized units, as the immediate area contains a high saturation of SROs, student housing, and other group housing models.
- **Affordable Housing:** The Environmental Evaluation Application was accepted on November 4, 2019; therefore, pursuant to Planning Code Section 415.3, the Inclusionary Affordable Housing Program requirements for the On-Site Affordable Housing Alternative is to provide a minimum of 25% of the total base project as affordable. The on-site inclusionary rate is broken into three separate income tiers: 15% of the units must be made available to very-low-income households, at 50% AMI, 5% must be made available to low-income households at 80% AMI, and 5% must be made available to moderate-income households at 110% AMI. The Sponsor may use their on-site inclusionary units to qualify for a density bonus under the State Density Bonus Law.
- **State Density Bonus Law:** The Project is invoking the California State Density Bonus (California Government Code Sections 65400 and 65915-65918, as amended under AB-2345) to increase the development capacity of the site. As such, the Project is required to provide on-site below market rate units, pursuant to Planning Code Section 415, for the base project (portion of the development permissible under existing zoning), and can elect

to do on-site below market rate units or pay fees for units and floor area gained by the density bonus. Per the submitted Inclusionary Housing Affidavit, the Project Sponsor is providing 17 below market rate dwelling units on-site (25% of the base density). The inclusion of 15% of the 67 base density units below 50% AMI allows for a density bonus of 50%, or 34 units for a total of 101 group housing units.

Under the State Density Bonus Law, the Project is seeking waivers from development standards for the Height (Section 260) Upper Story Setback (Section 132.2), and Rear Yard (Section 134). No concessions are being sought.

Environmental Review

On October 20, 2020, the Project was determined to be exempt from the California Environmental Quality Act (“CEQA”) as a Class 32 Categorical Exemption under CEQA as described in the determination contained in the Planning Department files for this Project.

Basis for Recommendation

The Department finds that the Project is, on balance, consistent with the Objectives and Policies of the General Plan. The Project proposes a substantial amount of new rental housing, including new on-site below-market rate units for rent. The Department also finds the project to be necessary, desirable, and compatible with the surrounding neighborhood, and not to be detrimental to persons or adjacent properties in the vicinity.

Attachments:

- Draft Motion – Conditional Use Authorization with Conditions of Approval
- Exhibit B – Plans and Renderings
- Exhibit C – Environmental Determination
- Exhibit D – Land Use Data
- Exhibit E – Maps and Context Photos
- Exhibit F – Inclusionary Affordable Housing Affidavit
- Exhibit G – Anti-Discriminatory Housing Affidavit
- Exhibit H – First Source Hiring Affidavit



PLANNING COMMISSION DRAFT MOTION

HEARING DATE: March 25, 2021

Record No.: 2019-020740CUA
Project Address: 468 Turk Street
Zoning: RC-4 (Residential – Commercial, High Density) Zoning District
80-T Height and Bulk District
North of Market Residential 1 Special Use District
Block/Lot: 0336/006
Project Sponsor: Mark Macy
315 Linden Street
San Francisco, CA 94103
Property Owner: Turk Street, LLC
8 Dellbrook Ave
San Francisco, CA 94131
Staff Contact: Claudine Asbagh – (628) 652-7329
claudine.asbagh@sfgov.org

ADOPTING FINDINGS: 1) TO APPROVE A CONDITIONAL USE AUTHORIZATION PURSUANT TO PLANNING CODE SECTIONS 209.3, 253 AND 303, TO CONSTRUCT A BUILDING THAT EXCEEDS 50 FEET IN HEIGHT AT THE STREET FRONTAGE, LOCATED AT 468 TURK STREET, LOT 006 IN ASSESSOR'S BLOCK 0336; 2) OF ELIGIBILITY FOR THE INDIVIDUALLY REQUESTED STATE DENSITY BONUS; AND 3) UNDER THE CALIFORNIA ENVIRONMENTAL QUALITY ACT.

THE PROJECT WOULD DEMOLISH THE EXISTING TWO-STORY COMMERCIAL BUILDING AND CONSTRUCT A NINE-STORY, 86-FT TALL, RESIDENTIAL BUILDING (APPROXIMATELY 35,090 SQUARE FEET) WITH 101 GROUP HOUSING UNITS. THE PROJECT WOULD UTILIZE THE STATE DENSITY BONUS LAW (CALIFORNIA GOVERNMENT CODE SECTIONS 65915-65918) AND RECEIVE WAIVERS FROM THE PLANNING CODE REQUIREMENTS FOR: MAXIMUM HEIGHT LIMIT (SECTION 260), MINIMUM UPPER STORY SETBACKS (SECTION 132.2), AND MINIMUM REAR YARD (SECTION 134).

PREAMBLE

On November 19, 2019, Mark Macy of Macy Architecture (hereinafter "Project Sponsor") filed Application No. 2019-020740CUA (hereinafter "Application") with the Planning Department (hereinafter "Department") for a Conditional Use Authorization to construct a new nine-story, 86-ft tall, residential building with 101 Group Housing units (hereinafter "Project") at 468 Turk Street, Block 0336 Lot 006 (hereinafter "Project Site").

The Project Sponsor seeks to proceed under the State Density Bonus Law, Government Code Section 65915 et seq ("the State Law"), as amended under AB-2345. Under the State Law, a housing development that includes affordable housing is entitled to additional density, concessions and incentives, and waivers from development standards that might otherwise preclude the construction of the project. In accordance with the Planning Department's policies regarding projects seeking to proceed under the State Law, the Project Sponsor has provided the Department with "Base Project" including approximately 24,749 square feet of Residential gross floor area that would include housing affordable to very-low income households. Because the Project Sponsor is providing 15% of base project units of housing affordable to very-low income households, the Project seeks a density bonus of 50% and waivers of the following development standards: 1) Height (Planning Code Sections 260); 2) Upper Story Setback (Planning Code Section 132.2); and Rear Yard (Planning Code Section 134).

On March 17, 2021, the Project was issued a Categorical Exemption, Class 32 (California Environmental Quality Act (CEQA) Guidelines Section 15322). Approval of the Conditional Use Authorization by the Planning Commission is the Approval Action for the project. The Approval Action date establishes the start of the 30-day appeal period for this CEQA exemption determination pursuant to Section 31.04(h) of the San Francisco Administrative Code.

On March 25, 2021, the San Francisco Planning Commission (hereinafter "Commission") conducted a duly noticed public hearing at a regularly scheduled meeting on Conditional Use Application No. 2019-020740CUA.

The Planning Department Commission Secretary is the custodian of records; the File for Record No. 2019-020740CUA is located at 49 South Van Ness Avenue, Suite 1400, San Francisco, California.

The Commission has heard and considered the testimony presented to it at the public hearing and has further considered written materials and oral testimony presented on behalf of the applicant, Department staff, and other interested parties.

MOVED, that the Commission hereby authorizes the Conditional Use Authorization as requested in Application No. 2019-020740CUA, subject to the conditions contained in "EXHIBIT A" of this motion, based on the following findings:

FINDINGS

Having reviewed the materials identified in the preamble above, and having heard all testimony and arguments, this Commission finds, concludes, and determines as follows:

- 1. The above recitals are accurate and constitute findings of this Commission.**
- 2. Project Description.** The Project includes demolition of the existing two-story mixed-use building on the project site, and new construction of a nine-story, 86-foot tall, residential building (approximately 36,860 gross square feet) with 101 Group Housing units, 45 Class 1 bicycle parking spaces, and six Class 2 bicycle parking spaces. The Project includes 2,230 square feet of common open space via ground floor courtyard and roof deck, and 3,197 square feet of interior common spaces at the ground floor and mezzanine levels.
- 3. Site Description and Present Use.** The Project is located on a lot with a lot area of approximately 4,667 square feet, and frontage of approximately 58 feet at Turk Street. The Project Site contains a two-story mixed-use building that is presently vacant. The ground floor was historically occupied by restaurants, delis, and markets, and the upper floor was typically occupied by various office uses.
- 4. Surrounding Properties and Neighborhood.** The Project Site is located within the RC-4 Zoning District and North of Market Special Use District Subarea 1, and within the boundaries of the Uptown Tenderloin Historic District, which is listed on the National Register. The immediate context is mixed in character with residential, industrial, and institutional uses. The immediate context is primarily multi-unit residential with neighborhood-serving commercial uses at the ground floor. The immediate vicinity includes buildings ranging from two to eight stories in height. Other zoning districts in the vicinity of the project site include: P (Public), the Lower Polk St NCD (Neighborhood Commercial District), and C-3-G (Downtown-General) Zoning District.
- 5. Public Outreach and Comments.** The Department has received three emails in opposition from members of the public citing the lack of critical services such as grocery stores in the area, concerns about gentrification and over-densification of the immediate neighborhood, and concerns about impacts to the senior residents of the adjacent housing facility at 440 Turk Street. The project sponsor presented for the land use committee of the Tenderloin Housing Clinic on February 23, 2021.
- 6. Planning Code Compliance.** The Commission finds that the Project is consistent with the relevant provisions of the Planning Code in the following manner:
 - A. Use.** Planning Code Section 209.3 principally permits Group Housing uses within the RC-4 Zoning Districts. Group Housing density is limited to one unit per 70 square feet of lot area. Per the State Density Bonus law, revised under AB-2345, if 15% of the Base Density Units are provided at 50% AMI, then a Bonus Density of 50% is permitted.

The subject lot has an area of 4,696 square feet, allowing for a base density of 67 units. The proposal includes 15% of the Base Density Units at 50% AMI, allowing for a bonus of 34 (50% of the Base project) units for a total of 101 Group Housing units.
 - B. Upper Floor Setback.** Within the North of Market Residential Special Use District, Planning Code

Section 132.2 requires a setback of the front façade at 50 feet to maintain continuity of the prevailing streetwall.

The Base Project proposes a setback of approximately 22 feet and complies with Section 132.2 of the Planning Code. The Project proposes a height of 86 feet at the streetwall, which would extend approximately 16 feet above the height of the adjacent property to the west at 500 Larkin Street and minimally above the total height of 440 Turk Street, the adjacent eight-story supportive housing facility constructed circa 1984 located to the immediate east of the Project site.

Per California Government Code Sections 65915-65918, the Project Sponsor has elected to utilize the State Density Bonus Law, and requests a waiver from the development standards for the upper floor setback requirements, which are defined in Planning Code 132.2. Waiving this requirement allows for the proposed increase in density, as provided by Government Code Section 65915.

- C. **Rear yard.** Within the RC-4 Zoning District, Planning Code Section 134 establishes that the minimum rear yard depth shall be equal to 25% of the total lot depth on which the lot is situated but in no case less than 15 feet.

The Project site is 80 feet in depth and therefore requires a minimum rear yard of 20 feet, or 25%. The Project proposes a rear yard depth of 15 feet.

Per California Government Code Sections 65915-65918, the Project Sponsor has elected to utilize the State Density Bonus Law and requests a waiver from the development standards for rear yard requirements, which are defined in Planning Code 134. This reduction of the rear yard depth allows for the proposed increase in density, as provided by Government Code Section 65915.

- D. **Usable Open Space.** Within the RC-4 Zoning District, Planning Code Section 135 requires the Group Housing structures provide one third of the required area of usable open space per dwelling unit, or 16 square feet of common usable open space per Group Housing unit.

The Planning Code requires a total of 1,616 square feet of usable open space for the proposed 1010 Group Housing units. The project proposes 860 square feet of usable open space at the rear courtyard, which meets the minimum area requirements, and 1,370 square feet of open space at the shared roof deck for a total of 2,230 square feet. Therefore, the Project meets the Open Space requirement.

- E. **Dwelling Unit Exposure.** Planning Code Section 140(b) requires that either each Group Housing bedroom or at least one interior common area that meets the 120 square-foot minimum superficial floor area shall include windows that face onto a public street, rear yard or other open area that meets minimum requirements for area and horizontal dimensions.

The project contains 59 units that face the rear yard area, which does not meet the minimum 25-foot dimension requirements per Planning Code Section 140(a)(1); however, the 1,639 square foot common space at the ground floor and mezzanine face onto Turk Street, which does meet the dimension requirements. The remaining 49 units have exposure over Turk Street. Therefore, the Project meets the requirements of Section 140 of the Planning Code.

- F. **Street Frontage in Residential-Commercial Districts.** Planning Code Section 145.1 requires that space for active uses be provided within the first 25 feet of building depth on the ground floor; that non-residential uses have a minimum floor-to-floor height of 14 feet; that the floors of street-fronting interior spaces housing non-residential active uses and lobbies be as close as possible to the level of the adjacent sidewalk at the principal entrance to these spaces; and that frontages with active uses that are not residential be fenestrated with transparent windows and doorways for no less than 60 percent of the street frontage at the ground level.

The Project meets the requirements of Planning Code Section 145.1. The Project features an active common space use at a depth of 28 feet at the ground floor with a height of approximately 18 feet 7 inches (including the glazed mezzanine) adjacent to the front property line that is more than 60% glazed.

- G. **Bicycle Parking** Planning Code Section 155.2 requires at least one Class 1 bicycle parking space for every four beds or, for buildings containing over 100 beds, 25 Class 1 spaces plus one Class 1 space for every five beds over 100. It additionally requires two Class 2 spaces for every 100 beds.

The Project, which includes 202 group housing beds, meets the requirements of Planning Code Section 155.2. The basement level will contain 45 Class 1 bicycle parking spaces and six Class 2 spaces are proposed at the front of the property, although only four are required.

- H. **Height and Bulk.** The project is located in an 80-T Height and Bulk District, which allows for a maximum height of 80 feet. For buildings in the "T" Bulk District, bulk controls apply beginning at 80 feet, and the maximum length dimension is 110 feet, while the maximum diagonal dimension is 125 feet. Per Section 253 of the Planning Code, buildings within the RC zoning districts that exceed a height of 50 feet are subject to Conditional Use Authorization.

The height of the Base Project exceeds the 50-foot height limit by 30 feet, thereby requiring Conditional Use Authorization before the Planning Commission. The specific findings related to the Conditional Use Authorization are analyzed in item 7 below.

Beginning at the height of the bulk controls (80 feet) for the Project Site, the proposed Project would have a maximum length dimension of 65 feet and a maximum diagonal dimension of 99 feet. Given that both dimensions are below the bulk limit thresholds, the Project is in compliance with Code Section 270.

Per California Government Code Sections 65915-65918, the Project Sponsor has elected to utilize the State Density Bonus Law and requests a waiver from the 80-foot height limit, which the project exceeds by 6 feet. This waiver in height limit is necessary to enable the construction of the project with the increased density provided by Government Code Section 65915(f)(2).

- I. **Transportation Demand Management (TDM) Plan.** Pursuant to Planning Code Section 169 and the TDM Program Standards, the Project shall finalize a TDM Plan prior Planning Department approval of the first Building Permit or Site Permit. As currently proposed, the Project must achieve a target of 10 points.

The Project submitted a completed Environmental Evaluation Application on May 15, 2020. Therefore, the Project must only achieve 100% of the point target established in the TDM Program Standards,

resulting in a required target of 10 points. As currently proposed, the Project will achieve a total of 14 points through the following TDM measures:

- Bicycle Parking (Option A)
- On-Site Affordable Housing (Option B)
- Parking Supply (Option K)

- J. **Shadows.** Planning Code Section 295 requires a shadow analysis for projects over 40 feet in height to ensure that new buildings would not cast new shadows on properties that are under the jurisdiction of the San Francisco Recreation and Park Department.

A shadow analysis was completed that examined the project as it is currently proposed. The analysis found that no net shadow would be added to any Recreation and Park Department Properties and thus the Project complies with Planning Code Section 295.

- K. **Transportation Sustainability Fee.** Planning Code Section 411A is applicable to new development that results in more than twenty dwelling units.

The Project includes approximately 36,860 gross square feet of new residential use. This square footage shall be subject to the Transportation Sustainability Fee, as outlined in Planning Code Section 411A.

- L. **Residential Child-Care Impact fee.** Planning Code Section 414A is applicable to new development that results in at least one net new residential unit.

The project includes approximately 36,860 gsf of new residential use associated with the new construction of 101 Group Housing units. This square footage shall be subject to the Residential Child-Care Impact Fee, as outlined in Planning Code Section 414A.

- M. **Inclusionary Affordable Housing Program.** Planning Code Section 415 sets forth the requirements and procedures for the Inclusionary Affordable Housing Program. Under Planning Code Sections 415.3 and 419.3, these requirements apply to projects that consist of 10 or more units. The applicable percentage is dependent on the number of units in the project, the zoning of the property, and the date of the accepted Project Application. A Project Application was accepted on November 4, 2019; therefore, pursuant to Planning Code Section 415.3, the Inclusionary Affordable Housing Program requirement for the On-Site Affordable Housing Alternative is to provide 25% of the proposed base density units as affordable.

Pursuant to Planning Code Section 415.5, the Project may pay the Affordable Housing Fee (“Fee”). This Fee is made payable to the Department of Building Inspection (“DBI”) for use by the Mayor’s Office of Housing and Community Development for the purpose of increasing affordable housing citywide. Alternatively, the Project can designate a certain number of dwelling units as part of the inclusionary affordable housing program. The applicable percentage is dependent on the number of units in the project, the zoning of the property, and the date that the project submitted a complete Environmental Evaluation Application. In addition, under the State Density Bonus Law, Government Code section 65915 et seq, a project is entitled to a density bonus, concessions and incentives, and waivers of development standards only if it provides on-site affordable units.

The Project Sponsor has demonstrated that the Project is eligible for the On-Site Affordable Housing Alternative under Planning Code Section 415.5 and 415.6, and has submitted an 'Affidavit of Compliance with the Inclusionary Affordable Housing Program: Planning Code Section 415,' to satisfy the requirements of the Inclusionary Affordable Housing Program by providing the affordable housing on-site instead of through payment of the Affordable Housing Fee. In order for the Project Sponsor to be eligible for the On-Site Affordable Housing Alternative, the Project Sponsor must submit an 'Affidavit of Compliance with the Inclusionary Affordable Housing Program: Planning Code Section 415,' to the Planning Department stating that any affordable units designated as on-site units shall be rental units and will remain as rental units for the life of the project. The Project Sponsor submitted such Affidavit on February 5, 2021. The applicable percentage is dependent on the total number of units in the base project, the zoning of the property, and the date that the project submitted a complete Environmental Evaluation Application. A complete Environmental Evaluation Application was submitted on November 4, 2019; therefore, pursuant to Planning Code Section 415.3 the Inclusionary Affordable Housing Program requirement for the on-site Affordable Housing Alternative is to provide 25% of the total proposed dwelling units in the Base Project as affordable within the North of Market Residential Special Use District for projects of 25 or more units. Seventeen (17) of the total 67 Base Density units provided will be affordable units and payment of the affordable housing fee on remaining square footage; the total number of net new units with the State Density Bonus is 101 Group Housing units. If the Project becomes ineligible to meet its Inclusionary Affordable Housing Program obligation through the On-site Affordable Housing Alternative, it must pay the Affordable Housing Fee with interest, if applicable.

The provisions of Planning Code Section 415 apply to the entirety of the Project, including the bonus square footage gained under the State Density Bonus. The inclusionary housing fee will apply to the square footage of the Project that is attributable to the bonus.

7. Conditional Use Findings. Planning Code Section 303 establishes criteria for the Planning Commission to consider when reviewing applications for Conditional Use authorization. On balance, the project complies with said criteria in that:

- A. The proposed new uses and building, at the size and intensity contemplated and at the proposed location, will provide a development that is necessary or desirable, and compatible with, the neighborhood or the community.

The Downtown/Civic Center neighborhood contains a mix of predominantly three- to seven-story high-density residential buildings with commercial or institutional uses at the street level. The proposed residential building will be compatible with the existing neighborhood mix of uses. The Project will demolish an existing, vacant, non-residential mixed-use building to construct a new residential building containing 101 Group Housing units with a total capacity of 202 beds. 17 of the proposed units will be affordable.

- B. The proposed project will not be detrimental to the health, safety, convenience or general welfare of persons residing or working in the vicinity. There are no features of the project that could be detrimental to the health, safety or convenience of those residing or working the area, in that:

- (1) Nature of proposed site, including its size and shape, and the proposed size, shape and arrangement of structures;

The Project's proposed massing is generally consistent with the character and design of the neighborhood, and will not impede any development of surrounding properties. The proposed design is contemporary yet compatible, referencing character-defining features of the surrounding Uptown Tenderloin Historic District and is compatible with the district's size, scale, composition, and details. The massing is compatible in terms of lot occupancy, solid-to-void ratio, and vertical articulation. The design features a composite stone-clad double-height base, glazed storefront system at the ground floor and mezzanine, acrylic coat stucco siding at the shaft, and a pronounced metal cornice. Windows will be recessed no less than 4" and designed to relate to the typical paired double-hung windows on surrounding historic properties. Ventilation caps will be powder-coated to reflect iron brick ties and a belt course is proposed below the top floor for additional depth, as is common in surrounding properties.

- (2) The accessibility and traffic patterns for persons and vehicles, the type and volume of such traffic, and the adequacy of proposed off-street parking and loading;

The Planning Code does not require parking or loading within the RC-4 zoning district, and none is proposed. The project includes 45 Class 1 bicycle parking spaces and is well-situated for easy access to numerous public transit modes including numerous MUNI lines (31-Balboa, 19-Polk, 7X - Noriega) and the Civic Center BART station. The proposed residential use will not generate significant amounts of vehicular trips from the immediate neighborhood or citywide.

- (3) The safeguards afforded to prevent noxious or offensive emissions such as noise, glare, dust and odor;

The Project will not introduce operational noises or odors that are detrimental, excessive, or atypical for the area and glazing and other reflective materials are not excessive to generate glare.

- (4) Treatment given, as appropriate, to such aspects as landscaping, screening, open spaces, parking and loading areas, service areas, lighting and signs;

The Project will add three new street trees where there are currently none and six Class 2 bicycle parking spaces in place of the existing four. No modifications are proposed to the existing adjacent loading zone or MUNI bus stop.

- C. That the use as proposed will comply with the applicable provisions of the Planning Code and will not adversely affect the General Plan.

The Project complies with all relevant requirements and standards of the Planning Code and is consistent with objectives and policies of the General Plan as detailed below.

- D. That the use as proposed would provide development that is in conformity with the purpose of

the applicable Neighborhood Commercial District.

The proposed project is consistent with the stated purposes of NC-1 Districts in that the intended use is located at the ground floor, will provide a compatible convenience service for the immediately surrounding neighborhoods during daytime hours.

8. Individually Requested State Density Bonus Required Findings. Before approving an application for a Density Bonus, Incentive, Concession, or waiver, for any Individually Requested Density Bonus Project, the Planning Commission shall make the following findings as applicable:

- A. The Housing Project is eligible for the Individually Requested Density Bonus Program.

The Project provides at least 15% of the proposed rental dwelling units (10 units) as affordable to very low-income households, defined as those earning 50% of area median income, and is therefore entitled to a 50% density bonus under California Government Code Sections 65915-95918, as revised under AB 2345.

- B. The Housing Project has demonstrated that any Concessions or Incentives reduce actual housing costs, as defined in Section 50052.5 of the California Health and Safety Code, or for rents for the targeted units, based upon the financial analysis and documentation provided.

The Project does not request any Concessions from the Planning Code.

- C. If a waiver or modification is requested, a finding that the Development Standards for which the waiver is requested would have the effect of physically precluding the construction of the Housing Project with the Density Bonus or Concessions and Incentives permitted.

The Project requests the following waivers from the Planning Code Development Standards: 1) Height (Planning Code Section 250); 2) Upper Story Setback (Planning Code Section 132.2); and 3) Rear Yard (Planning Code Section 134).

The Project provides a total residential floor area equal to the square footage afforded to a base project (one which complies with all development standards), plus the 50% floor area bonus afforded under the Individually State Density Bonus. The additional floor area is obtained by increasing the total height of the building by one floor, not providing an upper story setback, and by reducing the required rear yard by five feet to accommodate additional floor area for the Group Housing units.

- D. If the Density Bonus is based all or in part on donation of land, a finding that all the requirements included in Government Code Section 65915(g) have been met.

The Project does not include a donation of land, and this is not the basis for the Density Bonus.

- E. If the Density Bonus, Concession or Incentive is based all or in part on the inclusion of a Child Care Facility, a finding that all the requirements included in Government Code Section 65915(h) have been met.

The project does not include a Child Care Facility, and this is not the basis for the Density Bonus.

- F. If the Concession or Incentive includes mixed-use development, a finding that all the requirements included in Government Code Section 65915(k) have been met.

The project does not include mixed-use development, Concessions, or Incentives.

- 9. General Plan Compliance.** The Project is, on balance, consistent with the following Objectives and Policies of the General Plan:

HOUSING ELEMENT

Objectives and Policies

OBJECTIVE 1

IDENTIFY AND MAKE AVAILABLE FOR DEVELOPMENT ADEQUATE SITES TO MEET THE CITY'S HOUSING NEEDS, ESPECIALLY PERMANENTLY AFFORDABLE HOUSING.

Policy 1.1

Plan for the full range of housing needs in the City and County of San Francisco, especially affordable housing.

Policy 1.10

Support new housing projects, especially affordable housing, where households can easily rely on public transportation, walking and bicycling for the majority of daily trips.

OBJECTIVE 4

FOSTER A HOUSING STOCK THAT MEETS THE NEEDS OF ALL RESIDENTS ACROSS LIFECYCLES.

Policy 4.4

Encourage sufficient and suitable rental housing opportunities, emphasizing permanently affordable rental units wherever possible.

Policy 4.5

Ensure that new permanently affordable housing is located in all of the City's neighborhoods, and encourage integrated neighborhoods, with a diversity of unit types provided at a range of income levels.

OBJECTIVE 11

SUPPORT AND RESPECT THE DIVERSE AND DISTINCT CHARACTER OF SAN FRANCISCO'S NEIGHBORHOODS.

Policy 11.1

Promote the construction and rehabilitation of well-designed housing that emphasizes beauty, flexibility, and innovative design, and respects existing neighborhood character.

Policy 11.2

Ensure implementation of accepted design standards in project approvals.

Policy 11.3

Ensure growth is accommodated without substantially and adversely impacting existing residential neighborhood character.

Policy 11.4

Continue to utilize zoning districts which conform to a generalized residential land use and density plan and the General Plan.

Policy 11.6

Foster a sense of community through architectural design, using features that promote community interaction.

OBJECTIVE 12

BALANCE HOUSING GROWTH WITH ADEQUATE INFRASTRUCTURE THAT SERVES THE CITY'S GROWING POPULATION.

Policy 12.1

Encourage new housing that relies on transit use and environmentally sustainable patterns of movement.

Policy 12.2

Consider the proximity of quality of life elements such as open space, childcare, and neighborhood services, when developing new housing units.

Policy 12.3

Ensure new housing is sustainably supported by the City's public infrastructure systems.

URBAN DESIGN ELEMENT

Objectives and Policies

OBJECTIVE 1

EMPHASIS OF THE CHARACTERISTIC PATTERN WHICH GIVES TO THE CITY AND ITS NEIGHBORHOODS AN IMAGE, A SENSE OF PURPOSE, AND A MEANS OF ORIENTATION.

Policy 1.3

Recognize that buildings, when seen together, produce a total effect that characterizes the city and its districts.

Policy 1.7

Recognize the natural boundaries of districts, and promote connections between districts.

10. Planning Code Section 101.1(b) establishes eight priority-planning policies and requires review of permits for consistency with said policies. On balance, the project complies with said policies in that:

- A. That existing neighborhood-serving retail uses be preserved and enhanced and future opportunities for resident employment in and ownership of such businesses be enhanced.

The project site does not possess any neighborhood-serving retail uses. The Project provides 101 new Group Housing units, which will enhance the nearby retail uses by providing new residents, who may patron and/or own these businesses.

- B. That existing housing and neighborhood character be conserved and protected in order to preserve the cultural and economic diversity of our neighborhoods.

The project site does possess any existing housing. The Project would provide 101 new Group Housing units, thus resulting in an overall increase in the neighborhood housing stock. The Project is expressive in design and relates well to the scale and form of the surrounding neighborhood and Uptown Tenderloin Historic District. For these reasons, the Project would protect and preserve the cultural and economic diversity of the neighborhood.

- C. That the City's supply of affordable housing be preserved and enhanced,

The Project does not currently possess any existing affordable housing. The Project will comply with the City's Inclusionary Housing Program by providing 17 below-market rate dwelling units for rent. Therefore, the Project will increase the stock of affordable housing units in the City.

- D. That commuter traffic not impede MUNI transit service or overburden our streets or neighborhood parking.

The Project Site is served by nearby public transportation options. The Project is located along three Muni bus lines (31-Balboa, 19-Polk, 7X – Noriega), and is within walking distance of the BART Station at Civic Center. The Project also provides sufficient bicycle parking for residents.

- E. That a diverse economic base be maintained by protecting our industrial and service sectors from displacement due to commercial office development, and that future opportunities for resident employment and ownership in these sectors be enhanced.

The Project does not include commercial office development but would provide a high-density housing option for numerous residents within proximity to the City's commercial center.

- F. That the City achieve the greatest possible preparedness to protect against injury and loss of life in an earthquake.

The Project will be designed and constructed to conform to the structural and seismic safety requirements of the Building Code. This proposal will not impact the property's ability to withstand an earthquake.

- G. That landmarks and historic buildings be preserved.

The property is located within the Uptown Tenderloin Historic District; however, the existing building was identified as a non-contributor to the district due to its non-residential use and numerous façade alterations. The proposed design of the new Project reflects the character-defining features of the surrounding district in massing, materials and design, yet would not create a false sense of historicism due to its use of contemporary materials. The Project does not pose any impacts to surrounding historic properties.

- H. That our parks and open space and their access to sunlight and vistas be protected from development.

The Project would not affect any adjacent parks' access to sunlight or vistas.

- 11. First Source Hiring.** The Project is subject to the requirements of the First Source Hiring Program as they apply to permits for residential development (Administrative Code Section 83.11), and the Project Sponsor shall comply with the requirements of this Program as to all construction work and on-going employment required for the Project. Prior to the issuance of any building permit to construct or a First Addendum to the Site Permit, the Project Sponsor shall have a First Source Hiring Construction and Employment Program approved by the First Source Hiring Administrator, and evidenced in writing. In the event that both the Director of Planning and the First Source Hiring Administrator agree, the approval of the Employment Program may be delayed as needed.

The Project Sponsor submitted a First Source Hiring Affidavit and prior to issuance of a building permit will execute a First Source Hiring Memorandum of Understanding and a First Source Hiring Agreement with the City's First Source Hiring Administration.

- 12.** The Project is consistent with and would promote the general and specific purposes of the Code provided under Section 101.1(b) in that, as designed, the Project would contribute to the character and stability of the neighborhood and would constitute a beneficial development.
- 13.** The Commission hereby finds that approval of the Conditional Use Authorization would promote the health, safety and welfare of the City.

DECISION

That based upon the Record, the submissions by the Applicant, the staff of the Department and other interested parties, the oral testimony presented to this Commission at the public hearings, and all other written materials submitted by all parties, the Commission hereby **APPROVES Conditional Use Authorization Application No. 2019-020740CUA** subject to the following conditions attached hereto as “EXHIBIT A” in general conformance with plans on file, dated January 28, 2021. and stamped “EXHIBIT B”, which is incorporated herein by reference as though fully set forth.

APPEAL AND EFFECTIVE DATE OF MOTION: Any aggrieved person may appeal this Conditional Use Authorization to the Board of Supervisors within thirty (30) days after the date of this Motion. The effective date of this Motion shall be the date of this Motion if not appealed (after the 30-day period has expired) OR the date of the decision of the Board of Supervisors if appealed to the Board of Supervisors. For further information, please contact the Board of Supervisors at (415) 554-5184, City Hall, Room 244, 1 Dr. Carlton B. Goodlett Place, San Francisco, CA 94102.

Protest of Fee or Exaction: You may protest any fee or exaction subject to Government Code Section 66000 that is imposed as a condition of approval by following the procedures set forth in Government Code Section 66020. The protest must satisfy the requirements of Government Code Section 66020(a) and must be filed within 90 days of the date of the first approval or conditional approval of the development referencing the challenged fee or exaction. For purposes of Government Code Section 66020, the date of imposition of the fee shall be the date of the earliest discretionary approval by the City of the subject development.

If the City has not previously given Notice of an earlier discretionary approval of the project, the Planning Commission’s adoption of this Motion, Resolution, Discretionary Review Action or the Zoning Administrator’s Variance Decision Letter constitutes the approval or conditional approval of the development and the City hereby gives **NOTICE** that the 90-day protest period under Government Code Section 66020 has begun. If the City has already given Notice that the 90-day approval period has begun for the subject development, then this document does not re-commence the 90-day approval period.

I hereby certify that the Planning Commission ADOPTED the foregoing Motion on March 25, 2021.

Jonas P. Ionin
Commission Secretary

AYES:

NAYS:

ABSENT:

RECUSE:

ADOPTED: March 25, 2020

EXHIBIT A

Authorization

This authorization is for a conditional use to construct a building that exceeds 50 feet in height at the street frontage, located at 468 Turk Street pursuant to Planning Code Section(s) **209.3, 253, and 303** within the **RC-4 and North of Market Residential Special Use Districts** and an **80-T** Height and Bulk District; in general conformance with plans, dated **January 28, 2021**, and stamped “EXHIBIT B” included in the docket for Record No. **2019-020740CUA** and subject to conditions of approval reviewed and approved by the Commission on **March 25, 2021** under Motion No **XXXXXX**. This authorization and the conditions contained herein run with the property and not with a particular Project Sponsor, business, or operator.

Recordation of Conditions Of Approval

Prior to the issuance of the building permit or commencement of use for the Project the Zoning Administrator shall approve and order the recordation of a Notice in the Official Records of the Recorder of the City and County of San Francisco for the subject property. This Notice shall state that the project is subject to the conditions of approval contained herein and reviewed and approved by the Planning Commission on **March 25, 2021** under Motion No **XXXXXX**.

Printing of Conditions of Approval on Plans

The conditions of approval under the 'Exhibit A' of this Planning Commission Motion No. **XXXXXX** shall be reproduced on the Index Sheet of construction plans submitted with the site or building permit application for the Project. The Index Sheet of the construction plans shall reference to the Conditional Use authorization and any subsequent amendments or modifications.

Severability

The Project shall comply with all applicable City codes and requirements. If any clause, sentence, section or any part of these conditions of approval is for any reason held to be invalid, such invalidity shall not affect or impair other remaining clauses, sentences, or sections of these conditions. This decision conveys no right to construct, or to receive a building permit. “Project Sponsor” shall include any subsequent responsible party.

Changes and Modifications

Changes to the approved plans may be approved administratively by the Zoning Administrator. Significant changes and modifications of conditions shall require Planning Commission approval of a new Conditional Use authorization.

CONDITIONS OF APPROVAL, COMPLIANCE, MONITORING, AND REPORTING

Performance

- 1. Validity.** The authorization and right vested by virtue of this action is valid for three (3) years from the effective date of the Motion. The Department of Building Inspection shall have issued a Building Permit or Site Permit to construct the project and/or commence the approved use within this three-year period.

For information about compliance, contact Code Enforcement, Planning Department at 628.652.7463, www.sfplanning.org

- 2. Expiration and Renewal.** Should a Building or Site Permit be sought after the three (3) year period has lapsed, the project sponsor must seek a renewal of this Authorization by filing an application for an amendment to the original Authorization or a new application for Authorization. Should the project sponsor decline to so file, and decline to withdraw the permit application, the Commission shall conduct a public hearing in order to consider the revocation of the Authorization. Should the Commission not revoke the Authorization following the closure of the public hearing, the Commission shall determine the extension of time for the continued validity of the Authorization.

For information about compliance, contact Code Enforcement, Planning Department at 628.652.7463, www.sfplanning.org

- 3. Diligent Pursuit.** Once a site or Building Permit has been issued, construction must commence within the timeframe required by the Department of Building Inspection and be continued diligently to completion. Failure to do so shall be grounds for the Commission to consider revoking the approval if more than three (3) years have passed since this Authorization was approved.

For information about compliance, contact Code Enforcement, Planning Department at 628.652.7463, www.sfplanning.org

- 4. Extension.** All time limits in the preceding three paragraphs may be extended at the discretion of the Zoning Administrator where implementation of the project is delayed by a public agency, an appeal or a legal challenge and only by the length of time for which such public agency, appeal or challenge has caused delay.

For information about compliance, contact Code Enforcement, Planning Department at 628.652.7463, www.sfplanning.org

- 5. Conformity with Current Law.** No application for Building Permit, Site Permit, or other entitlement shall be approved unless it complies with all applicable provisions of City Codes in effect at the time of such approval.

For information about compliance, contact Code Enforcement, Planning Department at 628.652.7463,

www.sfplanning.org

- 6. Priority Processing.** This Project was enrolled into the Priority Processing Program, as a Type 3 Project, pursuant to Director's Bulletin No. 2.

For information about compliance, contact the Case Planner, Planning Department at 628.652.7463, www.sfplanning.org

- 7. Mitigation Measures.** Mitigation measures described in the MMRP attached as Exhibit C are necessary to avoid potential significant effects of the proposed project and have been agreed to by the project sponsor. Their implementation is a condition of project approval.

For information about compliance, contact Code Enforcement, Planning Department at 628.652.7463, www.sfplanning.org

Entertainment Commission – Noise Attenuation Conditions

- 8. Chapter 116 Residential Projects.** The Project Sponsor shall comply with the "Recommended Noise Attenuation Conditions for Chapter 116 Residential Projects," which were recommended by the Entertainment Commission on August 25, 2015. These conditions state:

- A. **Community Outreach.** Project Sponsor shall include in its community outreach process any businesses located within 300 feet of the proposed project that operate between the hours of 9PM-5AM. Notice shall be made in person, written or electronic form.
- B. **Sound Study.** Project sponsor shall conduct an acoustical sound study, which shall include sound readings taken when performances are taking place at the proximate Places of Entertainment, as well as when patrons arrive and leave these locations at closing time. Readings should be taken at locations that most accurately capture sound from the Place of Entertainment to best of their ability. Any recommendation(s) in the sound study regarding window glaze ratings and soundproofing materials including but not limited to walls, doors, roofing, etc. shall be given highest consideration by the project sponsor when designing and building the project.
- C. **Design Considerations.** Adopt and implement project window specifications, STC ratings, and recommended HVAC system per official Acoustical Study that will be conducted before the start of construction and share findings and implementation plans with the Entertainment Commission.
- D. **Disclosure Requirements.**
 - i. During design phase, project sponsor shall consider the entrance and egress location and paths of travel at the Place(s) of Entertainment in designing the location of (a) any entrance/egress for the residential building and (b) any parking garage in the building.
 - ii. In designing doors, windows, and other openings for the residential building, project sponsor should consider the POE's operations and noise during all hours of the day and night.

- iii. During the design phase, project sponsor shall consider an outdoor lighting plan at the development site to protect residents as well as patrons of surrounding Places of Entertainment.
- E. **Construction Impacts.** Project sponsor shall communicate with adjacent or nearby Place(s) of Entertainment as to the construction schedule, daytime and nighttime, and consider how this schedule and any storage of construction materials may impact the POE operations.
- F. **Communication.** Project Sponsor shall make a cell phone number available to Place(s) of Entertainment management during all phases of development through construction. In addition, a line of communication should be created to ongoing building management throughout the occupation phase and beyond.
- G. Adopt and implement project window specifications, STC ratings, and recommended HVAC system per official Acoustical Study that will be conducted before the start of construction and share findings and implementation plans with the Entertainment Commission.
- H. **Disclosure of Requirements.** In addition to including required language from Administrative Code Chapter 116.8 “Disclosure Requirements for Transfer of Real Property for Residential Use,” the disclosure shall also include the disclosure of potential noise exposure to low-frequency (bass) noise levels that will be noticeable inside some of the residences.

Design – Compliance at Plan Stage

9. **Final Materials.** The Project Sponsor shall continue to work with Planning Department on the building design. Final materials, glazing, color, texture, landscaping, and detailing shall be subject to Department staff review and approval. The architectural addenda shall be reviewed and approved by the Planning Department prior to issuance.

For information about compliance, contact the Case Planner, Planning Department at 628.652.7329, www.sfplanning.org

10. **Garbage, Composting and Recycling Storage.** Space for the collection and storage of garbage, composting, and recycling shall be provided within enclosed areas on the property and clearly labeled and illustrated on the building permit plans. Space for the collection and storage of recyclable and compostable materials that meets the size, location, accessibility and other standards specified by the San Francisco Recycling Program shall be provided at the ground level of the buildings.

For information about compliance, contact the Case Planner, Planning Department at 628.652.7329, www.sfplanning.org

11. **Rooftop Mechanical Equipment.** Pursuant to Planning Code 141, the Project Sponsor shall submit a roof plan to the Planning Department prior to Planning approval of the building permit application. Rooftop

mechanical equipment, if any is proposed as part of the Project, is required to be screened so as not to be visible from any point at or below the roof level of the subject building.

For information about compliance, contact the Case Planner, Planning Department at 415-558-6378, www.sfplanning.org

- 12. Transformer Vault Location.** The location of individual project PG&E Transformer Vault installations has significant effects to San Francisco streetscapes when improperly located. However, they may not have any impact if they are installed in preferred locations. Therefore, the Planning Department in consultation with Public Works shall require the following location(s) for transformer vault(s) for this project: sidewalk. This location has the following design considerations: streetscape and building frontage details. The above requirement shall adhere to the Memorandum of Understanding regarding Electrical Transformer Locations for Private Development Projects between Public Works and the Planning Department dated January 2, 2019.

For information about compliance, contact Bureau of Street Use and Mapping, Department of Public Works at 628.271.2000, www.sfpbpublicworks.org

Parking and Traffic

- 13. Transportation Demand Management (TDM) Program.** Pursuant to Planning Code Section 169, the Project shall finalize a TDM Plan prior to the issuance of the first Building Permit or Site Permit to construct the project and/or commence the approved uses. The Property Owner, and all successors, shall ensure ongoing compliance with the TDM Program for the life of the Project, which may include providing a TDM Coordinator, providing access to City staff for site inspections, submitting appropriate documentation, paying application fees associated with required monitoring and reporting, and other actions.

Prior to the issuance of the first Building Permit or Site Permit, the Zoning Administrator shall approve and order the recordation of a Notice in the Official Records of the Recorder of the City and County of San Francisco for the subject property to document compliance with the TDM Program. This Notice shall provide the finalized TDM Plan for the Project, including the relevant details associated with each TDM measure included in the Plan, as well as associated monitoring, reporting, and compliance requirements.

For information about compliance, contact the TDM Performance Manager at tdm@sfgov.org or 628.652.7340, www.sfplanning.org

- 21. Bicycle Parking.** The Project shall provide no fewer than 45 Class 1 bicycle parking spaces as required by Planning Code Sections 155.1 and 155.2.

For information about compliance, contact Code Enforcement, Planning Department at 628.652.7463, www.sfplanning.org

- 14. Managing Traffic During Construction.** The Project Sponsor and construction contractor(s) shall coordinate with the Traffic Engineering and Transit Divisions of the San Francisco Municipal Transportation Agency (SFMTA), the Police Department, the Fire Department, the Planning Department, and other construction contractor(s) for any concurrent nearby Projects to manage traffic congestion and pedestrian circulation

effects during construction of the Project.

For information about compliance, contact Code Enforcement, Planning Department at 628.652.7463, www.sfplanning.org

Provisions

15. Anti-Discriminatory Housing. The Project shall adhere to the requirements of the Anti-Discriminatory Housing policy, pursuant to Administrative Code Section 1.61.

For information about compliance, contact the Case Planner, Planning Department at 628.652.7329, www.sfplanning.org

16. First Source Hiring. The Project shall adhere to the requirements of the First Source Hiring Construction and End-Use Employment Program approved by the First Source Hiring Administrator, pursuant to Section 83.4(m) of the Administrative Code. The Project Sponsor shall comply with the requirements of this Program regarding construction work and on-going employment required for the Project.

For information about compliance, contact the First Source Hiring Manager at 415.581.2335, www.onestopSF.org

17. Transportation Sustainability Fee. The Project is subject to the Transportation Sustainability Fee (TSF), as applicable, pursuant to Planning Code Section 411A.

For information about compliance, contact the Case Planner, Planning Department at 628.652.7329, www.sfplanning.org

18. Residential Child Care Impact Fee. The Project is subject to the Residential Child Care Fee, as applicable, pursuant to Planning Code Section 414A.

For information about compliance, contact the Case Planner, Planning Department at 628.652.7329, www.sfplanning.org

19. State Density Bonus Regulatory Agreement. Recipients of development bonuses under this Section 206.6 shall enter into a Regulatory Agreement with the City, as follows.

- A. The terms of the agreement shall be acceptable in form and content to the Planning Director, the Director of MOHCD, and the City Attorney. The Planning Director shall have the authority to execute such agreements.
- B. Following execution of the agreement by all parties, the completed Regulatory Agreement, or memorandum thereof, shall be recorded and the conditions filed and recorded on the Housing Project.
- C. The approval and recordation of the Regulatory Agreement shall take place prior to the issuance of the First Construction Document. The Regulatory Agreement shall be binding to all future owners and successors in interest.

- D. The Regulatory Agreement shall be consistent with the guidelines of the City's Inclusionary Housing Program and shall include at a minimum the following:
- i. The total number of dwelling units approved for the Housing Project, including the number of restricted affordable units;
 - ii. A description of the household income group to be accommodated by the HOME-SF Units, and the standards for determining the corresponding Affordable Rent or Affordable Sales Price. If required by the Procedures Manual, the project sponsor must commit to completing a market survey of the area before marketing restricted affordable units;
 - iii. The location, dwelling unit sizes (in square feet), and number of bedrooms of the restricted affordable units;
 - iv. Term of use restrictions for the life of the project;
 - v. A schedule for completion and occupancy of restricted affordable units;
 - vi. A description of any Concession, Incentive, waiver, or modification, if any, being provided by the City;
 - vii. A description of remedies for breach of the agreement (the City may identify tenants or qualified purchasers as third-party beneficiaries under the agreement); and
 - viii. Other provisions to ensure implementation and compliance with Section 206.6.

For information about compliance, contact the Case Planner, Planning Department at 415-575-9087, www.sf-planning.org or the Mayor's Office of Housing and Community Development at (415) 701-5500, www.sfmohcd.org.

20. Number of Required Units. The Subject Property is located in the North of Market Residential Special Use District Pursuant to Planning Code Section 415.3, the Project is required to provide 25% of the proposed dwelling units as affordable to qualifying households. The Base Project contains 67 units; therefore, 17 affordable units are required. The Project Sponsor will fulfill this requirement by providing the 17 affordable units on-site. If the number of market-rate units change, the number of required affordable units shall be modified accordingly with written approval from Planning Department staff in consultation with the Mayor's Office of Housing and Community Development ("MOHCD").

For information about compliance, contact the Case Planner, Planning Department at (628) 652-7600, www.sfplanning.org or the Mayor's Office of Housing and Community Development at (415) 701-5500, www.sfmohcd.org.

21. Mixed Income Levels for Affordable Units. The Subject Property is located in the North of Market Residential Special Use District. Pursuant to Planning Code Section 415.3, the Project is required to provide 25% of the proposed dwelling units as affordable to qualifying households. At least 15% must be affordable to low-income households, at least 5% must be affordable to moderate income households, and at least 5% must be affordable to middle income households. Rental Units for low-income households shall have an affordable rent set at 55% of Area Median Income or less, with households earning up to 65% of Area Median Income eligible to apply for low-income units. Rental Units for moderate-income households shall have an affordable rent set at 80% of Area Median Income or less, with households earning from 65% to 90% of Area Median

Income eligible to apply for moderate-income units. Rental Units for middle-income households shall have an affordable rent set at 110% of Area Median Income or less, with households earning from 90% to 130% of Area Median Income eligible to apply for middle-income units. For any affordable units with rental rates set at 110% of Area Median Income, the units shall have a minimum occupancy of two persons. If the number of market-rate units change, the number of required affordable units shall be modified accordingly with written approval from Planning Department staff in consultation with the Mayor's Office of Housing and Community Development ("MOHCD").

For information about compliance, contact the Case Planner, Planning Department at (628) 652-7600, www.sfplanning.org or the Mayor's Office of Housing and Community Development at (415) 701-5500, www.sfmohcd.org.

- 22. Notice of Special Restrictions.** The affordable units shall be designated on a reduced set of plans recorded as a Notice of Special Restrictions on the property prior to the issuance of the first construction permit.

For information about compliance, contact the Case Planner, Planning Department at (628) 652-7600, www.sfplanning.org or the Mayor's Office of Housing and Community Development at (415) 701-5500, www.sfmohcd.org.

- 23. Duration.** Under Planning Code Section 415.8, all units constructed pursuant to Section 415.6, must remain affordable to qualifying households for the life of the project.

For information about compliance, contact the Case Planner, Planning Department at (628) 652-7600, www.sfplanning.org or the Mayor's Office of Housing and Community Development at (415) 701-5500, www.sfmohcd.org.

- 24. Reduction of On-Site Units after Project Approval.** Pursuant to Planning Code Section 415.5(g)(3), any changes by the project sponsor which result in the reduction of the number of on-site affordable units shall require public notice for hearing and approval from the Planning Commission.

For information about compliance, contact the Case Planner, Planning Department at (628) 652-7600, www.sfplanning.org or the Mayor's Office of Housing and Community Development at (415) 701-5500, www.sfmohcd.org.

- 25. Inclusionary Affordable Housing Conditions.** The Project is subject to the requirements of the Inclusionary Affordable Housing Program under Section 415 et seq. of the Planning Code and City and County of San Francisco Inclusionary Affordable Housing Program Monitoring and Procedures Manual ("Procedures Manual"). The Procedures Manual, as amended from time to time, is incorporated herein by reference, as published and adopted by the Planning Commission, and as required by Planning Code Section 415. Terms used in these conditions of approval and not otherwise defined shall have the meanings set forth in the Procedures Manual. A copy of the Procedures Manual can be obtained at the MOHCD at 1 South Van Ness Avenue or on the Planning Department or MOHCD websites, including on the internet at: <http://sf-planning.org/Modules/ShowDocument.aspx?documentid=4451>. As provided in the Inclusionary Affordable Housing Program, the applicable Procedures Manual is the manual in effect at the time the subject units are

made available for sale.

For information about compliance, contact the Case Planner, Planning Department at (628) 652-7600, www.sfplanning.org or the Mayor's Office of Housing and Community Development at (415) 701-5500, www.sfmohcd.org.

- a. The affordable unit(s) shall be designated on the building plans prior to the issuance of the first construction permit by the Department of Building Inspection ("DBI"). The affordable unit(s) shall (1) be constructed, completed, ready for occupancy and marketed no later than the market rate units, and (2) be evenly distributed throughout the building; and (3) be of comparable overall quality, construction and exterior appearance as the market rate units in the principal project. The interior features in affordable units should be generally the same as those of the market units in the principal project, but need not be the same make, model or type of such item as long they are of good and new quality and are consistent with then-current standards for new housing. Other specific standards for on-site units are outlined in the Procedures Manual.
- b. If the units in the building are offered for rent, the affordable unit(s) shall be rented to qualifying households, with a minimum of 15% of the units affordable to low-income households, 5% to moderate-income households, and the remaining 5% of the units affordable to middle-income households such as defined in the Planning Code and Procedures Manual. The initial and subsequent rent level of such units shall be calculated according to the Procedures Manual. Limitations on (i) occupancy; (ii) lease changes; (iii) subleasing, and; are set forth in the Inclusionary Affordable Housing Program and the Procedures Manual.
- c. The affordable units that satisfy both the Density Bonus Law and the Inclusionary Affordable Housing Program shall be rented to very low-income households, as defined as households earning 50% of AMI in the California Health and Safety Code Section 50105 and/or California Government Code Sections 65915-65918, the State Density Bonus Law. The income table used to determine the rent and income levels for the Density Bonus units shall be the table required by the State Density Bonus Law. If the resultant rent or income levels at 50% of AMI under the table required by the State Density Bonus Law are higher than the rent and income levels at 55% of AMI under the Inclusionary Affordable Housing Program, the rent and incomes levels shall default to the maximum allowable rent and income levels for affordable units under the Inclusionary Affordable Housing Program. After such Density Bonus Law units have been rented for a term of 55 years, the subsequent rent and income levels of such units may be adjusted to (55) percent of Area Median Income under the Inclusionary Affordable Housing Program, using income table called "Maximum Income by Household Size derived from the Unadjusted Area Median Income for HUD Metro Fair Market Rent Area that contains San Francisco," and shall remain affordable for the remainder of the life of the Project. The initial and subsequent rent level of such units shall be calculated according to the Procedures Manual. The remaining units being offered for rent shall be rented to qualifying households, as defined in the Procedures Manual, whose gross annual income, adjusted for household size, does not exceed an average fifty-five (55) percent of Area Median Income under the income table called "Maximum Income by Household Size derived from the Unadjusted Area Median Income for HUD Metro Fair Market Rent Area that contains San Francisco." The initial and subsequent rent level of such units shall be calculated according to the Procedures Manual. Limitations on (i) occupancy; (ii) lease changes; and (iii) subleasing are set forth in the Inclusionary Affordable Housing Program and the Procedures Manual.

- d. The Project Sponsor is responsible for following the marketing, reporting, and monitoring requirements and procedures as set forth in the Procedures Manual. MOHCD shall be responsible for overseeing and monitoring the marketing of affordable units. The Project Sponsor must contact MOHCD at least six months prior to the beginning of marketing for any unit in the building.
- e. Required parking spaces shall be made available to initial buyers or renters of affordable units according to the Procedures Manual.
- f. Prior to the issuance of the first construction permit by DBI for the Project, the Project Sponsor shall record a Notice of Special Restriction on the property that contains these conditions of approval and a reduced set of plans that identify the affordable units satisfying the requirements of this approval. The Project Sponsor shall promptly provide a copy of the recorded Notice of Special Restriction to the Department and to MOHCD or its successor.
- g. If the Project Sponsor fails to comply with the Inclusionary Affordable Housing Program requirement, the Director of DBI shall deny any and all site or building permits or certificates of occupancy for the development project until the Planning Department notifies the Director of compliance. A Project Sponsor's failure to comply with the requirements of Planning Code Section 415 et seq. shall constitute cause for the City to record a lien against the development project and to pursue any and all available remedies at law, including interest and penalties, if applicable.

Monitoring - After Entitlement

26. Enforcement. Violation of any of the Planning Department conditions of approval contained in this Motion or of any other provisions of Planning Code applicable to this Project shall be subject to the enforcement procedures and administrative penalties set forth under Planning Code Section 176 or Section 176.1. The Planning Department may also refer the violation complaints to other city departments and agencies for appropriate enforcement action under their jurisdiction.

For information about compliance, contact Code Enforcement, Planning Department at 628.652.7463, www.sfplanning.org

27. Revocation due to Violation of Conditions. Should implementation of this Project result in complaints from interested property owners, residents, or commercial lessees which are not resolved by the Project Sponsor and found to be in violation of the Planning Code and/or the specific conditions of approval for the Project as set forth in Exhibit A of this Motion, the Zoning Administrator shall refer such complaints to the Commission, after which it may hold a public hearing on the matter to consider revocation of this authorization.

For information about compliance, contact Code Enforcement, Planning Department at 628.652.7463, www.sfplanning.org

Operation

28. Sidewalk Maintenance. The Project Sponsor shall maintain the main entrance to the building and all sidewalks abutting the subject property in a clean and sanitary condition in compliance with the Department of Public Works Streets and Sidewalk Maintenance Standards.

For information about compliance, contact Bureau of Street Use and Mapping, Department of Public Works, 628.271.2000, www.sfpublicworks.org

29. Community Liaison. Prior to issuance of a building permit to construct the project and implement the approved use, the Project Sponsor shall appoint a community liaison officer to deal with the issues of concern to owners and occupants of nearby properties. The Project Sponsor shall provide the Zoning Administrator and all registered neighborhood groups for the area with written notice of the name, business address, and telephone number of the community liaison. Should the contact information change, the Zoning Administrator and registered neighborhood groups shall be made aware of such change. The community liaison shall report to the Zoning Administrator what issues, if any, are of concern to the community and what issues have not been resolved by the Project Sponsor.

For information about compliance, contact Code Enforcement, Planning Department at 628.652.7463, www.sfplanning.org

30. Lighting. All Project lighting shall be directed onto the Project site and immediately surrounding sidewalk area only, and designed and managed so as not to be a nuisance to adjacent residents. Nighttime lighting shall be the minimum necessary to ensure safety, but shall in no case be directed so as to constitute a nuisance to any surrounding property.

For information about compliance, contact Code Enforcement, Planning Department at 628.652.7463, www.sfplanning.org

PROJECT DESCRIPTION

OVERVIEW

The Site is composed of a single 4,667 sf parcel (Block 0336 Lot 006.) It is located in the RC-4 “High Density Residential-Commercial” Zoning District, 80-T Height/Bulk District, “North of Market Special Use District-Subarea 1” and “Uptown Tenderloin Historic District”. It contains an existing 2-story 8,730 sf commercial building with no residential units and of no historic value (Survey Rating: 6X.)

Turk Street LLC, the Project Sponsor, proposes to demolish the existing structure and redevelop the property per the State’s Density Bonus Law (California Government Code Sections 65915-65918) into a rental group housing project. The project will consist of (101) Units with a street-level Community Room containing shared living facilities.

The proposed project is the “Bonus Project”, which includes the density to which the Project Sponsor is entitled per California State Law.

This is an application pursuant to the Mayor’s Executive Directive 17-02, which mandates expedited approval and permitting of the Project. This is also an application of a development permit pursuant to the Permit and Streamlining Act (Section 65920 et seq. of the California Government Code) and Section 15101 of the CEQA Guidelines. State Law requires the City to determine whether the application is complete within 30 days from submittal. If no written determination is made within 30 days, the application is deemed complete by operation of the Law on the 30th day.

THE “BASE DENSITY”

Per Planning Director Bulletin 6 (July 2019), and the State Density Bonus Law (SDBL), the Base Density is (67) Group Housing Units (4,667 SF / 70 SF/Units = 66.67; round up to 67)

THE “BONUS PROJECT” (SEE P. 6)

The Bonus Project proposes (101) Group Housing Units.

Per the SDBL (AB-2345 effective 01/01/2021), 15% of the Base Density Units are provided at 50% AMI, then a Bonus Density of 50% is allowed. (67 Base Units x 1.5 = 100.5; round up to 101 per the SDBL)

The building is 9 stories over 1 basement level with a height of 86’-0”.

The average Unit size is 220 gsf. The building has a (Residential) Gross Floor Area (GFA) of 32,722 sf. (45) Class I and (6) Class II bicycle parking spaces are provided. There is no automobile parking.

THE ARCHITECTURE (SEE P. 17 & 18)

Per the “Urban Design Guidelines” the street façade has a clearly defined BASE, MIDDLE and TOP. The proposed materiality is drawn from the best examples within the surrounding Historic District and neighboring buildings.

The BASE has a double-height expression and is comprised of pilasters with rough composite stone pedestals, and smooth composite stone shafts. These pilasters are topped with a trabeated belt course in composite stone running the full width of the building.

The MIDDLE is proposed in a smooth acrylic-coat stucco finish and generously-sized, high-performance windows.

The TOP consists of a substantial metal lintel & cornice with a solid parapet/guardrail enclosing the roof deck set back around the perimeter. Overall, the design constitutes a contemporary interpretation of features shared by the older buildings along the surrounding block face.

PROPOSAL FOR CONCESSIONS, INCENTIVES, AND WAIVERS (SEE P. 7)

Under the State Density Bonus Law, the Project Sponsor is entitled to 2 Concessions/Incentives as well as an unlimited number of Waivers of any Development Standard that would physically preclude construction of the project at the density proposed. The following Waivers are required to achieve the density bonus:

1. HEIGHT LIMIT: Waive the building height limit per Sec. 250 (from 80’-0” to 86’-0”) because compliance with the height limit would preclude the development of a 50% increase in Unit density.

2. UPPER STORY SETBACK: Waive potential setback/height limitations above 50’-0” per Sec. 132.2 because compliance with these limitations would preclude the development of a 50% increase in Unit density.

3. REAR YARD: Waive rear yard requirements per Sec. 134 and Table 209.3 because providing a Code-compliant rear yard that is 25% the depth of the Lot would preclude the development of a 50% increase in Unit density.

468 TURK STREET

RENTAL GROUP HOUSING DEVELOPMENT

PROJECT ENTITLEMENT APPLICATION (CONDITIONAL USE) FOR AN INDIVIDUALLY-REQUESTED STATE DENSITY BONUS PROJECT

TABLE OF CONTENTS

1. TABLE OF CONTENTS & PROJECT DESCRIPTION
2. GREEN BUILDING CHECKLIST
3. SITE PHOTOS
4. VICINITY MAP
5. SURVEY
6. BONUS PROJECT TITLE PAGE
7. DENSITY BONUS WAIVER & CONCESSION DIAGRAMS
8. BONUS PROJECT DESCRIPTION & DATA
9. SITE PLAN
10. BONUS PROJECT PLAN DIAGRAMS
11. BONUS PROJECT PLAN DIAGRAMS
12. BONUS PROJECT ELEVATIONS
13. BONUS PROJECT ELEVATIONS
14. BONUS PROJECT SECTIONS
15. TYPICAL UNIT - OVERVIEW
16. TYPICAL UNIT - INTERIOR VIEWS
17. TURK STREET FACADE & MATERIAL PALETTE
18. STREET VIEW



GS1: San Francisco Green Building Site Permit Submittal Form

Form version: February 1, 2018 (For permit applications January 2017 - December 2019)

INSTRUCTIONS:
 1. Select one (1) column to identify requirements for the project. For addition and alteration projects, applicability of specific requirements may depend upon project scope.
 2. Provide the Project Information in the box at the right.
 3. A LEED or GreenPoint Rated Scorecard is not required with the site permit application, but using such tools as early as possible is recommended.
 4. To ensure legibility of DBI archives, submittal must be a minimum of 24" x 36".
 Attachment GS2, GS3, GS4, GS5 or GS6 will be due with the applicable addendum. A separate "FINAL COMPLIANCE VERIFICATION" form will be required prior to Certificate of Completion. For details, see Administrative Bulletin 53. For Municipal projects, additional Environment Code Chapter 7 requirements may apply; see GS6.

CHECK THE ONE COLUMN THAT BEST DESCRIBES YOUR PROJECT →

LEED/GPR	TITLE	SOURCE OF REQUIREMENT	DESCRIPTION OF REQUIREMENT	NEW CONSTRUCTION				ALTERATIONS + ADDITIONS				PROJECT INFO	
				LOW-RISE RESIDENTIAL R 1-3 Floors	HIGH-RISE RESIDENTIAL R 4+ Floors	LARGE NON-RESIDENTIAL A,B,E,I,M 25,000 sq.ft. or greater	OTHER NON-RESIDENTIAL F,H,L,S,U or A,B,E,I,M less than 25,000 sq.ft.	RESIDENTIAL MAJOR ALTERATIONS + ADDITIONS R 25,000 sq.ft. or greater	OTHER RESIDENTIAL ALTERATIONS + ADDITIONS R adds any amount of conditioned area	NON-RESIDENTIAL MAJOR ALTERATIONS + ADDITIONS B,M 25,000 sq.ft. or greater	FIRST-TIME NON-RESIDENTIAL INTERIORS A,B,I,M 25,000 sq.ft. or greater		OTHER NON-RESIDENTIAL INTERIORS, ALTERATIONS + ADDITIONS A,B,E,F,H,L,I,M,S,U more than 1,000 sq.ft. or \$200,000
	Required LEED or GPR Certification Level	SFGB 4.103.1.1, 4.103.2.1.4, 103.3.1, 5.103.1.1, 5.103.3.1 & 5.103.4.1	Project is required to achieve sustainability certification listed at right.	LEED SILVER (50+) CERTIFIED	LEED SILVER (50+) or GPR (75+) CERTIFIED	LEED GOLD (60+) CERTIFIED	n/r	LEED GOLD (60+) or GPR (75+) CERTIFIED	n/r	LEED GOLD (60+) CERTIFIED	LEED GOLD (60+) CERTIFIED	n/r	468 TURK ST. PROJECT NAME
	LEED/GPR Point Adjustment for Retention/Demolition of Historic Features/Building	SFGB 4.104, 4.105, 5.104 & 5.105	Enter any applicable point adjustments in box at right.				n/r		n/r			n/r	0336-006 BLOCK/LOT
	LOW-EMITTING MATERIALS	CALGreen 4.504.2.1-5 & 5.504.4.1-6, SFGB 4.103.3.2, 5.103.1.9, 5.103.3.2 & 5.103.4.2	Use products that comply with the emission limit requirements of 4.504.2.1-5, 5.504.4.1-6 for adhesives, sealants, paints, coatings, carpet systems including cushions and adhesives, resilient flooring (80% of area), and composite wood products. Major alterations to existing residential buildings must use low-emitting coatings, adhesives and sealants, and carpet systems that meet the requirements for GPR measures K2, K3 and L2 or LEED EQc2, as applicable. New large non-residential interiors and major alterations to existing residential and non-residential buildings must also use interior paints, coatings, sealants, and adhesives when applied on-site, flooring and composite wood that meet the requirements of LEED credit Low-Emitting Materials (EQc2).	4.504.2.1-5	4.504.2.1-5	LEED EQc2	5.504.4.1-6	LEED EQc2 or GPR K2, K3 & L2	4.504.2.1-5	LEED EQc2	LEED EQc2	5.504.4.1-6	468 TURK ST. ADDRESS
WATER	INDOOR WATER USE REDUCTION	CALGreen 4.303.1 & 5.303.3, SFGB 5.103.1.2, SF Housing Code sec.12A10, SF Building Code ch.13A	Meet flush/flow requirements for: toilets (1.28gpf); urinals (0.125gpf wall, 0.5gpf floor); showerheads (2.0gpm); lavatories (1.2gpm private, 0.5gpm public/common); kitchen faucets (1.8gpm); wash fountains (1.8gpm); metering faucets (0.2gpc); food waste disposers (1gpm/8gpm). Residential projects must upgrade all non-compliant fixtures per SF Building Code ch.13A. New large non-residential buildings must also achieve minimum 30% indoor potable water use reduction as calculated to meet LEED credit Indoor Water Use Reduction (WEC2).			LEED WEC2 (2 pts)							R-2 PRIMARY OCCUPANCY
	NON-POTABLE WATER REUSE	Health Code art.12C	New buildings ≥ 40,000 sq.ft. must calculate a water budget. New buildings ≥250,000 sq.ft. must treat and use available rainwater, graywater, and foundation drainage and use in toilet and urinal flushing and irrigation. See www.sfwater.org for details.	n/r			n/r	n/r	n/r	n/r	n/r	n/r	36,838 GSF GROSS BUILDING AREA
	WATER-EFFICIENT IRRIGATION	Administrative Code ch.63	New construction projects with aggregated landscape area ≥500 sq.ft., or existing projects with modified landscape area ≥1,000 sq.ft. shall use low water use plants or climate appropriate plants, restrict turf areas and comply with Model Water Efficient Landscape Ordinance restrictions by calculated ETAF (.55 for residential, .45 for non-residential or less) or by prescriptive compliance for projects with ≥2,500 sq.ft. of landscape area. See www.sfwater.org for details.										01/28/2020 DESIGN PROFESSIONAL or PERMIT APPLICANT (sign & date)
	WATER METERING	CALGreen 5.303.1	Provide submeters for spaces projected to consume >1,000gal/day (or >100gal/day in buildings >50,000 sq.ft.).	n/r	n/r			n/r	n/r				
ENERGY	ENERGY EFFICIENCY	CA Energy Code	Comply with all provisions of the CA Title 24 Part 6 Energy Standards.										
	BETTER ROOFS	SFGB 4.201.1 & 5.201.1.2	New non-residential buildings >2,000 sq.ft. and ≤10 occupied floors, and new residential buildings of any size and ≤10 occupied floors, must designate 15% of roof Solar Ready, per Title 24 rules. Install photovoltaics or solar hot water systems in this area. With Planning Department approval, projects subject to SFPUC Stormwater Requirements may substitute living roof for solar energy systems.		≤10 floors			n/r	n/r	n/r	n/r	n/r	
	RENEWABLE ENERGY	SFGB 5.201.1.3	Non-residential buildings with ≥11 floors must acquire at least 1% of energy from on-site renewable sources, purchase green energy credits, or achieve 5 points under LEED credit Optimize Energy Performance (EAc2).	n/r	n/r			n/r	n/r	n/r	n/r	n/r	
	COMMISSIONING (Cx)	CALGreen 5.410.2 - 5.410.4.5.1	For projects ≥10,000 sq.ft. include OPR, BOD, and commissioning plan in design & construction. Commission to comply. Alterations & additions with new HVAC equipment must test and adjust all equipment.	n/r	n/r	LEED EAc1 opt. 1		n/r	n/r				
PARKING	BICYCLE PARKING	CALGreen 5.106.4, Planning Code 155.1-2	Provide short- and long-term bike parking equal to 5% of motorized vehicle parking, or meet SF Planning Code sec.155.1-2, whichever is greater.	SF Planning Code sec.155.1-2	SF Planning Code sec.155.1-2			if applicable SF Planning Code sec.155.1-2	if applicable SF Planning Code sec.155.1-2				if >10 stalls added
	DESIGNATED PARKING	CALGreen 5.106.5.2	Mark 8% of total parking stalls for low-emitting, fuel efficient, and carpool/van pool vehicles.					n/r	n/r				if >10 stalls added
	WIRING FOR EV CHARGERS	SFGB 4.106.4 & 5.106.5.3	Permit application January 2018 or after: Construct all new off-street parking spaces for passenger vehicles and trucks with dimensions capable of installing EVSE. Install service capacity and panelboards sufficient to provide ≥40A 208 or 240V to EV chargers at 20% of spaces. Install ≥40A 208 or 240V branch circuits to ≥10% of spaces, terminating close to the proposed EV charger location. Installation of chargers is not required. Projects with zero off-street parking exempt. See SFGB 4.106.4 or SFGB 5.106.5.3 for details. Permit applications prior to January 2018 only: Install infrastructure to provide electricity for EV chargers at 6% of spaces for non-residential (CALGreen 5.106.5.3), 3% of spaces for multifamily with ≥17 units (CALGreen 4.106.4.2), and each space in 1-2 unit dwellings (CALGreen 4.106.4.1). Installation of chargers is not required.					applicable for permit application January 2018 or after	n/r	applicable for permit application January 2018 or after	n/r	n/r	
WASTE DIVERSION	RECYCLING BY OCCUPANTS	SF Building Code AB-088	Provide adequate space and equal access for storage, collection and loading of compostable, recyclable and landfill materials.										
	CONSTRUCTION & DEMOLITION (C&D) WASTE MANAGEMENT	SFGB 4.103.2.3 & 5.103.1.3.1, Environment Code ch.14, SF Building Code ch.13B	For 100% of mixed C&D debris use registered transporters and registered processing facilities with a minimum of 65% diversion rate. Divert a minimum of 75% of total C&D debris if noted.		75% diversion	75% diversion					75% diversion		
HVAC	HVAC INSTALLER QUALS	CALGreen 4.702.1	Installers must be trained and certified in best practices.			n/r	n/r			n/r	n/r	n/r	
	HVAC DESIGN	CALGreen 4.507.2	HVAC shall be designed to ACCA Manual J, D, and S.			n/r	n/r			n/r	n/r	n/r	
	REFRIGERANT MANAGEMENT	CALGreen 5.508.1	Use no halons or CFCs in HVAC.					n/r	n/r				
GOOD NEIGHBOR	LIGHT POLLUTION REDUCTION	CA Energy Code CALGreen 5.106.8	Comply with CA Energy Code for Lighting Zones 1-4. Comply with 5.106.8 for Backlight/Uplight/Glare.	n/r	n/r			n/r	n/r				
	BIRD-SAFE BUILDINGS	Planning Code sec.139	Glass facades and bird hazards facing and/or near Urban Bird Refuges may need to treat their glass for opacity.										
	TOBACCO SMOKE CONTROL	CALGreen 5.504.7, Health Code art.19F	For non-residential projects, prohibit smoking within 25 feet of building entries, air intakes, and operable windows. For residential projects, prohibit smoking within 10 feet of building entries, air intakes, and operable windows and enclosed common areas.										
POLLUTION PREVENTION	STORMWATER CONTROL PLAN	Public Works Code art.4.2 sec.147	Projects disturbing ≥5,000 sq.ft. in combined or separate sewer areas, or replacing ≥2,500 impervious sq.ft. in separate sewer area, must implement a Stormwater Control Plan meeting SFPUC Stormwater Management Requirements. See www.sfwater.org for details.					if project extends outside envelope	if project extends outside envelope	if project extends outside envelope	if project extends outside envelope	if project extends outside envelope	if project extends outside envelope
	CONSTRUCTION SITE RUNOFF CONTROLS	Public Works Code art.4.2 sec.146	Provide a construction site Stormwater Pollution Prevention Plan and implement SFPUC Best Management Practices. See www.sfwater.org for details.	if disturbing ≥5,000 sq.ft.		if disturbing ≥5,000 sq.ft.	if disturbing ≥5,000 sq.ft.	if project extends outside envelope	if project extends outside envelope	if project extends outside envelope	if project extends outside envelope	if project extends outside envelope	if project extends outside envelope
INDOOR ENVIRONMENTAL QUALITY	ACOUSTICAL CONTROL	CALGreen 5.507.4.1-3, SF Building Code sec.1207	Non-residential projects must comply with sound transmission limits (STC-50 exteriors near freeways/airports; STC-45 exteriors if 65db Leq at any time; STC-40 interior walls/floor-ceilings between tenants). New residential projects' interior noise due to exterior sources shall not exceed 45dB.					n/r	n/r				
	AIR FILTRATION (CONSTRUCTION)	CALGreen 4.504.1-3 & 5.504.1-3	Seal permanent HVAC ducts/equipment stored onsite before installation.										
	AIR FILTRATION (OPERATIONS)	CALGreen 5.504.5.3, SF Health Code art.38	Non-residential projects must provide MERV-8 filters on HVAC for regularly occupied, actively ventilated spaces. Residential new construction and major alteration & addition projects in Air Pollutant Exposure Zones per SF Health Code art.38 must provide MERV-13 filters on HVAC.	if applicable	if applicable			if applicable	n/r				
	CONSTRUCTION IAQ MANAGEMENT PLAN	SFGB 5.103.1.8	During construction, meet SMACNA IAQ guidelines; provide MERV-8 filters on all HVAC.	n/r	n/r	LEED EQc3	n/r	n/r	n/r	n/r	n/r	n/r	n/r
RESIDENTIAL	GRADING & PAVING	CALGreen 4.106.3	Show how surface drainage (grading, swales, drains, retention areas) will keep surface water from entering the building.			n/r	n/r	if applicable	if applicable	n/r	n/r	n/r	n/r
	RODENT PROOFING	CALGreen 4.406.1	Seal around pipe, cable, conduit, and other openings in exterior walls with cement mortar or DBI-approved similar method.			n/r	n/r			n/r	n/r	n/r	n/r
	FIREPLACES & WOODSTOVES	CALGreen 4.503.1	Install only direct-vent or sealed-combustion, EPA Phase II-compliant appliances.			n/r	n/r			n/r	n/r	n/r	n/r
	CAPILLARY BREAK, SLAB ON GRADE	CALGreen 4.505.2	Slab on grade foundation requiring vapor retarder also requires a capillary break such as: 4 inches of base 1/2-inch aggregate under retarder, slab design specified by licensed professional.			n/r	n/r			n/r	n/r	n/r	n/r
	MOISTURE CONTENT	CALGreen 4.505.3	Wall and floor wood framing must have <19% moisture content before enclosure.			n/r	n/r			n/r	n/r	n/r	n/r
	BATHROOM EXHAUST	CALGreen 4.506.1	Must be ENERGY STAR compliant, ducted to building exterior, and its humidistat shall be capable of adjusting between <50% to >80% (humidistat may be separate component).			n/r	n/r			n/r	n/r	n/r	n/r



GREEN BUILDING CHECKLIST

01/28/2021

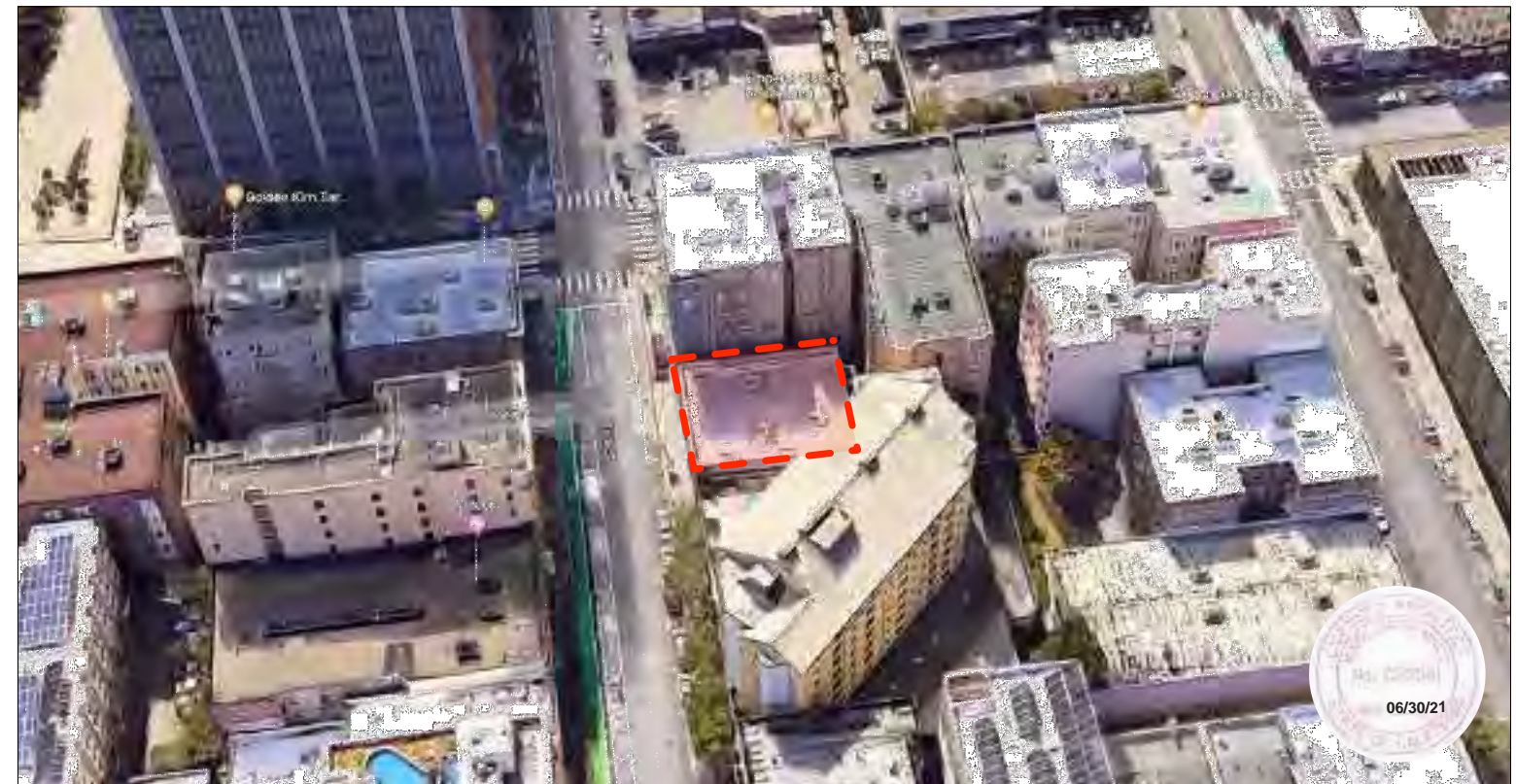
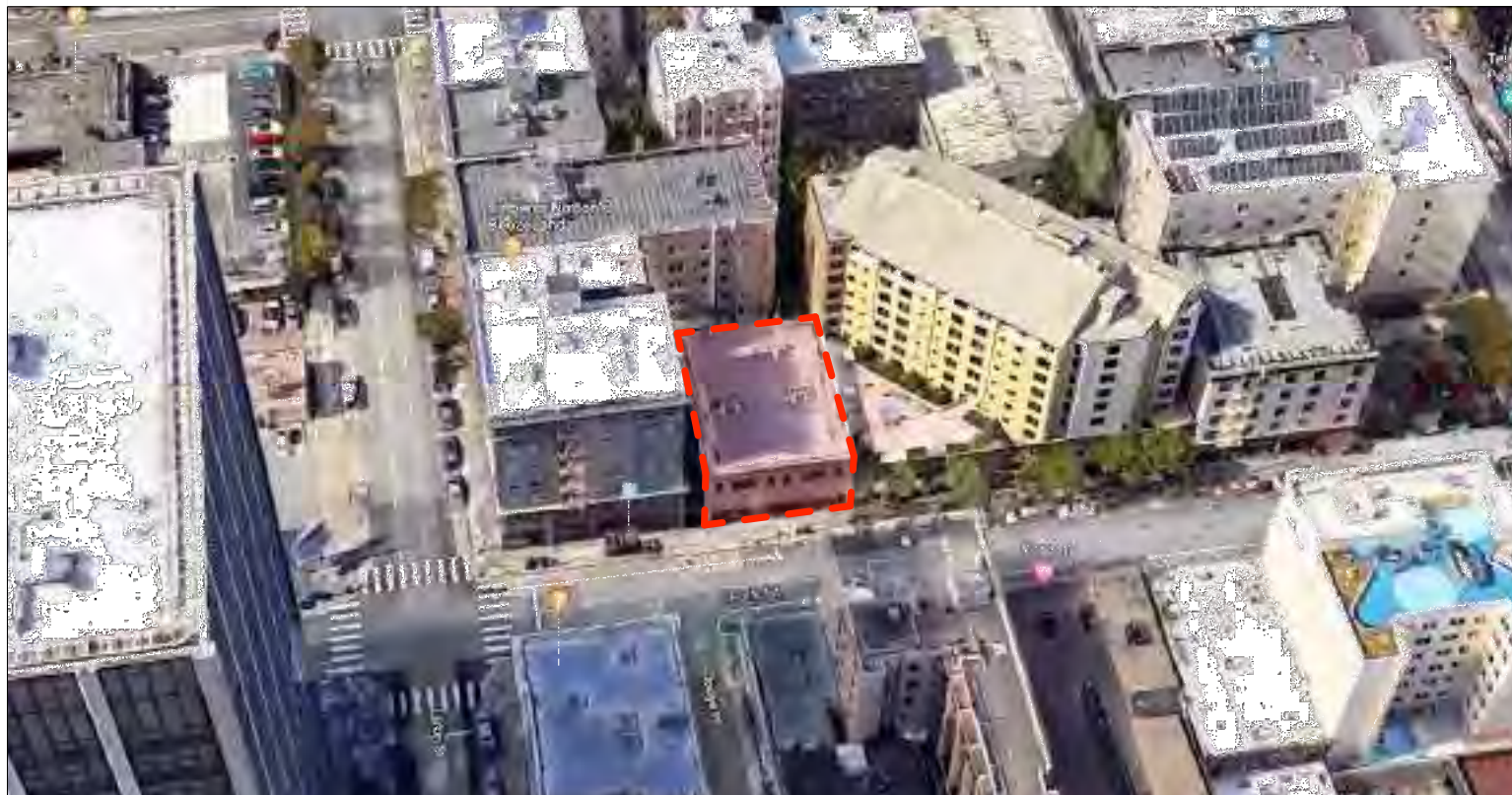
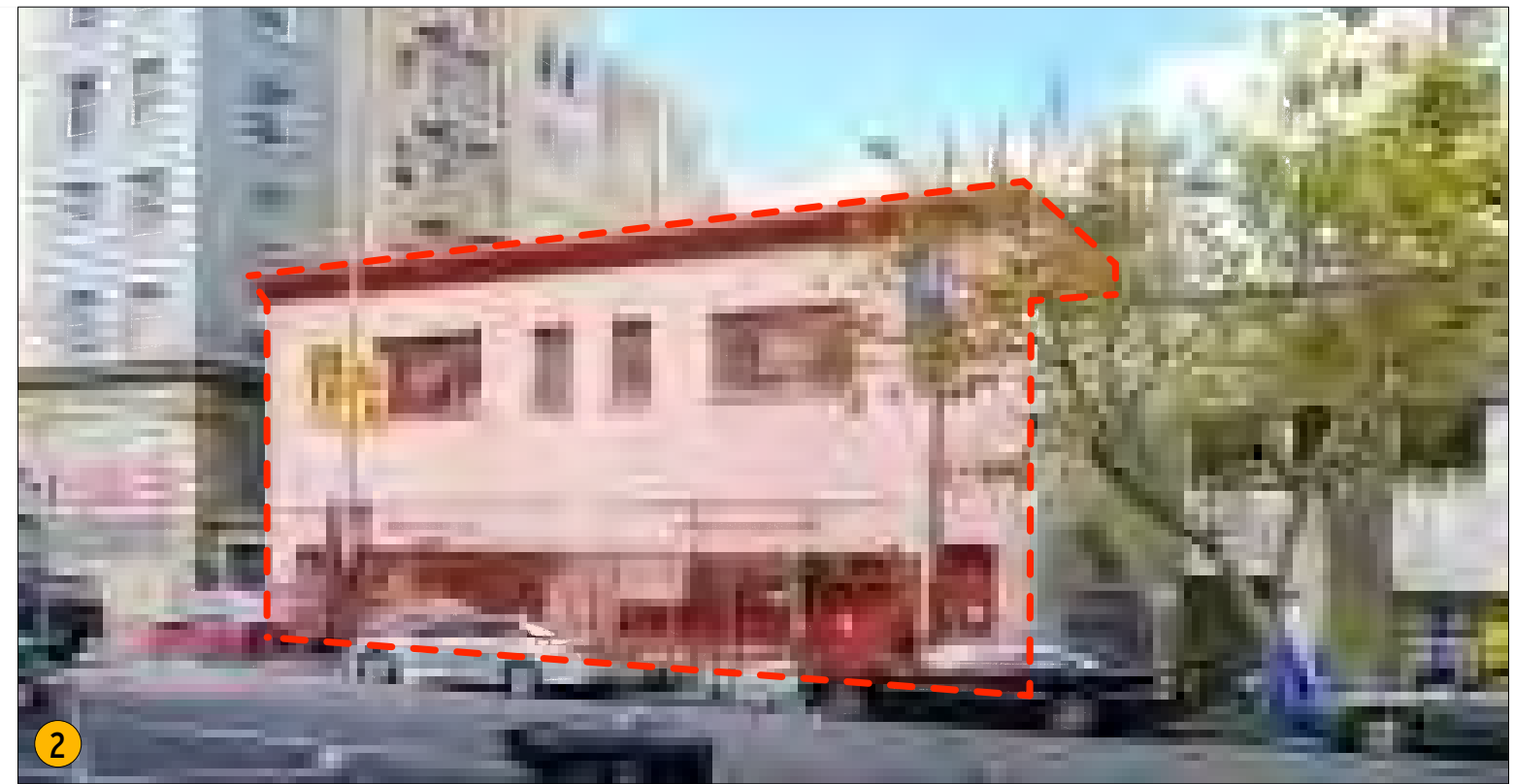
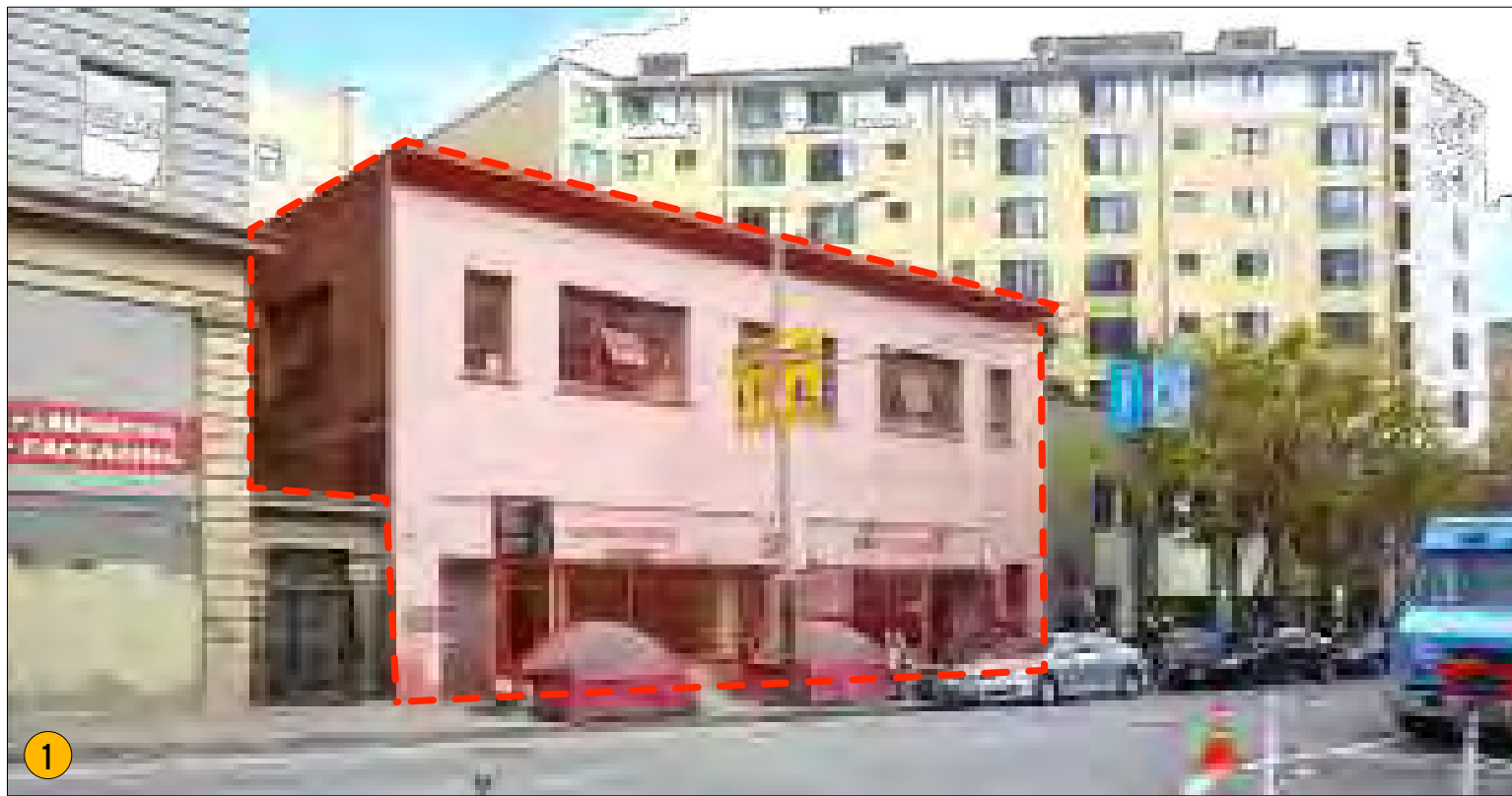

SITE PHOTOS 01/28/2021

**M A C Y
A R C H
I T E C
T U R E**

315 Linden Street San Francisco CA 94102 Tel 415 551 7630 www.macyarchitecture.com © 2021 Macy Architecture

All Rights Reserved.
The ideas represented
are the proprietary
intellectual property
of Macy Architecture.

PROJECT ENTITLEMENT APPLICATION (CU)

468 TURK STREET, SAN FRANCISCO, CA 94102
(BLOCK 0366 LOT 006)

PAGE 3 OF 18

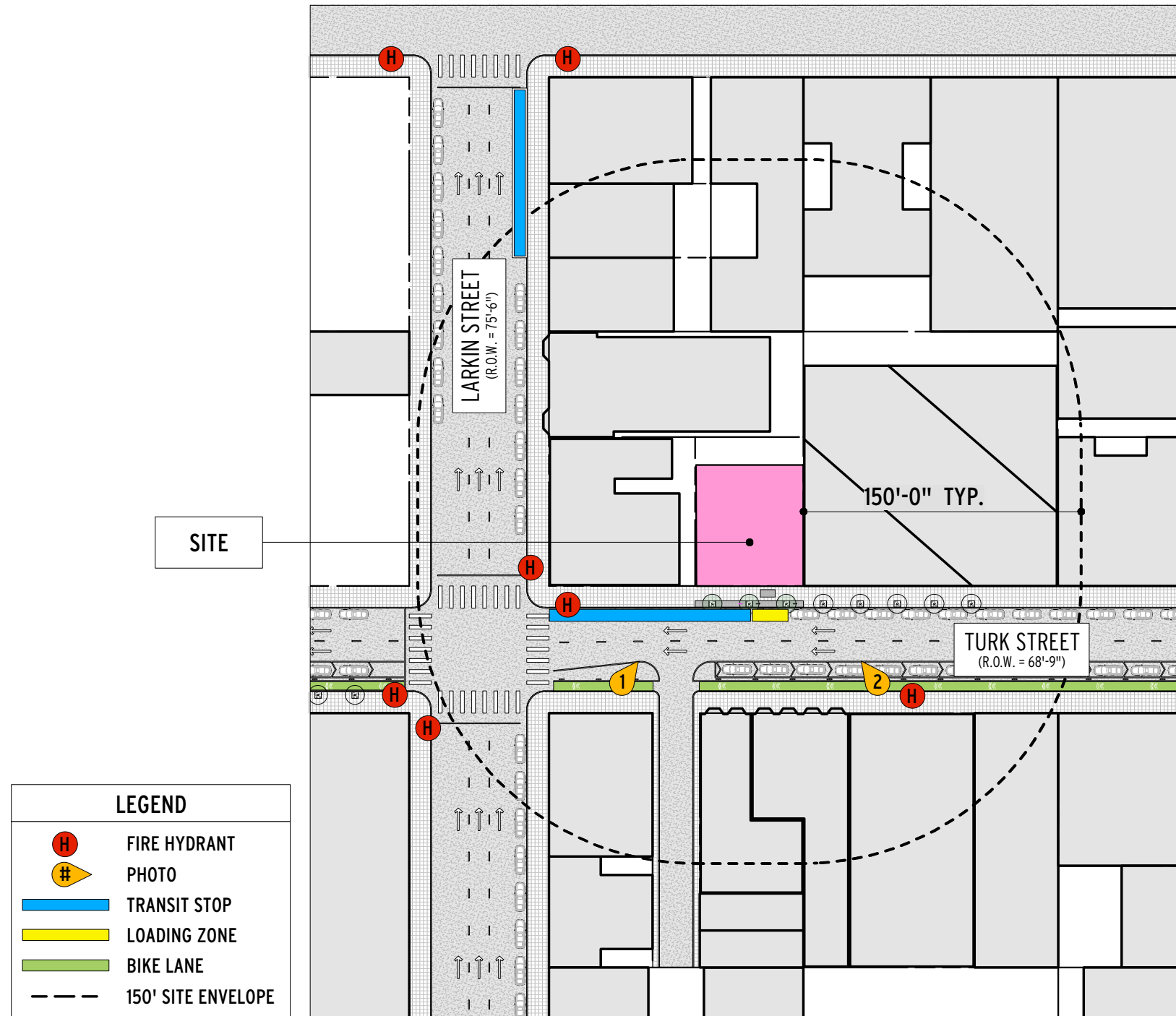

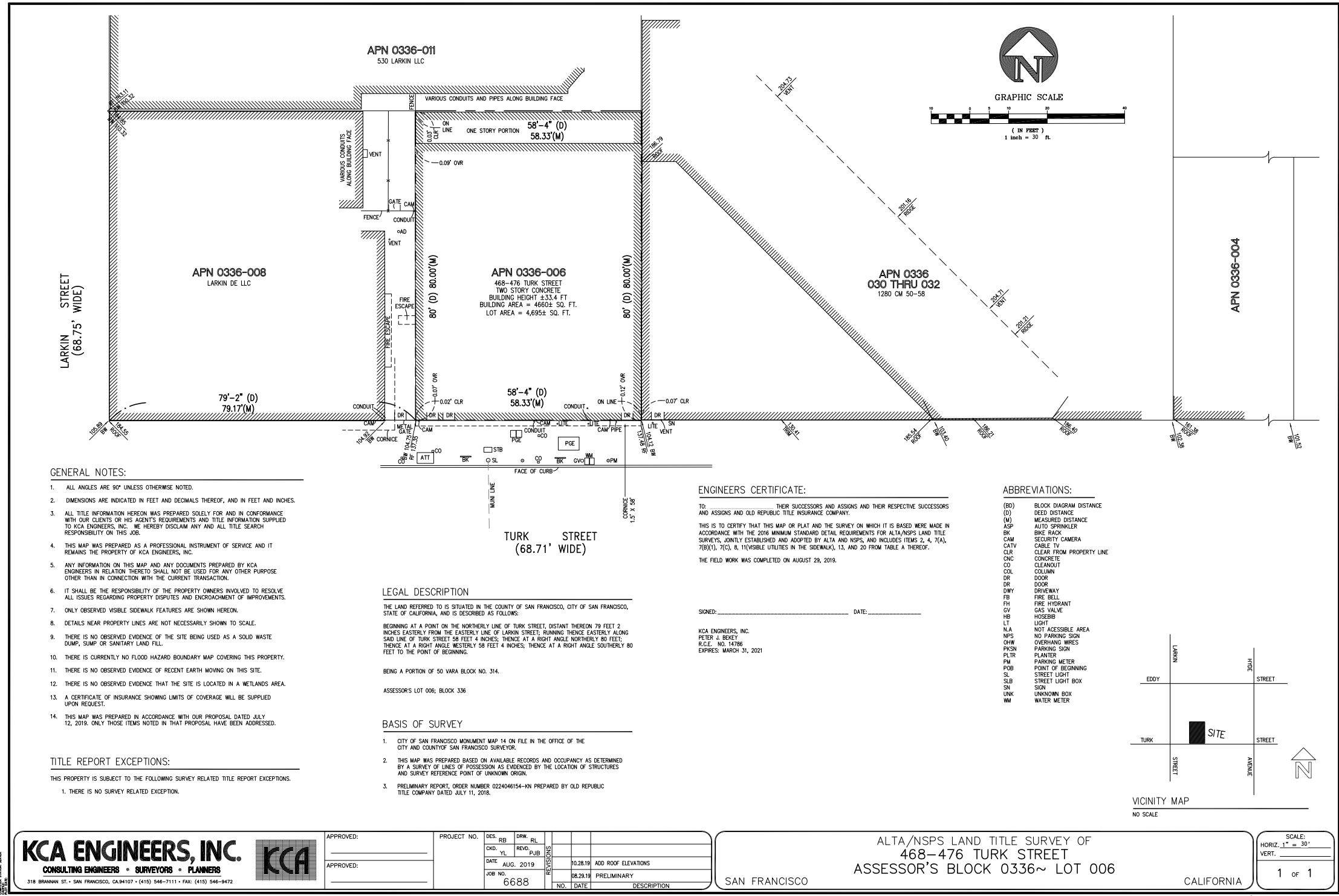

0' 30' 60' 90'

PROJECT NORTH
 1" = 30'-0"
 W E
 S

SURVEY 11/13/2020

**M A C Y
 A R C H
 I T E C
 T U R E**

315 Linden Street San Francisco CA 94102 Tel 415 551 7630 www.macyarchitecture.com © 2021 Macy Architecture

All Rights Reserved.
 The ideas represented
 are the proprietary
 intellectual property of
 Macy Architecture.

PROJECT ENTITLEMENT APPLICATION (CU)

468 TURK STREET, SAN FRANCISCO, CA 94102
 (BLOCK 0366 LOT 006)

PAGE 5 OF 18

PROPOSED BONUS PROJECT



01/28/2021

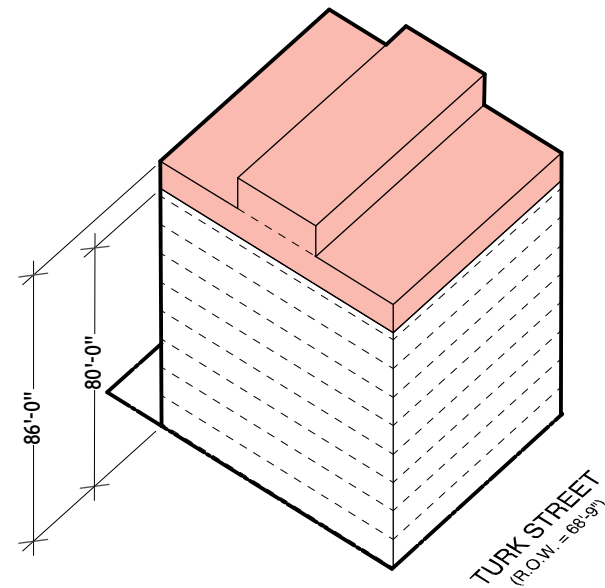

WAIVER 1

WAIVE BUILDING HEIGHT REQUIREMENTS PER S.F.P.C. SEC. 250

BUILDING HEIGHT REQUIREMENT WOULD PHYSICALLY PRECLUDE BONUS UNITS

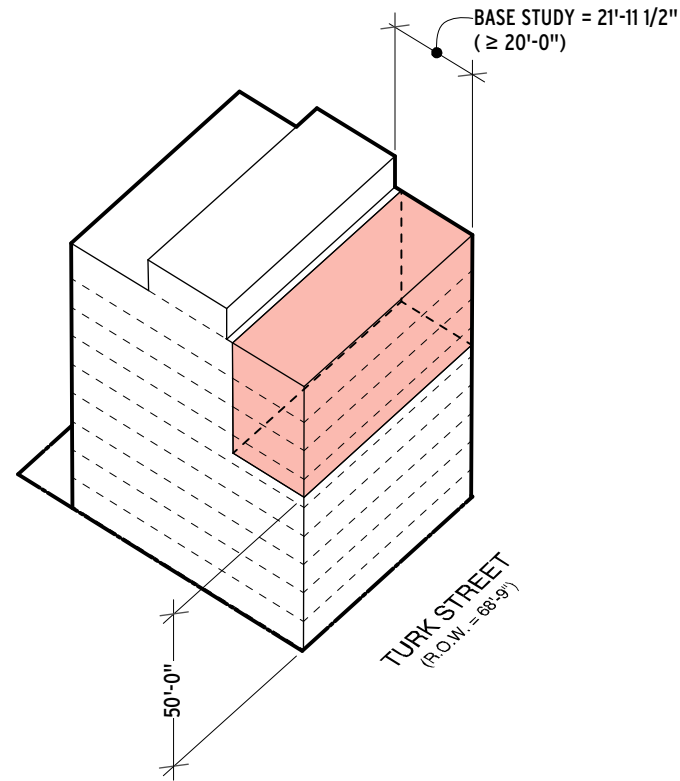

WAIVER 2

WAIVE UPPER STORY SETBACK PER S.F.P.C. SEC. 132.2

SETBACK REQUIREMENT WOULD PHYSICALLY PRECLUDE BONUS UNITS

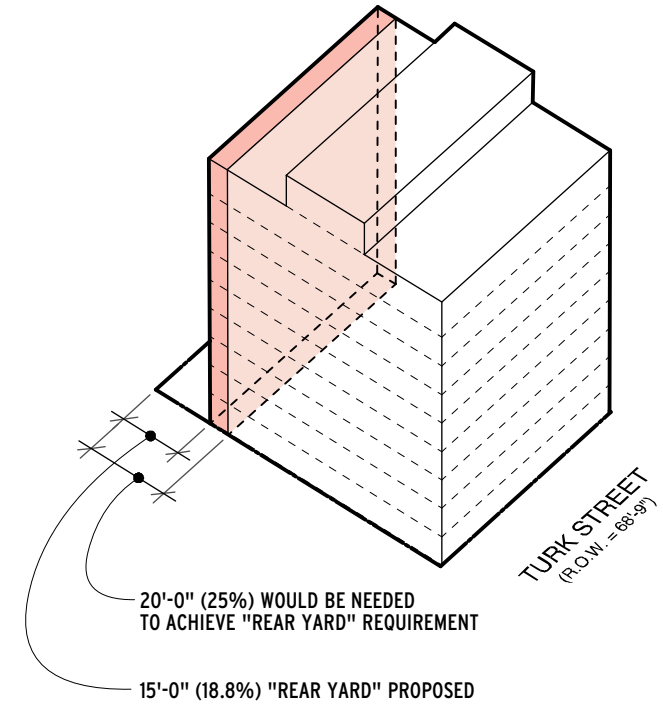

WAIVER 3

WAIVE REAR YARD REQUIREMENT PER S.F.P.C. SEC. 134 & TABLE 209.3

NOTE: THE PROJECT IS STILL PROVIDING A 15'-0" (18.8%) REAR YARD SETBACK.

REAR YARD REQUIREMENT WOULD PHYSICALLY PRECLUDE BONUS UNITS



AREA SUMMARY														
LEVEL	B	1	2	3	4	5	6	7	8	9	R	GSF	GSF%	GFA*
RESIDENTIAL	1,089	1,319	1,319	2,637	2,637	2,637	2,637	2,637	2,637	2,637	0	22,186	60%	22,186
RESIDENTIAL SHARED LIVING SPACES	431	854	785	161	161	161	161	161	161	161	0	3,197	9%	3,197
BICYCLE PARKING	386	0	0	0	0	0	0	0	0	0	0	386	1%	0
UTILITY	823	352	95	63	63	63	63	63	63	63	228	1,939	5%	888
CIRCULATION	842	1,126	789	866	866	866	866	866	866	866	333	9,152	25%	8,819
TOTAL	3,571	3,651	2,988	3,727	3,727	3,727	3,727	3,727	3,727	3,727	561	36,860	100%	35,090

* GFA per San Francisco Planning Code Sec. 102

UNIT SUMMARY														
LEVEL	B	1	2	3	4	5	6	7	8	9	R	GSF	QTY%	GFA*
UNIT TYPE	AVG. SF													
BD	220	QTY	5	6	6	12	12	12	12	12	12	12	0	101
		SF	1,089	1,319	1,319	2,637	2,637	2,637	2,637	2,637	2,637	2,637	0	22,186
TOTAL	220	QTY	5	6	6	12	12	12	12	12	12	12	0	101
		SF	1,089	1,319	1,319	2,637	2,637	2,637	2,637	2,637	2,637	2,637	0	22,186

* GFA per San Francisco Planning Code Sec. 102

OPEN SPACE AREA SUMMARY												
LEVEL	B	1	2	3	4	5	6	7	8	9	R	GSF
USABLE OPEN SPACE	860	0	0	0	0	0	0	0	0	0	1,370	2,230

DESCRIPTION
A STATE DENSITY BONUS LAW (SDBL) PROJECT CONSISTING OF RENTAL GROUP HOUSING.

PLANNING DATA

ASSESSOR PARCEL: BLOCK 0336 / LOT 006
 ZONING: RC-4
 HIGH DENSITY RESIDENTIAL-COMMERCIAL
 HEIGHT & BULK DISTRICT: 80-T
 LOT AREA: 4,667 +/- SF (0.107 AC)
 NOTE: SFPUC STORMWATER "SMALL PROJECT"
 SPECIAL USE DISTRICT: NORTH OF MARKET RESIDENTIAL SUBAREA 1
 HISTORIC DISTRICT: UPTOWN TENDERLOIN HISTORIC DISTRICT
 GROSS SQUARE FEET OF CONSTRUCTION: 36,860 SF
 GROSS FLOOR AREA: 35,090 SF (PER SFPC SEC. 102)

"RESIDENTIAL" GROSS FLOOR AREA: 32,722 SF
 (PER PLANNING DIRECTOR BULLETIN 6, JULY 2019)

UNITS: 101 (944 BDRM/AC)
 - MAX. TOTAL BEDS = 202

USABLE OPEN SPACE: 2,230 SF PROVIDED
 - (101) COMMON @ 48/3 SF = 1,616 SF REQ'D

BICYCLE PARKING: 45 CLASS I SPACES
 (45 REQ'D.)
 - PLUS (6) CLASS II PROVIDED
 (4 REQ'D.)

AUTOMOBILE PARKING: 0 SPACES
 -NONE REQUIRED

BUILDING DATA

STORIES: 9 + BASEMENT
 CONSTRUCTION TYPE: IB
 -FULLY SPRINKLERED
 BUILDING HEIGHT: 86'-0"
 - TOP MOST OCCUPIED STORY I.E., 9TH FLOOR,
 @ 74'-6" (<+75'-0") THEREFORE, NOT A HIGHRISE
 BUILDING USE: CONGREGATE RESIDENCE
 - 100% PRIVATELY FUNDED
 - SUBJECT TO S.F.B.C. CHAPTER 11A
 OCCUPANCY TYPE: R2



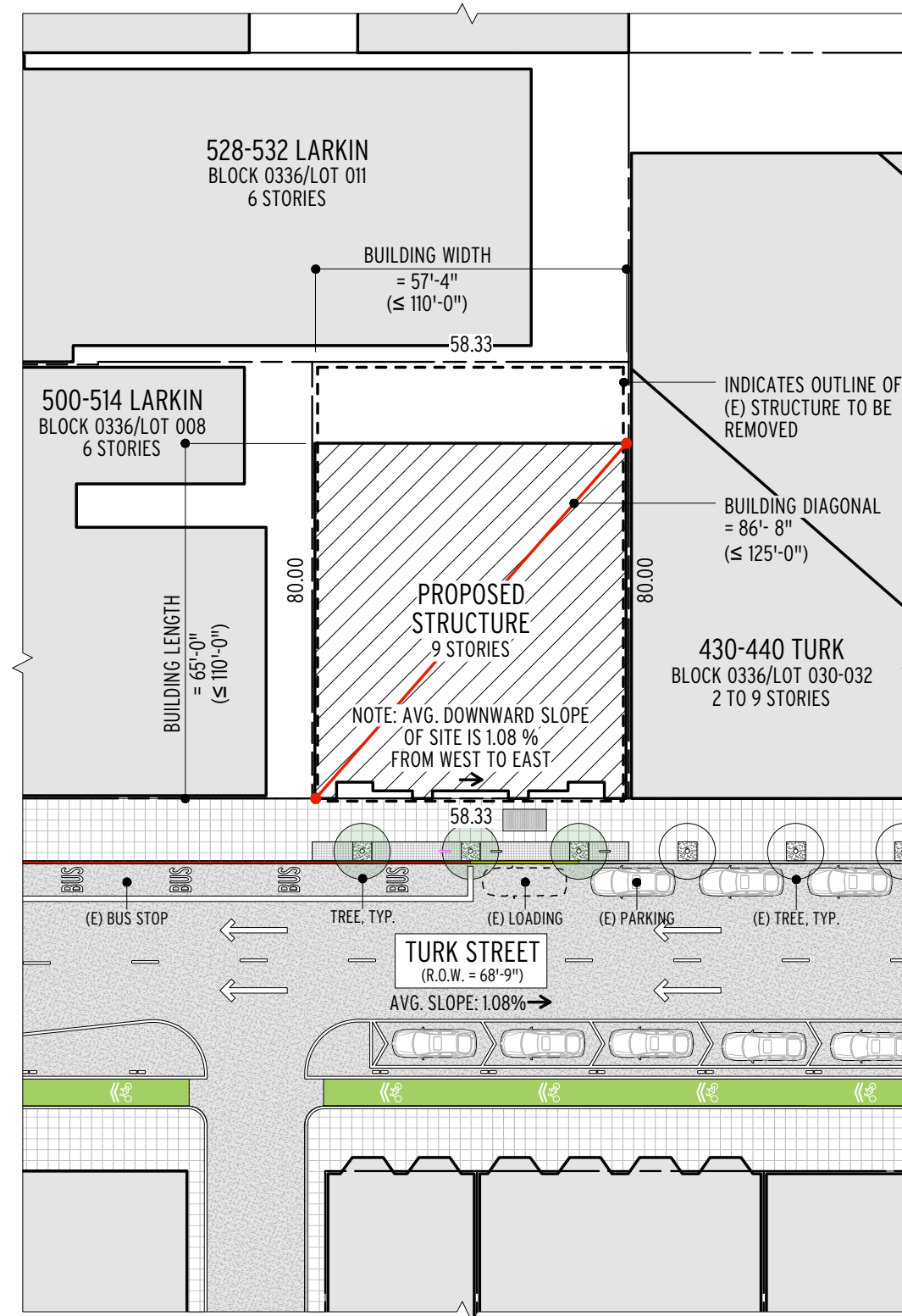

0' 30' 60' 90'

1" = 30'-0"

PROJECT NORTH

W E

S

SITE PLAN 01/28/2021

**MACY
ARCH
ITEC
TURE**

315 Linden Street San Francisco CA 94102 Tel 415 551 7630 www.macyarchitecture.com © 2021 Macy Architecture

All Rights Reserved.
The ideas represented
are the proprietary
intellectual property
of Macy Architecture.

PROJECT ENTITLEMENT APPLICATION (CU)

468 TURK STREET, SAN FRANCISCO, CA 94102
(BLOCK 0366 LOT 006)

PAGE 9 OF 18

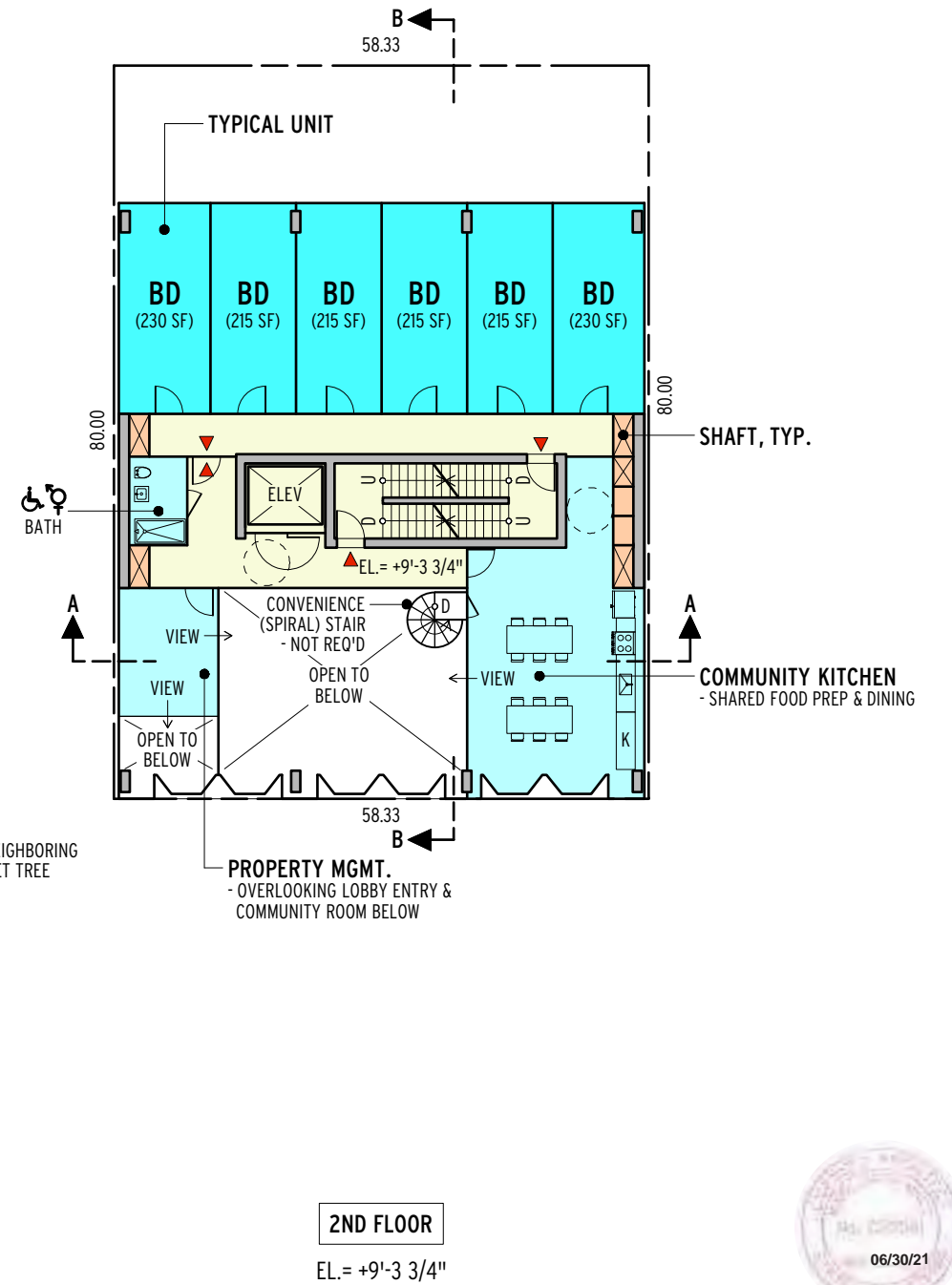
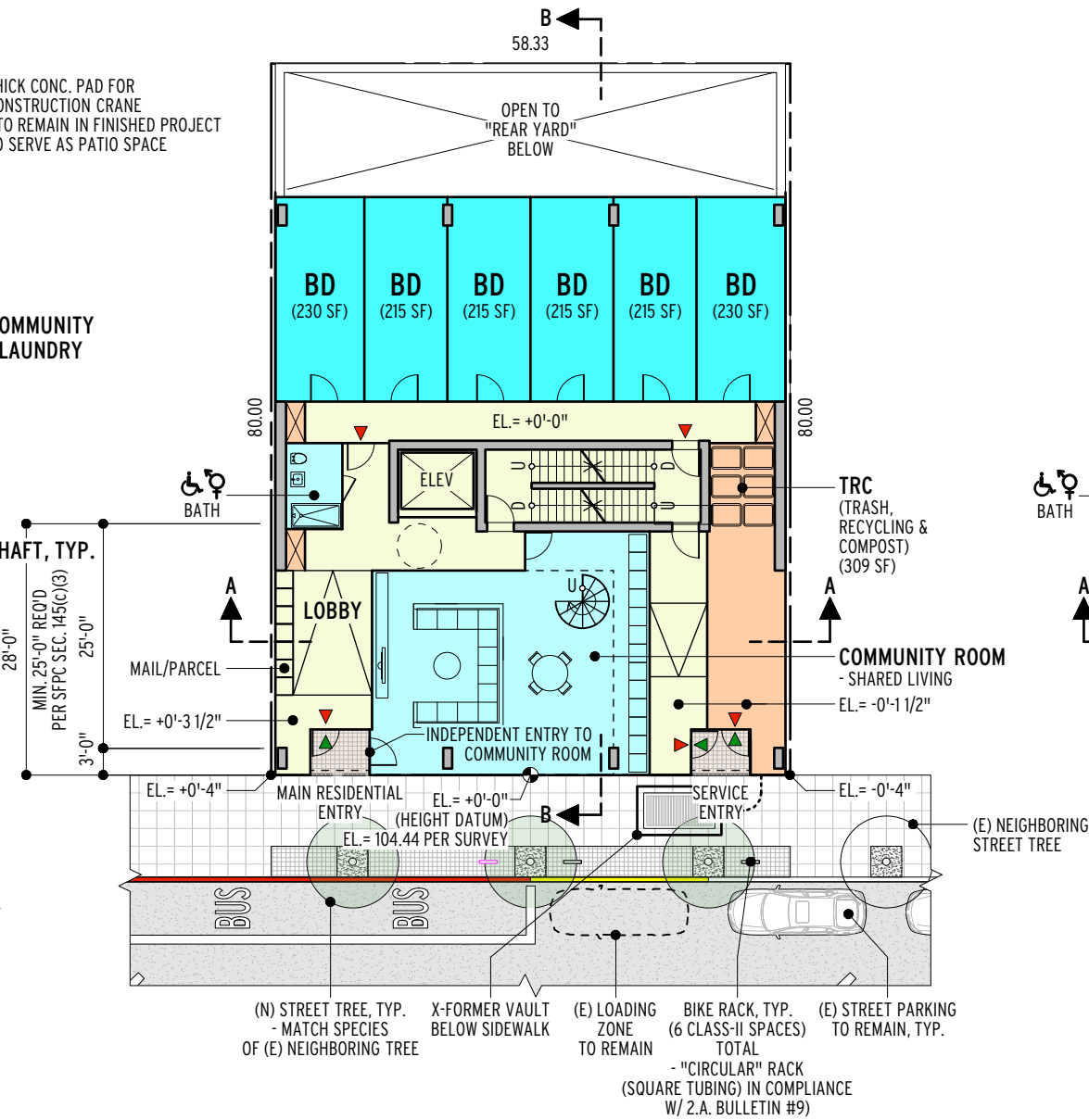
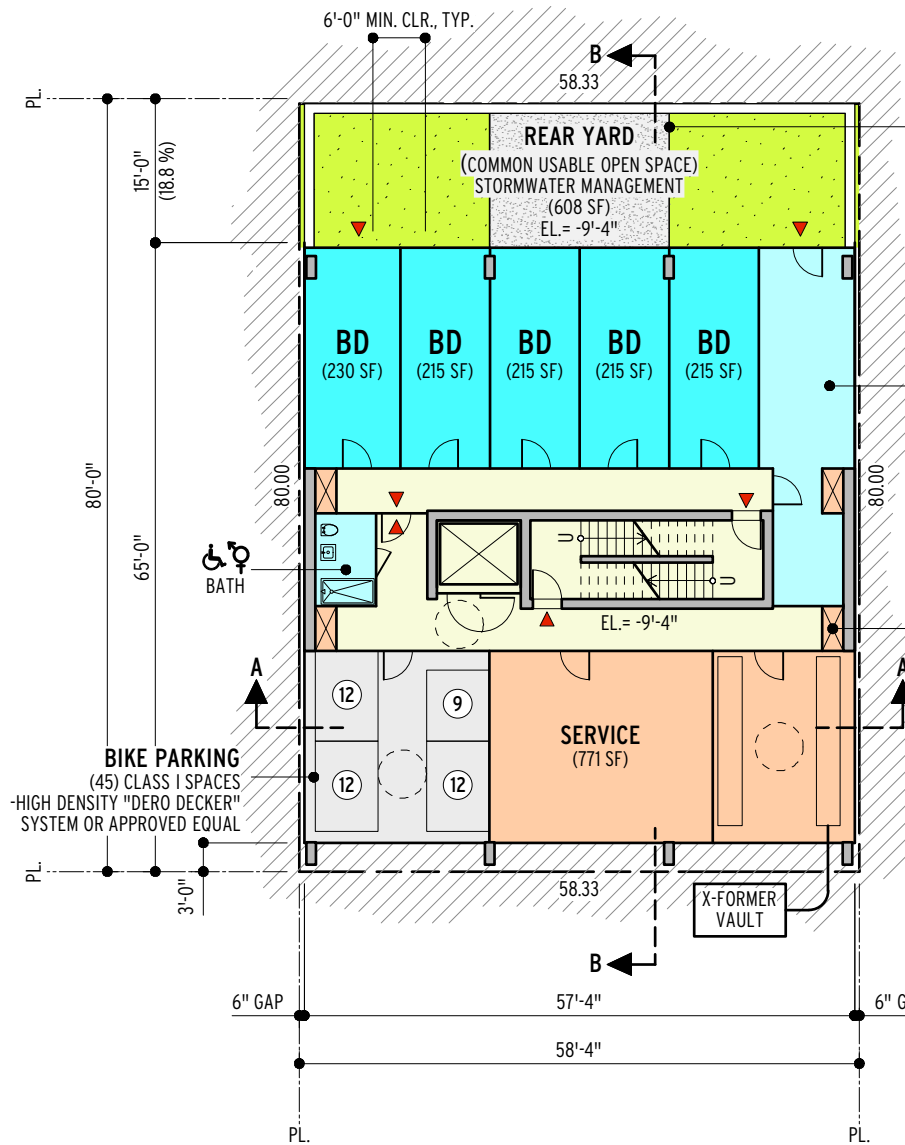

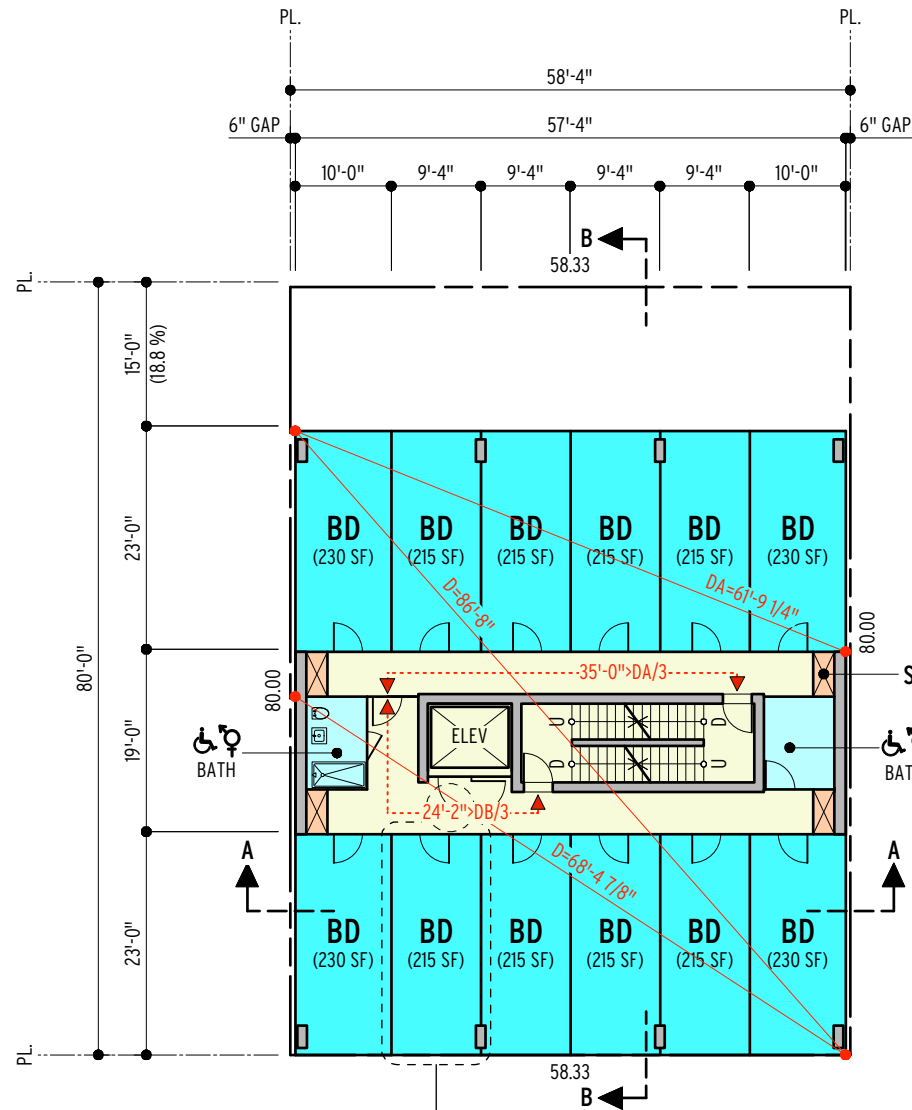

TYPICAL UNIT (SEE P. 15 & 16)

- SOFA-WALL BED
- SHOWER-TOILET COMPARTMENT W/ EXHAUST FAN
- LIMITED COOKING FACILITIES (PER Z.A. INTERPRETATION 209.2(a))
 - SINK
 - UNDERCOUNTER REFRIGERATOR/FREEZER
 - CONVECTION MICROWAVE W/ EXHAUST FAN
 - PLUG-IN 2-BURNER INDUCTION COOKTOP
 - STORAGE CABINETS
- WARDROBE
- DINING/WORKTABLE W/ 2-CHAIRS

3RD FLOOR (4TH,5TH,6TH,7TH, 8TH & 9TH SIM.)

EL. = +18'-7 1/2"/+27'-11 1/4"/+37'-3"/+46'-6 3/4"/+55'-10 1/2"/+65'-2 1/4"/+74'-6"

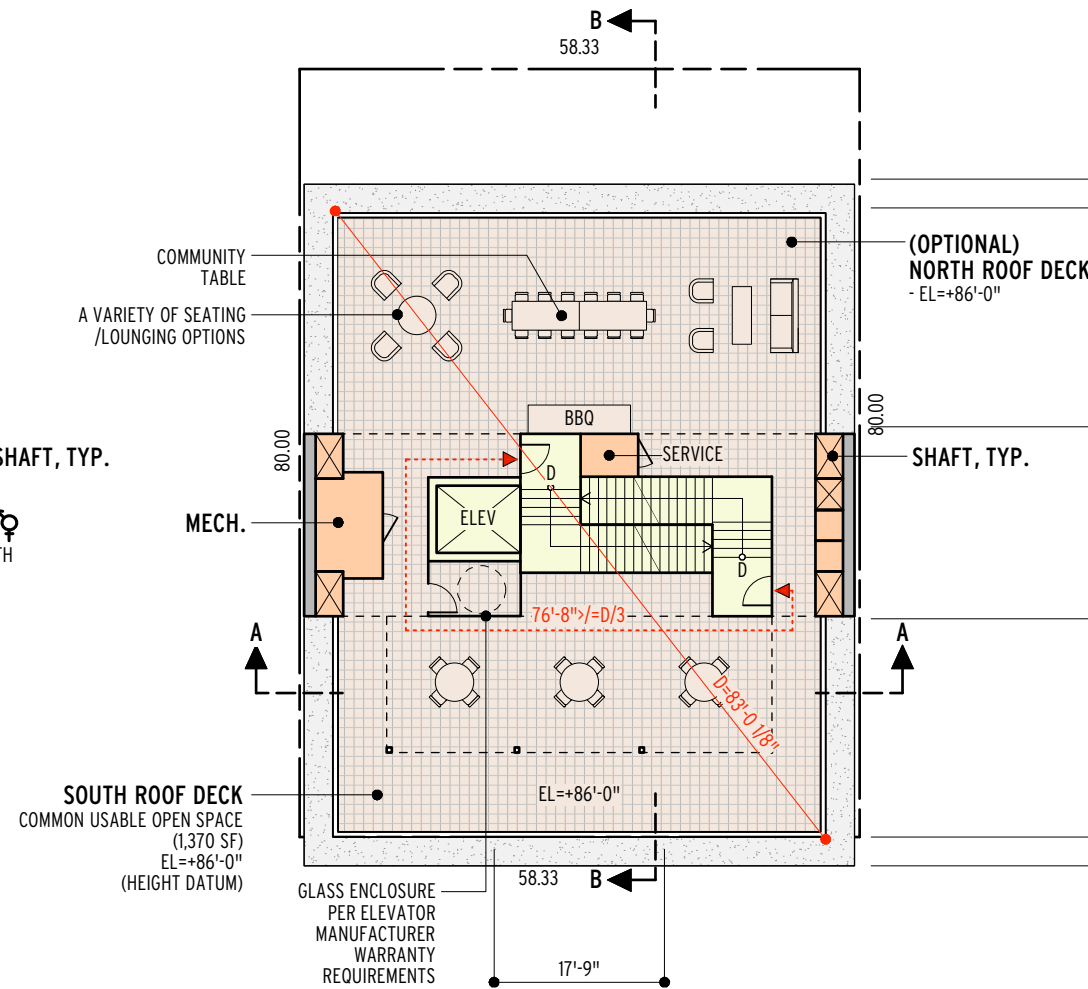

LOWER ROOF LEVEL

EL. = +86'-0"

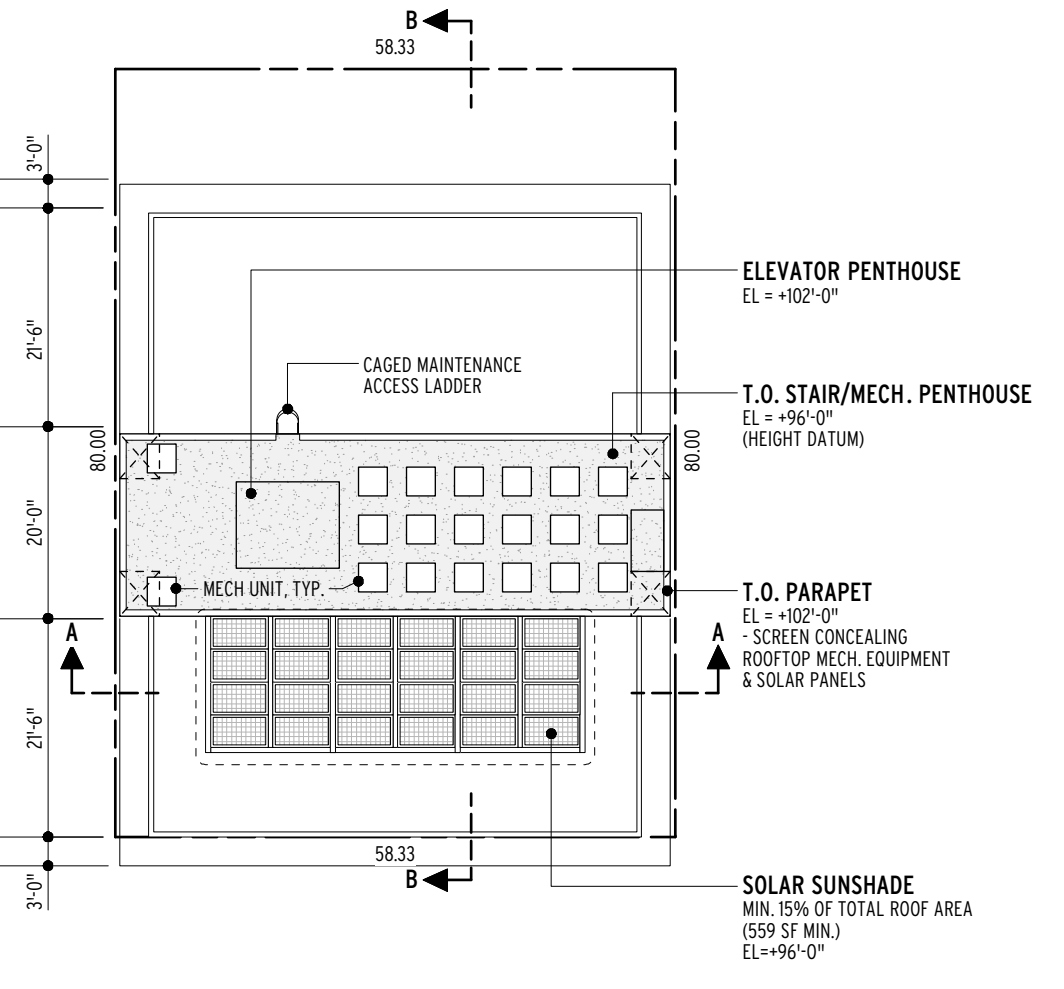

UPPER ROOF LEVEL

EL. = +96'-0"/+102'-0"

0' 5' 10' 20' 40' 60'

1" = 20'-0"



BONUS PROJECT PLAN DIAGRAMS

01/28/2021

**MACY
ARCHITECTURE**

315 Linden Street San Francisco CA 94102 Tel 415 551 7630 www.macyarchitecture.com © 2021 Macy Architecture

All Rights Reserved.
The ideas represented
are the proprietary
intellectual property
of Macy Architecture.

PROJECT ENTITLEMENT APPLICATION (CU)

468 TURK STREET, SAN FRANCISCO, CA 94102
(BLOCK 0366 LOT 006)

PAGE 11 OF 18



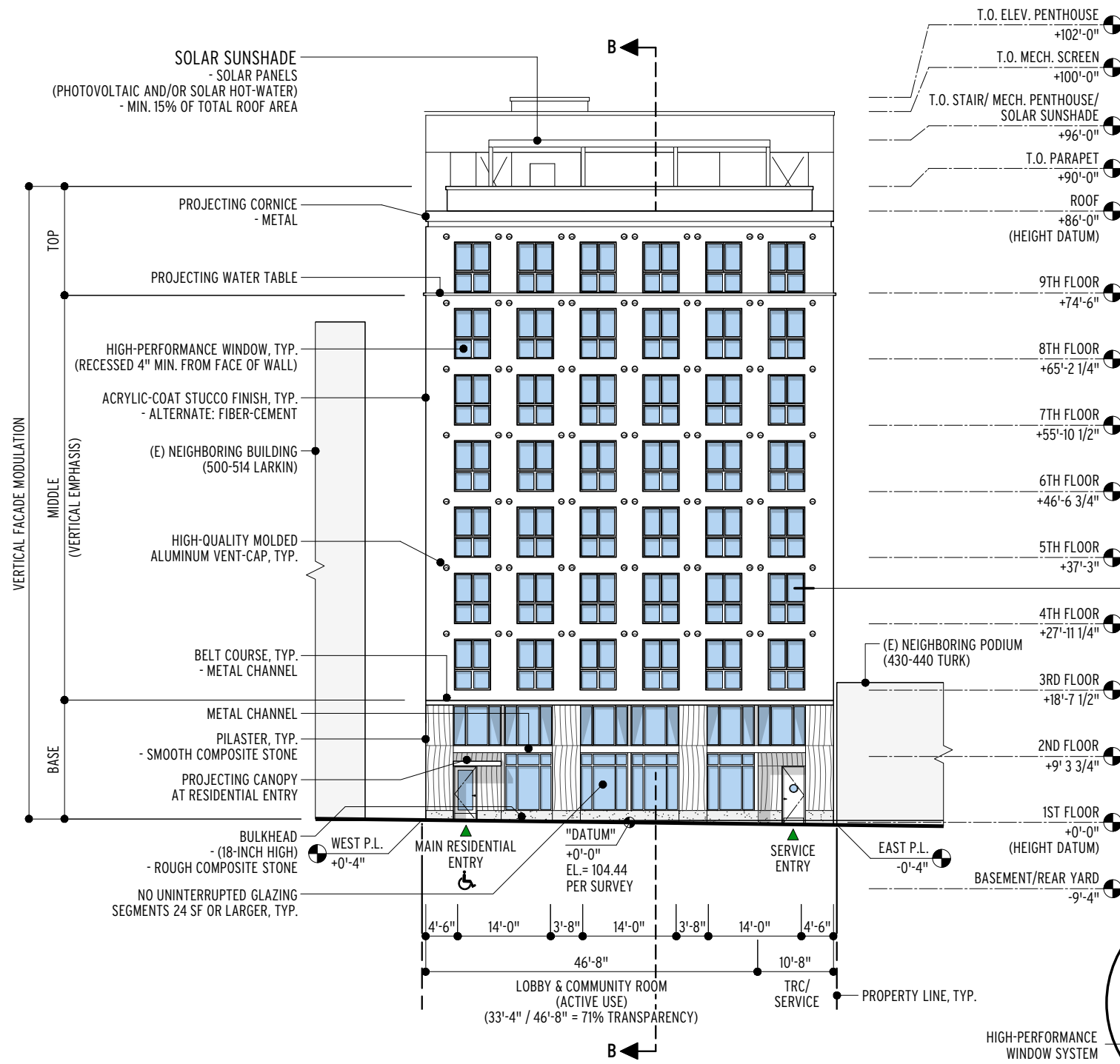

**SOUTH ELEVATION
(TURK STREET)**

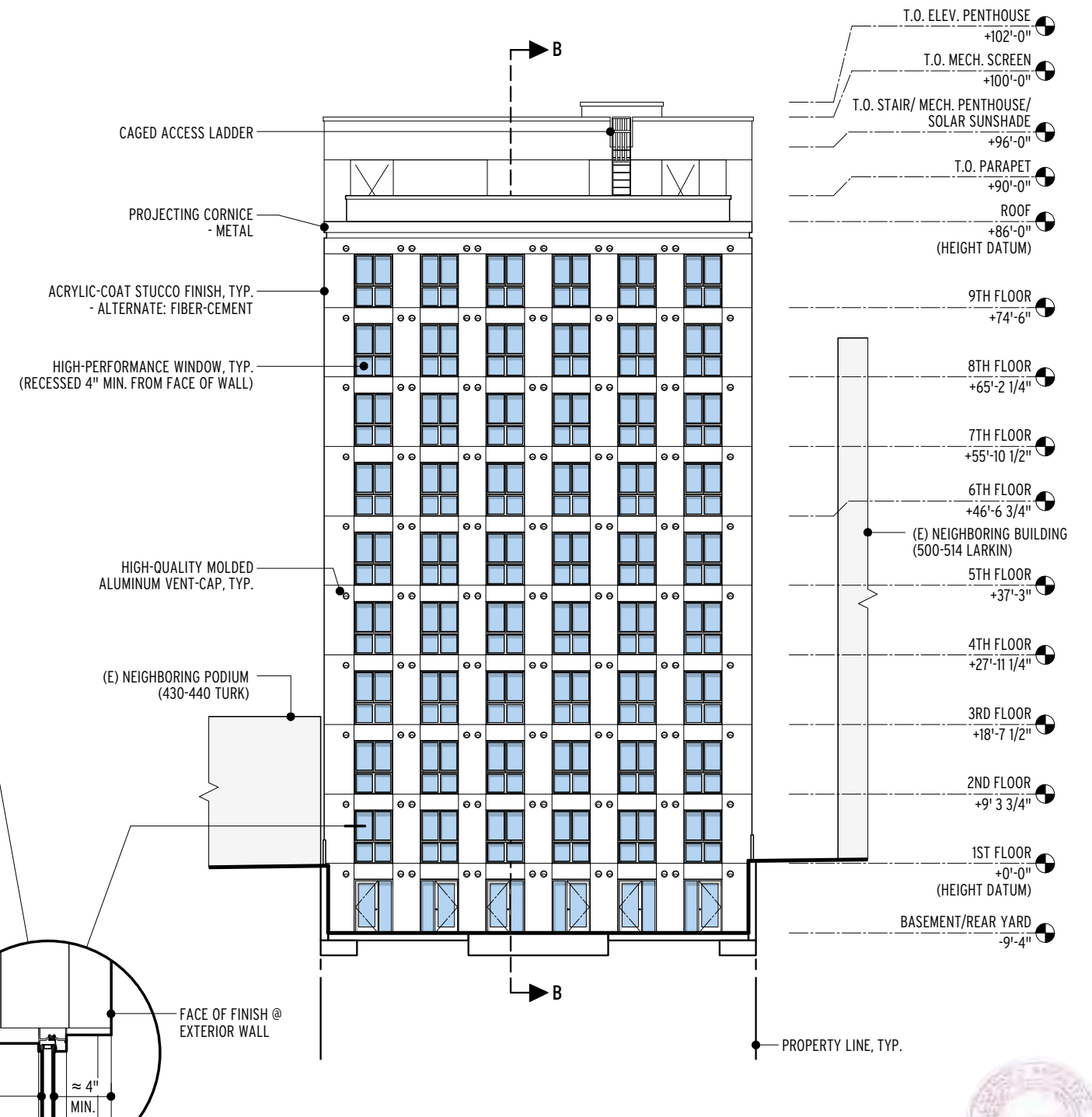

**NORTH ELEVATION
(REAR YARD)**

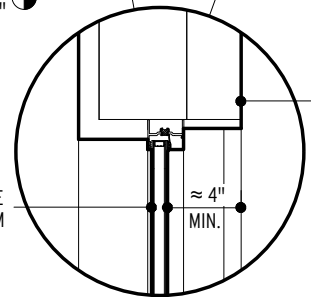

TYPICAL RECESSED WINDOW

0' 5' 10' 20' 40' 60'

1" = 20'-0"

BONUS PROJECT ELEVATIONS

01/28/2021

**M A C Y
A R C H
I T E C
T U R E**

315 Linden Street San Francisco CA 94102 Tel 415 551 7630 www.macyarchitecture.com © 2021 Macy Architecture

All Rights Reserved.
The ideas represented
are the proprietary
intellectual property
of Macy Architecture.

PROJECT ENTITLEMENT APPLICATION (CU)

468 TURK STREET, SAN FRANCISCO, CA 94102
(BLOCK 0366 LOT 006)

PAGE 12 OF 18



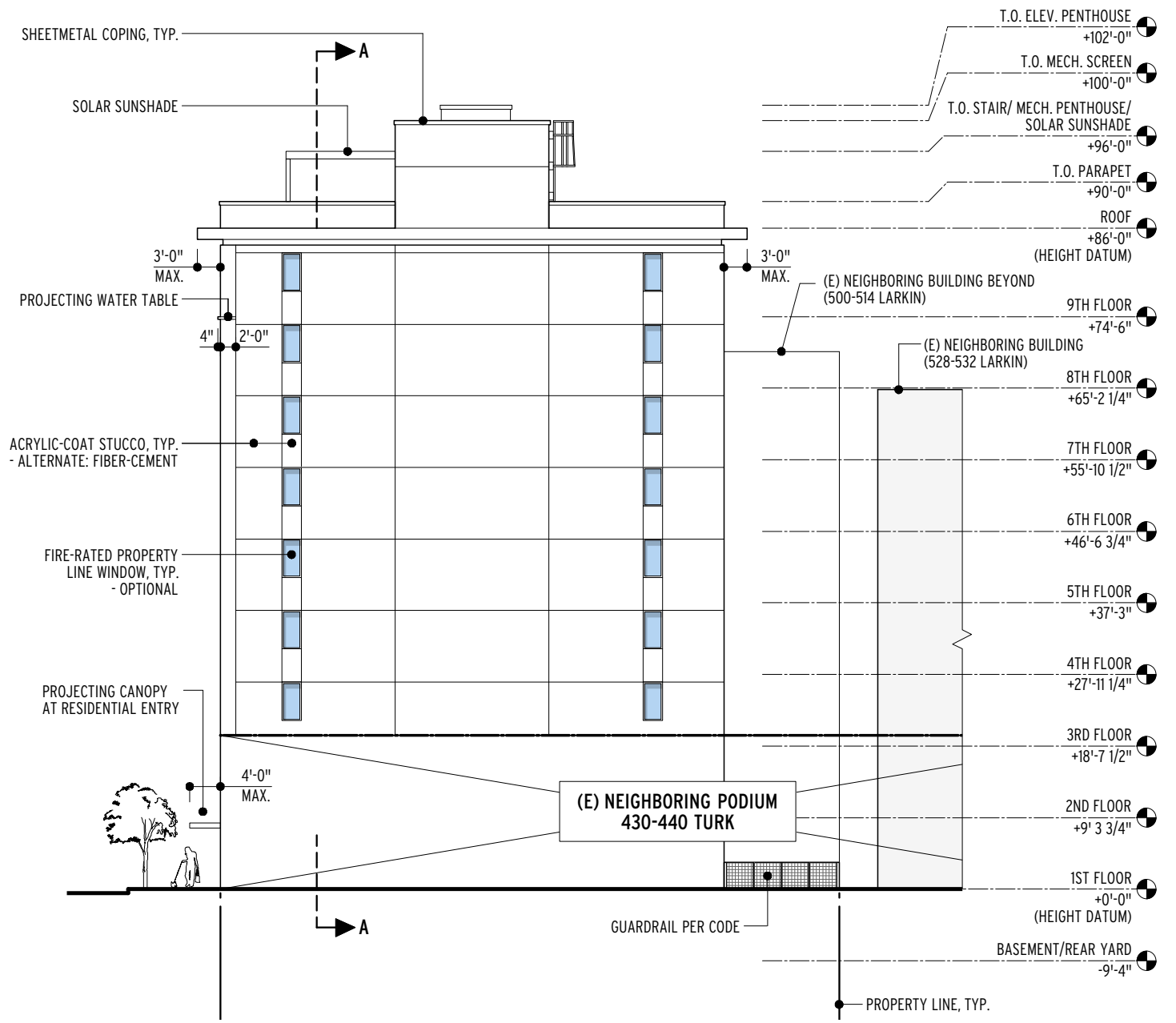
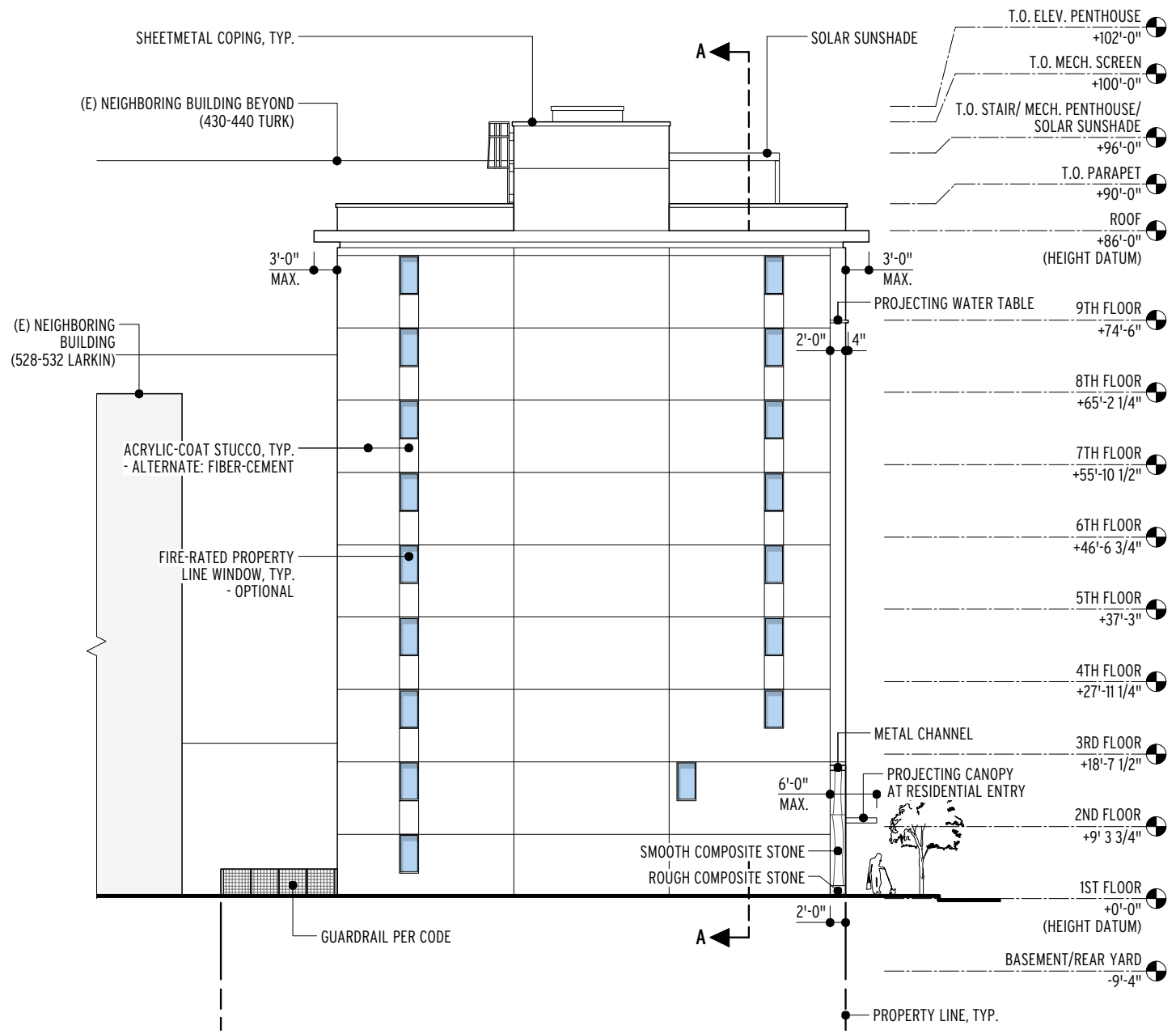

0' 5' 10' 20' 40' 60'

1" = 20'-0"

BONUS PROJECT ELEVATIONS 01/28/2021

**M A C Y
A R C H
I T E C
T U R E**

315 Linden Street San Francisco CA 94102 Tel 415 551 7630 www.macyarchitecture.com

All Rights Reserved. The ideas represented are the proprietary intellectual property of Macy Architecture.

© 2021 Macy Architecture

PROJECT ENTITLEMENT APPLICATION (CU)

468 TURK STREET, SAN FRANCISCO, CA 94102 (BLOCK 0366 LOT 006)

PAGE 13 OF 18



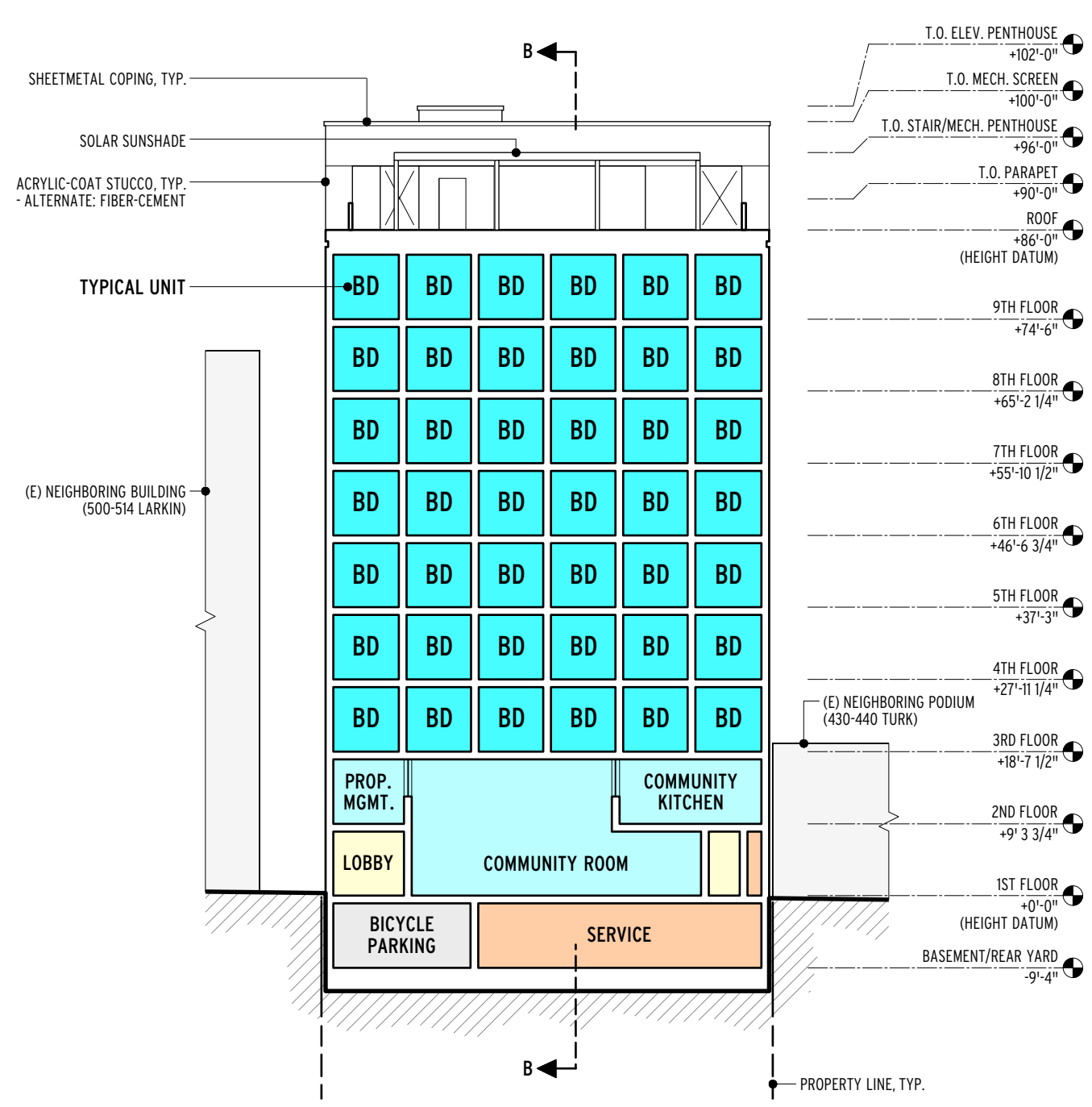

SECTION "A-A"

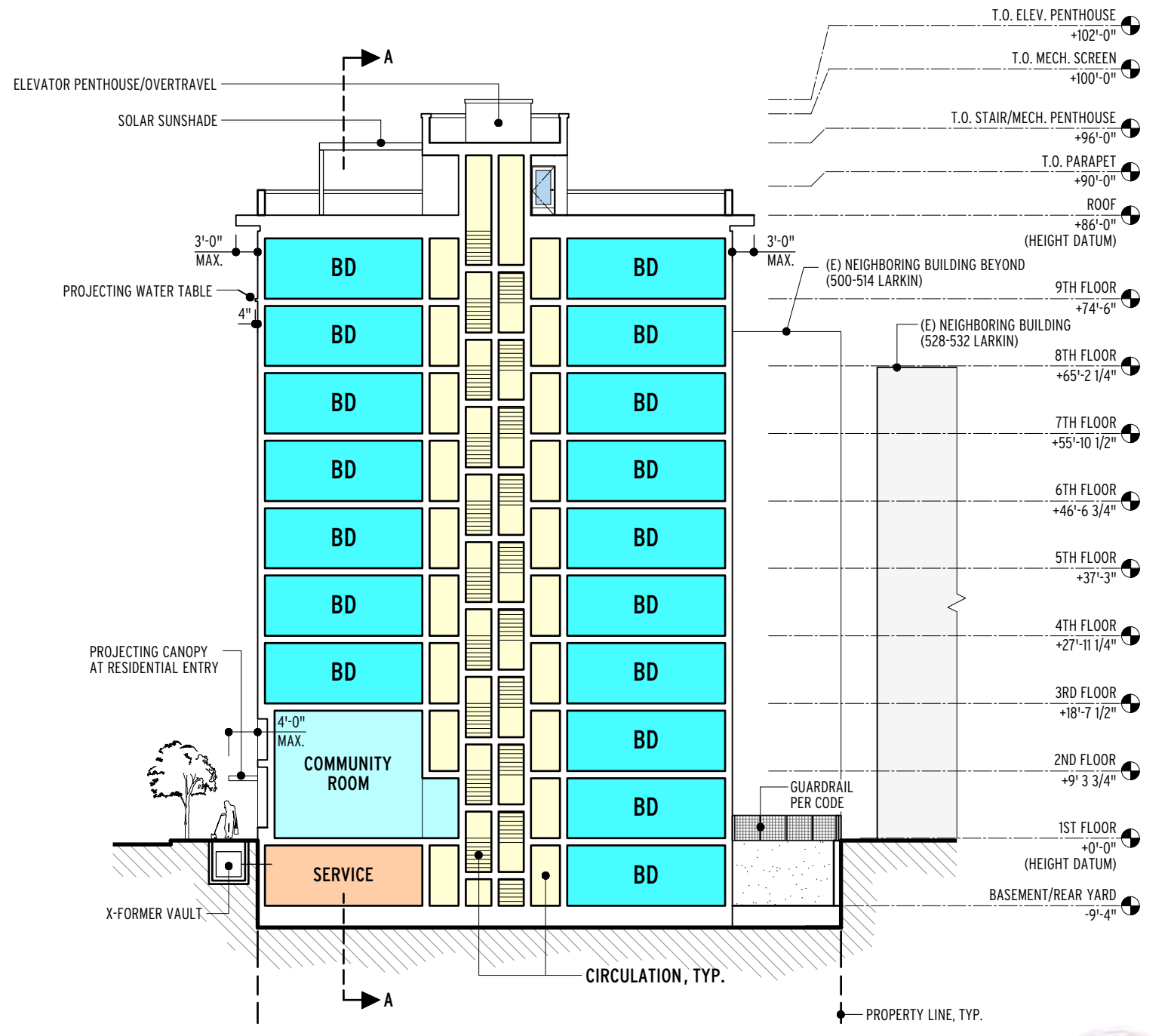

SECTION "B-B"

0' 5' 10' 20' 40' 60'

1" = 20'-0"

BONUS PROJECT SECTIONS

01/28/2021

**M A C Y
A R C H
I T E C
T U R E**

315 Linden Street San Francisco CA 94102 Tel 415 551 7630 www.macyarchitecture.com © 2021 Macy Architecture

All Rights Reserved.
The ideas represented
are the proprietary
intellectual property
of Macy Architecture.

PROJECT ENTITLEMENT APPLICATION (CU)

468 TURK STREET, SAN FRANCISCO, CA 94102
(BLOCK 0366 LOT 006)

PAGE 14 OF 18



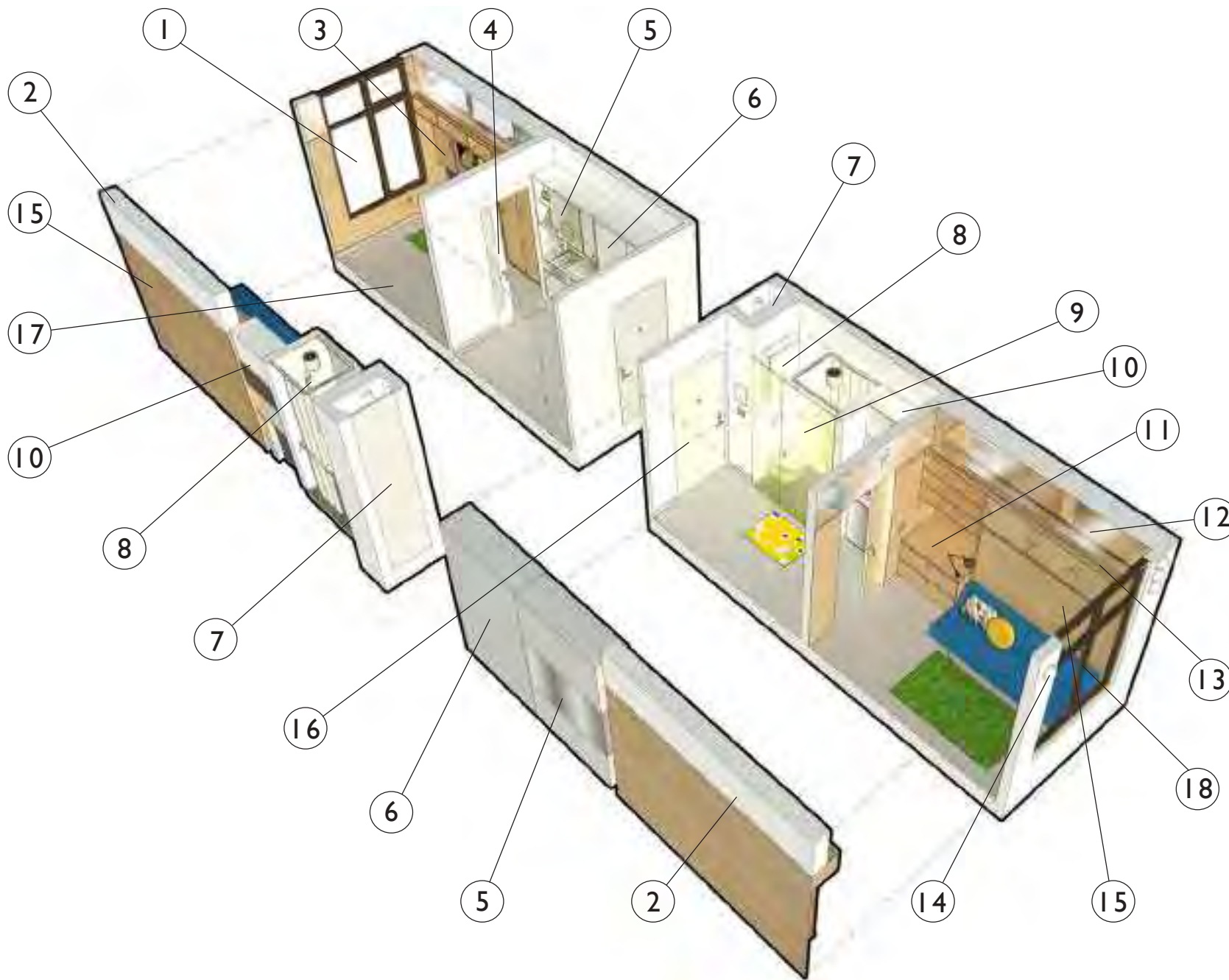

1. WINDOW SYSTEM

- HIGH-PERFORMANCE THERMAL ALUMINUM
- DARK BRONZE ANODIZED

2. MECHANICAL SOFFIT

- ENERGY RECOVERY VENTILATOR
- MERV 13 FILTRATION
- FIRE SPRINKLER PIPING
- SUB-METERING OF ALL UTILITIES

3. TV / SCREEN CABINET

- UPPER SHELVES
- SCREEN-HIDING PANELS
- FOLD-DOWN TABLE/DESK

4. SLIDING DOOR

- WITH INSET MIRROR

5. SINK / STORAGE CABINET

- UPPER CABINET W/ ETCHED MIRROR SLIDING DOORS & OPEN-BOTTOMED DISH-DRYING/ STORAGE SHELF
- CUSTOM S.S. SINK W/ INTEGRAL DRAIN BOARD & SLIDING, FLUSH CUTTING BOARD

6. WARDROBE / STORAGE CABINET

- WARDROBE/STORAGE CABINET W/ BI-PASSING SOLID-SURFACE DOOR PANELS

7. 2-HOUR FIRE-RATED SHAFT

- 90-MINUTE FIRE-RATE DOOR
- FLOOR-TO-CEILING FOR MAXIMUM ACCESS

8. TOILET / SHOWER COMPARTMENT

- WALL-HUNG TOILET W/ IN-WALL TANK
- SEMI-RECESSED STORAGE CABINET & WALL NICHE
- ADJUSTABLE-HEIGHT SHOWER HEAD
- GRAB/TOWEL/TOILETRIES BAR
- REMOVEABLE S.S. QUICK-DRY FLOOR GRATE OVER CUSTOM S.S. SHOWER PAN & FLOOR DRAIN

9. FIXED & SLIDING PANELS

- ACID-ETCHED FINGERPRINT FREE OBSCURE GLASS

10. PANTRY

- UPPER STORAGE CABINET
- MICROWAVE/CONVECTION WITH BUILT-IN LIGHT & EXHAUST FAN
- COUNTERTOP (+ PLUG-IN PORTABLE INDUCTION COOKTOP)
- UNDER-COUNTER REFRIGERATOR/FREEZER

11. DRESSER / STORAGE CABINET

- UPPER SHELVES OVER DRAWERS

12. CLERESTORY MIRRORS

- VISUAL EXPANSION OF SPACE

13. DIMMABLE LED INDIRECT LIGHT FIXTURE WITHIN COVE

- UPLIGHTING MAKING THE ENTIRE CEILING A REFLECTOR

14. MECHANICAL VENT CAP

- ANODIZED ALUMINUM

15. FOLD-DOWN SOFA / WALL-BED

- WITH UPPER STORAGE CABINET

16. 20-MINUTE FIRE-RATED ENTRY DOOR

- WITH ADA-COMPLIANT "DOORSCOPE" VIEWER

17. SLIMTECH CERAMIC FLOORING

- SUPER-DURABLE (FLOOD PROOF)
- LIGHTWEIGHT, LOW/NO MAINTENANCE

18. BIG WINDOW

- INCREASE SENSE OF SPACIOUSNESS & CONNECTION TO OUTDOORS
- MAXIMIZE NATURAL LIGHT
- MODULATE PRIVACY WITH TOP/DOWN - BOTTOM/UP SHADE



01/28/2021



GOOD MORNING



OPEN



GOOD AFTERNOON



CLOSED



GOOD EVENING



01/28/2021

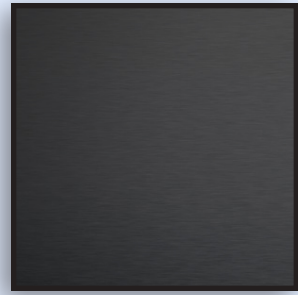

METAL

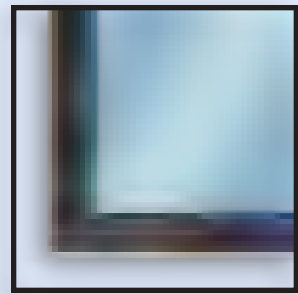

WINDOW SYSTEM
- HIGH PERFORMANCE

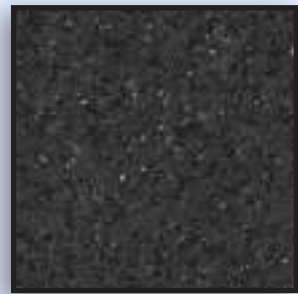

ROUGH COMPOSITE STONE



ACRYLIC COAT STUCCO
FINISH
- INTEGRALLY-COLORED



ALUMINUM VENT CAP
- AIR INTAKE & EXHAUST



SMOOTH COMPOSITE STONE





STREET VIEW 01/28/2021

Land Use Information

Project Address: 468 Turk St
Record No.: 2019-020740PRJ

	EXISTING	PROPOSED	NET NEW
GROSS SQUARE FOOTAGE (GSF)			
Parking GSF			
Residential GSF	0	32,775	32,775
Retail/Commercial GSF	0	32,775	32,775
Usable Open Space	0	1,978	1,978
Public Open Space			
TOTAL GSF			
	EXISTING	NET NEW	TOTALS
PROJECT FEATURES (Units or Amounts)			
Dwelling Units - Affordable	0	17	17
Dwelling Units - Market Rate	0	84	84
Dwelling Units - Total	0	101	101
Number of Buildings	0	1	1
Number of Stories	0	9	9
Parking Spaces			
Loading Spaces	1	1	0
Bicycle Spaces	0	45	45
Car Share Spaces			

	EXISTING	PROPOSED	NET NEW
LAND USE - RESIDENTIAL			
Studio Units	0	0	0
One Bedroom Units	0	0	0
Two Bedroom Units	0	0	0
Three Bedroom (or +) Units	0	0	0
Group Housing - Rooms	0	101	101
Group Housing - Beds	0	202	202
SRO Units	0	0	0
Micro Units	0	0	0
Accessory Dwelling Units	0	0	0

Parcel Map



Sanborn Map*

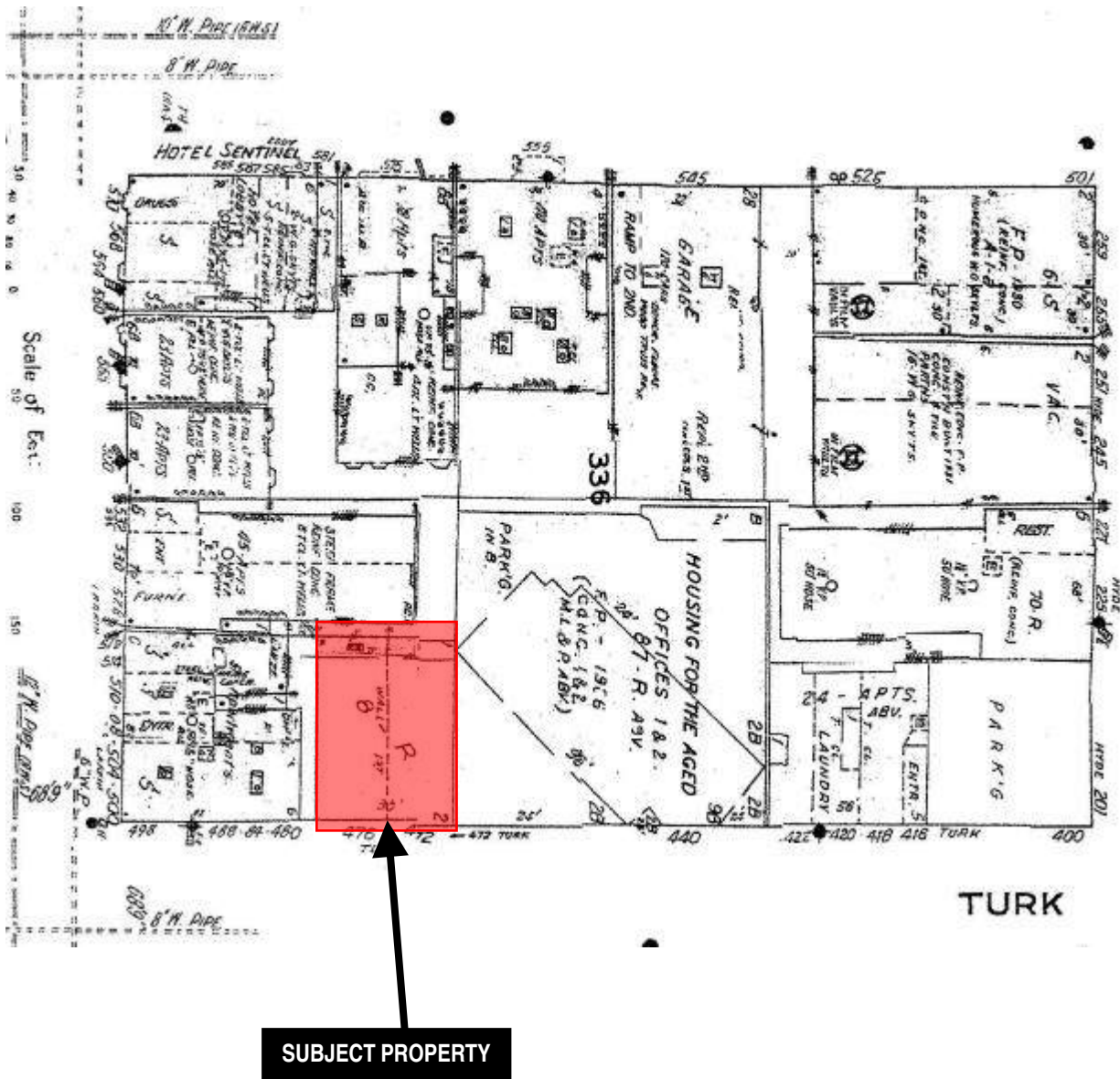

*The Sanborn Maps in San Francisco have not been updated since 1998, and this map may not accurately reflect existing conditions.



Conditional Use Authorization Hearing
Case Number 2019-020740CUA
468 Turk Street

Aerial Photo – View 1



SUBJECT PROPERTY



Aerial Photo – View 2



SUBJECT PROPERTY



Zoning Map

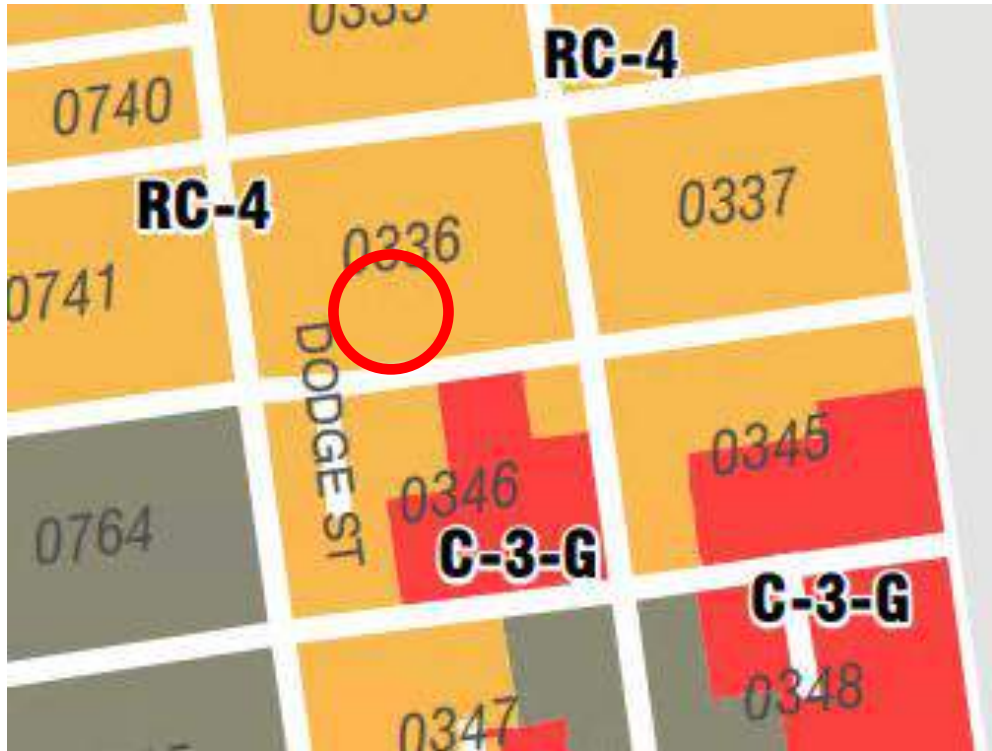

Site Photo



Conditional Use Authorization Hearing
Case Number 2019-020740CUA
468 Turk Street

COMPLIANCE WITH THE INCLUSIONARY AFFORDABLE HOUSING PROGRAM

PLANNING CODE SECTION 415, 417 & 419



February 05, 2021

Date

Nick Judd

I, _____,
do hereby declare as follows:

A The subject property is located at (address and block/lot):

468 Turk Street

Address

0336 / 006

Block / Lot

The subject property is located within the following Zoning District:

RC - 4

Zoning District

80-T

Height and Bulk District

North of Market Residential Sub-Area 1

Special Use District, if applicable

Is the subject property located in the SOMA NCT, North of Market Residential SUD, or Mission Area Plan?

Yes No

B The proposed project at the above address is subject to the *Inclusionary Affordable Housing Program*, Planning Code Section 415 and 419 et seq.

The Planning Case Number and/or Building Permit Number is:

2019-020740 PRJ

Planning Case Number

Building Permit Number

This project requires the following approval:

- Planning Commission approval (e.g. Conditional Use Authorization, Large Project Authorization)
- Zoning Administrator approval (e.g. Variance)
- This project is principally permitted.

The Current Planner assigned to my project within the Planning Department is:

Alexandra Kirby

Planner Name

A complete Environmental Evaluation Application or Project Application was accepted on:

January 21, 2020

Date

The project contains **101** total dwelling units and/o **group housing rooms.**

This project is exempt from the *Inclusionary Affordable Housing Program* because:

- This project is 100% affordable.
- This project is 100% student housing.

Is this project in an UMU Zoning District within the Eastern Neighborhoods Plan Area?

Yes No

(If yes, please indicate Affordable Housing Tier)

Is this project a HOME-SF Project?

Yes No

(If yes, please indicate HOME-SF Tier)

Is this project an Analyzed or Individually Requested State Density Bonus Project?

Yes No **Individually Requested**

UNIT MIX TABLES

Number of All Units in PRINCIPAL PROJECT:					
TOTAL UNITS:	SRO / Group Housing:	Studios:	One-Bedroom Units:	Two-Bedroom Units:	Three (or more) Bedroom Units:
101	101				

If you selected the On-site, Off-Site, or Combination Alternative, please fill out the applicable section below. The On-Site Affordable Housing Alternative is required for HOME-SF Projects pursuant to Planning Code Section 206.4. State Density Bonus Projects that have submitted an Environmental Evaluation Application prior to January 12, 2016 must select the On-Site Affordable Housing Alternative. State Density Bonus Projects that have submitted an Environmental Evaluation Application on or after to January 12, 2016 must select the Combination Affordable Housing Alternative to record the required fee on the density bonus pursuant to Planning Code Section 415.3. If the Project includes the demolition, conversion, or removal of any qualifying affordable units, please complete the Affordable Unit Replacement Section.

On-site Affordable Housing Alternative (Planning Code Section 415.6, 419.3, or 206.4): % of the unit total.

Number of Affordable Units to be Located ON-SITE:					
TOTAL UNITS:	SRO / Group Housing:	Studios:	One-Bedroom Units:	Two-Bedroom Units:	Three (or more) Bedroom Units:
LOW-INCOME	Number of Affordable Units	% of Total Units		AMI Level	
MODERATE-INCOME	Number of Affordable Units	% of Total Units		AMI Level	
MIDDLE-INCOME	Number of Affordable Units	% of Total Units		AMI Level	

Off-site Affordable Housing Alternative (Planning Code Section 415.7 or 419.3): % of the unit total.

Number of Affordable Units to be Located OFF-SITE:					
TOTAL UNITS:	SRO / Group Housing:	Studios:	One-Bedroom Units:	Two-Bedroom Units:	Three (or more) Bedroom Units:
Area of Dwellings in Principal Project (in sq. feet):		Off-Site Project Address:			
Area of Dwellings in Off-Site Project (in sq. feet):					
Off-Site Block/Lot(s):		Motion No. for Off-Site Project (if applicable):		Number of Market-Rate Units in the Off-site Project:	
AMI LEVELS:	Number of Affordable Units	% of Total Units		AMI Level	
	Number of Affordable Units	% of Total Units		AMI Level	
	Number of Affordable Units	% of Total Units		AMI Level	

UNIT MIX TABLES: CONTINUED

- Combination** of payment of a **fee**, **on-site affordable units**, or **off-site affordable units** with the following distribution:
 Indicate what percent of each option will be implemented (from 0% to 99%) and the number of on-site and/or off-site below market rate units for rent and/or for sale.
1. On-Site % of affordable housing requirement. **(i.e., 25% of "Base Density" of 67 Units; accordingly, 67 Units x .25 = 16.75; round up to 17 Units)**

If the project is a State Density Bonus Project, please enter "100%" for the on-site requirement field and complete the Density Bonus section below.

Number of Affordable Units to be Located ON-SITE:					
TOTAL UNITS: 17	SRO / Group Housing: 17	Studios:	One-Bedroom Units:	Two-Bedroom Units:	Three (or more) Bedroom Units:

2. Off-Site % of affordable housing requirement.

Number of Affordable Units to be Located OFF-SITE:					
TOTAL UNITS: Not Applicable.	SRO / Group Housing:	Studios:	One-Bedroom Units:	Two-Bedroom Units:	Three (or more) Bedroom Units:
Area of Dwellings in Principal Project (in sq. feet):		Off-Site Project Address:			
Area of Dwellings in Off-Site Project (in sq. feet):					
Off-Site Block/Lot(s):		Motion No. for Off-Site Project (if applicable):		Number of Market-Rate Units in the Off-site Project:	

Income Levels for On-Site or Off-Site Units in Combination Projects:			
AMI LEVELS:	Number of Affordable Units 10	% of Total Units 15% (of 67 Base Units)	AMI Level 50%
AMI LEVELS:	Number of Affordable Units 3	% of Total Units 5% (of 67 Base Units; round down)	AMI Level 80%
AMI LEVELS:	Number of Affordable Units 4	% of Total Units 5% (of 67 Base Units; round up)	AMI Level 110%

3. Fee % of affordable housing requirement.

Is this Project a State Density Bonus Project? Yes No

If yes, please indicate the bonus percentage, up to 35% , and the number of bonus units and the bonus amount of residential gross floor area (if applicable)

I acknowledge that Planning Code Section 415.4 requires that the Inclusionary Fee be charged on the bonus units or the bonus residential floor area.

Affordable Unit Replacement: Existing Number of Affordable Units to be Demolished, Converted, or Removed for the Project					
TOTAL UNITS: Not Applicable.	SRO / Group Housing:	Studios:	One-Bedroom Units:	Two-Bedroom Units:	Three (or more) Bedroom Units:

This project will replace the affordable units to be demolished, converted, or removed using the following method:

- On-site Affordable Housing Alternative
- Payment of the Affordable Housing Fee prior to the first construction document issuance
- Off-site Affordable Housing Alternative (Section 415.7)
- Combination of payment of the Affordable Housing Fee and the construction of on-site or off-site units (Section 415.5)

Contact Information and Declaration of Sponsor of PRINCIPAL PROJECT

Turk Street LLC

Company Name

Nick Judd

Name (Print) of Contact Person

8 Dellbrook Avenue

San Francisco, CA 94131

Address

City, State, Zip

(415) 832-9171

nickjudd@hotmail.com

Phone / Fax

Email

I am a duly authorized agent or owner of the subject property. I declare under penalty of perjury under the laws of the State of California that the foregoing is true and correct. I hereby declare that the information herein is accurate to the best of my knowledge and that I intend to satisfy the requirements of Planning Code Section 415 as indicated above.

Sign Here

Signature:



Name (Print), Title:

Nick Judd – Managing Partner

Executed on this day in:

Location:

San Francisco, CA

Date:

February 05, 2021

Contact Information and Declaration of Sponsor of OFF-SITE PROJECT (If Different)

Company Name

Name (Print) of Contact Person

Address

City, State, Zip

Phone / Fax

Email

I hereby declare that the information herein is accurate to the best of my knowledge and that I intend to satisfy the requirements of Planning Code Section 415 as indicated above.

Sign Here

Signature:

Name (Print), Title:

From: Grob, Carly (CPC) carly.grob@sfgov.org 

Subject: Re: 468 TURK -2/25 hearing materials

Date: February 3, 2021 at 4:56 PM

To: Mark Macy markm@macyarchitecture.com

Cc: Kirby, Alexandra (CPC) alexandra.kirby@sfgov.org, Cameron Maddern cammaddern@gmail.com, Daniela danielamaddern@hotmail.com, Nick Judd nickijudd@hotmail.com, Keith Dubinsky keithd@macyarchitecture.com, Robert Gilson robertg@macyarchitecture.com, Craciun, Florentina (CPC) florentina.craciun@sfgov.org

CG

Hi Mark,

It would be 25% applied to the base density of 67 units. You can't reduce any further because you need the full 15% at very low income to qualify for the 50% bonus. You can calculate the remaining fee using [Example 1 in DB 6](#).

25% x 67 = 17 units

50% AMI:

$15/25 = .6$

$.6 \times 17 = 10.2$ or 10 units

80% AMI

$5/25 = .2$

$.2 \times 17 = 3.4$ or 3 units (rounded down – rounding up would result in one higher unit)

110% AMI

$5/25 = .2$

$.2 \times 17 = 3.4$ or 4 units (rounded up highest remainder – rounding down result in one lower unit than required)

From: Mark Macy <markm@macyarchitecture.com>

Date: Wednesday, February 3, 2021 at 11:00 AM

To: Grob, Carly (CPC) <carly.grob@sfgov.org>

Cc: Kirby, Alexandra (CPC) <alexandra.kirby@sfgov.org>, Cameron Maddern <cammaddern@gmail.com>, Daniela <danielamaddern@hotmail.com>, Nick Judd <nickijudd@hotmail.com>, Keith Dubinsky <keithd@macyarchitecture.com>, Robert Gilson <robertg@macyarchitecture.com>, Craciun, Florentina (CPC) <florentina.craciun@sfgov.org>

Subject: Re: 468 TURK -2/25 hearing materials

Carly,

Thx,

Can you please verify the minimum number of Units (and their AMI distribution of 50%AMI / 80%AMI/ 110%AMI) that we need to provide on-site in order to achieve our total of (101) Units?

Best,

Mark

On Tue, Feb 2, 2021 at 6:13 PM Grob, Carly (CPC) <carly.grob@sfgov.org> wrote:

Hi Mark,

I've attached a draft Regulatory Agreement template. Please use track changes as you modify the template. Once you have a revised copy, please send that version to me and I will review with the City Attorney.

COMPLIANCE WITH THE INCLUSIONARY AFFORDABLE HOUSING PROGRAM



Date: October 24, 2018

To: Applicants subject to Planning Code Section 415 and 419: *Inclusionary Affordable Housing Program*

From: San Francisco Planning Department

Re: **Compliance with the Inclusionary Affordable Housing Program**

All projects that include 10 or more dwelling units must participate in the *Inclusionary Affordable Housing Program* contained in Planning Code Sections 415 and 419. Every project subject to the requirements of Planning Code Section 415 or 419 is required to pay the Affordable Housing Fee. A project may be eligible for an Alternative to the Affordable Housing Fee. All projects that can demonstrate that they are eligible for an Alternative to the Affordable Housing Fee must provide necessary documentation to the Planning Department and Mayor's Office of Housing and Community Development.

At least 30 days before the Planning Department and/or Planning Commission can act on the project, this Affidavit for Compliance with the Inclusionary Affordable Housing Program must be completed. Please note that this affidavit is required to be included in Planning Commission packets and therefore, must comply with packet submittal guidelines.

The inclusionary requirement for a project is determined by the date that the Environmental Evaluation Application (EEA) or Project Application (PRJ) was deemed complete by the Department ("EEA/PRJ accepted date"). There are different inclusionary requirements for smaller projects (10-24 units) and larger projects (25+ units). Please use the attached charts to determine the applicable requirement. Charts 1-3 include two sections. The first section is devoted to projects that are subject to Planning Code Section 415. The second section covers projects that are located in the Urban Mixed Use (UMU) Zoning District and certain projects within the Mission Neighborhood Commercial Transit District that are subject to Planning Code Section 419. Please use the applicable form and contact Planning staff with any questions.

For projects with complete EEA's/PRJ's accepted on or after January 12, 2016, the Inclusionary Affordable Housing Program requires the provision of on-site and off-site affordable units at a mix of income levels. The number of units provided at each income level depends on the project tenure, EEA/PRJ accepted date, and the applicable schedule of on-site rate increases. Income levels are defined as a percentage of the Area Median Income (AMI), for low-income, moderate-income, and middle-income units, as shown in Chart 5. Projects with a complete EEA accepted prior to January 12, 2016 must provide the all of the inclusionary units at the low income AMI. **Any project with 25 units or more and with a complete EEA accepted between January 1, 2013 and January 12, 2016 must obtain a site or building permit by December 7, 2018, or will be subject to higher Inclusionary Housing rates and requirements. Generally, rental projects with 25 units or more be subject to an 18% on-site rate and ownership projects with 25 units or more will be subject to a 20% on-site rate.**

Summary of requirements. Please determine what requirement is applicable for your project based on the size of the project, the zoning of the property, and the date that a complete Environmental Evaluation Application (EEA) or complete Project Application (PRJ) was submitted deemed complete by Planning Staff. Chart 1-A applies to all projects throughout San Francisco with EEA's accepted prior to January 12, 2016, whereas Chart 1-B specifically addresses UMU (Urban Mixed Use District) Zoning Districts. Charts 2-A and 2-B apply to rental projects and Charts 3-A and 3-B apply to ownership projects with a complete EEA/PRJ accepted on or after January 12, 2016. Charts 4-A and 4-B apply to three geographic areas with higher inclusionary requirements: the North of Market Residential SUD, SOMA NCT, and Mission Area Plan.

The applicable requirement for projects that received a first discretionary approval prior to January 12, 2016 are those listed in the "EEA accepted before 1/1/13" column on Chart 1-A.

CHART 1-A: Inclusionary Requirements for all projects with Complete EEA accepted before 1/12/2016

	<i>Complete EEA Accepted: →</i>	<i>Before 1/1/13</i>	<i>Before 1/1/14</i>	<i>Before 1/1/15</i>	<i>Before 1/12/16</i>
On-site					
10-24 unit projects		12.0%	12.0%	12.0%	12.0%
25+ unit projects		12.0%	13.0%	13.5%	14.5%
Fee or Off-site					
10-24 unit projects		20.0%	20.0%	20.0%	20.0%
25+ unit projects at or below 120'		20.0%	25.0%	27.5%	30.0%
25+ unit projects over 120' in height *		20.0%	30.0%	30.0%	30.0%

*except buildings up to 130 feet in height located both within a special use district and within a height and bulk district that allows a maximum building height of 130 feet, which are subject to the requirements of 25+ unit projects at or below 120 feet.

CHART 1-B: Requirements for all projects in UMU Districts with Complete EEA accepted before 1/12/2016

Please note that certain projects in the SOMA Youth and Family SUD and Western SOMA SUD also rely upon UMU requirements.

	<i>Complete EEA Accepted: →</i>	<i>Before 1/1/13</i>	<i>Before 1/1/14</i>	<i>Before 1/1/15</i>	<i>Before 1/12/16</i>
On-site UMU					
Tier A 10-24 unit projects		14.4%	14.4%	14.4%	14.4%
Tier A 25+ unit projects		14.4%	15.4%	15.9%	16.4%
Tier B 10-24 unit projects		16.0%	16.0%	16.0%	16.0%
Tier B 25+ unit projects		16.0%	17.0%	17.5%	18.0%
Tier C 10-24 unit projects		17.6%	17.6%	17.6%	17.6%
Tier C 25+ unit projects		17.6%	18.6%	19.1%	19.6%
Fee or Off-site UMU					
Tier A 10-24 unit projects		23.0%	23.0%	23.0%	23.0%
Tier A 25+ unit projects		23.0%	28.0%	30.0%	30.0%
Tier B 10-24 unit projects		25.0%	25.0%	25.0%	25.0%
Tier B 25+ unit projects		25.0%	30.0%	30.0%	30.0%
Tier C 10-24 unit projects		27.0%	27.0%	27.0%	27.0%
Tier C 25+ unit projects		30.0%	30.0%	30.0%	30.0%
Land Dedication in UMU or Mission NCT					
Tier A 10-24 unit < 30K		35.0%	35.0%	35.0%	35.0%
Tier A 10-24 unit > 30K		30.0%	30.0%	30.0%	30.0%
Tier A 25+ unit < 30K		35.0%	40.0%	42.5%	45.0%
Tier A 25+ unit > 30K		30.0%	35.0%	37.5%	40.0%
Tier B 10-24 unit < 30K		40.0%	40.0%	40.0%	40.0%
Tier B 10-24 unit > 30K		35.0%	35.0%	35.0%	35.0%
Tier B 25+ unit < 30K		40.0%	45.0%	47.5%	50.0%
Tier B 25+ unit > 30K		35.0%	40.0%	42.5%	45.0%
Tier C 10-24 unit < 30K		45.0%	45.0%	45.0%	45.0%
Tier C 10-24 unit > 30K		40.0%	40.0%	40.0%	40.0%
Tier C 25+ unit < 30K		45.0%	50.0%	52.5%	55.0%
Tier C 25+ unit > 30K		40.0%	45.0%	47.5%	50.0%

CHART 2-A: Inclusionary Requirements for Rental projects with Complete EEA/PRJ accepted on or after 1/12/16

<i>Complete EEA/PRJ Accepted BEFORE: →</i>	1/1/18	1/1/19	1/1/20	1/1/21	1/1/22	1/1/23	1/1/24	1/1/25	1/1/26	1/1/27	1/1/28
On-site											
10-24 unit projects	12.0%	12.5%	13.0%	13.5%	14.0%	14.5%	15.0%	15.0%	15.0%	15.0%	15.0%
25+ unit projects	18.0%	19.0%	20.0%	20.5%	21.0%	21.5%	22.0%	22.5%	23.0%	23.5%	24.0%
Fee or Off-site											
10-24 unit projects	20.0%	20.0%	20.0%	20.0%	20.0%	20.0%	20.0%	20.0%	20.0%	20.0%	20.0%
25+ unit projects	30.0%	30.0%	30.0%	30.0%	30.0%	30.0%	30.0%	30.0%	30.0%	30.0%	30.0%

CHART 2-B: Requirements for Rental Projects in UMU Districts with Complete EEA/PRJ accepted on or after 1/12/16

Please note that certain projects in the SOMA Youth and Family SUD and Western SOMA SUD also rely upon UMU requirements.

<i>Complete EEA/PRJ Accepted BEFORE: →</i>	1/1/18	1/1/19	1/1/20	1/1/21	1/1/22	1/1/23	1/1/24	1/1/25	1/1/26	1/1/27	1/1/28
On-site UMU											
Tier A 10-24 unit projects	14.4%	14.4%	14.4%	14.4%	14.4%	14.5%	15.0%	15.0%	15.0%	15.0%	15.0%
Tier A 25+ unit projects	18.0%	19.0%	20.0%	20.5%	21.0%	21.5%	22.0%	22.5%	23.0%	23.5%	24.0%
Tier B 10-24 unit projects	16.0%	16.0%	16.0%	16.0%	16.0%	16.0%	16.0%	16.0%	16.0%	16.0%	16.0%
Tier B 25+ unit projects	18.0%	19.0%	20.0%	20.5%	21.0%	21.5%	22.0%	22.5%	23.0%	23.5%	24.0%
Tier C 10-24 unit projects	17.6%	17.6%	17.6%	17.6%	17.6%	17.6%	17.6%	17.6%	17.6%	17.6%	17.6%
Tier C 25+ unit projects	19.6%	19.6%	20.0%	20.5%	21.0%	21.5%	22.0%	22.5%	23.0%	23.5%	24.0%
Fee or Off-site UMU											
Tier A 10-24 unit projects	23.0%	23.0%	23.0%	23.0%	23.0%	23.0%	23.0%	23.0%	23.0%	23.0%	23.0%
Tier A 25+ unit projects	30.0%	30.0%	30.0%	30.0%	30.0%	30.0%	30.0%	30.0%	30.0%	30.0%	30.0%
Tier B 10-24 unit projects	25.0%	25.0%	25.0%	25.0%	25.0%	25.0%	25.0%	25.0%	25.0%	25.0%	25.0%
Tier B 25+ unit projects	30.0%	30.0%	30.0%	30.0%	30.0%	30.0%	30.0%	30.0%	30.0%	30.0%	30.0%
Tier C 10-24 unit projects	27.0%	27.0%	27.0%	27.0%	27.0%	27.0%	27.0%	27.0%	27.0%	27.0%	27.0%
Tier C 25+ unit projects	30.0%	30.0%	30.0%	30.0%	30.0%	30.0%	30.0%	30.0%	30.0%	30.0%	30.0%
Land Dedication in UMU or Mission NCT											
Tier A 10-24 unit < 30K	35.0%	35.0%	35.0%	35.0%	35.0%	35.0%	35.0%	35.0%	35.0%	35.0%	35.0%
Tier A 10-24 unit > 30K	30.0%	30.0%	30.0%	30.0%	30.0%	30.0%	30.0%	30.0%	30.0%	30.0%	30.0%
Tier A 25+ unit < 30K	35.0%	35.0%	35.0%	35.0%	35.0%	35.0%	35.0%	35.0%	35.0%	35.0%	35.0%
Tier A 25+ unit > 30K	30.0%	30.0%	30.0%	30.0%	30.0%	30.0%	30.0%	30.0%	30.0%	30.0%	30.0%
Tier B 10-24 unit < 30K	40.0%	40.0%	40.0%	40.0%	40.0%	40.0%	40.0%	40.0%	40.0%	40.0%	40.0%
Tier B 10-24 unit > 30K	35.0%	35.0%	35.0%	35.0%	35.0%	35.0%	35.0%	35.0%	35.0%	35.0%	35.0%
Tier B 25+ unit < 30K	40.0%	40.0%	40.0%	40.0%	40.0%	40.0%	40.0%	40.0%	40.0%	40.0%	40.0%
Tier B 25+ unit > 30K	35.0%	35.0%	35.0%	35.0%	35.0%	35.0%	35.0%	35.0%	35.0%	35.0%	35.0%
Tier C 10-24 unit < 30K	45.0%	45.0%	45.0%	45.0%	45.0%	45.0%	45.0%	45.0%	45.0%	45.0%	45.0%
Tier C 10-24 unit > 30K	40.0%	40.0%	40.0%	40.0%	40.0%	40.0%	40.0%	40.0%	40.0%	40.0%	40.0%
Tier C 25+ unit < 30K	45.0%	45.0%	45.0%	45.0%	45.0%	45.0%	45.0%	45.0%	45.0%	45.0%	45.0%
Tier C 25+ unit > 30K	40.0%	40.0%	40.0%	40.0%	40.0%	40.0%	40.0%	40.0%	40.0%	40.0%	40.0%

CHART 3-A: Inclusionary Requirements for Owner projects with Complete EEA/PRJ accepted on or after 1/12/16

<i>Complete EEA/PRJ Accepted BEFORE: →</i>	1/1/18	1/1/19	1/1/20	1/1/21	1/1/22	1/1/23	1/1/24	1/1/25	1/1/26	1/1/27	1/1/28
On-site											
10-24 unit projects	12.0%	12.5%	13.0%	13.5%	14.0%	14.5%	15.0%	15.0%	15.0%	15.0%	15.0%
25+ unit projects	20.0%	21.0%	22.0%	22.5%	23.0%	23.5%	24.0%	24.5%	25.0%	25.5%	26.0%
Fee or Off-site											
10-24 unit projects	20.0%	20.0%	20.0%	20.0%	20.0%	20.0%	20.0%	20.0%	20.0%	20.0%	20.0%
25+ unit projects	33.0%	33.0%	33.0%	33.0%	33.0%	33.0%	33.0%	33.0%	33.0%	33.0%	33.0%

CHART 3-B: Requirements for Owner Projects UMU Districts with Complete EEA/PRJ accepted on or after 1/12/16

Please note that certain projects in the SOMA Youth and Family SUD and Western SOMA SUD also rely upon UMU requirements.

<i>Complete EEA/PRJ Accepted BEFORE: →</i>	1/1/18	1/1/19	1/1/20	1/1/21	1/1/22	1/1/23	1/1/24	1/1/25	1/1/26	1/1/27	1/1/28
On-site UMU											
Tier A 10-24 unit projects	14.4%	14.4%	14.4%	14.4%	14.4%	14.4%	15.0%	15.0%	15.0%	15.0%	15.0%
Tier A 25+ unit projects	20.0%	21.0%	22.0%	22.5%	23.0%	23.5%	24.0%	24.5%	25.0%	25.5%	26.0%
Tier B 10-24 unit projects	16.0%	16.0%	16.0%	16.0%	16.0%	16.0%	16.0%	16.0%	16.0%	16.0%	16.0%
Tier B 25+ unit projects	20.0%	21.0%	22.0%	22.5%	23.0%	23.5%	24.0%	24.5%	25.0%	25.5%	26.0%
Tier C 10-24 unit projects	17.6%	17.6%	17.6%	17.6%	17.6%	17.6%	17.6%	17.6%	17.6%	17.6%	17.6%
Tier C 25+ unit projects	20.0%	21.0%	22.0%	22.5%	23.0%	23.5%	24.0%	24.5%	25.0%	25.5%	26.0%
Fee or Off-site UMU											
Tier A 10-24 unit projects	23.0%	23.0%	23.0%	23.0%	23.0%	23.0%	23.0%	23.0%	23.0%	23.0%	23.0%
Tier A 25+ unit projects	33.0%	33.0%	33.0%	33.0%	33.0%	33.0%	33.0%	33.0%	33.0%	33.0%	33.0%
Tier B 10-24 unit projects	25.0%	25.0%	25.0%	25.0%	25.0%	25.0%	25.0%	25.0%	25.0%	25.0%	25.0%
Tier B 25+ unit projects	33.0%	33.0%	33.0%	33.0%	33.0%	33.0%	33.0%	33.0%	33.0%	33.0%	33.0%
Tier C 10-24 unit projects	27.0%	27.0%	27.0%	27.0%	27.0%	27.0%	27.0%	27.0%	27.0%	27.0%	27.0%
Tier C 25+ unit projects	33.0%	33.0%	33.0%	33.0%	33.0%	33.0%	33.0%	33.0%	33.0%	33.0%	33.0%
Land Dedication in UMU or Mission NCT											
Tier A 10-24 unit < 30K	35.0%	35.0%	35.0%	35.0%	35.0%	35.0%	35.0%	35.0%	35.0%	35.0%	35.0%
Tier A 10-24 unit > 30K	30.0%	30.0%	30.0%	30.0%	30.0%	30.0%	30.0%	30.0%	30.0%	30.0%	30.0%
Tier A 25+ unit < 30K	35.0%	35.0%	35.0%	35.0%	35.0%	35.0%	35.0%	35.0%	35.0%	35.0%	35.0%
Tier A 25+ unit > 30K	30.0%	30.0%	30.0%	30.0%	30.0%	30.0%	30.0%	30.0%	30.0%	30.0%	30.0%
Tier B 10-24 unit < 30K	40.0%	40.0%	40.0%	40.0%	40.0%	40.0%	40.0%	40.0%	40.0%	40.0%	40.0%
Tier B 10-24 unit > 30K	35.0%	35.0%	35.0%	35.0%	35.0%	35.0%	35.0%	35.0%	35.0%	35.0%	35.0%
Tier B 25+ unit < 30K	40.0%	40.0%	40.0%	40.0%	40.0%	40.0%	40.0%	40.0%	40.0%	40.0%	40.0%
Tier B 25+ unit > 30K	35.0%	35.0%	35.0%	35.0%	35.0%	35.0%	35.0%	35.0%	35.0%	35.0%	35.0%
Tier C 10-24 unit < 30K	45.0%	45.0%	45.0%	45.0%	45.0%	45.0%	45.0%	45.0%	45.0%	45.0%	45.0%
Tier C 10-24 unit > 30K	40.0%	40.0%	40.0%	40.0%	40.0%	40.0%	40.0%	40.0%	40.0%	40.0%	40.0%
Tier C 25+ unit < 30K	45.0%	45.0%	45.0%	45.0%	45.0%	45.0%	45.0%	45.0%	45.0%	45.0%	45.0%
Tier C 25+ unit > 30K	40.0%	40.0%	40.0%	40.0%	40.0%	40.0%	40.0%	40.0%	40.0%	40.0%	40.0%

CHART 4-A: Inclusionary Requirements for Rental projects with Complete EEA/PRJ accepted on or after 1/12/16 located in the North of Market Residential Special Use District, the Mission Area Plan, or the SOMA Neighborhood Commercial Transit District.

Complete EEA/PRJ Accepted BEFORE: →	1/1/18	1/1/19	1/1/20	1/1/21	1/1/22	1/1/23	1/1/24	1/1/25	1/1/26	1/1/27	1/1/28
On-site											
10-24 unit projects	12.0%	12.5%	13.0%	13.5%	14.0%	14.5%	15.0%	15.0%	15.0%	15.0%	15.0%
25+ unit projects*	25.0%	25.0%	25.0%	25.0%	25.0%	25.0%	25.0%	25.0%	25.0%	25.0%	25.0%
Fee or Off-site											
10-24 unit projects	20.0%	20.0%	20.0%	20.0%	20.0%	20.0%	20.0%	20.0%	20.0%	20.0%	20.0%
25+ unit projects	30.0%	30.0%	30.0%	30.0%	30.0%	30.0%	30.0%	30.0%	30.0%	30.0%	30.0%

Complete EEA/PRJ Accepted BEFORE: →	1/1/18	1/1/19	1/1/20	1/1/21	1/1/22	1/1/23	1/1/24	1/1/25	1/1/26	1/1/27	1/1/28
On-Site: Rental Projects - North of Market Residential SUD; Mission Plan Area; SOMA NCT with 25+ units											
INCLUSIONARY RATE	25.0%	25.0%	25.0%	25.0%	25.0%	25.0%	25.0%	25.0%	25.0%	25.0%	25.0%
Low Income (55% AMI)	15.0%	15.0%	15.0%	15.0%	15.0%	15.0%	15.0%	15.0%	15.0%	15.0%	15.0%
Moderate Income (80% AMI)	5.0%	5.0%	5.0%	5.0%	5.0%	5.0%	5.0%	5.0%	5.0%	5.0%	5.0%
Middle Income (110% AMI)	5.0%	5.0%	5.0%	5.0%	5.0%	5.0%	5.0%	5.0%	5.0%	5.0%	5.0%

CHART 4-B: Inclusionary Requirements for Owner projects with Complete EEA/PRJ accepted on or after 1/12/16 located in the North of Market Residential Special Use District, the Mission Area Plan, or the SOMA Neighborhood Commercial Transit District.

Complete EEA/PRJ Accepted BEFORE: →	1/1/18	1/1/19	1/1/20	1/1/21	1/1/22	1/1/23	1/1/24	1/1/25	1/1/26	1/1/27	1/1/28
On-site											
10-24 unit projects	12.0%	12.5%	13.0%	13.5%	14.0%	14.5%	15.0%	15.0%	15.0%	15.0%	15.0%
25+ unit projects*	27.0%	27.0%	27.0%	27.0%	27.0%	27.0%	27.0%	27.0%	27.0%	27.0%	27.0%
Fee or Off-site											
10-24 unit projects	20.0%	20.0%	20.0%	20.0%	20.0%	20.0%	20.0%	20.0%	20.0%	20.0%	20.0%
25+ unit projects	33.0%	33.0%	33.0%	33.0%	33.0%	33.0%	33.0%	33.0%	33.0%	33.0%	33.0%

Complete EEA/PRJ Accepted BEFORE: →	1/1/18	1/1/19	1/1/20	1/1/21	1/1/22	1/1/23	1/1/24	1/1/25	1/1/26	1/1/27	1/1/28
On-Site: Ownership Projects - North of Market Residential SUD; Mission Plan Area; SOMA NCT with 25+ units											
INCLUSIONARY RATE	27.0%	27.0%	27.0%	27.0%	27.0%	27.0%	27.0%	27.0%	27.0%	27.0%	27.0%
Low Income (80% AMI)	15.0%	15.0%	15.0%	15.0%	15.0%	15.0%	15.0%	15.0%	15.0%	15.0%	15.0%
Moderate Income (105% AMI)	6.0%	6.0%	6.0%	6.0%	6.0%	6.0%	6.0%	6.0%	6.0%	6.0%	6.0%
Middle Income (130% AMI)	6.0%	6.0%	6.0%	6.0%	6.0%	6.0%	6.0%	6.0%	6.0%	6.0%	6.0%

CHART 5: Income Levels for Projects with a complete EEA/PRJ on or after January 12, 2016

Projects with complete EEA Application on or after January 12, 2016 are subject to the Inclusionary rates identified in Charts 2 and 3. For projects that propose on-site or off-site Inclusionary units, the Inclusionary Affordable Housing Program requires that inclusionary units be provided at three income tiers, which are split into three tiers. Annual increases to the inclusionary rate will be allocated to specific tiers, as shown below. Projects in the UMU Zoning District are not subject to the affordability levels below. Rental projects with 10-24 units shall provide all of the required Inclusionary units with an affordable rent at 55% Area Median Income (AMI), and ownership projects with 10-24 units shall provide all of the required Inclusionary units at sales price set at 80% AMI.

Complete EEA/PRJ Accepted BEFORE: →	1/1/18	1/1/19	1/1/20	1/1/21	1/1/22	1/1/23	1/1/24	1/1/25	1/1/26	1/1/27	1/1/28
On-Site: Rental Projects with 25+ units											
INCLUSIONARY RATE	18.0%	19.0%	20.0%	20.5%	21.0%	21.5%	22.0%	22.5%	23.0%	23.5%	24.0%
Low Income (55% AMI)	10.0%	11.0%	12.0%	12.0%	12.0%	12.0%	12.0%	12.0%	12.0%	12.0%	12.0%
Moderate Income (80% AMI)	4.0%	4.0%	4.0%	4.25%	4.5%	4.75%	5.0%	5.25%	5.5%	5.75%	6.0%
Middle Income (110% AMI)	4.0%	4.0%	4.0%	4.25%	4.5%	4.75%	5.0%	5.25%	5.5%	5.75%	6.0%

Complete EEA/PRJ Accepted BEFORE: →	1/1/18	1/1/19	1/1/20	1/1/21	1/1/22	1/1/23	1/1/24	1/1/25	1/1/26	1/1/27	1/1/28
On-Site: Ownership Projects with 25+ units											
INCLUSIONARY RATE	20.0%	21.0%	22.0%	22.5%	23.0%	23.5%	24.0%	24.5%	25.0%	25.5%	26.0%
Low Income (80% AMI)	10.0%	11.0%	12.0%	12.0%	12.0%	12.0%	12.0%	12.0%	12.0%	12.0%	12.0%
Moderate Income (105% AMI)	5.0%	5.0%	5.0%	5.25%	5.5%	5.75%	6.0%	6.25%	6.5%	6.75%	7.0%
Middle Income (130% AMI)	5.0%	5.0%	5.0%	5.25%	5.5%	5.75%	6.0%	6.25%	6.5%	6.75%	7.0%

Complete EEA/PRJ Accepted BEFORE: →	1/1/18	1/1/19	1/1/20	1/1/21	1/1/22	1/1/23	1/1/24	1/1/25	1/1/26	1/1/27	1/1/28
Off-Site: Rental Projects with 25+ units											
INCLUSIONARY RATE	30.0%	30.0%	30.0%	30.0%	30.0%	30.0%	30.0%	30.0%	30.0%	30.0%	30.0%
Low Income (55% AMI)	18.0%	18.0%	18.0%	18.0%	18.0%	18.0%	18.0%	18.0%	18.0%	18.0%	18.0%
Moderate Income (80% AMI)	6.0%	6.0%	6.0%	6.0%	6.0%	6.0%	6.0%	6.0%	6.0%	6.0%	6.0%
Middle Income (110% AMI)	6.0%	6.0%	6.0%	6.0%	6.0%	6.0%	6.0%	6.0%	6.0%	6.0%	6.0%

Complete EEA/PRJ Accepted BEFORE: →	1/1/18	1/1/19	1/1/20	1/1/21	1/1/22	1/1/23	1/1/24	1/1/25	1/1/26	1/1/27	1/1/28
Off-Site: Ownership Projects with 25+ units											
INCLUSIONARY RATE	33.0%	33.0%	33.0%	33.0%	33.0%	33.0%	33.0%	33.0%	33.0%	33.0%	33.0%
Low Income (80% AMI)	18.0%	18.0%	18.0%	18.0%	18.0%	18.0%	18.0%	18.0%	18.0%	18.0%	18.0%
Moderate Income (105% AMI)	8.0%	8.0%	8.0%	8.0%	8.0%	8.0%	8.0%	8.0%	8.0%	8.0%	8.0%
Middle Income (130% AMI)	7.0%	7.0%	7.0%	7.0%	7.0%	7.0%	7.0%	7.0%	7.0%	7.0%	7.0%

SUPPLEMENTAL INFORMATION FOR Anti-Discriminatory Housing Policy

1. Owner/Applicant Information

PROPERTY OWNER'S NAME: Turk Street LLC	
PROPERTY OWNER'S ADDRESS: 8 Dellbrook Avenue San Francisco, CA 94131	TELEPHONE: (415) 832-9171
	EMAIL: nickijudd @ hotmail.com

APPLICANT'S NAME: Same as Above <input checked="" type="checkbox"/>	
APPLICANT'S ADDRESS:	TELEPHONE: ()
	EMAIL:

CONTACT FOR PROJECT INFORMATION: Same as Above <input checked="" type="checkbox"/>	
ADDRESS:	TELEPHONE: ()
	EMAIL:

COMMUNITY LIAISON FOR PROJECT (PLEASE REPORT CHANGES TO THE ZONING ADMINISTRATOR): Same as Above <input checked="" type="checkbox"/>	
ADDRESS:	TELEPHONE: ()
	EMAIL:

2. Location and Project Description

STREET ADDRESS OF PROJECT: 468 Turk Street, San Francisco, CA		ZIP CODE: 94102
CROSS STREETS: Larkin & Hyde Streets		
ASSESSORS BLOCK/LOT: 0336 / 006	ZONING DISTRICT: RC - 4	HEIGHT/BULK DISTRICT: 80-T

PROJECT TYPE: (Please check all that apply)	EXISTING DWELLING UNITS:	PROPOSED DWELLING UNITS:	NET INCREASE:
<input checked="" type="checkbox"/> New Construction	0	101	101
<input checked="" type="checkbox"/> Demolition			
<input type="checkbox"/> Alteration			
<input type="checkbox"/> Other: _____			

Compliance with the Anti-Discriminatory Housing Policy

1. Does the applicant or sponsor, including the applicant or sponsor's parent company, subsidiary, or any other business or entity with an ownership share of at least 30% of the applicant's company, engage in the business of developing real estate, owning properties, or leasing or selling individual dwelling units in States or jurisdictions outside of California? YES NO

1a. If yes, in which States? _____

- 1b. If yes, does the applicant or sponsor, as defined above, have policies in individual States that prohibit discrimination based on sexual orientation and gender identity in the sale, lease, or financing of any dwelling units enforced on every property in the State or States where the applicant or sponsor has an ownership or financial interest? YES NO

- 1c. If yes, does the applicant or sponsor, as defined above, have a national policy that prohibits discrimination based on sexual orientation and gender identity in the sale, lease, or financing of any dwelling units enforced on every property in the United States where the applicant or sponsor has an ownership or financial interest in property? YES NO

If the answer to 1b and/or 1c is yes, please provide a copy of that policy or policies as part of the supplemental information packet to the Planning Department.

Human Rights Commission contact information
hrc.info@sfgov.org or (415)252-2500

Applicant's Affidavit

Under penalty of perjury the following declarations are made:

- a: The undersigned is the owner or authorized agent of the owner of this property.
- b: The information presented is true and correct to the best of my knowledge.
- c: Other information or applications may be required.

Signature:  _____

Date: **May 15, 2020** _____

Print name, and indicate whether owner, or authorized agent:

Nick Judd

Owner / Authorized Agent (circle one)

Owner / Managing Partner for Turk Street LLC

PLANNING DEPARTMENT USE ONLY

PLANNING DEPARTMENT VERIFICATION:

- Anti-Discriminatory Housing Policy Form is **Complete**
 Anti-Discriminatory Housing Policy Form is **Incomplete**

Notification of Incomplete Information made:

To: _____ Date: _____

BUILDING PERMIT NUMBER(S):

DATE FILED:

RECORD NUMBER:

DATE FILED:

2019-020740PRJ

11/04/2019

VERIFIED BY PLANNER:

Signature: Alexandra Kirby Date: 3/9/2021

Printed Name: Alexandra Kirby Phone: 628-652-7336

ROUTED TO HRC:

DATE:

Emailed to: _____



SUPPLEMENTAL INFORMATION PACKET FOR Anti-Discriminatory Housing Policy

Planning Department
1650 Mission Street
Suite 400
San Francisco, CA
94103-9425

T: 415.558.6378
F: 415.558.6409

Pursuant to Administrative Code Section 1.61, certain housing projects must complete and submit a completed Anti-Discriminatory Housing Policy form as part of any entitlement or building permit application that proposes an increase of ten (10) dwelling units or more.

Planning Department staff is available to advise you in the preparation of this application. Call (415)558-6377 for further information.

WHEN IS THE SUPPLEMENTAL INFORMATION FORM NECESSARY?

Administrative Code Section 1.61 requires the Planning Department to collect an application/form with information about an applicant's internal anti-discriminatory policies for projects proposing an increase of ten (10) dwelling units or more.

WHAT IF THE PROJECT SPONSOR OR PERMITTEE CHANGE PRIOR TO THE FIRST ISSUANCE OF CERTIFICATE OF OCCUPANCY?

If the permittee and/or sponsor should change, they shall notify the Planning Department and file a new supplemental information form with the updated information.

HOW IS THIS INFORMATION USED?

The Planning Department is not to review the responses other than to confirm that all questions have been answered. Upon confirmation, the information is routed to the Human Rights Commission.

For questions about the Human Rights Commission (HRC) and/or the Anti-Discriminatory Housing Policy, please call (415) 252-2500 or email hrc.info@sfgov.org.

All building permit applications and/or entitlements related to a project proposing 10 dwelling units or more will not be considered complete until all responses are provided.

WHAT PART OF THE POLICY IS BEING REVIEWED?

The Human Rights Commission will review the policy to verify whether it addresses discrimination based on sexual orientation and gender identity. The policy will be considered incomplete if it lacks such protections.

WILL THE ANSWERS TO THE QUESTIONS EFFECT THE REVIEW OF MY PROJECT?

The Planning Department's and Planning Commission's processing of and recommendations or determinations regarding an application shall be unaffected by the applicant's answers to the questions.

INSTRUCTIONS:

The attached supplemental information form is to be submitted as part of the required entitlement application and/or Building Permit Application. This application does not require an additional fee.

Answer all questions fully and type or print in ink. Attach additional pages if necessary.

Please see the primary entitlement application or Building Permit Application instructions for a list of necessary materials required.

THIS PAGE INTENTIONALLY LEFT BLANK.



**SAN FRANCISCO
PLANNING
DEPARTMENT**

FOR MORE INFORMATION:
Call or visit the San Francisco Planning Department

Central Reception
1650 Mission Street, Suite 400
San Francisco CA 94103-2479

TEL: **415.558.6378**
FAX: **415 558-6409**
WEB: **<http://www.sfplanning.org>**

Planning Information Center (PIC)
1660 Mission Street, First Floor
San Francisco CA 94103-2479

TEL: **415.558.6377**
*Planning staff are available by phone and at the PIC counter.
No appointment is necessary.*



SAN FRANCISCO
PLANNING
DEPARTMENT

AFFIDAVIT FOR FIRST SOURCE HIRING PROGRAM

Administrative Code

Chapter 83

1650 Mission Street, Suite 400 • San Francisco CA 94103-2479 • 415.558.6378 • <http://www.sfplanning.org>

Section 1: Project Information

PROJECT ADDRESS		BLOCK/LOT(S)	
468 Turk Street		0336/ 006	
BUILDING PERMIT APPLICATION NO.	CASE NO. (IF APPLICABLE)	MOTION NO. (IF APPLICABLE)	
	2019-020740 PRJ		
PROJECT SPONSOR	MAIN CONTACT	PHONE	
Turk Street LLC	Nick Judd	(415) 832-9171	
ADDRESS			
8 Dellbrook Avenue			
CITY, STATE, ZIP		EMAIL	
San Francisco, CA 94131		nickjudd @ hotmail.com	
ESTIMATED RESIDENTIAL UNITS	ESTIMATED SQ FT COMMERCIAL SPACE	ESTIMATED HEIGHT/FLOORS	ESTIMATED CONSTRUCTION COST
91	0	9 + basement	\$10.58 Million
ANTICIPATED START DATE			
2021 – 4th Quarter			

Section 2: First Source Hiring Program Verification

CHECK ALL BOXES APPLICABLE TO THIS PROJECT	
<input checked="" type="checkbox"/>	Project is wholly Residential
<input type="checkbox"/>	Project is wholly Commercial
<input checked="" type="checkbox"/>	Project is Mixed Use
<input checked="" type="checkbox"/>	A: The project consists of ten (10) or more residential units;
<input type="checkbox"/>	B: The project consists of 25,000 square feet or more gross commercial floor area.
<input type="checkbox"/>	C: Neither 1A nor 1B apply.
NOTES:	
<ul style="list-style-type: none"> If you checked C, this project is <u>NOT</u> subject to the First Source Hiring Program. Sign Section 4: Declaration of Sponsor of Project and submit to the Planning Department. If you checked A or B, your project <u>IS</u> subject to the First Source Hiring Program. Please complete the reverse of this document, sign, and submit to the Planning Department prior to any Planning Commission hearing. If principally permitted, Planning Department approval of the Site Permit is required for all projects subject to Administrative Code Chapter 83. For questions, please contact OEWD's CityBuild program at CityBuild@sfgov.org or (415) 701-4848. For more information about the First Source Hiring Program visit www.workforcedevelopmentsf.org If the project is subject to the First Source Hiring Program, you are required to execute a Memorandum of Understanding (MOU) with OEWD's CityBuild program prior to receiving construction permits from Department of Building Inspection. 	

Continued...

Section 3: First Source Hiring Program – Workforce Projection

Per Section 83.11 of Administrative Code Chapter 83, it is the developer’s responsibility to complete the following information to the best of their knowledge. **Unknown; to be determined once General Contractor is selected.**

Provide the estimated number of employees from each construction trade to be used on the project, indicating how many are entry and/or apprentice level as well as the anticipated wage for these positions.

Check the anticipated trade(s) and provide accompanying information (Select all that apply):

TRADE/CRAFT	ANTICIPATED JOURNEYMAN WAGE	# APPRENTICE POSITIONS	# TOTAL POSITIONS	TRADE/CRAFT	ANTICIPATED JOURNEYMAN WAGE	# APPRENTICE POSITIONS	# TOTAL POSITIONS
Abatement Laborer				Laborer			
Boilermaker				Operating Engineer			
Bricklayer				Painter			
Carpenter				Pile Driver			
Cement Mason				Plasterer			
Drywall/Latherer				Plumber and Pipefitter			
Electrician				Roofer/Water proofer			
Elevator Constructor				Sheet Metal Worker			
Floor Coverer				Sprinkler Fitter			
Glazier				Taper			
Heat & Frost Insulator				Tile Layer/ Finisher			
Ironworker				Other:			
			TOTAL:				TOTAL:

- | | | |
|--|--------------------------|--------------------------|
| 1. Will the anticipated employee compensation by trade be consistent with area Prevailing Wage? | YES | NO |
| | <input type="checkbox"/> | <input type="checkbox"/> |
| 2. Will the awarded contractor(s) participate in an apprenticeship program approved by the State of California’s Department of Industrial Relations? | <input type="checkbox"/> | <input type="checkbox"/> |
| 3. Will hiring and retention goals for apprentices be established? | <input type="checkbox"/> | <input type="checkbox"/> |
| 4. What is the estimated number of local residents to be hired? | | _____ |

Section 4: Declaration of Sponsor of Principal Project

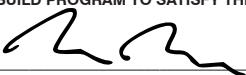
PRINT NAME AND TITLE OF AUTHORIZED REPRESENTATIVE	EMAIL	PHONE NUMBER
Nick Judd – Managing Partner Turk Street LLC	nickijudd @ hotmail.com	(415) 832–9171
I HEREBY DECLARE THAT THE INFORMATION PROVIDED HEREIN IS ACCURATE TO THE BEST OF MY KNOWLEDGE AND THAT I COORDINATED WITH OEWD’S CITYBUILD PROGRAM TO SATISFY THE REQUIREMENTS OF ADMINISTRATIVE CODE CHAPTER 83.		
		May 15, 2020
(SIGNATURE OF AUTHORIZED REPRESENTATIVE)		(DATE)

FOR PLANNING DEPARTMENT STAFF ONLY: PLEASE EMAIL AN ELECTRONIC COPY OF THE COMPLETED AFFIDAVIT FOR FIRST SOURCE HIRING PROGRAM TO OEWD’S CITYBUILD PROGRAM AT CITYBUILD@SFGOV.ORG

Cc: Office of Economic and Workforce Development, CityBuild
 Address: 1 South Van Ness 5th Floor San Francisco, CA 94103 Phone: 415-701-4848
 Website: www.workforcedevelopmentsf.org Email: CityBuild@sfgov.org

450 O'FARRELL

JOB SITE COPY

SITE PERMIT #2 - NOVEMBER 27, 2019



SFPUC - Please be advised
 Your plans and fixtures count indicate a larger water meter is required. Please apply for a water meter upgrade at SFPUC, New Service Installations, 525 Golden Gate Ave, 2nd Floor, San Francisco, CA 94102, Telephone: (415) 551-2900.

Capacity Charges
 \$1,200.00
 \$1,200.00
 \$1,200.00

SFPUC *[Signature]*

[Signature]
 Chu Liu, DBI
 MAY 01 2020

Certificates of occupancy shall not be issued before the completion of Lots merger.

APPROVED
 MAY 13 2020
[Signature]
 Dept. of Public Works

[Signature]
 Keith Harshman, SFPD
 MAY 02 2020

[Signature] (FOR DBI)
 Mark Walls, DBI
 APR 28 2020

SITE PERMIT REVISION
 DEC 12 2019
 THIS APPROVAL IS RESTRICTED TO THE SITE PERMIT ONLY - NO WORK MAY BE STARTED UNLESS CONSTRUCTION PLANS HAVE BEEN APPROVED



450 O'FARRELL SAN FRANCISCO, CA



To plant or remove trees/landscape in the sidewalk area obtain a separate permit from the Bureau of Urban Forestry. Please note that a 30-day posting is required to remove trees. Call (415) 554-6700 for information.

SFPW/BSM SIGN OFF ON JOB CARD REQUIRED PRIOR TO DBI FINAL CALL (415) 554-7149 TO SCHEDULE

By *[Signature]* 3/21/20
 THEO DEVINE DPW/BSM

[Signature] 5/14/20
 Approved Planner
 See 2013.1535CUA-02

2018-1029-4361 S/R1



From: [Dylan Casey](#)
To: [BOS Legislation, \(BOS\)](#)
Cc: [Victoria Fierce](#); [Gregory Magofna](#)
Subject: Comment on 469 Stevenson (Agenda Item 44) and 450 O'Farrell (Agenda Item 42)
Date: Tuesday, December 14, 2021 10:45:09 AM
Attachments: [SF 450 O'Farrell HAA Letter.pdf](#)
[SF 469 Stevenson HAA Letter.pdf](#)

This message is from outside the City email system. Do not open links or attachments from untrusted sources.

Dear Clerk of the Board,

I am submitting the two attached comment letters on behalf of California Renters Legal Advocacy and Education Fund, for agenda items 42 and 44 at this afternoon's meeting.

Sincerely,

Dylan Casey

Executive Director, California Renters Legal Advocacy and Education Fund
443-223-8231 | www.carlaef.org



California Renters Legal Advocacy and Education Fund

360 Grand Ave, #323
Oakland, CA 94612
hi@carlaef.org

December 14, 2021

San Francisco Board of Supervisors
City Hall, 1 Dr. Carlton B. Goodlett Place
San Francisco, CA 94102-4689

Re: 450-474 O'Farrell Street Denial

Dear San Francisco Board of Supervisors,

The California Renters Legal Advocacy and Education Fund (CaRLA) submits this letter to inform the San Francisco Board of Supervisors that they have an obligation to abide by all relevant state housing laws when evaluating the 450-474 O'Farrell Street development. The Housing Accountability Act requires approval of zoning and general plan compliant projects, such as this one, unless the city finds that the project would cause an impact on health and safety that is unavoidable and unmitigatable. These findings must be supported by a preponderance of evidence on the record, and be based on objective, written health and safety standards.

The proposed findings set forth in the motion under consideration fail to identify any standards with which this development fails to comply, and show no evidence of any health and safety impacts created by the development. Instead, the findings focus on the proposed group housing with limited kitchen facilities. The proposed resolution finds that there is a "glut" of smaller units in the neighborhood, and a greater need for larger units to house low-income families. This is not an objective standard, nor a health and safety finding.

There is undoubtedly a need for larger affordable units in San Francisco, but there is clearly a need for all sizes of housing at all affordability levels. Not all housing developments need to serve every population, and this particular one would not only provide flexible, more affordable housing, it would also provide 48 income-restricted homes as well. If the Board views the need for larger units to be so great that developments with smaller units should not be built, the place to enact this policy is through an ordinance to establish development standards that would require larger units. Reversing an approval of a project that has spent years in the permitting process does nothing for families in San Francisco.

Further, if this Board were truly concerned about the need for larger units in the area, it would not also be denying a separate project with 154 larger homes at this meeting. The 469 Stevenson Street development is less than a half-mile away from this project, yet the desperate need for larger affordable homes in the area has not deterred this Board from also denying that development. If San Francisco has any

hope of addressing its housing shortage, it needs both of these projects, and many more after that. It also needs the same type of high density housing in the majority of the city where this city continues to ban it. Instead, the Board is making up subjective reasons to unlawfully deny high-density housing in the small area of the city where it supposedly allows for it.

As you are well aware, California remains in the throes of a statewide crisis-level housing shortage. New housing such as this is a public benefit. It will bring increased tax revenue, new customers to local businesses, decarbonization in the face of the climate crisis, but most importantly, it will reduce the displacement of existing residents into homelessness or carbon-heavy car commutes. The laws cited in this letter are designed to allow and require cities to approve of new homes over the objection of a small minority of neighbors. Research indicates that the anti-housing voices frequent in public hearings are disproportionately white, higher-income, and homeowners.¹ These voices do not represent the best interests of San Francisco or the broader community. Approving developments like this one over these vocal objections is a step towards racial, economic, environmental, and social justice. We urge San Francisco to deny this appeal, and approve of this project because it is the right decision for the City and is required by state law.

CaRLA is a 501(c)3 non-profit corporation whose mission includes advocating for increased access to housing for Californians at all income levels, including low-income households. While no one project will solve the regional housing crisis, the proposed development is the kind of housing San Francisco needs to mitigate displacement, provide shelter for its growing population, and arrest unsustainable housing price appreciation. You may learn more about CaRLA at www.carlaef.org.

Sincerely,



Dylan Casey
Executive Director
California Renters Legal Advocacy and Education Fund

¹ Einstein, Palmer, and Glick, *Who Participates in Local Government? Evidence from Meeting Minutes*, Perspectives on Politics, Volume 17, Issue 1, March 2019
https://www.dropbox.com/s/k4kzph3ynal3xai/ZoningParticipation_Perspectives_Final.pdf?dl=0



California Renters Legal Advocacy and Education Fund

360 Grand Ave, #323
Oakland, CA 94612
hi@carlaef.org

December 14, 2021

San Francisco Board of Supervisors
City Hall, 1 Dr. Carlton B. Goodlett Place
San Francisco, CA 94102-4689

Re: 469 Stevenson Street Appeal of Environmental Review

Dear San Francisco Board of Supervisors,

The California Renters Legal Advocacy and Education Fund (CaRLA) submits this letter to inform the San Francisco Board of Supervisors that they have an obligation to abide by all relevant state housing laws when evaluating the 469 Stevenson Street development. The Housing Accountability Act requires approval of zoning and general plan compliant projects, such as this one, unless the city finds that the project would cause an impact on health and safety that is unavoidable and unmitigatable. These findings must be supported by a preponderance of evidence on the record, and be based on objective, written health and safety standards.

The proposed findings set forth in the motion under consideration fail to identify any objective standards with which this development fails to comply, and show no evidence of any health and safety impacts created by the development. Instead, the findings take issue with the analysis of environmental impacts (EIR). Specifically, the proposed resolution raises concerns with the EIR's analysis of residential displacement, geotechnical impacts, and impacts on surrounding historic resources. None of these concerns are legitimate reasons to indefinitely delay this project, and deny hundreds of families much needed homes.

First, concerns raised about the geotechnical impacts of the project are unfounded and premature. Under the city's owner standards, review of the soundness and adequacy of a building foundation takes place after entitlement approval, during the city's ministerial consideration of building permits. Furthermore, these concerns seem to be pure speculation, since the record of the project contains no evidence of seismic safety concerns. The California Supreme Court has ruled that seismic dangers to new buildings are not impacts under CEQA, and are therefore beyond the scope of the EIR for this project.¹ Any concerns relating to seismic safety should be addressed by the city's building permit process, not used as a pretext for indefinite delay.

Second, the presence of a newer building next to some older buildings is not an "impact" on historic resources. If this were the case, no building would be built in any

¹ California Building Industry Assn. v. Bay Area Air Quality Management Dist. (2015) 62 Cal.4th 369.

city without impacting historic resources. The concerns raised by the proposed resolution and during the previous hearing fail to identify any specific impact on historic resources in the surrounding area, and offer no evidence of these impacts other than the presence and scale of the proposed building. Again, this is not a legitimate concern with the existing EIR analysis.

Lastly, the findings point to potential displacement of existing residents that would somehow result from the “large number of market-rate units” in the development. Other than conclusory statements from some commenters at the previous hearing on this project, there is again no evidence of this impact. Nearly every study on the issue concludes that the development of market-rate units reduces surrounding residential rents, thereby reducing displacement pressures.² Furthermore, the Board would be completely ignoring the 73 onsite affordable units and affordable housing fees generated by the development. These homes represent hundreds of low income families that would have stable housing and not be at risk of displacement if the development is approved. There can be little doubt that the development proposed here would do far more to prevent displacement than cause it. The fact that this Board is willing to delay this type of development indefinitely for little or no reason shows why San Francisco continues to push out its lower income residents. The policies and processes maintained by this Board are the main drivers of displacement of San Franciscan families. Until San Francisco is able to approve and build enough housing to keep pace with its job growth, this displacement will continue.

The Board today is considering requesting additional environmental analysis, but fails to show how the existing analysis is inadequate. Voting in favor of this resolution today will likely not shed any light on the supposed impacts identified, instead it will lead to months or years of delay, and most likely the failure of this project to ever be developed. Voting in favor of this resolution will effectively deny hundreds of families new homes in San Francisco.

As you are well aware, California remains in the throes of a statewide crisis-level housing shortage. New housing such as this is a public benefit. It will bring increased tax revenue, new customers to local businesses, decarbonization in the face of the climate crisis, but most importantly, it will reduce the displacement of existing residents into homelessness or carbon-heavy car commutes. The laws cited in this letter are designed to allow and require cities to approve of new homes over the objection of a small minority of neighbors. Research indicates that the anti-housing voices frequent in public hearings are disproportionately white, higher-income, and homeowners.³ These voices do not represent the best interests of San Francisco or the broader community. Approving developments like this one over these vocal objections

² https://research.upjohn.org/cgi/viewcontent.cgi?article=1334&context=up_workingpapers

³ Einstein, Palmer, and Glick, *Who Participates in Local Government? Evidence from Meeting Minutes*, Perspectives on Politics, Volume 17, Issue 1, March 2019

https://www.dropbox.com/s/k4kzph3ynal3xai/ZoningParticipation_Perspectives_Final.pdf?dl=0

is a step towards racial, economic, environmental, and social justice. We urge San Francisco to deny this appeal, and approve of this project because it is the right decision for the City and is required by state law.

CaRLA is a 501(c)3 non-profit corporation whose mission includes advocating for increased access to housing for Californians at all income levels, including low-income households. While no one project will solve the regional housing crisis, the proposed development is the kind of housing San Francisco needs to mitigate displacement, provide shelter for its growing population, and arrest unsustainable housing price appreciation. You may learn more about CaRLA at www.carlaef.org.

Sincerely,

A handwritten signature in black ink, appearing to read 'Dylan Casey', with a long horizontal line extending to the right.

Dylan Casey
Executive Director
California Renters Legal Advocacy and Education Fund