

File No. 101214

Committee Item No. 2

Board Item No. _____

COMMITTEE/BOARD OF SUPERVISORS

AGENDA PACKET CONTENTS LIST

Committee: Budget and Finance Committee

Date: October 20, 2010

Board of Supervisors Meeting

Date _____

Cmte Board

- | | | |
|-------------------------------------|--------------------------|--|
| <input type="checkbox"/> | <input type="checkbox"/> | Motion |
| <input checked="" type="checkbox"/> | <input type="checkbox"/> | Resolution |
| <input type="checkbox"/> | <input type="checkbox"/> | Ordinance |
| <input type="checkbox"/> | <input type="checkbox"/> | Legislative Digest |
| <input checked="" type="checkbox"/> | <input type="checkbox"/> | Budget Analyst Report |
| <input type="checkbox"/> | <input type="checkbox"/> | Legislative Analyst Report |
| <input type="checkbox"/> | <input type="checkbox"/> | Ethics Form 126 |
| <input type="checkbox"/> | <input type="checkbox"/> | Introduction Form (for hearings) |
| <input checked="" type="checkbox"/> | <input type="checkbox"/> | Department/Agency Cover Letter and/or Report |
| <input type="checkbox"/> | <input type="checkbox"/> | MOU |
| <input type="checkbox"/> | <input type="checkbox"/> | Grant Information Form |
| <input type="checkbox"/> | <input type="checkbox"/> | Grant Budget |
| <input type="checkbox"/> | <input type="checkbox"/> | Subcontract Budget |
| <input checked="" type="checkbox"/> | <input type="checkbox"/> | Contract/Agreement |
| <input type="checkbox"/> | <input type="checkbox"/> | Award Letter |
| <input type="checkbox"/> | <input type="checkbox"/> | Application |
| <input type="checkbox"/> | <input type="checkbox"/> | Public Correspondence |

OTHER

(Use back side if additional space is needed)

| | | |
|--------------------------|--------------------------|-------|
| <input type="checkbox"/> | <input type="checkbox"/> | _____ |
| <input type="checkbox"/> | <input type="checkbox"/> | _____ |
| <input type="checkbox"/> | <input type="checkbox"/> | _____ |
| <input type="checkbox"/> | <input type="checkbox"/> | _____ |
| <input type="checkbox"/> | <input type="checkbox"/> | _____ |

Completed by: Victor Young

Date: October 15, 2010

Completed by: Victor Young

Date: _____

An asterisked item represents the cover sheet to a document that exceeds 25 pages. The complete document is in the file.

1 [Airline/Airport Lease and Use Agreement Modifications and Lease and Operating Agreement
2 Modifications]

3
4 **Resolution approving modifications to the terms of two Airline/Airport Lease and Use**
5 **Agreements between the City and County of San Francisco and Alaska Airlines, Inc. and**
6 **Continental Airlines, Inc. to allow such Airlines to modify the rental of Terminal Space.**

7
8 WHEREAS, Alaska Airlines, Inc. and Continental Airlines, Inc. conduct flight operations at San
9 Francisco International Airport pursuant to Airline/Airport Lease and Use Agreements which terminate
10 on June 30, 2011, including: Alaska Airlines, Inc. – L82-0314; Continental Airlines-L82-0316,
11 (collectively, the "Lease and Use Airlines") and

12 WHEREAS, the Airport Commission of the City and County of San Francisco (the "City"), the
13 Lease and Use Airlines (collectively, the "Airlines") have negotiated a new Lease and Use Agreement
14 to take effect July 1, 2011 (the "Lease") for a term of ten (10) years; and

15 WHEREAS, conditioned upon execution of the Lease, the City and Airlines now desire to
16 amend the terms of the Lease and Use Agreements to reflect a reduction of rental of terminal space
17 for Fiscal Year 2010/2011 (collectively, the "Modifications"), the last year of said Agreements, as
18 described on Attachment A hereto; and

19 WHEREAS, the City also desires to authorize the Airport Director to enter into non-material
20 modifications to the Agreements, including changes to the demised premises of not-to-exceed ten
21 percent (10%) of the leased square footage, that the City, in consultation with the City Attorney,
22 determines are in the best interests of the Commission and necessary to effectuate the purposes of
23 the Agreements and are in compliance with all applicable laws, including the City's Charter; and

24 WHEREAS, the Commission approved the following Modifications to the respective Lease and
25 Use Agreements on August 17, 2010, by adoption of the Resolutions as follows: Alaska Airlines, Inc.

1 – L82-00314, Modification No. 7 by Resolution No. 10-0280; Continental Airlines, Inc. – L82-0316,
 2 Modification No. 5 by Resolution No. 10-0281; and therefore be it

3 RESOLVED, that this Board of Supervisors approves Modifications to the Lease and Use
 4 Agreements with Alaska Airlines, Inc. – L82-0314, Modification No. 7 by Resolution No. 10-0280;
 5 Continental Airlines, Inc. – L82-0316, Modification No. 5 by Resolution No. 10-0281; subject to Human
 6 Rights Commission's determination that said Airlines are in compliance with or exempt from the
 7 requirements of Chapter 12B of the City's Administrative Code; and, be it further

8 RESOLVED, that this Board of Supervisors authorizes the Airport Director to enter into non-
 9 material modifications to the Agreements, including changes to the demised premises of not-to-exceed
 10 ten percent (10%) of the leased square footage, that the Commission, in consultation with the City
 11 Attorney, determines are in the best interests of the Commission and necessary to effectuate the
 12 purposes of the Agreements and are in compliance with all applicable laws, including the City's
 13 Charter.

14 **Airline/Airport Lease & Use Agreement Modifications**

15 **Table 1 - Exclusive Use Space (in square feet)**

| | Airline | Lease # | Mod. # | Changes in Categories of Rent | | | | |
|---|----------------------|------------|--------|-------------------------------|--------|---------|--------|-------|
| | | | | Cat I | Cat II | Cat III | Cat IV | Cat V |
| 1 | Alaska Airlines | L82 - 0314 | 7 | 4,776 | 5,660 | 878 | 4,905 | - |
| 2 | Continental Airlines | L82 - 0316 | 5 | 8,675 | 12,500 | 11,139 | 7,543 | 4,949 |

19 **Table 2 - Joint Use Space (in square feet)**

| Joint Use Space | Categories of Rent | | | | |
|-------------------------------|--------------------|---------|---------|---------|-------|
| | Cat I | Cat II | Cat III | Cat IV | Cat V |
| International Terminal | | | | | |
| Total = 631,987 square feet | 138,367 | 214,307 | 12,025 | 265,400 | 1,888 |
| Terminal 1 | | | | | |
| Total = 1,007 square feet | - | 216 | - | 791 | - |

| | |
|---|--|
| Items 1 and 2 Files 10-1213 and 10-1214 | Department(s): San Francisco International Airport |
| EXECUTIVE SUMMARY | |
| Legislative Objective | |
| <ul style="list-style-type: none"> • <u>File 10-1213</u>: Resolution approving six new leases for a ten-year period from July 1, 2011 to June 30, 2021, between the San Francisco International Airport (Airport) and six airlines, including: (1) Alaska Airlines, Inc., (2) Continental Airlines, Inc., (3) US Airways, Inc., (4) Kalitta Air, LLC, (5) Nippon Cargo Airlines Company, Inc., and (6) Southern Air, Inc. • <u>File 10-1214</u>: Resolution approving modifications to two existing leases which will expire on June 30, 2011, between the Airport and Alaska Airlines, Inc. and Continental Airlines, Inc. | |
| Key Points | |
| <ul style="list-style-type: none"> • The rate and fee schedule, which is used to calculate the total rent paid by each airline, is determined by the Airport's "breakeven policy," or the residual rate setting methodology, which places the financial risk of balancing the Airport's budget on the airlines instead of the Airport, by allowing for automatic rent increases to the airlines to eliminate any Airport budgetary shortfalls. • The proposed resolution (File No. 1213) would approve the following six significant changes: (1) require airlines to submit all required landing fee payments 30 days earlier than they are due under the existing leases, (2) reduce security deposits required for four of the six airlines, (3) allow the airlines to request a one-time space reduction, on July 1, 2016, (4) consider the new leases for terminal space in default if an airline defaults on any other lease for non-terminal Airport space, (5) increase the insurance requirements, and (6) increase environmental protections. • The proposed resolution approving six new airline leases (File 10-1213) contain the same terms as leases for 25 airlines at the Airport, which were previously approved by the Board of Supervisors in May 2010 (File 10-351). | |
| Fiscal Impacts | |
| <ul style="list-style-type: none"> • Under the terms of the proposed six new leases (File 10-1213), the Airport anticipates receiving \$355,390,000 of lease revenues from the six airlines over the ten-year term. The proposed modifications to two existing leases (File 10-1214) would reduce the overall space leased to these two airlines by 37,391 square feet, or 5.1 percent. Together, these two resolutions would result in \$907,365 of reduced rent payable (see pages 7 and 8) to the Airport, which would be fully offset by increased rates to all airlines through the Airport's breakeven policy. | |
| Recommendations | |
| <ul style="list-style-type: none"> • Approve the proposed resolutions. | |

MANDATE STATEMENT / BACKGROUND**Mandate Statement**

Section 2A.173 of the City's Administrative Code authorizes the Airport to negotiate and execute leases of Airport lands and space in Airport buildings without undergoing a competitive bid process, as long as the original term of the lease does not exceed 50 years.

City Charter Section 9.118 (a) requires the Board of Supervisors approve any contract which would result in revenues to the City in excess of \$1,000,000.

Residual Rate Setting Methodology

Under the proposed leases, the Airport uses a "breakeven policy" known as the residual rate setting methodology to determine the rental rates, landing fees, and related fees used to calculate the total rent to be paid by each airline for use of Airport terminal space. The rental rates, landing fees, and related fees include (a) the cost per square foot charged to an airline for that airline's exclusive use of Airport space, (b) fees for use of space which is shared by multiple airlines, and (c) various non-space related fees, such as landing fees and aircraft parking fees. Those rental rates, landing fees, and related fees are then used to calculate the total rent payable by each airline to the Airport, such that while the total rent payable by each airline may differ due to (a) the amount of space leased, (b) the type of space leased, and (c) passenger and aircraft traffic, no airline has preferable lease terms over another airline.

The residual rate setting methodology is a formula which sets the schedule of all rental rates, landing fees, and related fees to a level which ensures that Airport revenues received from the airlines, plus the non-airline revenues received by the Airport, are equal to the Airport's total costs, including debt service and operating expenditures. According to this methodology, prior to the beginning of each fiscal year, the Airport first determines the total airline rent revenues needed to balance the Airport's budget in the upcoming year, after considering all other non-airline revenue sources (such as concession revenues and parking revenues) and carrying forward any projected budget shortfall or surplus from the current fiscal year. The amount needed to balance the Airport's budget then becomes the basis for calculating, by a formula specified in the lease, the rental rates, landing fees, and related fees charged to airlines in the upcoming year, such that the total revenues paid to the Airport by all airlines in the upcoming year is sufficient to balance the Airport's budget. At the end of the fiscal year, any budget shortfall or surplus is carried forward into the following fiscal year and is used in the calculation of the new rental rates, landing fees, and related fees charged to the airlines.

Existing Leases

According to Mr. Gary Franzella, Associate Deputy Airport Director, there are currently 60 airlines that have active operating leases or permits with the Airport, which allow each airline to conduct domestic and international flight operations at the Airport. Airlines without leases, but have permits, are non-signatory airlines, which according to Mr. Franzella, operate at the Airport under Airline Operating Permits and Terminal Space and Use Permits on a month-to-

month basis and, currently pay the same rental rates, landing fees, and related fees as airlines with leases (signatory airlines), as calculated by the residual rate setting methodology. Mr. Franzella notes that the main difference is that signatory airlines are included in the Airport's capital project approval process while non-signatory airlines are not. Mr. Franzella noted that these non-signatory airlines are not required to enter into leases with the Airport because, pursuant to Federal law, the Airport cannot prohibit airlines from operating at the Airport. Mr. Franzella stated that non-signatory airlines generally have not entered into leases with the Airport because, despite being offered leases by the Airport, there is currently no financial incentive to enter into a lease.

There are currently 24 airlines which have existing leases with the Airport. All current leases will expire on June 30, 2011. These leases were entered into either in 1981 or 1999, depending on when the airline decided to obtain a lease at the Airport. The airline leases entered into in 1999 are essentially an update to the leases entered into in 1981, with several provisions added to comply with the City's regulations that were approved between 1981 and 1999. The leases entered into in 1999 were only offered to international airlines because the International Terminal at the Airport became operational in 2000. The 24 airlines with existing leases each pay rent based on the same rental rates, landing fees, and related fees, all of which are established by the Airport each fiscal year. The total amount paid by each airline differs only due to the (a) square footage of the area occupied, (b) type of space occupied, (c) maximum landing weight of each aircraft landed, and (d) number of passengers. As such, no airline has preferable lease terms to any other airline.

Because all current leases will expire on June 30, 2011, the Airport has undertaken efforts to have as many airlines maintain or obtain signatory status by signing a 2011 Lease and Use Agreement, which would be effective from July 1, 2011 to June 30, 2021. As an incentive to becoming a signatory airline or maintaining signatory status, the Airport also offered participating airlines the opportunity to right-size their leased space in their current leases which expire June 30, 2011. In May 2010, the Board of Supervisors approved new leases with 25 airlines and 19 airlines took advantage of the right-sizing opportunity and reduced their leased space (File 10-351).

The proposed resolution (File 10-1213) would approve six new airline leases with (1) Alaska Airlines, Inc., (2) Continental Airlines, Inc., (3) US Airways, Inc., (4) Kalitta Air, LLC, (5) Nippon Cargo Airlines Company, Inc., and (6) Southern Air, Inc. Currently, Alaska Airlines and Continental Airlines have existing leases with the Airport which were entered into in 1981, Kalitta Air, Nippon Cargo Airlines, Southern Air, and US Airways have Airline Operating Permits and are non-signatory airlines. US Airways currently has a month-to-month permit and was given the opportunity to right-size its permitted spaces if it agreed to the 2011 Lease and Use Agreement in February 2010 and became a signatory airline.

DETAILS OF PROPOSED LEGISLATION

The proposed resolution (File 10-1213) would approve six new leases for a ten-year period between July 1, 2011 and June 30, 2021, between the San Francisco International Airport

(Airport) and six airlines to conduct domestic and international flight operations at the Airport. The six new leases are with the following airlines: (1) Alaska Airlines, Inc., (2) Continental Airlines, Inc., (3) US Airways, Inc., (4) Kalitta Air, LLC, (5) Nippon Cargo Airlines Company, Inc., and (6) Southern Air, Inc. Three of the proposed new leases (Alaska Airlines, Continental Airlines, and US Airways) would provide both landing rights and terminal space. The remaining three proposed new leases (Kalitta Air, Nippon Cargo Airlines, and Southern Air) are cargo-only airlines, which would only provide landing rights.¹

The proposed resolution (File 10-1214) would approve modifications to two existing leases between the Airport and Continental Airlines and Alaska Airlines, which will expire on June 30, 2011. These two airlines will have new leases under File 10-1213.

Six New Airport Leases (File 10-1213)

The proposed resolution (File 10-1213) would approve six new leases to provide terms under which these six airlines would use terminal space and/or have landing rights at the Airport. Each of the proposed six new leases is for a ten-year term, from July 1, 2011 through June 30, 2021. Under these new leases, each airline would pay the Airport revenues based on the rental rates, landing fees, and related fees calculated under the same residual rate setting methodology included in the existing leases. The only differences between the individual new leases would be (a) the name of each airline, and (b) the amount of space allocated to each airline. Because these leases function identically, they are discussed in combination as the “new leases,” rather than in six separate descriptions.

In addition to continuing the residual rate setting methodology (breakeven policy), the proposed new leases would also continue to require that the rental rates, landing fees, and related fees be sufficient to guarantee that the Airport’s Annual Service Payment to the City’s General Fund will not be less than \$5,000,000. The Annual Service Payment made by the Airport to the City is equal to the greater of (a) 15 percent of concession revenues², or (b) \$5,000,000. In the event that 15 percent of concession revenues is less than \$5,000,000, the Airport pays the City’s General Fund \$5,000,000, and the Airport recaptures the difference between the \$5,000,000 and 15 percent of concession revenues the following fiscal year through increased rental rates, landing fees, and related fees charged to the airlines as calculated by the residual rate setting methodology. Notably, the Airport’s 15 percent of concession revenue has exceeded \$5,000,000 every year since 1982. In FY 2010-2011, the Annual Service Payment to the City’s General Fund was budgeted at \$27,371,000.

There are six material differences between the existing leases and the proposed new leases that would impact Airline lessees as follows:

1. Landing Fees To Be Paid 30 Days Earlier

¹ The leases for the cargo-only airlines involve only landing rights and not terminal space. Cargo-only airlines have a separate type of lease that allows them to lease warehouses, office space, ground service equipment maintenance building, etc. The subject leases allow the cargo-only airlines to operate (land and take-off) at the Airport.

² Concession revenues are defined in the lease as those revenues paid to the Airport by non-airline entities such as newsstands, restaurants, bars, advertisers, and ground transportation operators.

Under the terms of the proposed leases, all six airlines would be required to submit all required landing fees to the Airport 30 days earlier than they are due under the terms of the existing leases. Currently, each airline must submit the number of monthly landings to the Airport by the 10th of the following month. Invoices for the landing fees are then processed and sent to each airline with a 30 day payment deadline. The new provision would require immediate payment of the invoices sent to the airlines. According to Mr. Franzella, this new provision benefits the Airport by reducing the amount of outstanding landing fees at any given time, thus reducing the Airport's risk of financial loss in the event that an airline files for bankruptcy.

2. Security Deposit Requirement to Be Decreased

The proposed new leases would require all six airlines to submit security deposits equal to two months of rent. Previously, leases that were executed in 1981 (Alaska Airlines and Continental Airlines) required airlines to provide the Airport with security deposits equal to two months of rent, and airlines with operating permits (Kalitta Air, Nippon Cargo Airlines, Southern Air, and US Airways) required airlines to provide the Airport with security deposits equal to six months of rent. The proposed new requirement is comparable to the 1981 executed leases but represents a reduction of four months in the required security deposit when compared to the operating permit requirements.

According to Mr. Franzella, the security deposits are intended to reimburse the Airport for losses which might occur in the event an airline is unable to pay rent or otherwise cause financial harm to the Airport. Mr. Franzella noted that a reduction in the security deposits does not increase the overall risk of financial loss to the Airport because, under the residual rate setting methodology, any budgetary shortfalls resulting from an airline's inability to pay rent would result in increases to the rental rates, landing fees, and related fees sufficient to offset such shortfalls.

3. Airlines to Have a One-Time Option to Reduce Exclusive-Use Space

Under the existing leases, airlines cannot reduce the amount of exclusive-use³ space in their lease. According to Mr. Franzella, this has resulted in underutilized space which was leased by airlines which have since reduced their flight operations and therefore their need for space at the Airport. The proposed leases would allow airlines to reduce the amount of leased exclusive-use space only one time, by up to 20 percent, on July 1, 2016. In the proposed resolution (File 10-1213), the three cargo-only airlines (Kalitta Air, Nippon Cargo Airlines, and Southern Air) would not be eligible for this one-time option because these cargo-only airlines would not be leasing any terminal space.

4. Airport to Have Additional Protections In The Event Of an Airline Lease Default

In addition to leases for airlines' use of terminal space, most airlines have separate leases for space on Airport land that is outside the terminal, such as hangar space, flight kitchens, and cargo buildings. For leases which were executed in 1981 for terminal space (Alaska Airlines and Continental Airlines), any default by an airline on its lease for non-terminal space has no effect

³ Exclusive-use space is space that is leased to a single airline and charged on a per square foot basis. Offices, clubs, lounges, ticket counters, and baggage handling space in domestic terminals comprise exclusive-use space.

on the lease for terminal space. Under the proposed leases for terminal space, if an airline defaults under any of its other leases for non-terminal space with the Airport, it would trigger default of the proposed lease for terminal space between that airline and the Airport. According to Mr. Franzella, this provides additional leverage to the Airport over airlines to enforce the terms of their other leases, and prevents an airline in bankruptcy from selectively keeping only those leases that the airline wishes to maintain.

5. Airline Insurance Requirements to Increase

Under the terms of the existing leases, all airlines are required to have \$25,000,000 in general liability insurance. Under the terms of the proposed leases, the six airlines would be required to maintain higher amounts and more specific types of insurance, including the following:

- (a) \$500,000,000 in aircraft liability insurance which provides coverage to both the airline and the Airport in the event of injury or property damage which results from airline activity, excluding injury or damage which occurs during acts of war,
- (b) \$100,000,000 in war and named perils insurance, which provides coverage for injury or property damage from airline activity which occur during war and other related events (or "named perils") and excluded from aircraft liability insurance discussed above,
- (c) \$2,000,000 in worker's compensation and employer's liability insurance, which is required by the State of California, with such insurance providing coverage to the airline for injuries sustained by employees,
- (d) \$2,000,000 in commercial auto insurance, which is also required by the State of California, with such insurance providing liability coverage for injuries and damage which occur resulting from the operation of vehicles at the Airport, and
- (e) property insurance in the amount of any improvements constructed by the airlines, which insures the airline against property damage which occurs from fire, flood, or other similar causes, except earthquakes.

According to Mr. Franzella, although these new insurance requirements are not directly comparable to the insurance requirements under the existing leases, the new requirements (a) better address the specific risks of concern to the Airport, and (b) reflect changes in the insurance industry which have occurred since the existing leases were written in 1981 and 1999. Mr. Franzella added that any damages which might occur which are not covered by the required insurance provisions would result in higher rental rates, landing fees, and related fees charged to the airlines under the Airport's residual rate setting methodology.

6. Environmental Protections to Increase

Leases which were executed in 1981 do not address the handling of hazardous materials, and leases executed in 1999 had limited restrictions on airline's handling of hazardous materials. The proposed six new leases would provide for a number of increased environmental protections, including (a) expanding the definition of "environmental law" to include decisional law, also referred to as case law, (b) requiring airlines to investigate and remediate any release of

hazardous materials, (c) providing the Airport access to any premises for environmental inspections, and (d) clarifying that the airlines are fully responsible and liable for all costs attributable to hazardous materials resulting from airline activities.

In addition to the six differences discussed above which would impact the airlines with leases with the Airport, the proposed six new leases would require non-signatory airlines to pay a 25 percent premium on landing fees above the landing fees paid by the 25 airlines who will be under lease with the Airport, such that there would be a financial incentive for “non-signatory” airlines to enter into a lease with the Airport.

Modifications to Two Existing Leases (File 10-1214)

The other proposed resolution (File 10-1214) would approve modifications to two existing leases between the Airport and Alaska Airlines and Continental Airlines, which will expire on June 30, 2011. According to Mr. Franzella, as part of an incentive to airlines for agreeing to the new 2011 Lease and Use Agreements by February 2010, which would be effective from July 1, 2011 to June 30, 2021, the Airport offered all airlines the opportunity to reduce each airline’s current rental space in a “right-sizing” effort from their leased space. Two airlines, Alaska Airlines and Continental Airlines, agreed to new 2011 Lease and Use Agreements with the Airport in February 2010 and are now requesting lease modifications to right-size their current rental space.

According to data provided by the Airport, the proposed resolution would result in a reduction of 37,391 square feet or 5.1 percent of leased space, as shown in Table 1 below.

| | Total Sq. Ft. Under Existing Leases | Total Sq. Ft. Under Proposed Lease Modifications | Increase or (Decrease) | Percent Change |
|---------------------------|--|---|-------------------------------|-----------------------|
| Exclusive-Use Space | 73,857 | 48,907 | (24,950) | -33.8% |
| Shared-Use Space | 657,461 | 645,020 | (12,441) | -1.9% |
| Total Leased Space | 731,318 | 693,927 | (37,391) | -5.1% |

According to Mr. Franzella, both Alaska Airlines and Continental Airlines have requested to reduce exclusive-use space and shared-use space. Based on a total reduction of 37,391 square feet of exclusive-use and shared-use space, and assuming an effective date of November 1, 2010, the Airport will receive an estimated reduced rent of \$767,027 in FY 2010-2011 from the two airlines, including (a) \$79,251 in reduced rent from Alaska Airlines and (b) \$687,776 in reduced rent from Continental Airlines, as shown in Table 2 below.

In addition, although not part of the proposed resolution (File 10-1214), US Airways has also requested to reduce its permitted space at the Airport. As mentioned above, US Airways is currently a non-signatory airline and operates on a month-to-month permit basis. Because US Airways will become a signatory airline with the 2011 Lease and Use Agreement, the Airport allowed US Airways the opportunity to reduce its permitted space at the Airport. US Airways

will reduce its current permitted space by 4,781 square feet resulting in reduced rent payable to the Airport of \$140,338, as shown in Table 2 below.

| Airline | FY 2010-2011 Current Rental Revenue Paid to the Airport | FY 2010-2011 Modified Rental Revenue Paid to the Airport*** | Reduced Rental Revenue Payable to the Airlines |
|-----------------------|--|--|---|
| Alaska Airlines* | \$ 6,009,450 | \$ 5,930,199 | \$ 79,251 |
| Continental Airlines* | 8,269,248 | 7,581,472 | 687,776 |
| US Airways** | 7,574,580 | 7,434,242 | 140,338 |
| Total | \$ 21,853,278 | \$ 20,945,913 | \$ 907,365 |

* Alaska Airlines and Continental Airlines are currently signatory airlines and because they have leases with the Airport, lease modifications require resolutions subject to Board of Supervisors' approval.

** US Airways currently operates on a month-to-month permit basis and not on a lease. US Airways will become a signatory airline with the 2011 Lease (File 10-1213). Because US Airways agreed to a lease with the Airport, US Airways was allowed to reduce its current permitted space by 4,781 square feet.

*** Assumes an effective date of November 1, 2010 for the proposed lease modifications.

The total reduced rent to the Airport from Alaska Airlines (\$79,251), Continental Airlines (\$687,776), and US Airways (\$140,338), is \$907,365. However, as discussed above, such reductions in space will not result in reduced overall revenues to the Airport because the rental rates and fees paid by all airlines will be increased automatically under the Airport's residual rate setting methodology to fully offset the anticipated \$907,365 in reduced rental revenues, if the Airport is unable to find tenants for such vacated space.

The proposed resolution would also add several non-material modifications to bring each of these two leases into compliance with all applicable laws, including the Pesticide Prohibition, Tobacco Advertising Prohibition, and the First Source Hiring Ordinance.

FISCAL IMPACT

As shown in Table 3 below, the proposed six new lease agreements are estimated by the Airport to provide \$355,390,000 in total revenues to the Airport, over the ten-year lease term from July 1, 2011 through June 30, 2021.

| Fiscal Year | Estimated Total Rent Paid Under the Six Proposed Leases |
|--------------------|--|
| 2011-2012 | \$ 24,627,000 |
| 2012-2013 | 28,080,000 |
| 2013-2014 | 31,444,000 |
| 2014-2015 | 33,912,000 |
| 2015-2016 | 36,354,000 |
| 2016-2017 | 37,597,000 |
| 2017-2018 | 38,814,000 |
| 2018-2019 | 40,181,000 |
| 2019-2020 | 41,576,000 |
| 2020-2021 | 42,805,000 |
| Total | \$ 355,390,000 |

As discussed above, the revenues generated by both the current and proposed leases are calculated by the Airport's residual rate setting methodology (breakeven policy), such that the proposed new leases and modifications would continue to result in the Airport's budget being fully balanced by the revenues paid by the airlines to the Airport, after considering the Airport's budgeted expenditures and all non-airline revenues.

RECOMMENDATIONS

Approve the proposed resolutions.



San Francisco International Airport

P.O. Box 8097
San Francisco, CA 94128
Tel 650.821.5000
Fax 650.821.5000
www.flysfo.com

RECEIVED
BOARD OF SUPERVISORS
SAN FRANCISCO

SEP 15 PM 1:39

September 7, 2010

Ms. Angela Calvillo, Clerk of the Board
Board of Supervisors
City Hall
1 Dr. Carlton B. Goodlett Place, Room 244
San Francisco, CA 94102-4689

AIRPORT
COMMISSION
CITY AND COUNTY
OF SAN FRANCISCO

GAVIN NEWSOM
MAYOR

LARRY MAZZOLA
PRESIDENT

LINDA S. CRAYTON
VICE PRESIDENT

CARYL ITO

ELEANOR JOHNS

RICHARD J. GUGGENHIME

JOHN L. MARTIN
AIRPORT DIRECTOR

Subject: Approval of Modifications to Two (2) Airline/Airport Lease and Use Agreements between Alaska Airlines, Inc. and Continental Airlines, Inc. that Conduct Flight Operations at San Francisco International Airport and the City and County of San Francisco, acting by and through its Airport Commission

Dear Ms. Calvillo:

Pursuant to Section 9.118 of the City Charter, I am forwarding for the Board of Supervisors' approval modifications to two (2) Airline/Airport Lease and Use Agreements (the "Modifications"), to be effective July 1, 2010, between the City and County of San Francisco, acting by and through its Airport Commission, and Alaska Airlines, Inc. and Continental Airlines, Inc. that conduct flight operations at San Francisco International Airport, as described on Attachment A hereto. The Modifications were approved by Airport Commission Resolution Nos. 10-0280 and 10-0281, all adopted August 17, 2010.

On March 16, 2010 and May 11, 2010 the Lease Modifications between the City and twenty airlines was approved by the Airport Commission and Board of Supervisors, respectively related to becoming signatory to a new 2011 Lease with the Airport. These modifications provide for rental of approximately sixty-one thousand and twenty-five (61,025) square feet of Exclusive Use Space and six hundred thirty two thousand nine hundred ninety-four (632,994) square feet of Joint Use Space in the domestic and international terminals. The Modifications will be effective for the remainder of FY 2010/11 following Board of Supervisors approval, consistent with Rates and Charges for FY 2010/2011, and an annual rent projection of \$6,951,216. Both airlines have executed the 2011 Lease pending approval by the Board of Supervisors.

The following is a list of accompanying documents (five sets):

- Board of Supervisors Resolution; and
- Approved Airport Commission Resolutions No. 10-0280 through 10-0281; and
- Commission Memorandum; and
- Modifications to the Leases

You may contact Gary Franzella of the Airport Aviation Management Department at (650) 821-4525 regarding this matter.

Very truly yours,



Jean Caramatti
Commission Secretary

Enclosures

AIRPORT COMMISSION

CITY AND COUNTY OF SAN FRANCISCO

RESOLUTION NO. 10-0280

APPROVAL OF MODIFICATION NO. 7 TO ALASKA AIRLINES, INC. AIRLINE/AIRPORT LEASE AND USE AGREEMENT NO. L82-0314 TO PROVIDE FOR MODIFICATION OF TERMINAL SPACE RENTED IN TERMINAL 1 AND THE INTERNATIONAL TERMINAL IN RENTAL CATEGORIES I THROUGH V, AS APPLICABLE.

WHEREAS, Alaska Airlines, Inc. ("Alaska Airlines") conducts flight operations at San Francisco International Airport's Terminal 1 and the International Terminal pursuant to Airline/Airport Lease and Use Agreement No. L82-0314 (the "Lease"); and

WHEREAS, Alaska Airlines and the Airport Commission (the "Commission") of the City and County of San Francisco (the "City") desire to execute Modification No. 7 (the "Modification") in order to amend the terms of said Lease to reflect modified terminal rental space for the remainder of FY2010/11; and

WHEREAS, said Lease expires on June 30, 2011, and Alaska Airlines and the Commission and airlines have negotiated a new Lease and Use Agreement to take effect on July 1, 2011 (the "2011 Lease"), for a term of ten (10) years, and approval of the Modification is conditioned upon the full execution and delivery of such 2011 Lease to the Airport; and

WHEREAS, in order to facilitate the implementation of the 2011 Lease and the placement in service of new facilities, the Commission desires to authorize the Airport Director to enter into any additional non-material modifications to the Lease, including changes to the demised premises of not-to-exceed 10% of leased square footage, that the Airport Director determines, in consultation with the City Attorney, are in the best interests of the Commission, do not otherwise materially increase the obligations or liabilities of the Commission, are necessary or advisable to effectuate the purposes of the Lease or this Resolution, and are in compliance with all applicable laws, including City's Charter; now, therefore, be it

RESOLVED, that this Commission approves Modification No. 7 to Alaska Airlines' Lease and Use Agreement No. L82-0314 consistent with the terms of the attached memorandum; and be it further

RESOLVED, that this Commission authorizes the Airport Director to execute said Modification and to enter into any additional non-material modifications to the Lease, including changes to the demised premises of not-to-exceed 10% of leased square footage, as described above; and be it further

RESOLVED, that the Commission Secretary is hereby directed to request Board of Supervisors' approval of said Modification pursuant to City Charter Section 9.118.

*I hereby certify that the foregoing resolution was adopted by the Airport Commission
at its meeting of _____*

AUG 17 2010

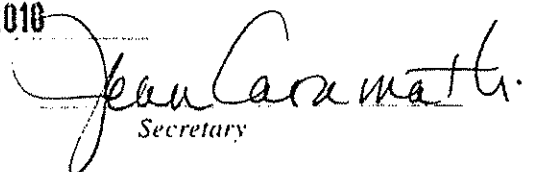
Secretary

AIRPORT COMMISSION

CITY AND COUNTY OF SAN FRANCISCO

RESOLUTION NO. 10-0281

**APPROVAL OF MODIFICATION NO. 5 TO CONTINENTAL AIRLINES, INC.
AIRLINE/AIRPORT LEASE AND USE AGREEMENT NO. L82-0316 TO PROVIDE FOR
MODIFICATION OF TERMINAL SPACE RENTED IN TERMINAL 1 IN RENTAL
CATEGORIES I THROUGH V, AS APPLICABLE.**

- WHEREAS,** Continental Airlines, Inc. (“**Continental Airlines**”) conducts flight operations at San Francisco International Airport’s Terminal 1 pursuant to Airline/Airport Lease and Use Agreement No. L82-0316.(the “**Lease**”); and
- WHEREAS,** Continental Airlines and the Airport Commission (the “**Commission**”) of the City and County of San Francisco (the “**City**”) desire to execute Modification No. 5 (the “**Modification**”) in order to amend the terms of said Lease to reflect modified terminal rental space for the remainder of FY2010/11; and
- WHEREAS,** said Lease expires on June 30, 2011, and Continental Airlines and the Commission and airlines have negotiated a new Lease and Use Agreement to take effect on July 1, 2011 (the “**2011 Lease**”), for a term of ten (10) years, and approval of the Modification is conditioned upon the full execution and delivery of such 2011 Lease to the Airport; and
- WHEREAS,** in order to facilitate the implementation of the 2011 Lease and the placement in service of new facilities, the Commission desires to authorize the Airport Director to enter into any additional non-material modifications to the Lease, including changes to the demised premises of not-to-exceed 10% of leased square footage, that the Airport Director determines, in consultation with the City Attorney, are in the best interests of the Commission, do not otherwise materially increase the obligations or liabilities of the Commission, are necessary or advisable to effectuate the purposes of the Lease or this Resolution, and are in compliance with all applicable laws, including City’s Charter; now, therefore, be it
- RESOLVED,** that this Commission approves Modification No. 5 to Continental Airlines’ Lease and Use Agreement No. L82-0316 consistent with the terms of the attached memorandum; and be it further
- RESOLVED,** that this Commission authorizes the Airport Director to execute said Modification and to enter into any additional non-material modifications to the Lease, including changes to the demised premises of not-to-exceed 10% of leased square footage, as described above; and be it further
- RESOLVED,** that the Commission Secretary is hereby directed to request Board of Supervisors’ approval of said Modification pursuant to City Charter Section 9.118.

*I hereby certify that the foregoing resolution was adopted by the Airport Commission
at its meeting of _____*

AUG 17 2010

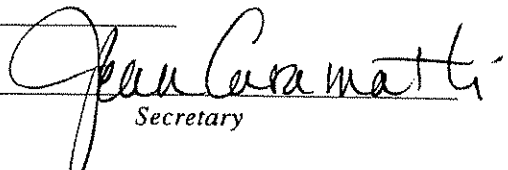
Secretary



San Francisco International Airport

MEMORANDUM

August 17, 2010

P.O. Box 8097
San Francisco, CA 94128
Tel 650.821.5000
Fax 650.821.5005
www.flysfo.com

TO: AIRPORT COMMISSION
Hon. Larry Mazzola, President
Hon. Linda S. Crayton, Vice President
Hon. Caryl Ito
Hon. Eleanor Johns
Hon. Richard J. Guggenhime

FROM: Airport Director

SUBJECT: Lease Modifications Related to 2011 Lease Signatories

DIRECTOR'S RECOMMENDATION: ADOPT THE ACCOMPANYING RESOLUTIONS THAT AUTHORIZE MODIFICATIONS OF THE AIRLINE/AIRPORT LEASE AND USE AGREEMENTS FOR ALASKA AIRLINES, INC. AND CONTINENTAL AIRLINES, INC.

Executive Summary

On July 1, 2011, all 1981 Airline/Airport Lease and Use Agreements and 1999 Lease and Operating Agreements will expire. The Airport and airlines have negotiated a new Lease and Use Agreement to be effective July 1, 2011 (the "2011 Lease"). As an incentive to sign the 2011 Lease early, the airlines are being provided with the opportunity to "right size" their leased space pursuant to a modification to the existing agreements effective upon full execution by the parties subject to this approval, final approval by the Board of Supervisors and return of possession of the space to be right sized. Staff is seeking approval of modifications to the Airline/Airport Lease and Use Agreement of Alaska Airlines, Inc. ("Alaska") and Continental Airlines, Inc. ("Continental") contingent upon a concurrent approval of the 2011 Lease by the Commission and Board of Supervisors.

Background

Most of the airlines operating at the San Francisco International Airport, (the "Airport") are parties to a lease which expires on June 30, 2011. Over the past several years, Airport staff has negotiated the terms of a 2011 Lease which will take effect on July 1, 2011, and has been made available to all airlines who wish to maintain or obtain signatory status at the Airport. In order to accommodate the current challenging business environment within the aviation industry, the airlines have

AIRPORT
COMMISSION
CITY AND COUNTY
OF SAN FRANCISCO

GAVIN NEWSOM
MAYOR

LARRY MAZZOLA
PRESIDENT

LINDA S. CRAYTON
VICE PRESIDENT

CARYL ITO

ELEANOR JOHNS

RICHARD J. GUGGENHIME

JOHN L. MARTIN
AIRPORT DIRECTOR

requested and been offered, as an incentive to sign the 2011 Lease, the opportunity to reduce their current space rental in a "right sizing" effort, and to remove the Explosive Detection System (EDS) space from their leased space pursuant to the existing leases, upon full approval the lease modification and subsequent return of possession of the space to be right sized. Such reductions effect both Exclusive Use Space and Joint Use Space.

Only those airlines who sign the 2011 Lease will be allowed to right-size their leased space in this manner. These space changes are to be accomplished by a modification to each of the existing leases. For the remaining term of their current lease, following full City approval, the airlines will pay rent for terminal space at Rates and Charges for Categories I through V, as specified on Attachment A, attached hereto.

Each airline operating at the Airport has been offered the opportunity to become a signatory to the 2011 Lease that will take effect on July 1, 2011. On March 16, 2010, pursuant to Resolutions 10-0100 through 10-0119, the Airport Commission approved twenty four (24) modifications of either the 1981 Airline/Airport Lease and Use Agreement or the 1999 Lease and Operating Agreement, which subsequently received approval by the Board of Supervisors pursuant to Resolution 207-10. Subsequent to these initial approvals, Alaska and Continental executed their respective modifications and the 2011 Lease in order to implement the changes to the leased premises outlined above. The modification for Alaska also provides for an increase of sixty four (64) square feet of Category I space.

Staff is now seeking Commission approval to modify Lease and Use Agreement L82-0314 with Alaska and Lease and Use Agreement L82-0316 with Continental. Each lease modification will take effect upon full execution by the parties subject to this approval and final approval by the Board of Supervisors and return of possession of the space to be right sized. Rent will be charged in accordance with the FY 10/11 Airport Rates and Charges for the remaining year under each current lease. In order to facilitate the implementation of the new 2011 Leases and the placement in service of the renovated Terminal 2, the attached resolutions also authorize the Airport Director, in consultation with the City Attorney, to make any additional non-material modifications (including changes to the demised premises of not-to-exceed 10% of leased square footage) to the current leases as are in the City's best interest and necessary to effectuate the purposes of the existing leases or Commission resolutions, and as are in compliance with all applicable laws, including the City Charter.

All of the airlines are obligated to be in compliance with or obtain an exemption from the requirements of the Equal Benefits Ordinance and other City contracting requirements.

Approval of these resolutions is contingent upon a concurrent approval of the resolutions approving the 2011 Lease, which resolutions are calendared simultaneously for Commission consideration today.

Recommendation

I recommend adoption of the accompanying resolutions that authorize the Director to execute; (1) Modifications to the 1981 Lease and Use Agreement for Alaska Airlines and Continental Airlines, as summarized on Attachment A; and (2) directing the Commission Secretary to request Board of Supervisors' approval of such lease modifications in accordance with City Charter Section 9.118.



John L. Martin
Airport Director

Prepared by: Leo Fermin
Deputy Airport Director
Business and Finance

Attachments

ATTACHMENT A

**Airline 1981 Lease & Use Agreement Modifications
 Exclusive Use Space (in square feet)**

| | Airline | Lease # | Mod. # | Changes in Categories of Rent | | | | |
|---|----------------------|------------|--------|-------------------------------|--------|---------|--------|-------|
| | | | | Cat I | Cat II | Cat III | Cat IV | Cat V |
| 1 | Alaska Airlines | L82 - 0314 | 7 | 4,776 | 5,660 | 878 | 4,905 | - |
| 2 | Continental Airlines | L82 - 0316 | 5 | 8,675 | 12,500 | 11,139 | 7,543 | 4,949 |

**Airline 1981 Lease and Use Agreement Modifications
 and
 Joint Use Space (in square feet)**

| Joint Use Space | Categories of Rent | | | | |
|-------------------------------|--------------------|---------|---------|---------|-------|
| | Cat I | Cat II | Cat III | Cat IV | Cat V |
| <i>International Terminal</i> | | | | | |
| Total = 631,987 square feet | 138,367 | 214,307 | 12,025 | 265,400 | 1,888 |
| <i>Terminal 1</i> | | | | | |
| Total = 1,007 square feet | - | 216 | - | 791 | - |

MODIFICATION NO. 7 TO
AIRLINE-AIRPORT LEASE AND USE AGREEMENT
SAN FRANCISCO INTERNATIONAL AIRPORT
ALASKA AIRLINES, INC.

THIS MODIFICATION OF AGREEMENT (this "**Modification**") dated as of July 1, 2010, is entered into by and between the City and County of San Francisco, acting by and through its Airport Commission ("**City**"), and Alaska Airlines, Inc., ("**Airline**").

Recitals

A. The City and County of San Francisco owns San Francisco International Airport (the "**Airport**") located in the County of San Mateo, State of California, which Airport is operated by and through the Airport Commission, the chief executive officer of which is the Airport Director.

B. Pursuant to that certain Airline-Airport Lease and Use Agreement L-82-0314, dated as of July 1, 1981, Airline leases from City certain premises located at the Airport. Such Lease and Use Agreement has been modified and amended previously pursuant to the modifications and amendments listed on the attached *Appendix A*. As used below, the term "**Agreement**" shall mean the Lease and Use Agreement, as amended and modified by the agreements described on *Appendix A* and this Modification.

C. The Agreement expires on June 30, 2011 and the City is currently negotiating a new Lease and Use Agreement with the airlines operating at the Airport, which agreement will be effective July 1, 2011 and have a term of ten (10) years.

D. In consideration for execution of the new Lease and Use Agreement on or before February 26, 2010, the City has agreed to allow the airlines to remove certain Category II and Category IV Joint Use Space relating to Explosive Detection System devices in the Domestic Terminal and International Terminal of their Exclusive Use and Joint Use Space.

E. Airline has executed the new Lease and Use Agreement and is therefore eligible to relinquish a portion of the Demised Premises of the Agreement pursuant to this Modification.

F. Airline and City now desire to modify the terms of the Agreement to reflect such relinquishment and addition of leasehold space.

G. Pursuant to the Commission Resolution, the Airport Commission has determined that entering into this Modification is in the best interest of City, and has authorized execution of this Modification. Pursuant to the Board Resolution, the City's Board of Supervisors has authorized the execution of the Modification.

NOW THEREFORE, in consideration of the foregoing and of the mutual covenants set forth herein, and other good and valuable consideration, receipt of which is hereby acknowledged, the parties do mutually agree as follows:

1. Effective Date; Defined Terms.

(a) The effective date (the "Effective Date") of this Modification shall be the date on which all of the following conditions are satisfied: (1) the Airport Commission and Board of Supervisors shall have approved this Modification; (2) both parties have executed this Modification, (3) Airline has returned possession of the relinquished space(s) to City and City has accepted such possession.

Actual Date: _____ (to be inserted upon determination)

(b) The "Reduction Date" of the relinquished space shall be the date on which Airline has surrendered the space, as determined by the City. On or before the Reduction Date, Airline shall surrender the relinquished space(s) in the condition required by the Agreement. Without limiting the generality of the foregoing, Airline shall remove all movable furniture and trade fixtures.

(c) Capitalized terms not defined herein shall have the meanings given them in the Agreement.

2. Airline's Exclusive Use Space in Terminal 1, as defined in Modification No. 6 of the Agreement, including in Section 2 and Exhibit F, is modified as follows:

(a) 373 square feet of Category II space in Terminal 1 is deleted, as described on Airport Drawing No. T12ASPER dated September 18, 2007.

(b) 1,581 square feet of Category IV space relating to EDS Space in Terminal 1 is deleted as described on Airport Drawing No. T11AS, dated September 18, 2007.

(c) 82 square feet of Category I space in Terminal 1 is added as described in Airport Drawing No. T12AS dated July 1, 2010.

(d) For the purpose of the Modification, all *Exhibits* to the Agreement relating to Exclusive Use Space in Terminal 1 are deleted in their entirety and substituted with *Drawing Numbers T11AS, T11ASBB, T12AS and T12BABAS*, dated July 1, 2010.

(e) As modified hereby, Airline's Exclusive Use Space in Terminal 1 comprises the following areas, all as shown on *Drawing Numbers T11AS, T11ASBB, T12AS and T12BABAS*, dated July 1, 2010, attached hereto:

Terminal 1

| Cat. | Square Feet |
|-------------|--------------------|
| I | 4,776 |
| II | 5,660 |
| III | 878 |
| IV | 4,905 |

3. Airline's Joint Use Space in Terminal 1, as defined in Modification No. 6 of the Agreement, including in Section 2 and Exhibit F, shall remain at 791 square feet.

4. Airline's Joint Use Space in the International Terminal, as defined in Modification No. 5 of the Agreement, including in Section 1.125 and Exhibit F, is modified as follows:

(a) 1,258 square feet of Category II space relating to EDS Space in the International Terminal is deleted, as described on Airport Drawing No. IT1JT dated September 12, 2000, Exhibit F-IJU5.

(b) 7,130 square feet of Category IV space relating to EDS Space in the International Terminal is deleted, as described on Airport Drawing No. IT1JT dated September 12, 2000, Exhibit F-IJU5.

(c) For the purpose of this Modification, all *Exhibits* to the Agreement relating to Joint Use Space are deleted in their entirety and substituted with *Drawing Numbers IT1JT, IT2JT, IT3JT, BAA1JT, BAA2JT, BAA2MJT, BAA3JT, BAG1JT, BAG2JT AND BAG3JT*, dated July 1, 2010 to reflect the current use of the Joint Use Space.

(d) As modified hereby, Airline's Joint Use Space comprises the following areas, all as shown on *Drawing Numbers IT1JT, IT2JT, IT3JT, BAA1JT, BAA2JT, BAA2MJT, BAA3JT, BAG1JT, BAG2JT AND BAG3JT*, dated July 1, 2010 are attached hereto:

Joint Use Space

| Type | Category* (J/U type) | | Square Feet |
|--|-------------------------|-----|-------------|
| Holdroom/Ticket Counter | I | (e) | 138,367 |
| Baggage Claim/FIS | II | (d) | 205,711 |
| Other Common Use, Level 1 and 3+ | | | 544 |
| Domestic Bag Claim | II | (t) | 8,052 |
| Other Enclosed Common Use, Level 2 and below | III | (t) | 12,025 |
| Inbound Baggage Makeup | IV | (d) | 126,574 |
| Outbound Baggage Makeup | IV | (e) | 138,826 |
| Other Unenclosed Space | V | (t) | 1,888 |

* The Category references are utilized in the ITB Joint Use Formulas.

5. **Miscellaneous Provisions.** The following provision(s) 5.1 through 5.10 shall be added to the Agreement:

5.1 **No Advertising or Promotions; Prohibition of Tobacco Advertising.** Airline shall have no right to conduct any advertising or promotional activities on the Airport. Airline acknowledges and agrees that no advertising of cigarettes or tobacco products is allowed on any real property owned by or under the control of the City, including the Demised Premises and the Airport. This prohibition includes the placement of the name of a company producing, selling or distributing cigarettes or tobacco products or the name of any cigarette or tobacco product in any promotion of any event or product. This prohibition does not apply to any advertisement sponsored by a state, local or nonprofit entity designed to communicate the health hazards of cigarettes and tobacco products or to encourage people not to smoke or to stop smoking.

5.2 First Source Hiring Ordinance. The City has adopted a First Source Hiring Ordinance (Board of Supervisors Ordinance No. 264 -98) which establishes specific requirements, procedures and monitoring for first source hiring of qualified, economically disadvantaged individuals for entry level positions. Within thirty (30) days after the Real Estate Division of the Department of Administrative Services adopts a First Source Hiring Implementation and Monitoring Plan in accordance with the First Source Hiring Ordinance, Airline shall enter into a First Source Hiring Agreement that meets the applicable requirements of Section 83.9 of the First Source Hiring Ordinance.

5.3 Sunshine Ordinance. In accordance with Section 67.24(e) of the San Francisco Administrative Code, contracts, contractors' bids, leases, agreements, responses to Requests for Solicitations, and all other records of communications between City and persons or firms seeking contracts will be open to inspection immediately after a contract has been awarded. Nothing in this provision requires the disclosure of a private person's or organization's net worth or other proprietary financial data submitted for qualification for a contract, lease, agreement or other benefit until and unless that person or organization is awarded the contract, lease, agreement or benefit. Information provided which is covered by this Section will be made available to the public upon request.

5.4 Charter Provisions. This Agreement is governed by and subject to the provisions of the City Charter.

5.5 Notification of Limitations on Contributions. Through its execution of this Agreement, Airline acknowledges that it is familiar with Section 1.126 of the San Francisco Campaign and Governmental Conduct Code, which prohibits any person who contracts with the City for the selling or leasing any land or building to or from the City whenever such transaction would require approval by a City elective officer or the board on which that City elective officer serves, from making any campaign contribution to the officer at any time from the commencement of negotiations for such contract until the termination of negotiations for such contract or three (3) months has elapsed from the date the contract is approved by the City elective officer, or the board on which that City elective officer serves.

5.6 Compliance with Laws. Airline shall keep itself fully informed of the City Charter, codes, ordinances and regulations of the City and of all State, and federal laws in any manner applicable to the performance of this Agreement, and must at all times comply with such applicable local codes, ordinances, and regulations and all applicable laws as they may be amended from time to time.

5.7 Airport Intellectual Property. Pursuant to Resolution No. 01-0118, adopted by the Airport Commission on April 18, 2001, the Airport Commission affirmed that it will not tolerate the unauthorized use of its intellectual property, including the SFO logo, CADD designs, and copyrighted publications. All proposers, bidders, contractors, tenants, permittees, and others doing business with or at the Airport (including subcontractors and subtenants) may not use the Airport intellectual property, or any intellectual property confusingly similar to the Airport intellectual property, with the Airport Director's prior consent.

5.8 Food Service Waste Reduction. If and to the extent applicable, the Airline agrees to comply fully with and be bound by all of the applicable provisions of the Food Service Waste Reduction Ordinance, as set forth in the San Francisco Environment Code, Chapter 16, including the remedies provided therein, and implementing guidelines and rules. The provisions of Chapter 16 are incorporated herein by reference and made a part of this Agreement as though fully set forth herein. Accordingly, Airline acknowledges that City contractors and lessees may not use Disposable Food Service Ware that contains Polystyrene Foam in City Facilities and while performing under a City contract or lease, and shall instead use suitable Biodegradable/Compostable or Recyclable Disposable Food Service Ware. This provision is a material term of this Agreement. By entering into this agreement, Airline agrees that if it

breaches this provision, City will suffer actual damages that will be impractical or extremely difficult to determine; further, Airline agrees that the sum of one hundred dollars (\$100.00) liquidated damages for the first breach, two hundred dollars (\$200.00) liquidated damages for the second breach in the same year, and five hundred dollars (\$500.00) liquidated damages for subsequent breaches in the same year is a reasonable estimate of the damage that City will incur based on the violation, established in light of the circumstances existing at the time this agreement was made. Such amounts shall not be considered a penalty, but rather agreed monetary damages sustained by City because of Airline's failure to comply with this provision.

5.9 Labor Disputes. Airline agrees to use commercially reasonable efforts to avoid disruption to City, other Air Carriers, Airport tenants, or members of the public arising from labor disputes involving Airline, and in the event of a strike, picketing, demonstration or other labor difficulty involving Airline, to use commercially reasonable efforts, including the utilization of available legal remedies, to minimize or eliminate any disruption to City, other Air Carriers, Airport tenants, or members of the public, arising from such strike, picketing, demonstration or other labor difficulty.

5.10 Preservative-Treated Wood Containing Arsenic. As of July 1, 2003, Airline may not purchase preservative-treated wood products containing arsenic in the performance of this Agreement unless an exemption from the requirements of Environment Code Chapter 13 is obtained from the Department of Environment under Section 1304 of the Environment Code. The term "preservative-treated wood containing arsenic" shall mean wood treated with a preservative that contains arsenic, elemental arsenic, or an arsenic copper combination, including, but not limited to, chromated copper arsenate preservative, ammoniac copper zinc arsenate preservative, or ammoniacal copper arsenate preservative. Airline may purchase preservative-treated wood products on the list of environmentally preferable alternatives prepared and adopted by the Department of Environment. This provision does not preclude Airline from purchasing preservative-treated wood containing arsenic for saltwater immersion. The term "saltwater immersion" shall mean a pressure-treated wood that is used for construction purposes or facilities that are partially or totally immersed in saltwater.

6. **Modification.** As modified hereby, the Agreement remains in full force and effect.

///

X:\TENANTS\AIRLINES\LEASES\2010 Lease Modifications\2010 Lease Mod L&U as amended for ITB - Alaska Mod 7.DOC

IN WITNESS WHEREOF, the parties hereto have executed this Modification as of the date first written above.

AIRLINE: Alaska Airlines, Inc.,
a Alaska corporation

By: William S. Ayer
Name: William S. Ayer
Title: Chairman & CEO

By: _____
Name: _____
Title: _____

CITY: CITY AND COUNTY OF SAN FRANCISCO,
a municipal corporation,
acting by and through its Airport Commission

John L. Martin
Airport Director

AUTHORIZED BY AIRPORT
COMMISSION

Resolution No. _____

Adopted: _____

Attest: _____

Secretary
Airport Commission

Approved by Board of Supervisors on
_____, pursuant to Resolution
No. _____

APPROVED AS TO FORM:
DENNIS J. HERRERA,
City Attorney

By _____
Deputy City Attorney

APPENDIX A

MODIFICATIONS TO LEASE AND USE AGREEMENT

ALASKA AIRLINES, INC.

| <u>Modification</u> | <u>Date</u> | <u>Resolution Number</u> |
|-----------------------|--|--|
| Modification Number 1 | November 17, 1987 | Commission Resolution Number: 87-0247 |
| Modification Number 2 | | Commission Resolution Number: 88-0091 |
| Modification Number 3 | December 6, 1988 March 9, 1989 | Commission Resolution Number: 88-0216 Board Resolution Number: 160-89 |
| Modification Number 4 | April 6, 1993 May 25, 1993 | Commission Resolution Number: 93-0074 Board Resolution Number: 138-93 |
| Modification Number 5 | September 21, 1999 January 21, 2000 | Commission Resolution Number: 99-0306 Board Resolution Number: 21-00 |
| Modification Number 6 | May 15, 2007 October 22, 2007 | Commission Resolution Number: 07-0119 Board Resolution Number: 560-07 |

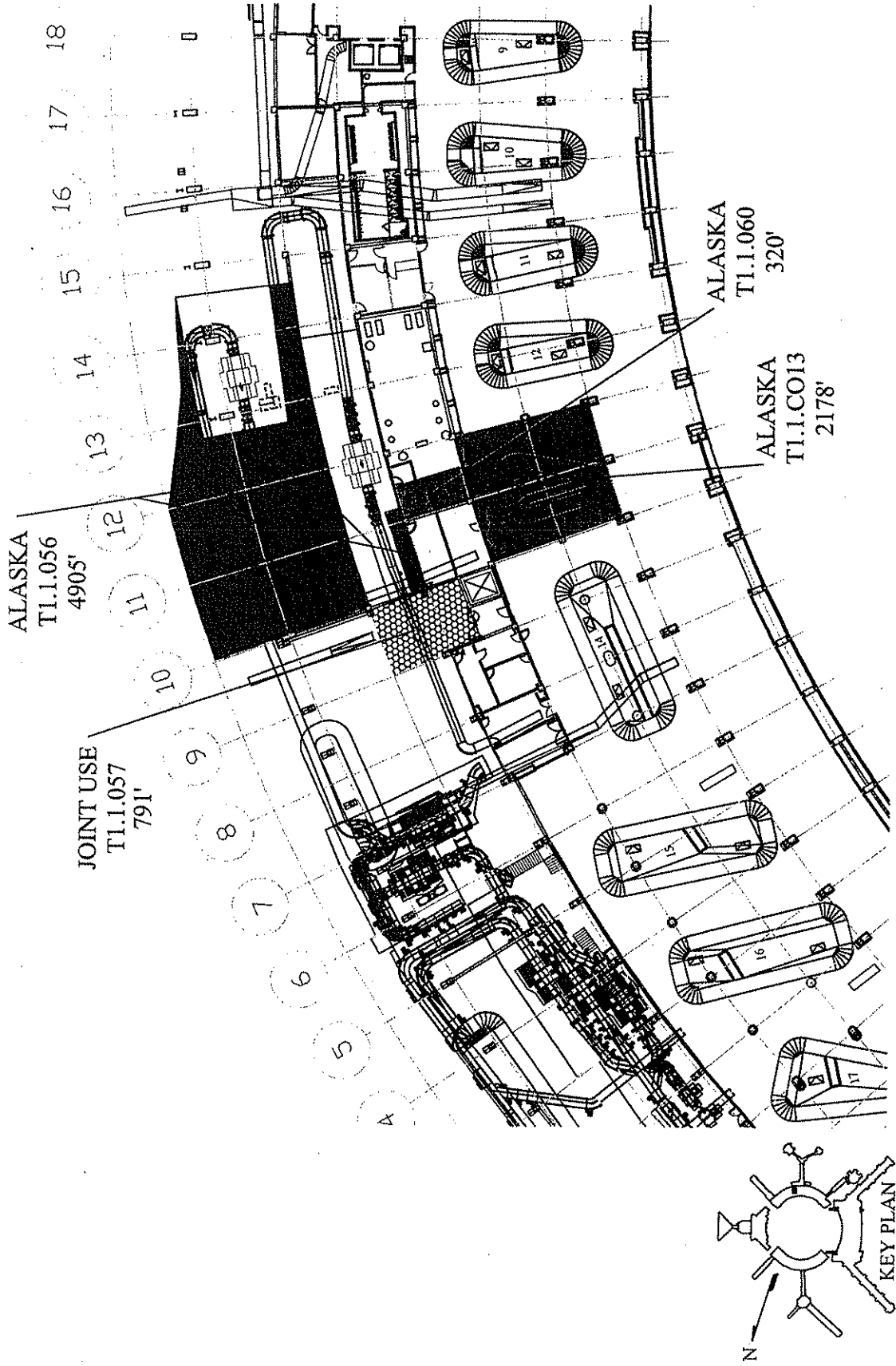

TENANT LOCATION LEASE DRAWING

LOCATION: TERMINAL 1 AT BOARDING AREA B - 1ST FLOOR
 ALASKA AIRLINES
 CITY & COUNTY OF SAN FRANCISCO DWG: T11AS
 AIRPORTS COMMISSION SCALE: 1/8"=1'-0"
 SAN FRANCISCO INTERNATIONAL AIRPORT DATE: 07/01/2010

| LOCATION | TENANT | CAT | AREA | CONTRACT | EFF DATE |
|-----------|--------|-----|-------|----------|----------|
| T1.1.056 | AS | 4 | 4905' | 82-0314 | |
| T1.1.060 | AS | 2 | 320' | 82-0314 | |
| T1.1.COI3 | AS | 2 | 2178' | 82-0314 | |
| T1.1.057 | JT USE | 4 | 791' | 82-0314 | |

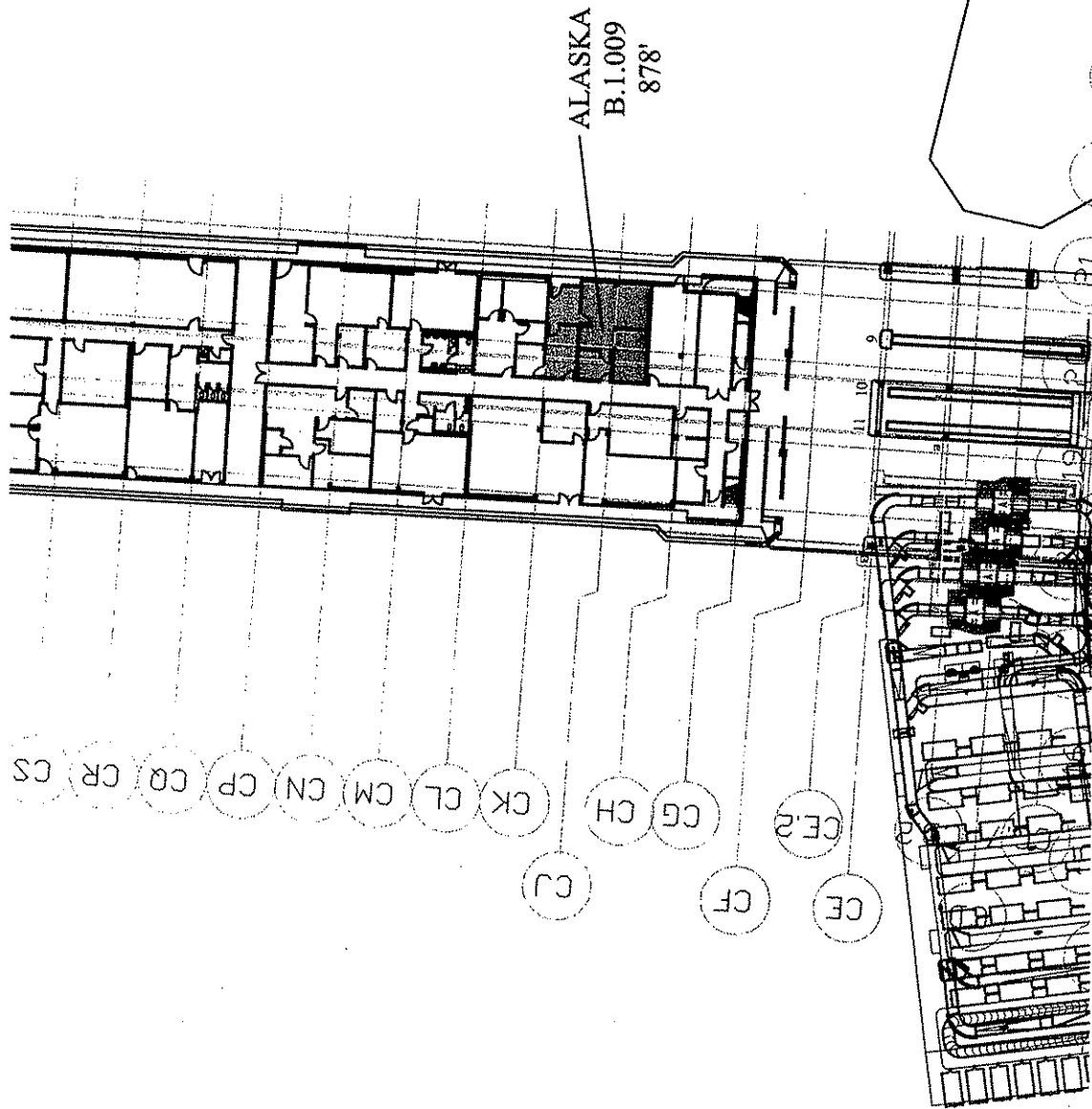

ALASKA
B.1.009
878'

| TENANT LOCATION PERMIT DRAWING | | LOCATION | TENANT | CAT | AREA | CONTRACT | EFF DATE |
|--|------------------|----------|--------|-----|------|----------|----------|
| | | B.1.009 | AS | 3 | 878' | 82-0314 | |
| LOCATION: TERMINAL I BOARDING AREA B - 1ST FLOOR | | | | | | | |
| ALASKA AIRLINES | | | | | | | |
| CITY & COUNTY OF SAN FRANCISCO | DWG: T11ASBB | | | | | | |
| AIRPORTS COMMISSION | SCALE: 1"=50' | | | | | | |
| SAN FRANCISCO INTERNATIONAL AIRPORT | DATE: 07/01/2010 | | | | | | |



TENANT LOCATION LEASE DRAWING

| LOCATION | TENANT | CAT | AREA | CONTRACT | EFF DATE |
|-----------|--------|-----|-------|-----------|----------|
| T1.2.066 | AS | 1 | 389' | L-82-0314 | |
| T1.2.066B | AS | 1 | 23' | L-07-043 | |
| T1.2.077 | AS | 2 | 1063' | L-82-0314 | |
| T1.2.088 | AS | 2 | 218' | L-82-0314 | |

| | |
|-------------------------------------|------------------|
| LOCATION: TERMINAL 1 - 2ND FLOOR | |
| ALASKA AIRLINES | |
| CITY & COUNTY OF SAN FRANCISCO | DWG: T12AS |
| AIRPORTS COMMISSION | SCALE: 1"=50' |
| SAN FRANCISCO INTERNATIONAL AIRPORT | DATE: 07/01/2010 |

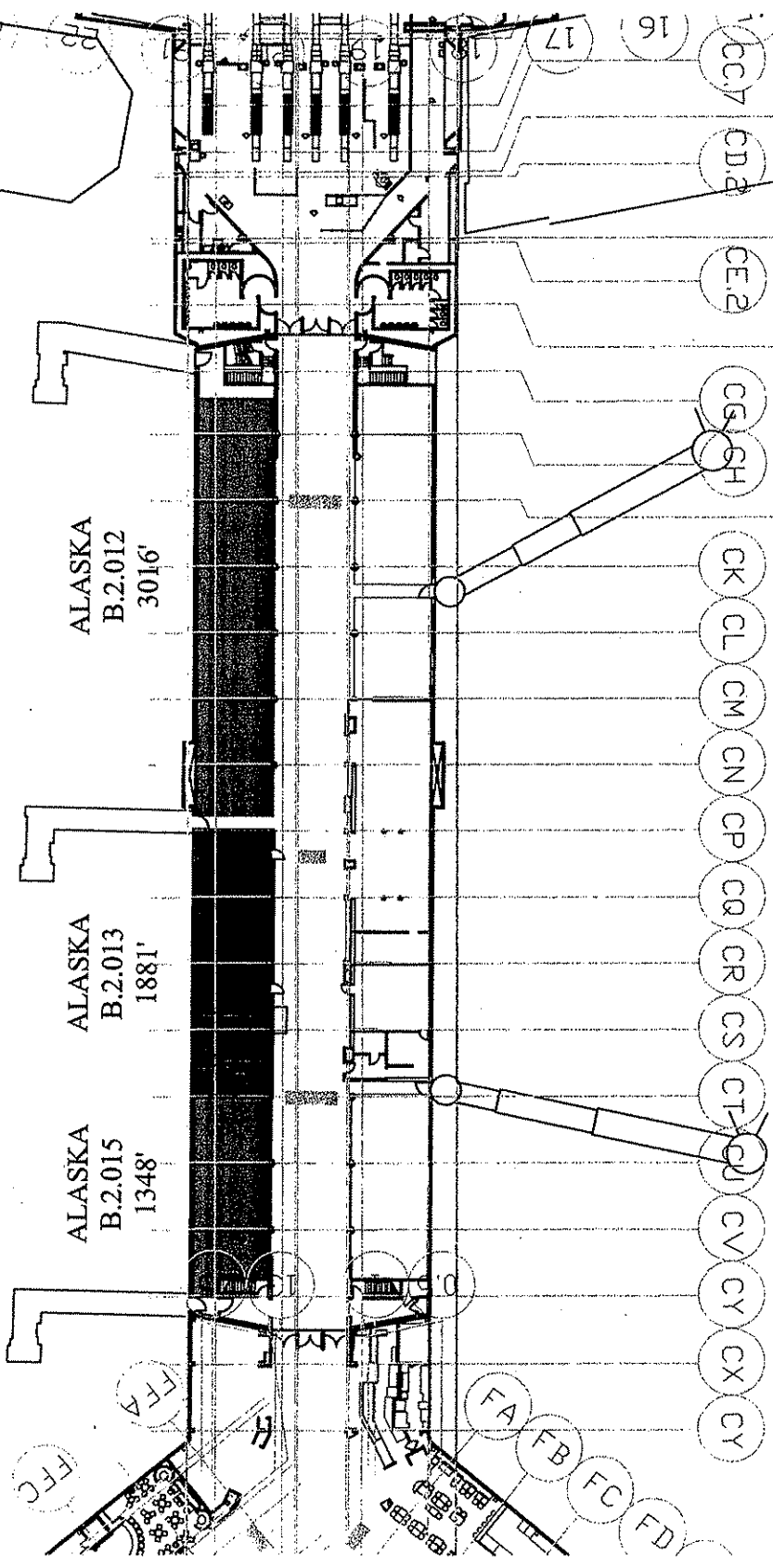

NOTE: 4 FEET CLEAR PATH
TO JETBRIDGE DOOR, TYPICAL

| TENANT LOCATION LEASE DRAWING | | LOCATION | TENANT | CAT | AREA | CONTRACT | EFF DATE |
|---|--|----------|--------|-----|-------|-----------|----------|
| LOCATION: TERMINAL I - BOARDING AREA B, 2ND FLOOR ALASKA AIRLINES CITY & COUNTY OF SAN FRANCISCO DWG: T12BABAS AIRPORTS COMMISSION SCALE: 1/8"=1'-0" SAN FRANCISCO INTERNATIONAL AIRPORT DATE: 07/01/2010 | | B.2.012 | AS | 1 | 3016' | L-82-0314 | |
| | | B.2.013 | AS | 2 | 1881' | L-82-0314 | |
| | | B.2.015 | AS | 1 | 1348' | L-82-0314 | |

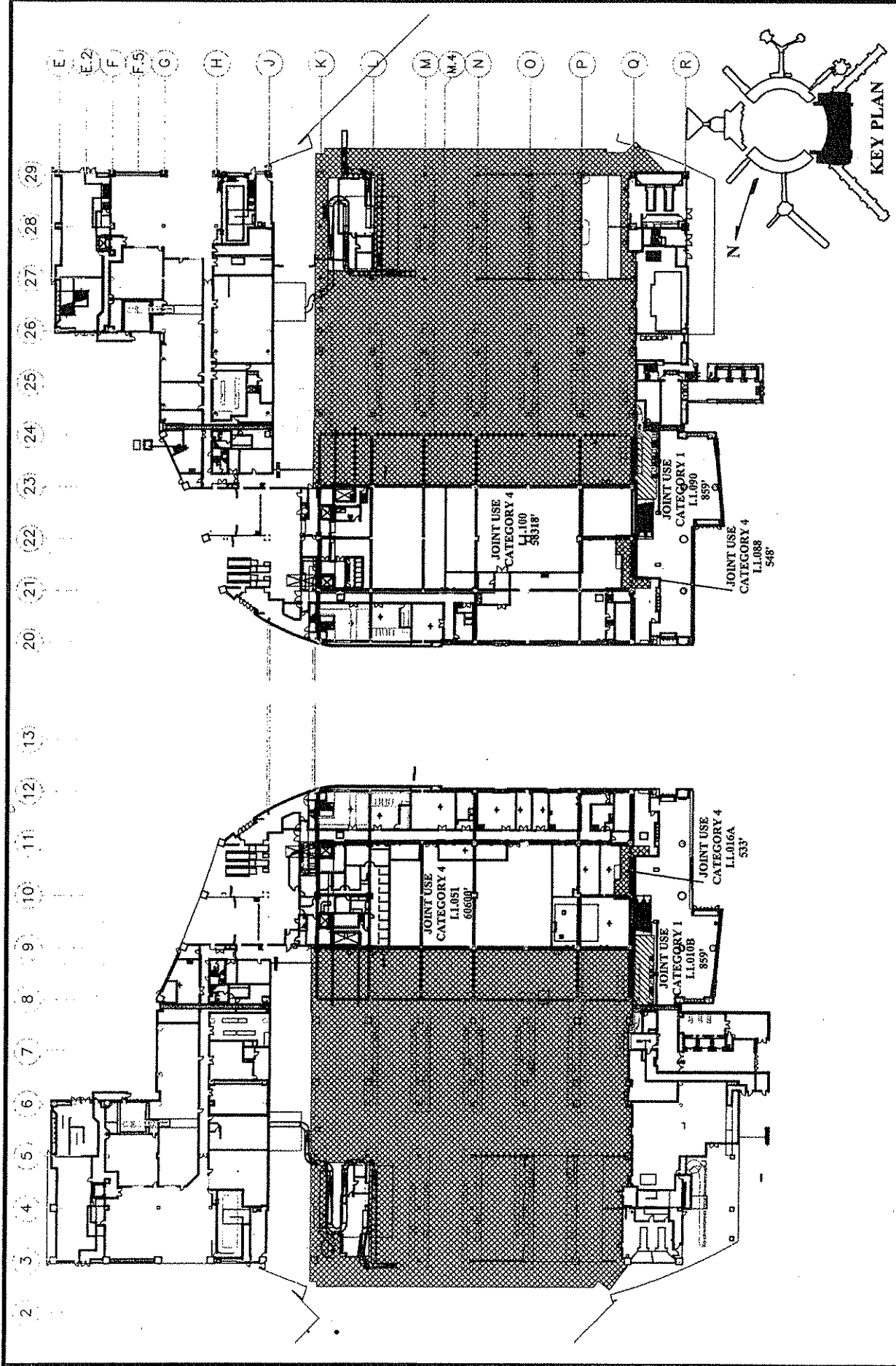

| TENANT LOCATION LEASE DRAWING | | LOCATION | TENANT | CAT | AREA | CONTRACT | EFF DATE |
|---|--|----------|-----------|-----|---------|----------|----------|
| LOCATION: INTERNATIONAL TERMINAL, 1ST FLOOR | | | JOINT USE | 1 | 1718' | | |
| ALL INTERNATIONAL AIRLINES | | | JOINT USE | 4 | 119999' | | |
| CITY & COUNTY OF SAN FRANCISCO | | | | | | | |
| AIRPORTS COMMISSION | | | | | | | |
| SAN FRANCISCO INTERNATIONAL AIRPORT | | | | | | | |
| DWG: IT1JT | | | | | | | |
| SCALE: 1/8"=1'-0" | | | | | | | |
| DATE: 07/01/2010 | | | | | | | |

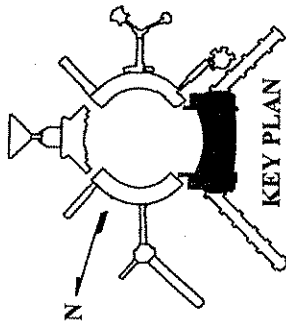
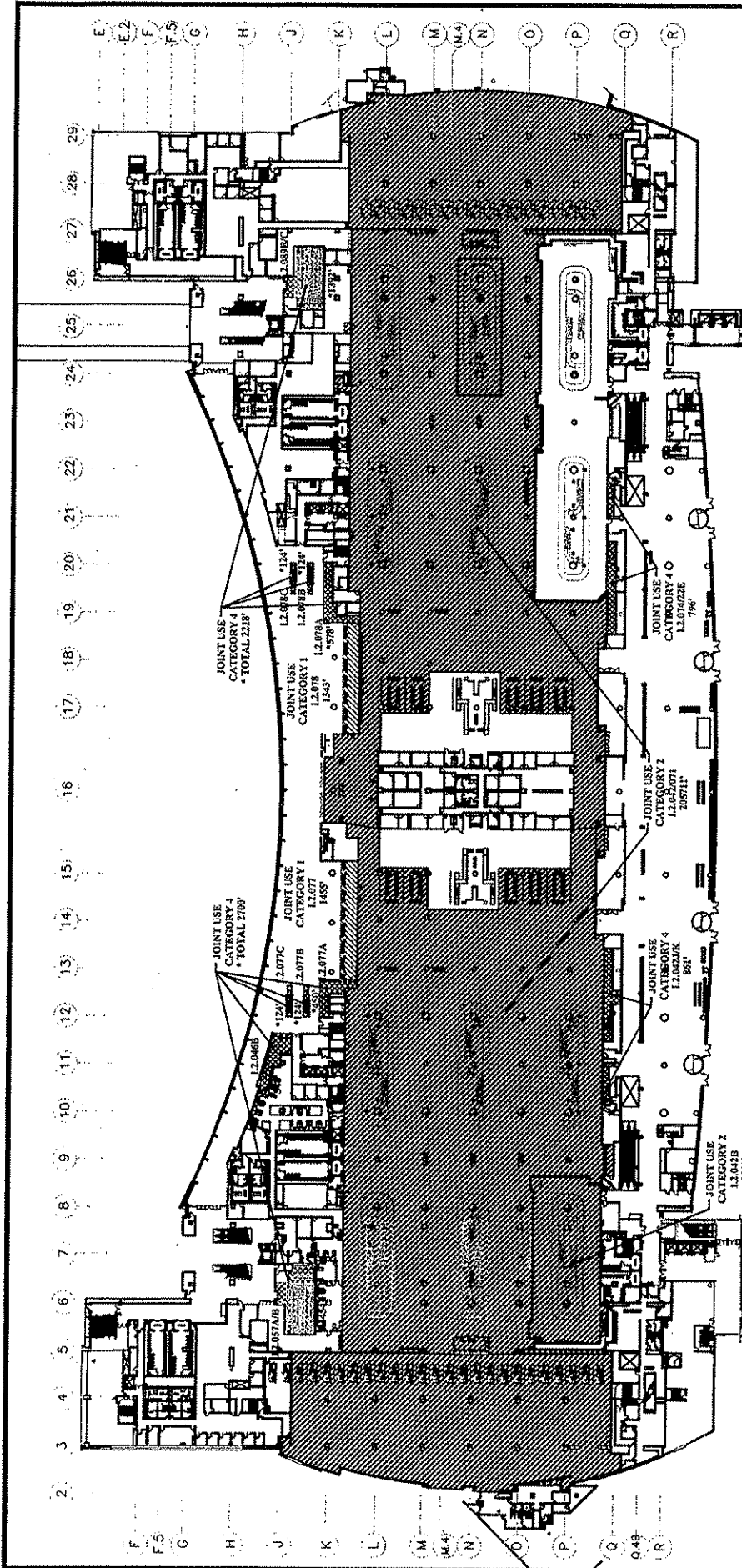

| TENANT LOCATION LEASE DRAWING | | LOCATION | TENANT | CAT | AREA | CONTRACT | EFF DATE |
|---|--|----------|-----------|-----|---------|----------|----------|
| LOCATION: INTERNATIONAL TERMINAL, 2ND FLOOR, CENTER | | | JOINT USE | 1 | 2798' | | |
| ALL INTERNATIONAL AIRLINES | | | JOINT USE | 2 | 213763' | | |
| CITY & COUNTY OF SAN FRANCISCO | | | JOINT USE | 4 | 6575' | | |
| AIRPORTS COMMISSION | | | | | | | |
| SAN FRANCISCO INTERNATIONAL AIRPORT | | | | | | | |
| DWG: IT2JT | | | | | | | |
| SCALE: 1"=100'-0" | | | | | | | |
| DATE: 07/01/2010 | | | | | | | |

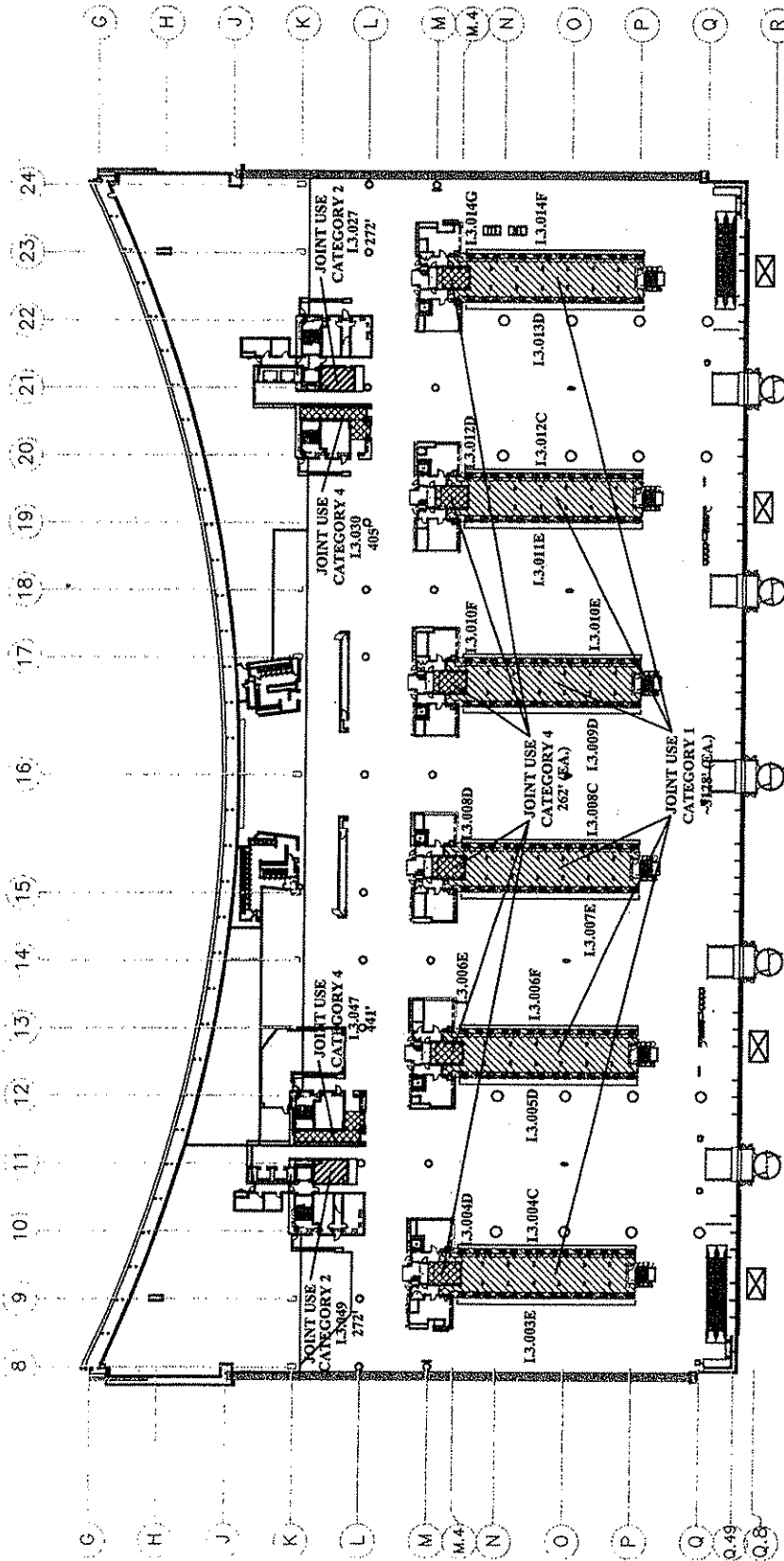

| TENANT LOCATION LEASE DRAWING | | LOCATION | TENANT | CAT | AREA | CONTRACT | EFF DATE |
|--|--|----------|-----------|-----|--------|----------|----------|
| LOCATION: INTERNATIONAL TERMINAL, 3RD FLOOR CENTER | | | JOINT USE | 1 | 18769' | | |
| ALL INTERNATIONAL AIRLINES | | | JOINT USE | 2 | 544' | | |
| CITY & COUNTY OF SAN FRANCISCO | | | JOINT USE | 4 | 2418' | | |
| AIRPORTS COMMISSION | | | | | | | |
| SAN FRANCISCO INTERNATIONAL AIRPORT | | | | | | | |
| DWG: IT3JT | | | | | | | |
| SCALE: 1/8"=1'-0" | | | | | | | |
| DATE: 07/01/2010 | | | | | | | |

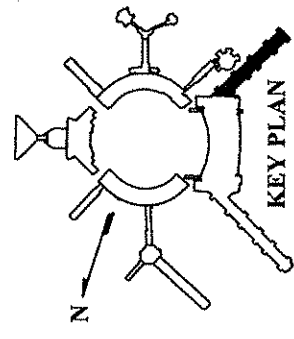
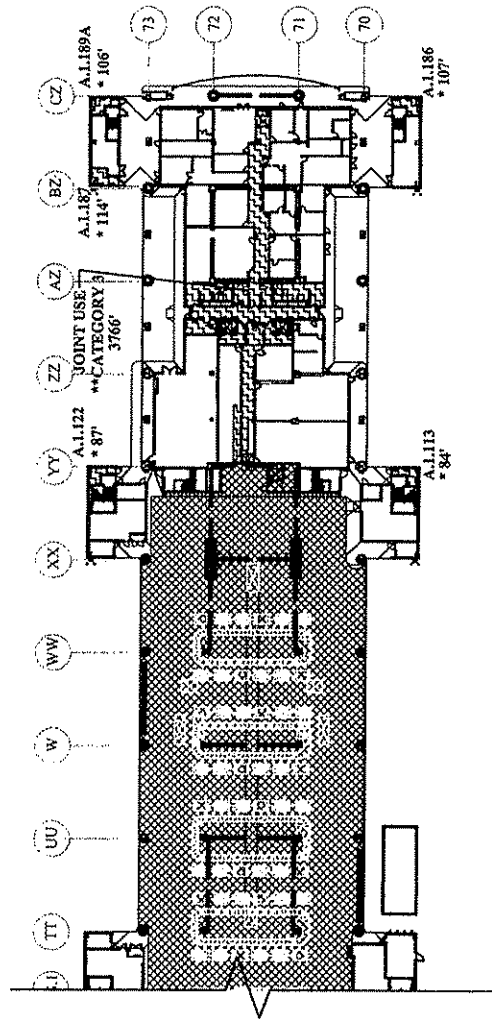
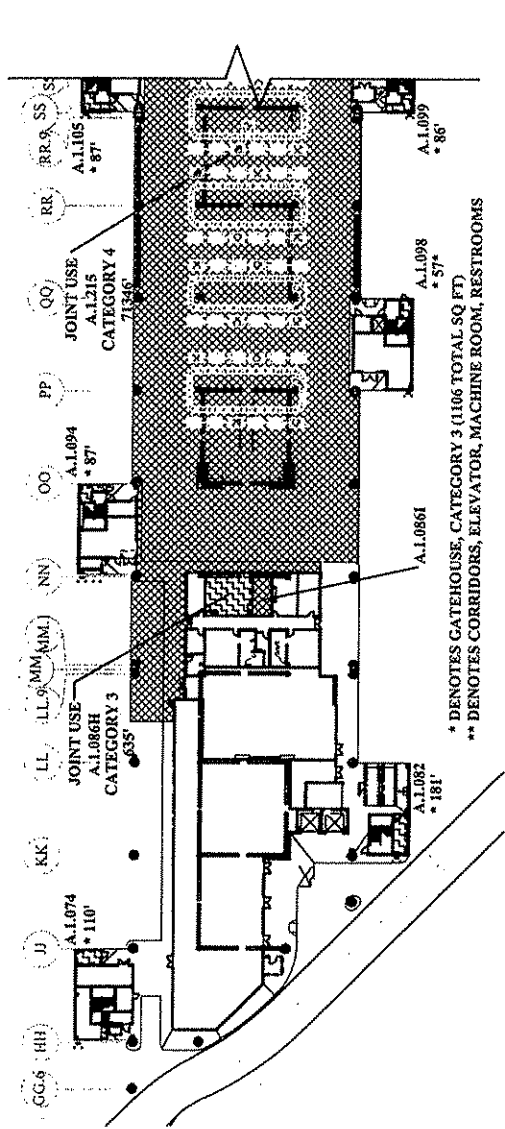

TENANT LOCATION LEASE DRAWING

LOCATION: BOARDING AREA A, 1ST FLOOR

ALL INTERNATIONAL AIRLINES

CITY & COUNTY OF SAN FRANCISCO

AIRPORTS COMMISSION

SAN FRANCISCO INTERNATIONAL AIRPORT

| LOCATION | TENANT | CAT | AREA | CONTRACT | EFF DATE |
|----------|-------------|-----|--------|----------|----------|
| | JT CORRIDOR | 3 | 4401' | | |
| | JT GATEHSE | 3 | 1106' | | |
| | JOINT USE | 4 | 71346' | | |
| | | | | | |
| | | | | | |
| | | | | | |

DWG: BAAIJT

SCALE: 1/16"=0"

DATE: 07/01/2010

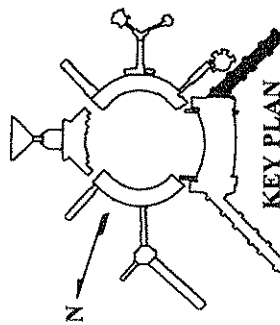
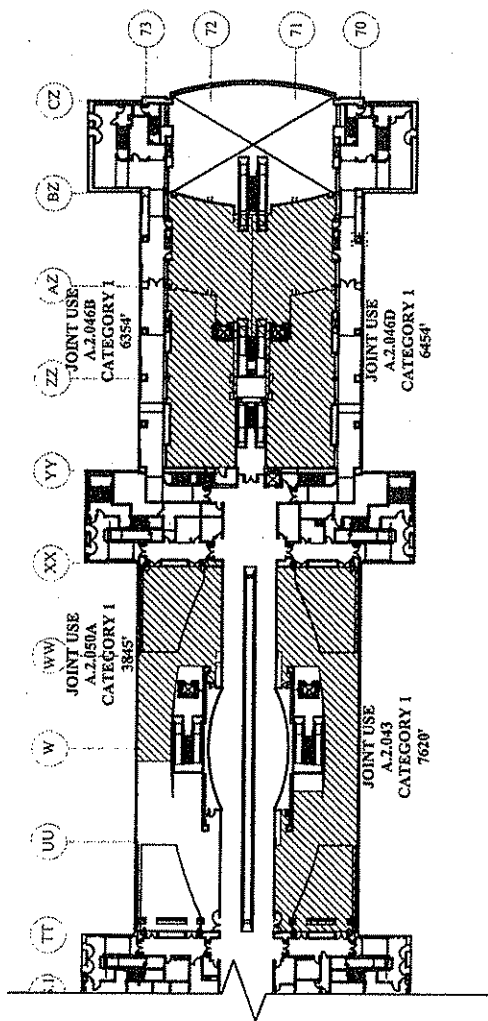
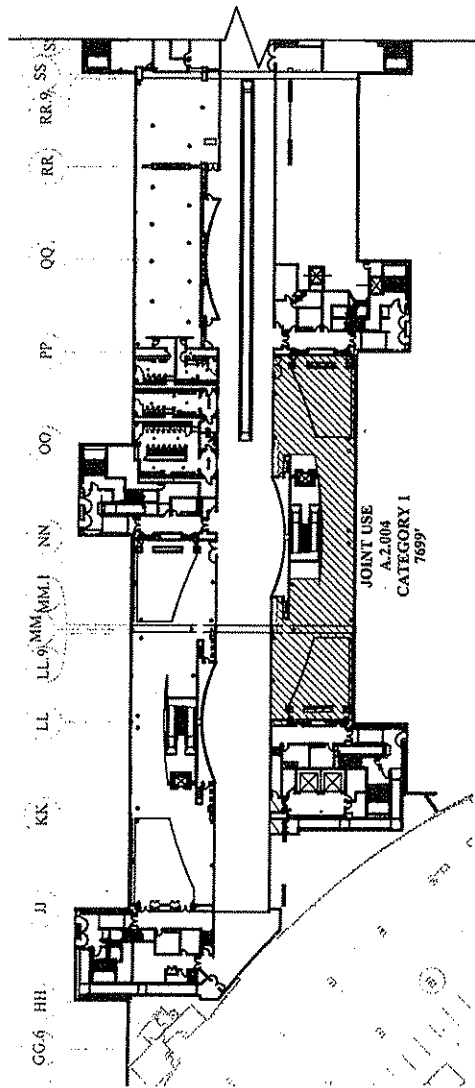

| TENANT LOCATION LEASE DRAWING | | LOCATION | TENANT | CAT | AREA | CONTRACT | EFF DATE |
|--------------------------------------|--|----------|-----------|-----|--------|----------|----------|
| LOCATION: BOARDING AREA A, 2ND FLOOR | | | JOINT USE | 1 | 31972' | | |
| ALL INTERNATIONAL AIRLINES | | | | | | | |
| CITY & COUNTY OF SAN FRANCISCO | | | | | | | |
| AIRPORTS COMMISSION | | | | | | | |
| SAN FRANCISCO INTERNATIONAL AIRPORT | | | | | | | |
| DWG: BAA2JT | | | | | | | |
| SCALE: 1/4"=1'-0" | | | | | | | |
| DATE: 07/01/2010 | | | | | | | |

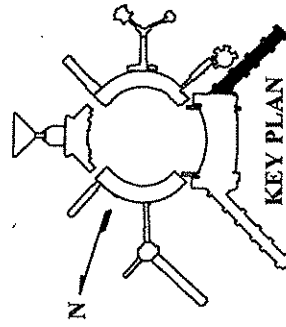
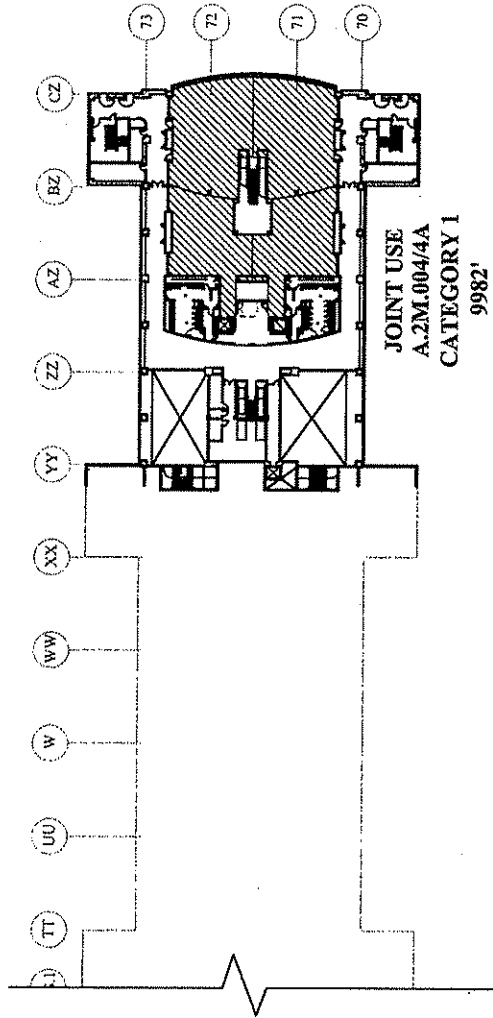
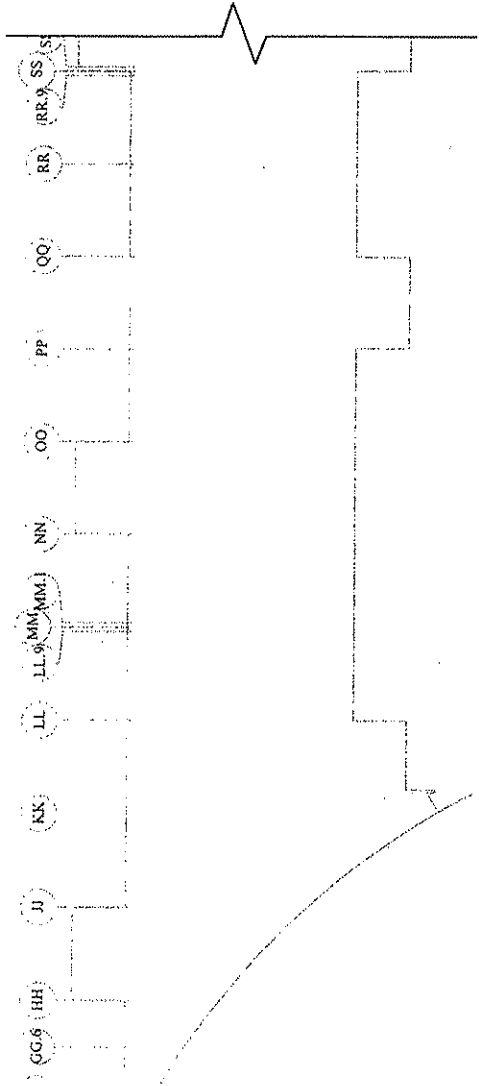

TENANT LOCATION LEASE DRAWING

LOCATION: BOARDING AREA A, 2ND FLOOR MEZZANINE

ALL INTERNATIONAL AIRLINES

CITY & COUNTY OF SAN FRANCISCO

AIRPORTS COMMISSION

SAN FRANCISCO INTERNATIONAL AIRPORT

DWG: BAA2MJT

SCALE: 1/8"=1'-0"

DATE: 07/01/2010

| TENANT | LOCATION | JOINT USE | CAT | AREA | CONTRACT | EFF DATE |
|--------|----------|-----------|-----|-------|----------|----------|
| | | JOINT USE | 1 | 9982' | | |
| | | | | | | |
| | | | | | | |
| | | | | | | |
| | | | | | | |

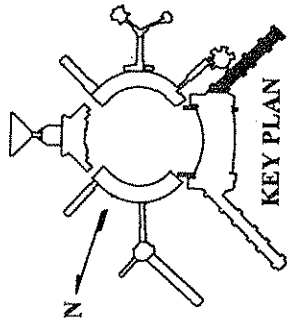
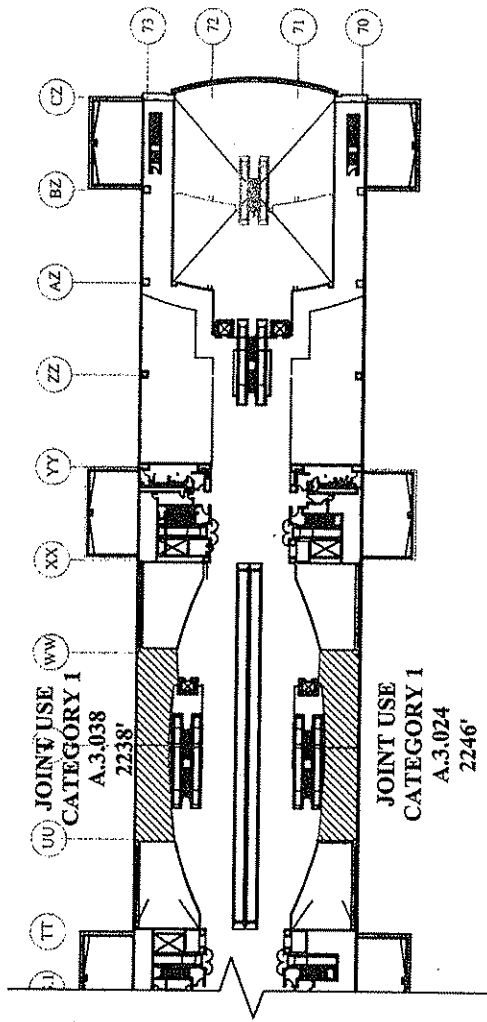
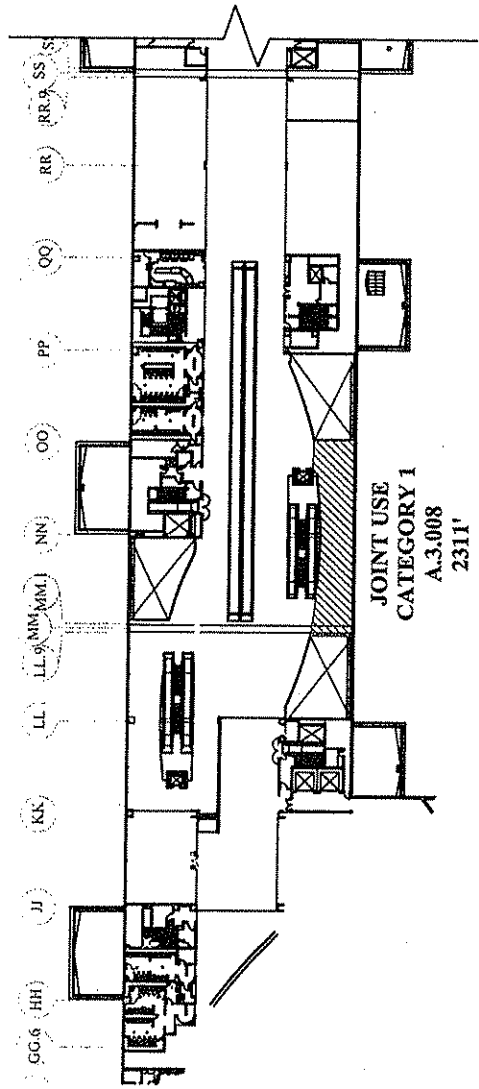

| TENANT LOCATION LEASE DRAWING | | LOCATION | TENANT | CAT | AREA | CONTRACT | EFF DATE |
|--------------------------------------|--|----------|-----------|-----|-------|----------|----------|
| LOCATION: BOARDING AREA A, 3RD FLOOR | | | JOINT USE | 1 | 6795' | | |
| ALL INTERNATIONAL AIRLINES | | | | | | | |
| CITY & COUNTY OF SAN FRANCISCO | | | | | | | |
| AIRPORTS COMMISSION | | | | | | | |
| SAN FRANCISCO INTERNATIONAL AIRPORT | | | | | | | |
| DWG: BAA3JT | | | | | | | |
| SCALE: 1/8"=0'-0" | | | | | | | |
| DATE: 07/01/2010 | | | | | | | |

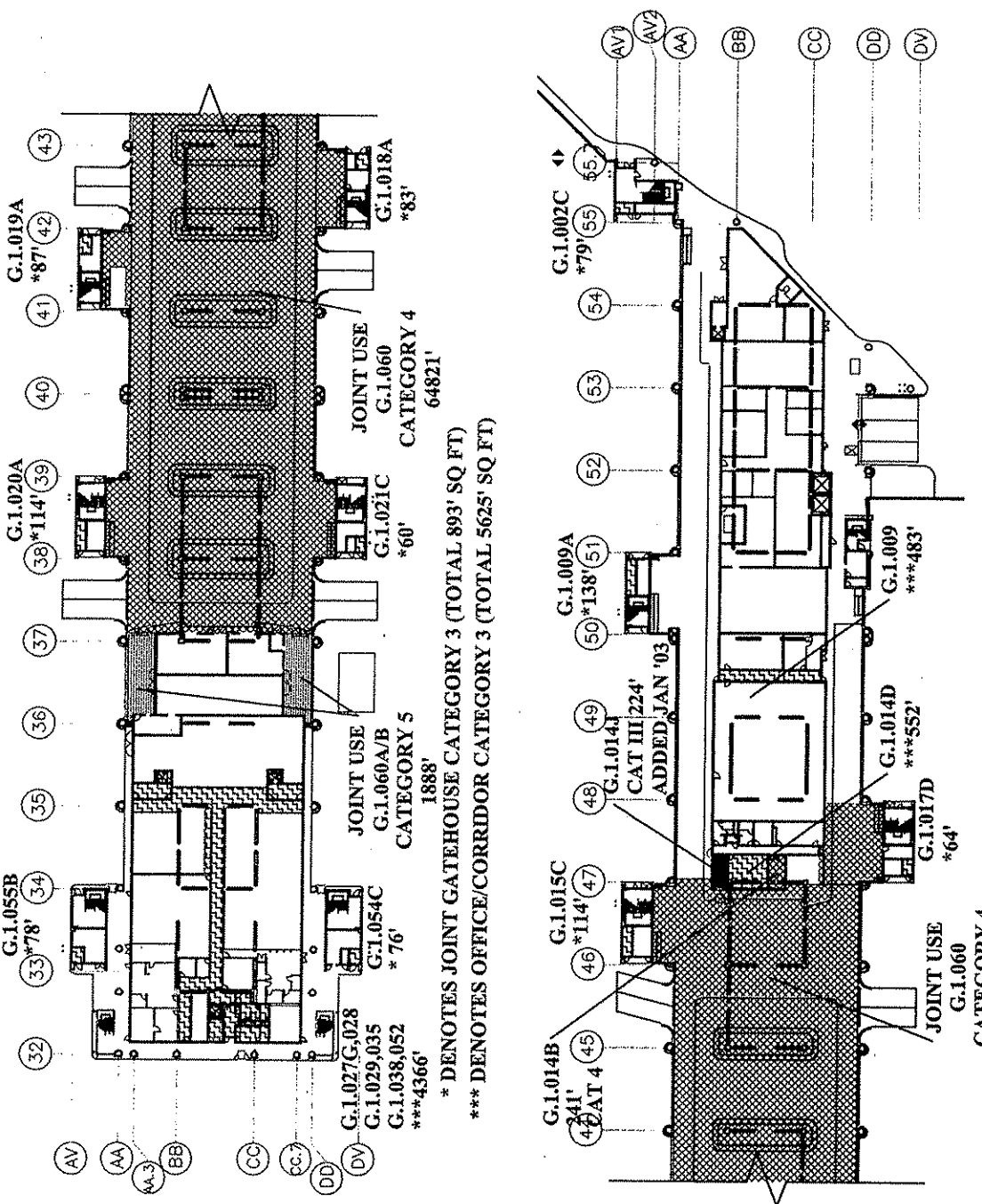

* DENOTES JOINT GATEHOUSE CATEGORY 3 (TOTAL 893' SQ FT)
 *** DENOTES OFFICE/CORRIDOR CATEGORY 3 (TOTAL 5625' SQ FT)

TENANT LOCATION LEASE DRAWING

| LOCATION | TENANT | CAT | AREA | CONTRACT | EFF DATE |
|--|-------------|-----|--------|----------|----------|
| BOARDING AREA G, 1ST FLOOR ALL INTERNATIONAL AIRLINES CITY & COUNTY OF SAN FRANCISCO AIRPORTS COMMISSION SAN FRANCISCO INTERNATIONAL AIRPORT | JT GATEHOUS | 3 | 893' | | |
| | OFFICE/COR | 3 | 5625' | | |
| | JOINT USE | 4 | 65062' | | |
| | JOINT USE | 5 | 1888' | | |
| | | | | | |

DWG: BAGLJT
 SCALE: 1/8"=0'
 DATE: 07/01/2010

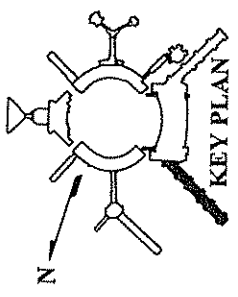
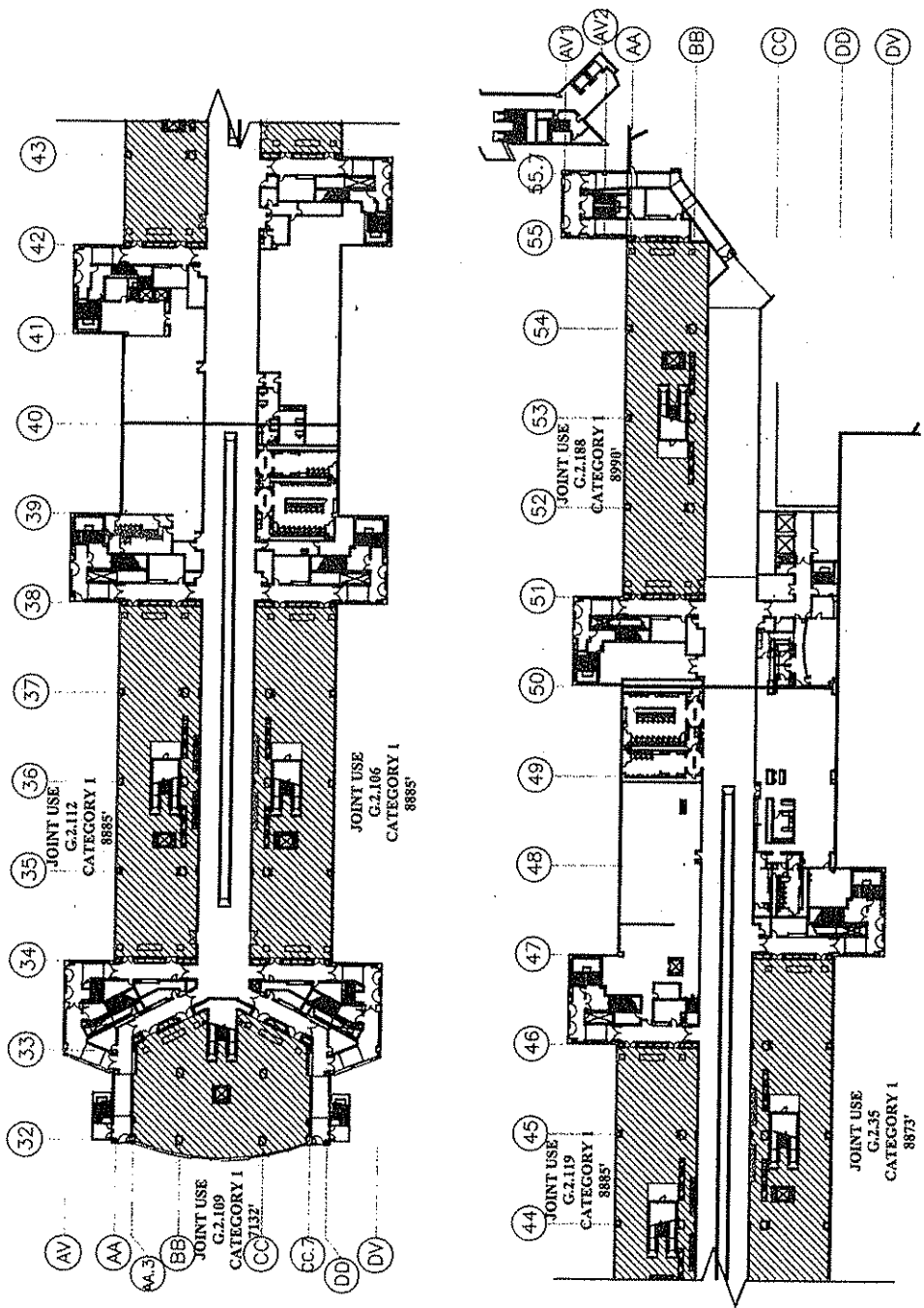

TENANT LOCATION LEASE DRAWING

| | | | | | | |
|--------------------------------------|--|-----------|-----|--------|----------|----------|
| LOCATION: BOARDING AREA G, 2ND FLOOR | | TENANT | CAT | AREA | CONTRACT | EFF DATE |
| ALL INTERNATIONAL AIRLINES | | JOINT USE | 1 | 51650' | | |
| CITY & COUNTY OF SAN FRANCISCO | | | | | | |
| AIRPORTS COMMISSION | | | | | | |
| SAN FRANCISCO INTERNATIONAL AIRPORT | | | | | | |
| DWG: BAG2JT | | | | | | |
| SCALE: 1/8"=0'-0" | | | | | | |
| DATE: 07/01/2010 | | | | | | |

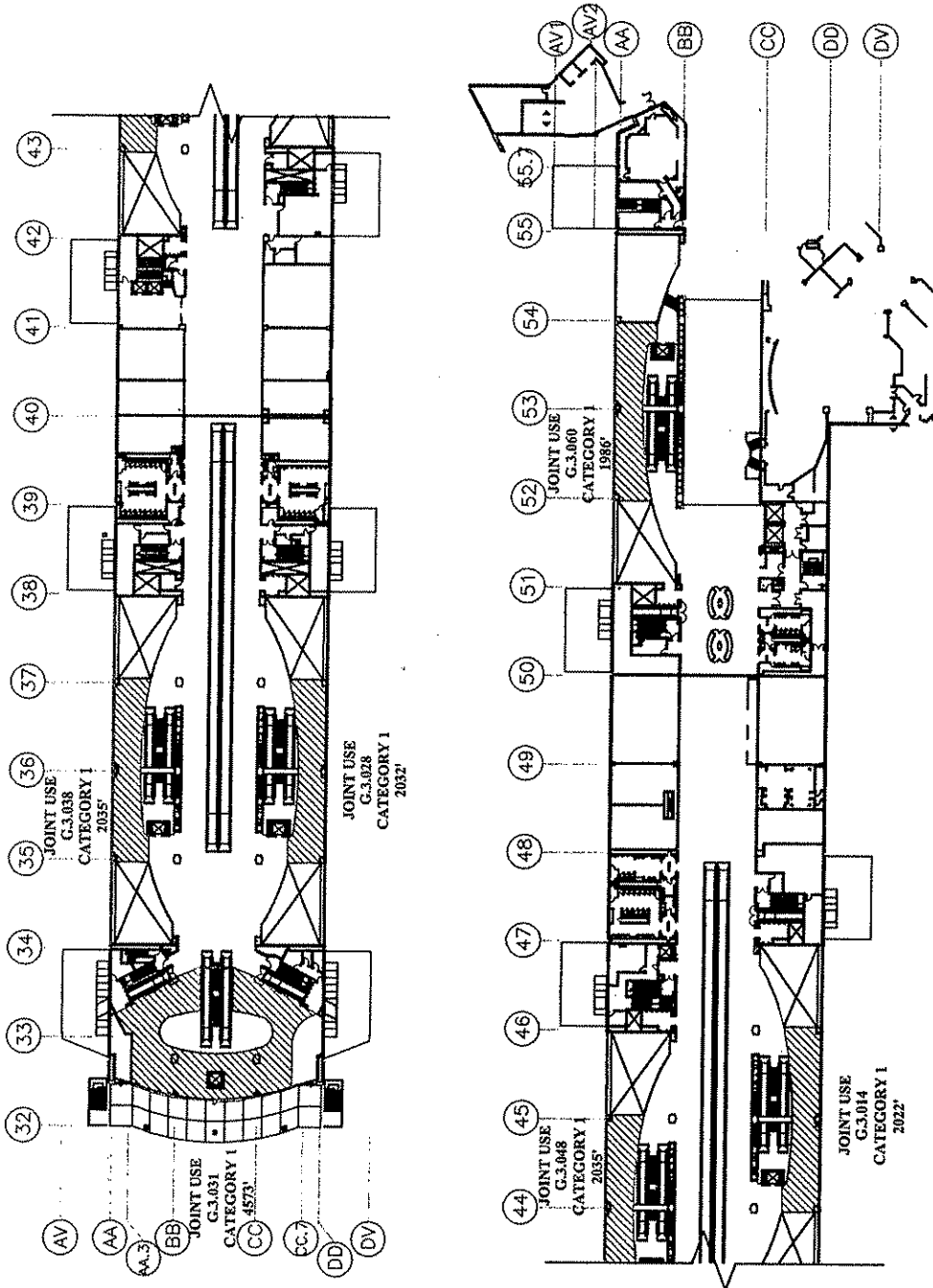

TENANT LOCATION LEASE DRAWING

LOCATION: BOARDING AREA G, 3RD FLOOR
 ALL INTERNATIONAL AIRLINES
 CITY & COUNTY OF SAN FRANCISCO
 AIRPORTS COMMISSION
 SAN FRANCISCO INTERNATIONAL AIRPORT

| LOCATION | TENANT | CAT | AREA | CONTRACT | EFF DATE |
|----------|-----------|-----|--------|----------|----------|
| | JOINT USE | 1 | 14683' | | |
| | | | | | |
| | | | | | |
| | | | | | |
| | | | | | |
| | | | | | |

DWG: BAG3JT
 SCALE: 1/8"=1'-0"
 DATE: 07/01/2010

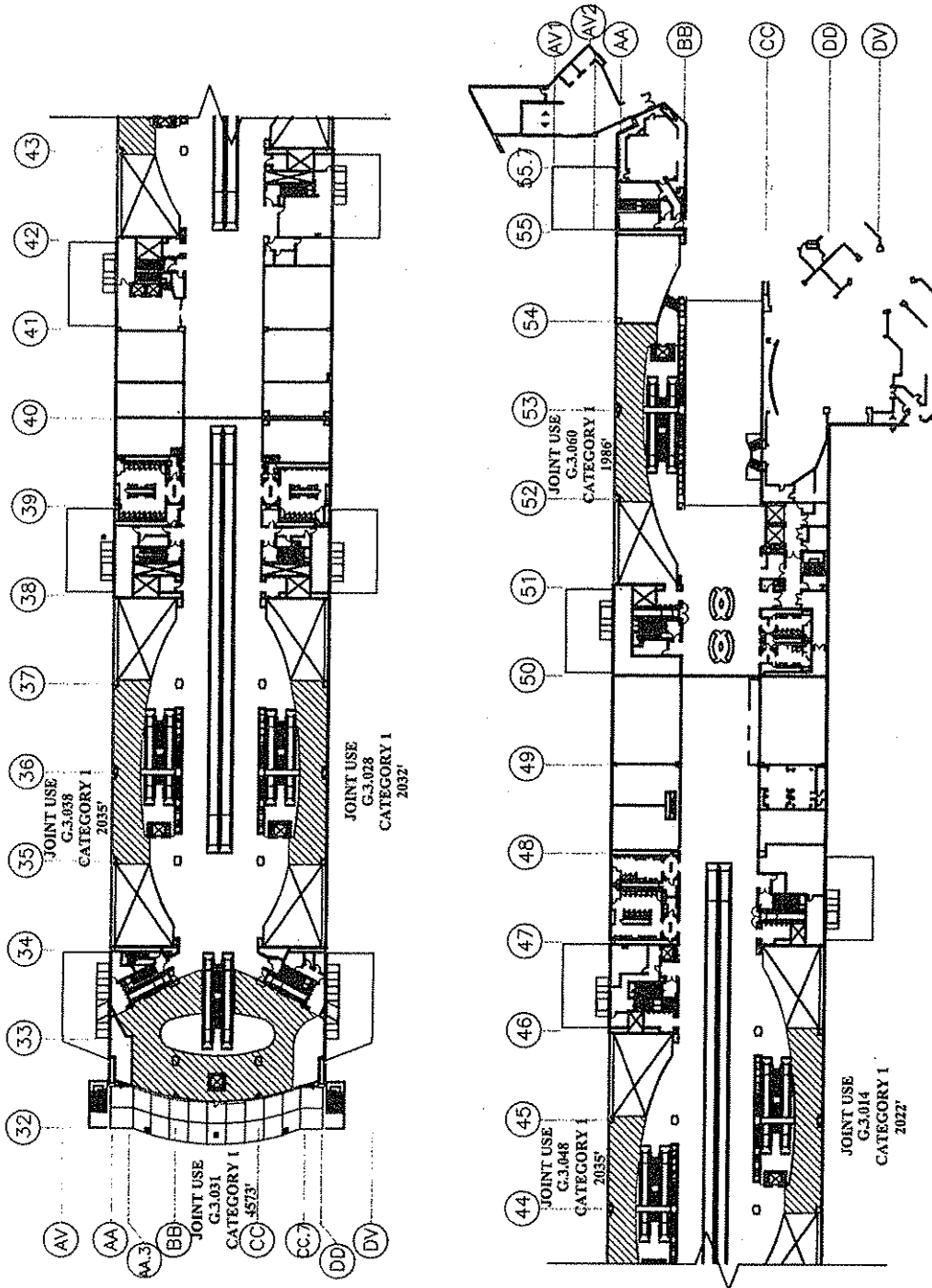

TENANT LOCATION LEASE DRAWING

LOCATION: BOARDING AREA G, 3RD FLOOR
 ALL INTERNATIONAL AIRLINES
 CITY & COUNTY OF SAN FRANCISCO
 AIRPORTS COMMISSION
 SAN FRANCISCO INTERNATIONAL AIRPORT

| LOCATION | TENANT | CAT | AREA | CONTRACT | EFF DATE |
|----------|-----------|-----|--------|----------|----------|
| | JOINT USE | 1 | 14683' | | |
| | | | | | |
| | | | | | |
| | | | | | |
| | | | | | |
| | | | | | |

DWG: BAG3JT
 SCALE: 1/8"=1'-0"
 DATE: 07/01/2010

MODIFICATION NO. 5 TO
AIRLINE – AIRPORT LEASE AND USE AGREEMENT
SAN FRANCISCO INTERNATIONAL AIRPORT

Continental Airlines, Inc.

THIS MODIFICATION OF AGREEMENT (this “**Modification**”) dated as of July 1, 2010, is entered into by and between the City and County of San Francisco, acting by and through its Airport Commission (“**City**”), and Continental Airlines, Inc., (“**Airline**”).

Recitals

- A. The City and County of San Francisco owns San Francisco International Airport (the “**Airport**”) located in the County of San Mateo, State of California, which Airport is operated by and through the Airport Commission, the chief executive officer of which is the Airport Director.
- B. Pursuant to that certain Airline-Airport Lease and Use Agreement L-82-0316, dated as of July 1, 1981, Airline leases from City certain premises located at the Airport. Such Lease and Use Agreement has been modified and amended previously pursuant to the modifications and amendments listed on the attached *Appendix A*. As used below, the term “**Agreement**” shall mean the Lease and Use Agreement, as amended and modified by the agreements described on *Appendix A* and this Modification.
- C. The Agreement expires on June 30, 2011 and the City is currently negotiating a new Lease and Use Agreement with the airlines operating at the Airport, which agreement will be effective July 1, 2011 and have a term of ten (10) years.
- D. In consideration for execution of the new Lease and Use Agreement on or before February 26, 2010, the City has agreed to allow the airlines to relinquish a portion of their respective leasehold space on or after July 1, 2010 (the “**Reduction Date**”).
- E. Airline has executed the new Lease and Use Agreement and is therefore eligible to relinquish a portion of the Demised Premises of the Agreement pursuant to this Modification.
- F. Airline and City now desire to modify the terms of the Agreement to reflect such relinquishment of leasehold space.
- G. Pursuant to the Commission Resolution, the Airport Commission has determined that entering into this Modification is in the best interest of City, and has authorized execution of this Modification. Pursuant to the Board Resolution, the City’s Board of Supervisors has authorized the execution of the Modification.

NOW THEREFORE, in consideration of the foregoing and of the mutual covenants set forth herein, and other good and valuable consideration, receipt of which is hereby acknowledged, the parties do mutually agree as follows:

1. Effective Date; Defined Terms.

(a) The effective date (the “**Effective Date**”) of this Modification shall be the date on which all of the following conditions are satisfied: (1) the Airport Commission and Board of Supervisors shall have approved this Modification; (2) both parties have executed this Modification, (3) Airline has returned possession of the relinquished space(s) to City and City has accepted such possession.

Actual Date: _____ (to be inserted upon determination)

(b) The “**Reduction Date**” of the relinquished space shall be the date on which Airline has surrendered the space, as determined by the City. On or before the Reduction Date, Airline shall surrender the relinquished space(s) in the condition required by the Agreement. Without limiting the generality of the foregoing, Airline shall remove all movable furniture and trade fixtures.

(c) Capitalized terms not defined herein shall have the meanings given them in the Agreement.

2. Airline’s Terminal 1 Exclusive Use Space, as defined in the Agreement, including in Section 203 and Exhibit F, is modified as follows:

(a) 441 square feet of Category I space in Terminal 1 is deleted as described on Airport Drawing No. ST-6-014, Exhibit F-90-R8.

(b) 3,704 square feet of Category II space in Terminal 1 is deleted, as described on Airport Drawings No. ST-6-0-014, Exhibit F-90-R8, and Drawing No. ST-4-007, Exhibit F-87-R6.

(c) 2,707 square feet of Category III space in Terminal 1 is deleted, as described on Airport Drawings No. ST 13.018, Exhibit F-104.

(d) 3,910 square feet of Category IV space relating to EDS Space in Terminal 1 is deleted as described on Airport Drawing No. ST-4-007, Exhibit F-87-R6.

(e) For the purpose of the Modification, all *Exhibits* to the Agreement relating to Exclusive Use Space in Terminal 1 are deleted in their entirety and substituted with *Drawing Numbers T11BABCO, T12BABCO, T11CO, T12CO and T13MCO*, dated July 1, 2010.

(f) As modified hereby, Airline’s Exclusive Use Space in Terminal 1 comprises the following areas, all as shown on *Drawing Numbers: T11BABCO, T12BABCO, T11CO, T12CO and T13MCO*, dated July 1, 2010, attached hereto:

Terminal 1

| Cat. | Square Feet |
|------|-------------|
| I | 8,675 |
| II | 12,500 |
| III | 11,139 |
| IV | 7,543 |
| V | 4,949 |

3. Miscellaneous Provisions. The following provision(s) 3.1 through 3.10 shall be added to the Agreement:

3.1 Tropical Hardwoods and Virgin Redwoods. The City urges companies not to import, purchase, obtain or use for any purpose any tropical hardwood, tropical hardwood wood product, virgin redwood or virgin redwood wood product. Except as expressly permitted by the application of Sections 802(B) and 803(B) of the San Francisco Environment Code, Airline shall not provide any items to the construction of Airline tenant improvements or the Alterations, or otherwise in the performance of this Agreement, which are tropical hardwoods, tropical hardwood wood products, virgin redwood, or virgin redwood wood products. In the event Airline fails to comply in good faith with any of the provisions of Chapter 8 of the San Francisco Environment Code, Airline shall be liable for liquidated damages for each violation in any amount equal to Airline's net profit on the contract, or five percent (5%) of the total amount of the contract dollars, whichever is greater.

3.2 Pesticide Prohibition.

(a) Airline shall comply with the provisions of Section 308 of Chapter 3 of the San Francisco Environment Code (the "Pesticide Ordinance") which (i) prohibit the use of certain pesticides on City property, (ii) require the posting of certain notices and the maintenance of certain records regarding pesticide usage, and (iii) require Airline to submit to the Airport an integrated pest management ("IPM") plan that (a) lists, to the extent reasonably possible, the types and estimated quantities of pesticides that Airline may need to apply to the Demised Premises during the terms of this Agreement, (b) describes the steps Airline will take to meet the City's IPM Policy described in Section 300 of the Pesticide Ordinance, and (c) identifies, by name, title, address, and telephone number, an individual to act as the Airline's primary IPM contact person with the City. In addition, Airline shall comply with the requirements of Sections 303(a) and 303(b) of the Pesticide Ordinance.

(b) Nothing herein shall prevent Airline, through the Director, from seeking a determination from the Commission on the Environment that it is exempt from complying with certain portions of the Pesticide Ordinance as provided in Section 307 thereof.

3.3 MacBride Principles - Northern Ireland. The City urges companies doing business in Northern Ireland to move toward resolving employment inequities and encourages them to abide by the MacBride Principles as expressed in San Francisco Administrative Code Section 12F.1 et seq. The City also urges San Francisco companies to do business with corporations that abide by the MacBride Principles. Airline acknowledges that it has read and understands the above statement of the City concerning doing business in Northern Ireland.

3.4 No Advertising or Promotions; Prohibition of Tobacco Advertising. Airline shall have no right to conduct any advertising or promotional activities on the Airport. Airline acknowledges and agrees that no advertising of cigarettes or tobacco products is allowed on any real property owned by or under the control of the City, including the Demised Premises and the Airport. This prohibition includes the placement of the name of a company producing, selling or distributing cigarettes or tobacco products or the name of any cigarette or tobacco product in any promotion of any event or product. This prohibition does not apply to any advertisement sponsored by a state, local or nonprofit entity designed to communicate the health hazards of cigarettes and tobacco products or to encourage people not to smoke or to stop smoking.

3.5 First Source Hiring Ordinance. The City has adopted a First Source Hiring Ordinance (Board of Supervisors Ordinance No. 264 -98) which establishes specific requirements, procedures and monitoring for first source hiring of qualified, economically disadvantaged individuals for entry level positions. Within thirty (30) days after the Real Estate Division of the Department of Administrative

Services adopts a First Source Hiring Implementation and Monitoring Plan in accordance with the First Source Hiring Ordinance, Airline shall enter into a First Source Hiring Agreement that meets the applicable requirements of Section 83.9 of the First Source Hiring Ordinance.

3.6 Compliance with Laws. Airline shall keep itself fully informed of the City Charter, codes, ordinances and regulations of the City and of all State, and federal laws in any manner applicable to the performance of this Agreement, and must at all times comply with such applicable local codes, ordinances, and regulations and all applicable laws as they may be amended from time to time.

3.7 Airport Intellectual Property. Pursuant to Resolution No. 01-0118, adopted by the Airport Commission on April 18, 2001, the Airport Commission affirmed that it will not tolerate the unauthorized use of its intellectual property, including the SFO logo, CADD designs, and copyrighted publications. All proposers, bidders, contractors, tenants, permittees, and others doing business with or at the Airport (including subcontractors and subtenants) may not use the Airport intellectual property, or any intellectual property confusingly similar to the Airport intellectual property, with the Airport Director's prior consent.

3.8 Food Service Waste Reduction. If and to the extent applicable, the Airline agrees to comply fully with and be bound by all of the applicable provisions of the Food Service Waste Reduction Ordinance, as set forth in the San Francisco Environment Code, Chapter 16, including the remedies provided therein, and implementing guidelines and rules. The provisions of Chapter 16 are incorporated herein by reference and made a part of this Agreement as though fully set forth herein. Accordingly, Airline acknowledges that City contractors and lessees may not use Disposable Food Service Ware that contains Polystyrene Foam in City Facilities and while performing under a City contract or lease, and shall instead use suitable Biodegradable/Compostable or Recyclable Disposable Food Service Ware. This provision is a material term of this Agreement. By entering into this agreement, Airline agrees that if it breaches this provision, City will suffer actual damages that will be impractical or extremely difficult to determine; further, Airline agrees that the sum of one hundred dollars (\$100.00) liquidated damages for the first breach, two hundred dollars (\$200.00) liquidated damages for the second breach in the same year, and five hundred dollars (\$500.00) liquidated damages for subsequent breaches in the same year is a reasonable estimate of the damage that City will incur based on the violation, established in light of the circumstances existing at the time this agreement was made. Such amounts shall not be considered a penalty, but rather agreed monetary damages sustained by City because of Airline's failure to comply with this provision.

3.9 Labor Disputes. Airline agrees to use commercially reasonable efforts to avoid disruption to City, other Air Carriers, Airport tenants, or members of the public arising from labor disputes involving Airline, and in the event of a strike, picketing, demonstration or other labor difficulty involving Airline, to use commercially reasonable efforts, including the utilization of available legal remedies, to minimize or eliminate any disruption to City, other Air Carriers, Airport tenants, or members of the public, arising from such strike, picketing, demonstration or other labor difficulty.

3.10 Preservative-Treated Wood Containing Arsenic. As of July 1, 2003, Airline may not purchase preservative-treated wood products containing arsenic in the performance of this Agreement unless an exemption from the requirements of Environment Code Chapter 13 is obtained from the Department of Environment under Section 1304 of the Environment Code. The term "preservative-treated wood containing arsenic" shall mean wood treated with a preservative that contains arsenic, elemental arsenic, or an arsenic copper combination, including, but not limited to, chromated copper arsenate preservative, ammoniac copper zinc arsenate preservative, or ammoniacal copper arsenate preservative. Airline may purchase preservative-treated wood products on the list of environmentally preferable alternatives prepared and adopted by the Department of Environment. This provision does not preclude Airline from purchasing preservative-treated wood containing arsenic for saltwater immersion.

The term "saltwater immersion" shall mean a pressure-treated wood that is used for construction purposes or facilities that are partially or totally immersed in saltwater.

4. **Modification.** As modified hereby, the Agreement remains in full force and effect.

X:\TENANTS\AIRLINES\LEASES\2010 Lease Modifications\2010 Lease Mod L&U - Continental Airlines Mod#5.DOC

IN WITNESS WHEREOF, the parties hereto have executed this Modification as of the date first written above.

AIRLINE: Continental Airlines, Inc.,
a Delaware corporation

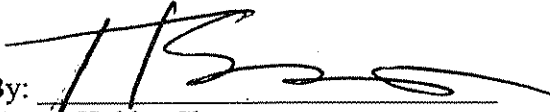
By: 
Name: Holden Shannon
Title: Senior Vice President
System Operations and Real Estate

By: _____
Name: _____
Title: _____

CITY: CITY AND COUNTY OF SAN FRANCISCO,
a municipal corporation,
acting by and through its Airport Commission

John L. Martin
Airport Director

AUTHORIZED BY AIRPORT
COMMISSION

Resolution No. _____

Adopted: _____

Attest: _____

Secretary
Airport Commission

Approved by Board of Supervisors on
_____, pursuant to Resolution
No. _____

APPROVED AS TO FORM:
DENNIS J. HERRERA,
City Attorney

By _____
Deputy City Attorney

APPENDIX A

MODIFICATIONS TO LEASE AND USE AGREEMENT

CONTINENTAL AIRLINES, INC.

| <u>Modification</u> | <u>Date</u> | <u>Resolution Number</u> |
|---------------------|-------------|--------------------------|
| | | 82-0316 |
| 1 | 2-19-85 | 85-0054 |
| 2 | 2-21-89 | 89-0043 |
| 3 | 8-17-93 | 93-0167 |
| 4 | 10-18-96 | 96-0270 |

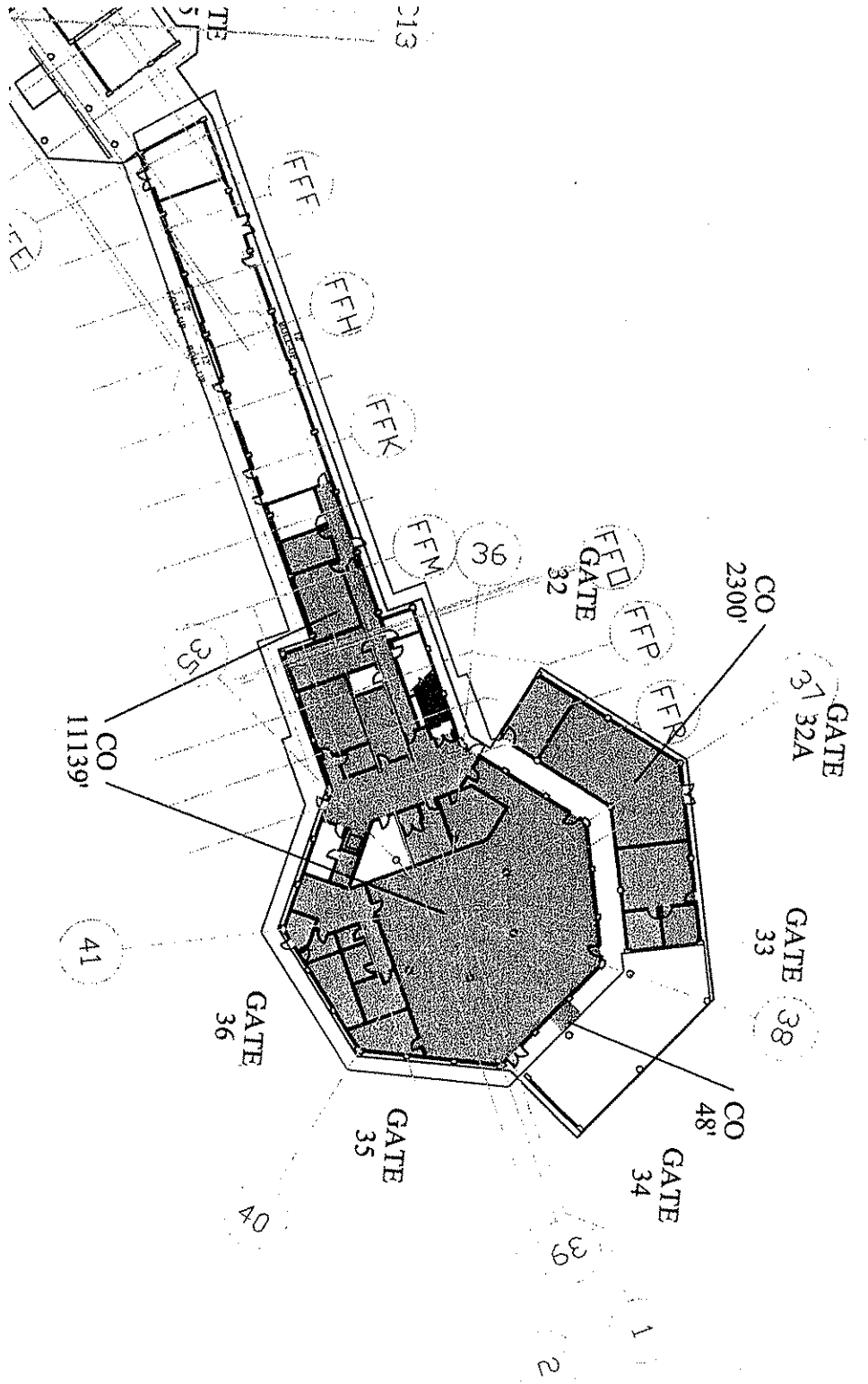
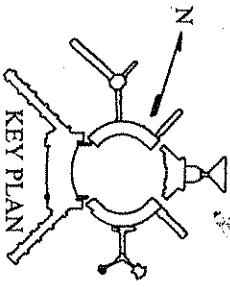

TENANT LOCATION LEASE DRAWING

LOCATION: TERMINAL 1 - BOARDING AREA B, 1ST FLOOR

CONTINENTAL AIRLINES

CITY & COUNTY OF SAN FRANCISCO

AIRPORTS COMMISSION

SAN FRANCISCO INTERNATIONAL AIRPORT

| LOCATION | TENANT | CAT | AREA | CONTRACT | EFF DATE |
|----------|--------|-----|--------|-----------|----------|
| BABI | CO | 3 | 11139' | L-82-0316 | |

BABI

CO

3

11139'

L-82-0316

DWG: T11BABC0

SCALE: 1/8"=1'-0"

DATE: 07/01/2010

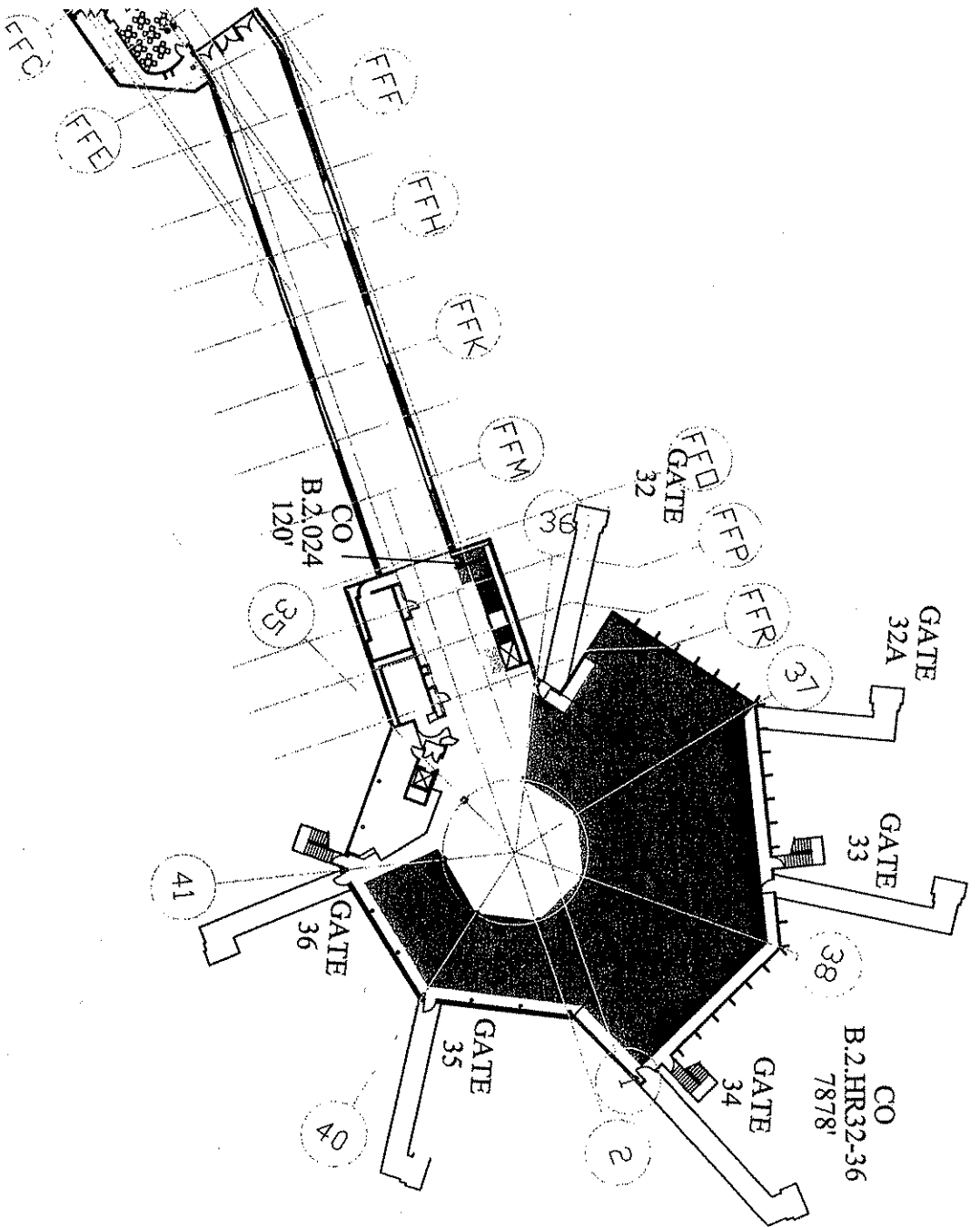
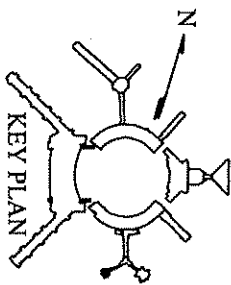

TENANT LOCATION LEASE DRAWING

| LOCATION | TENANT | CAT | AREA | CONTRACT | EFF DATE |
|-------------|--------|-----|-------|----------|----------|
| B.2.024 | CO | 2 | 120' | | |
| B.2.HR32-36 | CO | 1 | 7878' | | |

| | |
|---|-------------------|
| LOCATION: TERMINAL 1, BOARDING AREA B - 2ND FLOOR | |
| CONTINENTAL AIRLINES HOLDROOMS 32 TO 36 | |
| CITY & COUNTY OF SAN FRANCISCO | DWG: T12BABCO |
| AIRPORTS COMMISSION | SCALE: 1/8"=1'-0" |
| SAN FRANCISCO INTERNATIONAL AIRPORT | DATE: 07/01/2010 |

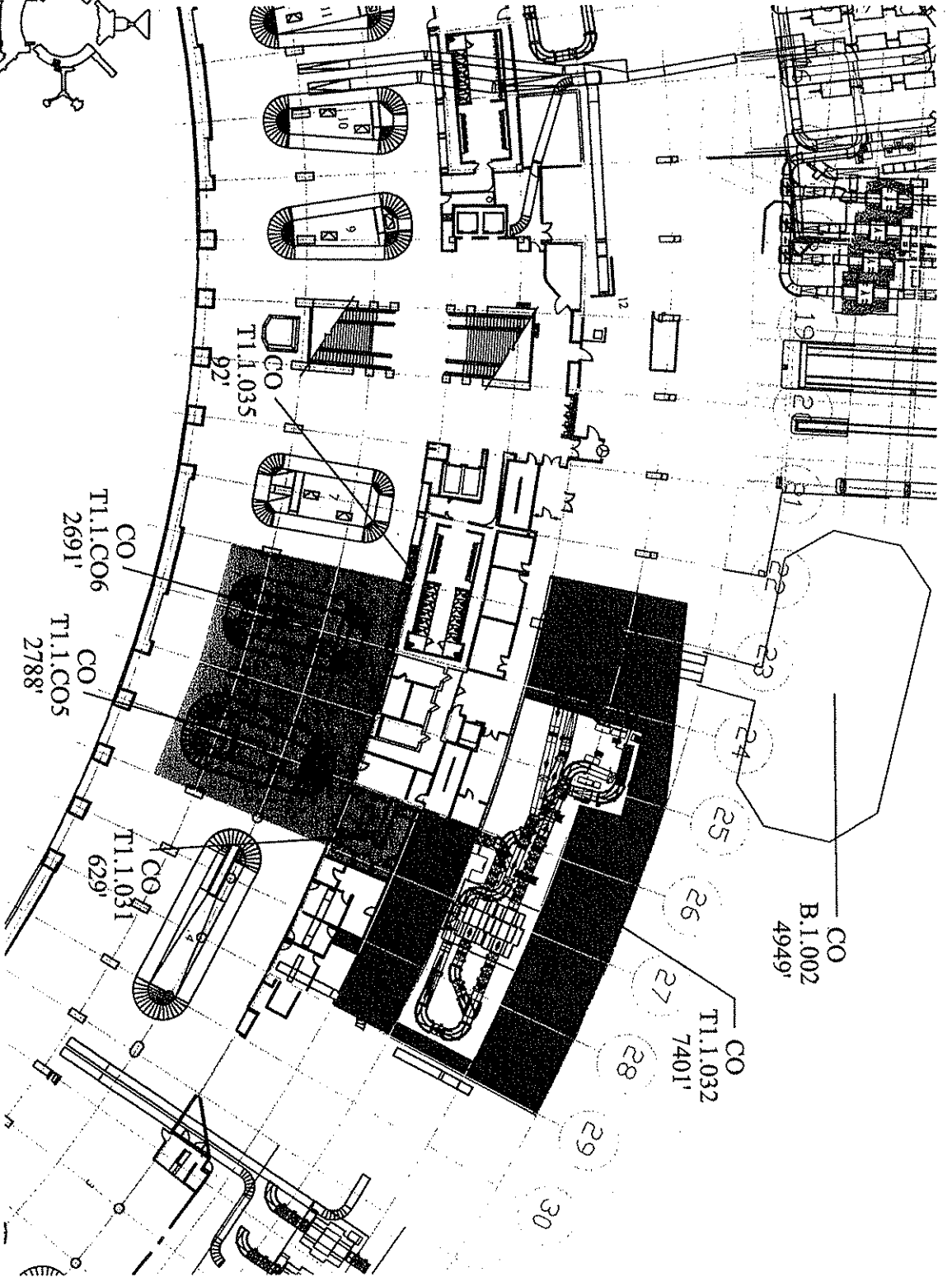
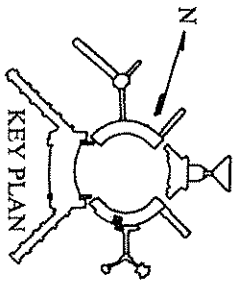

TENANT LOCATION LEASE DRAWING

| LOCATION | TENANT | CAT | AREA | CONTRACT | EFF DATE |
|-------------------------------------|--------|-----|-------|-----------|----------|
| LOCATION: TERMINAL 1 - 2ND FLOOR | | | | | |
| B.1.002 | CO | 5 | 4949' | L-82-0316 | |
| T1.1.031 | CO | 2 | 629' | L-82-0316 | |
| CONTINENTAL AIRLINES | | | | | |
| T1.1.032 | CO | 4 | 7401' | L-82-0316 | |
| CITY & COUNTY OF SAN FRANCISCO | | | | | |
| T1.1.035 | CO | 2 | 92' | L-82-0316 | |
| AIRPORTS COMMISSION | | | | | |
| T1.1.035 | CO | 2 | 2788' | L-82-0316 | |
| SAN FRANCISCO INTERNATIONAL AIRPORT | | | | | |
| T1.1.036 | CO | 2 | 2691' | L-82-0316 | |

DWG: T11CO
SCALE: 1/8"=1'-0"
DATE: 07/01/2010

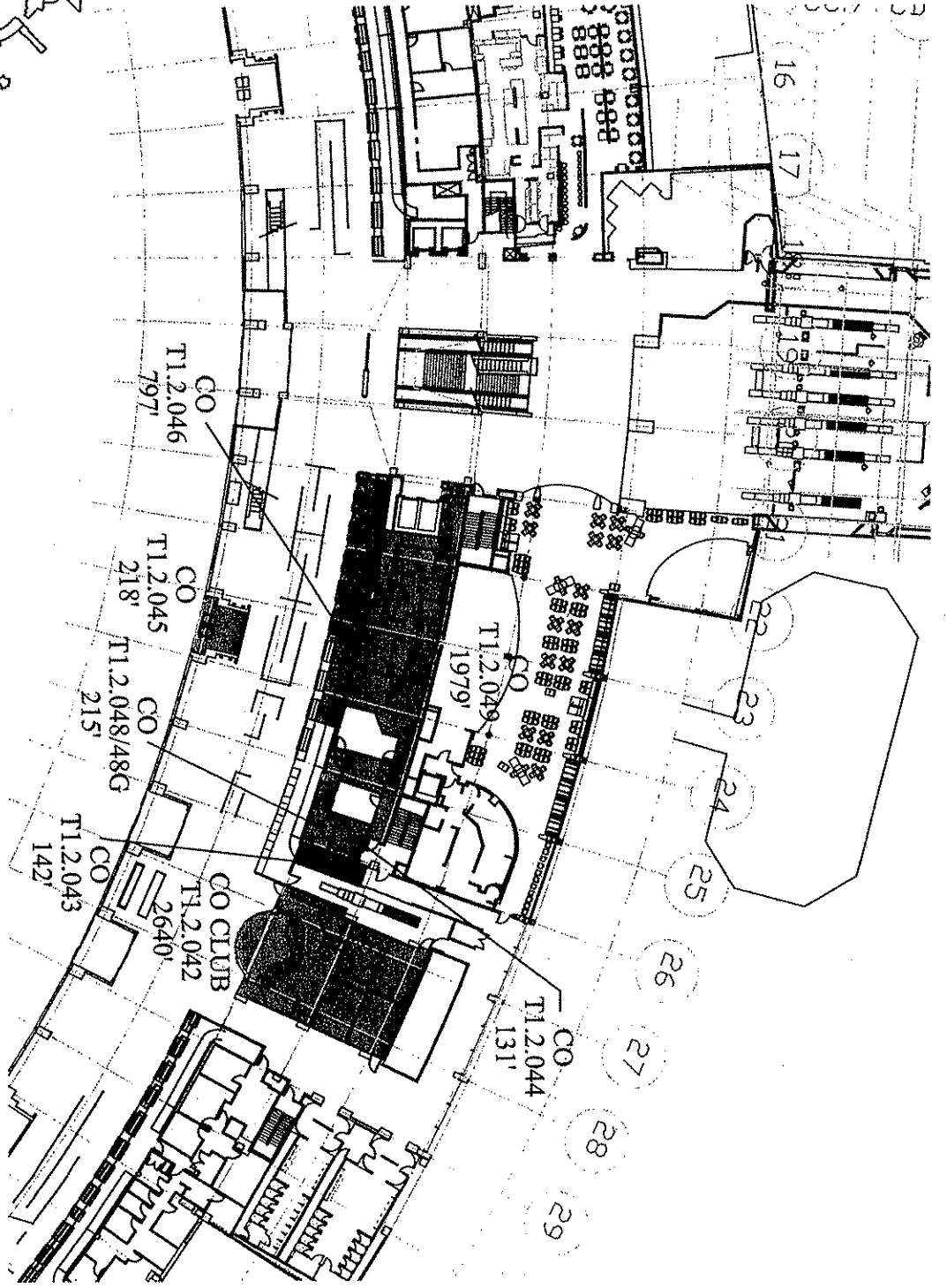
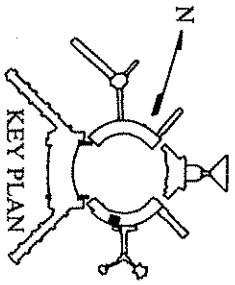

TENANT LOCATION LEASE DRAWING

LOCATION: TERMINAL 1 - 2ND FLOOR
 CONTINENTAL AIRLINES
 CITY & COUNTY OF SAN FRANCISCO
 AIRPORTS COMMISSION
 SAN FRANCISCO INTERNATIONAL AIRPORT

DWG: T12CO
 SCALE: 1/8"=1'-0"
 DATE: 07/01/2010

| LOCATION | TENANT | CAT | AREA | CONTRACT | EFF DATE |
|--------------|--------|-----|-------|----------|----------|
| T1.2.049 | CO | 2 | 1979' | L82-0316 | |
| T1.2.042 | CO | 2 | 2640' | L82-0316 | |
| T1.2.043 | CO | 4 | 142' | L82-0316 | |
| T1.2.044 | CO | 2 | 131' | L82-0316 | |
| T1.2.045 | CO | 2 | 218' | L82-0316 | |
| T1.2.046 | CO | 1 | 797' | L82-0316 | |
| T1.2.048/48G | CO | 2 | 215' | L82-0316 | |

**FORM SFEC-126:
NOTIFICATION OF CONTRACT APPROVAL
(S.F. Campaign and Governmental Conduct Code § 1.126)**

| | |
|---|----------------------------------|
| City Elective Officer Information <i>(Please print clearly.)</i> | |
| Name of City elective officer(s): | City elective office(s) held: |
| ; Members, SF Board of Supervisors | Members, SF Board of Supervisors |

| | |
|--|--|
| Contractor Information <i>(Please print clearly.)</i> | |
| Name of contractor: Continental Airlines, Inc. | |
| <i>Please list the names of (1) members of the contractor's board of directors; (2) the contractor's chief executive officer, chief financial officer and chief operating officer; (3) any person who has an ownership of 20 percent or more in the contractor; (4) any subcontractor listed in the bid or contract; and (5) any political committee sponsored or controlled by the contractor. Use additional pages as necessary.</i> | |
| Board Members: | |
| (1) Kirbyjon H. Caldwell, Carolyn Corvi, Henry L. Meyer III, Oscar Munoz, Laurence E. Simmons, Jeffrey Smisek, Karen Hastie Williams, Ronald B. Woodard, Charles A. Yamarone | |
| (2) Jeffrey Smisek – Chairman, President and CEO; Zane Rowe – Executive VP and Chief Financial Officer; Mark Moran – Executive VP and Chief Operating Officer | |
| (3) Not applicable. | |
| (4) Not applicable. | |
| (5) Not applicable. | |
| Contractor address: 1600 Smith Street, Houston TX 77002 | |
| Date that contract was approved: | Amount of contract: TBD each FY -See attached formula |
| Describe the nature of the contract that was approved: 2011 Airport/Airline Lease and Use Agreement | |
| Comments: | |

This contract was approved by (check applicable):

- the City elective officer(s) identified on this form ()
- a board on which the City elective officer(s) serves San Francisco Board of Supervisors
Print Name of Board
- the board of a state agency (Health Authority, Housing Authority Commission, Industrial Development Authority Board, Parking Authority, Redevelopment Agency Commission, Relocation Appeals Board, Treasure Island Development Authority) on which an appointee of the City elective officer(s) identified on this form sits

Print Name of Board

| | |
|--|---|
| Filer Information <i>(Please print clearly.)</i> | |
| Name of filer: Angela Calvillo, Clerk of the Board | Contact telephone number: () 415-554-5184 |
| Address: 1 Dr. Carlton B Good Pl, Room 244, SF CA 94102 | E-mail: Board.of.Supervisors@sfgov.org |

Signature of City Elective Officer (if submitted by City elective officer)

Date Signed

Signature of Board Secretary or Clerk (if submitted by Board Secretary or Clerk)

Date Signed

FORM SFEC-126:
NOTIFICATION OF CONTRACT APPROVAL
(S.F. Campaign and Governmental Conduct Code § 1.126)

| | |
|---|--|
| City Elective Officer Information <i>(Please print clearly.)</i> | |
| Name of City elective officer(s): | City elective office(s) held: |
| Members, SF Board of Supervisors | Members, SF Board of Supervisors |
| Contractor Information <i>(Please print clearly.)</i> | |
| Name of contractor: Alaska Airlines, Inc. | |
| Please list the names of (1) members of the contractor's board of directors; (2) the contractor's chief executive officer, chief financial officer and chief operating officer; (3) any person who has an ownership of 20 percent or more in the contractor; (4) any subcontractor listed in the bid or contract; and (5) any political committee sponsored or controlled by the contractor. Use additional pages as necessary. | |
| 1 & 2. Board Members, CEO, CFO, COO: Please see attached. | |
| 3. Alaska Air Group, Inc. owns 100% of Alaska Airlines, Inc. | |
| 4. None. | |
| 5. None (assumingly this refers to political committees involved in local or state politics) | |
| Contractor address: 19300 International Blvd., Seattle, WA 98188 (mailing address: P.O. Box 68900, Seattle, WA 98168-0900) | |
| Date that contract was approved: | Amount of contract: TBD each FY--See attached formula |
| Describe the nature of the contract that was approved: 2011 Airport/Airline Lease and Use Agreement | |
| Comments: | |

This contract was approved by (check applicable):

- the City elective officer(s) identified on this form ()
- a board on which the City elective officer(s) serves San Francisco Board of Supervisors
Print Name of Board
- the board of a state agency (Health Authority, Housing Authority Commission, Industrial Development Authority Board, Parking Authority, Redevelopment Agency Commission, Relocation Appeals Board, Treasure Island Development Authority) on which an appointee of the City elective officer(s) identified on this form sits
- _____
- Print Name of Board

| | |
|---|---|
| Filer Information <i>(Please print clearly.)</i> | |
| Name of filer: Angela Calvillo, Clerk of the Board | Contact telephone number: () (415) 554-5184 |
| Address: 1 Dr Carlton B Goodlett Pl Room 244 SF CA 94102 | E-mail: Board.of.Supervisors@sfgov.org |

Signature of City Elective Officer (if submitted by City elective officer)

Date Signed

Signature of Board Secretary or Clerk (if submitted by Board Secretary or Clerk)

Date Signed

ALASKA AIRLINES, INC.**BOARD OF DIRECTORS**

WILLIAM S. AYER
Chair & CEO
Alaska Airlines, Inc.
19300 International Blvd
Seattle, WA 98168

MARK R. HAMILTON
10630 Cutter Circle
Anchorage, AK 99515

DENNIS F. MADSEN
Chair
Pivotlink Software
3213 West Wheeler, No. 373
Seattle, WA 98199

PATRICIA M. BEDIENT
Executive Vice President & CFO
Weyerhaeuser Company
33663 Weyerhaeuser Way So.
Federal Way, WA 98003

JESSIE J. KNIGHT, Jr.
Chair & CEO
San Diego Gas & Electric Company
8330 Century Park Court
San Diego, CA 92123

BYRON I. MALLOTT
Trustee
First Alaskans Institute
102 Cordova St
Juneau, AK 99801

ELECTED OFFICERS

Address: c/o ALASKA AIRLINES, PO BOX 68900, SEATTLE, WA 98168

WILLIAM S. AYER
Chair & Chief Executive Officer
19300 International Blvd
Seattle, WA 98188

JEFFREY M. BUTLER
Vice President/Customer Service –
Airports
19300 International Blvd
Seattle, WA 98188

THOMAS W. NUNN
Vice President/Safety
19300 International Blvd
Seattle, WA 98188

BRADLEY D. TILDEN
President
19300 International Blvd
Seattle, WA 98188

KELLEY J. DOBBS
Vice President/Human Resources and
Labor Relations
19300 International Blvd
Seattle, WA 98188

BRANDON S. PEDERSEN
Vice President/Finance & Chief Financial
Officer
19300 International Blvd
Seattle, WA 98188

BENITO MINICUCCI
Executive Vice President/Operations &
Chief Operating Officer
19300 International Blvd
Seattle, WA 98188

ANDREW R. HARRISON
Vice President/Planning & Revenue
Management
19300 International Blvd
Seattle, WA 98188

JOHN F. SCHAEFER, JR.
Vice President/Finance and Treasurer
19300 International Blvd
Seattle, WA 8188

WILLIAM L. MACKAY
Senior Vice President/Alaska
4750 W. International Airport Road
Anchorage, AK 99502

KRIS M. KUTCHERA
Vice President/Information Technology
20313 28th Avenue South
Seattle, WA 98198

JOSEPH A. SPRAGUE
Vice President/Marketing
19300 International Blvd
Seattle, WA 98188

ANN E. ARDIZZONE
Vice President/Inflight Services
19300 International Blvd
Seattle, WA 98188

KEITH LOVELESS
Vice President/Legal & Corporate Affairs,
General Counsel & Corporate Secretary
19300 International Blvd
Seattle, WA 98188

EDWARD W. WHITE
Vice President/Corporate Real Estate
19300 International Blvd
Seattle, WA 98188

GARY L. BECK
Vice President/Flight Operations
2651 South 192nd
Seattle, WA 98188

FREDERICK L. MOHR
Vice President/Maintenance &
Engineering
Alaska Service Road
Seattle Tacoma International Airport
Seattle, WA 98158

Statement regarding the "Amount of Contract " for Airline/Airport 2011 Lease and use Agreements

Revenue generated by this Contract is comprised terminal rental, and the formulas for each is listed below:

Exclusive Use Space calculated by Airport Rates and Charges, as shown on Exhibit O of the 2011 Lease.

Joint Use Space calculated by Airport Rates and Charges, as shown on Exhibit E of the 2011 Lease

Preferential Use Space calculated by Airport Rates and Charges, as shown on Exhibit O of the 2011 Lease.

Landing Fees care also calculated pursuant the Airport's Rates and Charges, as shown on Exhibit O of the 2011 Lease.

A copy of the 2011 Lease is attached for your reference.

