

File No. 190166

Committee Item No. 2
Board Item No. 10

COMMITTEE/BOARD OF SUPERVISORS
AGENDA PACKET CONTENTS LIST

Committee: Budget & Finance Sub-Committee

Date March 13, 2019

Board of Supervisors Meeting

Date March 19, 2019

Cmte Board

- Motion
- Resolution
- Ordinance
- Legislative Digest
- Budget and Legislative Analyst Report
- Youth Commission Report
- Introduction Form
- Department/Agency Cover Letter and/or Report
- MOU
- Grant Information Form
- Grant Budget
- Subcontract Budget
- Contract/Agreement
- Form 126 – Ethics Commission
- Award Letter
- Application
- Public Correspondence

OTHER (Use back side if additional space is needed)

- PowerPoint Presentation
- _____
- _____
- _____
- _____
- _____
- _____
- _____
- _____
- _____

Completed by: Linda Wong Date March 8, 2019
Completed by: Linda Wong Date March 14, 2019

1 [Lease of City Property - La Cocina, Inc. - 101 Hyde Street - Annual Base Rent \$12,000]

2
3 **Resolution authorizing the Director of Property to execute a commercial lease between**
4 **the City and County of San Francisco and La Cocina, Inc., for the lease of City-owned**
5 **property located at 101 Hyde Street for a term to commence upon full execution of the**
6 **lease through December 31, 2025, for an annual base rent of \$12,000 plus percentage**
7 **rent of net income and a \$1,465,000 allowance for tenant improvements; adopting**
8 **California Environmental Quality Act findings; and making findings that the proposed**
9 **transaction is in conformance with the General Plan, and the eight priority policies of**
10 **Planning Code, Section 101.1.**

11
12 WHEREAS, The City, on behalf of the Mayor's Office of Housing and Community
13 Development ("MOHCD"), acquired Assessor's Parcel Block No. 0346, Lot No. 003A, located
14 at 101 Hyde Street in the City and County of San Francisco (the "Property") on August 5,
15 2016, (the "Acquisition Date"), for future redevelopment as permanent affordable housing (the
16 "Housing Redevelopment"); and

17 WHEREAS, MOHCD and the City's Office of Economic and Workforce Development
18 ("OEWD"), through the City's Real Estate Division ("RED"), issued a request for proposals on
19 October 28, 2016, ("RFP") soliciting competitive bids from 501c3 non-profit public benefit
20 corporations, to award the right to negotiate a lease of the approximately 7,500 square foot
21 currently-vacant building ("Premises") located on the Property for the specified purpose of
22 building, managing and operating an active, community-serving use at the Premises, until
23 such time period as the Housing Redevelopment occurs; and

1 WHEREAS, The proposal submitted by La Cocina, Inc. ("Tenant") was determined by
2 representatives from MOHCD, OEWD and RED to be the proposal that best met the goals
3 and objectives of the RFP; and

4 WHEREAS, Tenant currently leases the Property on a year to year basis under a lease
5 dated as of June 1, 2018, ("2018 Lease"), a copy of which is on file with the Clerk of the Board
6 of Supervisors in File No. 190166, at an annual rent of \$12,000 plus the percentage rent
7 described in the 2018 Lease, and the 2018 Lease allows Tenant to build, manage and,
8 operate restaurant, bar, and/or a market hall within the Premises ("Permitted Uses"); and

9 WHEREAS, RED, in consultation with MOHCD, OEWD and the Office of the City
10 Attorney, negotiated a new lease between City and Tenant dated March 1, 2019, ("Proposed
11 Lease"), a copy of which is on file with the Clerk of the Board of Supervisors in File No.
12 190166, that will allow Tenant to use the Premises for the Permitted Uses for a term that
13 begins once the Proposed Lease is fully executed ("Effective Date") and expires on December
14 31, 2025, at an annual rent of \$12,000 plus the percentage rent described in the Proposed
15 Lease and a \$1,465,000 allowance ("Allowance") for the tenant improvements needed at the
16 Premises to facilitate the Permitted Uses ("Tenant Improvements"), all of which the Director of
17 Property has determined to be equal to the Market Rent (as defined in San Francisco
18 Administrative Code Section 23.2) of the Proposed Lease; and

19 WHEREAS, If the Proposed Lease is fully executed, the 2018 Lease will terminate as
20 of the Effective Date; and

21 WHEREAS, The Proposed Lease requires Tenant to reimburse the City for its costs in
22 providing minimum utilities and fire and alarm system maintenance for the Premises and to
23 obtain, at Tenant's sole cost, any additional utilities and maintenance it desires for the
24 Premises; and
25

1 WHEREAS, On February 1, 2019, MOHCD requested \$1,000,000 from the San
2 Francisco Foundation (the "Gift") to offset the interim Property ownership costs incurred by the
3 City since the Acquisition Date and to fund interim activation of the Property (collectively, the
4 "Interim Uses"), which include any City payments for the Tenant Improvements; and

5 WHEREAS, On February 12, 2019, MOHCD submitted a Resolution to the Board of
6 Supervisors for authorization to accept the Gift and to expend it for the Interim Uses, a copy of
7 which is on file with the Clerk of the Board of Supervisors in File No. 190167 (the "Gift
8 Resolution"); and

9 WHEREAS, If the Gift Resolution becomes effective, MOHCD intends to use up to
10 \$940,000 of the Gift, plus \$525,000 in other City funds, to pay the Allowance; and

11 WHEREAS, The Planning Department, through General Plan Referral letter dated
12 August 30, 2017, ("Planning Letter"), which is on file with the Clerk of the Board of
13 Supervisors under File No. 190166 and incorporated herein by reference, has verified that the
14 Proposed Lease is consistent with the General Plan, and the eight priority policies under
15 Planning Code, Section 101.1, and categorically exempt from review under the California
16 Environmental Quality Act (California Public Resources Code Sections 21000 et seq.)
17 ("CEQA") under CEQA Guidelines, Section 15303; and

18 RESOLVED, That the Board of Supervisors finds the Proposed Lease is consistent
19 with the General Plan, and the eight priority policies of Planning Code, Section 101.1, and
20 adopts the Planning Department's CEQA findings and hereby incorporates such findings by
21 reference as though fully set forth in this Resolution; and, be it

22 FURTHER RESOLVED, That in accordance with the recommendation of the Director
23 of MOHCD and the Director of OEWD, if the Gift Resolution becomes effective, the Director of
24 Property is hereby authorized to take all actions, on behalf of the City, to execute the
25 Proposed Lease on the terms and conditions herein; and, be it

1 FURTHER RESOLVED, That if the Gift Resolution becomes effective, the Board of
2 Supervisors authorizes the Director of Property to enter into any amendments or modifications
3 to the Proposed Lease (including in each instance, without limitation, the attachment of
4 exhibits) that the Director of Property, in consultation with the City Attorney, determine are in
5 the best interests of the City, do not otherwise materially increase the obligations or liabilities
6 of, or materially decrease the benefits to, the City beyond those contemplated in this
7 Resolution, and are in compliance with all applicable laws, including the City's Charter; and,
8 be it

9 FURTHER RESOLVED, That within thirty (30) days of the Proposed Lease being fully
10 executed by all parties, RED shall provide a copy to the Clerk of the Board for inclusion into
11 the official file.

12
13
14
15
16
17
18
19
20
21
22
23
24
25

FY 18/19 Funds Available: \$525,000

Fund ID: 10010
Department ID: 232065
Project ID: 10023915 *Account ID: 0001*
Authority ID: 17198
Account ID: 538010

Fund ID: 10010
Department ID: 232065
Project ID: ~~1002531~~ *10022531*
Authority ID: 16652 *Account ID: 0128*
Account ID: 538010

Fund ID: 10010
Department ID: 232065
Project ID: 10023885 *Account ID: 0005*
Authority ID: 17165
Account ID: 538010

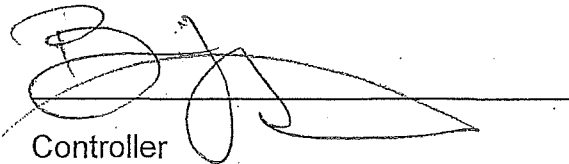
Controller

RECOMMENDED:

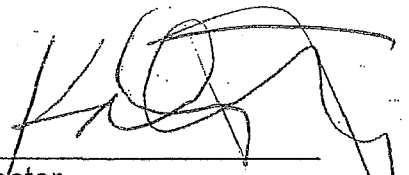
Director
Mayor's Office of Housing and Community Development

Director
Office of Economic and Workforce Development

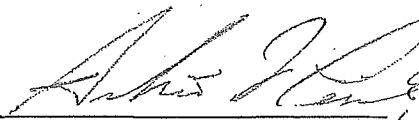
Director of Property *2/4/19*
Real Estate Division

<p>Items 2 and 3 Files 19-0166 and 19-0167 <i>Continued from February 27, 2019</i> <i>Budget and Finance Committee</i></p>	<p>Department: Mayor's Office of Housing and Community Development Real Estate Division</p>
---	--

EXECUTIVE SUMMARY

Legislative Objectives

File 19-0166 is a resolution authorizing the Director of the City's Real Estate Division to execute a commercial lease between City and La Cocina, Inc., for City-owned property located at 101 Hyde Street.

File 19-0167 is a resolution authorizing the Mayor's Office of Housing and Community Development to accept and expend a gift of \$1,000,000 from the San Francisco Foundation to the Neighborhood Development Special Revenue fund, and approves the City's use of the funds for the interim activation of 101 Hyde Street.

Key Points

- 101 Hyde Street is a City-owned parcel, conveyed to the City by the developer of market rate housing at 1066 Market Street in lieu of meeting the City's Inclusionary Affordable Housing requirements (approved by the Board of Supervisor through Ordinance 126-16). The property is slated for affordable housing development, but until sufficient funding is identified to develop the property, the Board of Supervisors approved the property for interim use for community serving purposes. In addition to the property conveyance, the developer donated \$6 million, of which \$1 million was for interim community use and \$5 million was for affordable housing development. These funds are held in trust by the San Francisco Foundation.
- The City selected the nonprofit organization, La Cocina, through a competitive solicitation to use the property for food oriented businesses. Under the proposed lease, La Cocina would make tenant improvements and operate a food hall, assisting low-income clients in launching self-sustaining businesses.
- The tenant improvements are scheduled for completion in November 2019. Upon issuance of the temporary certificate of occupancy, La Cocina will pay annual rent of \$12,000 and percentage rent equal to 5 percent of net revenues. The lease will extend through December 2025.

Fiscal Impact

- Tenant improvement costs are estimated to be \$4.6 million. Funding sources include \$1.4 million of City funds, including the \$1 million grant from the San Francisco Foundation and \$465,000 in previously appropriated funds; \$2.4 million secured by La Cocina through fundraising; and approximately \$780,000 to be obtained through additional fundraising or a bridge loan.

Recommendation

- Approval of the proposed resolutions is a policy matter for the Board of Supervisors.

MANDATE STATEMENT

City Administrative Code Section 10.170-1 states that accepting Federal, State, or third-party grant funds in the amount of \$100,000 or more, including any City matching funds required by the grant, is subject to Board of Supervisors approval.

City Administrative Code Section 23.30 requires Board of Supervisors approval for lease of City-owned property that is not required for City purposes. An appraisal of the fair market rent for the lease is not required if the Director of the City's Real Estate Division determines that the fair market rent is less than \$45 per square foot..

BACKGROUND

101 Hyde Street is a one story building at the corner of Golden Gate Avenue and Hyde Street consisting of approximately 7,500 square feet of space formerly used as a U.S. Postal Service Office. In August 2016, the owner of the land dedicated the site to the City through the Mayor's Office of Housing and Community Development (MOHCD) for the purpose of developing affordable housing. The dedication was a result of Ordinance 126-16 which waived the Inclusionary Affordable Housing requirements set forth in Planning Code Section 415, exempting the market rate residential development at 1066 Market Street (affiliated with the Shorenstein Properties LLC) from such requirements in exchange for the dedication of real property.

DETAILS OF PROPOSED LEGISLATION

File 19-0166: The proposed resolution authorizes the Director of Real Estate to execute a commercial lease between City and La Cocina, Inc., for City-owned property located at 101 Hyde Street.

File 19-0167: The proposed resolution authorizes the Mayor's Office of Housing and Community Development to accept and expend a gift of \$1,000,000 from the San Francisco Foundation to the Neighborhood Development Special Revenue fund, and approves the City's use of the funds for the interim activation of 101 Hyde Street.

\$1,000,000 Gift (File 19-0167)

As noted above, the developer of the market rate housing at 1066 Market Street donated 101 Hyde Street to the City for affordable housing development in lieu of meeting the City's Inclusionary Affordable Housing requirements. In addition to the property donation, the developer donated \$6 million for the development of 101 Hyde Street; \$1 million was donated for temporary development of the site while the City raised additional funds for developing the site as permanent affordable housing, and \$5 million was donated for converting the space to affordable housing. The San Francisco Foundation agreed to be the temporary trustee of the funds until the site is ready for development.

The release of the \$1,000,000 gift would be used for temporary development of the site. According to the proposed resolution, the \$1,000,000 was given to the San Francisco Foundation for the purpose of (i) offsetting interim ownership costs incurred by the City for temporary use of the property; (ii) funding improvements to the property to support interim use; and (iii) funding miscellaneous expenses associated with interim use of the property until the property is developed as permanent affordable housing.

Commercial Lease (File 19-0166)

Original Lease

In 2016, the City's Real Estate Division in collaboration with the Office of Economic and Workforce Development (OEWD) and MOHCD solicited proposals for temporarily converting 101 Hyde Street to a community serving interim use through a competitive Request for Proposals (RFP) process. They received two proposals and selected La Cocina, Inc., a non-profit organization, as the proposer with the higher application and interview score. La Cocina specializes in assisting low-income clients in launching self-sustaining food oriented businesses. La Cocina proposed building a food hall with a commercial kitchen in the space which will include seven kiosks for full time vendors, and one kiosk for rotating pop-ups.

Between December 2016 and June 2018, a period of 18 months, the Real Estate Division and La Cocina worked to establish the terms of the commercial lease. The Real Estate Division entered into a lease with La Cocina in June 2018. The lease term was year-to-year for up to seven years. According to Mr. Josh Keene, Special Projects and Transactions Manager, the Real Estate Division consulted with the City Attorney's Office and did not consider the lease to be subject to Board of Supervisors approval for the initial one-year term under Administrative Code Section 23.31, which grants the Director of Real Estate the authority to enter into leases of one year or less for which the rent is less than \$15,000. Under the lease, upon issuance of a temporary certificate of occupancy, La Cocina will pay annual rent of \$12,000 and percentage rent of 5 percent of net income.

Proposed Lease

The proposed lease replaces the prior year-to-year lease and provides a mechanism for the City to release portions of the \$1 million gift, as well as additional City funds, to La Cocina. The lease term is for approximately six years and nine months from approximately March 1, 2019 through December 31, 2025. Upon issuance of a temporary certificate of occupancy, La Cocina would pay annual rent of \$12,000 and percentage rent equal to 5 percent of net income.

Tenant Improvements

The original lease and proposed lease are for the operation of a restaurant, bar, and/or food market hall. La Cocina is responsible to make tenant improvements at its sole cost, based on detailed architectural drawings included in the original lease. The City will reimburse La Cocina for tenant improvements up to \$1,465,000. Design development documents are completed and construction documents are 90 percent complete. Construction of tenant improvements is scheduled to begin in May 2019 and completion of tenant improvements is expected in November 2019.

FISCAL IMPACT

The project budget for tenant improvements to 101 Hyde Street is \$4,600,000 as shown below in Table 1.

Table 1: Preliminary project budget for development at 101 Hyde Street

Sources	
<i>City Funds</i>	
San Francisco Foundation Grant	\$940,000
FY 2017-18 and FY 2018-19 Budget	465,000
Subtotal City Funds^a	\$1,405,000
<i>La Cocina Funds</i>	
La Cocina Funds	\$1,662,478
US Department of Health and Human Services	750,000
Subtotal La Cocina^b	\$2,412,478
Subtotal City and La Cocina Funds	\$3,817,478
Bridge Loan or Other Fundraising ^c	782,522
Total Sources	\$4,600,000
Uses	
Design and Engineering Costs	\$83,625
Permits and Utilities	24,386
Construction Hard Costs	4,013,100
Furniture, Fixtures, and Equipment	152,000
Administration	70,000
Subtotal	\$4,343,111
Contingency (6%)	256,889
Total Uses	\$4,600,000

^a Of the \$1 million San Francisco Foundation grant, \$60,000 is allocated to Real Estate Division costs and \$940,000 is allocated to the 101 Hyde Street project. Total City contribution is \$1,465,000, including \$60,000 in Real Estate Division costs, \$940,000 in the San Francisco Foundation grant, and \$465,000 previously appropriated by the Board of Supervisors in the FY 2017-18 and FY 2018-19 budgets.

^b La Cocina has \$2,412,478 in funds previously received, approved, or pledged from foundations, corporations, individuals, and federal grants.

^c The funding gap of \$782,522 is expected to come from additional fundraising by La Cocina, or if necessary, from a bridge loan to La Cocina from Dignity Health.

RECOMMENDATION

Approval of the proposed resolutions is a policy matter for the Board of Supervisors.

<p>Items 19 and 20 Files 19-0166 and 19-0167</p>	<p>Department: Mayor's Office of Housing and Community Development Real Estate Division</p>
---	--

EXECUTIVE SUMMARY

Legislative Objectives

File 19-0166 is a resolution authorizing the Director of the City's Real Estate Division to execute a commercial lease between City and La Cocina, Inc., for City-owned property located at 101 Hyde Street.

File 19-0167 is a resolution authorizing the Mayor's Office of Housing and Community Development to accept and expend a gift of \$1,000,000 from the San Francisco Foundation to the Neighborhood Development Special Revenue fund, and approves the City's use of the funds for the interim activation of 101 Hyde Street.

Key Points

- 101 Hyde Street is a City-owned parcel, conveyed to the City by the developer of market rate housing at 1066 Market Street in lieu of meeting the City's Inclusionary Affordable Housing requirements (approved by the Board of Supervisor through Ordinance 126-16). The property is slated for affordable housing development, but until sufficient funding is identified to develop the property, the Board of Supervisors approved the property for interim use for community serving purposes. In addition to the property conveyance, the developer donated \$6 million, of which \$1 million was for interim community use and \$5 million was for affordable housing development. These funds are held in trust by the San Francisco Foundation.
- The City selected the nonprofit organization, La Cocina, through a competitive solicitation to use the property for food oriented businesses. Under the proposed lease, La Cocina would make tenant improvements and operate a food hall, assisting low-income clients in launching self-sustaining businesses.
- The tenant improvements are scheduled for completion in November 2019. Upon issuance of the temporary certificate of occupancy, La Cocina will pay annual rent of \$12,000 and percentage rent equal to 5 percent of net revenues. The lease will extend through December 2025.

Fiscal Impact

- Tenant improvement costs are estimated to be \$4.6 million. Funding sources include \$1.4 million of City funds, including the \$1 million grant from the San Francisco Foundation and \$465,000 in previously appropriated funds; \$2.4 million secured by La Cocina through fundraising; and approximately \$780,000 to be obtained through additional fundraising or a bridge loan.

Recommendation

- Approve the proposed resolution.

MANDATE STATEMENT

City Administrative Code Section 10.170-1 states that accepting Federal, State, or third-party grant funds in the amount of \$100,000 or more, including any City matching funds required by the grant, is subject to Board of Supervisors approval.

City Administrative Code Section 23.30 requires Board of Supervisors approval for lease of City-owned property that is not required for City purposes. An appraisal of the fair market rent for the lease is not required if the Director of the City's Real Estate Division determines that the fair market rent is less than \$45 per square foot..

BACKGROUND

101 Hyde Street is a one story building at the corner of Golden Gate Avenue and Hyde Street consisting of approximately 7,500 square feet of space formerly used as a U.S. Postal Service Office. In August 2016, the owner of the land dedicated the site to the City through the Mayor's Office of Housing and Community Development (MOHCD) for the purpose of developing affordable housing. The dedication was a result of Ordinance 126-16 which waived the Inclusionary Affordable Housing requirements set forth in Planning Code Section 415, exempting the market rate residential development at 1066 Market Street (affiliated with the Shorenstein Properties LLC) from such requirements in exchange for the dedication of real property.

DETAILS OF PROPOSED LEGISLATION

File 19-0166: The proposed resolution authorizes the Director of Real Estate to execute a commercial lease between City and La Cocina, Inc., for City-owned property located at 101 Hyde Street.

File 19-0167: The proposed resolution authorizes the Mayor's Office of Housing and Community Development to accept and expend a gift of \$1,000,000 from the San Francisco Foundation to the Neighborhood Development Special Revenue fund, and approves the City's use of the funds for the interim activation of 101 Hyde Street.

\$1,000,000 Gift (File 19-0167)

As noted above, the developer of the market rate housing at 1066 Market Street donated 101 Hyde Street to the City for affordable housing development in lieu of meeting the City's Inclusionary Affordable Housing requirements. In addition to the property donation, the developer donated \$6 million for the development of 101 Hyde Street; \$1 million was donated for temporary development of the site while the City raised additional funds for developing the site as permanent affordable housing, and \$5 million was donated for converting the space to affordable housing. The San Francisco Foundation agreed to be the temporary trustee of the funds until the site is ready for development.

The release of the \$1,000,000 gift would be used for temporary development of the site. According to the proposed resolution, the \$1,000,000 was given to the San Francisco Foundation for the purpose of (i) offsetting interim ownership costs incurred by the City for temporary use of the property; (ii) funding improvements to the property to support interim use; and (iii) funding miscellaneous expenses associated with interim use of the property until the property is developed as permanent affordable housing.

Commercial Lease (File 19-0166)

Original Lease

In 2016, the City's Real Estate Division in collaboration with the Office of Economic and Workforce Development (OEWD) and MOHCD solicited proposals for temporarily converting 101 Hyde Street to a community serving interim use through a competitive Request for Proposals (RFP) process. They received two proposals and selected La Cocina, Inc., a non-profit organization, as the proposer with the higher application and interview score. La Cocina specializes in assisting low-income clients in launching self-sustaining food oriented businesses. La Cocina proposed building a food hall with a commercial kitchen in the space which will include seven kiosks for full time vendors, and one kiosk for rotating pop-ups.

Between December 2016 and June 2018, a period of 18 months, the Real Estate Division and La Cocina worked to establish the terms of the commercial lease. The Real Estate Division entered into a lease with La Cocina in June 2018. The lease term was year-to-year for up to seven years. According to Mr. Josh Keene, Special Projects and Transactions Manager, the Real Estate Division consulted with the City Attorney's Office and did not consider the lease to be subject to Board of Supervisors approval for the initial one-year term under Administrative Code Section 23.31, which grants the Director of Real Estate the authority to enter into leases of one year or less for which the rent is less than \$15,000. Under the lease, upon issuance of a temporary certificate of occupancy, La Cocina will pay annual rent of \$12,000 and percentage rent of 5 percent of net income.

Proposed Lease

The proposed lease replaces the prior year-to-year lease and provides a mechanism for the City to release portions of the \$1 million gift, as well as additional City funds, to La Cocina. The lease term is for approximately six years and nine months from approximately March 1, 2019 through December 31, 2025. Upon issuance of a temporary certificate of occupancy, La Cocina would pay annual rent of \$12,000 and percentage rent equal to 5 percent of net income.

Tenant Improvements

The original lease and proposed lease are for the operation of a restaurant, bar, and/or food market hall. La Cocina is responsible to make tenant improvements at its sole cost, based on detailed architectural drawings included in the original lease. The City will reimburse La Cocina for tenant improvements up to \$1,465,000. Design development documents are completed and construction documents are 90 percent complete. Construction of tenant improvements is scheduled to begin in May 2019 and completion of tenant improvements is expected in November 2019.

FISCAL IMPACT

The project budget for tenant improvements to 101 Hyde Street is \$4,600,000 as shown below in Table 1.

Table 1: Preliminary project budget for development at 101 Hyde Street

Sources	
<i>City Funds</i>	
San Francisco Foundation Grant	\$940,000
FY 2017-18 and FY 2018-19 Budget	465,000
Subtotal City Funds^a	\$1,405,000
<i>La Cocina Funds</i>	
La Cocina Funds	\$1,662,478
US Department of Health and Human Services	750,000
Subtotal La Cocina^b	\$2,412,478
Subtotal City and La Cocina Funds	\$3,817,478
Bridge Loan or Other Fundraising ^c	782,522
Total Sources	\$4,600,000
Uses	
Design and Engineering Costs	\$83,625
Permits and Utilities	24,386
Construction Hard Costs	4,013,100
Furniture, Fixtures, and Equipment	152,000
Administration	70,000
Subtotal	\$4,343,111
Contingency (6%)	256,889
Total Uses	\$4,600,000

^a Of the \$1 million San Francisco Foundation grant, \$60,000 is allocated to Real Estate Division costs and \$940,000 is allocated to the 101 Hyde Street project. Total City contribution is \$1,465,000, including \$60,000 in Real Estate Division costs, \$940,000 in the San Francisco Foundation grant, and \$465,000 previously appropriated by the Board of Supervisors in the FY 2017-18 and FY 2018-19 budgets.

^b La Cocina has \$2,412,478 in funds previously received, approved, or pledged from foundations, corporations, individuals, and federal grants.

^c The funding gap of \$782,522 is expected to come from additional fundraising by La Cocina, or if necessary, from a bridge loan to La Cocina from Dignity Health.

RECOMMENDATION

Approve the proposed resolution.

LEASE

between

CITY AND COUNTY OF SAN FRANCISCO,
as Landlord

and

LA COCINA, INC.,
as Tenant

For the lease of
101 Hyde Street
San Francisco, California

March 1, 2019

TABLE OF CONTENTS

LIST OF EXHIBITS

- EXHIBIT A – Legal Description and Depiction of Premises
- EXHIBIT B – Work Letter
- EXHIBIT C – Amended Easement Agreements
- EXHIBIT D – Notice of Rent Commencement Date
- EXHIBIT E – Tenant’s Plans and Specifications
- EXHIBIT F – Form of Performance Bond
- EXHIBIT G – Standard Utilities
- EXHIBIT H – Rules and Regulations
- EXHIBIT I – First Source Hiring Agreement
- EXHIBIT J – Maintenance Agreements

LEASE

THIS LEASE (this "Lease"), dated for reference purposes only as of March 1, 2019, is between the CITY AND COUNTY OF SAN FRANCISCO, a municipal corporation ("City"), and LA COCINA, INC., a California non-profit corporation ("Tenant").

City and Tenant hereby covenant and agree as follows:

1. BASIC LEASE INFORMATION

The following is a summary of basic lease information (the "Basic Lease Information"). Each item below shall be deemed to incorporate all of the terms in this Lease pertaining to such item. In the event of any conflict between the information in this Section and any more specific provision of this Lease, the more specific provision shall control.

Lease Reference Date:	March 1, 2019
Landlord:	CITY AND COUNTY OF SAN FRANCISCO, a municipal corporation
Tenant:	La Cocina, Inc. (and any permitted successors and assigns)
Building (<u>Section 2.1</u>):	Building located at 101 Hyde Street San Francisco, California ("Building")
Premises (<u>Section 2.1</u>):	The real property commonly known as 101 Hyde Street (Assessor's Block 0346 / Lot 003A ("Property")), as more particularly described and shown on <u>Exhibit A</u> , together with the Building and any other improvements located thereon
Rentable Area of Premises (<u>Section 2.1</u>):	Approximately 7,500 gross square feet
Term (<u>Section 3.1</u>):	Commencing on the full execution of this Lease ("Effective Date") and terminating on December 31, 2025
Base Rent (<u>Section 4.1</u>):	Annual Base Rent: \$12,000.00 Monthly payments: \$1,000.00
Percentage Rent (<u>Section 4.2</u>):	Annual payments ("Percentage Rent") equal to five percent (5%) of Net Income (as defined in <u>Section 4.2</u>)
Use (<u>Section 5.1</u>):	Operation of a restaurant, bar, and/or market hall, or any other legal use approved in advance by the Director of Property in consultation with the Director of City's Office of Workforce and Economic Development ("OEWD").
Tenant Improvements (<u>Section 6.1</u>):	Tenant shall perform, at its sole cost, the Tenant Improvements (as defined in <u>Section 6.1</u>); provided, however, that City shall reimburse

Tenant up to \$1,465,000 for the Tenant Improvement construction costs incurred by Tenant on the conditions specified in the work letter attached hereto as Exhibit B ("Work Letter").

Utilities and Services (Section 10.1):

City shall provide the Standard Utilities (as defined in Section 10.1) and the Fire and Alarm System Maintenance (as defined in Section 10.1); provided, however, that Tenant shall reimburse City for such costs. Tenant shall provide, at its sole cost, all other utilities and services it wishes to receive at the Premises.

Security Deposit:

None.

Notice Address of City (Section 27.1):

Real Estate Division
25 Van Ness Avenue, Suite 400
San Francisco, California 94102
Attn: Director of Property
Re: **101 Hyde Street – La Cocina Lease**
Fax No.: (415) 552-9216

with a copy to:

Office of Economic and Workforce Development
City Hall, Room 448
1 Dr. Carlton B. Goodlett Place
San Francisco, CA 94102-4653
Attn: Director
Re: **101 Hyde Street – La Cocina Lease**
Fax No.: (415) 554-6018

and to:

Office of the City Attorney
City Hall, Room 234
1 Dr. Carlton B. Goodlett Place
San Francisco, California 94102-4682
Attn: Carol Wong
Deputy City Attorney
Re: **101 Hyde Street – La Cocina Lease**
Fax No.: (415) 554-4757

Key Contact for City:

Josh Keene

Telephone No.:

(415) 554-9859

Alternate Contact for City:

Mara Blitzer

Telephone No.:

(415) 701-5544

Address for Tenant (Section 27.1):

2948 Folsom Street
San Francisco, CA 94110

Key Contact for Tenant:

Caleb Zigas

Telephone No.:

(415) 824-2729 x 304

Alternate Contact for Tenant:

Leticia Landa

101 Hyde St.

2

428

Telephone No.: (415) 824-2729

Brokers (Section 27.8): None.

2. PREMISES; AS IS CONDITION

2.1 Lease Premises

Subject to the provisions of this Lease, City leases to Tenant and Tenant leases from City those premises identified in the Basic Lease Information (the "Premises"). The rentable area of the Premises specified in the Basic Lease Information shall be conclusive for all purposes hereof. The Premises shall include the Property, the Building, and all other improvements on and appurtenances to the Property.

2.2 Accessibility Disclosures

(a) California Civil Code Section 1938 requires commercial landlords to disclose to tenants whether the property being leased has undergone inspection by a Certified Access Specialist ("CASp") to determine whether the property meets all applicable construction-related accessibility requirements. The law does not require landlords to have the inspections performed. Tenant is hereby advised that the Premises have not been inspected by a CASp.

(b) Tenant acknowledges that prior to the execution of this Lease, City provided Tenant with, and Tenant signed, the Disability Access Obligations Notice described in Section 38.3 of the San Francisco Administrative Code. Tenant and City each agree to use reasonable efforts to notify the other party if making any Alterations (as defined in Section 7.1 (Tenant's Alterations)) that might impact accessibility to the Premises under any disability access laws.

2.3 As Is Condition

TENANT ACKNOWLEDGES AND AGREES THE PREMISES ARE BEING LEASED AND ACCEPTED IN THEIR "AS IS" CONDITION, WITHOUT REPRESENTATION OR WARRANTY OF ANY KIND, AND SUBJECT TO ALL APPLICABLE LAWS, RULES AND ORDINANCES GOVERNING THEIR USE, OCCUPANCY AND POSSESSION. TENANT REPRESENTS AND WARRANTS TO CITY THAT TENANT HAS INVESTIGATED AND INSPECTED, EITHER INDEPENDENTLY OR THROUGH AGENTS OF TENANT'S OWN CHOOSING, THE CONDITION OF THE PREMISES AND THE SUITABILITY OF THE PREMISES FOR TENANT'S INTENDED USE. TENANT HAS DETERMINED, BASED SOLELY ON ITS OWN INVESTIGATION, THAT THE PREMISES ARE SUITABLE FOR TENANT'S BUSINESS AND INTENDED USE. TENANT ACKNOWLEDGES AND AGREES THAT NEITHER CITY NOR ANY OF ITS AGENTS HAVE MADE, AND CITY HEREBY DISCLAIMS, ANY REPRESENTATIONS OR WARRANTIES, EXPRESS OR IMPLIED, CONCERNING THE RENTABLE AREA OF THE PREMISES, THE PHYSICAL OR ENVIRONMENTAL CONDITION OF THE PREMISES, THE PRESENT OR FUTURE SUITABILITY OF THE PREMISES FOR TENANT'S BUSINESS, THE PRESENCE OR ABSENCE OF ANY HAZARDOUS MATERIALS, OR ANY OTHER MATTER WHATSOEVER RELATING TO THE PREMISES, INCLUDING, WITHOUT LIMITATION, ANY IMPLIED WARRANTIES OF MERCHANTABILITY OR FITNESS FOR A PARTICULAR PURPOSE.

2.4 Access Easements

The Property is subject to pedestrian and vehicular access easements that benefit the properties commonly known as 125 Hyde Street and 129 Hyde Street in San Francisco, California, as further described in the grant deeds recorded in the Official Records of San Francisco County at Book 2378 Page 191, Book 3846 Page 230, and Book 2162 Page 285, and

as amended by the Easement Amendment and Agreements (together, the "Amended Easement Agreements") recorded in the Official Records of San Francisco County on August 5, 2016, as Instrument No. 2016-K302894 and Instrument No. 2016-K302895. Copies of the Amended Easement Agreements are attached as Exhibit C.

Tenant acknowledges and agrees that the easement area described in the Amended Easement Agreements (the "Easement Area") is subject to the Permitted Uses (as defined in the Amended Easement Agreements) at all times except during limited closure periods permitted under the Amended Easement Agreements. Tenant shall obtain the prior written consent of City and all the fee owners of 125 Hyde Street and 129 Hyde Street before taking any action that limits or negatively impacts the use of the Easement Area for the Permitted Uses.

2.5 Energy Consumption Disclosure

Tenant consents to Tenant's utility service providers disclosing energy use data for the Premises to City for use under California Public Resources Code Section 25402.10, as implemented under California Code of Regulations Sections 1680-1685, and San Francisco Environment Code Chapter 20, as each may be amended from time to time ("Energy Consumption Reporting Laws"), and for such data to be publicly disclosed under the Energy Consumption Reporting Laws.

3. TERM

3.1 Lease Term

The Premises are leased for a term (the "Term") commencing on the Effective Date. The Term of this Lease shall end on the expiration date specified in the Basic Lease Information, unless sooner terminated pursuant to the provisions of this Lease. City shall deliver the Premises to Tenant on the Effective Date in their then existing as is condition as further provided above, with no obligation of the City to make any improvements, repairs or alterations.

3.2 Confirmation of Rent Commencement Date and Expiration Date

The "Rent Commencement Date" shall be the date the Tenant Improvement Work (as defined in Section 6.1) is completed and City's Department of Building Inspection has issued a temporary certificate of occupancy for the Building. The Term shall terminate on December 31, 2025 (the "Expiration Date"), unless sooner terminated pursuant to the provisions of this Lease. Promptly following the Rent Commencement Date, Tenant shall deliver to City a notice substantially in the form attached hereto as Exhibit D, confirming the actual Rent Commencement Date and the Expiration Date, but Tenant's failure to do so shall not affect the date of either the Rent Commencement Date or the Expiration Date.

3.3 Termination of 2018 Lease

Immediately prior to the Effective Date, Tenant leased the Premises from City under a lease dated as of June 1, 2018 (the "2018 Lease"). The 2018 Lease shall automatically terminate as of 11:59 pm the day immediately preceding the Effective Date.

4. RENT

4.1 Base Rent

Throughout the Term beginning on the Rent Commencement Date, Tenant shall pay to City the annual Base Rent specified in the Basic Lease Information (the "Base Rent"). The Base Rent shall be paid to City in advance, without prior demand and without any deduction, setoff or counterclaim whatsoever, in equal consecutive monthly payments on or before the first day of

the Term and on or before the first day of each month thereafter. If the Rent Commencement Date occurs on a day other than the first day of a calendar month, or the Expiration Date occurs on a day other than the last day of a calendar month, then the Base Rent for such fractional month shall be prorated based on a thirty (30) day month. Within five (5) days after the Rent Commencement Date, Tenant shall pay to City the Base Rent for the month in which the Rent Commencement Date occurs and the following month.

4.2 Percentage Rent

(a) Definitions

(i) "Books and Records" means all of Tenant's (and each of its Agent's) books, records, and accounting reports or statements relating to its business at or use of the Premises, this Lease, the Tenant Improvements, any Alterations, and the operation and maintenance of the Premises, including, without limitation, cash journals, rent rolls, general ledgers, income statements, bank statements, income tax schedules relating to Tenant's business in or use of the Premises, and any other bookkeeping documents Tenant utilizes in its business operations for the Premises. Tenant shall maintain a separate set of accounts to allow a determination of all Operating Expenses, all Operating Income generated directly from the Premises, and all exclusions therefrom.

(ii) "Lease Year" means the twelve (12) month period immediately following the Rent Commencement Date or any anniversary of the Rent Commencement Date.

(iii) "Net Income" means the Operating Income less the Expenses for a Lease Year (or portion thereof).

(iv) "Operating Expenses" means the following reasonable operating and routine maintenance and repair expenses incurred in the operation of the Premises for the uses permitted under this Lease and performing Tenant's obligations under this Lease: (1) commercially-reasonable administrative, payroll, security and general expenses for the Premises; (2) charges for utility services; (3) expenses for repair and maintenance of equipment and furnishings; (4) expenses for routine maintenance and repair of and for cleaning the Premises, including, without limitation, expenses related to vandalism or other damage to the Premises or Tenant's equipment or supplies at the Premises; (5) the cost of supplies and equipment reasonably necessary for the operation of the Premises for the uses permitted under this Lease; (6) license and permit fees not related to the Tenant Improvements or any Alterations; (7) the cost of the insurance policies that Tenant must carry under Article 19 below or to comply with applicable laws to otherwise reasonably insure Tenant against liability relating to the management and operation of the Premises, including workers' compensation insurance, fidelity and surety bonds, casualty insurance, business interruption insurance, and any deductible amounts required under such insurance policies; (8) sales taxes, payroll taxes and all other taxes resulting from operation of the Premises; (9) possessory interest taxes; (10) other expenses incurred by Tenant under this Lease other than the payment of Base Rent or Percentage Rent; (11) the cost of utilities incurred in connection with the use and operation of the Premises; (12) costs and fees of independent professions (including, without limitation, legal, accounting, consultants and other professional expenses), technical consultants, operational experts (including quality assurance inspectors) or other third parties retained to perform services required or permitted hereunder, except to the extent incurred with respect to the design or installation of the Tenant Improvements; and (13) all other costs and expenses that are reasonable and customary operating and maintenance expenses incurred in the operation, leasing, marketing and maintenance of the Premises for the Permitted Use and in compliance with this Lease and approved by City's Director of Property in writing. Operating Expenses shall not include any charges or allowances for depreciation or amortization of Tenant's interest in the Premises or any costs or expenses incurred by Tenant as a result of any default of its obligations under this Lease.

(v) "Operating Income" means, subject only to the exceptions stated below, all sales, payments, revenues, income, fees, rentals, receipts, proceeds and amounts of any kind whatsoever, whether for cash, credit or barter, received or receivable by Tenant from any business, use or occupation (but not those received or receivable by any of its subtenants or Vendors, as defined in Section 16.1 below), or any combination thereof, transacted, arranged or performed, in whole or in part, on the Premises, including without limitation, all returns and refunds, employee meals, discounted and complimentary meals, beverages and services or similar benefits and/or goodwill, the total value, based on price, for the tickets, cover charges, merchandise and any other items and the operation of any event, including any special or fundraising event, and catering or food delivery business conducted by, from or at the Premises (irrespective of where the orders therefor originated or are accepted and irrespective of where the food or beverages are consumed). Except as specified below, Operating Income shall be determined without reserve or deduction for failure or inability to collect (including, without limitation, spillage and waste) and without deduction or allowance for cost of goods sold or other costs, charges or expenses of purchasing or selling incurred by Tenant. No value added tax, no franchise or capital stock tax and no income, gross receipts or similar tax based upon income, profits or gross receipts as such shall be deducted from Operating Income. The following shall be excluded from Operating Income, provided that, Tenant provide separate records to City to support such deductions or exclusions, as the case may be, and separate notations are made for same on the Annual Statements (as defined in Section 4.2(b)):

(A) The amount of any refund made or credit allowed due to a bona fide complaint from a customer concerning the quality of food, beverages, merchandise or service by Tenant;

(B) Sales by redemption of gift certificates or like vouchers, but only to the extent previously reported as part of Operating Income;

(C) Sums collected for any sales or excise tax imposed directly upon Tenant by any duly constituted governmental authority, but only if stated separately from the selling price of the goods or merchandise, or services, and collected from customers and such amounts are in fact paid to the appropriate governmental entities for which they are collected; and

(D) All food and beverage sales to employees of Tenant, not to exceed, however, one percent (1%) of Operating Income in any single month, and provided further that said sales are at a discount; and

(E) Tips paid to Tenant's employees by its customers, so long as such tips go directly to Tenant's employees (and not Tenant or Tenant's management); and

(F) Bona fide promotional discounts to Tenant's customers for food, beverages and other sales, up to a maximum of five percent (5%) of Operating Income in any single month.

(b) Annual Statements

On or before the sixtieth (60th) day immediately following each anniversary of the Rent Commencement Date, Tenant shall deliver a complete statement (each, an "Annual Statement") showing the computation of the Percentage Rent for the immediately preceding Lease Year in a form approved by City. Each Annual Statement shall set forth in reasonable detail the Operating Income for the immediately preceding Lease Year, including an itemized list of any and all deductions or exclusions from Operating Income that Tenant may claim and which are expressly permitted under this Lease, the Operating Expenses for the immediately preceding Lease Year, and a computation of the Percentage Rent for the immediately preceding Lease

Year. Each Annual Statement shall be certified as accurate, complete and current by an independent certified public accounting firm acceptable to City's Director of Property in his or her sole discretion.

If Tenant fails to deliver any Annual Statement within the time period set forth in this subsection (irrespective of whether any Percentage Rent is actually paid or due to City for the preceding Lease Year) and such failure continues for three (3) days after the date Tenant receives (or refuses receipt of) written notice of such failure from City, City shall have the right, among its other remedies under this Lease, to employ a certified public accountant to make such examination of Tenant's Books and Records (and the Books and Records of any other occupant of the Premises) as may be necessary to certify the amount of the Operating Income and Operating Expenses for the period in question. Such certification shall be binding upon Tenant and Tenant shall promptly pay to City the total reasonable cost of the examination and City's other reasonable costs (including attorneys' fees) in exercising its examination rights hereunder, together with the full amount of Percentage Rent due and payable for the period in question. Tenant acknowledges that the late submittal of any Annual Statement will cause City increased costs not contemplated by this Lease, the exact amount of which will be extremely difficult to ascertain. The parties agree that the charges set forth in this Section represent a fair and reasonable estimate of the cost that City will incur by reason of Tenant's lateness.

(c) Payments

On or before the one hundred twentieth (120th) day immediately following each anniversary of the Rent Commencement Date, Tenant shall pay to City, in addition to the monthly Base Rent payable by Tenant pursuant to Section 4.1 above, Percentage Rent for the Lease Year immediately preceding such payment date. Notwithstanding anything to the contrary in the foregoing sentence, if this Lease terminates prior to the anniversary of a Rent Commencement Date, Tenant shall pay to City a final payment of Percentage Rent on or before the sixtieth (60th) day immediately following such termination, which payment shall be in an amount equal to five percent (5%) of the Net Income for the period (i) between the last anniversary of the Rent Commencement Date before such termination date and (ii) the termination of this Lease.

City's acceptance of any monies paid to City by Tenant as Percentage Rent as shown by the applicable Annual Statement shall not be an admission of the accuracy of such Annual Statement or the amount of such Percentage Rent payment. City's receipt of a portion of Tenant's Net Income as Percentage Rent shall be deemed strictly as rental and nothing herein shall be construed to create the legal relation of a partnership or joint venture between City and Tenant.

(d) Books and Records

Tenant agrees that the business of Tenant upon the Premises shall be operated with a non-resettable register and so that a duplicate dated sales slip or such other recording method reasonably acceptable to City is issued with each sale, whether for cash, credit or exchange. Furthermore, Tenant shall keep (and shall cause its subtenants and assignees to keep) at the Premises, at all times between the Rent Commencement Date and the expiration or earlier termination of this Lease, complete and accurate Books and Records that contain all information required to permit City to verify Operating Income, deductions and exclusions therefrom, and Operating Expenses that are in accordance with this Lease and with generally accepted accounting practices consistently applied from period to period with respect to all operations of the business to be conducted in or from the Premises. Tenant shall retain (and shall cause its subtenants and assignees to retain) such Books and Records for a period (the "Audit Period") that is the later of (i) four (4) years after the end of each Lease Year (or portion thereof) to which such Books and Records apply or, (ii) if an audit is commenced or if a controversy

should arise between the parties hereto regarding the Percentage Rent payable hereunder, until such audit or controversy is terminated.

(e) Audit

Tenant shall make its Books and Records available to City, any City auditor, or any auditor or representative designated by City (each referred to in this subsection as "City's Audit Representative"), on no less than fifteen (15) business days' prior written notice to Tenant, for the purpose of examining said Books and Records to determine the accuracy of Tenant's reporting of Percentage Rent for a period not to exceed the Audit Period after a Percentage Statement is delivered to City. Tenant shall cooperate with the City's Audit Representative during the course of any audit, provided however, such audit shall occur at Tenant's business office, or at such other location in San Francisco where the Books and Records are kept, and no books or records shall be removed by City's Audit Representative without the prior express written consent of Tenant (provided, however, copies may be made by City's Audit Representative on site), and once commenced, with Tenant's cooperation, such audit shall be diligently pursued to completion by City within a reasonable time of its commencement, provided that Tenant makes available to City's Audit Representative all the relevant Books and Records in a timely manner. If an audit is made of the Books and Records and City claims that errors or omissions have occurred, the Books and Records shall be retained by Tenant and made available to City's Audit Representative until those matters are expeditiously resolved with Tenant's cooperation. If Tenant operates the Premises through one or more subtenants or Agents; Tenant shall require each such subtenant or Agent to provide City with the foregoing audit right with respect to its Books and Records. Upon completion of the audit, City shall promptly deliver a copy of the audit report to Tenant.

If an audit reveals that Tenant has understated its Net Income for the applicable audit period, Tenant shall pay City, promptly upon demand, the difference between the Percentage Rent payment Tenant has paid and the Percentage Rent payment it should have paid to City, plus interest from the date of the error in the payment equal to ten percent (10%) per year or, if a higher rate is legally permissible, the highest rate an individual is permitted to charge under applicable law, if City elects to charge such interest. If an audit reveals that Tenant has overstated its Net Income for the applicable audit period, Tenant shall be entitled to a credit equal to the difference between the amount Tenant has paid and the amount it should have paid to City against the next installment of Percentage Rent owed by Tenant. If Tenant understates the Net Income for any audit period by three percent (3%) or more, Tenant shall pay the reasonable cost of the audit. A second understatement of three percent (3%) or more within any three (3) Lease Year period of the first such understatement shall be considered an Event of Default.

4.3 Additional Charges

Tenant shall pay to City any and all charges and other amounts required under this Lease as additional rent (collectively, "Additional Charges"). All such Additional Charges shall be payable to City at the same place and the same manner as the Base Rent and Percentage Rent are payable. City shall have the same remedies for a default in the payment of any Additional Charges as for a default in the payment of Base Rent or Percentage Rent. As used in this Lease, the term "Rent" shall include the Base Rent, Percentage Rent, Additional Charges and any other amounts Tenant is obligated to pay hereunder, whether or not any such amounts are specifically characterized as rent.

4.4 Late Charges

If Tenant fails to pay any Rent or any portion of Rent within five (5) days following the due date therefor, City shall have the right to require Tenant to pay a late payment charge for such late payment equal to six percent (6%) of the unpaid amount in each instance. The late

payment charge has been agreed upon by City and Tenant, after negotiation, as a reasonable estimate of the additional administrative costs and detriment that City will incur as a result of any such failure by Tenant, the actual costs thereof being extremely difficult if not impossible to determine. The late payment charge constitutes liquidated damages to compensate City for its damages resulting from such failure to pay and shall be paid to City together with such unpaid amount.

4.5 Default Interest

If any Rent or any portion of Rent is not paid within five (5) days following the due date therefor, City shall have the right to require Tenant to pay interest on such amount from the due date until paid at the rate of ten percent (10%) per year or, if a higher rate is legally permissible, at the highest rate an individual is permitted to charge under law (the "Interest Rate"). However, interest shall not be payable on late charges incurred by Tenant nor on any amounts on which late charges are paid by Tenant to the extent this interest would cause the total interest to be in excess of that which an individual is lawfully permitted to charge. Payment of interest shall not excuse or cure any default by Tenant.

4.5 Payments

All sums payable by Tenant to City hereunder shall be paid in cash or by good (cashier's or certified) check to the City and County of San Francisco in care of the Director of Property at the primary address for City specified in the Basic Lease Information, or such other place as City may designate in writing. If Tenant pays by check and such check is not honored, then City may require Tenant to make all future payments in cash or by cashier's check.

5. USE

5.1 Approved Use

Between the Effective Date and the Rent Commencement Date, Tenant shall only use the Premises to perform the Tenant Improvements and to install Tenant's Personal Property (as defined in Section 7.3 below) and for no other purpose unless approved in writing by the City's Director of Property in consultation with the Director of OEWD. Following the Rent Commencement Date, Tenant shall use and continuously occupy the Premises solely for the operation of a restaurant, bar, and/or food market hall and any other purpose approved in advance and in writing by the City's Director of Property in consultation with the Director of OEWD, all of which shall be in compliance with all applicable laws.

5.2 No Unlawful Uses, Nuisances or Waste

Without limiting the foregoing, Tenant shall not use, occupy or permit the use or occupancy of any of the Premises in any unlawful manner or for any illegal purpose, or permit any offensive, noisy or hazardous use or any waste on or about the Premises. Tenant shall take all precautions to eliminate any nuisances or hazards relating to its activities on or about the Premises. Tenant shall not conduct any business, place any sales display, or advertise in any manner in areas outside the Building except identification signs in a location and size and design approved by City in its sole discretion.

5.3 Prevailing Wages for Certain Uses

Tenant shall pay, and shall require its subtenants, and contractors and subcontractors (regardless of tier) to pay, prevailing wages, including fringe benefits or the matching equivalents thereof, to persons performing services for the following activity on the Premises as set forth in and to the extent required by San Francisco Administrative Code Chapter 21C: a Public Off-Street Parking Lot, Garage or Automobile Storage Facility (as defined in Section

21C.3), a Show (as defined in Section 21C.4), a Trade Show and Special Event (as defined in Section 21C.8), and Broadcast Services (as defined in Section 21C.9), Commercial Vehicles, Loading and Unloading for Shows and Special Events (as defined in Section 21C.10), and Security Guard Services for Events (as defined in Section 21C.11).

If Tenant, or its subtenants, contractors, and subcontractors fail to comply with the applicable obligations in San Francisco Administrative Code Chapter 21C, City shall have all available remedies set forth in Chapter 21C and the remedies set forth in this Lease. City may inspect and/or audit any workplace, job site, books and records pertaining to the applicable services and may interview any individual who provides, or has provided, such services. Tenant shall provide to City (and require any subtenant, contractor or subcontractor who maintains such records to provide to City) immediate access to all workers' time sheets, payroll records, and paychecks for inspection on request to the extent they relate to such services.

- The types of covered services related to a Show includes individuals engaged in theatrical or technical services, including rigging, sound, projection, theatrical lighting, videos, computers, draping, carpentry, special effects, and motion picture services.
- The types of covered services related to a Special Event includes individuals engaged in on-site installation, set-up, assembly, and dismantling of temporary exhibits, displays, booths, modular systems, signage, drapery, specialty furniture, floor coverings, and decorative materials in connection with trade shows, conventions, expositions, and other special events on City property.
- The types of covered services related to Broadcast Services includes individuals engaged in the electronic capture and/or live transmission of on-site video, digital, and/or video content for commercial purposes through the use of a remote production or satellite trust on-site, including any technical director, video controller, assistant director, and stage manager, and individuals engaged in audio, camera, capture and playback, graphics and utility functions.

6. TENANT IMPROVEMENTS

6.1 Tenant Improvement Work

City hereby approves the initial plans and specifications dated November 7, 2018 prepared by LMNOP Design Inc., Tenant's architect, copies of which are attached hereto as Exhibit E, for the construction and installation of the tenant improvements at the Premises (such work is referred to as the "Tenant Improvement Work" or "Tenant Improvements" and such plans and specifications are referred to as the "Plans"). Tenant shall cause the Tenant Improvement Work to be performed in accordance with the approved Plans, the standards contained in Section 7.1 (Tenant's Alterations) below, and the requirements of the Work Letter. Tenant shall be responsible, at no cost to City, for performing the Tenant Improvement Work and for obtaining all permits and licenses required in connection with the Tenant Improvements; provided, however, that City shall reimburse Tenant up to \$1,465,000 ("Allowance") for the Tenant Improvement Work construction costs incurred by Tenant on the conditions specified in the Work Letter. No Tenant Improvement Work shall commence in the Premises unless and until the Work Letter is fully executed and this Lease is approved by the City's Board of Supervisors and Mayor as further provided herein and is fully executed. Tenant shall not make any material change to the Plans or consent to any change order during the course of construction without first obtaining City's written approval.

Tenant shall ensure that all work is performed in a manner that does not obstruct access to or through the Building or interfere with the Fire and Alarm System Maintenance or the Permitted Uses. Upon completion of the Tenant Improvements, Tenant shall furnish City with a

copy of the final as-built plans and specifications. No approval by City or any of its Agents of the Plans, any changes thereto or of any Alterations for purposes of this Lease shall be deemed to constitute approval of any federal, state or local regulatory authority with jurisdiction over the Premises or Tenant's use hereunder (including City acting in its regulatory capacity), and nothing herein shall limit Tenant's obligation to obtain all such regulatory approvals at no cost to the City. If any Tenant Improvements would be visible from the exterior of the Building, Tenant, shall obtain the prior written approval of City's Arts Commission to the extent the Arts Commission has jurisdiction over the design of such proposed component under City's Charter Section 5.103.

6.2 Local Hiring Requirements

Any undefined, initially-capitalized term used in this Section shall have the meaning given to such term in San Francisco Administrative Code Section 23.62 (the "Local Hiring Requirements"). Tenant Improvements and Alterations (as defined in Section 7.1) are subject to the Local Hiring Requirements unless the cost for such work is (i) estimated to be less than \$750,000 per building permit or (ii) meets any of the other exemptions in the Local Hiring Requirements. Tenant agrees that it shall comply with the Local Hiring Requirements to the extent applicable. Before starting any Tenant Improvement Work or any Alteration, Tenant shall contact OEWD to verify if the Local Hiring Requirements apply to the work (i.e., whether the work is a "Covered Project").

Tenant shall include, and shall require its subtenants to include, a requirement to comply with the Local Hiring Requirements in any contract for a Covered Project with specific reference to San Francisco Administrative Code Section 23.62. Each such contract shall name the City and County of San Francisco as a third party beneficiary for the limited purpose of enforcing the Local Hiring Requirements, including the right to file charges and seek penalties. Tenant shall cooperate, and require its subtenants to cooperate, with the City in any action or proceeding against a contractor or subcontractor that fails to comply with the Local Hiring Requirements when required. Tenant's failure to comply with its obligations under this Section shall constitute a material breach of this Lease. A contractor's or subcontractor's failure to comply with this Section will enable the City to seek the remedies specified in San Francisco Administrative Code Section 23.62 against the breaching party.

6.3 Prevailing Wages and Working Conditions

Any undefined, initially-capitalized term used in this Section shall have the meaning given to such term in San Francisco Administrative Code Section 23.61. Tenant shall require its Contractors and Subcontractors performing (i) labor in connection with a "public work" as defined under California Labor Code Section 1720 *et seq.* (which includes certain construction, alteration, maintenance, demolition, installation, repair, carpet laying, or refuse hauling work if paid for in whole or part out of public funds) or (ii) Covered Construction, at the Premises to (1) pay workers performing such work not less than the Prevailing Rate of Wages, (2) provide the same hours, working conditions and benefits as in each case are provided for similar work performed in San Francisco County, and (3) employ Apprentices in accordance with San Francisco Administrative Code Section 23.61 (collectively, "Prevailing Wage Requirements"). Tenant agrees to cooperate with the City in any action or proceeding against a Contractor or Subcontractor that fails to comply with the Prevailing Wage Requirements.

Tenant shall include, and shall require its subtenants, and Contractors and Subcontractors (regardless of tier), to include the Prevailing Wage Requirements and the agreement to cooperate in City enforcement actions in any Construction Contract with specific reference to San Francisco Administrative Code Section 23.61. Each such Construction Contract shall name the City and County of San Francisco, affected workers, and employee organizations formally representing affected workers as third party beneficiaries for the limited purpose of enforcing the Prevailing Wage Requirements, including the right to file charges and seek penalties against any

Contractor or Subcontractor in accordance with San Francisco Administrative Code Section 23.61. Tenant's failure to comply with its obligations under this Section shall constitute a material breach of this Lease. A Contractor's or Subcontractor's failure to comply with this Section will enable the City to seek the remedies specified in San Francisco Administrative Code Section 23.61 against the breaching party. For the current Prevailing Rate of Wages, see www.sfgov.org/olse or call the City's Office of Labor Standards Enforcement at 415-554-6235.

Tenant shall also pay, and shall require its subtenants, and Contractors and Subcontractors (regardless of tier) to pay, the Prevailing Rate of Wage for the following activities on the Premises as set forth in and to the extent required by San Francisco Administrative Code Chapter 21C: a Public Off-Street Parking Lot, Garage or Automobile Storage Facility (as defined in Section 21C.3), a Show (as defined in Section 21C.4), a Special Event (as defined in Section 21C.8), Broadcast Services (as defined in Section 21C.9), Commercial Vehicles, Loading and Unloading for Shows and Special Events (as defined in Section 21C.10), and Security Guard Services for Events (as defined in Section 21C.11).

6.4 Construction Insurance; Performance and Payment Bond

Prior to commencing the Tenant Improvement Work, Tenant shall comply with the insurance requirements in Section 19.1(b) below and, at least five (5) business days prior to commencing any of the Tenant Improvement Work, Tenant shall provide, at its sole cost and expense, to City (i) a corporate surety payment bond and a performance bond substantially in the form attached hereto as Exhibit F and obtained by each of Tenant's contractors performing any of the Tenant Improvement Work, or (ii) a financial guarantee, in a form approved by City in its sole discretion, from a third party with liquid assets in an amount of no less than one hundred twenty-five percent (125%) of the cost of the Tenant Improvement Work. Each bond shall be in an amount equal to one hundred percent (100%) of the estimated costs of the Tenant Improvement Work. Each performance bond shall guarantee the contractor's faithful performance of its contract(s) with Tenant. Each payment bond shall guarantee the contractor's payment of labor, materials, supplies and equipment used in the performance of its contract(s) with Tenant. The bonds are intended to help protect City against any liability for mechanics' and materialmen's liens, stop notices and to ensure completion of the work. Corporate sureties issuing these bonds shall be legally authorized to engage in the business of furnishing surety bonds in the State of California. All sureties shall have a current A.M. Best Rating of not less than A-, VIII. Each corporate surety bond shall obligate the surety to Tenant and the City and County of San Francisco as co-obligees.

6.5 Delay in Completion of Tenant Improvement Work

If City's Department of Building Inspection does not issue a temporary certificate of completion for the Tenant Improvements on or before (i) the eighteen (18) month anniversary of the Effective Date for any reason under Tenant's reasonable control, or (ii) the twenty-fourth (24th) month anniversary of the Effective Date for any reason, City shall have the right, at its sole election, to terminate this Lease by delivering written notice of such termination to Tenant at any time prior to such issuance of such temporary certificate of completion. If City timely delivers such termination notice to Tenant, the effective date of termination shall be the date specified in such notice.

7. ALTERATIONS

7.1 Tenant's Alterations

(a) General

Tenant shall not make or permit any alterations to the Building or to the heating, ventilating, air conditioning, plumbing, electrical, fire protection, life safety, security and other

mechanical, electrical, communications systems of the Building ("Building Systems"), and shall not make or permit any alterations, installations, additions or improvements, structural or otherwise (collectively, with the Tenant Improvements, "Alterations"), in, to or about the Premises, without City's prior written consent in each instance. All Alterations shall be done at Tenant's expense in accordance with plans and specifications approved by City, only by duly licensed and bonded contractors or mechanics approved by City, and subject to any conditions that City may reasonably impose, including, but not limited to, requiring a performance bond. with respect to the performance of such Alterations, requiring such contractors or mechanics to indemnify City with respect to Claims (as defined in Section 18.2) with respect to the Premises or such Alteration, and/or requiring the insurance described in Section 19.1(b). If any Alterations would be visible from the exterior of the Building, Tenant, shall obtain the prior written approval of City's Arts Commission to the extent the Arts Commission has jurisdiction over the design of such proposed alterations under City's Charter Section 5.103.

(b) Asbestos

Without limiting Section 26.2 (No Hazardous Materials) below, in the event that asbestos-containing materials ("ACM") are determined to exist in or about the Premises, Tenant shall ensure that all Alterations and any asbestos related work, as defined in California Health & Safety Code Section 25914.1(b), is performed in compliance with all laws relating to asbestos, including but not limited to California Occupational Safety and Health (OSHA) regulations found in Title 8 of the California Code of Regulations, Sections 1502 and 1529. Additionally, Tenant shall distribute notifications to all employees and contractors as required pursuant to California Health & Safety Code Section 25915 et seq. informing them of the existence of ACM and that moving, drilling, boring, or otherwise disturbing ACM may present a health risk and should not be attempted by an unqualified employee. No Alterations affecting ACM-containing areas or any asbestos related work shall be performed without City's prior written consent in each instance.

(c) Prevailing Wage and Local Hiring Requirements

Tenant and its subtenants shall comply with the applicable requirements of Section 6.2 (Local Hiring Requirements) and Section 6.3 (Prevailing Wages and Working Conditions) above in the performance of any Alterations.

(d) Tenant's Improvements or Alterations that Disturb or Remove Lead-Based Paint

Tenant, on behalf of itself and its Agents or Invitees, shall comply with all requirements of the San Francisco Building Code, Section 3407, and all other applicable present or future federal, state, local and administrative laws, rules, regulations, orders and other governmental requirements, the requirements of any board of fire underwriters or other similar body, any directive or occupancy certificate issued pursuant to any law by any public officer or officers acting in their regulatory capacity (collectively, "Laws"), including, without limitation, the California and United States Occupational Health and Safety Acts and their implementing regulations, when the work of improvement or alteration disturbs or removes exterior lead-based or "presumed" lead-based paint (as defined below). Tenant and its Agents or Invitees shall give to City three (3) business days' prior written notice of any disturbance or removal of exterior lead-based or presumed lead-based paint. Further, Tenant and its Agents or Invitees, when disturbing or removing exterior lead-based or presumed lead-based paint, shall not use or cause to be used any of the following methods: (a) acetylene or propane burning and torching; (b) scraping, sanding or grinding without containment barriers or a High Efficiency Particulate Air filter ("HEPA") local vacuum exhaust tool; (c) hydroblasting or high-pressure wash without containment barriers; (d) abrasive blasting or sandblasting without containment barriers or a HEPA vacuum exhaust tool; and (e) heat guns operating above 1,100 degrees Fahrenheit. Paint on the exterior of buildings built before December 31, 1978, is presumed to be lead-based paint

unless lead-based paint testing, as defined in Section 3407 of the San Francisco Building Code, demonstrates an absence of lead-based paint on the exterior surfaces of such buildings. Under this Section, lead-based paint is "disturbed or removed" if the work of improvement or alteration involves any action that creates friction, pressure, heat or a chemical reaction upon any lead-based or presumed lead-based paint on an exterior surface so as to abrade, loosen, penetrate, cut through or eliminate paint from that surface. Notice to City under this Lease shall not constitute notice to the City's Department of Building Inspection required under Section 3407 of the San Francisco Building Code.

(e) Design Principles

Tenant shall ensure the Tenant Improvement Work and all Alterations result in a creative and adaptive reuse of an existing space and shall design with Crime Prevention Through Environmental Design (CPTED) principles in mind. Whenever possible, Tenant's design decisions for the Tenant Improvement Work and any Alterations shall reflect those principles.

7.2 Title to Improvements

Except for Tenant's Personal Property or as may be specifically provided to the contrary in the approved Plans, all appurtenances, fixtures, improvements, equipment, additions, and other property attached or affixed to or installed in the Premises during the Term, including, without limitation, the Tenant Improvements and any Alterations, shall be and remain City's property. Tenant may not remove any such property at any time during or after the Term unless City so requests as further provided in Section 24 (Surrender of Premises) below.

7.3 Tenant's Personal Property

All furniture, trade fixtures, office equipment and articles of movable personal property installed in the Premises by or for the account of Tenant, without expense to City, and that can be removed without structural or other damage to the Premises (collectively, "Tenant's Personal Property") shall be and remain Tenant's property. Tenant may remove Tenant's Personal Property at any time during the Term, subject to the provisions of Section 24 (Surrender of Premises) below. Tenant shall pay any taxes or other impositions levied or assessed upon Tenant's Personal Property, at least ten (10) days prior to delinquency, and shall deliver satisfactory evidence of such payment to City upon request.

7.4 City's Alterations of the Building and Building Systems

City reserves the right at any time to make alterations, additions, repairs, deletions or improvements to any part of the Building or the Building Systems, provided that any such alterations or additions shall not materially adversely affect the functional utilization of the Premises for the uses permitted hereunder.

8. REPAIRS AND MAINTENANCE

8.1 City's Repairs

Except for providing the Fire and Alarm System Maintenance (as defined in Section 10.1), City shall have no obligation to repair and maintain any portion of the Premises, including, but not limited to, the structural or non-structural portions of the Building, any Building Systems and the sidewalks and curbs at the Premises, except to the extent damaged by any act or omission of Landlord or its Agents (as defined in Section 27.5 (Parties and Their Agents; Approvals) below) at the Premises or under this Lease. For the purpose of making any such repairs of damage caused by the act or omission of Landlord or its Agents, City may use structures in the Premises where reasonably required by the character of the work to be performed, provided that such work shall not unreasonably interfere with Tenant's business.

Tenant waives any claim for damages for any injury or inconvenience to or interference with Tenant's business, any loss of occupancy or quiet enjoyment of the Premises or any other loss occasioned thereby.

8.2 Tenant's Repairs

Tenant shall maintain, at no expense to City, the Premises (including, without limitation, the floors, roof, walls, exterior, interior, plumbing, electrical wiring, fixtures, and equipment) in good repair and working order and in a clean, secure, safe and sanitary condition. Tenant shall promptly make all repairs and replacements: **(a)** at no cost to the City, **(b)** by licensed contractors or qualified mechanics approved by City, **(c)** so that the same shall be at least equal in quality, value and utility to the original work or installation, **(d)** in a manner and using equipment and materials that will not interfere with or impair the operations, use or occupation of the Building or the Building Systems, and **(e)** in accordance with any applicable Building Rules and Regulations (as defined in Section 22 (Rules and Regulations)) and all applicable laws, rules and regulations. Notwithstanding the foregoing, Tenant shall not be required to correct any construction defects in the Building or the Premises in existence as of the Effective Date (an "Existing Defect"). If there is an Existing Defect that materially interferes with the Permitted Uses or threatens public health or safety, Tenant and City shall each have the right to terminate this Lease by delivering no less than thirty (30) days' written notice of such termination to the other party. Tenant hereby waives all rights to make repairs at City's expense under Sections 1941 and 1942 of the California Civil Code or under any similar law, statute or ordinance now or hereafter in effect.

9. LIENS AND ENCUMBRANCES

9.1 Liens

Tenant shall keep the Premises free from any liens arising out of any work performed, material furnished or obligations incurred by or for Tenant. In the event Tenant does not, within five (5) days following the imposition of any such lien, cause the lien to be released of record by payment or posting of a proper bond, City shall have, in addition to all other remedies, the right, but not the obligation, to cause the lien to be released by such means as it shall deem proper, including, but not limited to, payment of the claim giving rise to such lien. All such sums paid by City and all expenses incurred by it in connection therewith (including, without limitation, reasonable attorneys' fees) shall be payable to City by Tenant upon demand. City shall have the right to post on the Premises any notices that City may deem proper for the protection of City, the Premises, and the Building, from mechanics' and material supplier's liens. Tenant shall give to City at least fifteen (15) days' prior written notice of commencement of any Alteration, repair or construction on the Premises. Tenant agrees to indemnify, defend and hold City and its Agents harmless from and against any claims for mechanic's, material supplier's or other liens in connection with any Alterations, repairs or construction on the Premises, or materials furnished or obligations incurred by or for Tenant.

9.2 Encumbrances

Tenant shall not create, permit or suffer any liens or encumbrances affecting any portion of the Premises or City's interest therein or under this Lease.

10. UTILITIES AND SERVICES

10.1 Utilities and Services

City shall provide (i) the utilities described in the attached Exhibit G (the "Standard Utilities") to the Building, subject to the terms and conditions contained therein, and (ii) the basic Building fire sprinkler system and alarm system maintenance (the "Fire and Alarm System

Maintenance") described in the agreements listed in the attached Exhibit J (the "Maintenance Agreements"), subject to the terms and conditions contained therein. Tenant shall pay City, as additional rent, an amount equal to such the City's cost to provide the Standard Utilities and the Fire and Alarm System Maintenance within thirty (30) days of receiving City's invoice therefor. Any City failure to bill Tenant for such costs shall not impair City's right to bill Tenant for such costs at a later date.

Notwithstanding anything to the contrary in the foregoing paragraph, if Tenant reasonably determines the Building fire sprinkler system and/or alarm system must be improved to comply with any applicable laws or meet reasonable and applicable commercial standards, City shall have no obligation to provide Fire and Alarm System Maintenance to such system during the period it is being improved. Tenant shall deliver no less than thirty (30) days' prior written notice to City of any removal or improvement to the Building fire sprinkler system and Tenant shall coordinate with City's Fire and Alarm System Maintenance contractors as may be required in the Maintenance Agreements.

Tenant shall be responsible for furnishing, at Tenant's sole cost, any utilities or services other than or in excess of the Standard Utilities and Fire and Alarm System Maintenance that Tenant may need or desire for its use of the Premises, and for performing all necessary repairs or replacements to the Building fire sprinkler system and alarm system.

10.2 Water and Energy Conservation; Mandatory or Voluntary Restrictions

In the event any law, ordinance, code or governmental or regulatory guideline imposes mandatory or voluntary controls on City or the Premises or any part thereof, relating to the use or conservation of energy, water, gas, light or electricity or the reduction of automobile or other emissions, or the provision of any other utility or service provided with respect to this Lease, or in the event City is required or elects to make alterations to any part of the Building in order to comply with such mandatory or voluntary controls or guidelines, such compliance and the making of such alterations shall in no event entitle Tenant to any damages, relieve Tenant of the obligation to pay the full Base Rent, Percentage Rent, and Additional Charges reserved hereunder or to perform each of its other covenants hereunder or constitute or be construed as a constructive or other eviction of Tenant. City shall have the right at any time to install a water meter in the Premises or otherwise to measure the amount of water consumed on the Premises, and the cost of such meter or other corrective measures and the installation and maintenance thereof shall be paid for by Tenant.

10.3 Excess Use

Tenant shall not: (a) connect or use any apparatus, device or equipment that will impair the proper functioning or capacity of the Building Systems; or (b) connect any apparatus, device or equipment through electrical outlets except in the manner for which such outlets are designed and without the use of any device intended to increase the plug capacity of any electrical outlet; or (c) maintain at any time an electrical demand load in excess of any amount specified therefor in the Rules and Regulations. If at any time during the Term City has reason to believe that Tenant may be using any utility in excess of the amount therefor allowed to the Premises pursuant to the Standard Utilities, City shall have the right to install a separate meter in the Premises or to take other appropriate steps to measure the amount of utility or service used in the Premises, and the cost of such meter and all corrective measures, and the installation and maintenance thereof, shall be paid for by Tenant.

10.4 Floor Load

Without City's prior written consent, which City may give or refuse in its sole discretion, Tenant shall not place or install in the Building any equipment that weighs in excess of the normal load-bearing capacity of the floors of the Building. If City consents to the placement or

installation of any such machine or equipment in the Building, Tenant, at no cost to the City, shall reinforce the floor of the Building, pursuant to plans and specifications approved by City and otherwise in compliance with Section 7.1 (Tenant's Alterations), to the extent necessary to assure that no damage to the Building or weakening of any structural supports will be occasioned thereby.

10.5 Interruption of Services

City's obligation to provide the Standard Utilities and Fire and Alarm System Maintenance for the Premises are subject to the Rules and Regulations of the Building, applicable Legal Requirements (as defined below) (including the rules or actions of the public utility company furnishing the utility or service), and shutdowns for maintenance and repairs, for security purposes, or due to strikes, lockouts, labor disputes, fire or other casualty, acts of God, or other causes beyond the control of City. In the event of an interruption in, or failure or inability to provide any service or utility for the Premises for any reason, such interruption, failure or inability shall not constitute an eviction of Tenant, constructive or otherwise, or impose upon City any liability whatsoever, including, but not limited to, liability for consequential damages or loss of business by Tenant; provided, however, that if such interruption, failure or inability impairs Tenant's ability to carry on its business in the Premises for a period of five (5) or more consecutive business days, then Tenant shall have the right, as Tenant's sole remedy, to abate the Rent based on the extent such interruption, failure or inability impairs Tenant's ability to carry on its business in the Premises. Tenant hereby waives the provisions of California Civil Code Section 1932(1) or any other applicable existing or future Legal Requirement permitting the termination of this Lease due to such interruption, failure or inability.

11. COMPLIANCE WITH LAWS AND RISK MANAGEMENT REQUIREMENTS

11.1 Compliance with Laws

Tenant shall promptly comply, at no cost to the City, with all present or future laws, ordinance, resolution, regulation, requirement, proclamation, order or decree of any municipal, county, state or federal government or other governmental or regulatory authority relating to the Premises or the use or occupancy thereof (the "Legal Requirements") and with any and all recorded covenants, conditions and restrictions affecting the Premises or any portion thereof, whether in effect at the time of the execution of this Lease or adopted or recorded at any time thereafter and whether or not within the present contemplation of the parties. Tenant further understands and agrees that it is Tenant's obligation, at no cost to the City, to cause the Premises and Tenant's uses thereof to be conducted in compliance with the Americans with Disabilities Act, 42 U.S.C. Section 12101 et seq. and any other applicable disability access laws. Tenant shall not be required to make any structural Alterations or Alterations to the Building Systems in order to comply with such laws unless such Alterations shall be occasioned, in whole or in part, directly or indirectly, by the Tenant Improvements or any other Alterations, Tenant's use of the Premises, or any act or omission of Tenant, its Agents or Invitees. Any Alteration made by or on behalf of Tenant pursuant to the provisions of this Section shall comply with the provisions of Section 8.2 (Tenant's Repairs) above. The parties acknowledge and agree that Tenant's obligation to comply with all Legal Requirements as provided herein is a material part of the bargained for consideration under this Lease. Tenant's obligation under this Section shall include, when applicable and without limitation, the responsibility of Tenant to make substantial or structural repairs and Alterations to the Premises (including any of the Tenant Improvements or any of Tenant's Alterations), regardless of, among other factors, the relationship of the cost of curative action to the Rent under this Lease, the length of the then remaining Term hereof, the relative benefit of the repairs to Tenant or City, the degree to which the curative action may interfere with Tenant's use or enjoyment of the Premises, the likelihood that the parties contemplated the particular Legal Requirement involved, and whether the Legal Requirement involved is related to Tenant's particular use of the Premises.

11.2 Regulatory Approvals

(a) Responsible Party

Tenant understands and agrees that Tenant's use of the Premises and construction of the Tenant Improvements permitted hereunder may require authorizations, approvals or permits from governmental regulatory agencies with jurisdiction over the Premises, including, without limitation, City agencies. Tenant shall be solely responsible for obtaining any and all such regulatory approvals. Tenant shall not seek any regulatory approval without first obtaining the written consent of City under this Lease. Tenant shall bear all costs associated with applying for and obtaining any necessary or appropriate regulatory approval and shall be solely responsible for satisfying any and all conditions imposed by regulatory agencies as part of a regulatory approval; provided, however, any such condition that could affect use or occupancy of the Premises or City's interest therein must first be approved by City in its sole discretion. Any fines or penalties levied as a result of Tenant's failure to comply with the terms and conditions of any regulatory approval shall be immediately paid and discharged by Tenant, and City shall have no liability, monetary or otherwise, for any such fines or penalties. Tenant shall Indemnify City and the other Indemnified Parties (as such terms are defined in Section 18.2 (Tenant's Indemnity) below) hereunder against all Claims arising in connection with Tenant's failure to obtain or failure by Tenant, its Agents or Invitees to comply with the terms and conditions of any regulatory approval.

(b) City Acting as Owner of Real Property

Tenant further understands and agrees that City is entering into this Lease in its capacity as a property owner with a proprietary interest in the Premises and not as a regulatory agency with police powers. Nothing in this Lease shall limit in any way Tenant's obligation to obtain any required approvals from City officials, departments, boards or commissions having jurisdiction over the Premises. By entering into this Lease, City is in no way modifying or limiting Tenant's obligation to cause the Premises to be used and occupied in accordance with all applicable laws, as provided further above.

11.3 Compliance with City's Risk Management Requirements

Tenant shall not do anything, or permit anything to be done, in or about the Premises which would be prohibited by or increase rates under a standard form fire insurance policy or subject City to potential premises liability. Tenant shall faithfully observe, at no cost to the City, any and all requirements of City's Risk Manager with respect to Tenant's use and occupancy of the Premises, so long as such requirements do not unreasonably interfere with Tenant's use of the Premises or are otherwise connected with standard prudent commercial practices of other landlords.

12. SUBORDINATION

This Lease is and shall be subordinate to the Access Easements and any other easements, ground lease, facilities lease or other underlying lease and the lien of any mortgage or deed of trust and all renewals, modifications, consolidations, replacements and extensions of any of the foregoing, that may now exist or hereafter be executed by City affecting the Premises, or any part thereof or City's interest therein (each, a "Priority Document"), without the necessity of executing any instrument to effectuate such subordination if such Priority Document is executed before the Effective Date. Tenant shall subordinate this Lease to any Priority Document executed after the Effective Date if Tenant receives a commercially reasonable non-disturbance agreement with respect to such Priority Document. Upon City's request, Tenant, or Tenant's successor-in-interest, shall execute and deliver any and all instruments desired by City evidencing the subordination of this Lease to any Priority Document pursuant to this Section in the manner requested by City. Notwithstanding the foregoing, City or the holder of a Priority

Document shall, in its respective discretion, have the right to subordinate any such interests to this Lease. If any ground lease or underlying lease terminates for any reason or any mortgage or deed of trust is foreclosed or a conveyance in lieu of foreclosure is made for any reason, Tenant shall attorn to the successor-in-interest to City, at the option of such successor-in-interest. The provisions of this Section shall be self-operative and no further instrument shall be required except as otherwise expressly set forth in this Section. Tenant agrees, however, to execute and deliver, upon demand by City and in the form requested by City, any additional documents evidencing the priority or subordination of this Lease (subject to Tenant's receipt of a commercially reasonable non-disturbance agreement with respect to the subordination to any Priority Documents executed after the Effective Date).

13. INABILITY TO PERFORM

No actual or constructive eviction, in whole or in part, shall entitle Tenant to any abatement or diminution of Rent or relieve Tenant from any of its obligations under this Lease. If City is unable to perform or is delayed in performing any of City's obligations under this Lease, by reason of acts of God, accidents, breakage, repairs, strikes, lockouts, other labor disputes, protests, riots, demonstrations, inability to obtain utilities or materials or by any other reason beyond City's reasonable control, no such inability or delay shall constitute an eviction under this Lease, or impose any liability upon City or its Agents by reason of inconvenience, annoyance, interruption, injury or loss to or interference with Tenant's business or use and occupancy or quiet enjoyment of the Premises or any loss or damage occasioned thereby. Tenant hereby waives and releases any right to terminate this Lease under Section 1932, subdivision 1 of the California Civil Code or any similar law, statute or ordinance now or hereafter in effect.

14. DAMAGE AND DESTRUCTION

14.1 Damage and Destruction

If the Premises or the Building is damaged by fire or other casualty, then City shall repair the same provided that funds for such repairs are appropriated by City's Board of Supervisors, in its sole discretion, for such purpose and that such repairs can be made within two hundred ten (210) days after the date of such damage (the "Repair Period"). In the event such conditions are satisfied, this Lease shall remain in full force and effect except that Tenant shall be entitled to a proportionate reduction of Base Rent during the period of such repairs based upon the extent to which such damage and the making of such repairs materially interferes with Tenant's use or occupancy of the Premises.

City shall use reasonable efforts to notify Tenant within ninety (90) days after the date of such damage whether or not such repairs can be made within the Repair Period, and City's determination thereof shall be binding on Tenant. If such repairs cannot be made within the Repair Period, City shall have the option to notify Tenant of: (a) City's intention to repair such damage and diligently prosecute such repairs to completion within a reasonable period after the Repair Period, subject to the Board of Supervisor's appropriation of all necessary funds, in which event this Lease shall continue in full force and effect and the Base Rent shall be reduced as provided herein; or (b) City's election to terminate this Lease as of a date specified in such notice, which date shall be not less than thirty (30) nor more than sixty (60) days after notice is given by City. In case of termination, the Base Rent shall be reduced as provided above, and Tenant shall pay such reduced Base Rent up to the date of termination.

If at any time during the last twelve (12) months of the Term of this Lease, the Premises or the Building is damaged in a manner that cannot be repaired within sixty (60) days or destroyed, then either City or Tenant may terminate this Lease by giving written notice to the other party of its election to do so within thirty (30) days after the date of the occurrence of such damage; provided, however, Tenant may terminate only if such damage or destruction substantially impairs its use or occupancy of the Premises for the uses permitted hereunder. The

effective date of termination shall be specified in the notice of termination, which date shall not be more than thirty (30) days from the date of the notice.

Notwithstanding anything to the contrary in this Lease, City shall have no obligation to repair the Premises or the Building in the event the damage or destruction is attributable to any act or omission of Tenant, its Agents or Invitees. In no event shall City be required to repair any damage to Tenant's Personal Property or any paneling, decorations, railings, floor coverings, or any Tenant Improvements or Alterations installed or made on the Premises by or at the expense of Tenant. In the event the Premises or the Building is substantially damaged or destroyed and City intends to rebuild for public purposes inconsistent with this Lease, City may terminate this Lease upon written notice to Tenant.

14.2 Waiver

City and Tenant intend that the provisions of this Section govern fully in the event of any damage or destruction and accordingly, City and Tenant each hereby waives the provisions of Section 1932, subdivision 2, Section 1933, subdivision 4 and Sections 1941 and 1942, of the Civil Code of California or under any similar law, statute or ordinance now or hereafter in effect.

15. EMINENT DOMAIN

15.1 Definitions

(a) "Taking" means a taking or damaging, including severance damage, by eminent domain, inverse condemnation or for any public or quasi-public use under law. A Taking may occur pursuant to the recording of a final order of condemnation, or by voluntary sale or conveyance in lieu of condemnation or in settlement of a condemnation action.

(b) "Date of Taking" means the earlier of (i) the date upon which title to the portion of the Premises taken passes to and vests in the condemnor or (ii) the date on which Tenant is dispossessed.

(c) "Award" means all compensation, sums or anything of value paid, awarded or received for a Taking, whether pursuant to judgment, agreement, settlement or otherwise.

(d) "Improvements Pertaining to the Realty" means machinery or equipment installed for use on the Premises that cannot be removed without a substantial economic loss or without substantial damage to the property on which it is installed, regardless of the method of installation. In determining whether particular property can be removed "without a substantial economic loss," the value of the machinery or equipment in place and considered as part of the realty should be compared with its value if it were removed and sold.

15.2 General

If during the Term there is any Taking of all or any part of the Premises or any interest in this Lease, the rights and obligations of the parties hereunder shall be determined pursuant to this Section. City and Tenant intend that the provisions hereof govern fully in the event of a Taking and accordingly, the parties each hereby waive any right to terminate this Lease in whole or in part under Sections 1265.110, 1265.120, 1265.130 and 1265.140 of the California Code of Civil Procedure or under any similar law now or hereafter in effect.

15.3 Total Taking; Automatic Termination

If there is a total Taking of the Premises, then this Lease shall terminate as of the Date of Taking.

15.4 Partial Taking; Election to Terminate

(a) If there is a Taking of any portion (but less than all) of the Premises, then this Lease shall terminate in its entirety under either of the following circumstances: (i) if all of the following exist: (A) the partial Taking renders the remaining portion of the Premises untenable or unsuitable for continued use by Tenant, (B) the condition rendering the Premises untenable or unsuitable either is not curable or is curable but City is unwilling or unable to cure such condition, and (C) Tenant elects to terminate; or (ii) if City elects to terminate; provided, however, that this Lease shall not terminate if Tenant agrees to, and does, pay full Rent and Additional Charges, without abatement, and otherwise agrees to, and does, fully perform all of its obligations hereunder.

(b) If there is a partial Taking of a substantial portion of the Building but not the Premises, City shall have the right to terminate this Lease in its entirety.

(c) Either party electing to terminate under the provisions of this Section 15 shall do so by giving the other party written notice to the other party before or within thirty (30) days after the Date of Taking, and thereafter this Lease shall terminate upon the later of the thirtieth (30th) day after such written notice is given or the Date of Taking.

15.5 Termination of Lease; Rent and Award

Upon termination of this Lease in its entirety pursuant to Section 15.3 (Total Taking; Automatic Termination), or pursuant to an election under Section 15.4 (Partial Taking, Election to Terminate) above, then: (a) Tenant's obligation to pay Rent shall continue up until the date of termination and thereafter shall cease, and (b) City shall be entitled to the entire Award in connection therewith (including, but not limited to, any portion of the Award made for the value of the leasehold estate created by this Lease and any Improvements Pertaining to the Realty), and Tenant shall have no claim against City for the value of any unexpired term of this Lease, provided that Tenant may make a separate claim for compensation, and Tenant shall receive any Award made specifically to Tenant, for Tenant's relocation expenses or the interruption of or damage to Tenant's business or damage to movable Tenant's Personal Property.

15.6 Partial Taking; Continuation of Lease

If there is a partial Taking of the Premises under circumstances where this Lease is not terminated in its entirety under Section 15.4 (Partial Taking; Election to Terminate) above, then this Lease shall terminate as to the portion of the Premises so taken, but shall remain in full force and effect as to the portion not taken, and the rights and obligations of the parties shall be as follows: (a) Base Rent shall be reduced by an amount that is in the same ratio to the Base Rent as the area of the Premises taken bears to the area of the Premises prior to the Date of Taking; provided, however, in no event shall the monthly Base Rent be reduced to less than seventy-five percent (75%) of the monthly Base Rent immediately prior to the Date of Taking, and (b) City shall be entitled to the entire Award in connection therewith (including, but not limited to, any portion of the Award made for the value of the leasehold estate created by this Lease), and Tenant shall have no claim against City for the value of any unexpired term of this Lease, provided that Tenant may make a separate claim for compensation, and Tenant shall receive any Award made specifically to Tenant, for Tenant's relocation expenses or the interruption of or damage to Tenant's business or damage to movable Tenant's Personal Property.

15.7 Temporary Takings

Notwithstanding anything to contrary in this Section, if a Taking occurs with respect to all or any part of the Premises for a limited period of time not in excess of one hundred eighty (180) consecutive days, this Lease shall remain unaffected thereby, and Tenant shall continue to pay Rent and to perform all of the terms, conditions and covenants of this Lease. In the event of

such temporary Taking, Tenant shall be entitled to receive that portion of any Award representing compensation for the use or occupancy of the Premises during the Term up to the total Rent owing by Tenant for the period of the Taking, and City shall be entitled to receive the balance of any Award.

16. ASSIGNMENT AND SUBLETTING

16.1 Restriction on Assignment and Subletting

Except as otherwise set forth in the following paragraph, Tenant shall not directly or indirectly (including, without limitation, by merger, acquisition or other transfer of any controlling interest in Tenant), voluntarily or by operation of law, sell, assign, encumber, pledge or otherwise transfer any part of its interest in or rights with respect to the Premises or its leasehold estate hereunder (collectively, an "Assignment"), or permit or license any portion of the Premises to be used or occupied by anyone other than itself, or sublet any portion of the Premises (collectively, "Sublease"), without City's prior written consent in each instance, as provided hereinbelow.

Tenant shall have the right to enter into an Assignment or Sublease without obtaining the consent of City to any Tenant's Affiliate (as defined below), provided Tenant gives City written notice of its intent thereof at least fifteen (15) business days before the proposed effective date of such transfer. In addition, City acknowledges that Tenant's intended use of the Premises is as a market hall with multiple small vendors that cultivates low-income food entrepreneurs. Accordingly, Tenant shall have the right to Sublease any or all portions of the Premises to vendors (each, a "Vendor") without obtaining the consent of City; provided, however, that Tenant shall use commercially reasonable efforts to select Vendors that are low-income, local businesses, and shall charge commercially reasonable rates to Vendors that are reasonably capable of paying them.

As used in this Section, the term "Tenant's Affiliate" shall mean, any of the following: (a) any person or entity owning, directly or indirectly, fifty percent (50%) or more of the ownership interests of Tenant (an "Owning Person"), (b) any entity, fifty percent (50%) or more of the ownership interests of which are owned, directly or indirectly, by any Owning Person, (c) any entity, fifty percent (50%) or more of the ownership interests of which are owned, directly or indirectly, by Tenant.

16.2 Notice of Proposed Transfer

If Tenant desires to enter into an Assignment or a Sublease that requires City's consent pursuant to Section 16.1 above, it shall give written notice (a "Notice of Proposed Transfer") to City of its intention to do so. The Notice of Proposed Transfer shall identify the proposed transferee and state the terms and conditions of the proposed Assignment or Sublease. Tenant shall deliver to City with its request for City's consent the proposed Assignment or Sublease and current financial statements of the proposed transferee, prepared by an independent certified public accountant, and promptly upon City's request for same, any additional documents or information reasonably related to the proposed transaction or transferee.

16.3 City's Response

Within twenty (20) business days after City's receipt of the Notice of Proposed Transfer (the "Response Period"), City may elect, by written notice to Tenant, to: (a) sublease the portion of the Premises specified in the Notice of Proposed Transfer on the terms and conditions set forth in such notice, except as otherwise provided in Section 16.4 (Sublease or Recapture Space), or (b) terminate this Lease as to the portion (including all) of the Premises that is specified in the Notice of Proposed Transfer, with a proportionate reduction in Base Rent (a "Recapture").

If City declines to exercise either of its options provided above, then Tenant shall have ninety (90) days following the earlier of (i) City's notice that it will not elect either such option or (ii) the expiration of the Response Period, to enter into such Assignment or Sublease, subject to City's prior written approval of the proposed assignee or subtenant (each, a "Transferee") and the terms and conditions of the proposed Sublease or Assignment. However, one hundred percent (100%) of any rent or other consideration realized by Tenant under any such Assignment or Sublease in excess of the Base Rent and Additional Charges payable hereunder (or the amount thereof proportionate to the portion of the Premises subject to such Sublease or Recapture) shall be paid to City, after Tenant has recovered any reasonable brokers' commissions and the reasonable cost of any leasehold improvements that Tenant has incurred in connection with such Sublease or Recapture. Tenant shall provide City with such information regarding the proposed Transferee and the Assignment or Sublease as City may reasonably request. City agrees that it will not unreasonably withhold its approval of any proposed Transferee.

If after City declines to exercise any of the foregoing options Tenant desires to enter into such Assignment or Sublease (A) on terms and conditions materially more favorable to Tenant than those contained in the Notice of Proposed Transfer or (B) with a Transferee that is currently a tenant or other occupant of the Building, then Tenant shall give City a new Notice of Proposed Transfer, which notice shall state the terms and conditions of such Assignment or Sublease and identify the proposed Transferee, and City shall again be entitled to elect one of the options provided in clauses (a) and (b) at any time within twenty (20) business days after City's receipt of such new Notice of Proposed Transfer.

In the event City elects either of the options provided in clauses (a) or (b), City shall be entitled to enter into a lease, sublease or assignment agreement with respect to the Premises (or portion thereof specified in such new Notice of Proposed Transfer) with the proposed Transferee identified in Tenant's notice.

Notwithstanding the foregoing, if any event of default by Tenant is outstanding hereunder at the time of Tenant's Notice of Proposed Transfer (or if any event shall have occurred which with the giving of notice or the passage of time or both would constitute such a default), then City may elect by notice to Tenant to refuse to consent to Tenant's proposed Transfer and pursue any of its right or remedies hereunder or at law or in equity.

16.4 Sublease or Recapture Space

If City elects to Sublease or Recapture from Tenant as described in Section 16.3 (City's Response) the following shall apply:

(a) In the case of a Sublease, (i) City shall have the right to use the portion of the Premises covered by the Notice of Proposed Transfer (the "Sublease Space") for any legal purpose, (ii) the rent payable by City to Tenant shall be the lesser of (A) the amount in the Notice of Proposed Transfer or (B) the Base Rent payable by Tenant under this Lease at the time of the Sublease (or the amount thereof proportionate to the Sublease Space if for less than the entire Premises), (iii) City may make alterations and improvements to the Sublease Space and may remove any such alterations or improvements, in whole or in part, prior to or upon the expiration of the Sublease, provided that City shall repair any damage or injury to the Sublease Space caused by such removal, (iv) City shall have the right to further sublease or assign the Sublease Space to any party, without the consent of Tenant, and (v) Tenant shall pay to City on demand any costs incurred by City in physically separating the Sublease Space (if less than the entire Premises) from the balance of the Premises and in complying with any applicable laws or regulations relating to such separation.

(b) In the case of Recapture, (i) the portion of the Premises subject to the Recapture (the "Recapture Space") shall be deleted from the Premises for all purposes hereunder, and Tenant and City shall be relieved of all their rights and obligations hereunder with respect to

the Recapture Space except to the extent the same would survive the Expiration Date or other termination of this Lease pursuant to the provisions hereof, and (ii) City shall pay any cost incurred in physically separating the Recapture Space (if less than the entire Premises) from the balance of the Premises and in complying with any applicable governmental laws or regulations relating to such separation.

16.5 Effect of Sublease or Assignment

No Sublease or Assignment by Tenant nor any consent by City thereto shall relieve Tenant, or any guarantor, of any obligation to be performed by Tenant under this Lease. Any Sublease or Assignment not in compliance with this Section shall be void and, at City's option, shall constitute a material default by Tenant under this Lease. The acceptance of any Rent or other payments by City from a proposed Transferee shall not constitute consent to such Sublease or Assignment by City or a recognition of any Transferee, or a waiver by City of any failure of Tenant or other transferor to comply with this Section. If there is an Assignment or Sublease, whether in violation of or in compliance with this Section, in the event of default by any Transferee, Tenant's Affiliate, Vendor, or any successor of Tenant, in the performance or observance of any of the terms of this Lease or any Sublease or Assignment agreement, City may proceed directly against Tenant without the necessity of exhausting remedies against such Transferee, Tenant's Affiliate, Vendor, or successor.

16.6 Assumption by Transferee

Each Transferee (other than City), Tenant's Affiliate, and Vendor shall assume all obligations of Tenant under this Lease and shall be liable jointly and severally with Tenant for the payment of the Base Rent, Percentage Rent, and Additional Charges, and for the performance of all the terms, covenants and conditions to be performed on Tenant's part hereunder. No Assignment shall be binding on City unless Tenant or Transferee has delivered to City a counterpart of the Assignment and an instrument in recordable form that contains a covenant of assumption by such Transferee satisfactory in form and substance to City. However, the failure or refusal of such Transferee to execute such instrument of assumption shall not release such Transferee from its liability as set forth above. Tenant shall reimburse City on demand for any reasonable costs that may be incurred by City in connection with any proposed Sublease or Assignment, including, without limitation, the costs of making investigations as to the acceptability of the proposed Transferee and legal costs incurred in connection with the granting of any requested consent.

16.7 Indemnity for Relocation Benefits

Without limiting Section 16.6 (Assumption by Transferee) above, Tenant shall cause any Transferee, Tenant's Affiliate, and Vendor to expressly waive entitlement to any and all relocation assistance and benefits in connection with this Lease. Tenant shall Indemnify City for any and all Losses arising out of any relocation assistance or benefits payable to any Transferee, Tenant's Affiliate, or Vendor.

17. DEFAULT; REMEDIES

17.1 Events of Default

Any of the following shall constitute an event of default (the "Event of Default") by Tenant hereunder:

(a) a failure to pay Base Rent, Percentage Rent or Additional Charges when due, and such failure continues for three (3) days after the date of written notice by City. However, City shall not be required to provide such notice more than twice during any twelve (12)-month period, and any such failure by Tenant after Tenant has received two (2) such notices

in such twelve (12)-month period shall constitute a default by Tenant hereunder without any further action by City or opportunity of Tenant to cure except as may be required by Section 1161 of the California Code of Civil Procedure;

(b) a failure to comply with any other covenant, condition or representation made under this Lease and such failure continues for fifteen (15) days after the date of written notice by City, provided that if such default is not capable of cure within such fifteen (15)-day period, Tenant shall have a reasonable period to complete such cure if Tenant promptly undertakes action to cure such default within such fifteen (15)-day period and thereafter diligently prosecutes the same to completion within sixty (60) days after the receipt of notice of default from City. City shall not be required to provide such notice more than twice in any twelve (12)-month period with respect to any material non-monetary defaults and after the second notice in any calendar year, any subsequent failure by Tenant during such twelve (12)-month period shall constitute an Event of Default hereunder;

(c) a vacation or abandonment of the Premises for a continuous period in excess of five (5) business days; or

(d) an appointment of a receiver to take possession of all or substantially all of the assets of Tenant, or an assignment by Tenant for the benefit of creditors, or any action taken or suffered by Tenant under any insolvency, bankruptcy, reorganization, moratorium or other debtor relief act or statute, whether now existing or hereafter amended or enacted, if any such receiver, assignment or action is not released, discharged, dismissed or vacated within sixty (60) days.

17.2 Remedies

Upon the occurrence of an Event of Default City shall have the following remedies, which shall not be exclusive but shall be cumulative and shall be in addition to any other remedies now or hereafter allowed by law or in equity:

(a) City may terminate Tenant's right to possession of the Premises at any time by written notice to Tenant. Tenant expressly acknowledges that in the absence of such written notice from City, no other act of City, including, but not limited to, its re-entry into the Premises, its efforts to relet the Premises, its reletting of the Premises for Tenant's account, its storage of Tenant's Personal Property and trade fixtures, its acceptance of keys to the Premises from Tenant, its appointment of a receiver, or its exercise of any other rights and remedies under this Section 17.2 or otherwise at law, shall constitute an acceptance of Tenant's surrender of the Premises or constitute a termination of this Lease or of Tenant's right to possession of the Premises.

Upon such termination in writing of Tenant's right to possession of the Premises, this Lease shall terminate and City shall be entitled to recover damages from Tenant as provided in California Civil Code Section 1951.2 or any other applicable existing or future Legal Requirement providing for recovery of damages for such breach, including but not limited to the following:

(i) The reasonable cost of recovering the Premises; plus

(ii) The reasonable cost of removing Tenant's Alterations, trade fixtures and improvements; plus

(iii) All unpaid rent due or earned hereunder prior to the date of termination, less the proceeds of any reletting or any rental received from subtenants prior to the date of termination applied as provided in Section 17.2(b) below, together with interest at the

Interest Rate, on such sums from the date such rent is due and payable until the date of the award of damages; plus

(iv) The amount by which the rent which would be payable by Tenant hereunder, including Additional Charges under Section 4.3 (Additional Charges) above, as reasonably estimated by City, from the date of termination until the date of the award of damages, exceeds the amount of such rental loss as Tenant proves could have been reasonably avoided, together with interest at the Interest Rate on such sums from the date such rent is due and payable until the date of the award of damages; plus

(v) The amount by which the rent which would be payable by Tenant hereunder, including Additional Charges under Section 4.3 (Additional Charges) above, as reasonably estimated by City, for the remainder of the then term, after the date of the award of damages exceeds the amount such rental loss as Tenant proves could have been reasonably avoided, discounted at the discount rate published by the Federal Reserve bank of San Francisco for member banks at the time of the award plus one percent (1%); plus

(vi) Such other amounts in addition to or in lieu of the foregoing as may be permitted from time to time by applicable law, including without limitation any other amount necessary to compensate City for all the detriment proximately caused by Tenant's failure to perform its obligations under this Lease which in the ordinary course of things would be likely to result therefrom.

(b) City has the remedy described in California Civil Code Section 1951.4 (a landlord may continue the lease in effect after the tenant's breach and abandonment and recover rent as it becomes due, if the tenant has the right to sublet and assign subject only to reasonable limitations), and may continue this Lease in full force and effect and may enforce all of its rights and remedies under this Lease, including, but not limited to, the right to recover rent as it becomes due. After the occurrence of an Event of Default, City may enter the Premises without terminating this Lease and sublet all or any part of the Premises for Tenant's account to any person, for such term (which may be a period beyond the remaining term of this Lease), at such rents and on such other terms and conditions as City deems advisable. In the event of any such subletting, rents received by City from such subletting shall be applied (i) first, to the payment of the costs of maintaining, preserving, altering and preparing the Premises for subletting, the other costs of subletting, including but not limited to brokers' commissions, attorneys' fees and expenses of removal of Tenant's Personal Property, trade fixtures and Alterations; (ii) second, to the payment of rent then due and payable hereunder; (iii) third, to the payment of future rent as the same may become due and payable hereunder; and (iv) fourth, the balance, if any, shall be paid to Tenant upon (but not before) expiration of the term of this Lease. If the rents received by City from such subletting, after application as provided above, are insufficient in any month to pay the rent due and payable hereunder for such month, Tenant shall pay such deficiency to City monthly upon demand. Notwithstanding any such subletting for Tenant's account without termination, City may at any time thereafter, by written notice to Tenant, elect to terminate this Lease by virtue of a previous Event of Default.

During the continuance of an Event of Default, for so long as City does not terminate Tenant's right to possession of the Premises and subject to Section 16 (Assignment and Subletting) and the options granted to City thereunder, City shall not unreasonably withhold its consent to an assignment or sublease of Tenant's interest in the Premises or in this Lease.

(c) During the continuance of an Event of Default, City may enter the Premises without terminating this Lease and remove all Tenant's Personal Property, Alterations and trade fixtures from the Premises and store them at Tenant's risk and expense. If City removes such property from the Premises and stores it at Tenant's risk and expense, and if Tenant fails to pay the cost of such removal and storage after written demand therefor and/or to pay any rent then due, then after the property has been stored for a period of thirty (30) days or

more City may sell such property at public or private sale, in the manner and at such times and places as City deems commercially reasonable following reasonable notice to Tenant of the time and place of such sale. The proceeds of any such sale shall be applied first to the payment of the expenses for removal and storage of the property, the preparation for and the conducting of such sale, and for attorneys' fees and other legal expenses incurred by City in connection therewith, and the balance shall be applied as provided in Section 17.2(b) above.

Tenant hereby waives all claims for damages that may be caused by City's reentering and taking possession of the Premises or removing and storing Tenant's Personal Property pursuant to this Section 17.2, and Tenant shall indemnify, defend and hold City harmless from and against any and all Claims resulting from any such act. No reentry by City shall constitute or be construed as a forcible entry by City.

(d) City may require Tenant to remove any and all Alterations from the Premises or, if Tenant fails to do so within ten (10) days after City's request, City may do so at Tenant's expense.

(e) City may cure the Event of Default at Tenant's expense, it being understood that such performance shall not waive or cure the subject Event of Default. If City pays any sum or incurs any expense in curing the Event of Default, Tenant shall reimburse City upon demand for the amount of such payment or expense with interest at the Interest Rate from the date the sum is paid or the expense is incurred until City is reimbursed by Tenant. Any amount due City under this subsection shall constitute additional rent hereunder.

17.3 Waiver of Redemption

Tenant hereby waives, for itself and all persons claiming by and under Tenant, all rights and privileges which it might have under any present or future Legal Requirement to redeem the Premises or to continue this Lease after being dispossessed or ejected from the Premises.

17.4 City's Right to Cure Tenant's Defaults

If Tenant defaults in the performance of any of its obligations under this Lease, then City may, at its sole option, remedy such default for Tenant's account and at Tenant's expense by providing Tenant with three (3) days' prior written or oral notice of City's intention to cure such default (except that no such prior notice shall be required in the event of an emergency as determined by City). Such action by City shall not be construed as a waiver of such default or any rights or remedies of City, and nothing herein shall imply any duty of City to do any act that Tenant is obligated to perform. Tenant shall pay to City upon demand, as additional rent, all costs, damages, expenses or liabilities incurred by City, including, without limitation, reasonable attorneys' fees, in remedying or attempting to remedy such default. Tenant's obligations under this Section shall survive the termination of this Lease.

17.5 Reimbursement of Allowance

If Tenant fails to fully cure an Event of Default under Section 17.1(a) or Section 17.1(b), Tenant shall reimburse the Allowance to City within thirty (30) days of receiving City's written demand for such reimbursement.

18. WAIVER OF CLAIMS; INDEMNIFICATION

18.1 Limitation on City's Liability; Waiver of Claims

City shall not be responsible for or liable to Tenant, and Tenant hereby assumes the risk of, and waives and releases City and its Agents from all Claims for, any injury, loss or damage to any person or property in or about the Premises by or from any cause whatsoever including,

without limitation, (a) any act or omission of persons occupying adjoining premises or any part of the Building adjacent to or connected with the Premises, (b) theft, (c) explosion, fire, steam, oil, electricity, water, gas or rain, pollution or contamination, (d) stopped, leaking or defective Building Systems, (e) Building defects, and (f) any other acts, omissions or causes. Nothing in this Section shall relieve City from liability caused solely and directly by the gross negligence or willful misconduct of City or its Agents, but City shall not be liable under any circumstances for any consequential, incidental or punitive damages.

18.2 Tenant's Indemnity

Tenant, on behalf of itself and its successors and assigns, shall indemnify, defend and hold harmless ("Indemnify") City including, but not limited to, all of its boards, commissions, departments, agencies and other subdivisions, including, without limitation, its Real Estate Division, OEWD, Mayor's Office of Housing and Community Development, and all of its and their Agents, and their respective heirs, legal representatives, successors and assigns (individually, an "Indemnified Party" and collectively, the "Indemnified Parties"), and each of them, from and against any and all liabilities, losses, costs, claims, judgments, settlements, damages, liens, fines, penalties and expenses, including, without limitation, direct and vicarious liability of every kind (collectively, "Claims"), incurred in connection with or arising in whole or in part from: (a) any accident, injury to or death of a person, including, without limitation, employees of Tenant, or loss of or damage to property, howsoever or by whomsoever caused, occurring in or about the Premises; (b) any default by Tenant in the observation or performance of any of the terms, covenants or conditions of this Lease to be observed or performed on Tenant's part; (c) the use or occupancy or manner of use or occupancy of the Premises by Tenant, its Agents or Invitees or any person or entity claiming through or under any of them; (d) the condition of the Premises from and after the Effective Date; (e) any construction or other work undertaken by Tenant on the Premises whether before or during the Term of this Lease; or (f) any acts, omissions or negligence of Tenant, its Agents or Invitees, in, on or about the Premises, all regardless of the active or passive negligence of, and regardless of whether liability without fault is imposed or sought to be imposed on, the Indemnified Parties, except to the extent that such Indemnity is void or otherwise unenforceable under applicable law in effect on or validly retroactive to the date of this Lease and further except only to the extent such Claims are caused by or result from the willful misconduct or negligence of an Indemnified Party. The foregoing Indemnity shall include, without limitation, reasonable fees of attorneys, consultants and experts and related costs and City's costs of investigating any Claim. Tenant specifically acknowledges and agrees that it has an immediate and independent obligation to defend the City from any claim which actually or potentially falls within this indemnity provision even if such allegation is or may be groundless, fraudulent or false, which obligation arises at the time such claim is tendered to Tenant by City and continues at all times thereafter. Tenant's obligations under this Section shall survive the termination of this Lease.

19. INSURANCE

19.1 Tenant's Insurance

(a) Tenant, at no cost to the City, shall procure and keep in effect at all times during the Term insurance as follows:

(i) Commercial general liability insurance with limits not less than Two Million Dollars (\$2,000,000) each occurrence combined single limit for bodily injury and property damage, including contractual liability, independent contractors, broad-form property damage, fire damage legal liability (of not less than Fifty Thousand Dollars (\$50,000)), personal injury, products and completed operations, and explosion, collapse and underground (XCU).

(ii) Worker's Compensation Insurance with Employer's Liability Limits not less than One Million Dollars (\$1,000,000) each accident.

(iii) Business automobile liability insurance with limits not less than One Million Dollars (\$1,000,000) each occurrence combined single limit for bodily injury and property damage, including owned and non-owned and hired vehicles, as applicable, if Tenant uses automobiles in connection with its use of the Premises.

(iv) Licensed professionals (i.e., architects, engineers, certified public accountants, etc.) shall provide professional liability insurance to Tenant with limits not less than \$1,000,000 each claim with respect to negligent acts, errors or omissions in connection with professional services to be provided under this Lease or to the Premises.

(v) Such other insurance as is generally required by commercial owners of buildings similar in size, character, age and location as the Building, as may change from time to time.

(b) At all times during any period of Tenant's construction of Tenant Improvements or any Alterations (to the extent City is requiring the following insurance during the construction of such Alteration), Tenant shall, at no cost to the City, comply with the following additional insurance requirements:

(i) Tenant shall require Tenant's contractor to maintain (a) commercial general liability insurance with limits of not less than Three Million Dollars (\$3,000,000) combined single limit for bodily injury and property damage (including personal injury and death), and contractor's protective liability; and products and completed operations coverage in an amount not less than Five Hundred Thousand Dollars (\$500,000) per incident, One Million Dollars (\$1,000,000) in the aggregate; (b) comprehensive automobile liability insurance with a policy limit of not less than One Million Dollars (\$1,000,000) each accident for bodily injury and property damage, providing coverage at least as broad as the Insurance Services Office (ISO) Business Auto Coverage form covering Automobile Liability, "any auto", and insuring against all loss in connection with the ownership, maintenance and operation of automotive equipment that is owned, hired or non-owned; (c) worker's compensation with statutory limits and employer's liability insurance with limits of not less than One Hundred Thousand Dollars (\$100,000) per accident, Five Hundred Thousand Dollars (\$500,000) aggregate disease coverage and One Hundred Thousand Dollars (\$100,000) disease coverage per employee; and (d) contractor's pollution liability insurance with limits not less than \$1,000,000 each occurrence combined single limit.

(ii) Tenant shall cause Tenant's Agents (other than Tenant's contractor) to carry such insurance as shall be reasonably approved by City taking into account the nature and scope of the work and industry custom and practice.

(iii) Tenant shall carry "Builder's All Risk" insurance on a form reasonably approved by City, in the amount of one hundred percent (100%) of the completed value of all new construction, insuring all new construction, including all materials and equipment incorporated in, on or about the Premises, and in transit or storage off-site, that are or will be part of the permanent Improvements, against "all risk" and "special form" hazards, water damage (including groundwater damage and water damage resulting from backed up sewers and drains), and flood insurance.

(iv) Tenant shall require all providers of professional services, including architectural, design, engineering, geotechnical, and environmental professionals under contract with Tenant for any Tenant Improvements or any Alterations to maintain professional liability (errors or omissions) insurance, with limits not less than One Million Dollars (\$1,000,000.00) each claim and aggregate, with respect to all professional services provided to Tenant therefor.

(v) Should any of the insurance required to be maintained by Tenant (i.e., not by professionals retained by Tenant) be provided under a claims-made form, Tenant shall maintain such coverage continuously throughout the Term and, without lapse, for a period of three (3) years beyond the expiration or termination of this Lease, to the effect that, should occurrences during the Term give rise to claims made after expiration or termination of this Lease, such claims shall be covered by such claims-made policies.

(c) Should any of the required insurance be provided under a form of coverage that includes a general annual aggregate limit or provides that claims investigation or legal defense costs be included in such general annual aggregate limit, such general aggregate limit shall double the occurrence or claims limits specified above.

(d) All liability insurance policies shall be endorsed to provide the following:

(i) Name as additional insured the City and County of San Francisco, its officers, agents and employees.

(ii) That such policies are primary insurance to any other insurance available to the additional insureds, with respect to any claims arising out of this Lease, and that insurance applies separately to each insured against whom claim is made or suit is brought.

(e) Each insurance policy required pursuant to Section 19.1(a) above shall be issued by an insurance company licensed in the State of California and with a general policyholders' rating of "A-" or better and a financial size ranking of "Class VIII" or higher in the most recent edition of Best's Insurance Guide.

(f) Tenant shall provide thirty (30) days' prior written notice of cancellation, intended non-renewal, or reduction in coverage for any reason of any insurance policies Tenant is required to maintain hereunder. Notice to City shall be mailed to the address(es) for City set forth in the Basic Lease Information.

(g) Tenant shall deliver to City certificates of insurance and additional insured policy endorsements from insurers for the policies required in Section 19.1(a) in a form satisfactory to City, evidencing the coverage required hereunder, on or before the Effective Date, together with complete copies of the policies promptly upon City's request, and Tenant shall provide City with certificates or policies thereafter at least thirty (30) days before the expiration dates of expiring policies. Tenant shall deliver to City certificates of insurance and additional insured policy endorsements from insurers for the policies required in Section 19.1(b) in a form satisfactory to City, evidencing the coverage required hereunder, on or before the commencement of construction for the applicable Tenant Improvements or Alterations, together with complete copies of the policies promptly upon City's request, and Tenant shall provide City with certificates or policies thereafter at least thirty (30) days before the expiration dates of expiring policies. If Tenant fails to timely procure such insurance, or to timely deliver such policies or certificates, City may procure, at its option, without waiving any rights or remedies which City may have for Tenant's default hereunder, the same for the account of Tenant, and the cost thereof shall be paid to City within five (5) days after delivery to Tenant of bills therefor.

(h) Upon City's request, Tenant and City shall periodically review the limits and types of insurance carried pursuant to this Section. If the general commercial practice in the City and County of San Francisco is to carry liability insurance in an amount or coverage materially greater than the amount or coverage then being carried by Tenant for risks comparable to those associated with the Premises, then Tenant shall, at City's request, increase the amounts or coverage carried by Tenant to conform to such general commercial practice.

(i) Tenant's compliance with the provisions of this Section shall in no way relieve or decrease Tenant's liability under Section 18.2 (Tenant's Indemnity), or any of Tenant's other obligations under this Lease.

(j) Notwithstanding anything to the contrary in this Lease, if any of the required insurance coverage lapses, this Lease shall terminate upon three (3) days' notice to Tenant, unless Tenant renews the insurance coverage within notice period.

19.2 Tenant's Personal Property

Tenant shall be responsible, at no cost to the City, for separately insuring Tenant's Personal Property.

19.3 City's Self Insurance

Tenant acknowledges that City self-insures against casualty, property damage and public liability risks and agrees that City may at its sole election, but shall not be required to, carry any third party insurance with respect to the Building, the Premises or otherwise.

19.4 Waiver of Subrogation

Notwithstanding anything to the contrary in this Lease, City and Tenant (each a "Waiving Party") each hereby waives any right of recovery against the other party for any loss or damage relating to the Building or the Premises or any operations or contents therein, whether or not such loss is caused by the fault or negligence of such other party, to the extent such loss or damage is covered by third party insurance that is required to be purchased by the Waiving Party under this Lease or is actually covered by insurance held by the Waiving Party or its agents, or, in the case of City, since it does not carry insurance, to the extent such loss or damage would have been covered by the insurance customarily maintained by institutional property owners. Each Waiving Party agrees to obtain a waiver of subrogation rights endorsements from applicable insurance carriers issuing policies relating to the Building or the Premises; provided, the failure to obtain any such endorsement shall not affect the above waiver.

20. ACCESS BY CITY

City reserves for itself and any of its designated Agents, the right to enter the Premises as follows: (a) on a regular basis without advance notice to supply any necessary or agreed-upon service to be provided by City hereunder; (b) on an occasional basis, at all reasonable times after giving Tenant reasonable advance written or oral notice, to show the Premises to prospective tenants or other interested parties, to post notices of non-responsibility, to conduct any environmental audit of Tenant's use of the Premises, to repair, alter or improve any part of the Building, Building Systems or the Premises, and for any other lawful purpose; and (c) on an emergency basis without notice whenever City believes that emergency access is required. City shall have the right to use any means that it deems proper to open doors in an emergency in order to obtain access to any part of the Premises, and any such entry shall not be construed or deemed to be a forcible or unlawful entry into or a detainer of, the Premises, or an eviction, actual or constructive, of Tenant from the Premises or any portion thereof. Tenant shall not alter any lock or install any new or additional locking devices without the prior written consent of City. All locks installed in the Premises (excluding Tenant's vaults, safes or special security areas, if any, designated by Tenant in writing to City) shall be keyed to the Building master key system, and City shall at all times have a key with which to unlock all such doors.

21. CERTIFICATES

21.1 Tenant's Estoppel Certificates

Tenant, at any time and from time to time upon not less than ten (10) days' prior notice from City, shall execute and deliver to City or to any party designated by City a certificate stating: (a) that Tenant has accepted the Premises, (b) the Commencement Date and Expiration Date of this Lease, (c) that this Lease is unmodified and in full force and effect (or, if there have been modifications, that the Lease is in full force and effect as modified and stating the modifications), (d) whether or not there are then existing any defenses against the enforcement of any of Tenant's obligations hereunder (and if so, specifying the same), (e) whether or not there are any defaults then existing under this Lease (and if so specifying the same), (f) the dates, if any, to which the Base Rent, Percentage Rent, and Additional Charges have been paid, and (g) any other information that may be required.

21.2 City's Certificates

City, at any time and from time to time upon not less than ten (10) days' prior notice from Tenant, shall execute and deliver to Tenant or to any party designated by Tenant a certificate stating: (a) the Commencement Date and Expiration Date of this Lease, (b) that this Lease is unmodified and in full force and effect (or, if there have been modifications, that the Lease is in full force and effect as modified and stating the modifications), (c) whether or not there are any defaults then existing under this Lease (and if so specifying the same), (d) the dates, if any, to which the Base Rent, Percentage Rent, and Additional Charges have been paid, and (e) any other information that may be required.

22. RULES AND REGULATIONS

Tenant shall faithfully comply with the rules and regulations attached to this Lease as Exhibit H (Building Rules and Regulations) and all modifications thereof and additions thereto that City may from time to time put into effect (the "Rules and Regulations"). City shall not be responsible for the non-performance of the Rules and Regulations by any other tenant or occupant of the Building. In the event of any conflict between any provision of this Lease and any provision of the Rules and Regulations, this Lease shall control.

23. [Intentionally deleted]

24. SURRENDER OF PREMISES

City anticipates demolishing the Building following the Expiration Date. Upon the Expiration Date or other termination of this Lease, Tenant shall peaceably quit and surrender to City the Premises in broom clean condition, together with the Tenant Improvements and all Alterations approved by City, except for any portion of the Premises condemned and any damage and destruction for which Tenant is not responsible hereunder. If this Lease terminates prior to the Rent Commencement Date, Tenant shall cause the Leasehold Improvement Work completed as of such termination date to be in a safe condition. The Premises shall be surrendered free and clear of all liens and encumbrances other than liens and encumbrances existing as of the date of this Lease and any other encumbrances created by City. Except as otherwise set forth in Section 25, immediately before the Expiration Date or other termination of this Lease, Tenant shall remove all of Tenant's Personal Property as provided in this Lease, using commercially reasonable efforts to avoid any damage to any portion of the Premises. If such removal is not completed at the expiration or other termination of this Lease, City may remove the same at Tenant's expense. Tenant's obligations under this Section shall survive the Expiration Date or other termination of this Lease. Any items of Tenant's Personal Property remaining in the Premises after the Expiration Date or sooner termination of this Lease may, at

City's option, be deemed abandoned and disposed of in accordance with Section 1980 et seq. of the California Civil Code or in any other manner allowed by law.

Concurrently with the surrender of the Premises, Tenant shall, if requested by City, execute, acknowledge and deliver to City a quitclaim deed to the Premises and any other instrument reasonably requested by City to evidence or otherwise effect the termination of Tenant's leasehold estate hereunder and to effect such transfer or vesting of title to the Tenant Improvements or other improvements or equipment which remain part of the Premises. The terms of this Section shall survive the expiration or sooner termination of this Lease.

25. REMOVAL OF ELECTRICAL AND TELECOMMUNICATIONS WIRES

25.1 City May Elect to Remove or Retain Wires

Within thirty (30) days after the expiration or sooner termination of this Lease or at any time that the Wires (as defined below) are no longer in active use by Tenant, City may elect by written notice to Tenant to: (a) retain any or all wires, cables and similar installations appurtenant thereto (the "Wires") installed by or on behalf of Tenant within the Premises or any portion of the Building outside the Premises, including, without limitation, the plenums or risers of the Building; or (b) remove any or all of the Wires.

25.2 Compliance with Laws and Discontinuance of Wire Use

Tenant shall comply with all applicable laws with respect to the Wires, subject to City's right to elect to retain the Wires. Within thirty (30) days after Tenant discontinues the use of all or any part of the Wires, Tenant shall deliver to City written notice of such discontinuance, together with a plan or other reasonable description of the current type, quantity, points of commencement and termination, and routes of the Wires to allow City to determine if City desires to retain the Wires.

25.3 Condition of Wires

Tenant covenants that as of the expiration or sooner termination of this Lease, Tenant will be the sole owners of the Wires, Tenant will have the sole right to surrender the Wires, and the Wires shall be free of all liens and encumbrances.

25.4 Survival

The terms of this Section shall survive the expiration or sooner termination of this Lease.

26. HAZARDOUS MATERIALS

26.1 Definitions

As used herein, the following terms shall have the meanings set forth below:

(a) "Environmental Laws" shall mean any present or future federal, state, local or administrative law, rule, regulation, order or requirement relating to Hazardous Material (including, without limitation, its use, handling, transportation, production, disposal, discharge or storage), or to health and safety, industrial hygiene or the environment, including, without limitation, soil, air and groundwater conditions.

(b) "Hazardous Material" shall mean any material that, because of its quantity, concentration or physical or chemical characteristics, is at any time now or hereafter deemed by any federal, state or local governmental authority to pose a present or potential hazard to human health, welfare or safety or to the environment. Hazardous Material includes, without limitation,

any material or substance defined as a "hazardous substance," or "pollutant" or "contaminant" pursuant to the Comprehensive Environmental Response, Compensation and Liability Act of 1980 ("CERCLA", also commonly known as the "Superfund" law), as amended, (42 U.S.C. Section 9601 et seq.) or pursuant to Section 25316 of the California Health & Safety Code; any "hazardous waste" listed pursuant to Section 25140 of the California Health & Safety Code; and petroleum, including crude oil or any fraction thereof, natural gas or natural gas liquids.

(c) "Investigate and Remediate" ("Investigation" and "Remediation") shall mean the undertaking of any activities to determine the nature and extent of Hazardous Material that may be located in, on, under or about the Premises or that has been, are being or threaten to be Released into the environment, and to clean up, remove, contain, treat, stabilize, monitor or otherwise control such Hazardous Material.

(d) "Release" when used with respect to Hazardous Material shall include any actual or imminent spilling, leaking, pumping, pouring, emitting, emptying, discharging, injecting, escaping, leaching, dumping, or disposing into or inside the Building, or in, on, under or about any other part of the Premises or into the environment.

26.2 No Hazardous Materials

Tenant acknowledges there is asbestos in the black mastic used to affix the mirrors to the walls in the restrooms and may be other Hazardous Material at the Premises. Tenant covenants and agrees that neither Tenant nor any of its Agents or Invitees shall cause or permit any Hazardous Material to be brought upon, kept, used, stored, generated or disposed of in, on or about the Premises, or transported to or from the Premises, with the sole exception that Tenant may keep and use such substances in the Building in such reasonably limited amounts as are customarily used for general office, cleaning, janitorial and cooking purposes and may generate such substances as a result of measures taken pursuant to Articles 7 or 8 of this Lease that disturb or remove lead-based or presumed lead-based paint from the exterior or interior surfaces of the Premises so long as such generation, storage, transportation, use, and disposal are in compliance with all applicable Environmental Laws at all times. Tenant shall give immediate written notice to City of: (a) any action, proceeding or inquiry by any governmental authority (including, without limitation, the California State Department of Health Services, the State or any Regional Water Quality Control Board, the Bay Area Air Quality Management district or any local governmental entity) against Tenant with respect to the presence or Release or suspected presence or Release of Hazardous Material on the Premises or the migration thereof from or to other property; (b) all demands or claims made or threatened by any third party against Tenant or the Premises relating to any loss or injury resulting from any Hazardous Materials; (c) any Release of Hazardous Material on or about the Premises has occurred that may require any Investigation or Remediation; and (d) all matters of which Tenant is required to give notice pursuant to Section 25359.7 of the California Health and Safety Code.

26.3 Tenant's Environmental Indemnity

If Tenant breaches any of its obligations contained in this Section, or, if any act or omission of Tenant, its Agents or Invitees, results in any Release of Hazardous Material in, on, under or about the Premises in violation of any applicable Environmental Laws, including but not limited to Chapter 36 of the San Francisco Building Code, then, without limiting Tenant's Indemnity contained in Section 18.2 (Tenant's Indemnity), Tenant shall, on behalf of itself and its successors and assigns, Indemnify the Indemnified Parties, and each of them, from and against all Claims (including, without limitation, sums paid in settlement of claims, attorneys' fees, consultants' fees and experts' fees and costs) arising during or after the Term of this Lease and relating to such Release. The foregoing Indemnity includes, without limitation, costs incurred in connection with activities undertaken to Investigate and Remediate Hazardous Material and to restore the Premises to its prior condition, fines and penalties assessed for the violation of any applicable Environmental Laws including but not limited to Chapter 36 of the

San Francisco Building Code, and any natural resource damages. Without limiting the foregoing, if Tenant or any of its Agents or Invitees, causes or permits the Release of any Hazardous Materials in, on, under or about the Premises, Tenant shall immediately and at no expense to City take any and all appropriate actions to return the Premises affected thereby to the condition existing prior to such Release and otherwise Investigate and Remediate the Release in accordance with all Environmental Laws. Tenant specifically acknowledges and agrees that it has an immediate and independent obligation to defend the City from any claim which actually or potentially falls within this indemnity provision even if such allegation is or may be groundless, fraudulent or false, which obligation arises at the time such claim is tendered to Tenant by the City and continues at all times thereafter. Tenant shall afford City a full opportunity to participate in any discussions with governmental regulatory agencies regarding any settlement agreement, cleanup or abatement agreement, consent decree, or other compromise or proceeding involving Hazardous Material.

26.4 Survival of Obligation

Tenant's obligations under this Section 26 shall survive the Expiration Date or other termination of this Lease.

27. GENERAL PROVISIONS

27.1 Notices

Any notice given under this Lease shall be effective only if in writing and given by delivering the notice in person or by sending it first-class mail or certified mail with a return receipt requested or by overnight courier, return receipt requested, with postage prepaid, to: (a) Tenant, (i) at Tenant's address set forth in the Basic Lease Information, if sent prior to Tenant's taking possession of the Premises, or (ii) at the Premises if sent on or subsequent to Tenant's taking possession of the Premises, or (iii) at any place where Tenant or any Agent of Tenant may be found if sent subsequent to Tenant's vacating, abandoning or surrendering the Premises; or (b) City, at City's address set forth in the Basic Lease Information; or (c) to such other address as either City or Tenant may designate as its new address for such purpose by notice given to the other in accordance with the provisions of this Section at least ten (10) days prior to the effective date of such change. Any notice hereunder shall be deemed to have been given two (2) days after the date when it is mailed if sent by first class or certified mail, one day after the date it is made if sent by overnight courier, or upon the date personal delivery is made. For convenience of the parties, copies of notices may also be given by telefacsimile to the telephone number set forth in the Basic Lease Information or such other number as may be provided from time to time; however, neither party may give official or binding notice by facsimile. Tenant shall promptly provide City with copies of any and all notices received regarding any alleged violation of laws or insurance requirements or any alleged unsafe condition or practice.

27.2 No Implied Waiver

No failure by City to insist upon the strict performance of any obligation of Tenant under this Lease or to exercise any right, power or remedy arising out of a breach thereof, irrespective of the length of time for which such failure continues, no acceptance of full or partial Base Rent, Percentage Rent, or Additional Charges during the continuance of any such breach, and no acceptance of the keys to or possession of the Premises prior to the expiration of the Term by any Agent of City, shall constitute a waiver of such breach or of City's right to demand strict compliance with such term, covenant or condition or operate as a surrender of this Lease. No express written waiver of any default or the performance of any provision hereof shall affect any other default or performance, or cover any other period of time, other than the default, performance or period of time specified in such express waiver. One or more written waivers of a default or the performance of any provision hereof shall not be deemed to be a waiver of a

subsequent default or performance. Any consent by City hereunder shall not relieve Tenant of any obligation to secure the consent of City in any other or future instance under the terms of this Lease.

27.3 Amendments

Neither this Lease nor any terms or provisions hereof may be changed, waived, discharged or terminated, except by a written instrument signed by the party against which the enforcement of the change, waiver, discharge or termination is sought. No waiver of any breach shall affect or alter this Lease, but each and every term, covenant and condition of this Lease shall continue in full force and effect with respect to any other then-existing or subsequent breach thereof. Whenever this Lease requires or permits the giving by City of its consent or approval, the Director of Property, or his or her designee shall be authorized to provide such approval, except as otherwise provided by applicable law, including the Charter. Any amendments or modifications to this Lease, including, without limitation, amendments to or modifications to the exhibits to this Lease, shall be subject to the mutual written agreement of City and Tenant, and City's agreement may be made upon the sole approval of the Director of Property, or his or her designee; provided, however, material amendments or modifications to this Lease (a) changing the legal description of the Premises, (b) increasing the Term, (c) increasing the Rent, (d) changing the general use of the Premises from the use authorized under Section 5.1 (Permitted Use) of this Lease, and (e) any other amendment or modification which materially increases the City's liabilities or financial obligations under this Lease shall additionally require the approval of the City's Board of Supervisors.

27.4 Authority

If Tenant signs as a corporation or a partnership, each of the persons executing this Lease on behalf of Tenant does hereby covenant and warrant that Tenant is a duly authorized and existing entity, that Tenant has and is qualified to do business in California, that Tenant has full right and authority to enter into this Lease, and that each and all of the persons signing on behalf of Tenant are authorized to do so. Upon City's request, Tenant shall provide City with evidence reasonably satisfactory to City confirming the foregoing representations and warranties.

27.5 Parties and Their Agents; Approvals

The words "City" and "Tenant" as used herein shall include the plural as well as the singular. If there is more than one Tenant, the obligations and liabilities under this Lease imposed on Tenant shall be joint and several. As used herein, the term "Agents" when used with respect to either party shall include the agents, employees, officers, contractors and representatives of such party, and the term "Invitees" when used with respect to Tenant shall include the clients, customers, invitees, guests, licensees, assignees or subtenants of Tenant. All approvals, consents or other determinations permitted or required by City hereunder shall be made by or through City's Director of Property unless otherwise provided in this Lease, subject to applicable law.

27.6 Interpretation of Lease

The captions preceding the articles and sections of this Lease and in the table of contents have been inserted for convenience of reference only and such captions shall in no way define or limit the scope or intent of any provision of this Lease. This Lease has been negotiated at arm's length and between persons sophisticated and knowledgeable in the matters dealt with herein and shall be interpreted to achieve the intents and purposes of the parties, without any presumption against the party responsible for drafting any part of this Lease. Provisions in this Lease relating to number of days shall be calendar days, unless otherwise specified, provided that if the last day of any period to give notice, reply to a notice or to undertake any other action occurs on a Saturday, Sunday or a bank or City holiday, then the last day for undertaking the action or giving

or replying to the notice shall be the next succeeding business day. Use of the word "including" or similar words shall not be construed to limit any general term, statement or other matter in this Lease, whether or not language of non-limitation, such as "without limitation" or similar words, are used.

27.7 Successors and Assigns

Subject to the provisions of this Lease relating to Assignments and Subleases, the terms, covenants and conditions contained in this Lease shall bind and inure to the benefit of City and Tenant and, except as otherwise provided herein, their personal representatives and successors and assigns; provided, however, that upon any sale, assignment or transfer by City named herein (or by any subsequent landlord) of its interest in the Building as owner or lessee, including any transfer by operation of law, City (or any subsequent landlord) shall be relieved from all subsequent obligations and liabilities arising under this Lease subsequent to such sale, assignment or transfer.

27.8 Brokers

Neither party has had any contact or dealings regarding the leasing of the Premises, or any communication in connection therewith, through any licensed real estate broker or other person who could claim a right to a commission or finder's fee in connection with the lease contemplated herein except as identified in the Basic Lease Information, whose commission, if any is due, shall be paid pursuant to a separate written agreement between such broker and the party through which such broker contracted. In the event that any broker or finder perfects a claim for a commission or finder's fee based upon any such contact, dealings or communication, the party through whom the broker or finder makes a claim shall be responsible for such commission or fee and shall Indemnify the other party from any and all Claims incurred by the indemnified party in defending against the same. The provisions of this Section shall survive any termination of this Lease.

27.9 Severability

If any provision of this Lease or the application thereof to any person, entity or circumstance shall be invalid or unenforceable, the remainder of this Lease, or the application of such provision to persons, entities or circumstances other than those as to which it is invalid or unenforceable, shall not be affected thereby, and each other provision of this Lease shall be valid and be enforceable to the fullest extent permitted by law, except to the extent that enforcement of this Lease without the invalidated provision would be unreasonable or inequitable under all the circumstances or would frustrate a fundamental purpose of this Lease.

27.10 Governing Law

This Lease shall be construed and enforced in accordance with the laws of the State of California and the City's Charter.

27.11 Entire Agreement

This instrument, including the exhibits hereto, which are made a part of this Lease, contains the entire agreement between the parties and all prior written or oral negotiations, understandings and agreements are merged herein. The parties further intend that this Lease shall constitute the complete and exclusive statement of its terms and that no extrinsic evidence whatsoever (including prior drafts hereof and changes therefrom) may be introduced in any judicial, administrative or other legal proceeding involving this Lease. Tenant hereby acknowledges that neither City nor City's Agents have made any representations or warranties with respect to the Premises, the Building or this Lease except as expressly set forth herein, and

no rights, easements or licenses are or shall be acquired by Tenant by implication or otherwise unless expressly set forth herein.

27.12 Attorneys' Fees

In the event that either City or Tenant fails to perform any of its obligations under this Lease or in the event a dispute arises concerning the meaning or interpretation of any provision of this Lease, the defaulting party or the non-prevailing party in such dispute, as the case may be, shall pay the prevailing party reasonable attorneys' and experts' fees and costs, and all court costs and other costs of action incurred by the prevailing party in connection with the prosecution or defense of such action and enforcing or establishing its rights hereunder (whether or not such action is prosecuted to a judgment). For purposes of this Lease, the terms "court costs and reasonable attorneys' fees" shall mean the fees and expenses of counsel to the Parties, which may include printing, duplicating and other expenses, air freight charges, hiring of experts, and fees billed for law clerks, paralegals, librarians and others not admitted to the bar but performing services under the supervision of an attorney. The term "court costs and attorneys' fees" shall also include, without limitation, all such fees and expenses incurred with respect to appeals, mediation, arbitrations, and bankruptcy proceedings, and whether or not any action is brought with respect to the matter for which such fees and costs were incurred. For the purposes of this Lease, reasonable fees of attorneys of City's Office of the City Attorney shall be based on the fees regularly charged by private attorneys with the equivalent number of years of experience in the subject matter area of the law for which the City Attorney's services were rendered who practice in the City of San Francisco in law firms with approximately the same number of attorneys as employed by the Office of the City Attorney.

27.13 Holding Over

Tenant acknowledges that if it holds over at the Premises following the expiration or earlier termination of this Lease without City's consent could result in substantial City costs and expenses with respect to the development or other use of the Premises. Without limiting City's other rights and remedies set forth in this Lease, at law, or in equity, if Tenant retains possession of any portion of the Premises after the expiration or the earlier termination of this Lease, then unless City expressly agrees to the holdover in writing, Tenant shall pay City, on a month-to-month basis the Base Rent payable by Tenant hereunder prior to such expiration or termination, together with monthly payments equal to forty percent (40%) of Net Income (the "Holdover Payment") and an amount estimated by City for the monthly Additional Charges payable under this Lease, and shall otherwise be on the terms and conditions herein specified so far as applicable (except for those pertaining to the Term). Any failure by Tenant to surrender, discontinue using, or, if required by City, any failure to remove any property or equipment following written demand for the same by City, shall constitute continuing possession for purposes hereof. Tenant acknowledges that the foregoing provisions shall not serve as permission for the Tenant to hold over, nor serve to extend the term of this Lease beyond the end on the term hereof. Any holding over without City's consent shall constitute a default by Tenant and entitle City to exercise any or all of its remedies as provided herein, notwithstanding that City may elect to accept one or more payments of Rent, and whether or not such amounts are at the holdover rate specified above or the rate in effect at the end of the Term of this Lease. Any holding over after the expiration of the Term with the express consent of City shall be construed to automatically extend the Term of this Lease on a month-to-month basis at a Base Rent equal to the latest Base Rent payable by Tenant hereunder prior to such expiration, together with Percentage Rent and the amount estimated by City for the monthly Additional Charges payable under this Lease, and shall otherwise be on the terms and conditions herein specified so far as applicable (except for those pertaining to the Term).

During any period of holding over, Tenant shall provide monthly statements (each, a "Monthly Statement") for the immediately preceding month in a form approved by City and setting forth in reasonable detail the Gross Revenues for the immediately preceding month,

including an itemized list of any and all deductions or exclusions from Gross Revenues that Tenant may claim and which are expressly permitted under this Lease, the Expenses for the immediately preceding month, and a computation of the Percentage Rent or the Holdover Payment, as applicable, for the immediately preceding month. Each Monthly Statement shall be certified as accurate, complete and current by Tenant's president and chief financial officer. Within the sixty (60) day period immediately following Tenant's vacation of the Premises after any period of holding over, Tenant shall provide a final statement (the "Final Statement"), certified as accurate, complete and current by an independent certified public accounting firm acceptable to City's Director of Property in his or her sole discretion and in a form approved by City, setting forth in reasonable detail the Gross Revenues for such period, including an itemized list of any and all deductions or exclusions from Gross Revenues that Tenant may claim and which are expressly permitted under this Lease, the Expenses for such period, and a computation of the Percentage Rent or Holdover Payments, as applicable, for such period. If the Final Statement shows Tenant underpaid the Percentage Rent or Holdover Payments, as applicable, for the holdover period, Tenant shall deliver the remaining amount owed to City within thirty (30) days of receiving City's invoice therefor, together with interest from the date of the error in the payment equal to ten percent (10%) per year or, if a higher rate is legally permissible, the highest rate an individual is permitted to charge under applicable law, if City elects, in its sole discretion, to charge such interest. If an audit reveals that Tenant has overpaid Percentage Rent or Holdover Payments, as applicable, for the holdover period, within sixty (60) days of receiving the Final Statement, City shall reimburse Tenant in an amount equal to the amount Tenant has overpaid.

If Tenant fails to deliver any Monthly Statement or Final Statement within the time period set forth in this Section (irrespective of whether any Percentage Rent or Holdover Payment, as applicable, is actually paid or due to City for the applicable period) and such failure continues for three (3) days after the date Tenant receives (or refuses receipt of) written notice of such failure from City, City shall have the right, among its other remedies under this Lease, to employ a certified public accountant to make such examination of the Books and Records of Tenant and of any other occupant of the Premises as may be necessary to certify the amount of the Gross Revenues and Expenses for the period in question. Such certification shall be binding upon Tenant and Tenant shall promptly pay to City the total reasonable cost of the examination and City's other reasonable costs (including attorneys' fees) in exercising its examination rights hereunder, together with the full amount of Percentage Rent or Holdover Payment, as applicable, due and payable for the period in question. Tenant acknowledges that the late submittal of any Monthly Statement or Final Statement will cause City increased costs not contemplated by this Lease, the exact amount of which will be extremely difficult to ascertain. The parties agree that the charges set forth in this Section represent a fair and reasonable estimate of the cost that City will incur by reason of Tenant's lateness.

Tenant's obligations under this Section shall survive the expiration or termination of this Lease.

27.14 Time of Essence

Time is of the essence with respect to all provisions of this Lease in which a definite time for performance is specified.

27.15 Cumulative Remedies

All rights and remedies of either party hereto set forth in this Lease shall be cumulative, except as may otherwise be provided herein.

27.16 Survival of Indemnities

Termination of this Lease shall not affect the right of either party to enforce any and all indemnities and representations and warranties given or made to the other party under this Lease,

nor shall it affect any provision of this Lease that expressly states it shall survive termination hereof.

27.17 Signs

Tenant agrees that it will not erect or maintain, or permit to be erected or maintained, any signs, notices or graphics upon or about the Premises which are visible from the exterior of the Premises, without City's prior written consent, which City may withhold or grant in its sole discretion.

27.18 Relationship of the Parties

City is not, and none of the provisions in this Lease shall be deemed to render City, a partner in Tenant's business, or joint venturer or member in any joint enterprise with Tenant. Neither party shall act as the agent of the other party in any respect hereunder. This Lease is not intended nor shall it be construed to create any third party beneficiary rights in any third party, unless otherwise expressly provided.

27.19 Light and Air

Tenant covenants and agrees that no diminution of light, air or view by any structure that may hereafter be erected (whether or not by City) shall entitle Tenant to any reduction of the Base Rent, Percentage Rent, or Additional Charges under this Lease, result in any liability of City to Tenant, or in any other way affect this Lease or Tenant's obligations hereunder.

27.20 No Recording

Tenant shall not record this Lease or any memorandum hereof in the public records.

27.21 Public Transit Information

Tenant shall establish and carry on during the Term a program to encourage maximum use of public transportation by personnel of Tenant employed on the Premises, including, without limitation, the distribution to such employees of written materials explaining the convenience and availability of public transportation facilities adjacent or proximate to the Building and encouraging use of such facilities, all at Tenant's sole expense.

27.22 Taxes, Assessments, Licenses, Permit Fees and Liens

(a) Tenant recognizes and understands that this Lease may create a possessory interest subject to property taxation and that Tenant may be subject to the payment of property taxes levied on such interest.

(b) Tenant agrees to pay taxes of any kind, including possessory interest taxes, that may be lawfully assessed on the leasehold interest hereby created and to pay all other taxes, excises, licenses, permit charges and assessments based on Tenant's usage of the Premises that may be imposed upon Tenant by law, all of which shall be paid when the same become due and payable and before delinquency.

(c) Tenant agrees not to allow or suffer a lien for any such taxes to be imposed upon the Premises or upon any equipment or property located thereon without promptly discharging the same, provided that Tenant, if so desiring, may have reasonable opportunity to contest the validity of the same.

(d) San Francisco Administrative Code Sections 23.38 and 23.39 require that the City and County of San Francisco report certain information relating to this Lease, and any

renewals thereof, to the County Assessor within sixty (60) days after any such transaction, and that Tenant report certain information relating to any assignment of or sublease under this Lease to the County Assessor within sixty (60) days after such assignment or sublease transaction. Tenant agrees to provide such information as may be requested by the City to enable the City to comply with this requirement.

27.23 Non-Liability of City Officials, Employees and Agents

No elective or appointive board, commission, member, officer, employee or other Agent of City shall be personally liable to Tenant, its successors and assigns, in the event of any default or breach by City or for any amount which may become due to Tenant, its successors and assigns, or for any obligation of City under this Agreement.

27.24 Non-Discrimination in City Contracts and Benefits Ordinance

(a) Covenant Not to Discriminate

In the performance of this Lease, Tenant agrees not to discriminate against any employee, any City employee working with Tenant, or applicant for employment with Tenant, or against any person seeking accommodations, advantages, facilities, privileges, services, or membership in all business, social, or other establishments or organizations, on the basis of the fact or perception of a person's race, color, creed, religion, national origin, ancestry, age, height, weight, sex, sexual orientation, gender identity, domestic partner status, marital status, disability or Acquired Immune Deficiency Syndrome or HIV status (AIDS/HIV status), or association with members of such protected classes, or in retaliation for opposition to discrimination against such classes.

(b) Subleases and Other Subcontracts

Tenant shall include in all Subleases and other subcontracts relating to the Premises a non-discrimination clause applicable to such Subtenant or other subcontractor in substantially the form of subsection (a) above. In addition, Tenant shall incorporate by reference in all subleases and other subcontracts the provisions of Sections 12B.2(a), 12B.2(c)-(k), and 12C.3 of the San Francisco Administrative Code and shall require all subtenants and other subcontractors to comply with such provisions. Tenant's failure to comply with the obligations in this subsection shall constitute a material breach of this Lease.

(c) Non-Discrimination in Benefits

Tenant does not as of the date of this Lease and will not during the term of this Lease, in any of its operations in San Francisco, on real property owned by City, or where the work is being performed for the City elsewhere within the United States, discriminate in the provision of bereavement leave, family medical leave, health benefits, membership or membership discounts, moving expenses, pension and retirement benefits or travel benefits, as well as any benefits other than the benefits specified above, between employees with domestic partners and employees with spouses, and/or between the domestic partners and spouses of such employees, where the domestic partnership has been registered with a governmental entity pursuant to state or local law authorizing such registration, subject to the conditions set forth in Section 12B.2(b) of the San Francisco Administrative Code.

(d) CMD Form

As a condition to this Lease, Tenant shall execute the "Chapter 12B Declaration: Nondiscrimination in Contracts and Benefits" form (Form CMD-12B-101) with supporting documentation and secure the approval of the form by the San Francisco Contract Monitoring Division. Tenant hereby represents that prior to execution of this Lease, (i) Tenant executed and

submitted to the CMD Form CMD-12B-101 with supporting documentation, and (ii) the CMD approved such form.

(e) Incorporation of Administrative Code Provisions by Reference

The provisions of Chapters 12B and 12C of the San Francisco Administrative Code relating to non-discrimination by parties contracting for the lease of City property are incorporated in this Section by reference and made a part of this Agreement as though fully set forth herein. Tenant shall comply fully with and be bound by all of the provisions that apply to this Lease under such Chapters of the Administrative Code, including but not limited to the remedies provided in such Chapters. Without limiting the foregoing, Tenant understands that pursuant to Section 12B.2(h) of the San Francisco Administrative Code, a penalty of Fifty Dollars (\$50) for each person for each calendar day during which such person was discriminated against in violation of the provisions of this Lease may be assessed against Tenant and/or deducted from any payments due Tenant.

27.25 No Relocation Assistance; Waiver of Claims

Tenant acknowledges that it will not be a displaced person at the time this Lease is terminated or expires by its own terms, and Tenant fully RELEASES, WAIVES AND DISCHARGES forever any and all Claims against, and covenants not to sue, City, its departments, commissions, officers, directors and employees, and all persons acting by, through or under each of them, under any laws, including, without limitation, any and all claims for relocation benefits or assistance from City under federal and state relocation assistance laws (including, but not limited to, California Government Code Section 7260 et seq.), except as otherwise specifically provided in this Lease with respect to a Taking.

27.26 MacBride Principles - Northern Ireland

The provisions of San Francisco Administrative Code §12F are incorporated herein by this reference and made part of this Lease. By signing this Lease, Tenant confirms that Tenant has read and understood that the City urges companies doing business in Northern Ireland to resolve employment inequities and to abide by the MacBride Principles, and urges San Francisco companies to do business with corporations that abide by the MacBride Principles.

27.27 Tropical Hardwood and Virgin Redwood Ban

The City and County of San Francisco urges companies not to import, purchase, obtain or use for any purpose, any tropical hardwood, tropical hardwood wood product, virgin redwood or virgin redwood wood product. Except as expressly permitted by the application of Sections 802(b) and 803(b) of the San Francisco Environment Code, Tenant shall not provide any items to the construction of Tenant Improvements or the Alterations, or otherwise in the performance of this Lease which are tropical hardwoods, tropical hardwood wood products, virgin redwood, or virgin redwood wood products. In the event Tenant fails to comply in good faith with any of the provisions of Chapter 8 of the San Francisco Environment Code, Tenant shall be liable for liquidated damages for each violation in any amount equal to Tenant's net profit on the contract, or five percent (5%) of the total amount of the contract dollars, whichever is greater.

27.28 Restrictions on the Use of Pesticides

Chapter 3 of the San Francisco Environment Code (the Integrated Pest Management Program Ordinance or "IPM Ordinance") describes an integrated pest management ("IPM") policy to be implemented by all City departments. Tenant shall not use or apply or allow the use or application of any pesticides on the Premises or contract with any party to provide pest abatement or control services to the Premises without first receiving City's written approval of

an IPM plan that (i) lists, to the extent reasonably possible, the types and estimated quantities of pesticides that Tenant may need to apply to the Premises during the term of this Lease, (ii) describes the steps Tenant will take to meet the City's IPM Policy described in Section 300 of the IPM Ordinance, and (iii) identifies, by name, title, address and telephone number, an individual to act as the Tenant's primary IPM contact person with the City. Tenant shall comply, and shall require all of Tenant's contractors to comply, with the IPM plan approved by the City and shall comply with the requirements of Sections 300(d), 302, 304, 305(f), 305(g), and 306 of the IPM Ordinance, as if Tenant were a City department. Among other matters, such provisions of the IPM Ordinance: (a) provide for the use of pesticides only as a last resort, (b) prohibit the use or application of pesticides on property owned by the City, except for pesticides granted an exemption under Section 303 of the IPM Ordinance (including pesticides included on the most current Reduced Risk Pesticide List compiled by City's Department of the Environment), (c) impose certain notice requirements, and (d) require Tenant to keep certain records and to report to City all pesticide use at the Premises by Tenant's staff or contractors.

If Tenant or Tenant's contractor will apply pesticides to outdoor areas at the Premises, Tenant must first obtain a written recommendation from a person holding a valid Agricultural Pest Control Advisor license issued by the California Department of Pesticide Regulation ("CDPR") and any such pesticide application shall be made only by or under the supervision of a person holding a valid, CDPR-issued Qualified Applicator certificate or Qualified Applicator license. City's current Reduced Risk Pesticide List and additional details about pest management on City property can be found at the San Francisco Department of the Environment website, <http://sfenvironment.org/ipm>.

27.29 First Source Hiring Agreement

Tenant and City are parties to the First Source Agreement attached to this Lease as Exhibit G pursuant to San Francisco Administrative Code, Chapter 83 (the "First Source Agreement"). Any default by Tenant under the First Source Agreement shall be a default under this Lease.

27.30 Sunshine Ordinance

In accordance with Section 67.24(e) of the San Francisco Administrative Code, contracts, contractors' bids, leases, agreements, responses to Requests for Proposals, and all other records of communications between City and persons or firms seeking contracts will be open to inspection immediately after a contract has been awarded. Nothing in this provision requires the disclosure of a private person's or organization's net worth or other proprietary financial data submitted for qualification for a contract, lease, agreement or other benefit until and unless that person or organization is awarded the contract, lease, agreement or benefit. Information provided which is covered by this Section will be made available to the public upon request.

27.31 Conflicts of Interest

Through its execution of this Lease, Tenant acknowledges that it is familiar with the provisions of Article III, Chapter 2 of City's Campaign and Governmental Conduct Code, and Section 87100 et seq. and Section 1090 et seq. of the Government Code of the State of California, and certifies that it does not know of any facts which would constitute a violation of said provisions, and agrees that if Tenant becomes aware of any such fact during the term of this Lease Tenant shall immediately notify the City.

27.32 Charter Provisions

This Lease is governed by and subject to the provisions of the Charter of the City and County of San Francisco.

27.33 Drug-Free Workplace

Tenant acknowledges that pursuant to the Federal Drug-Free Workplace Act of 1989, the unlawful manufacture, distribution, possession or use of a controlled substance is prohibited on City premises. Tenant agrees that any violation of this prohibition by Tenant, its Agents or assigns shall be deemed a material breach of this Lease.

27.34 Prohibition of Tobacco Sales and Advertising

Tenant acknowledges and agrees that no advertising or sale of cigarettes or tobacco products is allowed on the Premises. This advertising prohibition includes the placement of the name of a company producing cigarettes or tobacco products or the name of any cigarette or tobacco product in any promotion of any event or product.

27.35 Counterparts

This Lease may be executed in two or more counterparts, each of which shall be deemed an original, but all of which taken together shall constitute one and the same instrument.

27.36 Effective Date

This Lease shall become effective on the date upon which (a) City's Board of Supervisors and the Mayor, in their sole and absolute discretion, adopt a resolution or enact an ordinance approving this Lease in accordance with all applicable laws and (b) this Lease is duly executed and delivered by the parties hereto.

27.37 Acceptance of Lease by Tenant

This Lease shall be null and void unless Tenant accepts it and returns to City three (3) fully executed counterparts hereof on or before 5:00 p.m. San Francisco Time on February 16, 2018.

27.38 Requiring Health Benefits for Covered Employees

Unless exempt, Tenant agrees to comply fully with and be bound by all of the provisions of the Health Care Accountability Ordinance (HCAO), as set forth in San Francisco Administrative Code Chapter 12Q, including the remedies provided, and implementing regulations, as the same may be amended from time to time. The provisions of Chapter 12Q are incorporated herein by reference and made a part of this Lease as though fully set forth. The text of the HCAO is available on the web at <http://www.sfgov.org/olse/hcao>. Capitalized terms used in this Section and not defined in this Lease shall have the meanings assigned to such terms in Chapter 12Q.

(a) For each Covered Employee, Tenant shall provide the appropriate health benefit set forth in Section 12Q.3 of the HCAO. If Tenant chooses to offer the health plan option, such health plan shall meet the minimum standards set forth by the San Francisco Health Commission.

(b) Notwithstanding the above, if the Tenant is a small business as defined in Section 12Q.3(d) of the HCAO, it shall have no obligation to comply with subsection (a) above.

(c) Tenant's failure to comply with the HCAO shall constitute a material breach of this Lease. City shall notify Tenant if such a breach has occurred. If, within thirty (30) days after receiving City's written notice of a breach of this Lease for violating the HCAO, Tenant fails to cure such breach or, if such breach cannot reasonably be cured within such period of thirty (30) days, Tenant fails to commence efforts to cure within such period, or thereafter

fails diligently to pursue such cure to completion, City shall have the right to pursue the remedies set forth in Section 12Q.5(f)(1-5). Each of these remedies shall be exercisable individually or in combination with any other rights or remedies available to City.

(d) Any Subcontract entered into by Tenant shall require the Subcontractor to comply with the requirements of the HCAO and shall contain contractual obligations substantially the same as those set forth in this Section. Tenant shall notify City's Purchasing Department when it enters into such a Subcontract and shall certify to the Purchasing Department that it has notified the Subcontractor of the obligations under the HCAO and has imposed the requirements of the HCAO on Subcontractor through the Subcontract. Each Tenant shall be responsible for its Subcontractors' compliance with this Chapter. If a Subcontractor fails to comply, the City may pursue the remedies set forth in this Section against Tenant based on the Subcontractor's failure to comply, provided that City has first provided Tenant with notice and an opportunity to obtain a cure of the violation.

(e) Tenant shall not discharge, reduce in compensation, or otherwise discriminate against any employee for notifying City with regard to Tenant's compliance or anticipated compliance with the requirements of the HCAO, for opposing any practice proscribed by the HCAO, for participating in proceedings related to the HCAO, or for seeking to assert or enforce any rights under the HCAO by any lawful means.

(f) Tenant represents and warrants that it is not an entity that was set up, or is being used, for the purpose of evading the intent of the HCAO.

(g) Tenant shall keep itself informed of the current requirements of the HCAO.

(h) Tenant shall provide reports to the City in accordance with any reporting standards promulgated by the City under the HCAO, including reports on Subcontractors and Subtenants, as applicable.

(i) Tenant shall provide City with access to records pertaining to compliance with HCAO after receiving a written request from City to do so and being provided at least five (5) business days to respond.

(j) City may conduct random audits of Tenant to ascertain its compliance with HCAO. Tenant agrees to cooperate with City when it conducts such audits.

(k) If Tenant is exempt from the HCAO when this Lease is executed because its amount is less than Fifty Thousand Dollars (\$50,000), but Tenant later enters into an agreement or agreements that cause Tenant's aggregate amount of all agreements with City to reach Seventy-Five Thousand Dollars (\$75,000), all the agreements shall be thereafter subject to the HCAO. This obligation arises on the effective date of the agreement that causes the cumulative amount of agreements between Tenant and the Contracting Department to be equal to or greater than Seventy-Five Thousand Dollars (\$75,000) in the fiscal year.

27.39 Notification of Limitations on Contributions

Through its execution of this Lease, Tenant acknowledges that it is familiar with Section 1.126 of the San Francisco Campaign and Governmental Conduct Code, which prohibits any person who contracts with the City for the selling or leasing of any land or building to or from the City whenever such transaction would require approval by a City elective officer, the board on which that City elective officer serves, or a board on which an appointee of that individual serves, from making any campaign contribution to (a) the City elective officer, (b) a candidate for the office held by such individual, or (c) a committee controlled by such individual or candidate, at any time from the commencement of negotiations for the contract

until the later of either the termination of negotiations for such contract or six months after the date the contract is approved. Tenant acknowledges that the foregoing restriction applies only if the contract or a combination or series of contracts approved by the same individual or board in a fiscal year have a total anticipated or actual value of \$50,000 or more. Tenant further acknowledges that the prohibition on contributions applies to each Tenant; each member of Tenant's board of directors, and Tenant's chief executive officer, chief financial officer and chief operating officer; any person with an ownership interest of more than twenty percent (20%) in Tenant; any subcontractor listed in the contract; and any committee that is sponsored or controlled by Tenant. Additionally, Tenant acknowledges that Tenant must inform each of the persons described in the preceding sentence of the prohibitions contained in Section 1.126. Tenant further agrees to provide to City the name of each person, entity or committee described above.

27.40 Preservative-Treated Wood Containing Arsenic

Tenant may not purchase preservative-treated wood products containing arsenic in the performance of this Lease unless an exemption from the requirements of Environment Code Chapter 13 is obtained from the Department of Environment under Section 1304 of the Environment Code. The term "preservative-treated wood containing arsenic" shall mean wood treated with a preservative that contains arsenic, elemental arsenic, or an arsenic copper combination, including, but not limited to, chromated copper arsenate preservative, ammoniac copper zinc arsenate preservative, or ammoniacal copper arsenate preservative. Tenant may purchase preservative-treated wood products on the list of environmentally preferable alternatives prepared and adopted by the Department of Environment. This provision does not preclude Tenant from purchasing preservative-treated wood containing arsenic for saltwater immersion. The term "saltwater immersion" shall mean a pressure-treated wood that is used for construction purposes or facilities that are partially or totally immersed in saltwater.

27.41 Resource-Efficient City Buildings

Tenant acknowledges that the City and County of San Francisco has enacted San Francisco Environment Code Sections 700 to 713 relating to green building requirements for the design, construction, and operation of buildings owned or leased by City. Tenant hereby agrees that it shall comply with all applicable provisions of such code sections.

26.42 Food Service and Packaging Waste Reduction Ordinance

All undefined, initially-capitalized terms used in this Section shall have the meanings given to them in Chapter 15 of the San Francisco Environment Code (the "Food Service and Packaging Waste Reduction Ordinance"), which among other things, prohibits the provision of Prepared Food in Food Service Ware made, in whole or part, from Polystyrene Foam or in Food Service Ware that is not Compostable or Recyclable. Tenant agrees to comply fully with and be bound by all of the provisions of the Food Service and Packaging Waste Reduction Ordinance, including the remedies provided therein, and implementing guidelines and rules. The provisions of Chapter 16 are incorporated herein by reference and made a part of this Lease as though fully set forth herein. This provision is a material term of this Lease. By entering into this Lease, Tenant agrees that if it breaches this provision, City will suffer actual damages that will be impractical or extremely difficult to determine. Without limiting City's other rights and remedies, Tenant agrees that the sum of One Hundred Dollars (\$100.00) liquidated damages for the first breach, Two Hundred Dollars (\$200.00) liquidated damages for the second breach in the same year, and Five Hundred Dollars (\$500.00) liquidated damages for subsequent breaches in the same year is a reasonable estimate of the damage that City will incur based on the violation, established in light of the circumstances existing at the time this Lease was made. Such amounts shall not be considered a penalty, but rather agreed monetary damages sustained by City because of Tenant's failure to comply with this provision.

26.43 San Francisco Packaged Water Ordinance

Tenant agrees to comply with San Francisco Environment Code Chapter 24 ("Chapter 24"). Tenant shall not sell, provide or otherwise distribute Packaged Water, as defined in Chapter 24 (including bottled water), in the performance of this Agreement or on City property unless Tenant obtains a waiver from the City's Department of the Environment. If Tenant violates this requirement, the City may exercise all remedies in this Agreement and the Director of the City's Department of the Environment may impose administrative fines as set forth in Chapter 24.

27.44 Criminal History in Hiring and Employment Decisions

(a) Unless exempt, Tenant agrees to comply with and be bound by all of the provisions of San Francisco Administrative Code Chapter 12T (Criminal History in Hiring and Employment Decisions; "Chapter 12 T"), which are hereby incorporated as may be amended from time to time, with respect to applicants and employees of Tenant who would be or are performing work at the Premises.

(b) Tenant shall incorporate by reference the provisions of Chapter 12T in all subleases of some or all of the Premises, and shall require all subtenants to comply with such provisions. Tenant's failure to comply with the obligations in this subsection shall constitute a material breach of this Lease.

(c) Tenant and subtenants shall not inquire about, require disclosure of, or if such information is received base an Adverse Action on an applicant's or potential applicant for employment, or employee's: (1) Arrest not leading to a Conviction, unless the Arrest is undergoing an active pending criminal investigation or trial that has not yet been resolved; (2) participation in or completion of a diversion or a deferral of judgment program; (3) a Conviction that has been judicially dismissed, expunged, voided, invalidated, or otherwise rendered inoperative; (4) a Conviction or any other adjudication in the juvenile justice system; (5) a Conviction that is more than seven years old, from the date of sentencing; or (6) information pertaining to an offense other than a felony or misdemeanor, such as an infraction.

(d) Tenant and subtenants shall not inquire about or require applicants, potential applicants for employment, or employees to disclose on any employment application the facts or details of any conviction history, unresolved arrest, or any matter identified in subsection (c) above. Tenant and subtenants shall not require such disclosure or make such inquiry until either after the first live interview with the person, or after a conditional offer of employment.

(e) Tenant and subtenants shall state in all solicitations or advertisements for employees that are reasonably likely to reach persons who are reasonably likely to seek employment with Tenant or subtenant at the Premises, that the Tenant or subtenant will consider for employment qualified applicants with criminal histories in a manner consistent with the requirements of Chapter 12T.

(f) Tenant and subtenants shall post the notice prepared by the Office of Labor Standards Enforcement ("OLSE"), available on OLSE's website, in a conspicuous place at the Premises and at other workplaces within San Francisco where interviews for job opportunities at the Premises occur. The notice shall be posted in English, Spanish, Chinese, and any language spoken by at least 5% of the employees at the Premises or other workplace at which it is posted.

(g) Tenant and subtenants understand and agree that upon any failure to comply with the requirements of Chapter 12T, the City shall have the right to pursue any rights or remedies available under Chapter 12T or this Lease, including but not limited to a penalty of

\$50 for a second violation and \$100 for a subsequent violation for each employee, applicant or other person as to whom a violation occurred or continued, termination or suspension in whole or in part of this Lease.

(h) If Tenant has any questions about the applicability of Chapter 12T, it may contact the City's Real Estate Division for additional information. City's Real Estate Division may consult with the Director of the City's Office of Contract Administration who may also grant a waiver, as set forth in Section 12T.8.

27.45 Cooperative Drafting

This Lease has been drafted through a cooperative effort of both parties, and both parties have had an opportunity to have the Lease reviewed and revised by legal counsel. No party shall be considered the drafter of this Lease, and no presumption or rule that an ambiguity shall be construed against the party drafting the clause shall apply to the interpretation or enforcement of this Lease.

27.46 Vending Machines; Nutritional Standards

Tenant shall not install or permit any vending machine on the Premises without the prior written consent of the Director of Property. Any permitted vending machine must comply with the food nutritional and calorie labeling requirements set forth in San Francisco Administrative Code section 4.9-1(c), as may be amended from time to time (the "Nutritional Standards Requirements"). Tenant agrees to incorporate the Nutritional Standards Requirements into any contract for the installation of a vending machine on the Premises or for the supply of food and beverages to that vending machine. Failure to comply with the Nutritional Standards Requirements or to otherwise comply with this Section shall be deemed a material breach of this Lease. Without limiting Landlord's other rights and remedies under this Lease, Landlord shall have the right to require the immediate removal of any vending machine on the Premises that is not permitted or that violates the Nutritional Standards Requirements. In addition, any restaurant located on the Premises is encouraged to ensure that at least 25% of Meals offered on the menu meet the nutritional standards set forth in San Francisco Administrative Code section 4.9-1(e), as may be amended.

27.47 All-Gender Toilet Facilities

If applicable, Tenant shall comply with San Francisco Administrative Code Section 4.1-3 requiring at least one all-gender toilet facility on each floor of any new building on City-owned land and within existing buildings leased by the City where extensive renovations are made. An "all-gender toilet facility" means a toilet that is not restricted to use by persons of a specific sex or gender identity by means of signage, design, or the installation of fixtures, and "extensive renovations" means any renovation where the construction cost exceeds 50% of the cost of providing the toilet facilities required by this section. If Tenant has any question about applicability or compliance, Tenant should contact City's Director of Property for guidance.

27.48 Employee Signature Authorization Ordinance

City has adopted an Employee Signature Authorization Ordinance (S.F. Admin Code Sections 23.50-23.56). That ordinance requires employers of employees in hotel or restaurant projects on public property with fifty (50) or more employees (whether full-time or part-time) to enter into a "card check" agreement with a labor union regarding the preference of employees to be represented by a labor union to act as their exclusive bargaining representative. Tenant shall comply with the requirements of such ordinance, if applicable, including, without limitation, any requirements in the ordinance with respect to its subtenants, licensees, and operators.

NOTWITHSTANDING ANYTHING TO THE CONTRARY CONTAINED IN THIS LEASE, TENANT ACKNOWLEDGES AND AGREES THAT NO OFFICER OR EMPLOYEE OF CITY HAS AUTHORITY TO COMMIT CITY TO THIS LEASE UNLESS AND UNTIL CITY'S BOARD OF SUPERVISORS SHALL HAVE DULY ADOPTED A RESOLUTION OR ENACTED AN ORDINANCE APPROVING THIS LEASE AND AUTHORIZING THE TRANSACTIONS CONTEMPLATED HEREBY. THEREFORE, ANY OBLIGATIONS OR LIABILITIES OF CITY HEREUNDER ARE CONTINGENT UPON ADOPTION OF SUCH A RESOLUTION OR ORDINANCE, AND THIS LEASE SHALL BE NULL AND VOID IF CITY'S MAYOR AND THE BOARD OF SUPERVISORS DO NOT APPROVE THIS LEASE, IN THEIR RESPECTIVE SOLE DISCRETION. APPROVAL OF THIS LEASE BY ANY DEPARTMENT, COMMISSION OR AGENCY OF CITY SHALL NOT BE DEEMED TO IMPLY THAT SUCH RESOLUTION OR ORDINANCE WILL BE ENACTED, NOR WILL ANY SUCH APPROVAL CREATE ANY BINDING OBLIGATIONS ON CITY.

[REMAINDER OF PAGE INTENTIONALLY BLANK]

City and Tenant have executed this Lease as of the date first written above.

TENANT:

LA COCINA, INC.,
a California non-profit organization

By: _____

Its: _____

Date: _____

By: _____

Its: _____

Date: _____

CITY:

CITY AND COUNTY OF SAN FRANCISCO,
a municipal corporation

By: _____

ANDRICO Q. PENICK
Director of Property

Date: _____

RECOMMENDED:

APPROVED AS TO FORM:

DENNIS J. HERRERA, City Attorney

By: _____
Carol Wong, Deputy City Attorney

EXHIBIT A

DEPICTION AND DESCRIPTION OF PREMISES

[TO BE INSERTED BY CITY PRIOR TO CITY'S LEASE EXECUTION]

EXHIBIT B

WORK LETTER

[TO BE INSERTED BY CITY AND TENANT PRIOR TO BOS APPROVAL]

EXHIBIT C

AMENDED EASEMENT AGREEMENTS

[TO BE INSERTED BY CITY PRIOR TO CITY'S LEASE EXECUTION]

EXHIBIT D

NOTICE OF RENT COMMENCEMENT DATE

[Date]

Mr. Andrico Q. Penick
Director of Property
Real Estate Division
City and County of San Francisco
25 Van Ness Avenue, Suite 400
San Francisco, California 94102

RE: Acknowledgement of Rent Commencement Date and Expiration Date, Lease Between _____ (Tenant), and the City and County of San Francisco (Landlord), for the Premises located at _____

Dear Mr. Penick:

This letter will confirm that for all purposes of the Lease, the Rent Commencement Date (as defined in Section 3.2 of the Lease) is _____, 20__ and the Expiration Date (as defined in Section 3.2 of the Lease) is _____, 20__.

Please acknowledge your acceptance of this letter by signing and returning a copy of this letter.

Very truly yours,

By: _____
Title: _____

Accepted and Agreed:

By: _____
Andrico Q. Penick
Director of Property

Dated: _____

EXHIBIT E

APPROVED TENANT'S PLANS AND SPECIFICATIONS

[FINAL PLANS TO BE INSERTED PRIOR TO CITY'S EXECUTION OF LEASE]

EXHIBIT F

FORM OF PERFORMANCE BOND

PERFORMANCE BOND AND PAYMENT (LABOR & MATERIALS) BOND

WHEREAS, La Cocina, Inc. ("Tenant") and the City and County of San Francisco ("City") are parties to a Lease dated as of _____, 20__ ("Lease") for the property commonly known as 101 Hyde Street, San Francisco, California ("Property"); and

WHEREAS, Tenant is required to make certain improvements to the Property pursuant to Article 6 of the Lease, and Tenant has entered into a _____ [name of contract] ("Contract") with _____ [name of contractor] ("Principal") dated as of _____, 20__, for the performance of such improvements, as further described in the Contract ("Work"); and

WHEREAS, The Lease requires that Principal furnish a Bond for the faithful performance of the Contract and to furnish a separate Bond for the payment of any materials, provisions, or other supplies, used in, upon, for or about the performance of the work contracted to be done under the Contract ("Work").

NOW, THEREFORE, we the Principal and

_____ as Surety, are firmly bound unto Tenant and the City in the penal sum of

(PERFORMANCE BOND)

(PAYMENT BOND)

_____ and _____

lawful money of the United States for the payment of which sum well and truly to be made, we bind ourselves, our heirs, executors, administrators, successors and assigns, jointly and severally firmly by these presents for the penal sum for a performance bond and an equal and separate penal sum for a separate payment bond.

(PERFORMANCE BOND)

THE CONDITION OF THIS OBLIGATION IS SUCH, that if the above bounded Principal, its heirs, executors, administrators, successors or assigns, shall in all things stand to and abide by, and well and truly keep and perform the covenants, conditions and agreements in the said Contract, including the provisions for liquidated damages in the said Contract, any changes, additions or alterations thereof made as therein provided, on its part, to be kept and performed at the time and in the manner therein specified, and in all respects according to their true intent and meaning, and shall indemnify and save harmless the City, its officers and agents, as therein stipulated, then this obligation shall become null and void; otherwise it shall be and remain in full force and effect.

(PAYMENT BOND)

THE CONDITION OF THIS OBLIGATION IS SUCH, that if Principal, its heirs, executors, administrators, successors or assigns, or its subcontractors, shall fail to pay (i) any of the persons named in California Civil Code Section 9100 for any materials, provisions, or other supplies used in, upon, for or about the performance of work under the Contract, or for any work or labor performed under the Contract; or (ii) amounts due under the California Unemployment Insurance Code with respect to work or labor performed under the Contract; or (iii) for any amounts required to be deducted, withheld, and paid over to the State of California Employment Development Department from the wages of employees of Principal and subcontractors pursuant to Section 13020 of the California Unemployment Insurance Code with respect to such work or labor, that Surety will pay for the same in an amount not exceeding the sum specified in this Bond. In the event that suit is brought upon this Payment Bond, the parties not prevailing in such suit shall pay reasonable attorney's fees and costs incurred by the prevailing parties in such suit.

This Payment Bond shall inure to the benefit of any of the persons named in California Civil Code Section 9100 as to give a right of action to such persons or their assigns in any suit brought against this Bond.

Should the condition of this Payment Bond be fully performed, then this obligation shall become null and void; otherwise, it shall be and remain in full force and effect.

Surety, for value received, hereby expressly agrees that no change, extension of time, modification, alteration or addition to the undertakings, covenants, terms, conditions and agreements of the Contract, or to the work to be performed thereunder, or to the specifications accompanying the same, and no inadvertent overpayment of progress payments, shall in any way affect its obligations on these Bonds; and it does hereby waive notice of any such change, extension of time, modification, alteration or addition to the undertakings, covenants, terms, conditions and agreements of the Contract, or to the Work to be performed thereunder, or to the specifications, or of any inadvertent overpayment of progress payments.

IN WITNESS WHEREOF, the above-bounden parties have executed this instrument under their seal this ____ day of _____, 20____, the name and corporate seal of each corporate party being hereto affixed and these presents duly signed by its undersigned representative, pursuant to authority of its governing body.

Approved as to form:
Dennis J. Herrera
City Attorney

By: _____
Deputy City Attorney

Principal

By: _____

Surety

By: _____

A notary public or other officer completing this certificate verifies only the identity of the individual who signed the document to which this certificate is attached, and not the truthfulness, accuracy, or validity of that document.

State of California)
) ss
County of San Francisco)

On _____, before me, _____, a notary public in and for said State, personally appeared _____, who proved to me on the basis of satisfactory evidence to be the person(s) whose name(s) is/are subscribed to the within instrument and acknowledged to me that he/she/they executed the same in his/her/their authorized capacity(ies), and that by his/her/their signature(s) on the instrument the person(s), or the entity upon behalf of which the person(s) acted, executed the instrument.

I certify under PENALTY OF PERJURY under the laws of the State of California that the foregoing paragraph is true and correct.

WITNESS my hand and official seal.

Signature _____ (Seal)

EXHIBIT G

STANDARD UTILITIES

The standards set forth below describe the basic utilities and services that will be in effect for the Building. City reserves the right to adopt any nondiscriminatory modifications and additions to such standards which do not materially impair Tenant's rights under this Lease or Tenant's use of the Premises. City shall give Tenant reasonable advance notice, in accordance with the provisions of this Lease, of any material modifications and additions, which shall be subject to the reasonable approval of Tenant.

Subject to the terms and conditions of this Lease, City shall provide the following basic utilities and services:

A. **Ventilation; Heating and Air-Conditioning.** Ventilation to the Building, and air-conditioning and heating to the Building in season, in conformance with approved operating hours and at such temperatures and in such amounts as City deems reasonably necessary for the comfortable occupancy of the Building, subject to applicable governmental laws, ordinances, rules and regulations. Tenant shall not alter, adjust, tamper with or in any manner affect the installations or facilities supplying climate control to the Building without City's consent.

B. **Electricity.** Electric current to the Building on a 24-hours a day, 7-days a week basis, in such quantity as is reasonably determined by City to service standard commercial restaurant lighting and normal fractional horsepower kitchen equipment. Tenant shall not connect any apparatus or device with wires, conduits or pipes, or other means by which the services are supplied, for the purpose of using additional or extraordinary amounts of the services without the prior written consent of City. At all times, Tenant's use of electric current shall not exceed the capacity of feeders to the Building or the risers or wiring installation, except as provided in working drawings to City.

C. **Water.** Water available at current points of supply in public areas for drinking and lavatory purposes only, and hot and cold water in the Building for drinking and kitchen purposes, on a 24-hours a day, 7-days a week basis.

EXHIBIT H.

RULES AND REGULATIONS

[TO BE INSERTED BY CITY AND TENANT PRIOR TO CITY'S LEASE EXECUTION]

EXHIBIT I

FIRST SOURCE HIRING AGREEMENT

[TO BE EXECUTED BY LA COCINA AND OEWD AND ATTACHED]

EXHIBIT J

MAINTENANCE AGREEMENTS

[ATTACHED, TO THE EXTENT AVAILABLE]

Mayor's Office of Housing and Community Development
City and County of San Francisco



London Breed
Mayor

Kate Hartley
Director

Memorandum

TO: Ruben Orduña, San Francisco Foundation
CC: Landon Williams, San Francisco Foundation
Joaquin Torres/Jorge Rivas/Crezia Tano, Office of Economic and Workforce Development
Andrico Penick/Josh Keene, Department of Real Estate
Mara Blitzer, MOHCD
FROM: Kate Hartley, Mayor's Office of Housing and Community Development *KH*
DATE: February 1, 2019
RE: 101 Hyde Street Interim Commercial Use – Request for Release of Funds for the
Municipal Marketplace Project.

Executive Summary

The San Francisco Foundation (SFF) is holding a \$1,000,000 Grant (the "Grant") from 1066 Market Street, LLC (affiliated with the Shorenstein Company) that the City and County of San Francisco ("City") requests to use to partially finance the improvements necessary to convert the former Post Office at 101 Hyde Street ("Site") into a small business incubator and food hall to serve the low-income residents and workers of the Tenderloin district. The Grant will provide critical money for the design and planning of the Tenant Improvements for the project and will jump-start the capital fund-raising effort needed to complete the conversion. Release of Grant funds to the City is the necessary first step in the process of making them available for disbursement by the City to La Cocina, the entity chosen through a competitive process to make use of them. La Cocina is a competent, experienced sponsor with an excellent team that has made significant progress to date. Successful implementation of their plan relies on fundraising, for which the sponsor demonstrates a strong track record.

This memo provides background information about the plans for, and status of, the proposed Municipal Marketplace project for purposes of seeking release of the Grant funds by SFF to the City. Grant proceeds will not be released to the sponsor by the City until they have demonstrated significant completion of additional fundraising.

Mayor's Office of Housing and Community Development
City and County of San Francisco

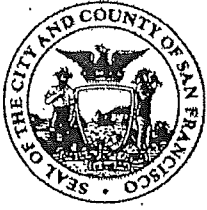

London Breed
Mayor

Kate Hartley
Director

Memorandum

TO: Ruben Orduña, San Francisco Foundation
CC: Landon Williams, San Francisco Foundation
Joaquin Torres/Jorge Rivas/Crezia Tano, Office of Economic and Workforce Development
Andrico Penick/Josh Keene, Department of Real Estate
Mara Blitzer, MOHCD
FROM: Kate Hartley, Mayor's Office of Housing and Community Development
DATE: February 1, 2019
RE: 101 Hyde Street Interim Commercial Use – Request for Release of Funds for the
Municipal Marketplace Project.

Executive Summary

The San Francisco Foundation (SFF) is holding a \$1,000,000 Grant (the "Grant") from 1066 Market Street, LLC (affiliated with the Shorenstein Company) that the City and County of San Francisco ("City") requests to use to partially finance the improvements necessary to convert the former Post Office at 101 Hyde Street ("Site") into a small business incubator and food hall to serve the low-income residents and workers of the Tenderloin district. The Grant will provide critical money for the design and planning of the Tenant Improvements for the project and will jump-start the capital fund-raising effort needed to complete the conversion. Release of Grant funds to the City is the necessary first step in the process of making them available for disbursement by the City to La Cocina, the entity chosen through a competitive process to make use of them. La Cocina is a competent, experienced sponsor with an excellent team that has made significant progress to date. Successful implementation of their plan relies on fundraising, for which the sponsor demonstrates a strong track record.

This memo provides background information about the plans for, and status of, the proposed Municipal Marketplace project for purposes of seeking release of the Grant funds by SFF to the City. Grant proceeds will not be released to the sponsor by the City until they have demonstrated significant completion of additional fundraising.

History and Background

101 Hyde Street is a one-story building located at the corner of Golden Gate Avenue and Hyde Street consisting of approximately 7,500 gross square feet, formerly used as a U.S. Postal Service office.

In August 2016, the owner of the land and the improvements at 101 Hyde Street ("Site") dedicated the Site to the City, through the Mayor's Office of Housing and Community Development ("MOHCD") for the purpose of developing 85-100 units of affordable housing. At that time an interim use of the Site was deemed appropriate to activate it in the interest of public health and safety while necessary additional funds are raised to proceed with its full development as affordable housing.

In addition to the property transfer, the Site's owner provided certain funds for the express purpose of creating housing and interim amenities at the Site. The City is grateful to the San Francisco Foundation for acting as temporary trustee of these funds.

In the Fall of 2016, the Real Estate Department ("RED") in collaboration with the Office of Economic and Workforce Development ("OEWD") and MOHCD solicited proposals for converting the Site to a community-serving, interim use. La Cocina, a non-profit 501(c)3 public benefit corporation specializing in assisting low-income entrepreneurs to launch self-sustaining food oriented micro-businesses, was selected, in association with the Tenderloin Housing Clinic ("THC"), to lease, build, manage and operate a community serving facility at the site. As La Cocina's community partner in the project, THC will lead all neighborhood outreach efforts, provide overall liaison with the Tenderloin neighborhood, and help to ensure that the project executes on its goals of community service. In addition, drawing from its own extensive experience with both rehabilitation construction projects and with City contracts and agencies THC will provide advice and technical assistance La Cocina to ensure that the construction phase of the project is completed in a timely and efficient manner and that La Cocina meets its contracting compliance requirements.

Proposed Interim Use of 101 Hyde Street: La Cocina's Municipal Marketplace

La Cocina proposes to build, manage, and operate a 7,500 square foot food hall and business incubator space low-income, local food-service entrepreneurs from the La Cocina programs and any additional capacity will be available to the community. The Municipal Marketplace will include a shared, up-to-date commercial kitchen and indoor community space with a focus on providing economic opportunity for entrepreneurs who are otherwise unable to find appropriate and affordable space to start-up a business. Food halls managed by for-profit developers charge rents that are unsustainable for small business owners, making them especially inaccessible to small start-up enterprises. Businesses at La Cocina's food hall will pay a rent based on a much smaller base fee and a much smaller percentage of sales than is typically charged at food halls managed by for-profit developers. La Cocina will also provide the facilities and common area management services. In addition, the Municipal Marketplace will include a commercial kitchen on site whereas many food halls require vendors to prepare their food off-site at an additional cost to the vendor.

The space will include kiosks for seven (7) full-time vendors and one (1) for rotating pop-ups, a full service bar which will be separate from the main space, and a large central area for seating and for community gatherings.

The Marketplace will also provide affordable and healthful eating options for Tenderloin residents and workers and a vibrant and welcoming community gathering space.

The goals of the proposed Municipal Marketplace are:

- To address the lack of equitable access to brick and mortar business ownership for low-income entrepreneurs in the Bay Area;
- To increase the number of safe, healthy and accessible community-centered spaces for Tenderloin residents; and
- To create and refine a successful economic model for business incubator space that can be replicated in ground floor retail space in future affordable housing developments.

The City will continue to own the site and lease it to La Cocina. La Cocina will sub-lease portions of the premises to vendors that are low-income, local businesses for approximately 7 years. Since their selection in December 2016, RED has worked with La Cocina to establish the terms of the lease agreement (see below).

La Cocina's Experience

From its base in San Francisco, over the last 13 years La Cocina has proven to be very successful at launching revenue-generating micro-food businesses (over 60) that have little to no start-up capital, including 26 restaurants in one of the most difficult restaurant economies in the US. La Cocina staff and clients have successfully launched businesses at Farmers' Markets, hosted street food festivals, sold food informally on the streets and innovated in the food industry. La Cocina staff has, cumulatively, over 25 years of food-industry experience and a well-connected resource base.

La Cocina has worked with participant businesses to open their businesses within far-ranging contexts. They have worked with Cushman-Wakefield to fill spaces at Crocker Galleria, with the Westfield to activate their Westfield coffee space over the holidays and with the Market on Market to launch Azalina's. La Cocina was a founding advisor for the Mission Community Market, the inspiration and the organization behind the 100,000 person San Francisco Street Food Festival, and has managed mobile vending relationships at Dolores Park and Justin Herman Plaza. Additionally, La Cocina has consulted with food truck market halls in New Orleans and Portland, supporting both through successful openings. Lastly, in preparation for the Municipal Market venture, La Cocina talked extensively with the initial management team of the Hall, a for-profit owned food hall on Market Street in the City about the plans for that shared market. El Pipila, a La Cocina graduate, is one of only two businesses that has had no turn-over in the space it occupies, a testament to the strength of support provided by La Cocina.

Lease Terms and Restrictions on Use of Grant Funds

The proposed Lease with the City includes certain provisions that control the use of Grant funds, referred to in the Lease as the "Tenant Improvement Allowance." These include the following:

- The Tenant Improvement Allowance ("Allowance") may only be used for "Reimbursable Costs", including hard costs and architecture and engineering fees associated with work that has been authorized by City-approved design or construction documents or change orders.

- The Allowance may only be used to reimburse La Cocina for work that has been completed and paid for, not for deposits or for pre-payment of work yet to be performed.
- Requests for such reimbursement must be made by way of monthly Draw Requests which must include certain documentation such as invoices, Contractor's percentage of completion estimates, proofs of payment, lien releases, etc.
- The Allowance may be used to reimburse La Cocina for up to the first \$250,000 of Reimbursable Costs after which the Allowance may pay only 50% of each Draw Request until it is exhausted.
- The City may withhold a disbursement of the Allowance until La Cocina provides evidence that it holds or has the right to receive all funds necessary to meet its obligation to match the City's disbursement.

Uses and Sources of Financing for Tenant Improvements

CAPITAL USES: \$4,700,000

As of 11/30/2018 the total cost of the conversion of 101 Hyde to a food hall was estimated to be approximately \$4,600,000. That estimate was based on 90% Construction Design, bids from Mechanical, Electrical subcontractors and consultations with Plumbing, Drywall and Painting. The figure above includes escalation to start of construction expected to occur approximately March 2019. This budget figure also includes a 9.6% construction contingency.

A detailed project Construction Budget is attached as Exhibit B

CAPITAL SOURCES: \$4,700,000

Project costs are to be paid for by a combination of public funding from the City and fund-raising by La Cocina from other private foundations, corporations and individuals.

- **City Funds: \$1,465,000**

This includes \$940,000 of the \$1M Grant that is the subject of this memo. A portion of the \$1,000,000 Grant (approximately \$60,000) is expected to be used to repay RED for costs related to the transfer of the Site, holding costs and the administration of the RFP. Additional City funds were approved in the FY17-18 and FY18-19 City budgets, to bring the total City funds to the project to \$1,465,000.

- **Other Fund-raising: : \$2,412,478 raised to date, target raise is \$3,235,000**

La Cocina has considerable experience fund-raising both for capital projects and for its on-going operations, having fund-raised at least \$1M annually for the past 13 years. Their FY18 budget is \$2.8M, of which half will be generated by events, retail and catering services and the remainder by fund-raising.

To assist with the Municipal Marketplace project, Brenda Larabee, a fund-raising consultant with nearly 30 years of experience in helping to raise money for local non-profit organizations such as Continuum HIV Day Services, SFJAZZ and Rafael House, has been engaged to work with La

Cocina's Board members, who count among their members individuals associated with the Levi Strauss Foundation and the Women's Foundation of California. La Cocina has existing relationships with several financial institutions that have provided capital and operating assistance over the past 11 years, including for example, Citibank (start-up grants in 2002, 2004, and 2006), Well Fargo (grant funding annually since 2002), JP Morgan Chase (grant funding since 2014),

La Cocina proposes to raise the remaining capital financing from a variety of foundations, corporations and individual donors. As of 1/31/2019, approximately \$2,412,478 of the projected \$3,235,000 that must be raised has already been received, approved, or pledged. The remaining \$822,522 is expected to be raised over the next 4-6 months.

While this > \$3m fund-raising goal for 101 Hyde would increase La Cocina's overall fund-raising goal for their efforts will be assisted by the fact that the Municipal Marketplace capital campaign will be associated with the one-time hard costs of an identifiable construction project which will provide a national model for similar efforts to reduce poverty and more equitable opportunities for economic growth.

La Cocina has an approved loan of \$1MM from Dignity Health to bridge the potential gap between obtaining fund-raising dollars and meeting the need for them during the construction phase of the project.

CAPITAL FINANCING		
Secured or Pledged Funding:		
Grant (MOHCD)	\$ 1,465,000	\$3,877,478
Foundations, Corporations, Individuals	\$ 1,662,478	
Community Economic Development (US Dept of Health and Human Services)	\$ 750,000	
Bridge Loan		
Dignity Health PRI (drawdown only as needed. Goal is to minimize debt.)	\$1,000,000	
TOTAL CAPITAL FINANCING AVAILABLE		\$4,877,478

In addition, La Cocina is fund-raising to include raising an additional \$300,000 for on-going program and operations at the Municipal Marketplace during its initial stages. To date, La Cocina fundraising effort has met this goal.

PROGRAM FINANCING		
Secured or Pledged Funding:		
OEWD	\$ 75,000	\$392,347
Foundations, Corporations, Individuals	\$317,347	
TOTAL PROGRAM FINANCING		\$392,347

Any excess funds raised will be utilized by La Cocina to increase programming intensity, such as a soft opening that is exclusive to the community.

Marketing and Community Support

La Cocina's municipal marketplace will follow the same marketing model as other La Cocina-incubated programs. La Cocina's current customer mailing list has 10,000 people and its social media channels have over 30,000 followers. La Cocina's 2015 Street Food Festival attracted over 80,000 attendees who demonstrated an interest in both the goods that La Cocina produces and the stories and people behind those goods. Reaching out to this active and engaged audience will be the first step for marketing the food hall.

Marketing efforts will begin within the community that the Marketplace is intended to serve. La Cocina plans a soft opening with an exclusive focus on residents and neighborhood workers before extending the food hall's doors to the broader community. Working with Tenderloin community organizations with which it already has relationships, La Cocina will host events, offer discounted space and ensure that the Municipal Marketplace becomes a resource to the community.

As it has successfully done in other locations, La Cocina, along with its vendors will then continue to build sales by actively reaching out to local institutions such as Hastings, local non-profits, the San Francisco legal community and City Hall to increase lunch foot traffic and will engage the assistance of PR professionals and use social media to reach additional customers.

The Municipal Marketplace proposal has generated support from numerous non-profit, private and public sector organizations, including many that are active in the Tenderloin neighborhood such as the Tenderloin Housing Clinic (a co-sponsor and partner), St. Anthony's, Tenderloin Neighborhood Development Corporation, 826 Valencia, Mercy Housing, Tenderloin Healthy Corner Store Coalition, and Root Division. Other supporting community-based and public-sector supporters include Mission Economic Development Agency, Urban Solutions, Hastings College of Law, City College's School of Arts and Hospitality Studies, San Francisco's Office of Small Business, Restaurant and Hotel Workers' Union Local 2, and the Mayor's Offices of Economic and Workforce Development and of Housing and Community Development

Project Milestones and Status

The Development Team (Architect, Contractor, Owner's Construction Representative) for the Municipal Marketplace project has been selected. La Cocina hired an in-house Project Manager to take over day to day management of the overall project, beginning in summer 2018.

Architect:	Perkins and Will (primary architect) LMNOP Design (design-build)
Contractor:	BCCI Builders
Owner's Construction Representative:	Pound Management

Tenant-Improvements Design and Permitting: As of 11/30/2018

Conceptual Design - Complete
Schematic Design - Complete
Design Development - Complete
Construction Documents ("CDs") - 90% Complete.

La Cocina has held a Pre-Application meeting with DBI to insure that the project can get an Over-the-Counter ("OTC") Permit. Additionally, the team received their MOD approval. Since the proposed use of 101 Hyde as a Retail Sales and Service (Restaurant) is a permitted use, approval by the planning department can be obtained over-the-counter.

Construction (demolition) is expected to commence in May 2019 to be completed approximately 21 weeks later.

A detailed project Construction Budget is attached as Exhibit B. (Updated version will be sent 2/1. It will be 2 months pushed out from the 11/18 version)

Next Steps

Upon receipt of approval to disburse funds from San Francisco Foundation, MOHCD/OEWD/RED will proceed with seeking approvals from the Board of Supervisors to continue moving the project forward. Two resolutions will be introduced to the Board, an approval of the Terms of Lease and an approval to Accept and Expend funds from the San Francisco Foundation. It is expected to take approximately 6 weeks for the City's review and approval of these Resolutions, which will be introduced in January 2018. Following these approvals, the City intends to enter into the Lease with La Cocina, facilitating the start of site renovations once La Cocina has raised the funds necessary to do so.

Recommendation:

MOHCD recommends SSF approval of the release of Grant funds subject to the City's approval of the acceptance of those funds to facilitate the signing of a Lease and initiation of the Municipal Marketplace project at 101 Hyde.

1. Exhibits:

- A. A Food Hall for All
- B. Construction Budget detail (see separate Excel File)
- C. Project Milestones/Schedule (see separate Excel File)
- D. Parcel Map (see Exhibit B of RED RFP)
- E. Rendering and Floor Plans (11/20/18 version).



LA COCINA

101 Hyde Street Market Hall Project



Preliminary Budget						
#	Description	Current Budget	Invoiced to Date	%	Balance	Notes
2.00	Design & Engineering					
2.01	Surveyor	0	0	0%	0	
2.02	Geotechnical Engineer	0	0	0%	0	
2.03	Civil Engineering: Luk and Associates	0	0	0%	0	Agreed to provide services pro bono per call with TP 3/7/18
2.04	Architectural Design: Perkins + Will	0	0	0%	0	Agreed to provide services pro bono per call with TP 3/7/18
2.05	Interior Design: LAINOP	58,625	0	0%	58,625	per Agreement dated 3/16/17
2.06	Structural Engineering: FTF Engineering	25,000	0	0%	25,000	per TP budget dated 11/14/17
2.07	Mechanical Engineer Innovative	0	0	0%	0	Costs under BCCI (line 4.02)
2.08	Electrical Engineer: MacMillan	0	0	0%	0	Costs under BCCI (line 4.02)
2.09	Plumbing Engineer: Ayoub	0	0	0%	0	Costs under BCCI (line 4.02)
2.10	Commissioning	0	0	0%	0	
2.11	Hardware Consultant	0	0	0%	0	
2.12	Fire Consultant	0	0	0%	0	
2.13	Furniture Design	0	0	0%	0	
2.14	Spec Writer	0	0	0%	0	
2.15	Vertical Transport	0	0	0%	0	
2.16	A/V / Acoustical Workstage	0	0	0%	0	Potential for pro bono work on both design and components per TP call 3/7/18
2.17	Life Safety / Codes	0	0	0%	0	Costs under BCCI
2.18	Kitchen Designer: Myers/KRBS	0	0	0%	0	Costs under BCCI (line 4.02)
2.19	Lighting Designer	0	0	0%	0	Costs under BCCI (line 4.02)
2.20	IT Consultant	0	0	0%	0	TP has the firm "OFFICE" lined up and they will do pro bono work at no cost
2.21	Waterproofing	0	0	0%	0	
2.22	Other Design Consultants	0	0	0%	0	
2.23	Design & Engineering Reimbursables	0	0	0%	0	
	Sub-total:	83,625	0	0%	83,625	
3.00	Permits and Utilities:					
3.01	Planning Approvals	0	0	0%	0	BCCI consultant included in 11/14/17 BCCI budget, permit expeditor working pro bono
3.02	Building, Grading Permits & Impact Fees	0	0	0%	0	Included in 11/14/17 BCCI budget, not shown to prevent double counting
3.03	Environmental Inspector: Al Clancy	0	0	0%	0	
3.04	Health Department	0	0	0%	0	
3.05	School Fees:	0	0	0%	0	
3.06	Telephone & Data	0	0	0%	0	
3.07	Water System/Connection Fees	24,386	0	0%	24,386	2" CW supply. Rates per SF Water Power & Sewer Rate Schedule - 2017/2018
3.08	Septic System/Connection Fees	0	0	0%	0	Fees not included because septic system is not changing
3.09	PG&E Upgrade	0	0	0%	0	Included in BCCI budget
3.10	SWPPP:	0	0	0%	0	
3.11	Other Fees & Permits:	0	0	0%	0	
	Sub-total:	24,386	0	0%	24,386	
4.00	Construction Hard Costs:					
4.01	General Contractor - Pre-Construction BCCI	39,244	0	0%	39,244	per Pre-Construction Agreement dated 2/20/18
4.02	General Contractor - GMP	3,898,856	127,859	3%	3,770,997	per BCCI Final Pricing Dated 1/23/19
4.03	Civil Contractor	0	0	0%	0	
4.04	Independent Testing & Inspections:	0	0	0%	0	
4.05	Arbors:	0	0	0%	0	
4.06	Signage	75,000	0	0%	75,000	per 11/14/17 budget created by TP, confirmed on 3/6/18
4.07	Fire Alarm + Sprinklers:	0	0	0%	0	
4.08	A/V / Low Voltage:	0	0	0%	0	
4.09	Owner Supplied Items	0	0	0%	0	
4.10	Other Contractors	0	0	0%	0	
4.11	Construction Escalation	0	0	0%	0	
4.12	Construction Security	0	0	0%	0	
	Sub-total:	4,013,100	127,859	3%	3,885,241	
5.00	Furniture, Fixtures & Equipment:					
5.01	Telephone Systems:	0	0	0%	0	No phone system to be installed
5.02	Computer Systems & Office Equipment	0	0	0%	0	Cobb is exploring Square as a potential donor
5.03	Audio / Visual Systems	0	0	0%	0	Will include projection screens, custom lighting fixture, and sounds system - not yet priced
5.04	Kitchen Equipment	0	0	0%	0	\$350,000 value - to be donated
5.05	Special Equipment	0	0	0%	0	
5.06	Window Treatments, Rugs, Etc.	0	0	0%	0	
5.07	Decorative Lighting	0	0	0%	0	
5.08	Fixtures and Furniture	87,000	0	0%	87,000	Items to be donated per notes in TP budget of 11/17/17 including tables and chairs
5.09	Artwork/ Wall Treatment:	65,000	0	0%	65,000	per 11/14/17 budget created by TP, confirmed on 3/6/18
5.10	Internet Services	0	0	0%	0	Confirm with TP, needed for event space rental
5.11	Other Furniture, Fixtures & Equipment	0	0	0%	0	
	Sub-total:	152,000	0	0%	152,000	
6.00	Administration:					
6.01	Project Management: Pound Management Inc.	50,000	37,313	75%	12,688	
6.02	Insurance, Builders Risk	20,000	0	0%	20,000	
6.03	Legal Fees:	0	0	0%	0	
6.04	Plans & Document Control	0	0	0%	0	
6.05	Finance Expense:	0	0	0%	0	
6.06	Temporary Facilities	0	0	0%	0	
6.07	Administration Reimbursables	0	0	0%	0	
	Sub-total:	70,000	37,313	53%	32,688	
	Total Project Costs:	4,303,110	165,171	4%	4,137,940	
4.02	Proposed Project Contingency percentage of project budget	\$ 256,889 5.98%	\$ 560,00	0%	256,889	
	Project Budget Subtotal	4,600,000	165,731	1%	4,434,270	

La Cocina
101 Hyde Street Municipal Market Hall
San Francisco CA, 94110

La Cocina Schedule 11.1.1.1.mpp
Status Date: 10/23/18
Printed: 10/18/18 (1:35 PM)

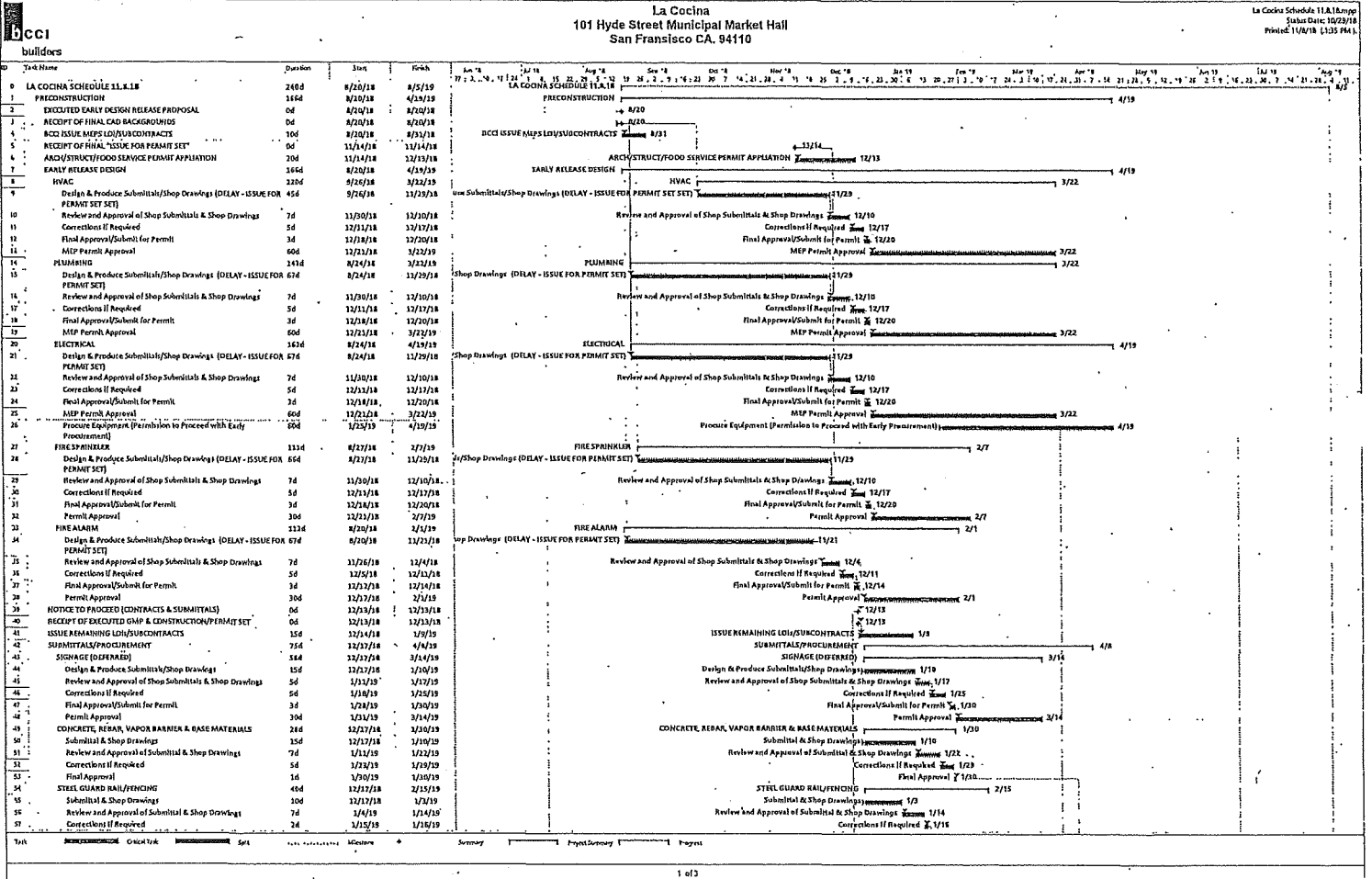

La Cocina
101 Hyde Street Municipal Market Hall
San Francisco CA, 94110

La Cocina Schedule 11.8.18.mpp
Sheet Date: 10/29/18
Printed: 11/01/18 (1:23 PM)

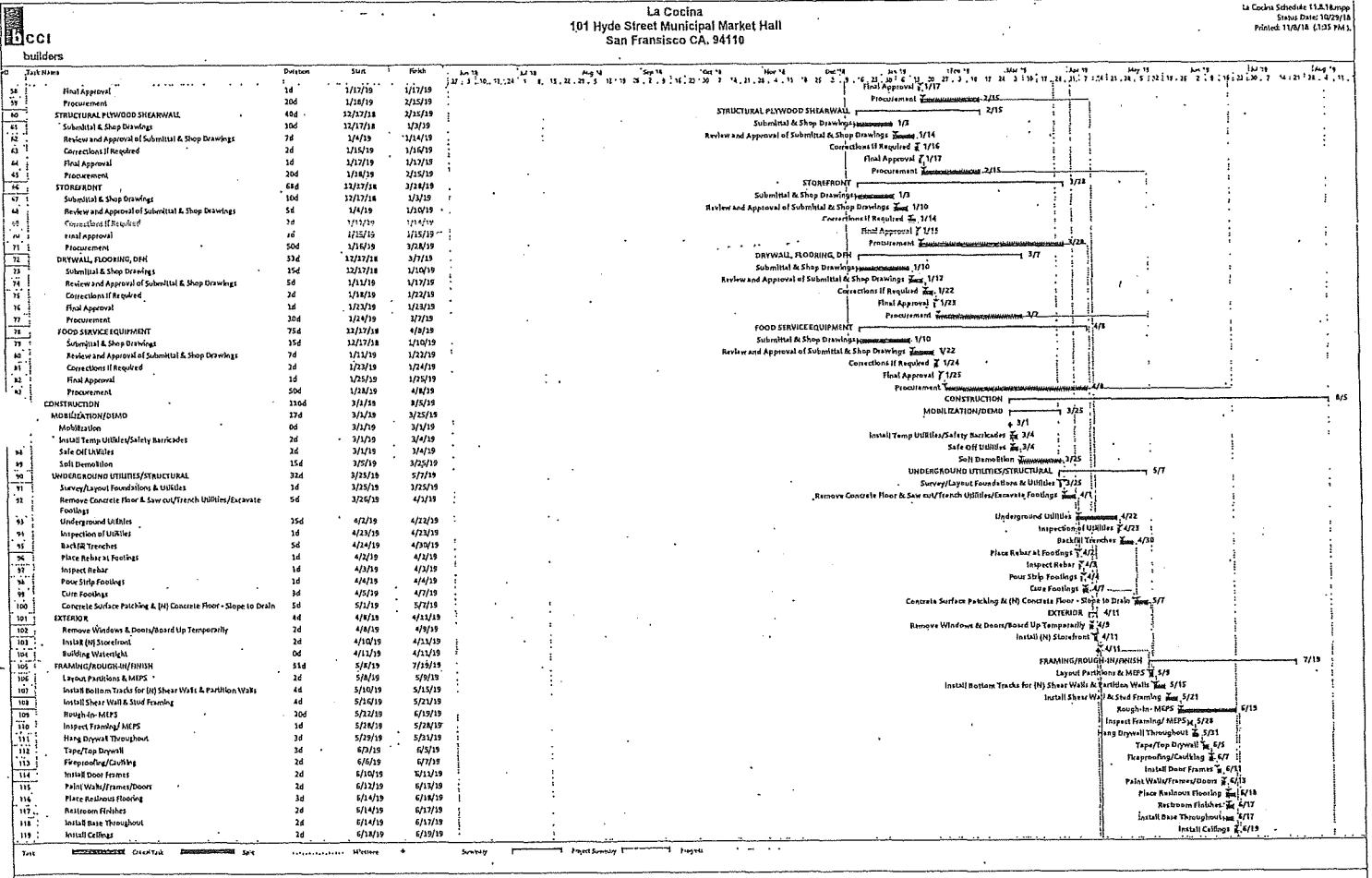

101 Hyde Street – Parcel Maps

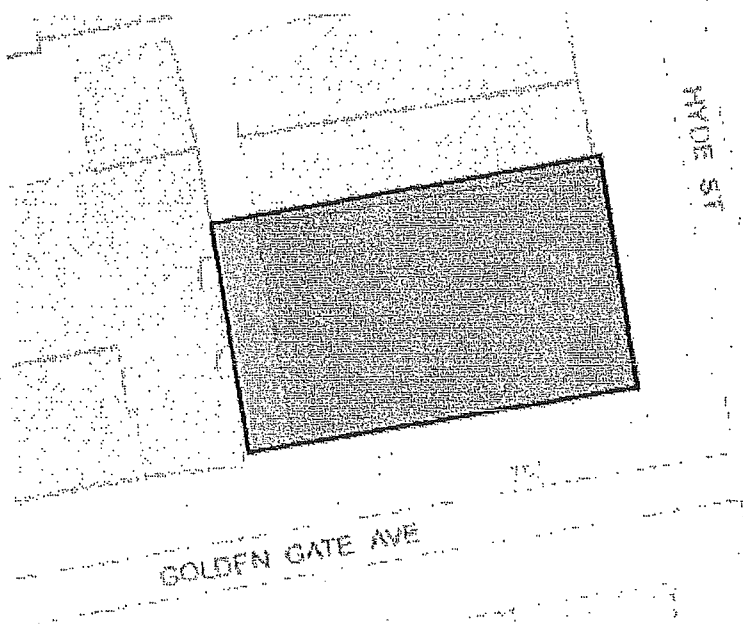
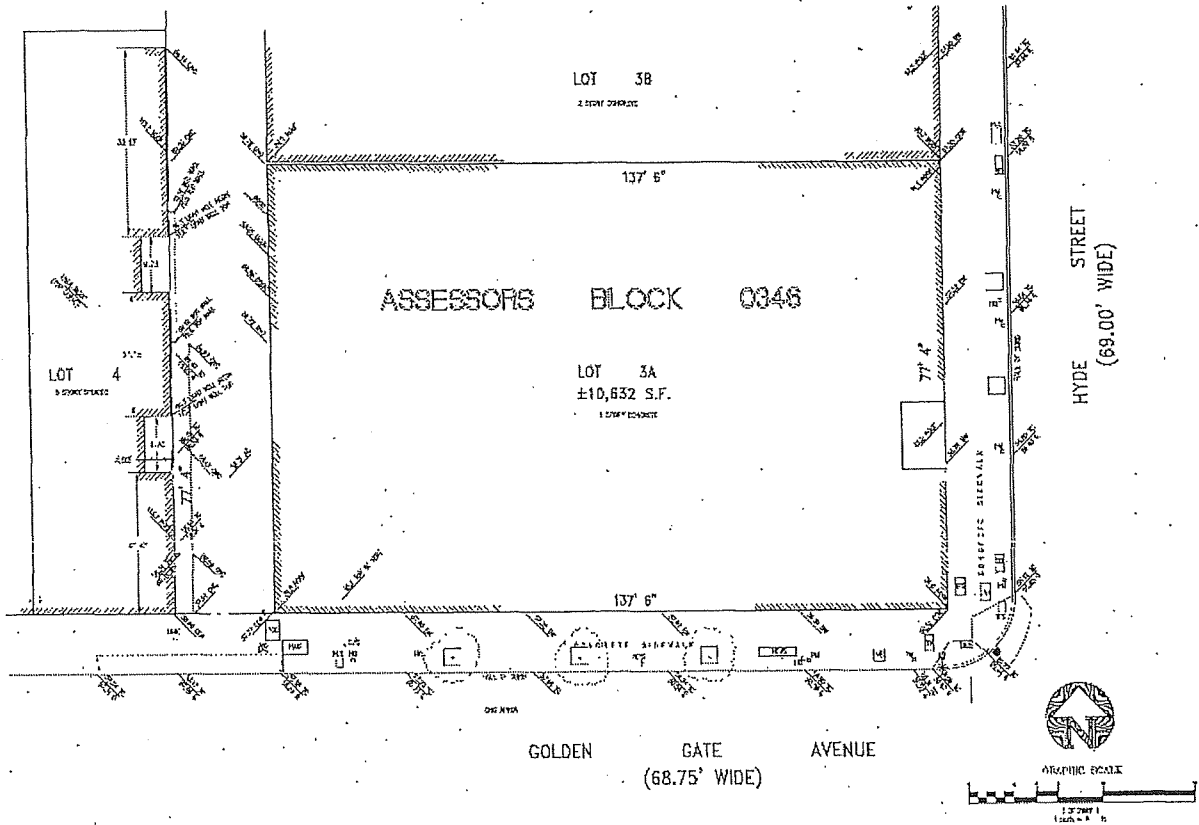

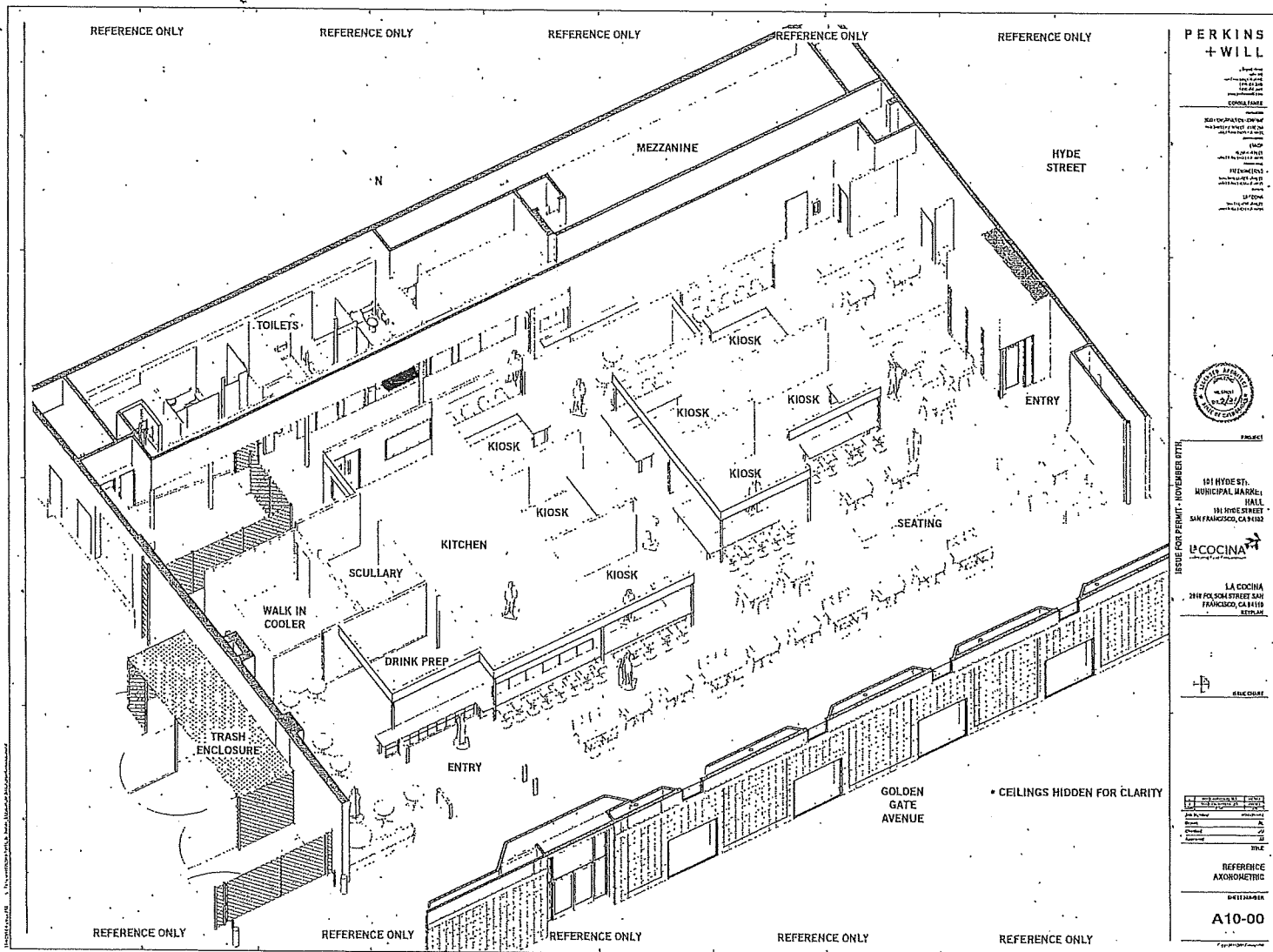

PERKINS + WILL

ARCHITECTS

100 MADISON AVENUE

NEW YORK, NY 10017

TEL: 212 512 2000

FAX: 212 512 2001

WWW.PW.COM



PROJECT

151 HYDE ST.
MUNICIPAL MARKET HALL
151 HYDE STREET
SAN FRANCISCO, CA 94102

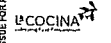

LA COCINA
2419 POLSON STREET SAN FRANCISCO, CA 94118
RETN, CA

DATE

NO.	DESCRIPTION	DATE
1	ISSUE FOR PERMIT - NOVEMBER 07/00	11/07/00
2		
3		
4		
5		
6		
7		
8		
9		
10		

REFERENCE AXONOMETRIC

DATE: 11/07/00

A10-00

LEASE

between

CITY AND COUNTY OF SAN FRANCISCO,
as Landlord

and

LA COCINA, INC.,
as Tenant

For the lease of
101 Hyde Street
San Francisco, California

June 1, 2018

LEASE

THIS LEASE (this "Lease"), dated for reference purposes only as of June 1, 2018, is between the CITY AND COUNTY OF SAN FRANCISCO, a municipal corporation ("City"), and LA COCINA, INC., a California non-profit corporation ("Tenant").

City and Tenant hereby covenant and agree as follows:

1. BASIC LEASE INFORMATION

The following is a summary of basic lease information (the "Basic Lease Information"). Each item below shall be deemed to incorporate all of the terms in this Lease pertaining to such item. In the event of any conflict between the information in this Section and any more specific provision of this Lease, the more specific provision shall control.

Lease Reference Date:	June 1, 2018
Landlord:	CITY AND COUNTY OF SAN FRANCISCO, a municipal corporation
Tenant:	La Cocina, Inc. (and any permitted successors and assigns)
Building (<u>Section 2.1</u>):	Building located at 101 Hyde Street San Francisco, California ("Building")
Premises (<u>Section 2.1</u>):	The real property commonly known as 101 Hyde Street (Assessor's Block 0346 / Lot 003A ("Property"), as more particularly described and shown on <u>Exhibit A</u> , together with the Building and any other improvements located thereon
Rentable Area of Premises (<u>Section 2.1</u>):	Approximately 7,500 gross square feet
Term (<u>Section 3.1</u>):	Year to year term commencing on the full execution of this Lease ("Effective Date").
Base Rent (<u>Section 4.1</u>):	Annual Base Rent: \$12,000.00 Monthly payments: \$1,000.00
Percentage Rent (<u>Section 4.2</u>):	Annual payments ("Percentage Rent") equal to five percent (5%) of Net Income (as defined in <u>Section 4.2</u>)
Use (<u>Section 5.1</u>):	Operation of a restaurant, bar, and/or market hall, or any other legal use approved in advance by the Director of Property in consultation with the Director of City's Office of Workforce and Economic Development ("OEWD").
Tenant Improvements (<u>Section 6.1</u>):	Tenant shall perform, at its sole cost, the Tenant Improvements (as defined in <u>Section 6.1</u>).

Utilities and Services (Section 10.1):

City shall provide the Standard Utilities (as defined in Section 10.1) and the Fire and Alarm System Maintenance (as defined in Section 10.1); provided, however, that Tenant shall reimburse City for such costs. Tenant shall provide, at its sole cost, all other utilities and services it wishes to receive at the Premises.

Security Deposit:

None.

Notice Address of City (Section 27.1):

Real Estate Division
25 Van Ness Avenue, Suite 400
San Francisco, California 94102
Attn: Director of Property
Re: **101 Hyde Street – La Cocina Lease**
Fax No.: (415) 552-9216

with a copy to:

Office of Economic and Workforce Development
City Hall, Room 448
1 Dr. Carlton B. Goodlett Place
San Francisco, CA 94102-4653
Attn: Juan Carlos Cancino
Re: **101 Hyde Street – La Cocina Lease**

and to:

Office of the City Attorney
City Hall, Room 234
1 Dr. Carlton B. Goodlett Place
San Francisco, California 94102-4682
Attn: Carol Wong
Deputy City Attorney
Re: **101 Hyde Street – La Cocina Lease**
Fax No.: (415) 554-4757

Key Contact for City:

Josh Keene

Telephone No.:

(415) 554-9859

Alternate Contact for City:

Juan Carlos Cancino

Telephone No.:

(415) 554-5185

Address for Tenant (Section 27.1):

2948 Folsom Street
San Francisco, CA 94110

Key Contact for Tenant:

Caleb Zigas

Telephone No.:

(415) 824-2729 x 304

Alternate Contact for Tenant:

Leticia Landa

Telephone No.:

(415) 824-2729

Brokers (Section 27.8):

None.

101 Hyde St.

2

506

2. PREMISES; AS IS CONDITION

2.1 Lease Premises

Subject to the provisions of this Lease, City leases to Tenant and Tenant leases from City those premises identified in the Basic Lease Information (the "Premises"). The rentable area of the Premises specified in the Basic Lease Information shall be conclusive for all purposes hereof. The Premises shall include the Property, the Building, and all other improvements on and appurtenances to the Property.

2.2 Accessibility Disclosures

(a) California Civil Code Section 1938 requires commercial landlords to disclose to tenants whether the property being leased has undergone inspection by a Certified Access Specialist ("CAsp") to determine whether the property meets all applicable construction-related accessibility requirements. The law does not require landlords to have the inspections performed. Tenant is hereby advised that the Premises have not been inspected by a CAsp.

(b) Tenant acknowledges that prior to the execution of this Lease, City provided Tenant with, and Tenant signed, the Disability Access Obligations Notice described in Section 38.3 of the San Francisco Administrative Code. Tenant and City each agree to use reasonable efforts to notify the other party if making any Alterations (as defined in Section 7.1 (Tenant's Alterations)) that might impact accessibility to the Premises under any disability access laws.

2.3 As Is Condition

TENANT ACKNOWLEDGES AND AGREES THAT THE PREMISES ARE BEING LEASED AND ACCEPTED IN THEIR "AS IS" CONDITION, WITHOUT REPRESENTATION OR WARRANTY OF ANY KIND, AND SUBJECT TO ALL APPLICABLE LAWS, RULES AND ORDINANCES GOVERNING THEIR USE, OCCUPANCY AND POSSESSION. TENANT REPRESENTS AND WARRANTS TO CITY THAT TENANT HAS INVESTIGATED AND INSPECTED, EITHER INDEPENDENTLY OR THROUGH AGENTS OF TENANT'S OWN CHOOSING, THE CONDITION OF THE PREMISES AND THE SUITABILITY OF THE PREMISES FOR TENANT'S INTENDED USE. TENANT HAS DETERMINED, BASED SOLELY ON ITS OWN INVESTIGATION, THAT THE PREMISES ARE SUITABLE FOR TENANT'S BUSINESS AND INTENDED USE. TENANT ACKNOWLEDGES AND AGREES THAT NEITHER CITY NOR ANY OF ITS AGENTS HAVE MADE, AND CITY HEREBY DISCLAIMS, ANY REPRESENTATIONS OR WARRANTIES, EXPRESS OR IMPLIED, CONCERNING THE RENTABLE AREA OF THE PREMISES, THE PHYSICAL OR ENVIRONMENTAL CONDITION OF THE PREMISES, THE PRESENT OR FUTURE SUITABILITY OF THE PREMISES FOR TENANT'S BUSINESS, THE PRESENCE OR ABSENCE OF ANY HAZARDOUS MATERIALS, OR ANY OTHER MATTER WHATSOEVER RELATING TO THE PREMISES, INCLUDING, WITHOUT LIMITATION, ANY IMPLIED WARRANTIES OF MERCHANTABILITY OR FITNESS FOR A PARTICULAR PURPOSE.

2.4 Access Easements

The Property is subject to pedestrian and vehicular access easements that benefit the properties commonly known as 125 Hyde Street and 129 Hyde Street in San Francisco, California, as further described in the grant deeds recorded in the Official Records of San Francisco County at Book 2378 Page 191, Book 3846 Page 230, and Book 2162 Page 285, and as amended by the Easement Amendment and Agreements (together, the "Amended Easement Agreements") recorded in the Official Records of San Francisco County on August 5, 2016, as Instrument No. 2016-K302894 and Instrument No. 2016-K302895.

Tenant acknowledges and agrees that it has received a copy of the Amended Easement Agreements, and the easement area described in the Amended Easement Agreements (the "Easement Area") is subject to the Permitted Uses (as defined in the Amended Easement Agreements) at all times except during limited closure periods permitted under the Amended Easement Agreements. Tenant shall obtain the prior written consent of City and all the fee owners of 125 Hyde Street and 129 Hyde Street before taking any action that limits or negatively impacts the use of the Easement Area for the Permitted Uses.

3. TERM

3.1 Lease Term

The Premises are leased for a term (the "Term") commencing on the Effective Date continue on a year to year basis; provided, however, (i) the Term shall not extend beyond the Outside Date (as defined in Section 3.2), and (ii) either party shall have the right to terminate this Lease by delivering written notice of such termination to the other party at least one hundred eighty (180) days before the anniversary of the Effective Date that immediately follows the delivery of such notice. City shall deliver the Premises to Tenant on the Effective Date in their then existing as is condition as further provided above, with no obligation of the City to make any improvements, repairs or alterations.

3.2 Confirmation of Rent Commencement Date and Outside Date

The "Rent Commencement Date" shall be the date the Tenant Improvement Work (as defined in Section 6.1) is completed and City's Department of Building Inspection has issued a temporary certificate of occupancy for the Building, and the "Outside Date" shall be the seventh (7th) anniversary of the Rent Commencement Date. Promptly following the Rent Commencement Date, Tenant shall deliver to City a notice substantially in the form attached hereto as Exhibit D, confirming the actual Rent Commencement Date and the Outside Date, but Tenant's failure to do so shall not affect the date of either the Rent Commencement Date or the Outside Date.

4. RENT

4.1 Base Rent

Throughout the Term beginning on the Rent Commencement Date, Tenant shall pay to City the annual Base Rent specified in the Basic Lease Information (the "Base Rent"). The Base Rent shall be paid to City in advance, without prior demand and without any deduction, setoff or counterclaim whatsoever, in equal consecutive monthly payments on or before the first day of the Term and on or before the first day of each month thereafter. If the Rent Commencement Date occurs on a day other than the first day of a calendar month, or this Lease terminates on a day other than the last day of a calendar month, then the Base Rent for such fractional month shall be prorated based on a thirty (30) day month. Within five (5) days after the Rent Commencement Date, Tenant shall pay to City the Base Rent for the month in which the Rent Commencement Date occurs and the following month.

4.2 Percentage Rent

(a) Definitions

(i) "Books and Records" means all of Tenant's (and each of its Agent's) books, records, and accounting reports or statements relating to its business at or use of the Premises, this Lease, the Tenant Improvements, any Alterations, and the operation and maintenance of the Premises, including, without limitation, cash journals, rent rolls, general ledgers, income statements, bank statements, income tax schedules relating to Tenant's business in or use of the Premises, and any other bookkeeping documents Tenant utilizes in its business

operations for the Premises. Tenant shall maintain a separate set of accounts to allow a determination of all Operating Expenses, all Operating Income generated directly from the Premises, and all exclusions therefrom.

(ii) "Lease Year" means the twelve (12) month period immediately following the Rent Commencement Date or any anniversary of the Rent Commencement Date.

(iii) "Net Income" means the Operating Income less the Expenses for a Lease Year (or portion thereof).

(iv) "Operating Expenses" means the following reasonable operating and routine maintenance and repair expenses incurred in the operation of the Premises for the uses permitted under this Lease and performing Tenant's obligations under this Lease: (1) commercially-reasonable administrative, payroll, security and general expenses for the Premises; (2) charges for utility services; (3) expenses for repair and maintenance of equipment and furnishings; (4) expenses for routine maintenance and repair of and for cleaning the Premises, including, without limitation, expenses related to vandalism or other damage to the Premises or Tenant's equipment or supplies at the Premises; (5) the cost of supplies and equipment reasonably necessary for the operation of the Premises for the uses permitted under this Lease; (6) license and permit fees not related to the Tenant Improvements or any Alterations; (7) the cost of the insurance policies that Tenant must carry under Article 19 below or to comply with applicable laws to otherwise reasonably insure Tenant against liability relating to the management and operation of the Premises, including workers' compensation insurance, fidelity and surety bonds, casualty insurance, business interruption insurance, and any deductible amounts required under such insurance policies; (8) sales taxes, payroll taxes and all other taxes resulting from operation of the Premises; (9) possessory interest taxes; (10) other expenses incurred by Tenant under this Lease other than the payment of Base Rent or Percentage Rent; (11) the cost of utilities incurred in connection with the use and operation of the Premises; (12) costs and fees of independent professions (including, without limitation, legal, accounting, consultants and other professional expenses), technical consultants, operational experts (including quality assurance inspectors) or other third parties retained to perform services required or permitted hereunder, except to the extent incurred with respect to the design or installation of the Tenant Improvements; and (13) all other costs and expenses that are reasonable and customary operating and maintenance expenses incurred in the operation, leasing, marketing and maintenance of the Premises for the Permitted Use and in compliance with this Lease and approved by City's Director of Property in writing. Operating Expenses shall not include any charges or allowances for depreciation or amortization of Tenant's interest in the Premises or any costs or expenses incurred by Tenant as a result of any default of its obligations under this Lease.

(v) "Operating Income" means, subject only to the exceptions stated below, all sales, payments, revenues, income, fees, rentals, receipts, proceeds and amounts of any kind whatsoever, whether for cash, credit or barter, received or receivable by Tenant from any business, use or occupation (but not those received or receivable by any of its subtenants or Vendors, as defined in Section 16.1 below), or any combination thereof, transacted, arranged or performed, in whole or in part, on the Premises, including without limitation, all returns and refunds, employee meals, discounted and complimentary meals, beverages and services or similar benefits and/or goodwill, the total value, based on price, for the tickets, cover charges, merchandise and any other items and the operation of any event, including any special or fundraising event, and catering or food delivery business conducted by, from or at the Premises (irrespective of where the orders therefor originated or are accepted and irrespective of where the food or beverages are consumed). Except as specified below, Operating Income shall be determined without reserve or deduction for failure or inability to collect (including, without limitation, spillage and waste) and without deduction or allowance for cost of goods sold or other costs, charges or expenses of purchasing or selling incurred by Tenant. No value added tax, no franchise or capital stock tax and no income, gross receipts or similar tax based upon income,

profits or gross receipts as such shall be deducted from Operating Income. The following shall be excluded from Operating Income, provided that, Tenant provide separate records to City to support such deductions or exclusions, as the case may be, and separate notations are made for same on the Annual Statements (as defined in Section 4.2(b)):

(A) The amount of any refund made or credit allowed due to a bona fide complaint from a customer concerning the quality of food, beverages, merchandise or service by Tenant;

(B) Sales by redemption of gift certificates or like vouchers, but only to the extent previously reported as part of Operating Income;

(C) Sums collected for any sales or excise tax imposed directly upon Tenant by any duly constituted governmental authority, but only if stated separately from the selling price of the goods or merchandise, or services, and collected from customers and such amounts are in fact paid to the appropriate governmental entities for which they are collected; and

(D) All food and beverage sales to employees of Tenant, not to exceed, however, one percent (1%) of Operating Income in any single month, and provided further that said sales are at a discount; and

(E) Tips paid to Tenant's employees by its customers, so long as such tips go directly to Tenant's employees (and not Tenant or Tenant's management); and

(F) Bona fide promotional discounts to Tenant's customers for food, beverages and other sales, up to a maximum of five percent (5%) of Operating Income in any single month.

(b) Annual Statements

On or before the sixtieth (60th) day immediately following each anniversary of the Rent Commencement Date, Tenant shall deliver a complete statement (each, an "Annual Statement") showing the computation of the Percentage Rent for the immediately preceding Lease Year in a form approved by City. If this Lease does not terminate on an anniversary of the Rent Commencement Date, then on or before the sixtieth (60th) day immediately following such termination, Tenant shall deliver an Annual Statement showing the computation of the Percentage Rent for the period between such termination date and the anniversary of the Rent Commencement Date that immediately preceded such termination. Each Annual Statement shall set forth in reasonable detail the Operating Income for the immediately preceding Lease Year (or partial Lease Year, as applicable), including an itemized list of any and all deductions or exclusions from Operating Income that Tenant may claim and which are expressly permitted under this Lease, the Operating Expenses for the immediately preceding Lease Year (or partial Lease Year, as applicable), and a computation of the Percentage Rent for the immediately preceding Lease Year (or partial Lease Year, as applicable). Each Annual Statement shall be certified as accurate, complete and current by an independent certified public accounting firm acceptable to City's Director of Property in his or her sole discretion.

If Tenant fails to deliver any Annual Statement within the time period set forth in this subsection (irrespective of whether any Percentage Rent is actually paid or due to City for the preceding Lease Year or portion thereof, as applicable) and such failure continues for three (3) days after the date Tenant receives (or refuses receipt of) written notice of such failure from City, City shall have the right, among its other remedies under this Lease, to employ a certified public accountant to make such examination of Tenant's Books and Records (and the Books and Records of any other occupant of the Premises) as may be necessary to certify the amount of the Operating Income and Operating Expenses for the period in question. Such certification shall be

binding upon Tenant and Tenant shall promptly pay to City the total reasonable cost of the examination and City's other reasonable costs (including attorneys' fees) in exercising its examination rights hereunder, together with the full amount of Percentage Rent due and payable for the period in question. Tenant acknowledges that the late submittal of any Annual Statement will cause City increased costs not contemplated by this Lease, the exact amount of which will be extremely difficult to ascertain. The parties agree that the charges set forth in this Section represent a fair and reasonable estimate of the cost that City will incur by reason of Tenant's lateness.

(c) Payments

On or before the one hundred twentieth (120th) day immediately following each anniversary of the Rent Commencement Date, Tenant shall pay to City, in addition to the monthly Base Rent payable by Tenant pursuant to Section 4.1 above, Percentage Rent for the Lease Year immediately preceding such payment date. Notwithstanding anything to the contrary in the foregoing sentence, if this Lease terminates prior to the anniversary of a Rent Commencement Date, Tenant shall pay to City a final payment of Percentage Rent on or before the sixtieth (60th) day immediately following such termination, which payment shall be in an amount equal to five percent (5%) of the Net Income for the period (i) between the last anniversary of the Rent Commencement Date before such termination date and (ii) the termination of this Lease.

City's acceptance of any monies paid to City by Tenant as Percentage Rent as shown by the applicable Annual Statement shall not be an admission of the accuracy of such Annual Statement or the amount of such Percentage Rent payment. City's receipt of a portion of Tenant's Net Income as Percentage Rent shall be deemed strictly as rental and nothing herein shall be construed to create the legal relation of a partnership or joint venture between City and Tenant.

(d) Books and Records

Tenant agrees that the business of Tenant upon the Premises shall be operated with a non-resettable register and so that a duplicate dated sales slip or such other recording method reasonably acceptable to City is issued with each sale, whether for cash, credit or exchange. Furthermore, Tenant shall keep (and shall cause its subtenants and assignees to keep) at the Premises, at all times between the Rent Commencement Date and the termination of this Lease, complete and accurate Books and Records that contain all information required to permit City to verify Operating Income, deductions and exclusions therefrom, and Operating Expenses that are in accordance with this Lease and with generally accepted accounting practices consistently applied from period to period with respect to all operations of the business to be conducted in or from the Premises. Tenant shall retain (and shall cause its subtenants and assignees to retain) such Books and Records for a period (the "Audit Period") that is the later of (i) four (4) years after the end of each Lease Year (or portion thereof) to which such Books and Records apply or, (ii) if an audit is commenced or if a controversy should arise between the parties hereto regarding the Percentage Rent payable hereunder, until such audit or controversy is terminated.

(e) Audit

Tenant shall make its Books and Records available to City, any City auditor, or any auditor or representative designated by City (each referred to in this subsection as "City's Audit Representative"), on no less than fifteen (15) business days' prior written notice to Tenant, for the purpose of examining said Books and Records to determine the accuracy of Tenant's reporting of Percentage Rent for a period not to exceed the Audit Period after a Percentage Statement is delivered to City. Tenant shall cooperate with the City's Audit Representative during the course of any audit, provided however, such audit shall occur at

Tenant's business office, or at such other location in San Francisco where the Books and Records are kept, and no books or records shall be removed by City's Audit Representative without the prior express written consent of Tenant (provided, however, copies may be made by City's Audit Representative on site), and once commenced, with Tenant's cooperation, such audit shall be diligently pursued to completion by City within a reasonable time of its commencement, provided that Tenant makes available to City's Audit Representative all the relevant Books and Records in a timely manner. If an audit is made of the Books and Records and City claims that errors or omissions have occurred, the Books and Records shall be retained by Tenant and made available to City's Audit Representative until those matters are expeditiously resolved with Tenant's cooperation. If Tenant operates the Premises through one or more subtenants or Agents, Tenant shall require each such subtenant or Agent to provide City with the foregoing audit right with respect to its Books and Records. Upon completion of the audit, City shall promptly deliver a copy of the audit report to Tenant.

If an audit reveals that Tenant has understated its Net Income for the applicable audit period, Tenant shall pay City, promptly upon demand, the difference between the Percentage Rent payment Tenant has paid and the Percentage Rent payment it should have paid to City, plus interest from the date of the error in the payment equal to ten percent (10%) per year or, if a higher rate is legally permissible, the highest rate an individual is permitted to charge under applicable law, if City elects to charge such interest. If an audit reveals that Tenant has overstated its Net Income for the applicable audit period, Tenant shall be entitled to a credit equal to the difference between the amount Tenant has paid and the amount it should have paid to City against the next installment of Percentage Rent owed by Tenant. If Tenant understates the Net Income for any audit period by three percent (3%) or more, Tenant shall pay the reasonable cost of the audit. A second understatement of three percent (3%) or more within any three (3) Lease Year period of the first such understatement shall be considered an Event of Default.

4.3 Additional Charges

Tenant shall pay to City any and all charges and other amounts required under this Lease as additional rent (collectively, "Additional Charges"). All such Additional Charges shall be payable to City at the same place and the same manner as the Base Rent and Percentage Rent are payable. City shall have the same remedies for a default in the payment of any Additional Charges as for a default in the payment of Base Rent or Percentage Rent. As used in this Lease, the term "Rent" shall include the Base Rent, Percentage Rent, Additional Charges and any other amounts Tenant is obligated to pay hereunder, whether or not any such amounts are specifically characterized as rent.

4.4 Late Charges

If Tenant fails to pay any Rent or any portion of Rent within five (5) days following the due date therefor, City shall have the right to require Tenant to pay a late payment charge for such late payment equal to six percent (6%) of the unpaid amount in each instance. The late payment charge has been agreed upon by City and Tenant, after negotiation, as a reasonable estimate of the additional administrative costs and detriment that City will incur as a result of any such failure by Tenant, the actual costs thereof being extremely difficult if not impossible to determine. The late payment charge constitutes liquidated damages to compensate City for its damages resulting from such failure to pay and shall be paid to City together with such unpaid amount.

4.5 Default Interest

If any Rent or any portion of Rent is not paid within five (5) days following the due date therefor, City shall have the right to require Tenant to pay interest on such amount from the due date until paid at the rate of ten percent (10%) per year or, if a higher rate is legally permissible,

at the highest rate an individual is permitted to charge under law (the "Interest Rate"). However, interest shall not be payable on late charges incurred by Tenant nor on any amounts on which late charges are paid by Tenant to the extent this interest would cause the total interest to be in excess of that which an individual is lawfully permitted to charge. Payment of interest shall not excuse or cure any default by Tenant.

4.5 Payments

All sums payable by Tenant to City hereunder shall be paid in cash or by good (cashier's or certified) check to the City and County of San Francisco in care of the Director of Property at the primary address for City specified in the Basic Lease Information, or such other place as City may designate in writing. If Tenant pays by check and such check is not honored, then City may require Tenant to make all future payments in cash or by cashier's check.

5. USE

5.1 Approved Use

Between the Effective Date and the Rent Commencement Date, Tenant shall only use the Premises to perform the Tenant Improvements and to install Tenant's Personal Property (as defined in Section 7.3 below) and for no other purpose unless approved in writing by the City's Director of Property in consultation with the Director of OEWD. Following the Rent Commencement Date, Tenant shall use and continuously occupy the Premises solely for the operation of a restaurant, bar, and/or food market hall and any other purpose approved in advance and in writing by the City's Director of Property in consultation with the Director of OEWD, all of which shall be in compliance with all applicable laws.

5.2 No Unlawful Uses, Nuisances or Waste

Without limiting the foregoing, Tenant shall not use, occupy or permit the use or occupancy of any of the Premises in any unlawful manner or for any illegal purpose, or permit any offensive, noisy or hazardous use or any waste on or about the Premises. Tenant shall take all precautions to eliminate any nuisances or hazards relating to its activities on or about the Premises. Tenant shall not conduct any business, place any sales display, or advertise in any manner in areas outside the Building except identification signs in a location and size and design approved by City in its sole discretion.

5.3 Prevailing Wages for Certain Uses

Tenant shall pay, and shall require its subtenants, and contractors and subcontractors (regardless of tier) to pay, prevailing wages, including fringe benefits or the matching equivalents thereof, to persons performing services for the following activity on the Premises as set forth in and to the extent required by San Francisco Administrative Code Chapter 21C: a Public Off-Street Parking Lot, Garage or Automobile Storage Facility (as defined in Section 21C.3), a Show (as defined in Section 21C.4), a Trade Show and Special Event (as defined in Section 21C.8), and Broadcast Services (as defined in Section 21C.9), Commercial Vehicles, Loading and Unloading for Shows and Special Events (as defined in Section 21C.10), and Security Guard Services for Events (as defined in Section 21C.11).

If Tenant, or its subtenants, contractors, and subcontractors fail to comply with the applicable obligations in San Francisco Administrative Code Chapter 21C, City shall have all available remedies set forth in Chapter 21C and the remedies set forth in this Lease. City may inspect and/or audit any workplace, job site, books and records pertaining to the applicable services and may interview any individual who provides, or has provided, such services. Tenant shall provide to City (and require any subtenant, contractor or subcontractor who maintains such

records to provide to City) immediate access to all workers' time sheets, payroll records, and paychecks for inspection on request to the extent they relate to such services.

- The types of covered services related to a Show includes individuals engaged in theatrical or technical services, including rigging, sound, projection, theatrical lighting, videos, computers, draping, carpentry, special effects, and motion picture services.
- The types of covered services related to a Special Event includes individuals engaged in on-site installation, set-up, assembly, and dismantling of temporary exhibits, displays, booths, modular systems, signage, drapery, specialty furniture, floor coverings, and decorative materials in connection with trade shows, conventions, expositions, and other special events on City property.
- The types of covered services related to Broadcast Services includes individuals engaged in the electronic capture and/or live transmission of on-site video, digital, and/or video content for commercial purposes through the use of a remote production or satellite trust on-site, including any technical director, video controller, assistant director, and stage manager, and individuals engaged in audio, camera, capture and playback, graphics and utility functions.

6. TENANT IMPROVEMENTS

6.1 Tenant Improvement Work

City hereby approves the initial plans and specifications dated May 29, 2018, prepared by Perkins + Will, Tenant's architect, copies of which are attached hereto as Exhibit E, for the construction and installation of the tenant improvements at the Premises (such work is referred to as the "Tenant Improvement Work" or "Tenant Improvements" and such plans and specifications are referred to as the "Plans"). Tenant shall cause the Tenant Improvement Work to be performed in accordance with the approved Plans, the standards contained in Section 7.1 (Tenant's Alterations) below, and the requirements of the Work Letter. Tenant shall be responsible, at no cost to City, for performing the Tenant Improvement Work and for obtaining all permits and licenses required in connection with the Tenant Improvements. No Tenant Improvement Work shall commence in the Premises and Tenant shall not make any material change to the Plans or consent to any change order during the course of construction without first obtaining City's written approval.

Tenant shall ensure that all work is performed in a manner that does not obstruct access to or through the Building or interfere with the Fire and Alarm System Maintenance or the Permitted Uses. Upon completion of the Tenant Improvements, Tenant shall furnish City with a copy of the final as-built plans and specifications. No approval by City or any of its Agents of the Plans, any changes thereto or of any Alterations for purposes of this Lease shall be deemed to constitute approval of any federal, state or local regulatory authority with jurisdiction over the Premises or Tenant's use hereunder (including City acting in its regulatory capacity), and nothing herein shall limit Tenant's obligation to obtain all such regulatory approvals at no cost to the City. If any Tenant Improvements would be visible from the exterior of the Building, Tenant, shall obtain the prior written approval of City's Arts Commission to the extent the Arts Commission has jurisdiction over the design of such proposed component under City's Charter Section 5.103.

6.2 Local Hiring Requirements

Any undefined, initially-capitalized term used in this Section shall have the meaning given to such term in San Francisco Administrative Code Section 23.62 (the "Local Hiring Requirements"). Tenant Improvements and Alterations (as defined in Section 7.1) are subject to

the Local Hiring Requirements unless the cost for such work is (i) estimated to be less than \$750,000 per building permit or (ii) meets any of the other exemptions in the Local Hiring Requirements. Tenant agrees that it shall comply with the Local Hiring Requirements to the extent applicable. Before starting any Tenant Improvement Work or any Alteration, Tenant shall contact OEWD to verify if the Local Hiring Requirements apply to the work (i.e., whether the work is a "Covered Project").

Tenant shall include, and shall require its subtenants to include, a requirement to comply with the Local Hiring Requirements in any contract for a Covered Project with specific reference to San Francisco Administrative Code Section 23.62. Each such contract shall name the City and County of San Francisco as a third party beneficiary for the limited purpose of enforcing the Local Hiring Requirements, including the right to file charges and seek penalties. Tenant shall cooperate, and require its subtenants to cooperate, with the City in any action or proceeding against a contractor or subcontractor that fails to comply with the Local Hiring Requirements when required. Tenant's failure to comply with its obligations under this Section shall constitute a material breach of this Lease. A contractor's or subcontractor's failure to comply with this Section will enable the City to seek the remedies specified in San Francisco Administrative Code Section 23.62 against the breaching party.

6.3 Prevailing Wages and Working Conditions

Any undefined, initially-capitalized term used in this Section shall have the meaning given to such term in San Francisco Administrative Code Section 23.61. Tenant shall require its Contractors and Subcontractors performing (i) labor in connection with a "public work" as defined under California Labor Code Section 1720 *et seq.* (which includes certain construction, alteration, maintenance, demolition, installation, repair, carpet laying, or refuse hauling work if paid for in whole or part out of public funds) or (ii) Covered Construction, at the Premises to (1) pay workers performing such work not less than the Prevailing Rate of Wages, (2) provide the same hours, working conditions and benefits as in each case are provided for similar work performed in San Francisco County, and (3) employ Apprentices in accordance with San Francisco Administrative Code Section 23.61 (collectively, "Prevailing Wage Requirements"). Tenant agrees to cooperate with the City in any action or proceeding against a Contractor or Subcontractor that fails to comply with the Prevailing Wage Requirements.

Tenant shall include, and shall require its subtenants, and Contractors and Subcontractors (regardless of tier), to include the Prevailing Wage Requirements and the agreement to cooperate in City enforcement actions in any Construction Contract with specific reference to San Francisco Administrative Code Section 23.61. Each such Construction Contract shall name the City and County of San Francisco, affected workers, and employee organizations formally representing affected workers as third party beneficiaries for the limited purpose of enforcing the Prevailing Wage Requirements, including the right to file charges and seek penalties against any Contractor or Subcontractor in accordance with San Francisco Administrative Code Section 23.61. Tenant's failure to comply with its obligations under this Section shall constitute a material breach of this Lease. A Contractor's or Subcontractor's failure to comply with this Section will enable the City to seek the remedies specified in San Francisco Administrative Code Section 23.61 against the breaching party. For the current Prevailing Rate of Wages, see www.sfgov.org/olse or call the City's Office of Labor Standards Enforcement at 415-554-6235.

Tenant shall also pay, and shall require its subtenants, and Contractors and Subcontractors (regardless of tier) to pay, the Prevailing Rate of Wage for the following activities on the Premises as set forth in and to the extent required by San Francisco Administrative Code Chapter 21C: a Public Off-Street Parking Lot, Garage or Automobile Storage Facility (as defined in Section 21C.3), a Show (as defined in Section 21C.4), a Special Event (as defined in Section 21C.8), Broadcast Services (as defined in Section 21C.9), Commercial Vehicles, Loading and Unloading for Shows and Special Events (as defined in Section 21C.10), and Security Guard Services for Events (as defined in Section 21C.11).

6.4 Construction Insurance; Performance and Payment Bond

Prior to commencing the Tenant Improvement Work, Tenant shall comply with the insurance requirements in Section 19.1(b) below and, at least five (5) business days prior to commencing any of the Tenant Improvement Work, Tenant shall provide, at its sole cost and expense, to City (i) a corporate surety payment bond and a performance bond substantially in the form attached hereto as Exhibit F and obtained by each of Tenant's contractors performing any of the Tenant Improvement Work, or (ii) a financial guarantee, in a form approved by City in its sole discretion, from a third party with liquid assets in an amount of no less than one hundred twenty-five percent (125%) of the cost of the Tenant Improvement Work. Each bond shall be in an amount equal to one hundred percent (100%) of the estimated costs of the Tenant Improvement Work. Each performance bond shall guarantee the contractor's faithful performance of its contract(s) with Tenant. Each payment bond shall guarantee the contractor's payment of labor, materials, supplies and equipment used in the performance of its contract(s) with Tenant. The bonds are intended to help protect City against any liability for mechanics' and materialmen's liens, stop notices and to ensure completion of the work. Corporate sureties issuing these bonds shall be legally authorized to engage in the business of furnishing surety bonds in the State of California. All sureties shall have a current A.M. Best Rating of not less than A-, VIII. Each corporate surety bond shall obligate the surety to Tenant and the City and County of San Francisco as co-obligees.

6.5 Delay in Completion of Tenant Improvement Work

If City's Department of Building Inspection does not issue a temporary certificate of completion for the Tenant Improvements on or before (i) the eighteen (18) month anniversary of the Effective Date for any reason under Tenant's reasonable control, or (ii) the twenty-fourth (24th) month anniversary of the Effective Date for any reason, City shall have the right, at its sole election, to terminate this Lease by delivering written notice of such termination to Tenant at any time prior to such issuance of such temporary certificate of completion. If City timely delivers such termination notice to Tenant, the effective date of termination shall be the date specified in such notice.

7. ALTERATIONS

7.1 Tenant's Alterations

(a) General

Tenant shall not make or permit any alterations to the Building or to the heating, ventilating, air conditioning, plumbing, electrical, fire protection, life safety, security and other mechanical, electrical, communications systems of the Building ("Building Systems"), and shall not make or permit any alterations, installations, additions or improvements, structural or otherwise (collectively, with the Tenant Improvements, "Alterations"), in, to or about the Premises, without City's prior written consent in each instance. All Alterations shall be done at Tenant's expense in accordance with plans and specifications approved by City, only by duly licensed and bonded contractors or mechanics approved by City, and subject to any conditions that City may reasonably impose, including, but not limited to, requiring a performance bond with respect to the performance of such Alterations, requiring such contractors or mechanics to indemnify City with respect to Claims (as defined in Section 18.2) with respect to the Premises or such Alteration, and/or requiring the insurance described in Section 19.1(b). If any Alterations would be visible from the exterior of the Building, Tenant, shall obtain the prior written approval of City's Arts Commission to the extent the Arts Commission has jurisdiction over the design of such proposed alterations under City's Charter Section 5.103.

(b) Asbestos

Without limiting Section 26.2 (No Hazardous Materials) below, in the event that asbestos-containing materials ("ACM") are determined to exist in or about the Premises, Tenant shall ensure that all Alterations and any asbestos related work, as defined in California Health & Safety Code Section 25914.1(b), is performed in compliance with all laws relating to asbestos, including but not limited to California Occupational Safety and Health (OSHA) regulations found in Title 8 of the California Code of Regulations, Sections 1502 and 1529. Additionally, Tenant shall distribute notifications to all employees and contractors as required pursuant to California Health & Safety Code Section 25915 et seq. informing them of the existence of ACM and that moving, drilling, boring, or otherwise disturbing ACM may present a health risk and should not be attempted by an unqualified employee. No Alterations affecting ACM-containing areas or any asbestos related work shall be performed without City's prior written consent in each instance.

(c) Prevailing Wage and Local Hiring Requirements

Tenant and its subtenants shall comply with the applicable requirements of Section 6.2 (Local Hiring Requirements) and Section 6.3 (Prevailing Wages and Working Conditions) above in the performance of any Alterations.

(d) Tenant's Improvements or Alterations that Disturb or Remove Lead-Based Paint

Tenant, on behalf of itself and its Agents or Invitees, shall comply with all requirements of the San Francisco Building Code, Section 3407, and all other applicable present or future federal, state, local and administrative laws, rules, regulations, orders and other governmental requirements, the requirements of any board of fire underwriters or other similar body, any directive or occupancy certificate issued pursuant to any law by any public officer or officers acting in their regulatory capacity (collectively, "Laws"), including, without limitation, the California and United States Occupational Health and Safety Acts and their implementing regulations, when the work of improvement or alteration disturbs or removes exterior lead-based or "presumed" lead-based paint (as defined below). Tenant and its Agents or Invitees shall give to City three (3) business days' prior written notice of any disturbance or removal of exterior lead-based or presumed lead-based paint. Further, Tenant and its Agents or Invitees, when disturbing or removing exterior lead-based or presumed lead-based paint, shall not use or cause to be used any of the following methods: (a) acetylene or propane burning and torching; (b) scraping, sanding or grinding without containment barriers or a High Efficiency Particulate Air filter ("HEPA") local vacuum exhaust tool; (c) hydroblasting or high-pressure wash without containment barriers; (d) abrasive blasting or sandblasting without containment barriers or a HEPA vacuum exhaust tool; and (e) heat guns operating above 1,100 degrees Fahrenheit. Paint on the exterior of buildings built before December 31, 1978, is presumed to be lead-based paint unless lead-based paint testing, as defined in Section 3407 of the San Francisco Building Code, demonstrates an absence of lead-based paint on the exterior surfaces of such buildings. Under this Section, lead-based paint is "disturbed or removed" if the work of improvement or alteration involves any action that creates friction, pressure, heat or a chemical reaction upon any lead-based or presumed lead-based paint on an exterior surface so as to abrade, loosen, penetrate, cut through or eliminate paint from that surface. Notice to City under this Lease shall not constitute notice to the City's Department of Building Inspection required under Section 3407 of the San Francisco Building Code.

(e) Design Principles

Tenant shall ensure the Tenant Improvement Work and all Alterations result in a creative and adaptive reuse of an existing space and shall design with Crime Prevention Through

Environmental Design (CPTED) principles in mind. Whenever possible, Tenant's design decisions for the Tenant Improvement Work and any Alterations shall reflect those principles.

7.2 Title to Improvements

Except for Tenant's Personal Property or as may be specifically provided to the contrary in the approved Plans, all appurtenances, fixtures, improvements, equipment, additions, and other property attached or affixed to or installed in the Premises during the Term, including, without limitation, the Tenant Improvements and any Alterations, shall be and remain City's property. Tenant may not remove any such property at any time during or after the Term unless City so requests as further provided in Section 24 (Surrender of Premises) below.

7.3 Tenant's Personal Property

All furniture, trade fixtures, office equipment and articles of movable personal property installed in the Premises by or for the account of Tenant, without expense to City, and that can be removed without structural or other damage to the Premises (collectively, "Tenant's Personal Property") shall be and remain Tenant's property. Tenant may remove Tenant's Personal Property at any time during the Term, subject to the provisions of Section 24 (Surrender of Premises) below. Tenant shall pay any taxes or other impositions levied or assessed upon Tenant's Personal Property, at least ten (10) days prior to delinquency, and shall deliver satisfactory evidence of such payment to City upon request.

7.4 City's Alterations of the Building and Building Systems

City reserves the right at any time to make alterations, additions, repairs, deletions or improvements to any part of the Building or the Building Systems, provided that any such alterations or additions shall not materially adversely affect the functional utilization of the Premises for the uses permitted hereunder.

8. REPAIRS AND MAINTENANCE

8.1 City's Repairs

Except for providing the Fire and Alarm System Maintenance (as defined in Section 10.1), City shall have no obligation to repair and maintain any portion of the Premises, including, but not limited to, the structural or non-structural portions of the Building, any Building Systems and the sidewalks and curbs at the Premises, except to the extent damaged by any act or omission of Landlord or its Agents (as defined in Section 27.5 (Parties and Their Agents; Approvals) below) at the Premises or under this Lease. For the purpose of making any such repairs of damage caused by the act or omission of Landlord or its Agents, City may use structures in the Premises where reasonably required by the character of the work to be performed, provided that such work shall not unreasonably interfere with Tenant's business. Tenant waives any claim for damages for any injury or inconvenience to or interference with Tenant's business, any loss of occupancy or quiet enjoyment of the Premises or any other loss occasioned thereby.

8.2 Tenant's Repairs

Tenant shall maintain, at no expense to City, the Premises (including, without limitation, the floors, roof, walls, exterior, interior, plumbing, electrical wiring, fixtures, and equipment) in good repair and working order and in a clean, secure, safe and sanitary condition. Tenant shall promptly make all repairs and replacements: (a) at no cost to the City, (b) by licensed contractors or qualified mechanics approved by City, (c) so that the same shall be at least equal in quality, value and utility to the original work or installation, (d) in a manner and using equipment and materials that will not interfere with or impair the operations, use or occupation

of the Building or the Building Systems, and (e) in accordance with any applicable Building Rules and Regulations (as defined in Section 22 (Rules and Regulations)) and all applicable laws, rules and regulations. Notwithstanding the foregoing, Tenant shall not be required to correct any construction defects in the Building or the Premises in existence as of the Effective Date (an "Existing Defect"). If there is an Existing Defect that materially interferes with the Permitted Uses or threatens public health or safety, Tenant and City shall each have the right to terminate this Lease by delivering no less than thirty (30) days' written notice of such termination to the other party. Tenant hereby waives all rights to make repairs at City's expense under Sections 1941 and 1942 of the California Civil Code or under any similar law, statute or ordinance now or hereafter in effect.

9. LIENS AND ENCUMBRANCES

9.1 Liens

Tenant shall keep the Premises free from any liens arising out of any work performed, material furnished or obligations incurred by or for Tenant. In the event Tenant does not, within five (5) days following the imposition of any such lien, cause the lien to be released or record by payment or posting of a proper bond, City shall have, in addition to all other remedies, the right, but not the obligation, to cause the lien to be released by such means as it shall deem proper, including, but not limited to, payment of the claim giving rise to such lien. All such sums paid by City and all expenses incurred by it in connection therewith (including, without limitation, reasonable attorneys' fees) shall be payable to City by Tenant upon demand. City shall have the right to post on the Premises any notices that City may deem proper for the protection of City, the Premises, and the Building, from mechanics' and material supplier's liens. Tenant shall give to City at least fifteen (15) days' prior written notice of commencement of any Alteration, repair or construction on the Premises. Tenant agrees to indemnify, defend and hold City and its Agents harmless from and against any claims for mechanic's, material supplier's or other liens in connection with any Alterations, repairs or construction on the Premises, or materials furnished or obligations incurred by or for Tenant.

9.2 Encumbrances

Tenant shall not create, permit or suffer any liens or encumbrances affecting any portion of the Premises or City's interest therein or under this Lease.

10. UTILITIES AND SERVICES

10.1 Utilities and Services

City shall provide (i) the utilities described in the attached Exhibit G (the "Standard Utilities") to the Building, subject to the terms and conditions contained therein, and (ii) the basic Building fire sprinkler system and alarm system maintenance (the "Fire and Alarm System Maintenance") described in that certain Fire Alarm and Life Safety System Inspection & Testing Services contract between City and Pacific Auxiliary Fire Alarm Company, dated as of September 2, 2016 (together, the "Maintenance Agreements"), subject to the terms and conditions contained therein. Tenant acknowledges it has received a copy of the Maintenance Agreements. Tenant shall pay City, as additional rent, an amount equal to such the City's cost to provide the Standard Utilities and the Fire and Alarm System Maintenance within thirty (30) days of receiving City's invoice therefor. Any City failure to bill Tenant for such costs shall not impair City's right to bill Tenant for such costs at a later date.

Notwithstanding anything to the contrary in the foregoing paragraph, if Tenant reasonably determines the Building fire sprinkler system and/or alarm system must be improved to comply with any applicable laws or meet reasonable and applicable commercial standards, City shall have no obligation to provide Fire and Alarm System Maintenance to such system

during the period it is being improved. Tenant shall deliver no less than thirty (30) days' prior written notice to City of any removal or improvement to the Building fire sprinkler system and Tenant shall coordinate with City's Fire and Alarm System Maintenance contractors as may be required in the Maintenance Agreements.

Tenant shall be responsible for furnishing, at Tenant's sole cost, any utilities or services other than or in excess of the Standard Utilities and Fire and Alarm System Maintenance that Tenant may need or desire for its use of the Premises, and for performing all necessary repairs or replacements to the Building fire sprinkler system and alarm system.

10.2 Water and Energy Conservation; Mandatory or Voluntary Restrictions

In the event any law, ordinance, code or governmental or regulatory guideline imposes mandatory or voluntary controls on City or the Premises or any part thereof, relating to the use or conservation of energy, water, gas, light or electricity or the reduction of automobile or other emissions, or the provision of any other utility or service provided with respect to this Lease, or in the event City is required or elects to make alterations to any part of the Building in order to comply with such mandatory or voluntary controls or guidelines, such compliance and the making of such alterations shall in no event entitle Tenant to any damages, relieve Tenant of the obligation to pay the full Base Rent, Percentage Rent, and Additional Charges reserved hereunder or to perform each of its other covenants hereunder or constitute or be construed as a constructive or other eviction of Tenant. City shall have the right at any time to install a water meter in the Premises or otherwise to measure the amount of water consumed on the Premises, and the cost of such meter or other corrective measures and the installation and maintenance thereof shall be paid for by Tenant.

10.3 Excess Use

Tenant shall not: (a) connect or use any apparatus, device or equipment that will impair the proper functioning or capacity of the Building Systems; or (b) connect any apparatus, device or equipment through electrical outlets except in the manner for which such outlets are designed and without the use of any device intended to increase the plug capacity of any electrical outlet; or (c) maintain at any time an electrical demand load in excess of any amount specified therefor in the Rules and Regulations. If at any time during the Term City has reason to believe that Tenant may be using any utility in excess of the amount therefor allowed to the Premises pursuant to the Standard Utilities, City shall have the right to install a separate meter in the Premises or to take other appropriate steps to measure the amount of utility or service used in the Premises, and the cost of such meter and all corrective measures, and the installation and maintenance thereof, shall be paid for by Tenant.

10.4 Floor Load

Without City's prior written consent, which City may give or refuse in its sole discretion, Tenant shall not place or install in the Building any equipment that weighs in excess of the normal load-bearing capacity of the floors of the Building. If City consents to the placement or installation of any such machine or equipment in the Building, Tenant, at no cost to the City, shall reinforce the floor of the Building, pursuant to plans and specifications approved by City and otherwise in compliance with Section 7.1 (Tenant's Alterations), to the extent necessary to assure that no damage to the Building or weakening of any structural supports will be occasioned thereby.

10.5 Interruption of Services

City's obligation to provide the Standard Utilities and Fire and Alarm System Maintenance for the Premises are subject to the Rules and Regulations of the Building, applicable Legal Requirements (as defined below) (including the rules or actions of the public

utility company furnishing the utility or service), and shutdowns for maintenance and repairs, for security purposes, or due to strikes, lockouts, labor disputes, fire or other casualty, acts of God, or other causes beyond the control of City. In the event of an interruption in, or failure or inability to provide any service or utility for the Premises for any reason, such interruption, failure or inability shall not constitute an eviction of Tenant, constructive or otherwise, or impose upon City any liability whatsoever, including, but not limited to, liability for consequential damages or loss of business by Tenant; provided, however, that if such interruption, failure or inability impairs Tenant's ability to carry on its business in the Premises for a period of five (5) or more consecutive business days, then Tenant shall have the right, as Tenant's sole remedy, to abate the Rent based on the extent such interruption, failure or inability impairs Tenant's ability to carry on its business in the Premises. Tenant hereby waives the provisions of California Civil Code Section 1932(1) or any other applicable existing or future Legal Requirement permitting the termination of this Lease due to such interruption, failure or inability.

11. COMPLIANCE WITH LAWS AND RISK MANAGEMENT REQUIREMENTS

11.1 Compliance with Laws

Tenant shall promptly comply, at no cost to the City, with all present or future laws, ordinance, resolution, regulation, requirement, proclamation, order or decree of any municipal, county, state or federal government or other governmental or regulatory authority relating to the Premises or the use or occupancy thereof (the "Legal Requirements") and with any and all recorded covenants, conditions and restrictions affecting the Premises or any portion thereof, whether in effect at the time of the execution of this Lease or adopted or recorded at any time thereafter and whether or not within the present contemplation of the parties. Tenant further understands and agrees that it is Tenant's obligation, at no cost to the City, to cause the Premises and Tenant's uses thereof to be conducted in compliance with the Americans with Disabilities Act, 42 U.S.C. Section 12101 et seq. and any other applicable disability access laws. Tenant shall not be required to make any structural Alterations or Alterations to the Building Systems in order to comply with such laws unless such Alterations shall be occasioned, in whole or in part, directly or indirectly, by the Tenant Improvements or any other Alterations, Tenant's use of the Premises, or any act or omission of Tenant, its Agents or Invitees. Any Alteration made by or on behalf of Tenant pursuant to the provisions of this Section shall comply with the provisions of Section 8.2 (Tenant's Repairs) above. The parties acknowledge and agree that Tenant's obligation to comply with all Legal Requirements as provided herein is a material part of the bargained for consideration under this Lease. Tenant's obligation under this Section shall include, when applicable and without limitation, the responsibility of Tenant to make substantial or structural repairs and Alterations to the Premises (including any of the Tenant Improvements or any of Tenant's Alterations), regardless of, among other factors, the relationship of the cost of curative action to the Rent under this Lease, the length of the then remaining Term hereof, the relative benefit of the repairs to Tenant or City, the degree to which the curative action may interfere with Tenant's use or enjoyment of the Premises, the likelihood that the parties contemplated the particular Legal Requirement involved, and whether the Legal Requirement involved is related to Tenant's particular use of the Premises.

11.2 Regulatory Approvals

(a) Responsible Party

Tenant understands and agrees that Tenant's use of the Premises and construction of the Tenant Improvements permitted hereunder may require authorizations, approvals or permits from governmental regulatory agencies with jurisdiction over the Premises, including, without limitation, City agencies. Tenant shall be solely responsible for obtaining any and all such regulatory approvals. Tenant shall not seek any regulatory approval without first obtaining the written consent of City under this Lease. Tenant shall bear all costs associated with applying for and obtaining any necessary or appropriate regulatory approval and shall be solely

responsible for satisfying any and all conditions imposed by regulatory agencies as part of a regulatory approval; provided, however, any such condition that could affect use or occupancy of the Premises or City's interest therein must first be approved by City in its sole discretion. Any fines or penalties levied as a result of Tenant's failure to comply with the terms and conditions of any regulatory approval shall be immediately paid and discharged by Tenant, and City shall have no liability, monetary or otherwise, for any such fines or penalties. Tenant shall Indemnify City and the other Indemnified Parties (as such terms are defined in Section 18.2 (Tenant's Indemnity) below) hereunder against all Claims arising in connection with Tenant's failure to obtain or failure by Tenant, its Agents or Invitees to comply with the terms and conditions of any regulatory approval.

(b) City Acting as Owner of Real Property

Tenant further understands and agrees that City is entering into this Lease in its capacity as a property owner with a proprietary interest in the Premises and not as a regulatory agency with police powers. Nothing in this Lease shall limit in any way Tenant's obligation to obtain any required approvals from City officials, departments, boards or commissions having jurisdiction over the Premises. By entering into this Lease, City is in no way modifying or limiting Tenant's obligation to cause the Premises to be used and occupied in accordance with all applicable laws, as provided further above.

11.3 Compliance with City's Risk Management Requirements

Tenant shall not do anything, or permit anything to be done, in or about the Premises which would be prohibited by or increase rates under a standard form fire insurance policy or subject City to potential premises liability. Tenant shall faithfully observe, at no cost to the City, any and all requirements of City's Risk Manager with respect to Tenant's use and occupancy of the Premises, so long as such requirements do not unreasonably interfere with Tenant's use of the Premises or are otherwise connected with standard prudent commercial practices of other landlords.

12. SUBORDINATION

This Lease is and shall be subordinate to the Access Easements and any other easements, ground lease, facilities lease or other underlying lease and the lien of any mortgage or deed of trust and all renewals, modifications, consolidations, replacements and extensions of any of the foregoing, that may now exist or hereafter be executed by City affecting the Premises, or any part thereof or City's interest therein (each, a "Priority Document"), without the necessity of executing any instrument to effectuate such subordination if such Priority Document is executed before the Effective Date. Tenant shall subordinate this Lease to any Priority Document executed after the Effective Date if Tenant receives a commercially reasonable non-disturbance agreement with respect to such Priority Document. Upon City's request, Tenant, or Tenant's successor-in-interest, shall execute and deliver any and all instruments desired by City evidencing the subordination of this Lease to any Priority Document pursuant to this Section in the manner requested by City. Notwithstanding the foregoing, City or the holder of a Priority Document shall, in its respective discretion, have the right to subordinate any such interests to this Lease. If any ground lease or underlying lease terminates for any reason or any mortgage or deed of trust is foreclosed or a conveyance in lieu of foreclosure is made for any reason, Tenant shall attorn to the successor-in-interest to City, at the option of such successor-in-interest. The provisions of this Section shall be self-operative and no further instrument shall be required except as otherwise expressly set forth in this Section. Tenant agrees, however, to execute and deliver, upon demand by City and in the form requested by City, any additional documents evidencing the priority or subordination of this Lease (subject to Tenant's receipt of a commercially reasonable non-disturbance agreement with respect to the subordination to any Priority Documents executed after the Effective Date).

13. INABILITY TO PERFORM

No actual or constructive eviction, in whole or in part, shall entitle Tenant to any abatement or diminution of Rent or relieve Tenant from any of its obligations under this Lease. If City is unable to perform or is delayed in performing any of City's obligations under this Lease, by reason of acts of God, accidents, breakage, repairs, strikes, lockouts, other labor disputes, protests, riots, demonstrations, inability to obtain utilities or materials or by any other reason beyond City's reasonable control, no such inability or delay shall constitute an eviction under this Lease, or impose any liability upon City or its Agents by reason of inconvenience, annoyance, interruption, injury or loss to or interference with Tenant's business or use and occupancy or quiet enjoyment of the Premises or any loss or damage occasioned thereby. Tenant hereby waives and releases any right to terminate this Lease under Section 1932, subdivision 1 of the California Civil Code or any similar law, statute or ordinance now or hereafter in effect.

14. DAMAGE AND DESTRUCTION

14.1 Damage and Destruction

If the Premises or the Building is damaged by fire or other casualty, then neither party shall have the obligation to repair the same (or any damage to Tenant's Personal Property, any paneling, decorations, railings, floor coverings, any Tenant Improvements, or any Alterations) and either party shall have the right to terminate this Lease by delivering written notice of such termination to the other party within thirty (30) days of the date of such damage. If neither party elects to terminate this Lease by reason of such damage, this Lease shall remain in full force and effect except that Tenant shall be entitled to a proportionate reduction of Base Rent based upon the extent to which such damage materially interferes with Tenant's use or occupancy of the Premises.

14.2 Waiver

City and Tenant intend that the provisions of this Section govern fully in the event of any damage or destruction and accordingly, City and Tenant each hereby waives the provisions of Section 1932, subdivision 2, Section 1933, subdivision 4 and Sections 1941 and 1942, of the Civil Code of California or under any similar law, statute or ordinance now or hereafter in effect.

15. EMINENT DOMAIN

15.1 Definitions

(a) "Taking" means a taking or damaging, including severance damage, by eminent domain, inverse condemnation or for any public or quasi-public use under law. A Taking may occur pursuant to the recording of a final order of condemnation, or by voluntary sale or conveyance in lieu of condemnation or in settlement of a condemnation action.

(b) "Date of Taking" means the earlier of (i) the date upon which title to the portion of the Premises taken passes to and vests in the condemnor or (ii) the date on which Tenant is dispossessed.

(c) "Award" means all compensation, sums or anything of value paid, awarded or received for a Taking, whether pursuant to judgment, agreement, settlement or otherwise.

(d) "Improvements Pertaining to the Realty" means machinery or equipment installed for use on the Premises that cannot be removed without a substantial economic loss or without substantial damage to the property on which it is installed, regardless of the method of installation. In determining whether particular property can be removed "without a substantial

economic loss," the value of the machinery or equipment in place and considered as part of the realty should be compared with its value if it were removed and sold.

15.2 General

If during the Term there is any Taking of all or any part of the Premises or any interest in this Lease, the rights and obligations of the parties hereunder shall be determined pursuant to this Section. City and Tenant intend that the provisions hereof govern fully in the event of a Taking and accordingly, the parties each hereby waive any right to terminate this Lease in whole or in part under Sections 1265.110, 1265.120, 1265.130 and 1265.140 of the California Code of Civil Procedure or under any similar law now or hereafter in effect.

15.3 Total Taking; Automatic Termination

If there is a total Taking of the Premises, then this Lease shall terminate as of the Date of Taking.

15.4 Partial Taking; Election to Terminate

(a) If there is a Taking of any portion (but less than all) of the Premises, then this Lease shall terminate in its entirety under either of the following circumstances: (i) if all of the following exist: (A) the partial Taking renders the remaining portion of the Premises untenable or unsuitable for continued use by Tenant, (B) the condition rendering the Premises untenable or unsuitable either is not curable or is curable but City is unwilling or unable to cure such condition, and (C) Tenant elects to terminate; or (ii) if City elects to terminate; provided, however, that this Lease shall not terminate if Tenant agrees to, and does, pay full Rent and Additional Charges, without abatement, and otherwise agrees to, and does, fully perform all of its obligations hereunder.

(b) If there is a partial Taking of a substantial portion of the Building but not the Premises, City shall have the right to terminate this Lease in its entirety.

(c) Either party electing to terminate under the provisions of this Section 15 shall do so by giving the other party written notice to the other party before or within thirty (30) days after the Date of Taking, and thereafter this Lease shall terminate upon the later of the thirtieth (30th) day after such written notice is given or the Date of Taking.

15.5 Termination of Lease; Rent and Award

Upon termination of this Lease in its entirety pursuant to Section 15.3 (Total Taking; Automatic Termination), or pursuant to an election under Section 15.4 (Partial Taking, Election to Terminate) above, then: (a) Tenant's obligation to pay Rent shall continue up until the date of termination and thereafter shall cease, and (b) City shall be entitled to the entire Award in connection therewith (including, but not limited to, any portion of the Award made for the value of the leasehold estate created by this Lease and any Improvements Pertaining to the Realty), and Tenant shall have no claim against City for the value of any unexpired term of this Lease, provided that Tenant may make a separate claim for compensation, and Tenant shall receive any Award made specifically to Tenant, for Tenant's relocation expenses or the interruption of or damage to Tenant's business or damage to movable Tenant's Personal Property.

15.6 Partial Taking; Continuation of Lease

If there is a partial Taking of the Premises under circumstances where this Lease is not terminated in its entirety under Section 15.4 (Partial Taking; Election to Terminate) above, then this Lease shall terminate as to the portion of the Premises so taken, but shall remain in full force and effect as to the portion not taken, and the rights and obligations of the parties shall be as

follows: (a) Base Rent shall be reduced by an amount that is in the same ratio to the Base Rent as the area of the Premises taken bears to the area of the Premises prior to the Date of Taking; provided, however, in no event shall the monthly Base Rent be reduced to less than seventy-five percent (75%) of the monthly Base Rent immediately prior to the Date of Taking, and (b) City shall be entitled to the entire Award in connection therewith (including, but not limited to, any portion of the Award made for the value of the leasehold estate created by this Lease), and Tenant shall have no claim against City for the value of any unexpired term of this Lease, provided that Tenant may make a separate claim for compensation, and Tenant shall receive any Award made specifically to Tenant, for Tenant's relocation expenses or the interruption of or damage to Tenant's business or damage to movable Tenant's Personal Property.

15.7 Temporary Takings

Notwithstanding anything to contrary in this Section, if a Taking occurs with respect to all or any part of the Premises for a limited period of time not in excess of one hundred eighty (180) consecutive days, this Lease shall remain unaffected thereby, and Tenant shall continue to pay Rent and to perform all of the terms, conditions and covenants of this Lease. In the event of such temporary Taking, Tenant shall be entitled to receive that portion of any Award representing compensation for the use or occupancy of the Premises during the Term up to the total Rent owing by Tenant for the period of the Taking, and City shall be entitled to receive the balance of any Award.

16. ASSIGNMENT AND SUBLETTING

16.1 Restriction on Assignment and Subletting

Except as otherwise set forth in the following paragraph, Tenant shall not directly or indirectly (including, without limitation, by merger, acquisition or other transfer of any controlling interest in Tenant), voluntarily or by operation of law, sell, assign, encumber, pledge or otherwise transfer any part of its interest in or rights with respect to the Premises or its leasehold estate hereunder (collectively, an "Assignment"), or permit or license any portion of the Premises to be used or occupied by anyone other than itself, or sublet any portion of the Premises (collectively, "Sublease"), without City's prior written consent in each instance, as provided hereinbelow.

Tenant shall have the right to enter into an Assignment or Sublease without obtaining the consent of City to any Tenant's Affiliate (as defined below), provided Tenant gives City written notice of its intent thereof at least fifteen (15) business days before the proposed effective date of such transfer. In addition, City acknowledges that Tenant's intended use of the Premises is as a market hall with multiple small vendors that cultivates low-income food entrepreneurs. Accordingly, Tenant shall have the right to Sublease any or all portions of the Premises to vendors (each, a "Vendor") without obtaining the consent of City; provided, however, that Tenant shall use commercially reasonable efforts to select Vendors that are low-income, local businesses, and shall charge commercially reasonable rates to Vendors that are reasonably capable of paying them.

As used in this Section, the term "Tenant's Affiliate" shall mean, any of the following: (a) any person or entity owning, directly or indirectly, fifty percent (50%) or more of the ownership interests of Tenant (an "Owning Person"), (b) any entity, fifty percent (50%) or more of the ownership interests of which are owned, directly or indirectly, by any Owning Person, (c) any entity, fifty percent (50%) or more of the ownership interests of which are owned, directly or indirectly, by Tenant.

16.2 Notice of Proposed Transfer

If Tenant desires to enter into an Assignment or a Sublease that requires City's consent pursuant to Section 16.1 above, it shall give written notice (a "Notice of Proposed Transfer") to City of its intention to do so. The Notice of Proposed Transfer shall identify the proposed transferee and state the terms and conditions of the proposed Assignment or Sublease. Tenant shall deliver to City with its request for City's consent the proposed Assignment or Sublease and current financial statements of the proposed transferee, prepared by an independent certified public accountant, and promptly upon City's request for same, any additional documents or information reasonably related to the proposed transaction or transferee.

16.3 City's Response

Within twenty (20) business days after City's receipt of the Notice of Proposed Transfer (the "Response Period"), City may elect, by written notice to Tenant, to: (a) sublease the portion of the Premises specified in the Notice of Proposed Transfer on the terms and conditions set forth in such notice, except as otherwise provided in Section 16.4 (Sublease or Recapture Space); or (b) terminate this Lease as to the portion (including all) of the Premises that is specified in the Notice of Proposed Transfer, with a proportionate reduction in Base Rent (a "Recapture").

If City declines to exercise either of its options provided above, then Tenant shall have ninety (90) days following the earlier of (i) City's notice that it will not elect either such option or (ii) the expiration of the Response Period, to enter into such Assignment or Sublease, subject to City's prior written approval of the proposed assignee or subtenant (each, a "Transferee") and the terms and conditions of the proposed Sublease or Assignment. However, one hundred percent (100%) of any rent or other consideration realized by Tenant under any such Assignment or Sublease in excess of the Base Rent and Additional Charges payable hereunder (or the amount thereof proportionate to the portion of the Premises subject to such Sublease or Recapture) shall be paid to City, after Tenant has recovered any reasonable brokers' commissions and the reasonable cost of any leasehold improvements that Tenant has incurred in connection with such Sublease or Recapture. Tenant shall provide City with such information regarding the proposed Transferee and the Assignment or Sublease as City may reasonably request. City agrees that it will not unreasonably withhold its approval of any proposed Transferee.

If after City declines to exercise any of the foregoing options Tenant desires to enter into such Assignment or Sublease (A) on terms and conditions materially more favorable to Tenant than those contained in the Notice of Proposed Transfer or (B) with a Transferee that is currently a tenant or other occupant of the Building, then Tenant shall give City a new Notice of Proposed Transfer, which notice shall state the terms and conditions of such Assignment or Sublease and identify the proposed Transferee, and City shall again be entitled to elect one of the options provided in clauses (a) and (b) at any time within twenty (20) business days after City's receipt of such new Notice of Proposed Transfer.

In the event City elects either of the options provided in clauses (a) or (b), City shall be entitled to enter into a lease, sublease or assignment agreement with respect to the Premises (or portion thereof specified in such new Notice of Proposed Transfer) with the proposed Transferee identified in Tenant's notice.

Notwithstanding the foregoing, if any event of default by Tenant is outstanding hereunder at the time of Tenant's Notice of Proposed Transfer (or if any event shall have occurred which with the giving of notice or the passage of time or both would constitute such a default), then City may elect by notice to Tenant to refuse to consent to Tenant's proposed Transfer and pursue any of its right or remedies hereunder or at law or in equity.

16.4 Sublease or Recapture Space

If City elects to Sublease or Recapture from Tenant as described in Section 16.3 (City's Response) the following shall apply:

(a) In the case of a Sublease, (i) City shall have the right to use the portion of the Premises covered by the Notice of Proposed Transfer (the "Sublease Space") for any legal purpose, (ii) the rent payable by City to Tenant shall be the lesser of (A) the amount in the Notice of Proposed Transfer or (B) the Base Rent payable by Tenant under this Lease at the time of the Sublease (or the amount thereof proportionate to the Sublease Space if for less than the entire Premises), (iii) City may make alterations and improvements to the Sublease Space and may remove any such alterations or improvements, in whole or in part, prior to or upon the expiration of the Sublease, provided that City shall repair any damage or injury to the Sublease Space caused by such removal, (iv) City shall have the right to further sublease or assign the Sublease Space to any party, without the consent of Tenant, and (v) Tenant shall pay to City on demand any costs incurred by City in physically separating the Sublease Space (if less than the entire Premises) from the balance of the Premises and in complying with any applicable laws or regulations relating to such separation.

(b) In the case of Recapture, (i) the portion of the Premises subject to the Recapture (the "Recapture Space") shall be deleted from the Premises for all purposes hereunder, and Tenant and City shall be relieved of all their rights and obligations hereunder with respect to the Recapture Space except to the extent the same would survive the termination of this Lease pursuant to the provisions hereof, and (ii) City shall pay any cost incurred in physically separating the Recapture Space (if less than the entire Premises) from the balance of the Premises and in complying with any applicable governmental laws or regulations relating to such separation.

16.5 Effect of Sublease or Assignment

No Sublease or Assignment by Tenant nor any consent by City thereto shall relieve Tenant, or any guarantor, of any obligation to be performed by Tenant under this Lease. Any Sublease or Assignment not in compliance with this Section shall be void and, at City's option, shall constitute a material default by Tenant under this Lease. The acceptance of any Rent or other payments by City from a proposed Transferee shall not constitute consent to such Sublease or Assignment by City or a recognition of any Transferee, or a waiver by City of any failure of Tenant or other transferor to comply with this Section. If there is an Assignment or Sublease, whether in violation of or in compliance with this Section, in the event of default by any Transferee, Tenant's Affiliate, Vendor, or any successor of Tenant, in the performance or observance of any of the terms of this Lease or any Sublease or Assignment agreement, City may proceed directly against Tenant without the necessity of exhausting remedies against such Transferee, Tenant's Affiliate, Vendor, or successor.

16.6 Assumption by Transferee

Each Transferee (other than City), Tenant's Affiliate, and Vendor shall assume all obligations of Tenant under this Lease and shall be liable jointly and severally with Tenant for the payment of the Base Rent, Percentage Rent, and Additional Charges, and for the performance of all the terms, covenants and conditions to be performed on Tenant's part hereunder. No Assignment shall be binding on City unless Tenant or Transferee has delivered to City a counterpart of the Assignment and an instrument in recordable form that contains a covenant of assumption by such Transferee satisfactory in form and substance to City. However, the failure or refusal of such Transferee to execute such instrument of assumption shall not release such Transferee from its liability as set forth above. Tenant shall reimburse City on demand for any reasonable costs that may be incurred by City in connection with any proposed Sublease or Assignment, including, without limitation, the costs of making investigations as to the

acceptability of the proposed Transferee and legal costs incurred in connection with the granting of any requested consent.

16.7 Indemnity for Relocation Benefits

Without limiting Section 16.6 (Assumption by Transferee) above, Tenant shall cause any Transferee, Tenant's Affiliate, and Vendor to expressly waive entitlement to any and all relocation assistance and benefits in connection with this Lease. Tenant shall Indemnify City for any and all Losses arising out of any relocation assistance or benefits payable to any Transferee, Tenant's Affiliate, or Vendor.

17. DEFAULT; REMEDIES

17.1 Events of Default

Any of the following shall constitute an event of default (the "Event of Default") by Tenant hereunder:

(a) a failure to pay Base Rent, Percentage Rent or Additional Charges when due, and such failure continues for three (3) days after the date of written notice by City. However, City shall not be required to provide such notice more than twice during any twelve (12)-month period, and any such failure by Tenant after Tenant has received two (2) such notices in such twelve (12)-month period shall constitute a default by Tenant hereunder without any further action by City or opportunity of Tenant to cure except as may be required by Section 1161 of the California Code of Civil Procedure;

(b) a failure to comply with any other covenant, condition or representation made under this Lease and such failure continues for fifteen (15) days after the date of written notice by City, provided that if such default is not capable of cure within such fifteen (15)-day period, Tenant shall have a reasonable period to complete such cure if Tenant promptly undertakes action to cure such default within such fifteen (15)-day period and thereafter diligently prosecutes the same to completion within sixty (60) days after the receipt of notice of default from City. City shall not be required to provide such notice more than twice in any twelve (12)-month period with respect to any material non-monetary defaults and after the second notice in any calendar year, any subsequent failure by Tenant during such twelve (12)-month period shall constitute an Event of Default hereunder;

(c) a vacation or abandonment of the Premises for a continuous period in excess of five (5) business days; or

(d) an appointment of a receiver to take possession of all or substantially all of the assets of Tenant, or an assignment by Tenant for the benefit of creditors, or any action taken or suffered by Tenant under any insolvency, bankruptcy, reorganization, moratorium or other debtor relief act or statute, whether now existing or hereafter amended or enacted, if any such receiver, assignment or action is not released, discharged, dismissed or vacated within sixty (60) days.

17.2 Remedies

Upon the occurrence of an Event of Default City shall have the following remedies, which shall not be exclusive but shall be cumulative and shall be in addition to any other remedies now or hereafter allowed by law or in equity:

(a) City may terminate Tenant's right to possession of the Premises at any time by written notice to Tenant. Tenant expressly acknowledges that in the absence of such written notice from City, no other act of City, including, but not limited to, its re-entry into the

Premises, its efforts to relet the Premises, its reletting of the Premises for Tenant's account, its storage of Tenant's Personal Property and trade fixtures, its acceptance of keys to the Premises from Tenant, its appointment of a receiver, or its exercise of any other rights and remedies under this Section 17.2 or otherwise at law, shall constitute an acceptance of Tenant's surrender of the Premises or constitute a termination of this Lease or of Tenant's right to possession of the Premises.

Upon such termination in writing of Tenant's right to possession of the Premises, this Lease shall terminate and City shall be entitled to recover damages from Tenant as provided in California Civil Code Section 1951.2 or any other applicable existing or future Legal Requirement providing for recovery of damages for such breach, including but not limited to the following:

- (i) The reasonable cost of recovering the Premises; plus
- (ii) The reasonable cost of removing Tenant's Alterations, trade fixtures and improvements; plus
- (iii) All unpaid rent due or earned hereunder prior to the date of termination, less the proceeds of any reletting or any rental received from subtenants prior to the date of termination applied as provided in Section 17.2(b) below, together with interest at the Interest Rate, on such sums from the date such rent is due and payable until the date of the award of damages; plus
- (iv) The amount by which the rent which would be payable by Tenant hereunder, including Additional Charges under Section 4.3 (Additional Charges) above, as reasonably estimated by City, from the date of termination until the date of the award of damages, exceeds the amount of such rental loss as Tenant proves could have been reasonably avoided, together with interest at the Interest Rate on such sums from the date such rent is due and payable until the date of the award of damages; plus
- (v) The amount by which the rent which would be payable by Tenant hereunder, including Additional Charges under Section 4.3 (Additional Charges) above, as reasonably estimated by City, for the remainder of the Lease Year in which such termination of Tenant's right to possession occurs, after the date of the award of damages exceeds the amount such rental loss as Tenant proves could have been reasonably avoided, discounted at the discount rate published by the Federal Reserve bank of San Francisco for member banks at the time of the award plus one percent (1%); plus
- (vi) Such other amounts in addition to or in lieu of the foregoing as may be permitted from time to time by applicable law, including without limitation any other amount necessary to compensate City for all the detriment proximately caused by Tenant's failure to perform its obligations under this Lease which in the ordinary course of things would be likely to result therefrom.

(b) City has the remedy described in California Civil Code Section 1951.4 (a landlord may continue the lease in effect after the tenant's breach and abandonment and recover rent as it becomes due, if the tenant has the right to sublet and assign subject only to reasonable limitations), and may continue this Lease in full force and effect and may enforce all of its rights and remedies under this Lease, including, but not limited to, the right to recover rent as it becomes due. After the occurrence of an Event of Default, City may enter the Premises without terminating this Lease and sublet all or any part of the Premises for Tenant's account to any person, for such term (which may be a period beyond the remaining term of this Lease), at such rents and on such other terms and conditions as City deems advisable. In the event of any such subletting, rents received by City from such subletting shall be applied (i) first, to the payment of the costs of maintaining, preserving, altering and preparing the Premises for subletting; the other

costs of subletting, including but not limited to brokers' commissions, attorneys' fees and expenses of removal of Tenant's Personal Property, trade fixtures and Alterations; (ii) second, to the payment of rent then due and payable hereunder; (iii) third, to the payment of future rent as the same may become due and payable hereunder; and (iv) fourth, the balance, if any, shall be paid to Tenant upon (but not before) the termination of this Lease. If the rents received by City from such subletting, after application as provided above, are insufficient in any month to pay the rent due and payable hereunder for such month, Tenant shall pay such deficiency to City monthly upon demand. Notwithstanding any such subletting for Tenant's account without termination, City may at any time thereafter, by written notice to Tenant, elect to terminate this Lease by virtue of a previous Event of Default.

During the continuance of an Event of Default, for so long as City does not terminate Tenant's right to possession of the Premises and subject to Section 16 (Assignment and Subletting) and the options granted to City thereunder, City shall not unreasonably withhold its consent to an assignment or sublease of Tenant's interest in the Premises or in this Lease.

(c) During the continuance of an Event of Default, City may enter the Premises without terminating this Lease and remove all Tenant's Personal Property, Alterations and trade fixtures from the Premises and store them at Tenant's risk and expense. If City removes such property from the Premises and stores it at Tenant's risk and expense, and if Tenant fails to pay the cost of such removal and storage after written demand therefor and/or to pay any rent then due, then after the property has been stored for a period of thirty (30) days or more City may sell such property at public or private sale, in the manner and at such times and places as City deems commercially reasonable following reasonable notice to Tenant of the time and place of such sale. The proceeds of any such sale shall be applied first to the payment of the expenses for removal and storage of the property, the preparation for and the conducting of such sale, and for attorneys' fees and other legal expenses incurred by City in connection therewith, and the balance shall be applied as provided in Section 17.2(b) above.

Tenant hereby waives all claims for damages that may be caused by City's reentering and taking possession of the Premises or removing and storing Tenant's Personal Property pursuant to this Section 17.2, and Tenant shall indemnify, defend and hold City harmless from and against any and all Claims resulting from any such act. No reentry by City shall constitute or be construed as a forcible entry by City.

(d) City may require Tenant to remove any and all Alterations from the Premises or, if Tenant fails to do so within ten (10) days after City's request, City may do so at Tenant's expense.

(e) City may cure the Event of Default at Tenant's expense, it being understood that such performance shall not waive or cure the subject Event of Default. If City pays any sum or incurs any expense in curing the Event of Default, Tenant shall reimburse City upon demand for the amount of such payment or expense with interest at the Interest Rate from the date the sum is paid or the expense is incurred until City is reimbursed by Tenant. Any amount due City under this subsection shall constitute additional rent hereunder.

17.3 Waiver of Redemption

Tenant hereby waives, for itself and all persons claiming by and under Tenant, all rights and privileges which it might have under any present or future Legal Requirement to redeem the Premises or to continue this Lease after being dispossessed or ejected from the Premises.

17.4 City's Right to Cure Tenant's Defaults

If Tenant defaults in the performance of any of its obligations under this Lease, then City may, at its sole option, remedy such default for Tenant's account and at Tenant's expense by

providing Tenant with three (3) days' prior written or oral notice of City's intention to cure such default (except that no such prior notice shall be required in the event of an emergency as determined by City). Such action by City shall not be construed as a waiver of such default or any rights or remedies of City, and nothing herein shall imply any duty of City to do any act that Tenant is obligated to perform. Tenant shall pay to City upon demand, as additional rent, all costs, damages, expenses or liabilities incurred by City, including, without limitation, reasonable attorneys' fees, in remedying or attempting to remedy such default. Tenant's obligations under this Section shall survive the termination of this Lease.

18. WAIVER OF CLAIMS; INDEMNIFICATION

18.1 Limitation on City's Liability; Waiver of Claims

City shall not be responsible for or liable to Tenant, and Tenant hereby assumes the risk of, and waives and releases City and its Agents from all Claims for; any injury, loss or damage to any person or property in or about the Premises by or from any cause whatsoever including, without limitation, (a) any act or omission of persons occupying adjoining premises or any part of the Building adjacent to or connected with the Premises, (b) theft, (c) explosion, fire, steam, oil, electricity, water, gas or rain, pollution or contamination, (d) stopped, leaking or defective Building Systems, (e) Building defects, and (f) any other acts, omissions or causes. Nothing in this Section shall relieve City from liability caused solely and directly by the gross negligence or willful misconduct of City or its Agents, but City shall not be liable under any circumstances for any consequential, incidental or punitive damages.

18.2 Tenant's Indemnity

Tenant, on behalf of itself and its successors and assigns, shall indemnify, defend and hold harmless ("Indemnify") City including, but not limited to, all of its boards, commissions, departments, agencies and other subdivisions, including, without limitation, its Real Estate Division, OEWD, Mayor's Office of Housing and Community Development, and all of its and their Agents, and their respective heirs, legal representatives, successors and assigns (individually, an "Indemnified Party" and collectively, the "Indemnified Parties"), and each of them, from and against any and all liabilities, losses, costs, claims, judgments, settlements, damages, liens, fines, penalties and expenses, including, without limitation, direct and vicarious liability of every kind (collectively, "Claims"), incurred in connection with or arising in whole or in part from: (a) any accident, injury to or death of a person, including, without limitation, employees of Tenant, or loss of or damage to property, howsoever or by whomsoever caused, occurring in or about the Premises; (b) any default by Tenant in the observation or performance of any of the terms, covenants or conditions of this Lease to be observed or performed on Tenant's part; (c) the use or occupancy or manner of use or occupancy of the Premises by Tenant, its Agents or Invitees or any person or entity claiming through or under any of them; (d) the condition of the Premises from and after the Effective Date; (e) any construction or other work undertaken by Tenant on the Premises whether before or during the Term of this Lease; or (f) any acts, omissions or negligence of Tenant, its Agents or Invitees, in, on or about the Premises, all regardless of the active or passive negligence of, and regardless of whether liability without fault is imposed or sought to be imposed on, the Indemnified Parties, except to the extent that such Indemnity is void or otherwise unenforceable under applicable law in effect on or validly retroactive to the date of this Lease and further except only to the extent such Claims are caused by or result from the willful misconduct or negligence of an Indemnified Party. The foregoing Indemnity shall include, without limitation, reasonable fees of attorneys, consultants

and experts and related costs and City's costs of investigating any Claim. Tenant specifically acknowledges and agrees that it has an immediate and independent obligation to defend the City from any claim which actually or potentially falls within this indemnity provision even if such allegation is or may be groundless, fraudulent or false, which obligation arises at the time such claim is tendered to Tenant by City and continues at all times thereafter. Tenant's obligations under this Section shall survive the termination of this Lease.

19. INSURANCE

19.1 Tenant's Insurance

(a) Tenant, at no cost to the City, shall procure and keep in effect at all times during the Term insurance as follows:

(i) Commercial general liability insurance with limits not less than Two Million Dollars (\$2,000,000) each occurrence combined single limit for bodily injury and property damage, including contractual liability, independent contractors, broad-form property damage, fire damage legal liability (of not less than Fifty Thousand Dollars (\$50,000)), personal injury, products and completed operations, and explosion, collapse and underground (XCU).

(ii) Worker's Compensation Insurance with Employer's Liability Limits not less than One Million Dollars (\$1,000,000) each accident.

(iii) Business automobile liability insurance with limits not less than One Million Dollars (\$1,000,000) each occurrence combined single limit for bodily injury and property damage, including owned and non-owned and hired vehicles, as applicable, if Tenant uses automobiles in connection with its use of the Premises.

(iv) Licensed professionals (i.e., architects, engineers, certified public accountants, etc.) shall provide professional liability insurance to Tenant with limits not less than \$1,000,000 each claim with respect to negligent acts, errors or omissions in connection with professional services to be provided under this Lease or to the Premises.

(v) Such other insurance as is generally required by commercial owners of buildings similar in size, character, age and location as the Building, as may change from time to time.

(b) At all times during any period of Tenant's construction of Tenant Improvements or any Alterations (to the extent City is requiring the following insurance during the construction of such Alteration), Tenant shall, at no cost to the City, comply with the following additional insurance requirements:

(i) Tenant shall require Tenant's contractor to maintain (a) commercial general liability insurance with limits of not less than Three Million Dollars (\$3,000,000) combined single limit for bodily injury and property damage (including personal injury and death), and contractor's protective liability; and products and completed operations coverage in an amount not less than Five Hundred Thousand Dollars (\$500,000) per incident, One Million Dollars (\$1,000,000) in the aggregate; (b) comprehensive automobile liability insurance with a policy limit of not less than One Million Dollars (\$1,000,000) each accident for bodily injury and property damage, providing coverage at least as broad as the Insurance Services Office (ISO) Business Auto Coverage form covering Automobile Liability, "any auto", and insuring against all loss in connection with the ownership, maintenance and operation of automotive equipment that is owned, hired or non-owned; (c) worker's compensation with statutory limits and employer's liability insurance with limits of not less than One Hundred Thousand Dollars (\$100,000) per accident, Five Hundred Thousand Dollars (\$500,000) aggregate disease coverage and One Hundred Thousand Dollars (\$100,000) disease coverage per

employee; and (d) contractor's pollution liability insurance with limits not less than \$1,000,000 each occurrence combined single limit.

(ii) Tenant shall cause Tenant's Agents (other than Tenant's contractor) to carry such insurance as shall be reasonably approved by City taking into account the nature and scope of the work and industry custom and practice.

(iii) Tenant shall carry "Builder's All Risk" insurance on a form reasonably approved by City, in the amount of one hundred percent (100%) of the completed value of all new construction, insuring all new construction, including all materials and equipment incorporated in, on or about the Premises, and in transit or storage off-site, that are or will be part of the permanent Improvements, against "all risk" and "special form" hazards, water damage (including groundwater damage and water damage resulting from backed up sewers and drains), and flood insurance.

(iv) Tenant shall require all providers of professional services, including architectural, design, engineering, geotechnical, and environmental professionals under contract with Tenant for any Tenant Improvements or any Alterations to maintain professional liability (errors or omissions) insurance, with limits not less than One Million Dollars (\$1,000,000.00) each claim and aggregate, with respect to all professional services provided to Tenant therefor.

(v) Should any of the insurance required to be maintained by Tenant (i.e., not by professionals retained by Tenant) be provided under a claims-made form, Tenant shall maintain such coverage continuously throughout the Term and, without lapse, for a period of three (3) years beyond the termination of this Lease, to the effect that, should occurrences during the Term give rise to claims made after the termination of this Lease, such claims shall be covered by such claims-made policies.

(c) Should any of the required insurance be provided under a form of coverage that includes a general annual aggregate limit or provides that claims investigation or legal defense costs be included in such general annual aggregate limit, such general aggregate limit shall double the occurrence or claims limits specified above.

(d) All liability insurance policies shall be endorsed to provide the following:

(i) Name as additional insured the City and County of San Francisco, its officers, agents and employees.

(ii) That such policies are primary insurance to any other insurance available to the additional insureds, with respect to any claims arising out of this Lease, and that insurance applies separately to each insured against whom claim is made or suit is brought.

(e) Each insurance policy required pursuant to Section 19.1(a) above shall be issued by an insurance company licensed in the State of California and with a general policyholders' rating of "A-" or better and a financial size ranking of "Class VIII" or higher in the most recent edition of Best's Insurance Guide.

(f) Tenant shall provide thirty (30) days' prior written notice of cancellation, intended non-renewal, or reduction in coverage for any reason of any insurance policies Tenant is required to maintain hereunder. Notice to City shall be mailed to the address(es) for City set forth in the Basic Lease Information.

(g) Tenant shall deliver to City certificates of insurance and additional insured policy endorsements from insurers for the policies required in Section 19.1(a) in a form satisfactory to City, evidencing the coverage required hereunder, on or before the Effective Date,

together with complete copies of the policies promptly upon City's request, and Tenant shall provide City with certificates or policies thereafter at least thirty (30) days before the expiration dates of expiring policies. Tenant shall deliver to City certificates of insurance and additional insured policy endorsements from insurers for the policies required in Section 19.1(b) in a form satisfactory to City, evidencing the coverage required hereunder, on or before the commencement of construction for the applicable Tenant Improvements or Alterations, together with complete copies of the policies promptly upon City's request, and Tenant shall provide City with certificates or policies thereafter at least thirty (30) days before the expiration dates of expiring policies. If Tenant fails to timely procure such insurance, or to timely deliver such policies or certificates, City may procure, at its option, without waiving any rights or remedies which City may have for Tenant's default hereunder, the same for the account of Tenant, and the cost thereof shall be paid to City within five (5) days after delivery to Tenant of bills therefor.

(h) Upon City's request, Tenant and City shall periodically review the limits and types of insurance carried pursuant to this Section. If the general commercial practice in the City and County of San Francisco is to carry liability insurance in an amount or coverage materially greater than the amount or coverage then being carried by Tenant for risks comparable to those associated with the Premises, then Tenant shall, at City's request, increase the amounts or coverage carried by Tenant to conform to such general commercial practice.

(i) Tenant's compliance with the provisions of this Section shall in no way relieve or decrease Tenant's liability under Section 18.2 (Tenant's Indemnity), or any of Tenant's other obligations under this Lease.

(j) Notwithstanding anything to the contrary in this Lease, if any of the required insurance coverage lapses, this Lease shall terminate upon three (3) days' notice to Tenant, unless Tenant renews the insurance coverage within notice period.

19.2 Tenant's Personal Property

Tenant shall be responsible, at no cost to the City, for separately insuring Tenant's Personal Property.

19.3 City's Self Insurance

Tenant acknowledges that City self-insures against casualty, property damage and public liability risks and agrees that City may at its sole election, but shall not be required to, carry any third party insurance with respect to the Building, the Premises or otherwise.

19.4 Waiver of Subrogation

Notwithstanding anything to the contrary in this Lease, City and Tenant (each a "Waiving Party") each hereby waives any right of recovery against the other party for any loss or damage relating to the Building or the Premises or any operations or contents therein, whether or not such loss is caused by the fault or negligence of such other party, to the extent such loss or damage is covered by third party insurance that is required to be purchased by the Waiving Party under this Lease or is actually covered by insurance held by the Waiving Party or its agents, or, in the case of City, since it does not carry insurance, to the extent such loss or damage would have been covered by the insurance customarily maintained by institutional property owners. Each Waiving Party agrees to obtain a waiver of subrogation rights endorsements from applicable insurance carriers issuing policies relating to the Building or the Premises; provided, the failure to obtain any such endorsement shall not affect the above waiver.

20. ACCESS BY CITY

City reserves for itself and any of its designated Agents, the right to enter the Premises as follows: (a) on a regular basis without advance notice to supply any necessary or agreed-upon service to be provided by City hereunder; (b) on an occasional basis, at all reasonable times after giving Tenant reasonable advance written or oral notice, to show the Premises to prospective tenants or other interested parties, to post notices of non-responsibility, to conduct any environmental audit of Tenant's use of the Premises, to repair, alter or improve any part of the Building, Building Systems or the Premises, and for any other lawful purpose; and (c) on an emergency basis without notice whenever City believes that emergency access is required. City shall have the right to use any means that it deems proper to open doors in an emergency in order to obtain access to any part of the Premises, and any such entry shall not be construed or deemed to be a forcible or unlawful entry into or a detainer of, the Premises, or an eviction, actual or constructive, of Tenant from the Premises or any portion thereof. Tenant shall not alter any lock or install any new or additional locking devices without the prior written consent of City. All locks installed in the Premises (excluding Tenant's vaults, safes or special security areas, if any; designated by Tenant in writing to City) shall be keyed to the Building master key system, and City shall at all times have a key with which to unlock all such doors.

21. CERTIFICATES

21.1 Tenant's Estoppel Certificates

Tenant, at any time and from time to time upon not less than ten (10) days' prior notice from City, shall execute and deliver to City or to any party designated by City a certificate stating: (a) that Tenant has accepted the Premises, (b) the Effective Date, the Rent Commencement Date, and the Outside Date, (c) that this Lease is unmodified and in full force and effect (or, if there have been modifications, that the Lease is in full force and effect as modified and stating the modifications), (d) whether or not there are then existing any defenses against the enforcement of any of Tenant's obligations hereunder (and if so, specifying the same), (e) whether or not there are any defaults then existing under this Lease (and if so specifying the same), (f) the dates, if any, to which the Base Rent, Percentage Rent, and Additional Charges have been paid, and (g) any other information that may be required.

21.2 City's Certificates

City, at any time and from time to time upon not less than ten (10) days' prior notice from Tenant, shall execute and deliver to Tenant or to any party designated by Tenant a certificate stating: (a) the Effective Date, the Rent Commencement Date, and the Outside Date, (b) that this Lease is unmodified and in full force and effect (or, if there have been modifications, that the Lease is in full force and effect as modified and stating the modifications), (c) whether or not there are any defaults then existing under this Lease (and if so specifying the same), (d) the dates, if any, to which the Base Rent, Percentage Rent, and Additional Charges have been paid, and (e) any other information that may be required.

22. RULES AND REGULATIONS

Tenant shall faithfully comply with the rules and regulations attached to this Lease as Exhibit H (Building Rules and Regulations) and all modifications thereof and additions thereto that City may from time to time put into effect (the "Rules and Regulations"). City shall not be responsible for the non-performance of the Rules and Regulations by any other tenant or occupant of the Building. In the event of any conflict between any provision of this Lease and any provision of the Rules and Regulations, this Lease shall control.

23. [Intentionally deleted]

24. SURRENDER OF PREMISES

City anticipates demolishing the Building following the termination of this Lease. Upon the termination of this Lease, Tenant shall peaceably quit and surrender to City the Premises in broom clean condition, together with the Tenant Improvements and all Alterations approved by City, except for any portion of the Premises condemned and any damage and destruction for which Tenant is not responsible hereunder. If this Lease terminates prior to the Rent Commencement Date, Tenant shall cause the Leasehold Improvement Work completed as of such termination date to be in a safe condition. The Premises shall be surrendered free and clear of all liens and encumbrances other than liens and encumbrances existing as of the date of this Lease and any other encumbrances created by City. Except as otherwise set forth in Section 25, immediately before the termination of this Lease, Tenant shall remove all of Tenant's Personal Property as provided in this Lease, using commercially reasonable efforts to avoid any damage to any portion of the Premises. If such removal is not completed at the termination of this Lease, City may remove the same at Tenant's expense. Tenant's obligations under this Section shall survive the termination of this Lease. Any items of Tenant's Personal Property remaining in the Premises after the termination of this Lease may, at City's option, be deemed abandoned and disposed of in accordance with Section 1980 et seq. of the California Civil Code or in any other manner allowed by law.

Concurrently with the surrender of the Premises, Tenant shall, if requested by City, execute, acknowledge and deliver to City a quitclaim deed to the Premises and any other instrument reasonably requested by City to evidence or otherwise effect the termination of Tenant's leasehold estate hereunder and to effect such transfer or vesting of title to the Tenant Improvements or other improvements or equipment which remain part of the Premises. The terms of this Section shall survive the termination of this Lease.

25. REMOVAL OF ELECTRICAL AND TELECOMMUNICATIONS WIRES

25.1 City May Elect to Remove or Retain Wires

Within thirty (30) days after the termination of this Lease or at any time that the Wires (as defined below) are no longer in active use by Tenant, City may elect by written notice to Tenant to: (a) retain any or all wires, cables and similar installations appurtenant thereto (the "Wires") installed by or on behalf of Tenant within the Premises or any portion of the Building outside the Premises, including, without limitation, the plenums or risers of the Building; or (b) remove any or all of the Wires.

25.2 Compliance with Laws and Discontinuance of Wire Use

Tenant shall comply with all applicable laws with respect to the Wires, subject to City's right to elect to retain the Wires. Within thirty (30) days after Tenant discontinues the use of all or any part of the Wires, Tenant shall deliver to City written notice of such discontinuance, together with a plan or other reasonable description of the current type, quantity, points of commencement and termination, and routes of the Wires to allow City to determine if City desires to retain the Wires.

25.3 Condition of Wires

Tenant covenants that as of the termination of this Lease, Tenant will be the sole owners of the Wires, Tenant will have the sole right to surrender the Wires, and the Wires shall be free of all liens and encumbrances.

25.4 Survival

The terms of this Section shall survive the termination of this Lease.

26. HAZARDOUS MATERIALS

26.1 Definitions

As used herein, the following terms shall have the meanings set forth below:

(a) "Environmental Laws" shall mean any present or future federal, state, local or administrative law, rule, regulation, order or requirement relating to Hazardous Material (including, without limitation, its use, handling, transportation, production, disposal, discharge or storage), or to health and safety, industrial hygiene or the environment, including, without limitation, soil, air and groundwater conditions.

(b) "Hazardous Material" shall mean any material that, because of its quantity, concentration or physical or chemical characteristics, is at any time now or hereafter deemed by any federal, state or local governmental authority to pose a present or potential hazard to human health, welfare or safety or to the environment. Hazardous Material includes, without limitation, any material or substance defined as a "hazardous substance," or "pollutant" or "contaminant" pursuant to the Comprehensive Environmental Response, Compensation and Liability Act of 1980 ("CERCLA", also commonly known as the "Superfund" law), as amended, (42 U.S.C. Section 9601 et seq.) or pursuant to Section 25316 of the California Health & Safety Code; any "hazardous waste" listed pursuant to Section 25140 of the California Health & Safety Code; and petroleum, including crude oil or any fraction thereof, natural gas or natural gas liquids.

(c) "Investigate and Remediate" ("Investigation" and "Remediation") shall mean the undertaking of any activities to determine the nature and extent of Hazardous Material that may be located in, on, under or about the Premises or that has been, are being or threaten to be Released into the environment, and to clean up, remove, contain, treat, stabilize, monitor or otherwise control such Hazardous Material.

(d) "Release" when used with respect to Hazardous Material shall include any actual or imminent spilling, leaking, pumping, pouring, emitting, emptying, discharging, injecting, escaping, leaching, dumping, or disposing into or inside the Building, or in, on, under or about any other part of the Premises or into the environment.

26.2 No Hazardous Materials

Tenant acknowledges there is asbestos in the black mastic used to affix the mirrors to the walls in the restrooms and may be other Hazardous Material at the Premises. Tenant covenants and agrees that neither Tenant nor any of its Agents or Invitees shall cause or permit any Hazardous Material to be brought upon, kept, used, stored, generated or disposed of in, on or about the Premises, or transported to or from the Premises, with the sole exception that Tenant may keep and use such substances in the Building in such reasonably limited amounts as are customarily used for general office, cleaning, janitorial and cooking purposes and may generate such substances as a result of measures taken pursuant to Articles 7 or 8 of this Lease that disturb or remove lead-based or presumed lead-based paint from the exterior or interior surfaces of the Premises so long as such generation, storage, transportation, use, and disposal are in compliance with all applicable Environmental Laws at all times. Tenant shall give immediate written notice to City of: (a) any action, proceeding or inquiry by any governmental authority (including, without limitation, the California State Department of Health Services, the State or any Regional Water Quality Control Board, the Bay Area Air Quality Management district or any local governmental entity) against Tenant with respect to the presence or Release or suspected presence or Release of Hazardous Material on the Premises or the migration thereof from or to

other property; (b) all demands or claims made or threatened by any third party against Tenant or the Premises relating to any loss or injury resulting from any Hazardous Materials; (c) any Release of Hazardous Material on or about the Premises has occurred that may require any Investigation or Remediation; and (d) all matters of which Tenant is required to give notice pursuant to Section 25359.7 of the California Health and Safety Code.

26.3 Tenant's Environmental Indemnity

If Tenant breaches any of its obligations contained in this Section, or, if any act or omission of Tenant, its Agents or Invitees, results in any Release of Hazardous Material in, on, under or about the Premises in violation of any applicable Environmental Laws, including but not limited to Chapter 36 of the San Francisco Building Code, then, without limiting Tenant's Indemnity contained in Section 18.2 (Tenant's Indemnity), Tenant shall, on behalf of itself and its successors and assigns, Indemnify the Indemnified Parties, and each of them, from and against all Claims (including, without limitation, sums paid in settlement of claims, attorneys' fees, consultants' fees and experts' fees and costs) arising during or after the Term of this Lease and relating to such Release. The foregoing Indemnity includes, without limitation, costs incurred in connection with activities undertaken to Investigate and Remediate Hazardous Material and to restore the Premises to its prior condition, fines and penalties assessed for the violation of any applicable Environmental Laws including but not limited to Chapter 36 of the San Francisco Building Code, and any natural resource damages. Without limiting the foregoing, if Tenant or any of its Agents or Invitees, causes or permits the Release of any Hazardous Materials in, on, under or about the Premises, Tenant shall immediately and at no expense to City take any and all appropriate actions to return the Premises affected thereby to the condition existing prior to such Release and otherwise Investigate and Remediate the Release in accordance with all Environmental Laws. Tenant specifically acknowledges and agrees that it has an immediate and independent obligation to defend the City from any claim which actually or potentially falls within this indemnity provision even if such allegation is or may be groundless, fraudulent or false, which obligation arises at the time such claim is tendered to Tenant by the City and continues at all times thereafter. Tenant shall afford City a full opportunity to participate in any discussions with governmental regulatory agencies regarding any settlement agreement, cleanup or abatement agreement, consent decree, or other compromise or proceeding involving Hazardous Material.

26.4 Survival of Obligation

Tenant's obligations under this Section 26 shall survive the termination of this Lease.

27. GENERAL PROVISIONS

27.1 Notices

Any notice given under this Lease shall be effective only if in writing and given by delivering the notice in person or by sending it first-class mail or certified mail with a return receipt requested or by overnight courier, return receipt requested, with postage prepaid, to: (a) Tenant, (i) at Tenant's address set forth in the Basic Lease Information, if sent prior to Tenant's taking possession of the Premises, or (ii) at the Premises if sent on or subsequent to Tenant's taking possession of the Premises, or (iii) at any place where Tenant or any Agent of Tenant may be found if sent subsequent to Tenant's vacating, abandoning or surrendering the Premises; or (b) City, at City's address set forth in the Basic Lease Information; or (c) to such other address as either City or Tenant may designate as its new address for such purpose by notice given to the other in accordance with the provisions of this Section at least ten (10) days prior to the effective date of such change. Any notice hereunder shall be deemed to have been given two (2) days after the date when it is mailed if sent by first class or certified mail, one day after the date it is made if sent by overnight courier, or upon the date personal delivery is made. For convenience of the parties, copies of notices may also be given by telefacsimile to the City at

the telefacsimile number set forth in the Basic Lease Information or such other number as may be provided from time to time; however, Tenant may not give official or binding notice to City by facsimile. Tenant shall promptly provide City with copies of any and all notices received regarding any alleged violation of laws or insurance requirements or any alleged unsafe condition or practice.

27.2 No Implied Waiver

No failure by City to insist upon the strict performance of any obligation of Tenant under this Lease or to exercise any right, power or remedy arising out of a breach thereof, irrespective of the length of time for which such failure continues, no acceptance of full or partial Base Rent, Percentage Rent, or Additional Charges during the continuance of any such breach, and no acceptance of the keys to or possession of the Premises prior to the termination of this Lease by any Agent of City, shall constitute a waiver of such breach or of City's right to demand strict compliance with such term, covenant or condition or operate as a surrender of this Lease. No express written waiver of any default or the performance of any provision hereof shall affect any other default or performance, or cover any other period of time, other than the default, performance or period of time specified in such express waiver. One or more written waivers of a default or the performance of any provision hereof shall not be deemed to be a waiver of a subsequent default or performance. Any consent by City hereunder shall not relieve Tenant of any obligation to secure the consent of City in any other or future instance under the terms of this Lease.

27.3 Amendments

Neither this Lease nor any terms or provisions hereof may be changed, waived, discharged or terminated, except by a written instrument signed by the party against which the enforcement of the change, waiver, discharge or termination is sought. No waiver of any breach shall affect or alter this Lease, but each and every term, covenant and condition of this Lease shall continue in full force and effect with respect to any other then-existing or subsequent breach thereof. Whenever this Lease requires or permits the giving by City of its consent or approval, the Director of Property, or his or her designee shall be authorized to provide such approval, except as otherwise provided by applicable law, including the Charter. Any amendments or modifications to this Lease, including, without limitation, amendments to or modifications to the exhibits to this Lease, shall be subject to the mutual written agreement of City and Tenant, and City's agreement may be made upon the sole approval of the Director of Property, or his or her designee; provided, however, material amendments or modifications to this Lease (a) changing the legal description of the Premises, (b) increasing the Term, (c) increasing the Rent, (d) changing the general use of the Premises from the use authorized under Section 5.1 (Permitted Use) of this Lease, and (e) any other amendment or modification which materially increases the City's liabilities or financial obligations under this Lease shall additionally require the approval of the City's Board of Supervisors.

27.4 Authority

If Tenant signs as a corporation or a partnership, each of the persons executing this Lease on behalf of Tenant does hereby covenant and warrant that Tenant is a duly authorized and existing entity, that Tenant has and is qualified to do business in California, that Tenant has full right and authority to enter into this Lease, and that each and all of the persons signing on behalf of Tenant are authorized to do so. Upon City's request, Tenant shall provide City with evidence reasonably satisfactory to City confirming the foregoing representations and warranties.

27.5 Parties and Their Agents; Approvals

The words "City" and "Tenant" as used herein shall include the plural as well as the singular. If there is more than one Tenant, the obligations and liabilities under this Lease

imposed on Tenant shall be joint and several. As used herein, the term "Agents" when used with respect to either party shall include the agents, employees, officers, contractors and representatives of such party, and the term "Invitees" when used with respect to Tenant shall include the clients, customers, invitees, guests, licensees, assignees or subtenants of Tenant. All approvals, consents or other determinations permitted or required by City hereunder shall be made by or through City's Director of Property unless otherwise provided in this Lease, subject to applicable law.

27.6 Interpretation of Lease

The captions preceding the articles and sections of this Lease and in the table of contents have been inserted for convenience of reference only and such captions shall in no way define or limit the scope or intent of any provision of this Lease. This Lease has been negotiated at arm's length and between persons sophisticated and knowledgeable in the matters dealt with herein and shall be interpreted to achieve the intents and purposes of the parties, without any presumption against the party responsible for drafting any part of this Lease. Provisions in this Lease relating to number of days shall be calendar days, unless otherwise specified, provided that if the last day of any period to give notice, reply to a notice or to undertake any other action occurs on a Saturday, Sunday or a bank or City holiday, then the last day for undertaking the action or giving or replying to the notice shall be the next succeeding business day. Use of the word "including" or similar words shall not be construed to limit any general term, statement or other matter in this Lease, whether or not language of non-limitation, such as "without limitation" or similar words, are used.

27.7 Successors and Assigns

Subject to the provisions of this Lease relating to Assignments and Subleases, the terms, covenants and conditions contained in this Lease shall bind and inure to the benefit of City and Tenant and, except as otherwise provided herein, their personal representatives and successors and assigns; provided, however, that upon any sale, assignment or transfer by City named herein (or by any subsequent landlord) of its interest in the Building as owner or lessee, including any transfer by operation of law, City (or any subsequent landlord) shall be relieved from all subsequent obligations and liabilities arising under this Lease subsequent to such sale, assignment or transfer.

27.8 Brokers

Neither party has had any contact or dealings regarding the leasing of the Premises, or any communication in connection therewith, through any licensed real estate broker or other person who could claim a right to a commission or finder's fee in connection with the lease contemplated herein except as identified in the Basic Lease Information, whose commission, if any is due, shall be paid pursuant to a separate written agreement between such broker and the party through which such broker contracted. In the event that any broker or finder perfects a claim for a commission or finder's fee based upon any such contact, dealings or communication, the party through whom the broker or finder makes a claim shall be responsible for such commission or fee and shall indemnify the other party from any and all Claims incurred by the indemnified party in defending against the same. The provisions of this Section shall survive any termination of this Lease.

27.9 Severability

If any provision of this Lease or the application thereof to any person, entity or circumstance shall be invalid or unenforceable, the remainder of this Lease, or the application of such provision to persons, entities or circumstances other than those as to which it is invalid or unenforceable, shall not be affected thereby, and each other provision of this Lease shall be valid and be enforceable to the fullest extent permitted by law, except to the extent that enforcement of

this Lease without the invalidated provision would be unreasonable or inequitable under all the circumstances or would frustrate a fundamental purpose of this Lease.

27.10 Governing Law

This Lease shall be construed and enforced in accordance with the laws of the State of California and the City's Charter.

27.11 Entire Agreement

This instrument, including the exhibits hereto, which are made a part of this Lease, contains the entire agreement between the parties and all prior written or oral negotiations, understandings and agreements are merged herein. The parties further intend that this Lease shall constitute the complete and exclusive statement of its terms and that no extrinsic evidence whatsoever (including prior drafts hereof and changes therefrom) may be introduced in any judicial, administrative or other legal proceeding involving this Lease. Tenant hereby acknowledges that neither City nor City's Agents have made any representations or warranties with respect to the Premises, the Building or this Lease except as expressly set forth herein, and no rights, easements or licenses are or shall be acquired by Tenant by implication or otherwise unless expressly set forth herein.

27.12 Attorneys' Fees

In the event that either City or Tenant fails to perform any of its obligations under this Lease or in the event a dispute arises concerning the meaning or interpretation of any provision of this Lease, the defaulting party or the non-prevailing party in such dispute, as the case may be, shall pay the prevailing party reasonable attorneys' and experts' fees and costs, and all court costs and other costs of action incurred by the prevailing party in connection with the prosecution or defense of such action and enforcing or establishing its rights hereunder (whether or not such action is prosecuted to a judgment). For purposes of this Lease, the terms "court costs and reasonable attorneys' fees" shall mean the fees and expenses of counsel to the Parties, which may include printing, duplicating and other expenses, air freight charges, hiring of experts, and fees billed for law clerks, paralegals, librarians and others not admitted to the bar but performing services under the supervision of an attorney. The term "court costs and attorneys' fees" shall also include, without limitation, all such fees and expenses incurred with respect to appeals, mediation, arbitrations, and bankruptcy proceedings, and whether or not any action is brought with respect to the matter for which such fees and costs were incurred. For the purposes of this Lease, reasonable fees of attorneys of City's Office of the City Attorney shall be based on the fees regularly charged by private attorneys with the equivalent number of years of experience in the subject matter area of the law for which the City Attorney's services were rendered who practice in the City of San Francisco in law firms with approximately the same number of attorneys as employed by the Office of the City Attorney.

27.13 Holding Over

Tenant acknowledges that if it holds over at the Premises following the termination of this Lease without City's consent could result in substantial City costs and expenses with respect to the development or other use of the Premises. Without limiting City's other rights and remedies set forth in this Lease, at law, or in equity, if Tenant retains possession of any portion of the Premises after the termination of this Lease, then unless City expressly agrees to the holdover in writing, Tenant shall pay City, on a month-to-month basis the Base Rent payable by Tenant hereunder prior to such termination, together with monthly payments equal to forty percent (40%) of Net Income (the "Holdover Payment") and an amount estimated by City for the monthly Additional Charges payable under this Lease, and shall otherwise be on the terms and conditions herein specified so far as applicable (except for those pertaining to the Term). Any failure by Tenant to surrender, discontinue using, or, if required by City, any failure to remove

any property or equipment following written demand for the same by City, shall constitute continuing possession for purposes hereof. Tenant acknowledges that the foregoing provisions shall not serve as permission for the Tenant to hold over, nor serve to extend the term of this Lease beyond the end on the term hereof. Any holding over without City's consent shall constitute a default by Tenant and entitle City to exercise any or all of its remedies as provided herein, notwithstanding that City may elect to accept one or more payments of Rent, and whether or not such amounts are at the holdover rate specified above or the rate in effect at the end of the Term of this Lease. Any holding over after the termination of this Lease with the express consent of City shall be construed to automatically extend the Term of this Lease on a month-to-month basis at a Base Rent equal to the latest Base Rent payable by Tenant hereunder prior to such termination, together with Percentage Rent and the amount estimated by City for the monthly Additional Charges payable under this Lease, and shall otherwise be on the terms and conditions herein specified so far as applicable (except for those pertaining to the Term).

During any period of holding over, Tenant shall provide monthly statements (each, a "Monthly Statement") for the immediately preceding month in a form approved by City and setting forth in reasonable detail the Gross Revenues for the immediately preceding month, including an itemized list of any and all deductions or exclusions from Gross Revenues that Tenant may claim and which are expressly permitted under this Lease, the Expenses for the immediately preceding month, and a computation of the Percentage Rent or the Holdover Payment, as applicable, for the immediately preceding month. Each Monthly Statement shall be certified as accurate, complete and current by Tenant's president and chief financial officer. Within the sixty (60) day period immediately following Tenant's vacation of the Premises after any period of holding over, Tenant shall provide a final statement (the "Final Statement"), certified as accurate, complete and current by an independent certified public accounting firm acceptable to City's Director of Property in his or her sole discretion and in a form approved by City, setting forth in reasonable detail the Gross Revenues for such period, including an itemized list of any and all deductions or exclusions from Gross Revenues that Tenant may claim and which are expressly permitted under this Lease, the Expenses for such period, and a computation of the Percentage Rent or Holdover Payments, as applicable, for such period. If the Final Statement shows Tenant underpaid the Percentage Rent or Holdover Payments, as applicable, for the holdover period, Tenant shall deliver the remaining amount owed to City within thirty (30) days of receiving City's invoice therefor, together with interest from the date of the error in the payment equal to ten percent (10%) per year or, if a higher rate is legally permissible, the highest rate an individual is permitted to charge under applicable law, if City elects, in its sole discretion, to charge such interest. If an audit reveals that Tenant has overpaid Percentage Rent or Holdover Payments, as applicable, for the holdover period, within sixty (60) days of receiving the Final Statement, City shall reimburse Tenant in an amount equal to the amount Tenant has overpaid.

If Tenant fails to deliver any Monthly Statement or Final Statement within the time period set forth in this Section (irrespective of whether any Percentage Rent or Holdover Payment, as applicable, is actually paid or due to City for the applicable period) and such failure continues for three (3) days after the date Tenant receives (or refuses receipt of) written notice of such failure from City, City shall have the right, among its other remedies under this Lease, to employ a certified public accountant to make such examination of the Books and Records of Tenant and of any other occupant of the Premises as may be necessary to certify the amount of the Gross Revenues and Expenses for the period in question. Such certification shall be binding upon Tenant and Tenant shall promptly pay to City the total reasonable cost of the examination and City's other reasonable costs (including attorneys' fees) in exercising its examination rights hereunder, together with the full amount of Percentage Rent or Holdover Payment, as applicable, due and payable for the period in question. Tenant acknowledges that the late submittal of any Monthly Statement or Final Statement will cause City increased costs not contemplated by this Lease, the exact amount of which will be extremely difficult to ascertain. The parties agree that the charges set forth in this Section represent a fair and reasonable estimate of the cost that City will incur by reason of Tenant's lateness.

Tenant's obligations under this Section shall survive the termination of this Lease.

27.14 Time of Essence

Time is of the essence with respect to all provisions of this Lease in which a definite time for performance is specified.

27.15 Cumulative Remedies

All rights and remedies of either party hereto set forth in this Lease shall be cumulative, except as may otherwise be provided herein.

27.16 Survival of Indemnities

Termination of this Lease shall not affect the right of either party to enforce any and all indemnities and representations and warranties given or made to the other party under this Lease, nor shall it affect any provision of this Lease that expressly states it shall survive termination hereof.

27.17 Signs

Tenant agrees that it will not erect or maintain, or permit to be erected or maintained, any signs, notices or graphics upon or about the Premises which are visible from the exterior of the Premises, without City's prior written consent, which City may withhold or grant in its sole discretion.

27.18 Relationship of the Parties

City is not, and none of the provisions in this Lease shall be deemed to render City, a partner in Tenant's business, or joint venturer or member in any joint enterprise with Tenant. Neither party shall act as the agent of the other party in any respect hereunder. This Lease is not intended nor shall it be construed to create any third party beneficiary rights in any third party, unless otherwise expressly provided.

27.19 Light and Air

Tenant covenants and agrees that no diminution of light, air or view by any structure that may hereafter be erected (whether or not by City) shall entitle Tenant to any reduction of the Base Rent, Percentage Rent, or Additional Charges under this Lease, result in any liability of City to Tenant, or in any other way affect this Lease or Tenant's obligations hereunder.

27.20 No Recording

Tenant shall not record this Lease or any memorandum hereof in the public records.

27.21 Public Transit Information

Tenant shall establish and carry on during the Term a program to encourage maximum use of public transportation by personnel of Tenant employed on the Premises, including, without limitation, the distribution to such employees of written materials explaining the convenience and availability of public transportation facilities adjacent or proximate to the Building and encouraging use of such facilities, all at Tenant's sole expense.

27.22 Taxes, Assessments, Licenses, Permit Fees and Liens

(a) Tenant recognizes and understands that this Lease may create a possessory interest subject to property taxation and that Tenant may be subject to the payment of property taxes levied on such interest.

(b) Tenant agrees to pay taxes of any kind, including possessory interest taxes, that may be lawfully assessed on the leasehold interest hereby created and to pay all other taxes, excises, licenses, permit charges and assessments based on Tenant's usage of the Premises that may be imposed upon Tenant by law, all of which shall be paid when the same become due and payable and before delinquency.

(c) Tenant agrees not to allow or suffer a lien for any such taxes to be imposed upon the Premises or upon any equipment or property located thereon without promptly discharging the same, provided that Tenant, if so desiring, may have reasonable opportunity to contest the validity of the same.

(d) San Francisco Administrative Code Sections 23.38 and 23.39 require that the City and County of San Francisco report certain information relating to this Lease, and any renewals thereof, to the County Assessor within sixty (60) days after any such transaction, and that Tenant report certain information relating to any assignment of or sublease under this Lease to the County Assessor within sixty (60) days after such assignment or sublease transaction. Tenant agrees to provide such information as may be requested by the City to enable the City to comply with this requirement.

27.23 Non-Liability of City Officials, Employees and Agents

No elective or appointive board, commission, member, officer, employee or other Agent of City shall be personally liable to Tenant, its successors and assigns, in the event of any default or breach by City or for any amount which may become due to Tenant, its successors and assigns, or for any obligation of City under this Agreement.

27.24 Non-Discrimination in City Contracts and Benefits Ordinance

(a) Covenant Not to Discriminate

In the performance of this Lease, Tenant agrees not to discriminate against any employee, any City employee working with Tenant, or applicant for employment with Tenant, or against any person seeking accommodations, advantages, facilities, privileges, services, or membership in all business, social, or other establishments or organizations, on the basis of the fact or perception of a person's race, color, creed, religion, national origin, ancestry, age, height, weight, sex, sexual orientation, gender identity, domestic partner status, marital status, disability or Acquired Immune Deficiency Syndrome or HIV status (AIDS/HIV status), or association with members of such protected classes, or in retaliation for opposition to discrimination against such classes.

(b) Subleases and Other Subcontracts

Tenant shall include in all Subleases and other subcontracts relating to the Premises a non-discrimination clause applicable to such Subtenant or other subcontractor in substantially the form of subsection (a) above. In addition, Tenant shall incorporate by reference in all subleases and other subcontracts the provisions of Sections 12B.2(a), 12B.2(c)-(k), and 12C.3 of the San Francisco Administrative Code and shall require all subtenants and other subcontractors to comply with such provisions. Tenant's failure to comply with the obligations in this subsection shall constitute a material breach of this Lease.

(c) Non-Discrimination in Benefits

Tenant does not as of the date of this Lease and will not during the term of this Lease, in any of its operations in San Francisco, on real property owned by City, or where the work is being performed for the City elsewhere within the United States, discriminate in the provision of bereavement leave, family medical leave, health benefits, membership or membership discounts, moving expenses, pension and retirement benefits or travel benefits, as well as any benefits other than the benefits specified above; between employees with domestic partners and employees with spouses, and/or between the domestic partners and spouses of such employees, where the domestic partnership has been registered with a governmental entity pursuant to state or local law authorizing such registration, subject to the conditions set forth in Section 12B.2(b) of the San Francisco Administrative Code.

(d) CMD Form

As a condition to this Lease, Tenant shall execute the "Chapter 12B Declaration: Nondiscrimination in Contracts and Benefits" form (Form CMD-12B-101) with supporting documentation and secure the approval of the form by the San Francisco Contract Monitoring Division. Tenant hereby represents that prior to execution of this Lease, (i) Tenant executed and submitted to the CMD Form CMD-12B-101 with supporting documentation, and (ii) the CMD approved such form.

(e) Incorporation of Administrative Code Provisions by Reference

The provisions of Chapters 12B and 12C of the San Francisco Administrative Code relating to non-discrimination by parties contracting for the lease of City property are incorporated in this Section by reference and made a part of this Agreement as though fully set forth herein. Tenant shall comply fully with and be bound by all of the provisions that apply to this Lease under such Chapters of the Administrative Code, including but not limited to the remedies provided in such Chapters. Without limiting the foregoing, Tenant understands that pursuant to Section 12B.2(h) of the San Francisco Administrative Code, a penalty of Fifty Dollars (\$50) for each person for each calendar day during which such person was discriminated against in violation of the provisions of this Lease may be assessed against Tenant and/or deducted from any payments due Tenant.

27.25 No Relocation Assistance; Waiver of Claims

Tenant acknowledges that it will not be a displaced person at the time this Lease is terminated or expires by its own terms, and Tenant fully RELEASES, WAIVES AND DISCHARGES forever any and all Claims against, and covenants not to sue, City, its departments, commissions, officers, directors and employees, and all persons acting by, through or under each of them, under any laws, including, without limitation, any and all claims for relocation benefits or assistance from City under federal and state relocation assistance laws (including, but not limited to, California Government Code Section 7260 et seq.), except as otherwise specifically provided in this Lease with respect to a Taking.

27.26 MacBride Principles - Northern Ireland

The provisions of San Francisco Administrative Code §12F are incorporated herein by this reference and made part of this Lease. By signing this Lease, Tenant confirms that Tenant has read and understood that the City urges companies doing business in Northern Ireland to resolve employment inequities and to abide by the MacBride Principles, and urges San Francisco companies to do business with corporations that abide by the MacBride Principles.

27.27 Tropical Hardwood and Virgin Redwood Ban

The City and County of San Francisco urges companies not to import, purchase, obtain or use for any purpose, any tropical hardwood, tropical hardwood wood product, virgin redwood or virgin redwood wood product. Except as expressly permitted by the application of Sections 802(b) and 803(b) of the San Francisco Environment Code, Tenant shall not provide any items to the construction of Tenant Improvements or the Alterations, or otherwise in the performance of this Lease which are tropical hardwoods, tropical hardwood wood products, virgin redwood, or virgin redwood wood products. In the event Tenant fails to comply in good faith with any of the provisions of Chapter 8 of the San Francisco Environment Code, Tenant shall be liable for liquidated damages for each violation in any amount equal to Tenant's net profit on the contract, or five percent (5%) of the total amount of the contract dollars, whichever is greater.

27.28 Restrictions on the Use of Pesticides

Chapter 3 of the San Francisco Environment Code (the Integrated Pest Management Program Ordinance or "IPM Ordinance") describes an integrated pest management ("IPM") policy to be implemented by all City departments. Tenant shall not use or apply or allow the use or application of any pesticides on the Premises or contract with any party to provide pest abatement or control services to the Premises without first receiving City's written approval of an IPM plan that (i) lists, to the extent reasonably possible, the types and estimated quantities of pesticides that Tenant may need to apply to the Premises during the term of this Lease, (ii) describes the steps Tenant will take to meet the City's IPM Policy described in Section 300 of the IPM Ordinance, and (iii) identifies, by name, title, address and telephone number, an individual to act as the Tenant's primary IPM contact person with the City. Tenant shall comply, and shall require all of Tenant's contractors to comply, with the IPM plan approved by the City and shall comply with the requirements of Sections 300(d), 302, 304, 305(f), 305(g), and 306 of the IPM Ordinance, as if Tenant were a City department. Among other matters, such provisions of the IPM Ordinance: (a) provide for the use of pesticides only as a last resort, (b) prohibit the use or application of pesticides on property owned by the City, except for pesticides granted an exemption under Section 303 of the IPM Ordinance (including pesticides included on the most current Reduced Risk Pesticide List compiled by City's Department of the Environment), (c) impose certain notice requirements, and (d) require Tenant to keep certain records and to report to City all pesticide use at the Premises by Tenant's staff or contractors.

If Tenant or Tenant's contractor will apply pesticides to outdoor areas at the Premises, Tenant must first obtain a written recommendation from a person holding a valid Agricultural Pest Control Advisor license issued by the California Department of Pesticide Regulation ("CDPR") and any such pesticide application shall be made only by or under the supervision of a person holding a valid, CDPR-issued Qualified Applicator certificate or Qualified Applicator license. City's current Reduced Risk Pesticide List and additional details about pest management on City property can be found at the San Francisco Department of the Environment website, <http://sfenvironment.org/ipm>.

27.29 First Source Hiring Agreement

Tenant and City are parties to the First Source Agreement attached to this Lease as Exhibit I pursuant to San Francisco Administrative Code, Chapter 83 (the "First Source Agreement"). Any default by Tenant under the First Source Agreement shall be a default under this Lease.

27.30 Sunshine Ordinance

In accordance with Section 67.24(e) of the San Francisco Administrative Code, contracts, contractors' bids, leases, agreements, responses to Requests for Proposals, and all other records

of communications between City and persons or firms seeking contracts will be open to inspection immediately after a contract has been awarded. Nothing in this provision requires the disclosure of a private person's or organization's net worth or other proprietary financial data submitted for qualification for a contract, lease, agreement or other benefit until and unless that person or organization is awarded the contract, lease, agreement or benefit. Information provided which is covered by this Section will be made available to the public upon request.

27.31 Conflicts of Interest

Through its execution of this Lease, Tenant acknowledges that it is familiar with the provisions of Article III, Chapter 2 of City's Campaign and Governmental Conduct Code, and Section 87100 et seq. and Section 1090 et seq. of the Government Code of the State of California, and certifies that it does not know of any facts which would constitute a violation of said provisions, and agrees that if Tenant becomes aware of any such fact during the term of this Lease Tenant shall immediately notify the City.

27.32 Charter Provisions

This Lease is governed by and subject to the provisions of the Charter of the City and County of San Francisco.

27.33 Drug-Free Workplace

Tenant acknowledges that pursuant to the Federal Drug-Free Workplace Act of 1989, the unlawful manufacture, distribution, possession or use of a controlled substance is prohibited on City premises. Tenant agrees that any violation of this prohibition by Tenant, its Agents or assigns shall be deemed a material breach of this Lease.

27.34 Prohibition of Tobacco Sales and Advertising

Tenant acknowledges and agrees that no advertising or sale of cigarettes or tobacco products is allowed on the Premises. This advertising prohibition includes the placement of the name of a company producing cigarettes or tobacco products or the name of any cigarette or tobacco product in any promotion of any event or product.

27.35 Counterparts

This Lease may be executed in two or more counterparts, each of which shall be deemed an original, but all of which taken together shall constitute one and the same instrument.

27.36 Effective Date

This Lease shall become effective on the date upon which this Lease is duly executed and delivered by the parties hereto.

27.37 Acceptance of Lease by Tenant

This Lease shall be null and void unless Tenant accepts it and returns to City three (3) fully executed counterparts hereof on or before 5:00 p.m. San Francisco Time on June 15, 2018.

27.38 Requiring Health Benefits for Covered Employees

Unless exempt, Tenant agrees to comply fully with and be bound by all of the provisions of the Health Care Accountability Ordinance (HCAO), as set forth in San Francisco Administrative Code Chapter 12Q, including the remedies provided, and implementing regulations, as the same may be amended from time to time. The provisions of Chapter 12Q are

incorporated herein by reference and made a part of this Lease as though fully set forth. The text of the HCAO is available on the web at <http://www.sfgov.org/olse/hcao>. Capitalized terms used in this Section and not defined in this Lease shall have the meanings assigned to such terms in Chapter 12Q.

(a) For each Covered Employee, Tenant shall provide the appropriate health benefit set forth in Section 12Q.3 of the HCAO. If Tenant chooses to offer the health plan option, such health plan shall meet the minimum standards set forth by the San Francisco Health Commission.

(b) Notwithstanding the above, if the Tenant is a small business as defined in Section 12Q.3(d) of the HCAO, it shall have no obligation to comply with subsection (a) above.

(c) Tenant's failure to comply with the HCAO shall constitute a material breach of this Lease. City shall notify Tenant if such a breach has occurred. If, within thirty (30) days after receiving City's written notice of a breach of this Lease for violating the HCAO, Tenant fails to cure such breach or, if such breach cannot reasonably be cured within such period of thirty (30) days, Tenant fails to commence efforts to cure within such period, or thereafter fails diligently to pursue such cure to completion, City shall have the right to pursue the remedies set forth in Section 12Q.5(f)(1-5). Each of these remedies shall be exercisable individually or in combination with any other rights or remedies available to City.

(d) Any Subcontract entered into by Tenant shall require the Subcontractor to comply with the requirements of the HCAO and shall contain contractual obligations substantially the same as those set forth in this Section. Tenant shall notify City's Purchasing Department when it enters into such a Subcontract and shall certify to the Purchasing Department that it has notified the Subcontractor of the obligations under the HCAO and has imposed the requirements of the HCAO on Subcontractor through the Subcontract. Each Tenant shall be responsible for its Subcontractors' compliance with this Chapter. If a Subcontractor fails to comply, the City may pursue the remedies set forth in this Section against Tenant based on the Subcontractor's failure to comply, provided that City has first provided Tenant with notice and an opportunity to obtain a cure of the violation.

(e) Tenant shall not discharge, reduce in compensation, or otherwise discriminate against any employee for notifying City with regard to Tenant's compliance or anticipated compliance with the requirements of the HCAO, for opposing any practice proscribed by the HCAO, for participating in proceedings related to the HCAO, or for seeking to assert or enforce any rights under the HCAO by any lawful means.

(f) Tenant represents and warrants that it is not an entity that was set up, or is being used, for the purpose of evading the intent of the HCAO.

(g) Tenant shall keep itself informed of the current requirements of the HCAO.

(h) Tenant shall provide reports to the City in accordance with any reporting standards promulgated by the City under the HCAO, including reports on Subcontractors and Subtenants, as applicable.

(i) Tenant shall provide City with access to records pertaining to compliance with HCAO after receiving a written request from City to do so and being provided at least five (5) business days to respond.

(j) City may conduct random audits of Tenant to ascertain its compliance with HCAO. Tenant agrees to cooperate with City when it conducts such audits.

(k) If Tenant is exempt from the HCAO when this Lease is executed because its amount is less than Fifty Thousand Dollars (\$50,000), but Tenant later enters into an agreement or agreements that cause Tenant's aggregate amount of all agreements with City to reach Seventy-Five Thousand Dollars (\$75,000), all the agreements shall be thereafter subject to the HCAO. This obligation arises on the effective date of the agreement that causes the cumulative amount of agreements between Tenant and the Contracting Department to be equal to or greater than Seventy-Five Thousand Dollars (\$75,000) in the fiscal year.

27.39 Notification of Limitations on Contributions

Through its execution of this Lease, Tenant acknowledges that it is familiar with Section 1.126 of the San Francisco Campaign and Governmental Conduct Code, which prohibits any person who contracts with the City for the selling or leasing of any land or building to or from the City whenever such transaction would require approval by a City elective officer, the board on which that City elective officer serves, or a board on which an appointee of that individual serves, from making any campaign contribution to (a) the City elective officer, (b) a candidate for the office held by such individual, or (c) a committee controlled by such individual or candidate, at any time from the commencement of negotiations for the contract until the later of either the termination of negotiations for such contract or six months after the date the contract is approved. Tenant acknowledges that the foregoing restriction applies only if the contract or a combination or series of contracts approved by the same individual or board in a fiscal year have a total anticipated or actual value of \$50,000 or more. Tenant further acknowledges that the prohibition on contributions applies to each Tenant; each member of Tenant's board of directors, and Tenant's chief executive officer, chief financial officer and chief operating officer; any person with an ownership interest of more than twenty percent (20%) in Tenant; any subcontractor listed in the contract; and any committee that is sponsored or controlled by Tenant. Additionally, Tenant acknowledges that Tenant must inform each of the persons described in the preceding sentence of the prohibitions contained in Section 1.126. Tenant further agrees to provide to City the name of each person, entity or committee described above.

27.40 Preservative-Treated Wood Containing Arsenic

Tenant may not purchase preservative-treated wood products containing arsenic in the performance of this Lease unless an exemption from the requirements of Environment Code Chapter 13 is obtained from the Department of Environment under Section 1304 of the Environment Code. The term "preservative-treated wood containing arsenic" shall mean wood treated with a preservative that contains arsenic, elemental arsenic, or an arsenic copper combination, including, but not limited to, chromated copper arsenate preservative, ammoniac copper zinc arsenate preservative, or ammoniacal copper arsenate preservative. Tenant may purchase preservative-treated wood products on the list of environmentally preferable alternatives prepared and adopted by the Department of Environment. This provision does not preclude Tenant from purchasing preservative-treated wood containing arsenic for saltwater immersion. The term "saltwater immersion" shall mean a pressure-treated wood that is used for construction purposes or facilities that are partially or totally immersed in saltwater.

27.41 Resource-Efficient City Buildings

Tenant acknowledges that the City and County of San Francisco has enacted San Francisco Environment Code Sections 700 to 713 relating to green building requirements for the design, construction, and operation of buildings owned or leased by City. Tenant hereby agrees that it shall comply with all applicable provisions of such code sections.

26.42 Food Service and Packaging Waste Reduction Ordinance

All undefined, initially-capitalized terms used in this Section shall have the meanings given to them in Chapter 15 of the San Francisco Environment Code (the "Food Service and Packaging Waste Reduction Ordinance"), which among other things, prohibits the provision of Prepared Food in Food Service Ware made, in whole or part, from Polystyrene Foam or in Food Service Ware that is not Compostable or Recyclable. Tenant agrees to comply fully with and be bound by all of the provisions of the Food Service and Packaging Waste Reduction Ordinance, including the remedies provided therein, and implementing guidelines and rules. The provisions of Chapter 16 are incorporated herein by reference and made a part of this Lease as though fully set forth herein. This provision is a material term of this Lease. By entering into this Lease, Tenant agrees that if it breaches this provision, City will suffer actual damages that will be impractical or extremely difficult to determine. Without limiting City's other rights and remedies, Tenant agrees that the sum of One Hundred Dollars (\$100.00) liquidated damages for the first breach, Two Hundred Dollars (\$200.00) liquidated damages for the second breach in the same year, and Five Hundred Dollars (\$500.00) liquidated damages for subsequent breaches in the same year is a reasonable estimate of the damage that City will incur based on the violation, established in light of the circumstances existing at the time this Lease was made. Such amounts shall not be considered a penalty, but rather agreed monetary damages sustained by City because of Tenant's failure to comply with this provision.

26.43 San Francisco Packaged Water Ordinance

Tenant agrees to comply with San Francisco Environment Code Chapter 24 ("Chapter 24"). Tenant shall not sell, provide or otherwise distribute Packaged Water, as defined in Chapter 24 (including bottled water), in the performance of this Agreement or on City property unless Tenant obtains a waiver from the City's Department of the Environment. If Tenant violates this requirement, the City may exercise all remedies in this Agreement and the Director of the City's Department of the Environment may impose administrative fines as set forth in Chapter 24.

27.44 Criminal History in Hiring and Employment Decisions

(a) Unless exempt, Tenant agrees to comply with and be bound by all of the provisions of San Francisco Administrative Code Chapter 12T (Criminal History in Hiring and Employment Decisions; "Chapter 12 T"), which are hereby incorporated as may be amended from time to time, with respect to applicants and employees of Tenant who would be or are performing work at the Premises.

(b) Tenant shall incorporate by reference the provisions of Chapter 12T in all subleases of some or all of the Premises, and shall require all subtenants to comply with such provisions. Tenant's failure to comply with the obligations in this subsection shall constitute a material breach of this Lease.

(c) Tenant and subtenants shall not inquire about, require disclosure of, or if such information is received base an Adverse Action on an applicant's or potential applicant for employment, or employee's: (1) Arrest not leading to a Conviction, unless the Arrest is undergoing an active pending criminal investigation or trial that has not yet been resolved; (2) participation in or completion of a diversion or a deferral of judgment program; (3) a Conviction that has been judicially dismissed, expunged, voided, invalidated, or otherwise rendered inoperative; (4) a Conviction or any other adjudication in the juvenile justice system; (5) a Conviction that is more than seven years old, from the date of sentencing; or (6) information pertaining to an offense other than a felony or misdemeanor, such as an infraction.

(d) Tenant and subtenants shall not inquire about or require applicants, potential applicants for employment, or employees to disclose on any employment application

the facts or details of any conviction history, unresolved arrest, or any matter identified in subsection (c) above. Tenant and subtenants shall not require such disclosure or make such inquiry until either after the first live interview with the person, or after a conditional offer of employment.

(e) Tenant and subtenants shall state in all solicitations or advertisements for employees that are reasonably likely to reach persons who are reasonably likely to seek employment with Tenant or subtenant at the Premises, that the Tenant or subtenant will consider for employment qualified applicants with criminal histories in a manner consistent with the requirements of Chapter 12T.

(f) Tenant and subtenants shall post the notice prepared by the Office of Labor Standards Enforcement ("OLSE"), available on OLSE's website, in a conspicuous place at the Premises and at other workplaces within San Francisco where interviews for job opportunities at the Premises occur. The notice shall be posted in English, Spanish, Chinese, and any language spoken by at least 5% of the employees at the Premises or other workplace at which it is posted.

(g) Tenant and subtenants understand and agree that upon any failure to comply with the requirements of Chapter 12T, the City shall have the right to pursue any rights or remedies available under Chapter 12T or this Lease, including but not limited to a penalty of \$50 for a second violation and \$100 for a subsequent violation for each employee, applicant or other person as to whom a violation occurred or continued, termination or suspension in whole or in part of this Lease.

(h) If Tenant has any questions about the applicability of Chapter 12T, it may contact the City's Real Estate Division for additional information. City's Real Estate Division may consult with the Director of the City's Office of Contract Administration who may also grant a waiver, as set forth in Section 12T.8.

27.45 Cooperative Drafting

This Lease has been drafted through a cooperative effort of both parties, and both parties have had an opportunity to have the Lease reviewed and revised by legal counsel. No party shall be considered the drafter of this Lease, and no presumption or rule that an ambiguity shall be construed against the party drafting the clause shall apply to the interpretation or enforcement of this Lease.

27.46 Vending Machines; Nutritional Standards

Tenant shall not install or permit any vending machine on the Premises without the prior written consent of the Director of Property. Any permitted vending machine must comply with the food nutritional and calorie labeling requirements set forth in San Francisco Administrative Code section 4.9-1(c), as may be amended from time to time (the "Nutritional Standards Requirements"). Tenant agrees to incorporate the Nutritional Standards Requirements into any contract for the installation of a vending machine on the Premises or for the supply of food and beverages to that vending machine. Failure to comply with the Nutritional Standards Requirements or to otherwise comply with this Section shall be deemed a material breach of this Lease. Without limiting Landlord's other rights and remedies under this Lease, Landlord shall have the right to require the immediate removal of any vending machine on the Premises that is not permitted or that violates the Nutritional Standards Requirements. In addition, any restaurant located on the Premises is encouraged to ensure that at least 25% of Meals offered on the menu meet the nutritional standards set forth in San Francisco Administrative Code section 4.9-1(e), as may be amended.

27.47 All-Gender Toilet Facilities

If applicable, Tenant shall comply with San Francisco Administrative Code Section 4.1-3 requiring at least one all-gender toilet facility on each floor of any new building on City-owned land and within existing buildings leased by the City where extensive renovations are made. An "all-gender toilet facility" means a toilet that is not restricted to use by persons of a specific sex or gender identity by means of signage, design, or the installation of fixtures, and "extensive renovations" means any renovation where the construction cost exceeds 50% of the cost of providing the toilet facilities required by this section. If Tenant has any question about applicability or compliance, Tenant should contact City's Director of Property for guidance.

27.48 Employee Signature Authorization Ordinance

City has adopted an Employee Signature Authorization Ordinance (S.F. Admin Code Sections 23.50-23.56). That ordinance requires employers of employees in hotel or restaurant projects on public property with fifty (50) or more employees (whether full-time or part-time) to enter into a "card check" agreement with a labor union regarding the preference of employees to be represented by a labor union to act as their exclusive bargaining representative. Tenant shall comply with the requirements of such ordinance, if applicable, including, without limitation, any requirements in the ordinance with respect to its subtenants, licensees, and operators.

[REMAINDER OF PAGE INTENTIONALLY BLANK]

City and Tenant have executed this Lease as of the date first written above.

TENANT:

LA COCINA, INC.,
a California non-profit organization

By: 
Name: Leticia Landa
Its: Deputy Director
Date: 6/12/2018

By: _____
Name: _____
Its: _____
Date: _____

CITY:

CITY AND COUNTY OF SAN FRANCISCO,
a municipal corporation

By: 
Andrico Penick
Acting Director of Property
Date: 6/14/18.

APPROVED AS TO FORM:

DENNIS J. HERRERA, City Attorney

By: 
Carol Wong, Deputy City Attorney

EXHIBIT A

DEPICTION OF PREMISES

101 Hyde St. Block 0346-Lot 003A

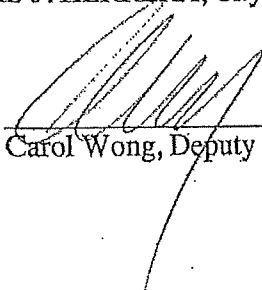
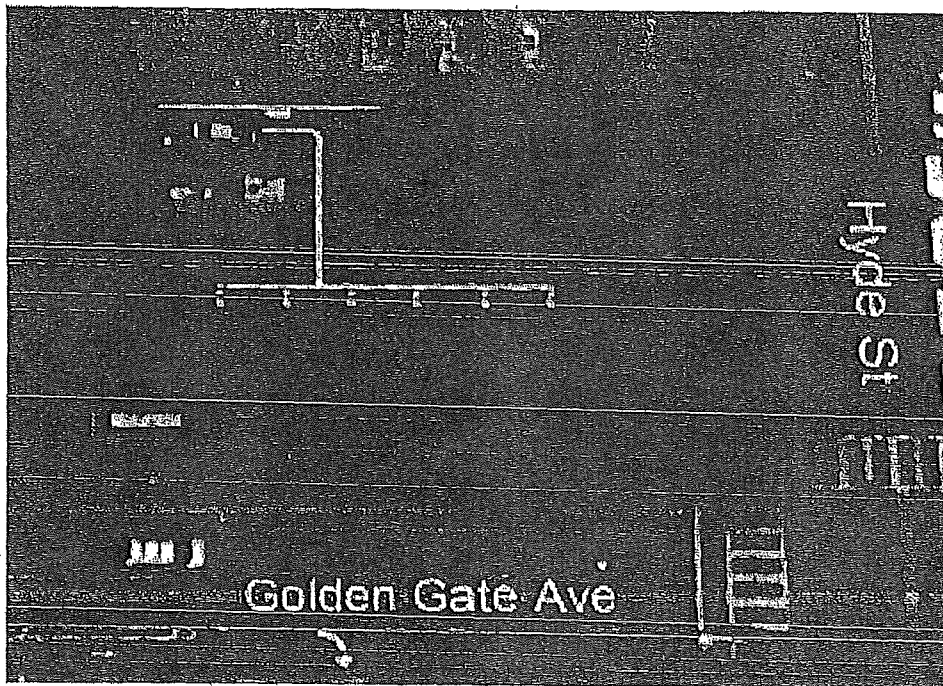
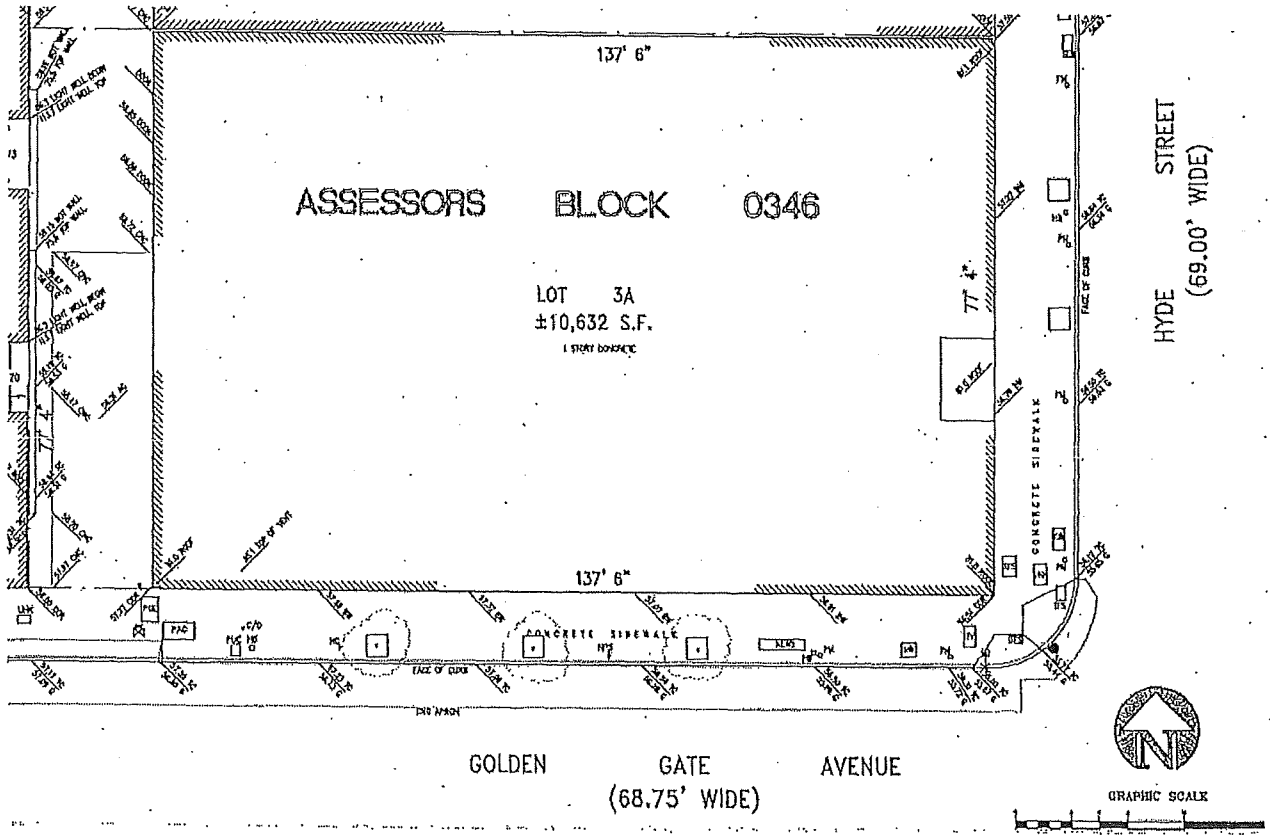

EXHIBIT B

[Intentionally Omitted]

EXHIBIT C

[Intentionally Omitted]

EXHIBIT D

NOTICE OF RENT COMMENCEMENT DATE

[Date]

Andrico Penick
Acting Director of Property
Real Estate Division
City and County of San Francisco
25 Van Ness Avenue, Suite 400
San Francisco, California 94102

RE: Acknowledgement of Rent Commencement Date and Outside Date, Lease Between La
Cocina, Inc. (Tenant), and the City and County of San Francisco (Landlord), for the
Premises located at 101 Hyde

Dear Mr. Penick:

This letter will confirm that for all purposes of the Lease, the Rent Commencement Date
(as defined in Section 3.2 of the Lease) is _____, 20__ and the Outside Date (as
defined in Section 3.2 of the Lease) is _____, 20__.

Please acknowledge your acceptance of this letter by signing and returning a copy of this
letter.

Very truly yours,

By: _____
Title: _____

Accepted and Agreed:

By: _____
Andrico Penick
Acting Director of Property
Dated: _____

EXHIBIT E

APPROVED TENANT'S PLANS AND SPECIFICATIONS

[SEE ATTACHED]

101 HYDE STREET MUNICIPAL MARKET HALL

MAY 29, 2018
PW PROJECT #000035.049

101 HYDE STREET
SAN FRANCISCO, CA 94102

ISSUE FOR PRICING SET

PERKINS
+ WILL

101 HYDE STREET
MUNICIPAL MARKET HALL
SAN FRANCISCO, CA 94102

PERKINS
+ WILL

OWNER	ARCHITECT	STRUCTURAL	CONTRACTOR	CITY OF SAN FRANCISCO
LOCAL CITY OF SAN FRANCISCO DEPARTMENT OF PUBLIC WORKS 333 CALIFORNIA STREET SAN FRANCISCO, CA 94102	PERKINS+WILL 1100 MARKET STREET SUITE 1000 SAN FRANCISCO, CA 94102	PERKINS+WILL 1100 MARKET STREET SUITE 1000 SAN FRANCISCO, CA 94102	PERKINS+WILL 1100 MARKET STREET SUITE 1000 SAN FRANCISCO, CA 94102	CITY OF SAN FRANCISCO DEPARTMENT OF PUBLIC WORKS 333 CALIFORNIA STREET SAN FRANCISCO, CA 94102

AREA PLAN MAP/PHOTOS OF ACCESSIBLE PUBLIC TRANSIT/SIDEWALK CURBS

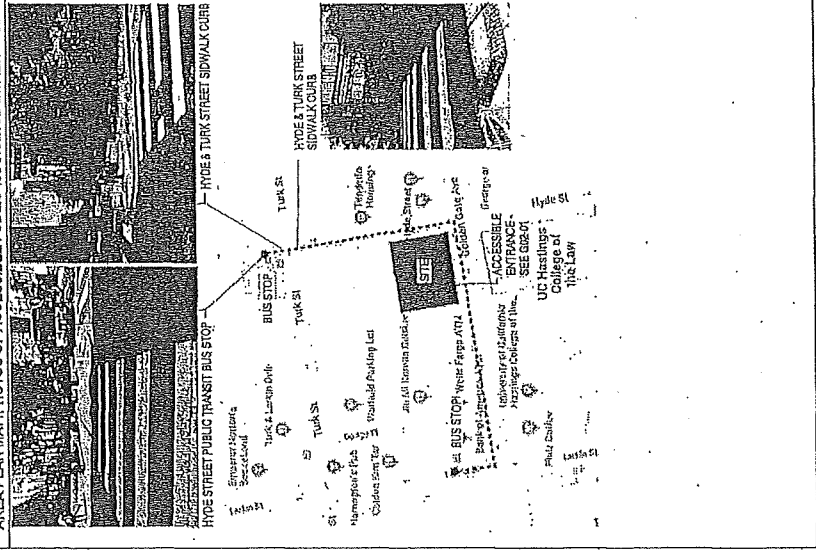

NO.	DESCRIPTION	QUANTITY	UNIT	PRICE	TOTAL
1	CONCRETE	100	YD	150.00	15000.00
2	STEEL	50	TON	200.00	10000.00
3	BRICK	200	1000	1.00	200.00
4	PAVING	500	YD	3.00	1500.00
5	ROOFING	100	SQ	10.00	1000.00
6	MECHANICAL	100	HR	10.00	1000.00
7	ELECTRICAL	100	HR	10.00	1000.00
8	PLUMBING	100	HR	10.00	1000.00
9	PAINTING	100	SQ	1.00	100.00
10	LANDSCAPING	100	HR	10.00	1000.00
11	DEMOLITION	100	HR	10.00	1000.00
12	FOUNDATION	100	YD	15.00	1500.00
13	WALLS	100	YD	10.00	1000.00
14	FLOORING	100	SQ	5.00	500.00
15	CEILING	100	SQ	5.00	500.00
16	MECHANICAL	100	HR	10.00	1000.00
17	ELECTRICAL	100	HR	10.00	1000.00
18	PLUMBING	100	HR	10.00	1000.00
19	PAINTING	100	SQ	1.00	100.00
20	LANDSCAPING	100	HR	10.00	1000.00
21	DEMOLITION	100	HR	10.00	1000.00
22	FOUNDATION	100	YD	15.00	1500.00
23	WALLS	100	YD	10.00	1000.00
24	FLOORING	100	SQ	5.00	500.00
25	CEILING	100	SQ	5.00	500.00
26	MECHANICAL	100	HR	10.00	1000.00
27	ELECTRICAL	100	HR	10.00	1000.00
28	PLUMBING	100	HR	10.00	1000.00
29	PAINTING	100	SQ	1.00	100.00
30	LANDSCAPING	100	HR	10.00	1000.00
31	DEMOLITION	100	HR	10.00	1000.00
32	FOUNDATION	100	YD	15.00	1500.00
33	WALLS	100	YD	10.00	1000.00
34	FLOORING	100	SQ	5.00	500.00
35	CEILING	100	SQ	5.00	500.00
36	MECHANICAL	100	HR	10.00	1000.00
37	ELECTRICAL	100	HR	10.00	1000.00
38	PLUMBING	100	HR	10.00	1000.00
39	PAINTING	100	SQ	1.00	100.00
40	LANDSCAPING	100	HR	10.00	1000.00
41	DEMOLITION	100	HR	10.00	1000.00
42	FOUNDATION	100	YD	15.00	1500.00
43	WALLS	100	YD	10.00	1000.00
44	FLOORING	100	SQ	5.00	500.00
45	CEILING	100	SQ	5.00	500.00
46	MECHANICAL	100	HR	10.00	1000.00
47	ELECTRICAL	100	HR	10.00	1000.00
48	PLUMBING	100	HR	10.00	1000.00
49	PAINTING	100	SQ	1.00	100.00
50	LANDSCAPING	100	HR	10.00	1000.00

DRAWING NUMBER KEY

101 HYDE STREET
MUNICIPAL MARKET HALL
SAN FRANCISCO, CA 94102

OVERALL MAP

VICINITY MAP

SITE MAP

DEFERRED SUBMITTALS

PROJECT DATA

101 HYDE STREET
MUNICIPAL MARKET HALL
SAN FRANCISCO, CA 94102

OWNER

ARCHITECT

STRUCTURAL

CONTRACTOR

CITY OF SAN FRANCISCO

PERKINS
+ WILL

101 HYDE STREET
MUNICIPAL MARKET HALL
SAN FRANCISCO, CA 94102

ISSUE FOR PRICING SET MAY 29, 2018

LA COCINA
245 CALIFORNIA STREET
SAN FRANCISCO, CA 94102

INDEX OF DRAWINGS
SHEET NUMBER
G00-01

300 CALIFORNIA STREET
SAN FRANCISCO, CA 94104
415.774.2000
WWW.PW.COM

ISSUE DATE: 05/29/18
PROJECT: 101 HYDE STREET
DRAWING: MEZZANINE - CODE COMPLIANCE PLAN
DATE: 05/29/18
DRAWN BY: J. [Name]
CHECKED BY: [Name]
APPROVED BY: [Name]

ALL WORK SHALL BE IN ACCORDANCE WITH THE 2015 CALIFORNIA MECHANICAL CODE AND THE 2015 CALIFORNIA PLUMBING CODE.

101 HYDE STREET
MUNICIPAL MARKET
HALL
300 CALIFORNIA STREET
SAN FRANCISCO, CA 94104



LA OCEANA
200 CALIFORNIA STREET
SAN FRANCISCO, CA 94104



ISSUE DATE: 05/29/18

PROJECT: 101 HYDE STREET
DRAWING: MEZZANINE - CODE COMPLIANCE PLAN
DATE: 05/29/18
DRAWN BY: J. [Name]
CHECKED BY: [Name]
APPROVED BY: [Name]

CODE COMPLIANCE PLANS
SHEET NO. 02
G01-02

**CODE COMPLIANCE PLAN
GENERAL NOTES**

1. ALL WORK SHALL BE IN ACCORDANCE WITH THE 2015 CALIFORNIA MECHANICAL CODE AND THE 2015 CALIFORNIA PLUMBING CODE.
2. ALL WORK SHALL BE IN ACCORDANCE WITH THE 2015 CALIFORNIA MECHANICAL CODE AND THE 2015 CALIFORNIA PLUMBING CODE.
3. ALL WORK SHALL BE IN ACCORDANCE WITH THE 2015 CALIFORNIA MECHANICAL CODE AND THE 2015 CALIFORNIA PLUMBING CODE.
4. ALL WORK SHALL BE IN ACCORDANCE WITH THE 2015 CALIFORNIA MECHANICAL CODE AND THE 2015 CALIFORNIA PLUMBING CODE.
5. ALL WORK SHALL BE IN ACCORDANCE WITH THE 2015 CALIFORNIA MECHANICAL CODE AND THE 2015 CALIFORNIA PLUMBING CODE.
6. ALL WORK SHALL BE IN ACCORDANCE WITH THE 2015 CALIFORNIA MECHANICAL CODE AND THE 2015 CALIFORNIA PLUMBING CODE.
7. ALL WORK SHALL BE IN ACCORDANCE WITH THE 2015 CALIFORNIA MECHANICAL CODE AND THE 2015 CALIFORNIA PLUMBING CODE.

**CODE COMPLIANCE PLAN
LEGEND**

MECHANICAL
PLUMBING
ELECTRICAL
FIRE PROTECTION
STRUCTURAL
GENERAL

MECHANICAL
PLUMBING
ELECTRICAL
FIRE PROTECTION
STRUCTURAL
GENERAL

MECHANICAL
PLUMBING
ELECTRICAL
FIRE PROTECTION
STRUCTURAL
GENERAL

**OCCUPANT LOAD FOR
LEVEL 01 & MEZZANINE**

OCCUPANT LOAD LEGEND

OFFICE
RETAIL
RESTAURANT
THEATER
GYMNASIUM
ASSEMBLY
COURT
LABORATORY
WORKSHOP
CLASSROOM
SCHOOL
UNIVERSITY
HOSPITAL
HOTEL
MUSEUM
GALLERY
LIBRARY
MUSEUM
GALLERY
LIBRARY

AREA	AREA (SQ FT)	OCCUPANT LOAD
MEZZANINE	1,200	120
LEVEL 01	10,000	1,000
TOTAL	11,200	1,120

**CODE COMPLIANCE PLAN
NOTES BY NUMBER**

1. ALL WORK SHALL BE IN ACCORDANCE WITH THE 2015 CALIFORNIA MECHANICAL CODE AND THE 2015 CALIFORNIA PLUMBING CODE.

2. ALL WORK SHALL BE IN ACCORDANCE WITH THE 2015 CALIFORNIA MECHANICAL CODE AND THE 2015 CALIFORNIA PLUMBING CODE.

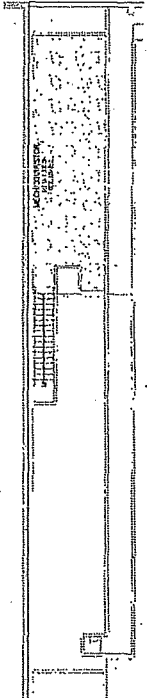

② MEZZANINE - CODE COMPLIANCE PLAN

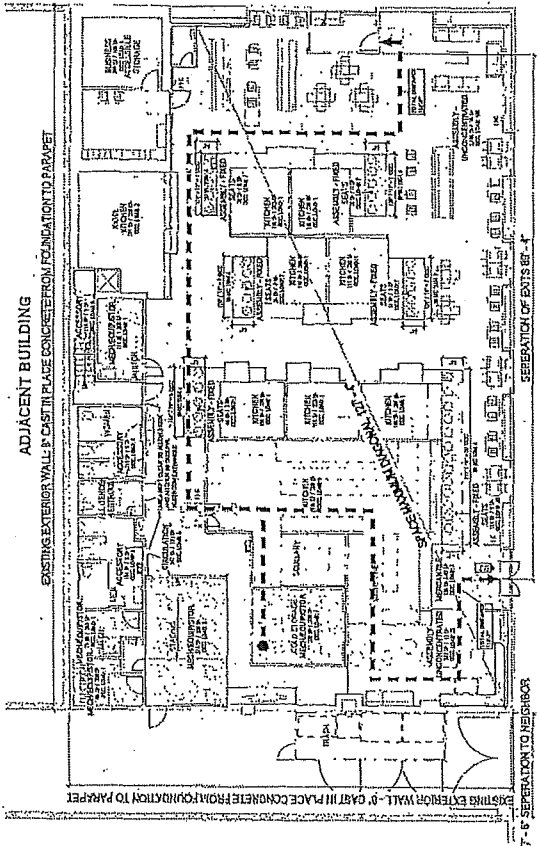

① LEVEL 01 CODE COMPLIANCE PLAN

HYDE STREET

GOLDEN GATE AVENUE

PLUMBING FEATURE CALCULATION

FEATURE	UNIT	QUANTITY	LOAD (LBS)
MECHANICAL	LB	100	100
PLUMBING	LB	200	200
ELECTRICAL	LB	50	50
STRUCTURAL	LB	100	100
TOTAL	LB	450	450

300 N. LAKE STREET
CHICAGO, IL 60601
TEL: 312.329.4200
WWW.PWILL.COM

CONSULTANTS
ARCHITECTS
INTERIORS
MECHANICAL/ELECTRICAL/PLUMBING
STRUCTURAL ENGINEERS
ENVIRONMENTAL ENGINEERS
Landscape Architecture
Acoustic Engineering
Civil Engineering
Fire Engineering
Historic Preservation
Interior Design
Lighting Design
Parks and Recreation
Public Art
Transportation Planning
Urban Planning
Visual Quality Assessment

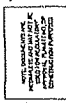

101 HYDE STREET
MUNICIPAL MARKET
101 HYDE STREET
SAN FRANCISCO, CA 94102

LA COCINA
SAN FRANCISCO, CA 94102

298 FOLSOM STREET
SAN FRANCISCO, CA 94102

ISSUE FOR PUNCH SET MAY 29, 2018

BASE DRAFT

PROJECT: 101 HYDE STREET MUNICIPAL MARKET
SHEET: ACCESSIBILITY COMPLIANCE - BASIC ELEMENTS
DATE: 05/29/18

G02-11

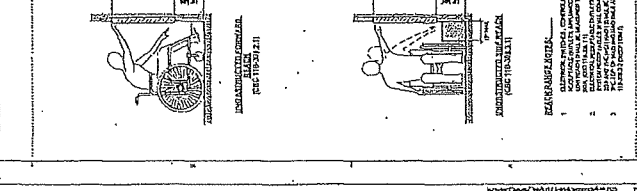
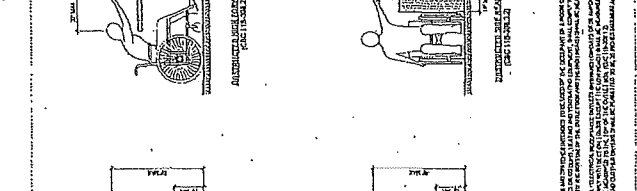
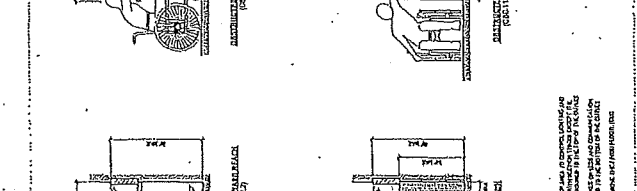
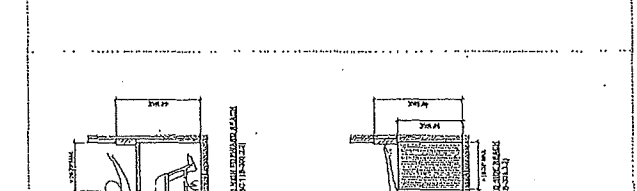
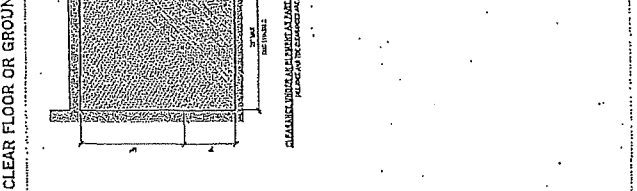
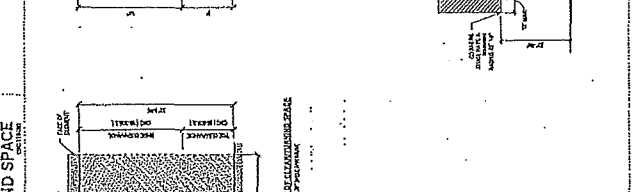
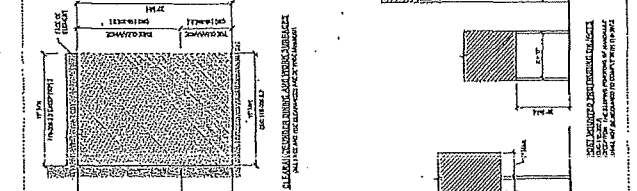
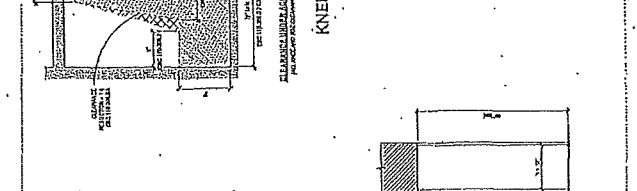
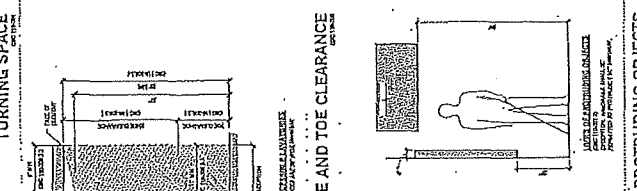
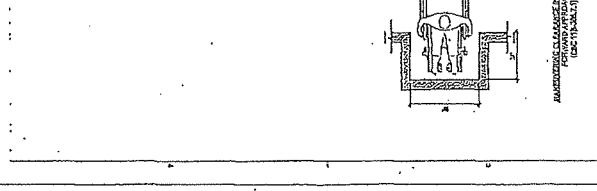
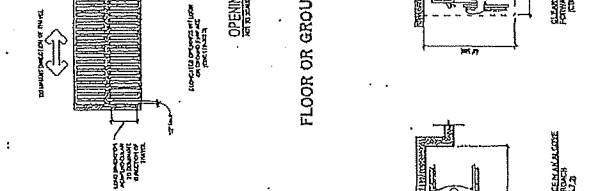
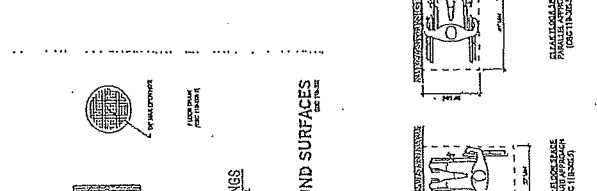
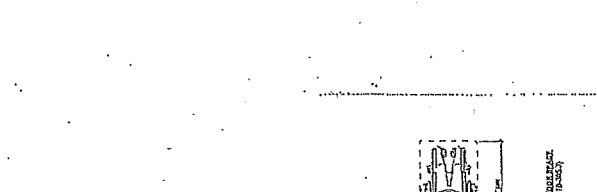
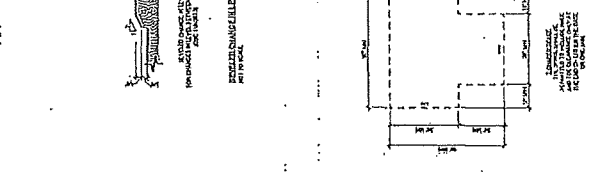
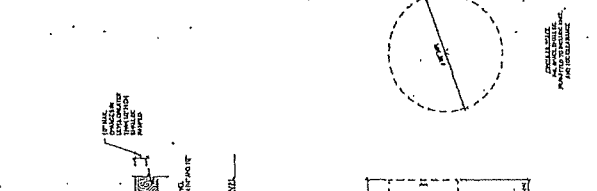
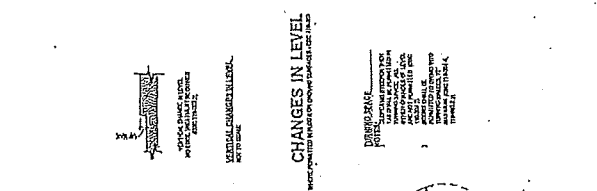

REACH RANGES
STANDING: 48 INCHES
SEATED: 48 INCHES

1. REACH RANGES: CLEARANCE FROM THE BOTTOM OF THE REACH RANGE TO THE TOP OF THE REACH RANGE SHALL BE 48 INCHES.
2. REACH RANGES: CLEARANCE FROM THE FRONT OF THE REACH RANGE TO THE BACK OF THE REACH RANGE SHALL BE 48 INCHES.
3. REACH RANGES: CLEARANCE FROM THE SIDE OF THE REACH RANGE TO THE OTHER SIDE OF THE REACH RANGE SHALL BE 48 INCHES.

1700 Broadway
New York, NY 10019
Tel: 212 512 2000
Fax: 212 512 2001
www.perkinswill.com

CONSULTANT

1700 Broadway
New York, NY 10019
Tel: 212 512 2000
Fax: 212 512 2001
www.perkinswill.com

ARCHITECT

1700 Broadway
New York, NY 10019
Tel: 212 512 2000
Fax: 212 512 2001
www.perkinswill.com

ENGINEER

1700 Broadway
New York, NY 10019
Tel: 212 512 2000
Fax: 212 512 2001
www.perkinswill.com

MECHANICAL

1700 Broadway
New York, NY 10019
Tel: 212 512 2000
Fax: 212 512 2001
www.perkinswill.com

ELECTRICAL

1700 Broadway
New York, NY 10019
Tel: 212 512 2000
Fax: 212 512 2001
www.perkinswill.com

PLUMBING

1700 Broadway
New York, NY 10019
Tel: 212 512 2000
Fax: 212 512 2001
www.perkinswill.com

MECHANICAL

1700 Broadway
New York, NY 10019
Tel: 212 512 2000
Fax: 212 512 2001
www.perkinswill.com

ELECTRICAL

1700 Broadway
New York, NY 10019
Tel: 212 512 2000
Fax: 212 512 2001
www.perkinswill.com

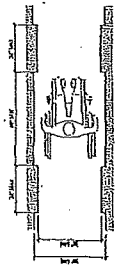

CLEAR WIDTH OF AN ACCESSIBLE ROUTE

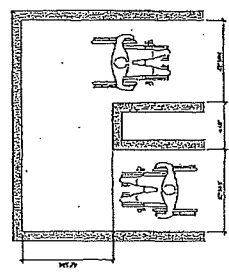

CLEAR WIDTH AT TURN

- CLEAR WIDTH**
1. CLEAR WIDTH SHALL BE MEASURED AS SHOWN IN THE DIAGRAM.
 2. CLEAR WIDTH SHALL BE MEASURED FROM THE CENTERLINE OF THE ROUTE TO THE CENTERLINE OF THE ROUTE.
 3. CLEAR WIDTH SHALL BE MEASURED FROM THE CENTERLINE OF THE ROUTE TO THE CENTERLINE OF THE ROUTE.
 4. CLEAR WIDTH SHALL BE MEASURED FROM THE CENTERLINE OF THE ROUTE TO THE CENTERLINE OF THE ROUTE.

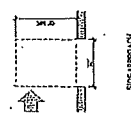

MANEUVERING CLEARANCE AT DOORWAYS WITHOUT DOORS OR GATES

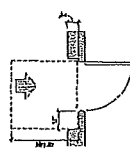

CLEARANCE AT RECESSED DOORS

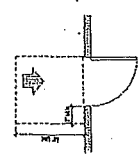

FRONT APPROACH WITH GLASS AND LATCH

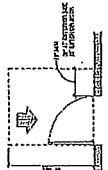

FRONT APPROACH WITH PULL CASE

MANEUVERING CLEARANCE AT ACCESSIBLE DOORS AND GATES

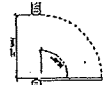

RECESSED DOOR

- CLEARANCE AT RECESSED DOORS**
1. CLEARANCE SHALL BE MEASURED AS SHOWN IN THE DIAGRAM.
 2. CLEARANCE SHALL BE MEASURED FROM THE CENTERLINE OF THE ROUTE TO THE CENTERLINE OF THE ROUTE.
 3. CLEARANCE SHALL BE MEASURED FROM THE CENTERLINE OF THE ROUTE TO THE CENTERLINE OF THE ROUTE.
 4. CLEARANCE SHALL BE MEASURED FROM THE CENTERLINE OF THE ROUTE TO THE CENTERLINE OF THE ROUTE.

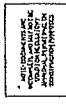

101 HYDE STREET
MUNICIPAL MARKET
HALL
141 HERRING STREET
SAN FRANCISCO, CA 94102

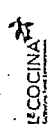

LA COCINA
2548 FOLESON STREET SAN
FRANCISCO, CA 94110

ISSUE DATE: MAY 29, 2018

NO.	DESCRIPTION	DATE
1	ISSUED FOR PERMITS	05/29/18
2	ISSUED FOR PERMITS	05/29/18
3	ISSUED FOR PERMITS	05/29/18
4	ISSUED FOR PERMITS	05/29/18
5	ISSUED FOR PERMITS	05/29/18
6	ISSUED FOR PERMITS	05/29/18
7	ISSUED FOR PERMITS	05/29/18
8	ISSUED FOR PERMITS	05/29/18
9	ISSUED FOR PERMITS	05/29/18
10	ISSUED FOR PERMITS	05/29/18

ACCESSIBILITY
COMPLIANCE
ACCESSIBLE ROUTES

SHEET NUMBER
G02-12

DATE PLOTTED: 05/29/18

100 CALIFORNIA STREET
SAN FRANCISCO, CA 94102
415.774.2000
WWW.PW.COM

ARCHITECTS
PLANNERS
ENGINEERS
INTERIORS
LANDSCAPE ARCHITECTS
ENVIRONMENTAL DESIGNERS

401 RYDE STREET
MUNICIPAL MARKET
181 RYDE STREET
SAN FRANCISCO, CA 94102

ECOCINA
LA COCINA
246 FOLSOM STREET
SAN FRANCISCO, CA 94102

DESIGNED FOR PERKINS+WILL MAY 29, 2018

PROJECT
SITE: 401 RYDE STREET
MUNICIPAL MARKET
181 RYDE STREET
SAN FRANCISCO, CA 94102

SHEET NO. 14
G02-14

SIGNAGE GENERAL NOTES

1. ALL SIGNAGE SHALL BE MANUFACTURED BY PERKINS+WILL OR AN APPROVED MANUFACTURER.
2. ALL SIGNAGE SHALL BE MANUFACTURED IN ACCORDANCE WITH THE 2018 INTERNATIONAL BUILDING CODE (IBC) AND THE 2018 INTERNATIONAL SPOKEN LANGUAGE ACCESSIBILITY STANDARDS (ISLAS).
3. ALL SIGNAGE SHALL BE MANUFACTURED IN ACCORDANCE WITH THE 2018 INTERNATIONAL SPOKEN LANGUAGE ACCESSIBILITY STANDARDS (ISLAS).
4. ALL SIGNAGE SHALL BE MANUFACTURED IN ACCORDANCE WITH THE 2018 INTERNATIONAL SPOKEN LANGUAGE ACCESSIBILITY STANDARDS (ISLAS).
5. ALL SIGNAGE SHALL BE MANUFACTURED IN ACCORDANCE WITH THE 2018 INTERNATIONAL SPOKEN LANGUAGE ACCESSIBILITY STANDARDS (ISLAS).
6. ALL SIGNAGE SHALL BE MANUFACTURED IN ACCORDANCE WITH THE 2018 INTERNATIONAL SPOKEN LANGUAGE ACCESSIBILITY STANDARDS (ISLAS).
7. ALL SIGNAGE SHALL BE MANUFACTURED IN ACCORDANCE WITH THE 2018 INTERNATIONAL SPOKEN LANGUAGE ACCESSIBILITY STANDARDS (ISLAS).
8. ALL SIGNAGE SHALL BE MANUFACTURED IN ACCORDANCE WITH THE 2018 INTERNATIONAL SPOKEN LANGUAGE ACCESSIBILITY STANDARDS (ISLAS).
9. ALL SIGNAGE SHALL BE MANUFACTURED IN ACCORDANCE WITH THE 2018 INTERNATIONAL SPOKEN LANGUAGE ACCESSIBILITY STANDARDS (ISLAS).
10. ALL SIGNAGE SHALL BE MANUFACTURED IN ACCORDANCE WITH THE 2018 INTERNATIONAL SPOKEN LANGUAGE ACCESSIBILITY STANDARDS (ISLAS).

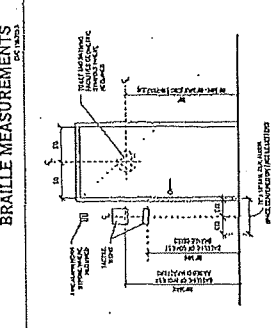
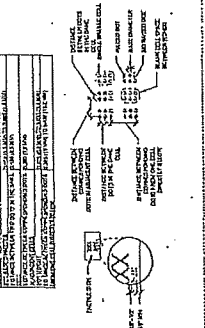
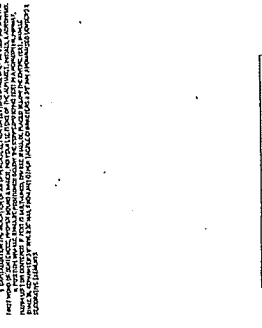

SIGNAGE MOUNTING LOCATIONS

WALL MOUNTING: Signs shall be mounted on a wall or partition at least 48 inches high from the floor to the top of the sign.

POLE MOUNTING: Signs shall be mounted on a pole at least 48 inches high from the floor to the top of the sign.

CEILING MOUNTING: Signs shall be mounted on the ceiling at least 48 inches from the floor to the bottom of the sign.

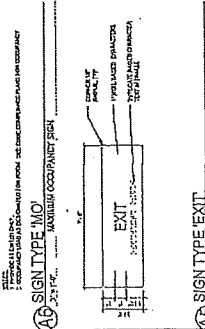
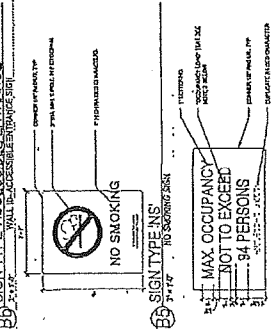
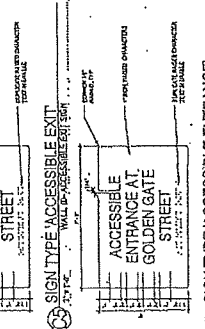
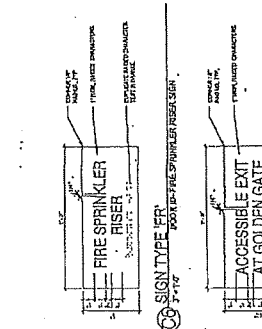
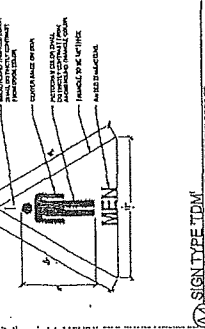
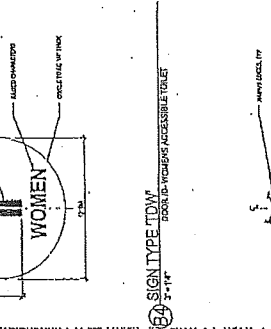
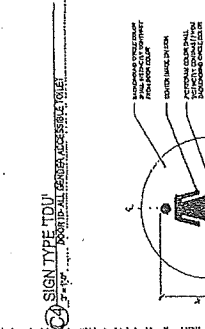
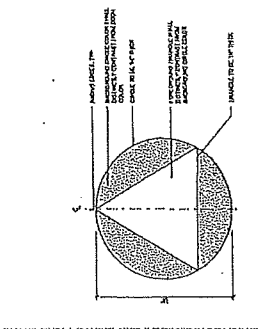
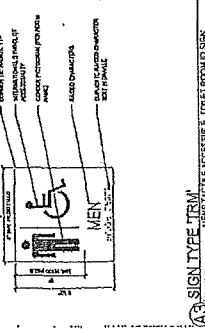
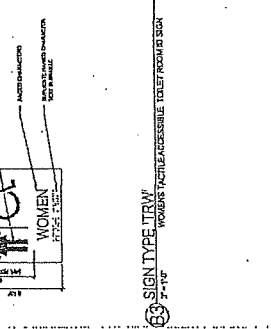
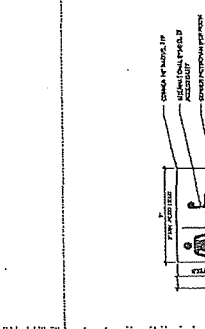
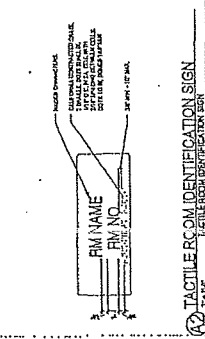
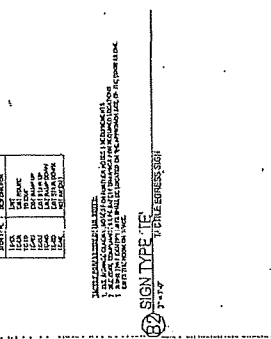
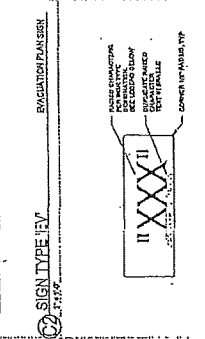
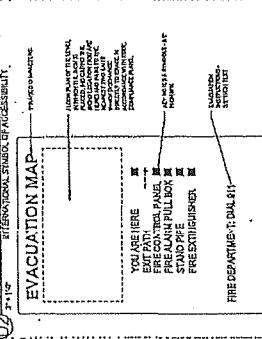
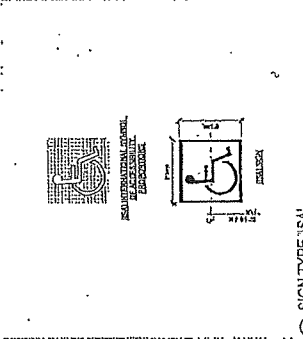

100 Montgomery Street
San Francisco, CA 94104
Tel: 415.774.2000
www.perkinswill.com

CONSULTANTS
ARCHITECT: PERKINS+WILL
MECHANICAL: PERKINS+WILL
ELECTRICAL: PERKINS+WILL
PLUMBING: PERKINS+WILL
STRUCTURAL: PERKINS+WILL
INTERIOR DESIGN: PERKINS+WILL
LANDSCAPE ARCHITECTURE: PERKINS+WILL
ENVIRONMENTAL DESIGN: PERKINS+WILL
GENERAL CONTRACTOR: PERKINS+WILL

SEE SECTION A1
FOR DETAILS OF
ACCESSIBLE
ELEVATOR

PROJECT

101 HYDE STREET
MUNICIPAL MARKET
HALL
101 HYDE STREET
SAN FRANCISCO, CA 94102

LEOCINA
L.J. COCINA
200 FOLSOM STREET SAN
FRANCISCO, CA 94102
RETIRED

DATE CHART

DATE	DESCRIPTION

**ACCESSIBILITY
COMPLIANCE
DETAILS**

SHEET NUMBER
G02-15

DATE: 05/20/10

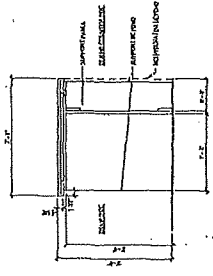

3 COUNTERTOP
2'-0\"/>



2 HANDRAIL CROSS SECTIONS
2'-0\"/>

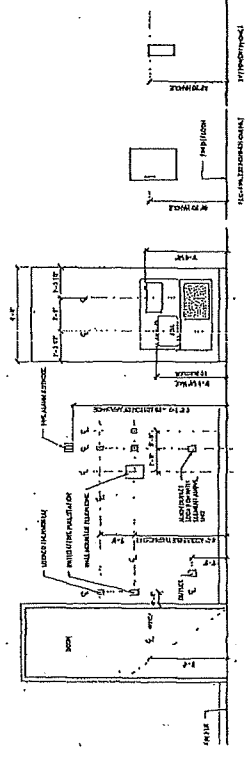

1 TYPICAL MOUNTING HEIGHTS
2'-0\"/>

SEE SECTION A1
FOR DETAILS OF
ACCESSIBLE
ELEVATOR

300 North LaSalle Street
Chicago, IL 60610
Tel: 312.420.4200
www.perkinswill.com

CONSULTANTS:
ARCHITECT: PERKINS+WILL
STRUCTURAL: HOK
MECHANICAL/ELECTRICAL/PLUMBING: HOK
ENVIRONMENTAL: HOK
LANDSCAPE ARCHITECTURE: HOK
INTERIOR ARCHITECTURE: HOK
GENERAL CONTRACTOR: HOK

PROJECT:
101 FRODO STREET
MUNICIPAL MARKET
101 FRODO STREET
SAN FRANCISCO, CA 94102

LA CUCINA
254 FOLSOM STREET SAN FRANCISCO, CA 94102

ISSUE FOR PHOENIX SET MAY 29, 2018

DATE: 05/29/18

PROJECT: 101 FRODO STREET

101 FRODO STREET

LA CUCINA

254 FOLSOM STREET SAN FRANCISCO, CA 94102

DATE: 05/29/18

PROJECT: 101 FRODO STREET

101 FRODO STREET

LA CUCINA

254 FOLSOM STREET SAN FRANCISCO, CA 94102

DATE: 05/29/18

PROJECT: 101 FRODO STREET

101 FRODO STREET

LA CUCINA

254 FOLSOM STREET SAN FRANCISCO, CA 94102

DATE: 05/29/18

PROJECT: 101 FRODO STREET

DEMO PLAN LEGEND

SYMBOL	DESCRIPTION
(Symbol)	DEMOLITION - EXISTING
(Symbol)	DEMOLITION - PROPOSED
(Symbol)	DEMOLITION - EXISTING (NOT TO BE DEMOLISHED)
(Symbol)	DEMOLITION - PROPOSED (NOT TO BE DEMOLISHED)

DEMOLITION NOTES BY NUMBER

NOTE NUMBER	DESCRIPTION
01	REMOVE EXISTING CONCRETE FLOOR SLAB AND REINFORCING BARS.
02	REMOVE EXISTING CONCRETE WALLS AND REINFORCING BARS.
03	REMOVE EXISTING CONCRETE CEILING AND REINFORCING BARS.
04	REMOVE EXISTING MECHANICAL ROOMS AND REINFORCING BARS.
05	REMOVE EXISTING STAIRS AND REINFORCING BARS.
06	REMOVE EXISTING ELEVATOR SHAFTS AND REINFORCING BARS.
07	REMOVE EXISTING CORE WALLS AND REINFORCING BARS.
08	REMOVE EXISTING CORE WALLS AND REINFORCING BARS.
09	REMOVE EXISTING CORE WALLS AND REINFORCING BARS.
10	REMOVE EXISTING CORE WALLS AND REINFORCING BARS.
11	REMOVE EXISTING CORE WALLS AND REINFORCING BARS.
12	REMOVE EXISTING CORE WALLS AND REINFORCING BARS.
13	REMOVE EXISTING CORE WALLS AND REINFORCING BARS.
14	REMOVE EXISTING CORE WALLS AND REINFORCING BARS.
15	REMOVE EXISTING CORE WALLS AND REINFORCING BARS.
16	REMOVE EXISTING CORE WALLS AND REINFORCING BARS.
17	REMOVE EXISTING CORE WALLS AND REINFORCING BARS.
18	REMOVE EXISTING CORE WALLS AND REINFORCING BARS.
19	REMOVE EXISTING CORE WALLS AND REINFORCING BARS.
20	REMOVE EXISTING CORE WALLS AND REINFORCING BARS.
21	REMOVE EXISTING CORE WALLS AND REINFORCING BARS.
22	REMOVE EXISTING CORE WALLS AND REINFORCING BARS.
23	REMOVE EXISTING CORE WALLS AND REINFORCING BARS.
24	REMOVE EXISTING CORE WALLS AND REINFORCING BARS.
25	REMOVE EXISTING CORE WALLS AND REINFORCING BARS.
26	REMOVE EXISTING CORE WALLS AND REINFORCING BARS.
27	REMOVE EXISTING CORE WALLS AND REINFORCING BARS.
28	REMOVE EXISTING CORE WALLS AND REINFORCING BARS.
29	REMOVE EXISTING CORE WALLS AND REINFORCING BARS.
30	REMOVE EXISTING CORE WALLS AND REINFORCING BARS.
31	REMOVE EXISTING CORE WALLS AND REINFORCING BARS.
32	REMOVE EXISTING CORE WALLS AND REINFORCING BARS.
33	REMOVE EXISTING CORE WALLS AND REINFORCING BARS.
34	REMOVE EXISTING CORE WALLS AND REINFORCING BARS.
35	REMOVE EXISTING CORE WALLS AND REINFORCING BARS.
36	REMOVE EXISTING CORE WALLS AND REINFORCING BARS.
37	REMOVE EXISTING CORE WALLS AND REINFORCING BARS.
38	REMOVE EXISTING CORE WALLS AND REINFORCING BARS.
39	REMOVE EXISTING CORE WALLS AND REINFORCING BARS.
40	REMOVE EXISTING CORE WALLS AND REINFORCING BARS.
41	REMOVE EXISTING CORE WALLS AND REINFORCING BARS.
42	REMOVE EXISTING CORE WALLS AND REINFORCING BARS.
43	REMOVE EXISTING CORE WALLS AND REINFORCING BARS.
44	REMOVE EXISTING CORE WALLS AND REINFORCING BARS.
45	REMOVE EXISTING CORE WALLS AND REINFORCING BARS.
46	REMOVE EXISTING CORE WALLS AND REINFORCING BARS.
47	REMOVE EXISTING CORE WALLS AND REINFORCING BARS.
48	REMOVE EXISTING CORE WALLS AND REINFORCING BARS.
49	REMOVE EXISTING CORE WALLS AND REINFORCING BARS.
50	REMOVE EXISTING CORE WALLS AND REINFORCING BARS.
51	REMOVE EXISTING CORE WALLS AND REINFORCING BARS.
52	REMOVE EXISTING CORE WALLS AND REINFORCING BARS.
53	REMOVE EXISTING CORE WALLS AND REINFORCING BARS.
54	REMOVE EXISTING CORE WALLS AND REINFORCING BARS.
55	REMOVE EXISTING CORE WALLS AND REINFORCING BARS.
56	REMOVE EXISTING CORE WALLS AND REINFORCING BARS.
57	REMOVE EXISTING CORE WALLS AND REINFORCING BARS.
58	REMOVE EXISTING CORE WALLS AND REINFORCING BARS.
59	REMOVE EXISTING CORE WALLS AND REINFORCING BARS.
60	REMOVE EXISTING CORE WALLS AND REINFORCING BARS.
61	REMOVE EXISTING CORE WALLS AND REINFORCING BARS.
62	REMOVE EXISTING CORE WALLS AND REINFORCING BARS.
63	REMOVE EXISTING CORE WALLS AND REINFORCING BARS.
64	REMOVE EXISTING CORE WALLS AND REINFORCING BARS.
65	REMOVE EXISTING CORE WALLS AND REINFORCING BARS.
66	REMOVE EXISTING CORE WALLS AND REINFORCING BARS.
67	REMOVE EXISTING CORE WALLS AND REINFORCING BARS.
68	REMOVE EXISTING CORE WALLS AND REINFORCING BARS.
69	REMOVE EXISTING CORE WALLS AND REINFORCING BARS.
70	REMOVE EXISTING CORE WALLS AND REINFORCING BARS.
71	REMOVE EXISTING CORE WALLS AND REINFORCING BARS.
72	REMOVE EXISTING CORE WALLS AND REINFORCING BARS.
73	REMOVE EXISTING CORE WALLS AND REINFORCING BARS.
74	REMOVE EXISTING CORE WALLS AND REINFORCING BARS.
75	REMOVE EXISTING CORE WALLS AND REINFORCING BARS.
76	REMOVE EXISTING CORE WALLS AND REINFORCING BARS.
77	REMOVE EXISTING CORE WALLS AND REINFORCING BARS.
78	REMOVE EXISTING CORE WALLS AND REINFORCING BARS.
79	REMOVE EXISTING CORE WALLS AND REINFORCING BARS.
80	REMOVE EXISTING CORE WALLS AND REINFORCING BARS.
81	REMOVE EXISTING CORE WALLS AND REINFORCING BARS.
82	REMOVE EXISTING CORE WALLS AND REINFORCING BARS.
83	REMOVE EXISTING CORE WALLS AND REINFORCING BARS.
84	REMOVE EXISTING CORE WALLS AND REINFORCING BARS.
85	REMOVE EXISTING CORE WALLS AND REINFORCING BARS.
86	REMOVE EXISTING CORE WALLS AND REINFORCING BARS.
87	REMOVE EXISTING CORE WALLS AND REINFORCING BARS.
88	REMOVE EXISTING CORE WALLS AND REINFORCING BARS.
89	REMOVE EXISTING CORE WALLS AND REINFORCING BARS.
90	REMOVE EXISTING CORE WALLS AND REINFORCING BARS.
91	REMOVE EXISTING CORE WALLS AND REINFORCING BARS.
92	REMOVE EXISTING CORE WALLS AND REINFORCING BARS.
93	REMOVE EXISTING CORE WALLS AND REINFORCING BARS.
94	REMOVE EXISTING CORE WALLS AND REINFORCING BARS.
95	REMOVE EXISTING CORE WALLS AND REINFORCING BARS.
96	REMOVE EXISTING CORE WALLS AND REINFORCING BARS.
97	REMOVE EXISTING CORE WALLS AND REINFORCING BARS.
98	REMOVE EXISTING CORE WALLS AND REINFORCING BARS.
99	REMOVE EXISTING CORE WALLS AND REINFORCING BARS.
100	REMOVE EXISTING CORE WALLS AND REINFORCING BARS.

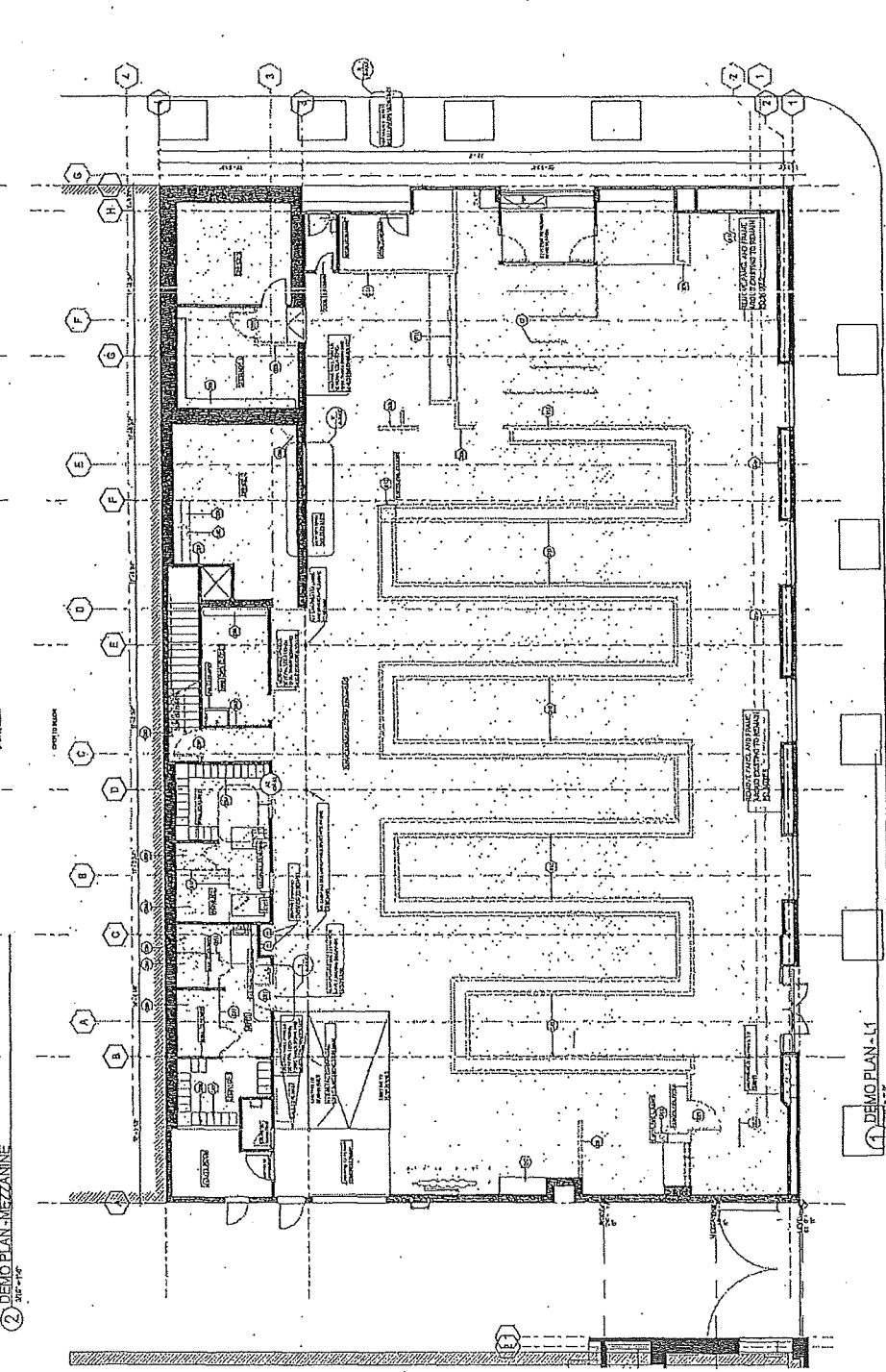

DEMO PLAN - L1

**PERKINS
+WILL**

375 CALIFORNIA STREET
SAN FRANCISCO, CA 94104
415.774.2000
WWW.PWILL.COM

ARCHITECTS
CONSULTANTS
MECHANICAL
ELECTRICAL
PLUMBING
STRUCTURAL
INTERIORS
LANDSCAPE ARCHITECTS
ENVIRONMENTAL

THIS PROJECT HAS BEEN REVIEWED BY THE ARCHITECTURAL BOARD OF THE STATE OF CALIFORNIA AND IS REGISTERED AS SUCH.

301 RIDE STREET
MUNICIPAL MARKET HALL
101 RIDE STREET
SAN FRANCISCO, CA 94102

LECCOCINA
Interior Architecture

LA COCCINA
300 CALIFORNIA STREET
SAN FRANCISCO, CA 94102
TEL: 415.774.2000



DATE CHART

NO.	DATE	DESCRIPTION	TITLE
1			
2			
3			
4			
5			

DEVIATION -
REFLECTED CEILING
PLANS
SHEET NUMBER

A04-02

DATE: 05/29/2018

DEMO RCP GENERAL NOTES

1. DEMO RCP SHALL BE DEMOLISHED AND REMOVED FROM THE PROJECT SITE. ALL DEMO RCP SHALL BE RECYCLED OR REUSED AS APPROPRIATE. DEMO RCP SHALL BE DEMOLISHED AND REMOVED FROM THE PROJECT SITE. ALL DEMO RCP SHALL BE RECYCLED OR REUSED AS APPROPRIATE.
2. ALL DEMO RCP SHALL BE DEMOLISHED AND REMOVED FROM THE PROJECT SITE. ALL DEMO RCP SHALL BE RECYCLED OR REUSED AS APPROPRIATE.
3. ALL DEMO RCP SHALL BE DEMOLISHED AND REMOVED FROM THE PROJECT SITE. ALL DEMO RCP SHALL BE RECYCLED OR REUSED AS APPROPRIATE.

DEMO RCP LEGEND

- 1. DEMO RCP LEGEND
- 2. DEMO RCP LEGEND
- 3. DEMO RCP LEGEND
- 4. DEMO RCP LEGEND
- 5. DEMO RCP LEGEND
- 6. DEMO RCP LEGEND
- 7. DEMO RCP LEGEND
- 8. DEMO RCP LEGEND
- 9. DEMO RCP LEGEND
- 10. DEMO RCP LEGEND

DEMO RCP NOTES BY NUMBER

1. DEMO RCP NOTES BY NUMBER
2. DEMO RCP NOTES BY NUMBER
3. DEMO RCP NOTES BY NUMBER
4. DEMO RCP NOTES BY NUMBER
5. DEMO RCP NOTES BY NUMBER
6. DEMO RCP NOTES BY NUMBER
7. DEMO RCP NOTES BY NUMBER
8. DEMO RCP NOTES BY NUMBER
9. DEMO RCP NOTES BY NUMBER
10. DEMO RCP NOTES BY NUMBER

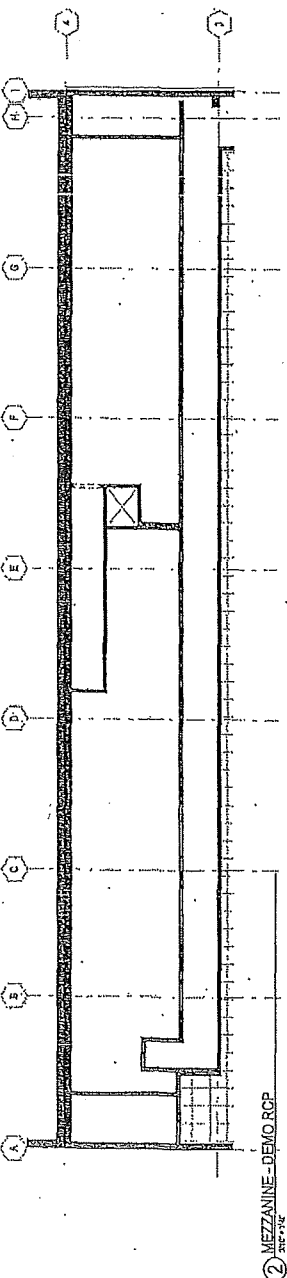

2 MEZZANINE - DEMO RCP
3/17/18

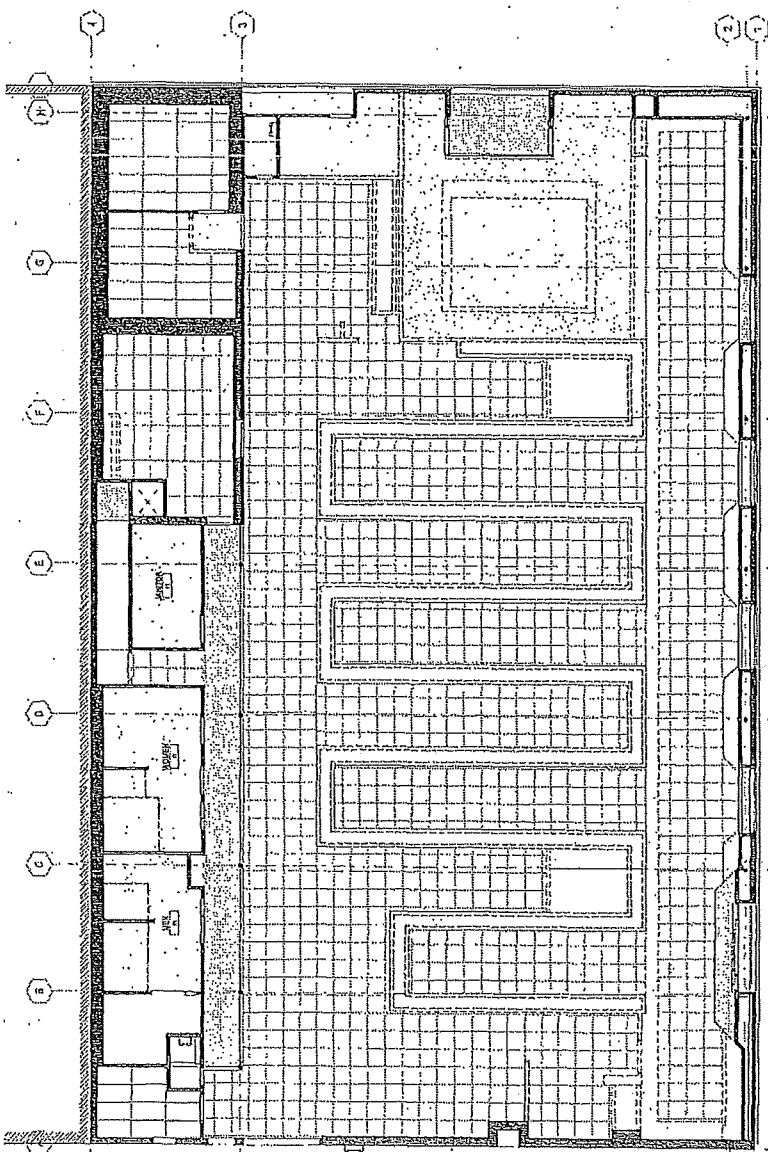

1 LEVEL 01 - DEMO RCP
3/17/18

400 CALIFORNIA STREET
SAN FRANCISCO, CA 94104
TEL: 415.774.2500
WWW.PWLLP.COM

ISSUE FOR PRICING SET MAY 29, 2018



PROJECT

447 BRIDE STREET
MUNICIPAL MARKET
181 HYDE STREET
SAN FRANCISCO, CA 94102

LA COCCINA
SAN FRANCISCO, CA 94102
FRANCISCO, CA 94102
KENTUCKY

ISSUE DATE

DATE	DESCRIPTION

TITLE

DEMOLITION DETAILS

SHEET NUMBER

A044-03

DATE

DEMOLITION PLAN LEGEND

- 1. DEMOLITION
- 2. EXISTING
- 3. NEW
- 4. REPAIR
- 5. REINFORCE
- 6. REINFORCE WITH
- 7. REINFORCE WITH
- 8. REINFORCE WITH
- 9. REINFORCE WITH
- 10. REINFORCE WITH
- 11. REINFORCE WITH
- 12. REINFORCE WITH
- 13. REINFORCE WITH
- 14. REINFORCE WITH
- 15. REINFORCE WITH
- 16. REINFORCE WITH
- 17. REINFORCE WITH
- 18. REINFORCE WITH
- 19. REINFORCE WITH
- 20. REINFORCE WITH
- 21. REINFORCE WITH
- 22. REINFORCE WITH
- 23. REINFORCE WITH
- 24. REINFORCE WITH
- 25. REINFORCE WITH
- 26. REINFORCE WITH
- 27. REINFORCE WITH
- 28. REINFORCE WITH
- 29. REINFORCE WITH
- 30. REINFORCE WITH
- 31. REINFORCE WITH
- 32. REINFORCE WITH
- 33. REINFORCE WITH
- 34. REINFORCE WITH
- 35. REINFORCE WITH
- 36. REINFORCE WITH
- 37. REINFORCE WITH
- 38. REINFORCE WITH
- 39. REINFORCE WITH
- 40. REINFORCE WITH
- 41. REINFORCE WITH
- 42. REINFORCE WITH
- 43. REINFORCE WITH
- 44. REINFORCE WITH
- 45. REINFORCE WITH
- 46. REINFORCE WITH
- 47. REINFORCE WITH
- 48. REINFORCE WITH
- 49. REINFORCE WITH
- 50. REINFORCE WITH
- 51. REINFORCE WITH
- 52. REINFORCE WITH
- 53. REINFORCE WITH
- 54. REINFORCE WITH
- 55. REINFORCE WITH
- 56. REINFORCE WITH
- 57. REINFORCE WITH
- 58. REINFORCE WITH
- 59. REINFORCE WITH
- 60. REINFORCE WITH
- 61. REINFORCE WITH
- 62. REINFORCE WITH
- 63. REINFORCE WITH
- 64. REINFORCE WITH
- 65. REINFORCE WITH
- 66. REINFORCE WITH
- 67. REINFORCE WITH
- 68. REINFORCE WITH
- 69. REINFORCE WITH
- 70. REINFORCE WITH
- 71. REINFORCE WITH
- 72. REINFORCE WITH
- 73. REINFORCE WITH
- 74. REINFORCE WITH
- 75. REINFORCE WITH
- 76. REINFORCE WITH
- 77. REINFORCE WITH
- 78. REINFORCE WITH
- 79. REINFORCE WITH
- 80. REINFORCE WITH
- 81. REINFORCE WITH
- 82. REINFORCE WITH
- 83. REINFORCE WITH
- 84. REINFORCE WITH
- 85. REINFORCE WITH
- 86. REINFORCE WITH
- 87. REINFORCE WITH
- 88. REINFORCE WITH
- 89. REINFORCE WITH
- 90. REINFORCE WITH
- 91. REINFORCE WITH
- 92. REINFORCE WITH
- 93. REINFORCE WITH
- 94. REINFORCE WITH
- 95. REINFORCE WITH
- 96. REINFORCE WITH
- 97. REINFORCE WITH
- 98. REINFORCE WITH
- 99. REINFORCE WITH
- 100. REINFORCE WITH

DEMOLITION NOTES BY NUMBER

1. DEMOLITION
2. EXISTING
3. NEW
4. REPAIR
5. REINFORCE
6. REINFORCE WITH
7. REINFORCE WITH
8. REINFORCE WITH
9. REINFORCE WITH
10. REINFORCE WITH
11. REINFORCE WITH
12. REINFORCE WITH
13. REINFORCE WITH
14. REINFORCE WITH
15. REINFORCE WITH
16. REINFORCE WITH
17. REINFORCE WITH
18. REINFORCE WITH
19. REINFORCE WITH
20. REINFORCE WITH
21. REINFORCE WITH
22. REINFORCE WITH
23. REINFORCE WITH
24. REINFORCE WITH
25. REINFORCE WITH
26. REINFORCE WITH
27. REINFORCE WITH
28. REINFORCE WITH
29. REINFORCE WITH
30. REINFORCE WITH
31. REINFORCE WITH
32. REINFORCE WITH
33. REINFORCE WITH
34. REINFORCE WITH
35. REINFORCE WITH
36. REINFORCE WITH
37. REINFORCE WITH
38. REINFORCE WITH
39. REINFORCE WITH
40. REINFORCE WITH
41. REINFORCE WITH
42. REINFORCE WITH
43. REINFORCE WITH
44. REINFORCE WITH
45. REINFORCE WITH
46. REINFORCE WITH
47. REINFORCE WITH
48. REINFORCE WITH
49. REINFORCE WITH
50. REINFORCE WITH
51. REINFORCE WITH
52. REINFORCE WITH
53. REINFORCE WITH
54. REINFORCE WITH
55. REINFORCE WITH
56. REINFORCE WITH
57. REINFORCE WITH
58. REINFORCE WITH
59. REINFORCE WITH
60. REINFORCE WITH
61. REINFORCE WITH
62. REINFORCE WITH
63. REINFORCE WITH
64. REINFORCE WITH
65. REINFORCE WITH
66. REINFORCE WITH
67. REINFORCE WITH
68. REINFORCE WITH
69. REINFORCE WITH
70. REINFORCE WITH
71. REINFORCE WITH
72. REINFORCE WITH
73. REINFORCE WITH
74. REINFORCE WITH
75. REINFORCE WITH
76. REINFORCE WITH
77. REINFORCE WITH
78. REINFORCE WITH
79. REINFORCE WITH
80. REINFORCE WITH
81. REINFORCE WITH
82. REINFORCE WITH
83. REINFORCE WITH
84. REINFORCE WITH
85. REINFORCE WITH
86. REINFORCE WITH
87. REINFORCE WITH
88. REINFORCE WITH
89. REINFORCE WITH
90. REINFORCE WITH
91. REINFORCE WITH
92. REINFORCE WITH
93. REINFORCE WITH
94. REINFORCE WITH
95. REINFORCE WITH
96. REINFORCE WITH
97. REINFORCE WITH
98. REINFORCE WITH
99. REINFORCE WITH
100. REINFORCE WITH

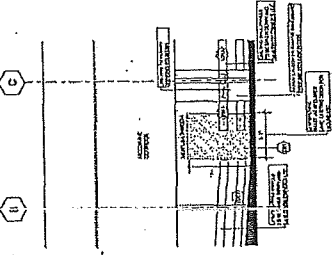

DEMOLITION - RESTROOM DOORS
3/18/18

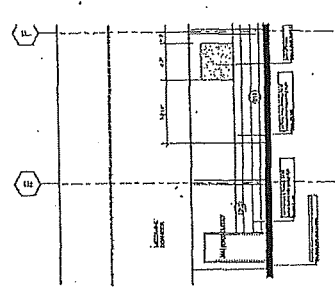

DEMOLITION - JANITOR'S CLOSET
3/18/18

2000 CALIFORNIA STREET, SUITE 200
SAN FRANCISCO, CA 94109
TEL: 415.774.2500
WWW.PW.COM

ISSUED FOR PERKINS SET MAY 29, 2018

161 HYDE STREET
MUNICIPAL MARKET
HALL
401 HYDE STREET
SAN FRANCISCO, CA 94102

L'COCCINA
ARCHITECTS
2545 FOLSOM STREET SAN
FRANCISCO, CA 94110

PROJECT
EST. 2007

SECTION INDEX
A10-01

FLOOR PLAN LEGEND

1	2	3	4	5	6	7	8	9	10	11	12	13	14	15	16	17	18	19	20	21	22	23	24	25	26	27	28	29	30	31	32	33	34	35	36	37	38	39	40	41	42	43	44	45	46	47	48	49	50	51	52	53	54	55	56	57	58	59	60	61	62	63	64	65	66	67	68	69	70	71	72	73	74	75	76	77	78	79	80	81	82	83	84	85	86	87	88	89	90	91	92	93	94	95	96	97	98	99	100
---	---	---	---	---	---	---	---	---	----	----	----	----	----	----	----	----	----	----	----	----	----	----	----	----	----	----	----	----	----	----	----	----	----	----	----	----	----	----	----	----	----	----	----	----	----	----	----	----	----	----	----	----	----	----	----	----	----	----	----	----	----	----	----	----	----	----	----	----	----	----	----	----	----	----	----	----	----	----	----	----	----	----	----	----	----	----	----	----	----	----	----	----	----	----	----	----	----	----	-----

FLOOR PLAN GENERAL NOTES

1. ALL DIMENSIONS ARE TO FACE UNLESS OTHERWISE NOTED.
2. FINISHES ARE TO BE AS SHOWN ON THE FINISH SCHEDULE.
3. REFER TO THE ARCHITECTURAL SPECIFICATIONS FOR MATERIALS AND METHODS.
4. ALL WORK IS TO BE IN ACCORDANCE WITH THE CALIFORNIA BUILDING CODE.
5. THE CONTRACTOR SHALL BE RESPONSIBLE FOR OBTAINING ALL NECESSARY PERMITS.
6. ALL UTILITIES ARE TO BE PROTECTED AND DEEPER THAN THE FINISH FLOOR.
7. THE CONTRACTOR SHALL MAINTAIN ACCESS TO ALL ADJACENT PROPERTIES.
8. ALL WORK IS TO BE COMPLETED WITHIN THE SPECIFIED TIME FRAME.
9. THE CONTRACTOR SHALL MAINTAIN A CLEAN AND SAFE WORK SITE.
10. ALL MATERIALS AND METHODS SHALL BE APPROVED BY THE ARCHITECT.
11. THE CONTRACTOR SHALL BE RESPONSIBLE FOR THE PROTECTION OF EXISTING UTILITIES.
12. ALL WORK IS TO BE COMPLETED IN ACCORDANCE WITH THE CONTRACT DOCUMENTS.
13. THE CONTRACTOR SHALL MAINTAIN ACCESS TO ALL ADJACENT PROPERTIES.
14. ALL WORK IS TO BE COMPLETED WITHIN THE SPECIFIED TIME FRAME.
15. THE CONTRACTOR SHALL MAINTAIN A CLEAN AND SAFE WORK SITE.
16. ALL MATERIALS AND METHODS SHALL BE APPROVED BY THE ARCHITECT.
17. THE CONTRACTOR SHALL BE RESPONSIBLE FOR THE PROTECTION OF EXISTING UTILITIES.
18. ALL WORK IS TO BE COMPLETED IN ACCORDANCE WITH THE CONTRACT DOCUMENTS.
19. THE CONTRACTOR SHALL MAINTAIN ACCESS TO ALL ADJACENT PROPERTIES.
20. ALL WORK IS TO BE COMPLETED WITHIN THE SPECIFIED TIME FRAME.
21. THE CONTRACTOR SHALL MAINTAIN A CLEAN AND SAFE WORK SITE.
22. ALL MATERIALS AND METHODS SHALL BE APPROVED BY THE ARCHITECT.
23. THE CONTRACTOR SHALL BE RESPONSIBLE FOR THE PROTECTION OF EXISTING UTILITIES.
24. ALL WORK IS TO BE COMPLETED IN ACCORDANCE WITH THE CONTRACT DOCUMENTS.
25. THE CONTRACTOR SHALL MAINTAIN ACCESS TO ALL ADJACENT PROPERTIES.
26. ALL WORK IS TO BE COMPLETED WITHIN THE SPECIFIED TIME FRAME.
27. THE CONTRACTOR SHALL MAINTAIN A CLEAN AND SAFE WORK SITE.
28. ALL MATERIALS AND METHODS SHALL BE APPROVED BY THE ARCHITECT.
29. THE CONTRACTOR SHALL BE RESPONSIBLE FOR THE PROTECTION OF EXISTING UTILITIES.
30. ALL WORK IS TO BE COMPLETED IN ACCORDANCE WITH THE CONTRACT DOCUMENTS.
31. THE CONTRACTOR SHALL MAINTAIN ACCESS TO ALL ADJACENT PROPERTIES.
32. ALL WORK IS TO BE COMPLETED WITHIN THE SPECIFIED TIME FRAME.
33. THE CONTRACTOR SHALL MAINTAIN A CLEAN AND SAFE WORK SITE.
34. ALL MATERIALS AND METHODS SHALL BE APPROVED BY THE ARCHITECT.
35. THE CONTRACTOR SHALL BE RESPONSIBLE FOR THE PROTECTION OF EXISTING UTILITIES.
36. ALL WORK IS TO BE COMPLETED IN ACCORDANCE WITH THE CONTRACT DOCUMENTS.
37. THE CONTRACTOR SHALL MAINTAIN ACCESS TO ALL ADJACENT PROPERTIES.
38. ALL WORK IS TO BE COMPLETED WITHIN THE SPECIFIED TIME FRAME.
39. THE CONTRACTOR SHALL MAINTAIN A CLEAN AND SAFE WORK SITE.
40. ALL MATERIALS AND METHODS SHALL BE APPROVED BY THE ARCHITECT.
41. THE CONTRACTOR SHALL BE RESPONSIBLE FOR THE PROTECTION OF EXISTING UTILITIES.
42. ALL WORK IS TO BE COMPLETED IN ACCORDANCE WITH THE CONTRACT DOCUMENTS.
43. THE CONTRACTOR SHALL MAINTAIN ACCESS TO ALL ADJACENT PROPERTIES.
44. ALL WORK IS TO BE COMPLETED WITHIN THE SPECIFIED TIME FRAME.
45. THE CONTRACTOR SHALL MAINTAIN A CLEAN AND SAFE WORK SITE.
46. ALL MATERIALS AND METHODS SHALL BE APPROVED BY THE ARCHITECT.
47. THE CONTRACTOR SHALL BE RESPONSIBLE FOR THE PROTECTION OF EXISTING UTILITIES.
48. ALL WORK IS TO BE COMPLETED IN ACCORDANCE WITH THE CONTRACT DOCUMENTS.
49. THE CONTRACTOR SHALL MAINTAIN ACCESS TO ALL ADJACENT PROPERTIES.
50. ALL WORK IS TO BE COMPLETED WITHIN THE SPECIFIED TIME FRAME.
51. THE CONTRACTOR SHALL MAINTAIN A CLEAN AND SAFE WORK SITE.
52. ALL MATERIALS AND METHODS SHALL BE APPROVED BY THE ARCHITECT.
53. THE CONTRACTOR SHALL BE RESPONSIBLE FOR THE PROTECTION OF EXISTING UTILITIES.
54. ALL WORK IS TO BE COMPLETED IN ACCORDANCE WITH THE CONTRACT DOCUMENTS.
55. THE CONTRACTOR SHALL MAINTAIN ACCESS TO ALL ADJACENT PROPERTIES.
56. ALL WORK IS TO BE COMPLETED WITHIN THE SPECIFIED TIME FRAME.
57. THE CONTRACTOR SHALL MAINTAIN A CLEAN AND SAFE WORK SITE.
58. ALL MATERIALS AND METHODS SHALL BE APPROVED BY THE ARCHITECT.
59. THE CONTRACTOR SHALL BE RESPONSIBLE FOR THE PROTECTION OF EXISTING UTILITIES.
60. ALL WORK IS TO BE COMPLETED IN ACCORDANCE WITH THE CONTRACT DOCUMENTS.
61. THE CONTRACTOR SHALL MAINTAIN ACCESS TO ALL ADJACENT PROPERTIES.
62. ALL WORK IS TO BE COMPLETED WITHIN THE SPECIFIED TIME FRAME.
63. THE CONTRACTOR SHALL MAINTAIN A CLEAN AND SAFE WORK SITE.
64. ALL MATERIALS AND METHODS SHALL BE APPROVED BY THE ARCHITECT.
65. THE CONTRACTOR SHALL BE RESPONSIBLE FOR THE PROTECTION OF EXISTING UTILITIES.
66. ALL WORK IS TO BE COMPLETED IN ACCORDANCE WITH THE CONTRACT DOCUMENTS.
67. THE CONTRACTOR SHALL MAINTAIN ACCESS TO ALL ADJACENT PROPERTIES.
68. ALL WORK IS TO BE COMPLETED WITHIN THE SPECIFIED TIME FRAME.
69. THE CONTRACTOR SHALL MAINTAIN A CLEAN AND SAFE WORK SITE.
70. ALL MATERIALS AND METHODS SHALL BE APPROVED BY THE ARCHITECT.
71. THE CONTRACTOR SHALL BE RESPONSIBLE FOR THE PROTECTION OF EXISTING UTILITIES.
72. ALL WORK IS TO BE COMPLETED IN ACCORDANCE WITH THE CONTRACT DOCUMENTS.
73. THE CONTRACTOR SHALL MAINTAIN ACCESS TO ALL ADJACENT PROPERTIES.
74. ALL WORK IS TO BE COMPLETED WITHIN THE SPECIFIED TIME FRAME.
75. THE CONTRACTOR SHALL MAINTAIN A CLEAN AND SAFE WORK SITE.
76. ALL MATERIALS AND METHODS SHALL BE APPROVED BY THE ARCHITECT.
77. THE CONTRACTOR SHALL BE RESPONSIBLE FOR THE PROTECTION OF EXISTING UTILITIES.
78. ALL WORK IS TO BE COMPLETED IN ACCORDANCE WITH THE CONTRACT DOCUMENTS.
79. THE CONTRACTOR SHALL MAINTAIN ACCESS TO ALL ADJACENT PROPERTIES.
80. ALL WORK IS TO BE COMPLETED WITHIN THE SPECIFIED TIME FRAME.
81. THE CONTRACTOR SHALL MAINTAIN A CLEAN AND SAFE WORK SITE.
82. ALL MATERIALS AND METHODS SHALL BE APPROVED BY THE ARCHITECT.
83. THE CONTRACTOR SHALL BE RESPONSIBLE FOR THE PROTECTION OF EXISTING UTILITIES.
84. ALL WORK IS TO BE COMPLETED IN ACCORDANCE WITH THE CONTRACT DOCUMENTS.
85. THE CONTRACTOR SHALL MAINTAIN ACCESS TO ALL ADJACENT PROPERTIES.
86. ALL WORK IS TO BE COMPLETED WITHIN THE SPECIFIED TIME FRAME.
87. THE CONTRACTOR SHALL MAINTAIN A CLEAN AND SAFE WORK SITE.
88. ALL MATERIALS AND METHODS SHALL BE APPROVED BY THE ARCHITECT.
89. THE CONTRACTOR SHALL BE RESPONSIBLE FOR THE PROTECTION OF EXISTING UTILITIES.
90. ALL WORK IS TO BE COMPLETED IN ACCORDANCE WITH THE CONTRACT DOCUMENTS.
91. THE CONTRACTOR SHALL MAINTAIN ACCESS TO ALL ADJACENT PROPERTIES.
92. ALL WORK IS TO BE COMPLETED WITHIN THE SPECIFIED TIME FRAME.
93. THE CONTRACTOR SHALL MAINTAIN A CLEAN AND SAFE WORK SITE.
94. ALL MATERIALS AND METHODS SHALL BE APPROVED BY THE ARCHITECT.
95. THE CONTRACTOR SHALL BE RESPONSIBLE FOR THE PROTECTION OF EXISTING UTILITIES.
96. ALL WORK IS TO BE COMPLETED IN ACCORDANCE WITH THE CONTRACT DOCUMENTS.
97. THE CONTRACTOR SHALL MAINTAIN ACCESS TO ALL ADJACENT PROPERTIES.
98. ALL WORK IS TO BE COMPLETED WITHIN THE SPECIFIED TIME FRAME.
99. THE CONTRACTOR SHALL MAINTAIN A CLEAN AND SAFE WORK SITE.
100. ALL MATERIALS AND METHODS SHALL BE APPROVED BY THE ARCHITECT.

FLOOR PLAN NOTES BY NUMBER

NO.	DESCRIPTION
1	MEZZANINE FLOOR PLAN
2	LEVEL 01 - FLOOR PLAN
3	MEZZANINE FLOOR PLAN
4	LEVEL 01 - FLOOR PLAN
5	MEZZANINE FLOOR PLAN
6	LEVEL 01 - FLOOR PLAN
7	MEZZANINE FLOOR PLAN
8	LEVEL 01 - FLOOR PLAN
9	MEZZANINE FLOOR PLAN
10	LEVEL 01 - FLOOR PLAN
11	MEZZANINE FLOOR PLAN
12	LEVEL 01 - FLOOR PLAN
13	MEZZANINE FLOOR PLAN
14	LEVEL 01 - FLOOR PLAN
15	MEZZANINE FLOOR PLAN
16	LEVEL 01 - FLOOR PLAN
17	MEZZANINE FLOOR PLAN
18	LEVEL 01 - FLOOR PLAN
19	MEZZANINE FLOOR PLAN
20	LEVEL 01 - FLOOR PLAN
21	MEZZANINE FLOOR PLAN
22	LEVEL 01 - FLOOR PLAN
23	MEZZANINE FLOOR PLAN
24	LEVEL 01 - FLOOR PLAN
25	MEZZANINE FLOOR PLAN
26	LEVEL 01 - FLOOR PLAN
27	MEZZANINE FLOOR PLAN
28	LEVEL 01 - FLOOR PLAN
29	MEZZANINE FLOOR PLAN
30	LEVEL 01 - FLOOR PLAN
31	MEZZANINE FLOOR PLAN
32	LEVEL 01 - FLOOR PLAN
33	MEZZANINE FLOOR PLAN
34	LEVEL 01 - FLOOR PLAN
35	MEZZANINE FLOOR PLAN
36	LEVEL 01 - FLOOR PLAN
37	MEZZANINE FLOOR PLAN
38	LEVEL 01 - FLOOR PLAN
39	MEZZANINE FLOOR PLAN
40	LEVEL 01 - FLOOR PLAN
41	MEZZANINE FLOOR PLAN
42	LEVEL 01 - FLOOR PLAN
43	MEZZANINE FLOOR PLAN
44	LEVEL 01 - FLOOR PLAN
45	MEZZANINE FLOOR PLAN
46	LEVEL 01 - FLOOR PLAN
47	MEZZANINE FLOOR PLAN
48	LEVEL 01 - FLOOR PLAN
49	MEZZANINE FLOOR PLAN
50	LEVEL 01 - FLOOR PLAN
51	MEZZANINE FLOOR PLAN
52	LEVEL 01 - FLOOR PLAN
53	MEZZANINE FLOOR PLAN
54	LEVEL 01 - FLOOR PLAN
55	MEZZANINE FLOOR PLAN
56	LEVEL 01 - FLOOR PLAN
57	MEZZANINE FLOOR PLAN
58	LEVEL 01 - FLOOR PLAN
59	MEZZANINE FLOOR PLAN
60	LEVEL 01 - FLOOR PLAN
61	MEZZANINE FLOOR PLAN
62	LEVEL 01 - FLOOR PLAN
63	MEZZANINE FLOOR PLAN
64	LEVEL 01 - FLOOR PLAN
65	MEZZANINE FLOOR PLAN
66	LEVEL 01 - FLOOR PLAN
67	MEZZANINE FLOOR PLAN
68	LEVEL 01 - FLOOR PLAN
69	MEZZANINE FLOOR PLAN
70	LEVEL 01 - FLOOR PLAN
71	MEZZANINE FLOOR PLAN
72	LEVEL 01 - FLOOR PLAN
73	MEZZANINE FLOOR PLAN
74	LEVEL 01 - FLOOR PLAN
75	MEZZANINE FLOOR PLAN
76	LEVEL 01 - FLOOR PLAN
77	MEZZANINE FLOOR PLAN
78	LEVEL 01 - FLOOR PLAN
79	MEZZANINE FLOOR PLAN
80	LEVEL 01 - FLOOR PLAN
81	MEZZANINE FLOOR PLAN
82	LEVEL 01 - FLOOR PLAN
83	MEZZANINE FLOOR PLAN
84	LEVEL 01 - FLOOR PLAN
85	MEZZANINE FLOOR PLAN
86	LEVEL 01 - FLOOR PLAN
87	MEZZANINE FLOOR PLAN
88	LEVEL 01 - FLOOR PLAN
89	MEZZANINE FLOOR PLAN
90	LEVEL 01 - FLOOR PLAN
91	MEZZANINE FLOOR PLAN
92	LEVEL 01 - FLOOR PLAN
93	MEZZANINE FLOOR PLAN
94	LEVEL 01 - FLOOR PLAN
95	MEZZANINE FLOOR PLAN
96	LEVEL 01 - FLOOR PLAN
97	MEZZANINE FLOOR PLAN
98	LEVEL 01 - FLOOR PLAN
99	MEZZANINE FLOOR PLAN
100	LEVEL 01 - FLOOR PLAN

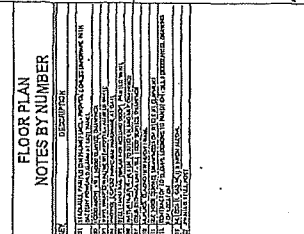

② MEZZANINE - FLOOR PLAN

① LEVEL 01 - FLOOR PLAN

**PERKINS
+ WILL**

100 CALIFORNIA STREET, SUITE 200
SAN FRANCISCO, CA 94111
415 774 2000
WWW.PKP.COM

100 CALIFORNIA STREET, SUITE 200
SAN FRANCISCO, CA 94111
415 774 2000
WWW.PKP.COM

ISSUE FOR PROPOSAL SET MAY 29, 2018

401 RYDE STREET
MUNICIPAL MARKET
SAN FRANCISCO, CA 94102

UCCOCINA
340 CALIFORNIA STREET
SAN FRANCISCO, CA 94102

UCCOCINA
340 CALIFORNIA STREET
SAN FRANCISCO, CA 94102

UCCOCINA
340 CALIFORNIA STREET
SAN FRANCISCO, CA 94102

UCCOCINA
340 CALIFORNIA STREET
SAN FRANCISCO, CA 94102

UCCOCINA
340 CALIFORNIA STREET
SAN FRANCISCO, CA 94102

UCCOCINA
340 CALIFORNIA STREET
SAN FRANCISCO, CA 94102

UCCOCINA
340 CALIFORNIA STREET
SAN FRANCISCO, CA 94102

UCCOCINA
340 CALIFORNIA STREET
SAN FRANCISCO, CA 94102

UCCOCINA
340 CALIFORNIA STREET
SAN FRANCISCO, CA 94102

UCCOCINA
340 CALIFORNIA STREET
SAN FRANCISCO, CA 94102

UCCOCINA
340 CALIFORNIA STREET
SAN FRANCISCO, CA 94102

UCCOCINA
340 CALIFORNIA STREET
SAN FRANCISCO, CA 94102

UCCOCINA
340 CALIFORNIA STREET
SAN FRANCISCO, CA 94102

UCCOCINA
340 CALIFORNIA STREET
SAN FRANCISCO, CA 94102

UCCOCINA
340 CALIFORNIA STREET
SAN FRANCISCO, CA 94102

UCCOCINA
340 CALIFORNIA STREET
SAN FRANCISCO, CA 94102

UCCOCINA
340 CALIFORNIA STREET
SAN FRANCISCO, CA 94102

UCCOCINA
340 CALIFORNIA STREET
SAN FRANCISCO, CA 94102

UCCOCINA
340 CALIFORNIA STREET
SAN FRANCISCO, CA 94102

UCCOCINA
340 CALIFORNIA STREET
SAN FRANCISCO, CA 94102

UCCOCINA
340 CALIFORNIA STREET
SAN FRANCISCO, CA 94102

UCCOCINA
340 CALIFORNIA STREET
SAN FRANCISCO, CA 94102

**ROOF PLAN
GENERAL NOTES**

1. ALL ROOF DECKS SHALL BE CONCRETE ON TOP OF STEEL DECK UNLESS OTHERWISE NOTED.
2. ALL ROOF DECKS SHALL BE FINISHED WITH 2" POLYURETHANE INSULATION ON TOP OF CONCRETE DECK.
3. ALL ROOF DECKS SHALL BE FINISHED WITH 2" POLYURETHANE INSULATION ON TOP OF CONCRETE DECK.
4. ALL ROOF DECKS SHALL BE FINISHED WITH 2" POLYURETHANE INSULATION ON TOP OF CONCRETE DECK.
5. ALL ROOF DECKS SHALL BE FINISHED WITH 2" POLYURETHANE INSULATION ON TOP OF CONCRETE DECK.
6. ALL ROOF DECKS SHALL BE FINISHED WITH 2" POLYURETHANE INSULATION ON TOP OF CONCRETE DECK.
7. ALL ROOF DECKS SHALL BE FINISHED WITH 2" POLYURETHANE INSULATION ON TOP OF CONCRETE DECK.
8. ALL ROOF DECKS SHALL BE FINISHED WITH 2" POLYURETHANE INSULATION ON TOP OF CONCRETE DECK.
9. ALL ROOF DECKS SHALL BE FINISHED WITH 2" POLYURETHANE INSULATION ON TOP OF CONCRETE DECK.
10. ALL ROOF DECKS SHALL BE FINISHED WITH 2" POLYURETHANE INSULATION ON TOP OF CONCRETE DECK.

ROOF PLAN LEGEND

1. ROOF DECK FINISH: 2" POLYURETHANE INSULATION ON TOP OF CONCRETE DECK.

2. ROOF DECK FINISH: 2" POLYURETHANE INSULATION ON TOP OF CONCRETE DECK.

3. ROOF DECK FINISH: 2" POLYURETHANE INSULATION ON TOP OF CONCRETE DECK.

4. ROOF DECK FINISH: 2" POLYURETHANE INSULATION ON TOP OF CONCRETE DECK.

5. ROOF DECK FINISH: 2" POLYURETHANE INSULATION ON TOP OF CONCRETE DECK.

6. ROOF DECK FINISH: 2" POLYURETHANE INSULATION ON TOP OF CONCRETE DECK.

7. ROOF DECK FINISH: 2" POLYURETHANE INSULATION ON TOP OF CONCRETE DECK.

8. ROOF DECK FINISH: 2" POLYURETHANE INSULATION ON TOP OF CONCRETE DECK.

9. ROOF DECK FINISH: 2" POLYURETHANE INSULATION ON TOP OF CONCRETE DECK.

10. ROOF DECK FINISH: 2" POLYURETHANE INSULATION ON TOP OF CONCRETE DECK.

**ROOF PLAN
NOTES BY NUMBER**

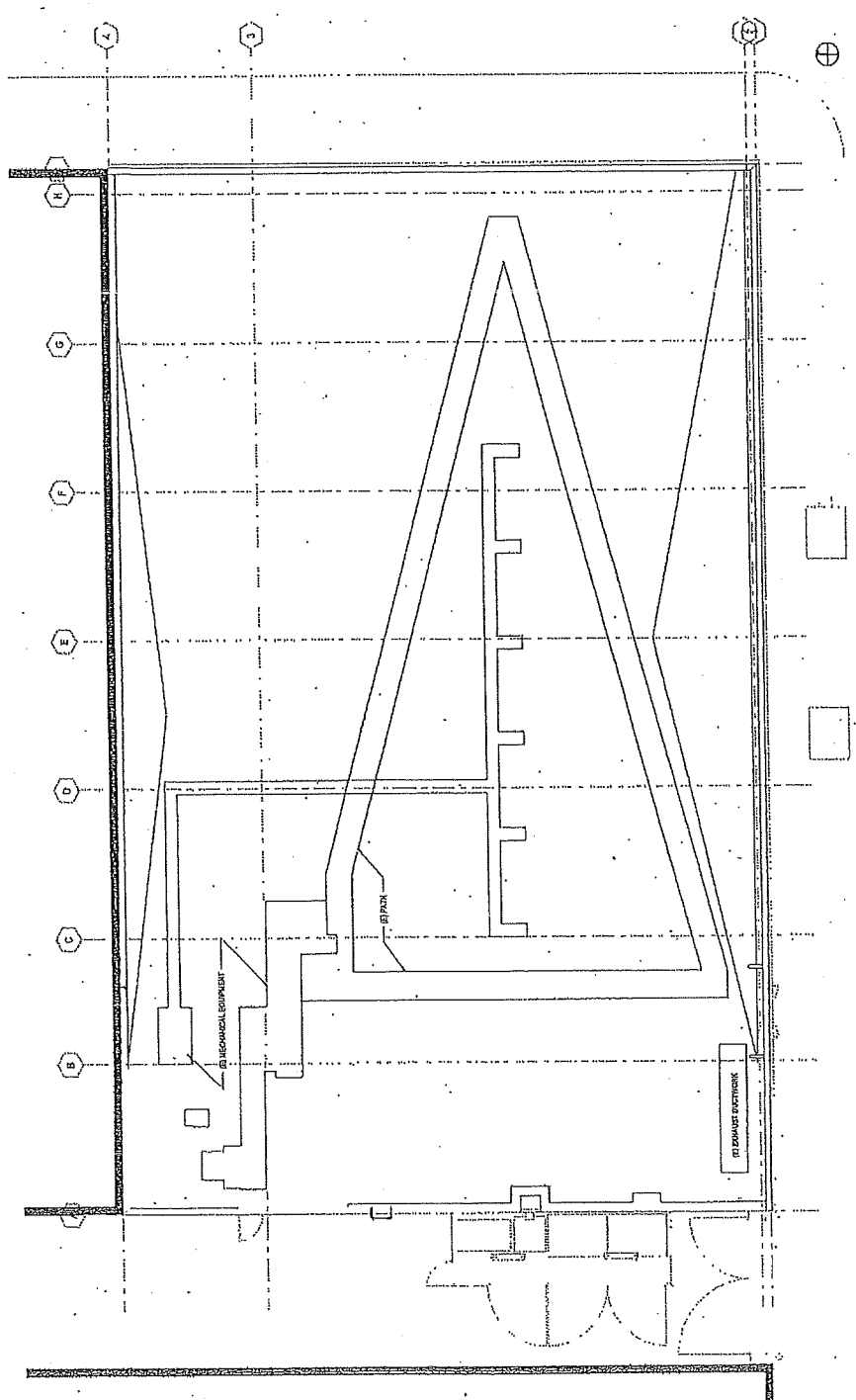

1 ROOF PLAN - REFERENCE ONLY
2018-10-18

PROJECT: 300 RYDE STREET
 CLIENT: MUNICIPAL MARKET
 ARCHITECT: PERKINS+WILL
 DATE: 2018.05.23
 SHEET: A11-01
 DRAWN BY: [REDACTED]
 CHECKED BY: [REDACTED]
 APPROVED BY: [REDACTED]

ALL DIMENSIONS IN MILLIMETERS UNLESS OTHERWISE SPECIFIED.
 DIMENSIONS IN METERS TO THE NEAREST MILLIMETER.

300 RYDE STREET
 MUNICIPAL MARKET
 101 RYDE STREET
 SAN FRANCISCO, CA 94102

LA CUCINA
 RESTAURANT

204 FORTY SEVENTH AVENUE
 SAN FRANCISCO, CA 94110
 PERKINS+WILL

NORTH
 (North arrow symbol)

TITEL	
REFERENCE KITCHEN EQUIPMENT AND FURNITURE PLAN	
SHEET NUMBER	A11-01

GENERAL NOTES

1. ALL DIMENSIONS ARE TO FACE UNLESS OTHERWISE SPECIFIED.
 2. REFER TO ALL OTHER SHEETS FOR RELATED INFORMATION.

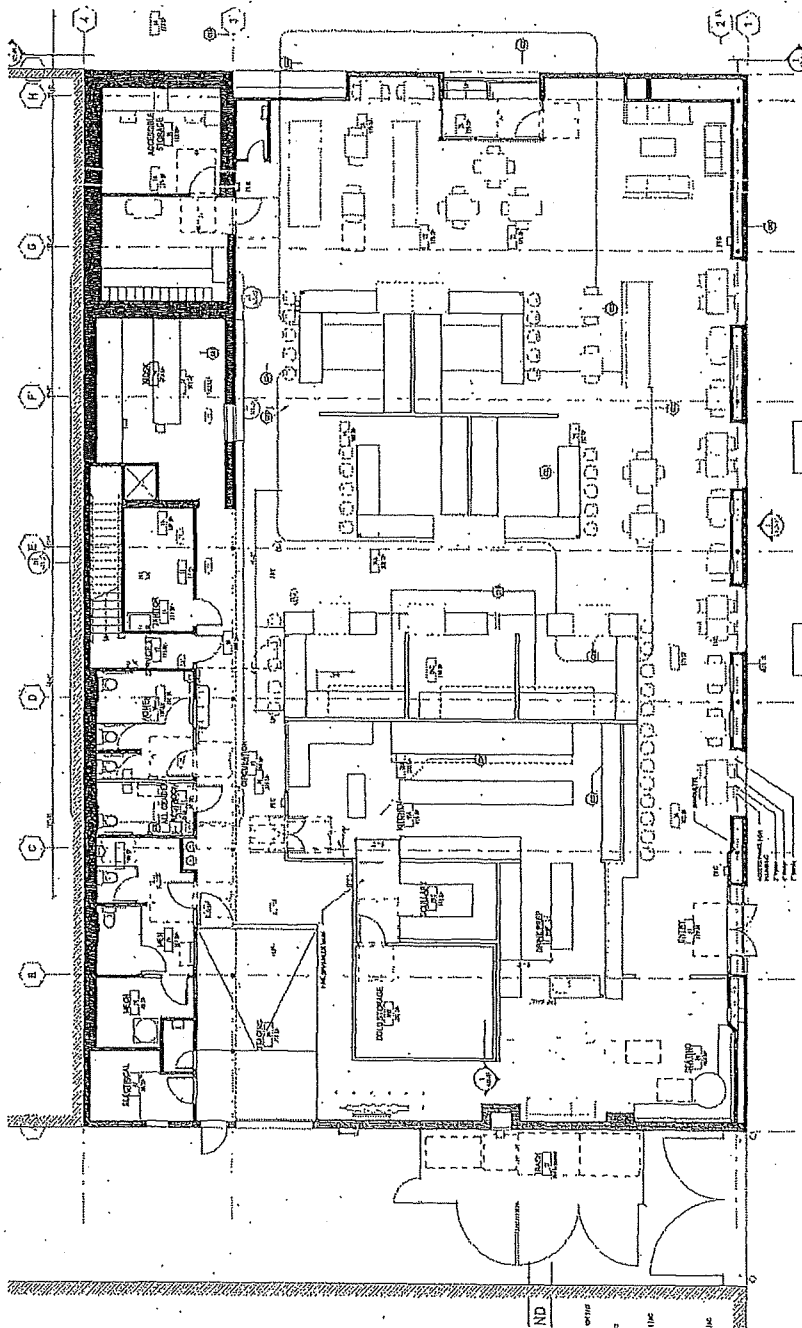

① LEVEL 01 - REFERENCE EQUIPMENT PLAN

**100 HYDE STREET
MUNICIPAL MARKET HALL
701 HYDE STREET
SAN FRANCISCO, CA 94102**

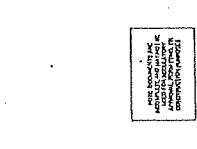

**LA CODINA
3544 PASCADUNO DRIVE
SAN FRANCISCO, CA 94118**

ISSUE FOR PRICING SET MAY 29, 2018

ESTIMATE NUMBER

ESTIMATE NUMBER	
DATE	
PROJECT	
DATE OF ESTIMATE	
ESTIMATOR	
CHECKED BY	
DATE OF CHECK	
APPROVED BY	
DATE OF APPROVAL	

REFLECTED CEILING PLANS
SHEET NUMBER
A12-01

RCP GENERAL NOTES

- ALL DIMENSIONS UNLESS OTHERWISE NOTED.
- CONSTRUCTION SHALL BE IN ACCORDANCE WITH THE SAN FRANCISCO BUILDING CODE.
- VERIFY ALL FIELD DIMENSIONS AND CONDITIONS PRIOR TO CONSTRUCTION.
- CONCRETE SHALL BE CAST AND FINISHED TO THE FINISH INDICATED.
- ALL WALLS TO BE FINISHED WITH THE FINISH INDICATED.
- ALL CEILING TO BE FINISHED WITH THE FINISH INDICATED.
- ALL FLOORS TO BE FINISHED WITH THE FINISH INDICATED.
- ALL ROOFS TO BE FINISHED WITH THE FINISH INDICATED.
- ALL MECHANICAL AND ELECTRICAL WORK SHALL BE INSTALLED IN ACCORDANCE WITH THE SAN FRANCISCO MECHANICAL AND ELECTRICAL CODES.
- ALL PLUMBING WORK SHALL BE INSTALLED IN ACCORDANCE WITH THE SAN FRANCISCO PLUMBING CODE.
- ALL WORK SHALL BE DONE IN ACCORDANCE WITH THE SAN FRANCISCO PLUMBING CODE.
- ALL WORK SHALL BE DONE IN ACCORDANCE WITH THE SAN FRANCISCO ELECTRICAL CODE.
- ALL WORK SHALL BE DONE IN ACCORDANCE WITH THE SAN FRANCISCO MECHANICAL CODE.
- ALL WORK SHALL BE DONE IN ACCORDANCE WITH THE SAN FRANCISCO FIRE CODE.
- ALL WORK SHALL BE DONE IN ACCORDANCE WITH THE SAN FRANCISCO ENVIRONMENTAL CODE.
- ALL WORK SHALL BE DONE IN ACCORDANCE WITH THE SAN FRANCISCO HISTORIC PRESERVATION CODE.

RCP LEGEND

WALL FINISH

- 1. POLYESTER GYP. BOARD
- 2. PLASTER
- 3. GYP. BOARD
- 4. GYP. BOARD
- 5. GYP. BOARD
- 6. GYP. BOARD
- 7. GYP. BOARD
- 8. GYP. BOARD
- 9. GYP. BOARD
- 10. GYP. BOARD
- 11. GYP. BOARD
- 12. GYP. BOARD
- 13. GYP. BOARD
- 14. GYP. BOARD
- 15. GYP. BOARD
- 16. GYP. BOARD
- 17. GYP. BOARD
- 18. GYP. BOARD
- 19. GYP. BOARD
- 20. GYP. BOARD
- 21. GYP. BOARD
- 22. GYP. BOARD
- 23. GYP. BOARD
- 24. GYP. BOARD
- 25. GYP. BOARD
- 26. GYP. BOARD
- 27. GYP. BOARD
- 28. GYP. BOARD
- 29. GYP. BOARD
- 30. GYP. BOARD
- 31. GYP. BOARD
- 32. GYP. BOARD
- 33. GYP. BOARD
- 34. GYP. BOARD
- 35. GYP. BOARD
- 36. GYP. BOARD
- 37. GYP. BOARD
- 38. GYP. BOARD
- 39. GYP. BOARD
- 40. GYP. BOARD
- 41. GYP. BOARD
- 42. GYP. BOARD
- 43. GYP. BOARD
- 44. GYP. BOARD
- 45. GYP. BOARD
- 46. GYP. BOARD
- 47. GYP. BOARD
- 48. GYP. BOARD
- 49. GYP. BOARD
- 50. GYP. BOARD
- 51. GYP. BOARD
- 52. GYP. BOARD
- 53. GYP. BOARD
- 54. GYP. BOARD
- 55. GYP. BOARD
- 56. GYP. BOARD
- 57. GYP. BOARD
- 58. GYP. BOARD
- 59. GYP. BOARD
- 60. GYP. BOARD
- 61. GYP. BOARD
- 62. GYP. BOARD
- 63. GYP. BOARD
- 64. GYP. BOARD
- 65. GYP. BOARD
- 66. GYP. BOARD
- 67. GYP. BOARD
- 68. GYP. BOARD
- 69. GYP. BOARD
- 70. GYP. BOARD
- 71. GYP. BOARD
- 72. GYP. BOARD
- 73. GYP. BOARD
- 74. GYP. BOARD
- 75. GYP. BOARD
- 76. GYP. BOARD
- 77. GYP. BOARD
- 78. GYP. BOARD
- 79. GYP. BOARD
- 80. GYP. BOARD
- 81. GYP. BOARD
- 82. GYP. BOARD
- 83. GYP. BOARD
- 84. GYP. BOARD
- 85. GYP. BOARD
- 86. GYP. BOARD
- 87. GYP. BOARD
- 88. GYP. BOARD
- 89. GYP. BOARD
- 90. GYP. BOARD
- 91. GYP. BOARD
- 92. GYP. BOARD
- 93. GYP. BOARD
- 94. GYP. BOARD
- 95. GYP. BOARD
- 96. GYP. BOARD
- 97. GYP. BOARD
- 98. GYP. BOARD
- 99. GYP. BOARD
- 100. GYP. BOARD

RCP NOTES BY NUMBER

EXPLANATIONS

1. SEE NOTE 1 FOR FINISH

2. SEE NOTE 2 FOR FINISH

3. SEE NOTE 3 FOR FINISH

4. SEE NOTE 4 FOR FINISH

5. SEE NOTE 5 FOR FINISH

6. SEE NOTE 6 FOR FINISH

7. SEE NOTE 7 FOR FINISH

8. SEE NOTE 8 FOR FINISH

9. SEE NOTE 9 FOR FINISH

10. SEE NOTE 10 FOR FINISH

11. SEE NOTE 11 FOR FINISH

12. SEE NOTE 12 FOR FINISH

13. SEE NOTE 13 FOR FINISH

14. SEE NOTE 14 FOR FINISH

15. SEE NOTE 15 FOR FINISH

16. SEE NOTE 16 FOR FINISH

17. SEE NOTE 17 FOR FINISH

18. SEE NOTE 18 FOR FINISH

19. SEE NOTE 19 FOR FINISH

20. SEE NOTE 20 FOR FINISH

21. SEE NOTE 21 FOR FINISH

22. SEE NOTE 22 FOR FINISH

23. SEE NOTE 23 FOR FINISH

24. SEE NOTE 24 FOR FINISH

25. SEE NOTE 25 FOR FINISH

26. SEE NOTE 26 FOR FINISH

27. SEE NOTE 27 FOR FINISH

28. SEE NOTE 28 FOR FINISH

29. SEE NOTE 29 FOR FINISH

30. SEE NOTE 30 FOR FINISH

31. SEE NOTE 31 FOR FINISH

32. SEE NOTE 32 FOR FINISH

33. SEE NOTE 33 FOR FINISH

34. SEE NOTE 34 FOR FINISH

35. SEE NOTE 35 FOR FINISH

36. SEE NOTE 36 FOR FINISH

37. SEE NOTE 37 FOR FINISH

38. SEE NOTE 38 FOR FINISH

39. SEE NOTE 39 FOR FINISH

40. SEE NOTE 40 FOR FINISH

41. SEE NOTE 41 FOR FINISH

42. SEE NOTE 42 FOR FINISH

43. SEE NOTE 43 FOR FINISH

44. SEE NOTE 44 FOR FINISH

45. SEE NOTE 45 FOR FINISH

46. SEE NOTE 46 FOR FINISH

47. SEE NOTE 47 FOR FINISH

48. SEE NOTE 48 FOR FINISH

49. SEE NOTE 49 FOR FINISH

50. SEE NOTE 50 FOR FINISH

51. SEE NOTE 51 FOR FINISH

52. SEE NOTE 52 FOR FINISH

53. SEE NOTE 53 FOR FINISH

54. SEE NOTE 54 FOR FINISH

55. SEE NOTE 55 FOR FINISH

56. SEE NOTE 56 FOR FINISH

57. SEE NOTE 57 FOR FINISH

58. SEE NOTE 58 FOR FINISH

59. SEE NOTE 59 FOR FINISH

60. SEE NOTE 60 FOR FINISH

61. SEE NOTE 61 FOR FINISH

62. SEE NOTE 62 FOR FINISH

63. SEE NOTE 63 FOR FINISH

64. SEE NOTE 64 FOR FINISH

65. SEE NOTE 65 FOR FINISH

66. SEE NOTE 66 FOR FINISH

67. SEE NOTE 67 FOR FINISH

68. SEE NOTE 68 FOR FINISH

69. SEE NOTE 69 FOR FINISH

70. SEE NOTE 70 FOR FINISH

71. SEE NOTE 71 FOR FINISH

72. SEE NOTE 72 FOR FINISH

73. SEE NOTE 73 FOR FINISH

74. SEE NOTE 74 FOR FINISH

75. SEE NOTE 75 FOR FINISH

76. SEE NOTE 76 FOR FINISH

77. SEE NOTE 77 FOR FINISH

78. SEE NOTE 78 FOR FINISH

79. SEE NOTE 79 FOR FINISH

80. SEE NOTE 80 FOR FINISH

81. SEE NOTE 81 FOR FINISH

82. SEE NOTE 82 FOR FINISH

83. SEE NOTE 83 FOR FINISH

84. SEE NOTE 84 FOR FINISH

85. SEE NOTE 85 FOR FINISH

86. SEE NOTE 86 FOR FINISH

87. SEE NOTE 87 FOR FINISH

88. SEE NOTE 88 FOR FINISH

89. SEE NOTE 89 FOR FINISH

90. SEE NOTE 90 FOR FINISH

91. SEE NOTE 91 FOR FINISH

92. SEE NOTE 92 FOR FINISH

93. SEE NOTE 93 FOR FINISH

94. SEE NOTE 94 FOR FINISH

95. SEE NOTE 95 FOR FINISH

96. SEE NOTE 96 FOR FINISH

97. SEE NOTE 97 FOR FINISH

98. SEE NOTE 98 FOR FINISH

99. SEE NOTE 99 FOR FINISH

100. SEE NOTE 100 FOR FINISH

LIGHT FIXTURE SCHEDULE

NO.	DESCRIPTION	QUANTITY	REMARKS
1
2
3
4
5
6
7
8
9
10
11
12
13
14
15
16
17
18
19
20
21
22
23
24
25
26
27
28
29
30
31
32
33
34
35
36
37
38
39
40
41
42
43
44
45
46
47
48
49
50

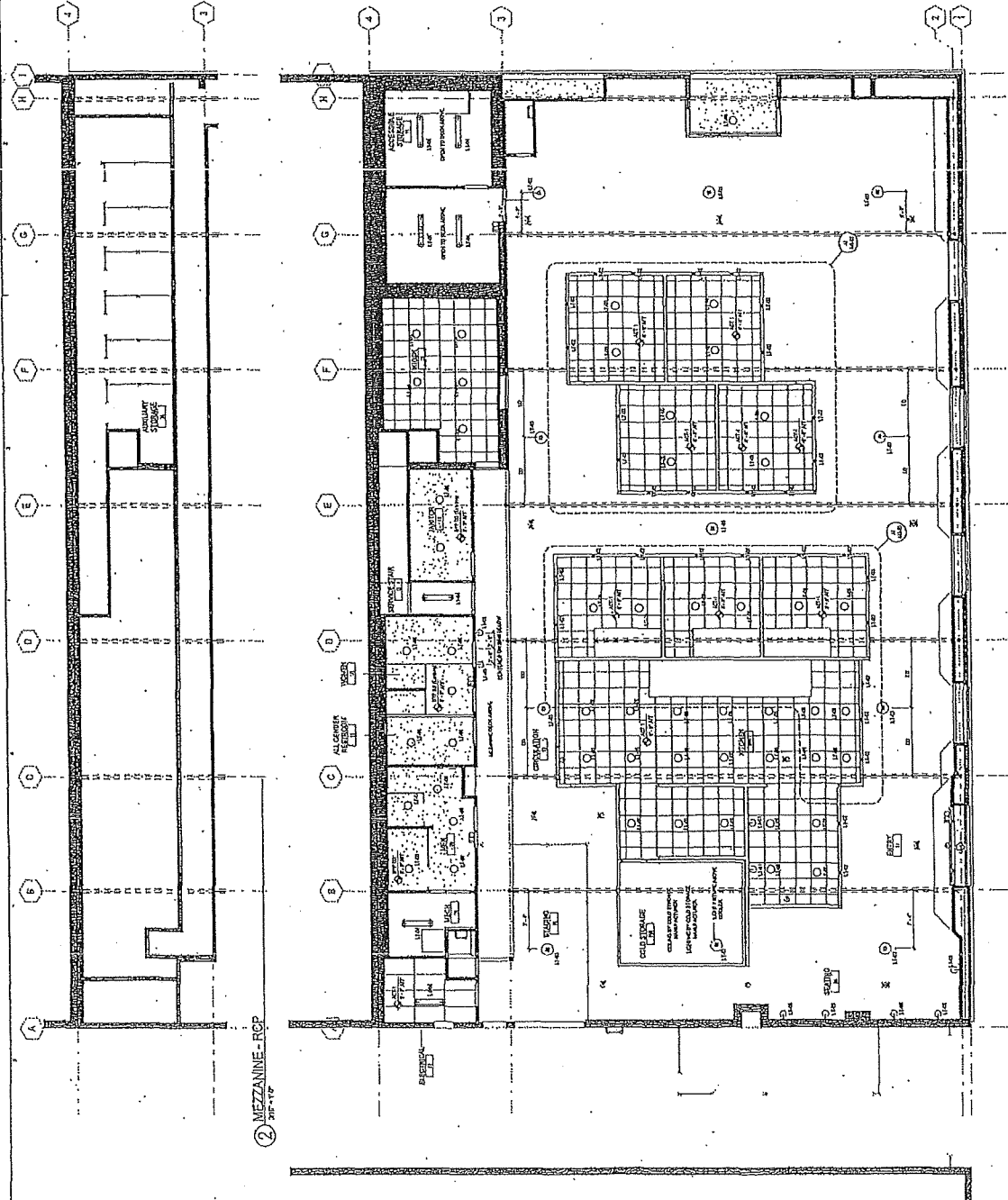

**2 MEZZANINE - RCP
318-328**

**1 LEVEL 01 - RCP
318-328**

**PERKINS
+ WILL**

101 HYDE STREET
MUNICIPAL MARKET
SAN FRANCISCO, CA 94102

181 HYDE STREET
HALL
SAN FRANCISCO, CA 94102

LEOCINA
L.A. COCINA
384 FOLSOM STREET
SAN FRANCISCO, CA 94102

ISSUE FOR PRICING SET MAY 29, 2019

PROJECT

101 HYDE STREET
MUNICIPAL MARKET
SAN FRANCISCO, CA 94102

181 HYDE STREET
HALL
SAN FRANCISCO, CA 94102

LEOCINA
L.A. COCINA
384 FOLSOM STREET
SAN FRANCISCO, CA 94102

ISSUE FOR PRICING SET MAY 29, 2019

PROJECT

101 HYDE STREET
MUNICIPAL MARKET
SAN FRANCISCO, CA 94102

181 HYDE STREET
HALL
SAN FRANCISCO, CA 94102

LEOCINA
L.A. COCINA
384 FOLSOM STREET
SAN FRANCISCO, CA 94102

ISSUE FOR PRICING SET MAY 29, 2019

PROJECT

101 HYDE STREET
MUNICIPAL MARKET
SAN FRANCISCO, CA 94102

181 HYDE STREET
HALL
SAN FRANCISCO, CA 94102

LEOCINA
L.A. COCINA
384 FOLSOM STREET
SAN FRANCISCO, CA 94102

**INTERIOR FINISH PLAN
GENERAL NOTES**

1. ALL FINISHES TO BE INSTALLED IN ACCORDANCE WITH THE MANUFACTURER'S RECOMMENDATIONS.
2. REFER TO THE FINISH SCHEDULE FOR MATERIAL SPECIFICATIONS.
3. REFER TO THE FINISH SCHEDULE FOR MATERIAL SPECIFICATIONS.

INTERIOR FINISH PLAN LEGEND

WALL FINISHES

- 1. GYP. BOARD (5/8" THICK) OVER STUDS AND JOISTS
- 2. GYP. BOARD (5/8" THICK) OVER STUDS AND JOISTS
- 3. GYP. BOARD (5/8" THICK) OVER STUDS AND JOISTS

FLOOR FINISHES

- 1. POLISHED CONCRETE
- 2. POLISHED CONCRETE
- 3. POLISHED CONCRETE

CEILING FINISHES

- 1. POP (5/8" THICK) OVER STUDS AND JOISTS
- 2. POP (5/8" THICK) OVER STUDS AND JOISTS
- 3. POP (5/8" THICK) OVER STUDS AND JOISTS

**INTERIOR FINISH PLAN
NOTES BY NUMBER**

1. FINISH TO BE INSTALLED IN ACCORDANCE WITH THE MANUFACTURER'S RECOMMENDATIONS.

2. REFER TO THE FINISH SCHEDULE FOR MATERIAL SPECIFICATIONS.

3. REFER TO THE FINISH SCHEDULE FOR MATERIAL SPECIFICATIONS.

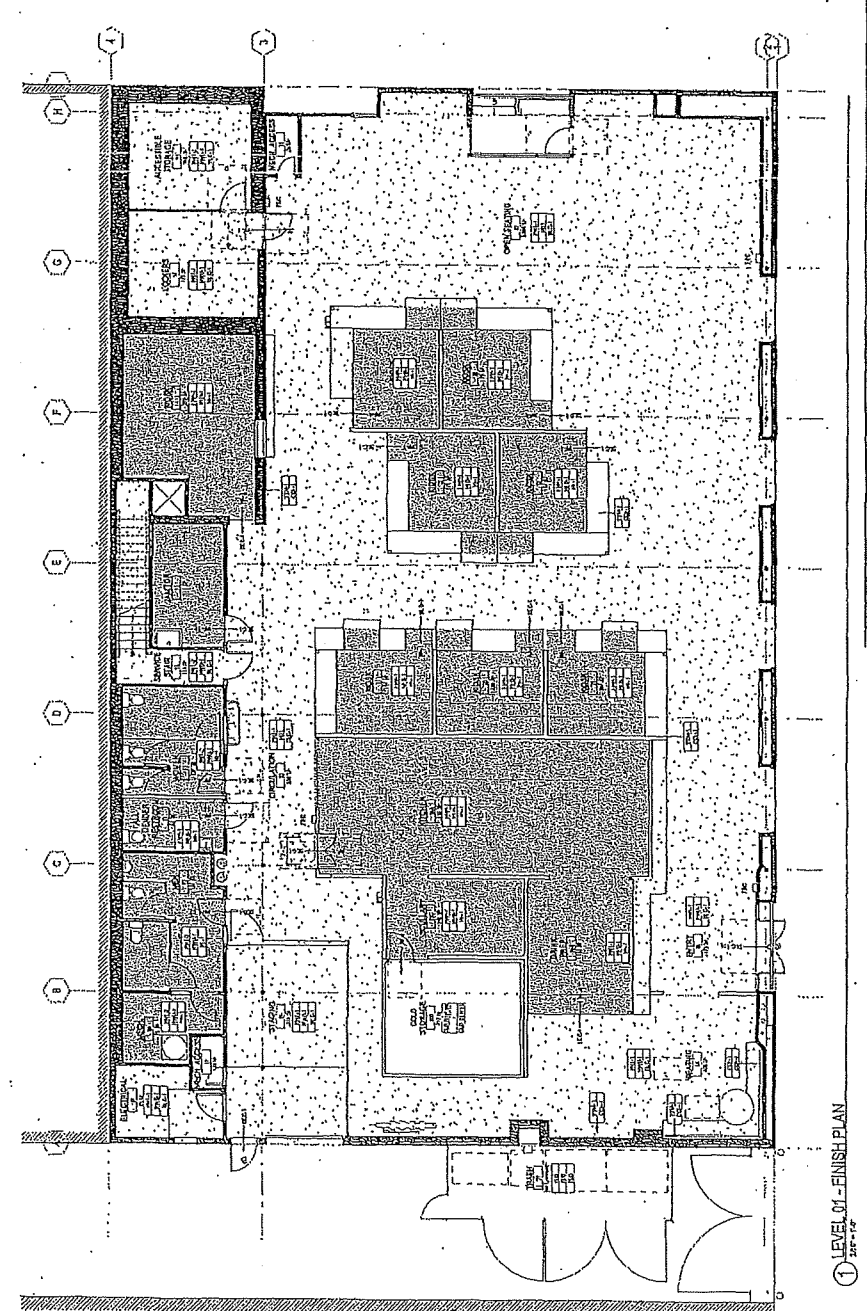

MATERIAL SCHEDULE

ITEM	QUANTITY	UNIT	DESCRIPTION	DATE	BY
1	100	SQ. FT.	POLISHED CONCRETE	12/15/18	JLW
2	100	SQ. FT.	POLISHED CONCRETE	12/15/18	JLW
3	100	SQ. FT.	POLISHED CONCRETE	12/15/18	JLW
4	100	SQ. FT.	POLISHED CONCRETE	12/15/18	JLW
5	100	SQ. FT.	POLISHED CONCRETE	12/15/18	JLW
6	100	SQ. FT.	POLISHED CONCRETE	12/15/18	JLW
7	100	SQ. FT.	POLISHED CONCRETE	12/15/18	JLW
8	100	SQ. FT.	POLISHED CONCRETE	12/15/18	JLW
9	100	SQ. FT.	POLISHED CONCRETE	12/15/18	JLW
10	100	SQ. FT.	POLISHED CONCRETE	12/15/18	JLW
11	100	SQ. FT.	POLISHED CONCRETE	12/15/18	JLW
12	100	SQ. FT.	POLISHED CONCRETE	12/15/18	JLW
13	100	SQ. FT.	POLISHED CONCRETE	12/15/18	JLW
14	100	SQ. FT.	POLISHED CONCRETE	12/15/18	JLW
15	100	SQ. FT.	POLISHED CONCRETE	12/15/18	JLW
16	100	SQ. FT.	POLISHED CONCRETE	12/15/18	JLW
17	100	SQ. FT.	POLISHED CONCRETE	12/15/18	JLW
18	100	SQ. FT.	POLISHED CONCRETE	12/15/18	JLW
19	100	SQ. FT.	POLISHED CONCRETE	12/15/18	JLW
20	100	SQ. FT.	POLISHED CONCRETE	12/15/18	JLW

PERKINS
+WILL

700 Market Street
San Francisco, CA 94102
415.774.8000
www.perkinswill.com

ARCHITECT
300 SOUTH FOLSOM STREET
SAN FRANCISCO, CA 94102
415.774.8000
www.perkinswill.com

LA COCCINA
298 FOLSOM STREET
SAN FRANCISCO, CA 94102
415.774.8000
www.lacoccina.com

THE CONTRACTOR SHALL BE RESPONSIBLE FOR OBTAINING ALL NECESSARY PERMITS AND APPROVALS FROM THE APPLICABLE AGENCIES.

PROJECT

114 HYDE STREET
MUNICIPAL MARKET
HALL
303 HYDE STREET
SAN FRANCISCO, CA 94102

LA COCCINA
298 FOLSOM STREET
SAN FRANCISCO, CA 94102

LA COCCINA
298 FOLSOM STREET
SAN FRANCISCO, CA 94102

ISSUE FOR PRICING SET MAY 29, 2018

DATE CHART

NO.	DATE	DESCRIPTION
1	05/29/18	ISSUE FOR PRICING SET

EXTERIOR
ELEVATIONS

SHEET NUMBER
A20-01

DATE PLOTTED: 05/29/18 10:00 AM

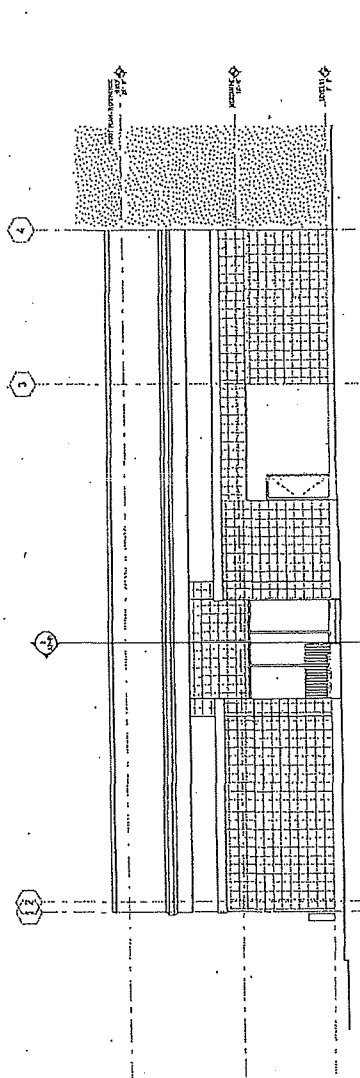

② EAST - HYDE STREET
303' x 12'

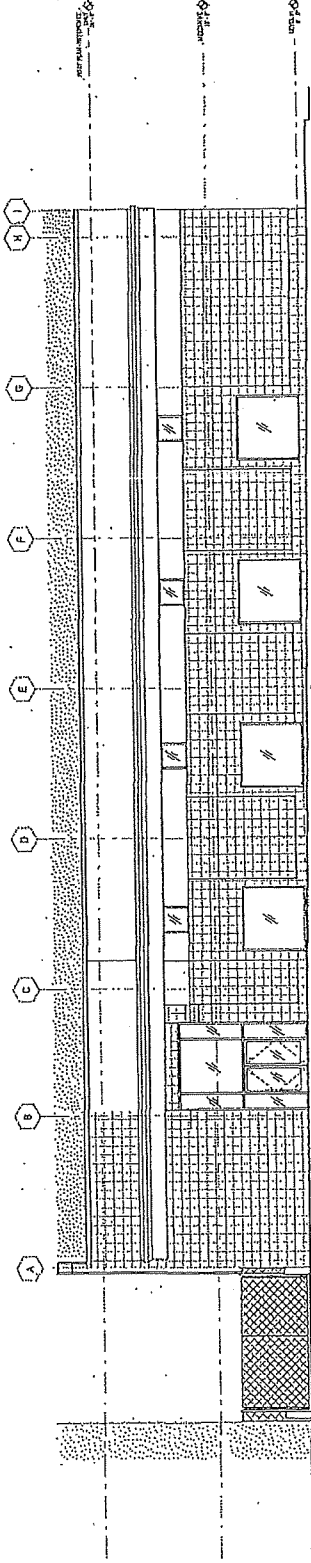

① SOUTH - GOLDEN GATE AVENUE
303' x 12'

**PERKINS
+WILL**

100 CALIFORNIA STREET
SAN FRANCISCO, CA 94111
TEL: 415.774.2500
WWW.PW.COM

ARCHITECTS

100 CALIFORNIA STREET
SAN FRANCISCO, CA 94111
TEL: 415.774.2500
WWW.PW.COM

100 CALIFORNIA STREET
SAN FRANCISCO, CA 94111
TEL: 415.774.2500
WWW.PW.COM

THIS DOCUMENT IS THE PROPERTY OF PERKINS+WILL AND IS TO BE USED ONLY FOR THE PROJECT AND SITE SPECIFICALLY IDENTIFIED HEREIN.

PROJECT

101 HYDE STREET
MUNICIPAL MARKET
SAN FRANCISCO, CA 94102

LA COCINA
ARCHITECTS

LA COCINA
2918 FOLSOM STREET SAN
FRANCISCO, CALIFORNIA

STRUCTURE

NO.	DATE	DESCRIPTION
1	05/29/18	ISSUE FOR PRICING SET

TITLE

REFERENCE OVERALL
BUILDING SECTIONS

SHEET NUMBER

A21-01

DATE: 05/29/18

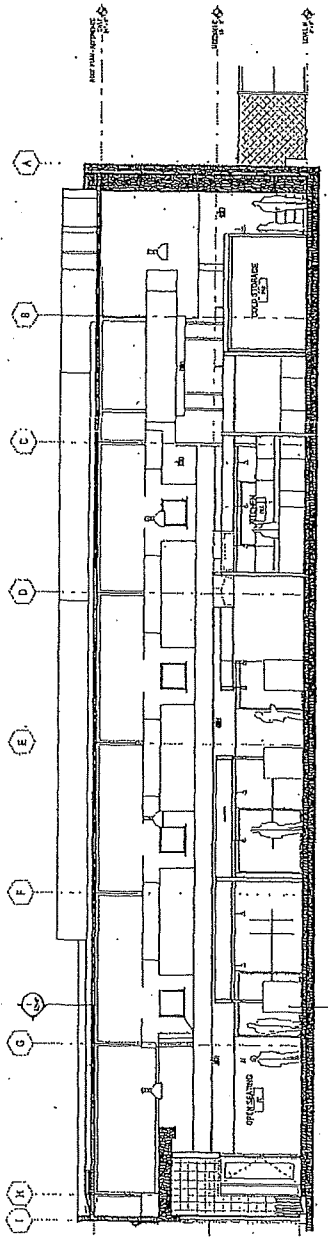

② OVERALL BUILDING SECTION E-W
20'-0" x 12'

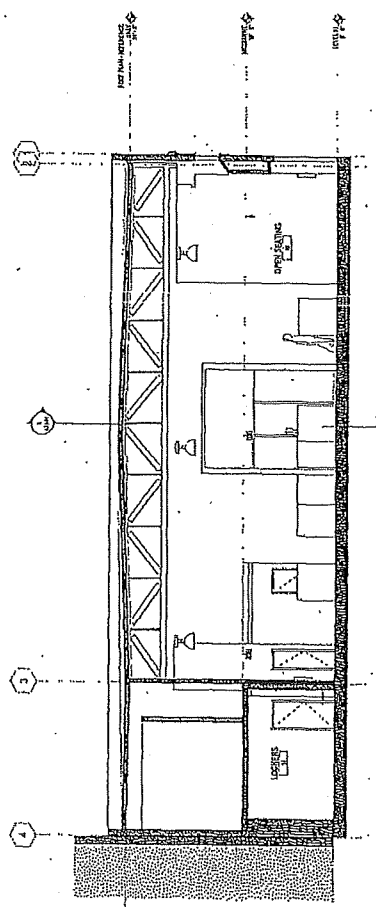

① OVERALL BUILDING SECTION N-S
20'-0" x 12'

PERKINS
+ WILL

1200 CALIFORNIA STREET
SAN FRANCISCO, CA 94109
415.774.8000
WWW.PKP.COM

CONSTRUCTION
1200 CALIFORNIA STREET
SAN FRANCISCO, CA 94109
415.774.8000
WWW.PKP.COM

1200 CALIFORNIA STREET
SAN FRANCISCO, CA 94109
415.774.8000
WWW.PKP.COM

THE INFORMATION
CONTAINED HEREIN
IS FOR GENERAL
REFERENCE ONLY
AND IS NOT TO BE
USED FOR ANY
OTHER PURPOSES.

PROJECT
101 HYDE STREET
MUNICIPAL MARKET
SAN FRANCISCO, CA 94102

101 HYDE STREET
SAN FRANCISCO, CA 94102

LA CUCINA
SAN FRANCISCO, CA 94102

LA CUCINA
SAN FRANCISCO, CA 94102

ISSUE FOR PRICING SET MAY 29, 2018

DATE
2018.05.29

DATE
2018.05.29

TITLE
KIOSKS AT KITCHEN -
ENLARGED PLANS

SHEET NUMBER
A45-03

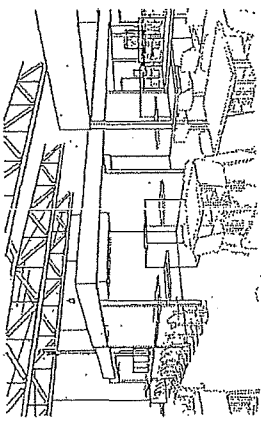

07 PERSPECTIVE OF KIOSK AT KITCHEN

DATE	DESCRIPTION	BY	CHK
05/29/18	ISSUE FOR PRICING SET	PERKINS + WILL	PERKINS + WILL

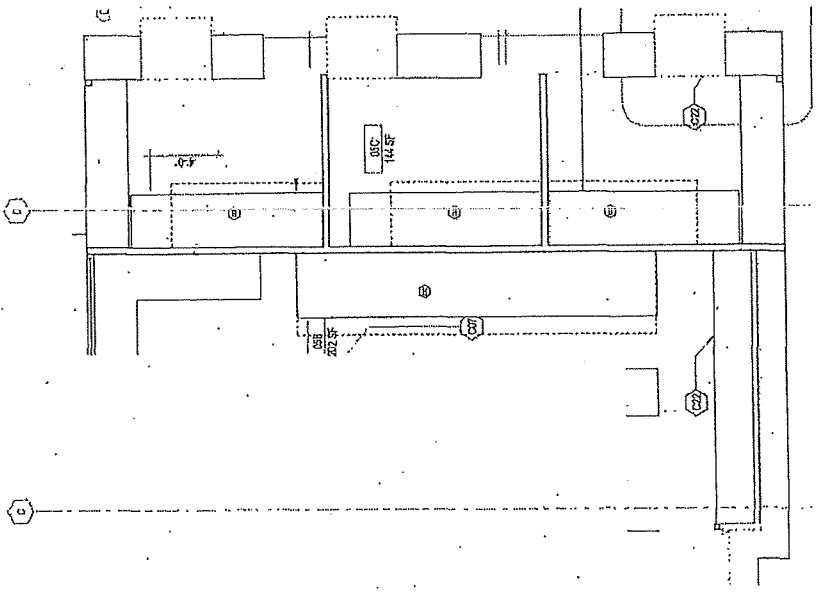

08 ENLARGED PLAN - KIOSKS AT KITCHEN
1/8" = 1'-0"

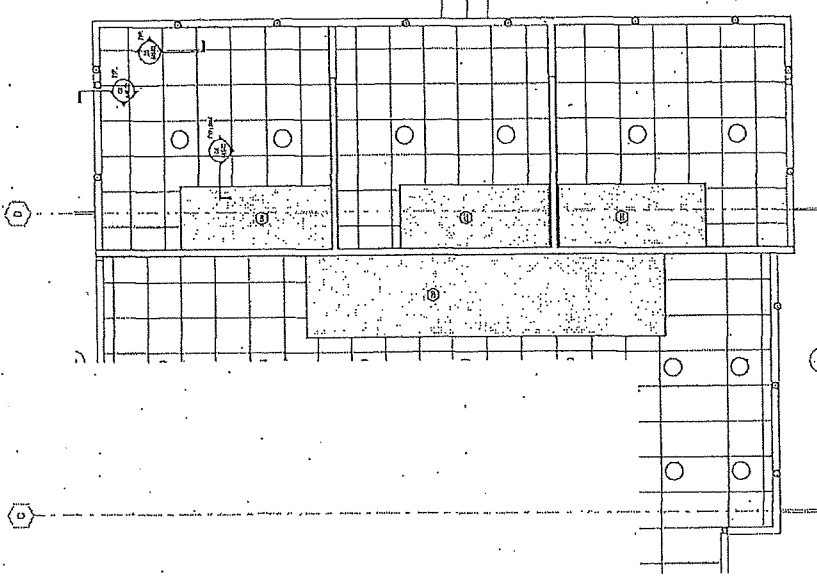

09 ENLARGED REP. - KIOSKS AT KITCHEN
1/8" = 1'-0"



PERKINS

414 HYDE STREET
MUNICIPAL MARKET
HALL
101 HYDE STREET
SAN FRANCISCO, CA 94102



L. COCCINA
2941 FOLSOM STREET, SUITE 200
SAN FRANCISCO, CA 94118
EST. 1982

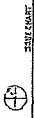

PERKINS

NO.	REVISION	DATE	TITLE

LOCKERS - ENLARGED
PLAN & ELEVATIONS

PROJECT NUMBER
A45-04

SHEET NUMBER
11-5

ISSUE FOR PRICING SET MAY 29, 2018

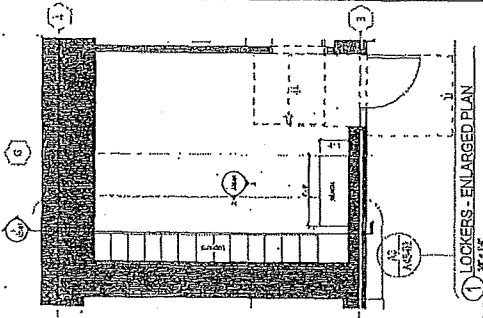
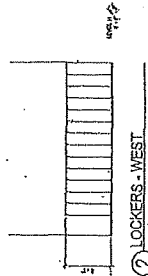
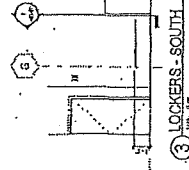
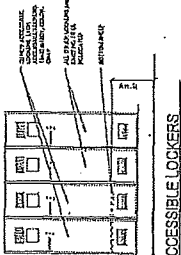



- TYPICAL DETAILS:** THE INFORMATION AND DETAILS ON THIS DRAWING REPRESENT TYPICAL REQUIREMENTS FOR THE INSTALLATION OF SUSPENDED LAY-IN CEILING SYSTEMS WEIGHING NO MORE THAN 4 LBS PER SQUARE FOOT. SEE RCF'S FOR LOCATIONS OF LATER CEILING.
- HANGER WIRES:** PROVIDE 12 GA HANGER WIRES AT 5'-0" O.C. ALONG EACH MAIN RUNNER. PROVIDE 12 GA HANGER WIRES AT 18" O.C. ALONG EACH CROSS RUNNER. CONNECTION DEVICES SHALL BE CAPABLE OF CARRYING NOT LESS THAN 100 POUNDS. PROVIDE COUNTERSINKS WHERE WIRES WHERE SUSPENSION WIRES HANG MORE THAN 1/4" OUT OF PLUMB.
- FERRITER HANGERS:** THE TERMINAL ENDS OF EACH CROSS RUNNER AND MAIN RUNNER SHALL BE PROVIDED WITH FERRITER HANGERS TO MAINTAIN THE CORRECT CEILING DISCONTINUITY WITH 12 GA WIRE OR APPROVED WALL SUPPORT.
- OBSTRUCTIONS:** PROVIDE TRAYS OR EQUIVALENT DEVICES WHERE OBSTRUCTIONS PRECLUDE DIRECT SUSPENSION. TRAYE SUSPENSIONS SHALL BE A MINIMUM OF 1/4" O.C. PER SPAN EXCEEDING 4'-0" UNLESS INDICATED OTHERWISE.
- LATERAL FORCE BRACING:** BRACING SHALL BE PROVIDED TO THE MAIN RUNNERS WITHIN 45° OF THE CROSS RUNNER INTERSECTION AND PLACED IN DEGRESS FROM EACH OTHER AT AN ANGLE NOT EXCEEDING 45° FROM THE PLANE OF THE CEILING. PROVIDE A STRUT FASTENED TO THE MAIN RUNNER AND MAIN RUNNER WITH 1/2" DIA. IN BOTH DIRECTIONS WITH THE FIRST POINT WITHIN 6" FROM EACH WALL. SPACE LATERAL BRACING MEMBERS A MINIMUM OF 2' BACK TO BACK. USE THE GRID AND STRUCTURE TO WHICH CONNECTIONS ARE ATTACHED TO DETERMINE THE BRACING LOADS. BRACING SHALL BE A DESIGN LOAD OF 200 POUNDS PER THE ACTUAL LOAD, WHICHEVER IS GREATER, WITH A SAFETY FACTOR OF 2.
- PROMETER MEMBERS:** ENDS OF MAIN RUNNERS AND CROSS MEMBERS SHALL BE TIED TOGETHER TO PREVENT THEIR SPREADING.
- ATTACHMENT TO FERRITER:** MAIN RUNNERS AND CROSS RUNNERS MAY BE ATTACHED TO THE WALL AND RUNNERS MAINTAINED AT THE OTHER TWO WALLS, AS SHOWN FOR THE APPROVED SYSTEM.
- LIGHTING FIXTURES:** ALL LIGHT FIXTURES TO THE SUSPENDED CEILING SYSTEM ATTACHMENT DEVICES SHALL HAVE A CAPACITY OF 100% OF THE FIXTURE WEIGHT. PROVIDE A MINIMUM ATTACHMENT STRENGTH OF 100 POUNDS PER SQUARE FOOT FOR EACH LIGHTING FIXTURE. SUSPENSION REQUIRED.
- LOADING FIXTURES:** LIGHTING FIXTURES SHALL BE CAPABLE OF CARRYING THE WEIGHT OF THE FIXTURES. PROVIDE A MINIMUM ATTACHMENT STRENGTH OF 100 POUNDS PER SQUARE FOOT FOR EACH LIGHTING FIXTURE. SUSPENSION REQUIRED.
- MISCELLANEOUS:** ALL MAIN RUNNERS SHALL BE CAPABLE OF CARRYING THE WEIGHT OF THE FIXTURES. PROVIDE A MINIMUM ATTACHMENT STRENGTH OF 100 POUNDS PER SQUARE FOOT FOR EACH LIGHTING FIXTURE. SUSPENSION REQUIRED.
- COMPRESSION STRUT:** GENERAL INFORMATION FOR TYPICAL COMPRESSION STRUT SCHEDULE. GENERAL INFORMATION FOR TYPICAL COMPRESSION STRUT SCHEDULE. GENERAL INFORMATION FOR TYPICAL COMPRESSION STRUT SCHEDULE.

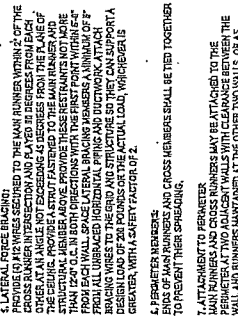

1. TYP. SECT. AT SUSP. TILE CEILING
3'-0" X 3'-0"

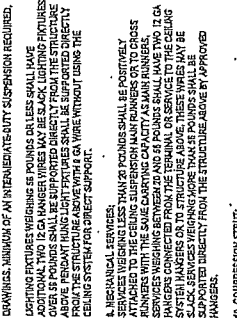

2. TYP. SECT. AT SUSP. TILE CEILING
3'-0" X 3'-0"

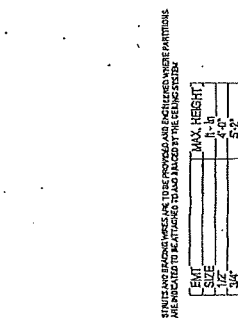

3. TYP. SECT. AT SUSP. TILE CEILING
3'-0" X 3'-0"

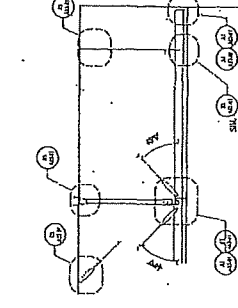

4. TYP. SECT. AT SUSP. TILE CEILING
3'-0" X 3'-0"

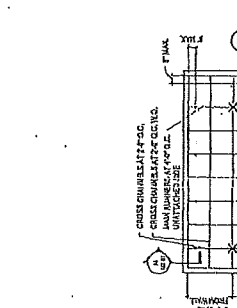

5. TYP. SECT. AT SUSP. TILE CEILING
3'-0" X 3'-0"

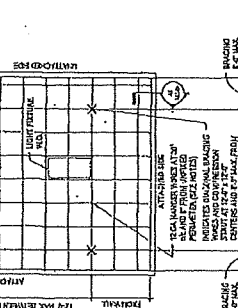

6. TYP. SECT. AT SUSP. TILE CEILING
3'-0" X 3'-0"

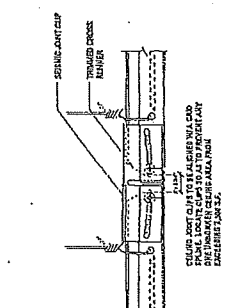

7. TYP. SECT. AT SUSP. TILE CEILING
3'-0" X 3'-0"

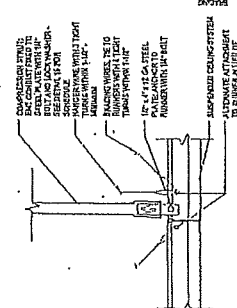

8. TYP. SECT. AT SUSP. TILE CEILING
3'-0" X 3'-0"

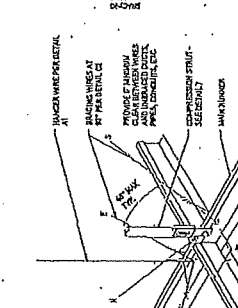

9. TYP. SECT. AT SUSP. TILE CEILING
3'-0" X 3'-0"

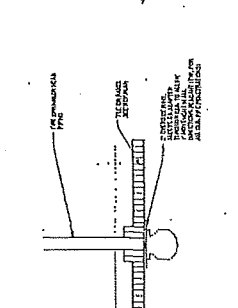

10. TYP. SECT. AT SUSP. TILE CEILING
3'-0" X 3'-0"

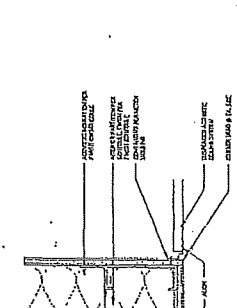

11. TYP. SECT. AT SUSP. TILE CEILING
3'-0" X 3'-0"

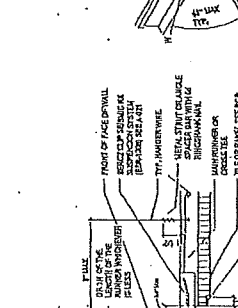

12. TYP. SECT. AT SUSP. TILE CEILING
3'-0" X 3'-0"

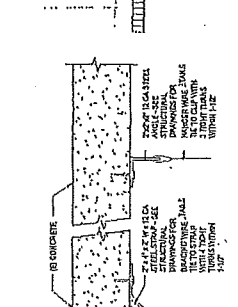

13. TYP. SECT. AT SUSP. TILE CEILING
3'-0" X 3'-0"

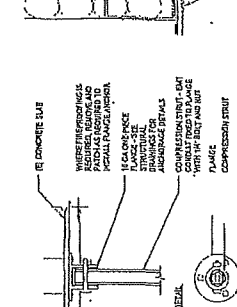

14. TYP. SECT. AT SUSP. TILE CEILING
3'-0" X 3'-0"

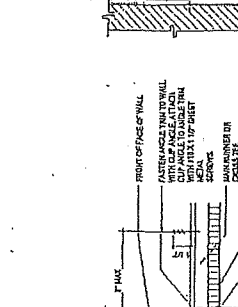

15. TYP. SECT. AT SUSP. TILE CEILING
3'-0" X 3'-0"

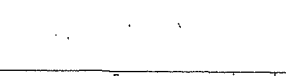

16. TYP. SECT. AT SUSP. TILE CEILING
3'-0" X 3'-0"

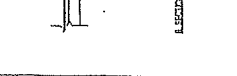

17. TYP. SECT. AT SUSP. TILE CEILING
3'-0" X 3'-0"

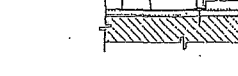

18. TYP. SECT. AT SUSP. TILE CEILING
3'-0" X 3'-0"

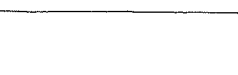

19. TYP. SECT. AT SUSP. TILE CEILING
3'-0" X 3'-0"



20. TYP. SECT. AT SUSP. TILE CEILING
3'-0" X 3'-0"

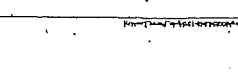

21. TYP. SECT. AT SUSP. TILE CEILING
3'-0" X 3'-0"

**PERKINS
+ WILL**

101 HYDE STREET
SAN FRANCISCO, CA 94102
TEL: 415.774.2900
WWW.PWK.COM

CONSULTANTS
FOR ARCHITECTURAL
SERVICES



REGISTERED

101 HYDE STREET
MUNICIPAL BUILDING
SAN FRANCISCO, CA 94102



LA CODINA
2045 CALIFORNIA STREET
SAN FRANCISCO, CA 94115

ISSUED FOR PRICING SET MAY 29, 2018



DATE SHEET

NO.	DATE	DESCRIPTION
1	05/29/18	ISSUED FOR PRICING SET
2		
3		
4		
5		

INTERIOR PARTITION
TYPE CHARTS

SHEET NUMBER

A61-01

DATE: 05/29/18

**PARTITION TYPES
GENERAL NOTES**

1. PARTITION TYPES SHOWN ARE BASED ON THE ASSUMPTIONS LISTED BELOW. THE PARTITION TYPES SHOWN ARE BASED ON THE ASSUMPTIONS LISTED BELOW.
2. PARTITION TYPES SHOWN ARE BASED ON THE ASSUMPTIONS LISTED BELOW. THE PARTITION TYPES SHOWN ARE BASED ON THE ASSUMPTIONS LISTED BELOW.
3. PARTITION TYPES SHOWN ARE BASED ON THE ASSUMPTIONS LISTED BELOW. THE PARTITION TYPES SHOWN ARE BASED ON THE ASSUMPTIONS LISTED BELOW.
4. PARTITION TYPES SHOWN ARE BASED ON THE ASSUMPTIONS LISTED BELOW. THE PARTITION TYPES SHOWN ARE BASED ON THE ASSUMPTIONS LISTED BELOW.
5. PARTITION TYPES SHOWN ARE BASED ON THE ASSUMPTIONS LISTED BELOW. THE PARTITION TYPES SHOWN ARE BASED ON THE ASSUMPTIONS LISTED BELOW.
6. PARTITION TYPES SHOWN ARE BASED ON THE ASSUMPTIONS LISTED BELOW. THE PARTITION TYPES SHOWN ARE BASED ON THE ASSUMPTIONS LISTED BELOW.
7. PARTITION TYPES SHOWN ARE BASED ON THE ASSUMPTIONS LISTED BELOW. THE PARTITION TYPES SHOWN ARE BASED ON THE ASSUMPTIONS LISTED BELOW.
8. PARTITION TYPES SHOWN ARE BASED ON THE ASSUMPTIONS LISTED BELOW. THE PARTITION TYPES SHOWN ARE BASED ON THE ASSUMPTIONS LISTED BELOW.
9. PARTITION TYPES SHOWN ARE BASED ON THE ASSUMPTIONS LISTED BELOW. THE PARTITION TYPES SHOWN ARE BASED ON THE ASSUMPTIONS LISTED BELOW.
10. PARTITION TYPES SHOWN ARE BASED ON THE ASSUMPTIONS LISTED BELOW. THE PARTITION TYPES SHOWN ARE BASED ON THE ASSUMPTIONS LISTED BELOW.
11. PARTITION TYPES SHOWN ARE BASED ON THE ASSUMPTIONS LISTED BELOW. THE PARTITION TYPES SHOWN ARE BASED ON THE ASSUMPTIONS LISTED BELOW.
12. PARTITION TYPES SHOWN ARE BASED ON THE ASSUMPTIONS LISTED BELOW. THE PARTITION TYPES SHOWN ARE BASED ON THE ASSUMPTIONS LISTED BELOW.
13. PARTITION TYPES SHOWN ARE BASED ON THE ASSUMPTIONS LISTED BELOW. THE PARTITION TYPES SHOWN ARE BASED ON THE ASSUMPTIONS LISTED BELOW.
14. PARTITION TYPES SHOWN ARE BASED ON THE ASSUMPTIONS LISTED BELOW. THE PARTITION TYPES SHOWN ARE BASED ON THE ASSUMPTIONS LISTED BELOW.
15. PARTITION TYPES SHOWN ARE BASED ON THE ASSUMPTIONS LISTED BELOW. THE PARTITION TYPES SHOWN ARE BASED ON THE ASSUMPTIONS LISTED BELOW.
16. PARTITION TYPES SHOWN ARE BASED ON THE ASSUMPTIONS LISTED BELOW. THE PARTITION TYPES SHOWN ARE BASED ON THE ASSUMPTIONS LISTED BELOW.
17. PARTITION TYPES SHOWN ARE BASED ON THE ASSUMPTIONS LISTED BELOW. THE PARTITION TYPES SHOWN ARE BASED ON THE ASSUMPTIONS LISTED BELOW.
18. PARTITION TYPES SHOWN ARE BASED ON THE ASSUMPTIONS LISTED BELOW. THE PARTITION TYPES SHOWN ARE BASED ON THE ASSUMPTIONS LISTED BELOW.
19. PARTITION TYPES SHOWN ARE BASED ON THE ASSUMPTIONS LISTED BELOW. THE PARTITION TYPES SHOWN ARE BASED ON THE ASSUMPTIONS LISTED BELOW.
20. PARTITION TYPES SHOWN ARE BASED ON THE ASSUMPTIONS LISTED BELOW. THE PARTITION TYPES SHOWN ARE BASED ON THE ASSUMPTIONS LISTED BELOW.



NO.	DESCRIPTION	THICKNESS	UNIT	AREA	QUANTITY	PRICE	TOTAL
1	1/2" Gypsum Board	1/2"	SF	100	100	1.00	100
2	1/2" Gypsum Board	1/2"	SF	100	100	1.00	100
3	1/2" Gypsum Board	1/2"	SF	100	100	1.00	100
4	1/2" Gypsum Board	1/2"	SF	100	100	1.00	100
5	1/2" Gypsum Board	1/2"	SF	100	100	1.00	100
6	1/2" Gypsum Board	1/2"	SF	100	100	1.00	100
7	1/2" Gypsum Board	1/2"	SF	100	100	1.00	100
8	1/2" Gypsum Board	1/2"	SF	100	100	1.00	100
9	1/2" Gypsum Board	1/2"	SF	100	100	1.00	100
10	1/2" Gypsum Board	1/2"	SF	100	100	1.00	100
11	1/2" Gypsum Board	1/2"	SF	100	100	1.00	100
12	1/2" Gypsum Board	1/2"	SF	100	100	1.00	100
13	1/2" Gypsum Board	1/2"	SF	100	100	1.00	100
14	1/2" Gypsum Board	1/2"	SF	100	100	1.00	100
15	1/2" Gypsum Board	1/2"	SF	100	100	1.00	100
16	1/2" Gypsum Board	1/2"	SF	100	100	1.00	100
17	1/2" Gypsum Board	1/2"	SF	100	100	1.00	100
18	1/2" Gypsum Board	1/2"	SF	100	100	1.00	100
19	1/2" Gypsum Board	1/2"	SF	100	100	1.00	100
20	1/2" Gypsum Board	1/2"	SF	100	100	1.00	100



NO.	DESCRIPTION	THICKNESS	UNIT	AREA	QUANTITY	PRICE	TOTAL
1	1/2" Gypsum Board	1/2"	SF	100	100	1.00	100
2	1/2" Gypsum Board	1/2"	SF	100	100	1.00	100
3	1/2" Gypsum Board	1/2"	SF	100	100	1.00	100
4	1/2" Gypsum Board	1/2"	SF	100	100	1.00	100
5	1/2" Gypsum Board	1/2"	SF	100	100	1.00	100
6	1/2" Gypsum Board	1/2"	SF	100	100	1.00	100
7	1/2" Gypsum Board	1/2"	SF	100	100	1.00	100
8	1/2" Gypsum Board	1/2"	SF	100	100	1.00	100
9	1/2" Gypsum Board	1/2"	SF	100	100	1.00	100
10	1/2" Gypsum Board	1/2"	SF	100	100	1.00	100
11	1/2" Gypsum Board	1/2"	SF	100	100	1.00	100
12	1/2" Gypsum Board	1/2"	SF	100	100	1.00	100
13	1/2" Gypsum Board	1/2"	SF	100	100	1.00	100
14	1/2" Gypsum Board	1/2"	SF	100	100	1.00	100
15	1/2" Gypsum Board	1/2"	SF	100	100	1.00	100
16	1/2" Gypsum Board	1/2"	SF	100	100	1.00	100
17	1/2" Gypsum Board	1/2"	SF	100	100	1.00	100
18	1/2" Gypsum Board	1/2"	SF	100	100	1.00	100
19	1/2" Gypsum Board	1/2"	SF	100	100	1.00	100
20	1/2" Gypsum Board	1/2"	SF	100	100	1.00	100

D TYPE
1/2" x 1/2"

A TYPE
1/2" x 1/2"

LA COCCINA

SAN FRANCISCO, CA

SHEET SCHEDULE	
FS-0	COVER PAGE
FS-1	FOOD SERVICE PLAN
FS-1.1	EQUIPMENT SCHEDULE
FS-1.2	EQUIPMENT SCHEDULE
FS-2	ELECTRICAL PLAN
FS-3	PLUMBING PLAN
FS-6	HOOD DRAWING
FS-6.1	HOOD DRAWING
FS-6.2	HOOD DRAWING
FS-6.3	HOOD DRAWING
FS-6.4	HOOD DRAWING
FS-6.5	HOOD DRAWING
FS-6.6	HOOD DRAWING
FS-6.7	HOOD DRAWING
FS-6.8	HOOD DRAWING
FS-6.9	HOOD DRAWING
FS-6.10	HOOD DRAWING
FS-6.11	HOOD DRAWING
FS-6.12	HOOD DRAWING
FS-6.13	HOOD DRAWING

VENTILATION NOTES:

1. WHEREAS A FRESH EXHAUSTION IS LOCATED AT AN INDOOR SPACE TO EXHAUST AIR, THE EXHAUST SYSTEM SHALL BE DESIGNED TO EXHAUST AIR TO THE OUTSIDE AIR AT A MINIMUM OF 100 FPM. THE EXHAUST SYSTEM SHALL BE DESIGNED TO EXHAUST AIR TO THE OUTSIDE AIR AT A MINIMUM OF 100 FPM.
2. THE EXHAUST SYSTEM SHALL BE DESIGNED TO EXHAUST AIR TO THE OUTSIDE AIR AT A MINIMUM OF 100 FPM.
3. THE EXHAUST SYSTEM SHALL BE DESIGNED TO EXHAUST AIR TO THE OUTSIDE AIR AT A MINIMUM OF 100 FPM.
4. THE EXHAUST SYSTEM SHALL BE DESIGNED TO EXHAUST AIR TO THE OUTSIDE AIR AT A MINIMUM OF 100 FPM.
5. THE EXHAUST SYSTEM SHALL BE DESIGNED TO EXHAUST AIR TO THE OUTSIDE AIR AT A MINIMUM OF 100 FPM.
6. THE EXHAUST SYSTEM SHALL BE DESIGNED TO EXHAUST AIR TO THE OUTSIDE AIR AT A MINIMUM OF 100 FPM.
7. THE EXHAUST SYSTEM SHALL BE DESIGNED TO EXHAUST AIR TO THE OUTSIDE AIR AT A MINIMUM OF 100 FPM.
8. THE EXHAUST SYSTEM SHALL BE DESIGNED TO EXHAUST AIR TO THE OUTSIDE AIR AT A MINIMUM OF 100 FPM.
9. THE EXHAUST SYSTEM SHALL BE DESIGNED TO EXHAUST AIR TO THE OUTSIDE AIR AT A MINIMUM OF 100 FPM.
10. THE EXHAUST SYSTEM SHALL BE DESIGNED TO EXHAUST AIR TO THE OUTSIDE AIR AT A MINIMUM OF 100 FPM.

FIRE SYSTEM NOTES:

1. FIRE EXTINGUISHING SYSTEMS SHALL BE DESIGNED TO EXTINGUISH FIRE IN ALL AREAS WHERE THERE IS A RISK OF FIRE.
2. FIRE EXTINGUISHING SYSTEMS SHALL BE DESIGNED TO EXTINGUISH FIRE IN ALL AREAS WHERE THERE IS A RISK OF FIRE.
3. FIRE EXTINGUISHING SYSTEMS SHALL BE DESIGNED TO EXTINGUISH FIRE IN ALL AREAS WHERE THERE IS A RISK OF FIRE.
4. FIRE EXTINGUISHING SYSTEMS SHALL BE DESIGNED TO EXTINGUISH FIRE IN ALL AREAS WHERE THERE IS A RISK OF FIRE.
5. FIRE EXTINGUISHING SYSTEMS SHALL BE DESIGNED TO EXTINGUISH FIRE IN ALL AREAS WHERE THERE IS A RISK OF FIRE.
6. FIRE EXTINGUISHING SYSTEMS SHALL BE DESIGNED TO EXTINGUISH FIRE IN ALL AREAS WHERE THERE IS A RISK OF FIRE.
7. FIRE EXTINGUISHING SYSTEMS SHALL BE DESIGNED TO EXTINGUISH FIRE IN ALL AREAS WHERE THERE IS A RISK OF FIRE.
8. FIRE EXTINGUISHING SYSTEMS SHALL BE DESIGNED TO EXTINGUISH FIRE IN ALL AREAS WHERE THERE IS A RISK OF FIRE.
9. FIRE EXTINGUISHING SYSTEMS SHALL BE DESIGNED TO EXTINGUISH FIRE IN ALL AREAS WHERE THERE IS A RISK OF FIRE.
10. FIRE EXTINGUISHING SYSTEMS SHALL BE DESIGNED TO EXTINGUISH FIRE IN ALL AREAS WHERE THERE IS A RISK OF FIRE.

GENERAL CONTRACTOR NOTES:

1. THE GENERAL CONTRACTOR SHALL BE RESPONSIBLE FOR OBTAINING ALL NECESSARY PERMITS AND APPROVALS FROM THE APPLICABLE AGENCIES.
2. THE GENERAL CONTRACTOR SHALL BE RESPONSIBLE FOR OBTAINING ALL NECESSARY PERMITS AND APPROVALS FROM THE APPLICABLE AGENCIES.
3. THE GENERAL CONTRACTOR SHALL BE RESPONSIBLE FOR OBTAINING ALL NECESSARY PERMITS AND APPROVALS FROM THE APPLICABLE AGENCIES.
4. THE GENERAL CONTRACTOR SHALL BE RESPONSIBLE FOR OBTAINING ALL NECESSARY PERMITS AND APPROVALS FROM THE APPLICABLE AGENCIES.
5. THE GENERAL CONTRACTOR SHALL BE RESPONSIBLE FOR OBTAINING ALL NECESSARY PERMITS AND APPROVALS FROM THE APPLICABLE AGENCIES.
6. THE GENERAL CONTRACTOR SHALL BE RESPONSIBLE FOR OBTAINING ALL NECESSARY PERMITS AND APPROVALS FROM THE APPLICABLE AGENCIES.
7. THE GENERAL CONTRACTOR SHALL BE RESPONSIBLE FOR OBTAINING ALL NECESSARY PERMITS AND APPROVALS FROM THE APPLICABLE AGENCIES.
8. THE GENERAL CONTRACTOR SHALL BE RESPONSIBLE FOR OBTAINING ALL NECESSARY PERMITS AND APPROVALS FROM THE APPLICABLE AGENCIES.
9. THE GENERAL CONTRACTOR SHALL BE RESPONSIBLE FOR OBTAINING ALL NECESSARY PERMITS AND APPROVALS FROM THE APPLICABLE AGENCIES.
10. THE GENERAL CONTRACTOR SHALL BE RESPONSIBLE FOR OBTAINING ALL NECESSARY PERMITS AND APPROVALS FROM THE APPLICABLE AGENCIES.

HEALTH DEPARTMENT NOTES:

1. THE HEALTH DEPARTMENT SHALL BE NOTIFIED OF ALL CHANGES TO THE PROJECT THAT MAY AFFECT THE HEALTH AND SAFETY OF THE PUBLIC.
2. THE HEALTH DEPARTMENT SHALL BE NOTIFIED OF ALL CHANGES TO THE PROJECT THAT MAY AFFECT THE HEALTH AND SAFETY OF THE PUBLIC.
3. THE HEALTH DEPARTMENT SHALL BE NOTIFIED OF ALL CHANGES TO THE PROJECT THAT MAY AFFECT THE HEALTH AND SAFETY OF THE PUBLIC.
4. THE HEALTH DEPARTMENT SHALL BE NOTIFIED OF ALL CHANGES TO THE PROJECT THAT MAY AFFECT THE HEALTH AND SAFETY OF THE PUBLIC.
5. THE HEALTH DEPARTMENT SHALL BE NOTIFIED OF ALL CHANGES TO THE PROJECT THAT MAY AFFECT THE HEALTH AND SAFETY OF THE PUBLIC.
6. THE HEALTH DEPARTMENT SHALL BE NOTIFIED OF ALL CHANGES TO THE PROJECT THAT MAY AFFECT THE HEALTH AND SAFETY OF THE PUBLIC.
7. THE HEALTH DEPARTMENT SHALL BE NOTIFIED OF ALL CHANGES TO THE PROJECT THAT MAY AFFECT THE HEALTH AND SAFETY OF THE PUBLIC.
8. THE HEALTH DEPARTMENT SHALL BE NOTIFIED OF ALL CHANGES TO THE PROJECT THAT MAY AFFECT THE HEALTH AND SAFETY OF THE PUBLIC.
9. THE HEALTH DEPARTMENT SHALL BE NOTIFIED OF ALL CHANGES TO THE PROJECT THAT MAY AFFECT THE HEALTH AND SAFETY OF THE PUBLIC.
10. THE HEALTH DEPARTMENT SHALL BE NOTIFIED OF ALL CHANGES TO THE PROJECT THAT MAY AFFECT THE HEALTH AND SAFETY OF THE PUBLIC.

ABBREVIATIONS

FINISH FLOOR	FINISH FLOOR	FINISH FLOOR	FINISH FLOOR	FINISH FLOOR	FINISH FLOOR	FINISH FLOOR	FINISH FLOOR	FINISH FLOOR	FINISH FLOOR
CONTRACTOR	CONTRACTOR	CONTRACTOR	CONTRACTOR	CONTRACTOR	CONTRACTOR	CONTRACTOR	CONTRACTOR	CONTRACTOR	CONTRACTOR
CONTRACTOR	CONTRACTOR	CONTRACTOR	CONTRACTOR	CONTRACTOR	CONTRACTOR	CONTRACTOR	CONTRACTOR	CONTRACTOR	CONTRACTOR
CONTRACTOR	CONTRACTOR	CONTRACTOR	CONTRACTOR	CONTRACTOR	CONTRACTOR	CONTRACTOR	CONTRACTOR	CONTRACTOR	CONTRACTOR
CONTRACTOR	CONTRACTOR	CONTRACTOR	CONTRACTOR	CONTRACTOR	CONTRACTOR	CONTRACTOR	CONTRACTOR	CONTRACTOR	CONTRACTOR
CONTRACTOR	CONTRACTOR	CONTRACTOR	CONTRACTOR	CONTRACTOR	CONTRACTOR	CONTRACTOR	CONTRACTOR	CONTRACTOR	CONTRACTOR
CONTRACTOR	CONTRACTOR	CONTRACTOR	CONTRACTOR	CONTRACTOR	CONTRACTOR	CONTRACTOR	CONTRACTOR	CONTRACTOR	CONTRACTOR
CONTRACTOR	CONTRACTOR	CONTRACTOR	CONTRACTOR	CONTRACTOR	CONTRACTOR	CONTRACTOR	CONTRACTOR	CONTRACTOR	CONTRACTOR
CONTRACTOR	CONTRACTOR	CONTRACTOR	CONTRACTOR	CONTRACTOR	CONTRACTOR	CONTRACTOR	CONTRACTOR	CONTRACTOR	CONTRACTOR
CONTRACTOR	CONTRACTOR	CONTRACTOR	CONTRACTOR	CONTRACTOR	CONTRACTOR	CONTRACTOR	CONTRACTOR	CONTRACTOR	CONTRACTOR

DISCLAIMER

THESE PLANS ARE NOT PROVIDED AS A RESULT OF AN AGREEMENT FOR THOSE PURPOSES. THESE PLANS ARE PROVIDED AS A RESULT OF AN AGREEMENT FOR THOSE PURPOSES. THESE PLANS ARE PROVIDED AS A RESULT OF AN AGREEMENT FOR THOSE PURPOSES. THESE PLANS ARE PROVIDED AS A RESULT OF AN AGREEMENT FOR THOSE PURPOSES. THESE PLANS ARE PROVIDED AS A RESULT OF AN AGREEMENT FOR THOSE PURPOSES. THESE PLANS ARE PROVIDED AS A RESULT OF AN AGREEMENT FOR THOSE PURPOSES. THESE PLANS ARE PROVIDED AS A RESULT OF AN AGREEMENT FOR THOSE PURPOSES. THESE PLANS ARE PROVIDED AS A RESULT OF AN AGREEMENT FOR THOSE PURPOSES. THESE PLANS ARE PROVIDED AS A RESULT OF AN AGREEMENT FOR THOSE PURPOSES. THESE PLANS ARE PROVIDED AS A RESULT OF AN AGREEMENT FOR THOSE PURPOSES.

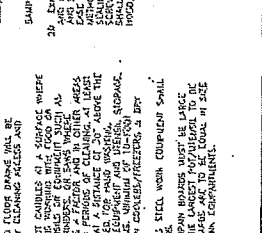
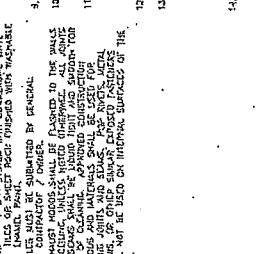
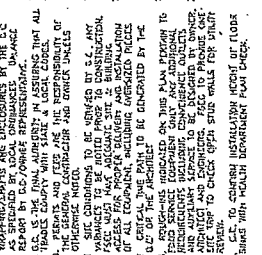
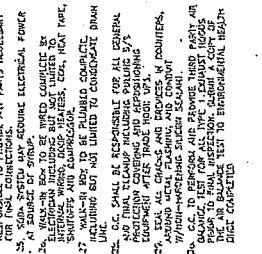
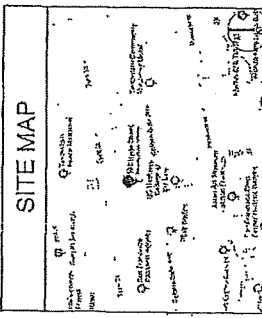

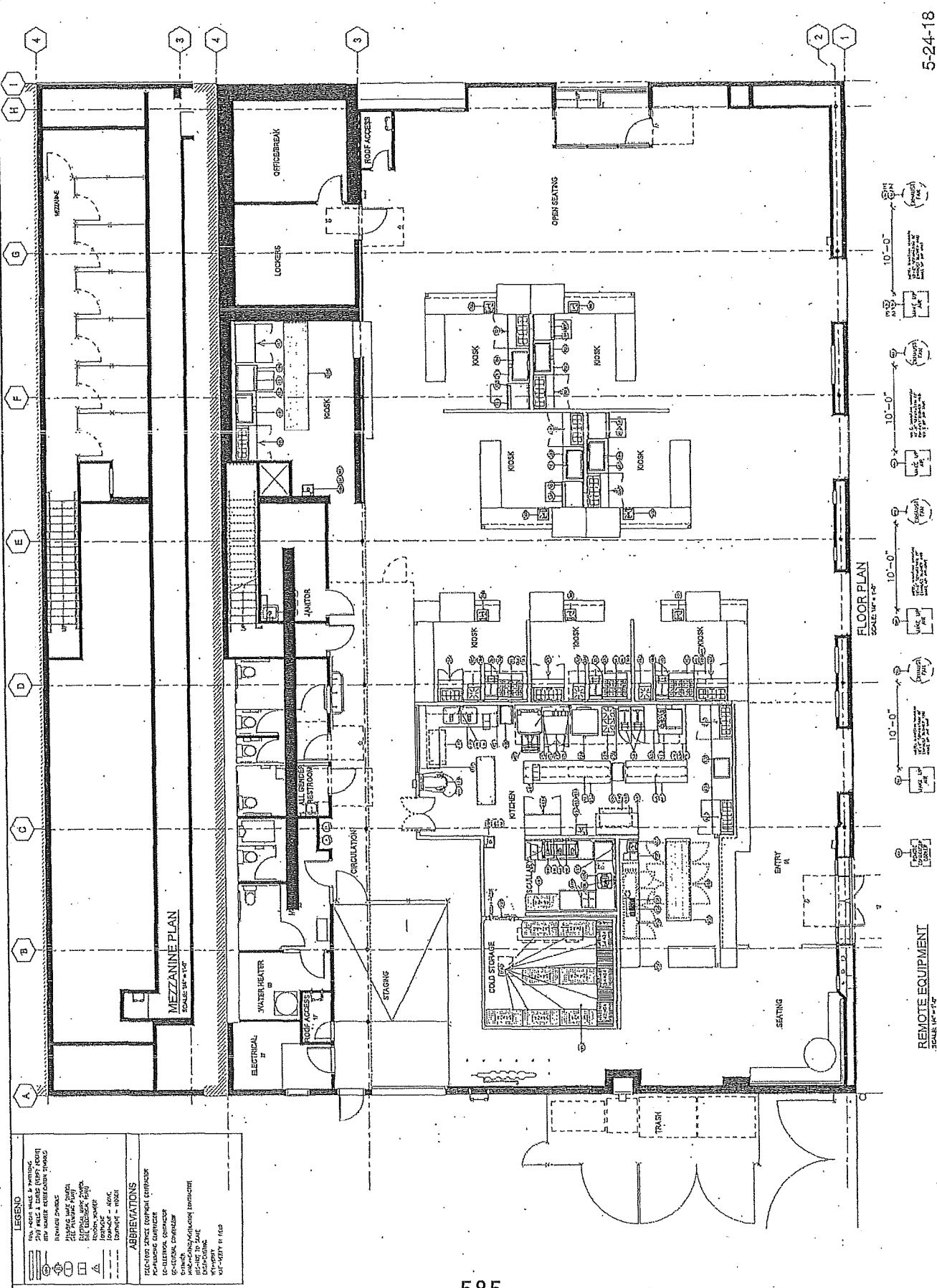

LEGEND

1/4" = 1'-0" MEZZANINE PLAN
 1/4" = 1'-0" FLOOR PLAN
 1/4" = 1'-0" REMOTE EQUIPMENT

ABBREVIATIONS

ROOF ACCESS
 ELECTRICAL
 WATER HEATER
 CIRCULATION
 STAGING
 RESTROOM
 JANITOR
 KITCHEN
 COLD STORAGE
 SEATING
 ENTRY
 OPEN SEATING
 OFFICE/BREAK
 LOCKERS
 MEZZANINE

5-24-18

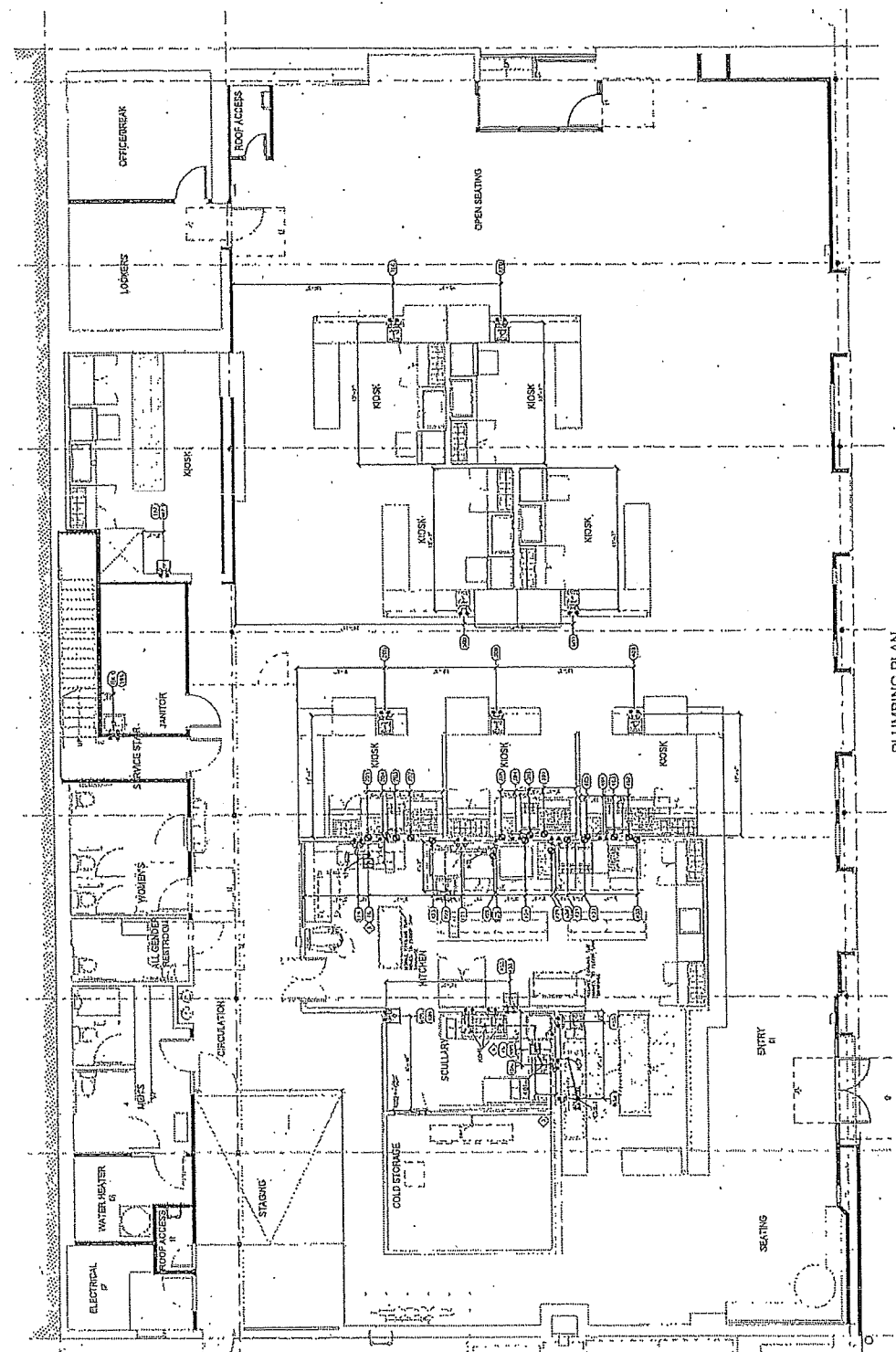

PLUMBING PLAN
 SCALE: 1/8" = 1'-0"

- EXISTING UNRECORDED**
- ◆ Existing floor joists, joists, and other structural members.
 - ◆ Existing walls, columns, and other structural members.
 - ◆ Existing mechanical, electrical, and plumbing systems.
 - ◆ Existing site conditions, including topography, utilities, and adjacent structures.
 - ◆ Existing site access, including streets, sidewalks, and parking areas.
 - ◆ Existing site easements, including utility easements and access easements.
 - ◆ Existing site setbacks, including front, side, and rear setbacks.
 - ◆ Existing site zoning, including zoning districts and special use permits.
 - ◆ Existing site environmental conditions, including wetlands, floodplains, and trees.
 - ◆ Existing site historical resources, including archaeological sites and historic structures.

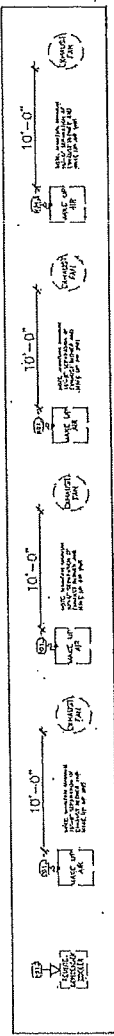

- PLUMBING LEGEND**
- Cold Water
 - Hot Water
 - Sewer
 - Gas
 - Vent
 - Exhaust
 - Condensate
 - Other

NOTE: DIMENSIONS ON UTILITY PAGES ARE PROVIDED FROM FINISHED WALLS. ALL CONSTRUCTION IS COMPLETE. UTILITIES & ROUGH EXISTING CONNECTIONS, WHEREVER POSSIBLE.

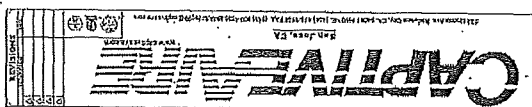

DATE: 10/24/01
 DRAWN BY: [Name]
 CHECKED BY: [Name]
 MASTER DRAWING
 SHEET NO. [Number]

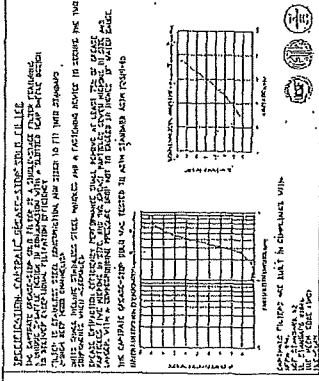

EXPLANATION: CAPTIVE CLEAN-AIR™ HOOD SYSTEM
 The CAPTIVE Clean-Air™ Hood System is a revolutionary new hood system designed to provide superior air cleaning and capture efficiency. It features a unique design that allows for the capture of grease and odors before they can reach the filters. This results in longer filter life and reduced maintenance costs. The system is also designed to be quiet and energy efficient.

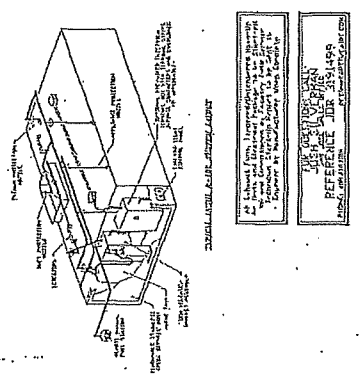

MECHANICAL AIR BALANCE

Item	Description	CFM
1	HOOD AIA VIA PFP	9,150 CFM
2	HOOD AIA VIA DIFFUSER	7,600 CFM
3	REMAINDER FROM HVAC	1,350 CFM
TOTAL HOOD EXHAUST: 18,100 CFM		

MECHANICAL AIR BALANCE

Item	Description	CFM
1	HOOD AIA VIA PFP	9,150 CFM
2	HOOD AIA VIA DIFFUSER	7,600 CFM
3	REMAINDER FROM HVAC	1,350 CFM

HOOD REQUIREMENTS - MECHANICAL

Item	Location	Area (sq ft)	Height (ft)	CFM
1	Line 1	100	10	1000
2	Line 2	150	10	1500
3	Line 3	200	10	2000
4	Line 4	250	10	2500
5	Line 5	300	10	3000
6	Line 6	350	10	3500
7	Line 7	400	10	4000
8	Line 8	450	10	4500
9	Line 9	500	10	5000
10	Line 10	550	10	5500
11	Line 11	600	10	6000
12	Line 12	650	10	6500
13	Line 13	700	10	7000
14	Line 14	750	10	7500
15	Line 15	800	10	8000
16	Line 16	850	10	8500
17	Line 17	900	10	9000
18	Line 18	950	10	9500
19	Line 19	1000	10	10000
20	Line 20	1050	10	10500
21	Line 21	1100	10	11000
22	Line 22	1150	10	11500
23	Line 23	1200	10	12000
24	Line 24	1250	10	12500
25	Line 25	1300	10	13000
26	Line 26	1350	10	13500
27	Line 27	1400	10	14000
28	Line 28	1450	10	14500
29	Line 29	1500	10	15000
30	Line 30	1550	10	15500
31	Line 31	1600	10	16000
32	Line 32	1650	10	16500
33	Line 33	1700	10	17000
34	Line 34	1750	10	17500
35	Line 35	1800	10	18000
36	Line 36	1850	10	18500
37	Line 37	1900	10	19000
38	Line 38	1950	10	19500
39	Line 39	2000	10	20000
40	Line 40	2050	10	20500
41	Line 41	2100	10	21000
42	Line 42	2150	10	21500
43	Line 43	2200	10	22000
44	Line 44	2250	10	22500
45	Line 45	2300	10	23000
46	Line 46	2350	10	23500
47	Line 47	2400	10	24000
48	Line 48	2450	10	24500
49	Line 49	2500	10	25000
50	Line 50	2550	10	25500
51	Line 51	2600	10	26000
52	Line 52	2650	10	26500
53	Line 53	2700	10	27000
54	Line 54	2750	10	27500
55	Line 55	2800	10	28000
56	Line 56	2850	10	28500
57	Line 57	2900	10	29000
58	Line 58	2950	10	29500
59	Line 59	3000	10	30000
60	Line 60	3050	10	30500
61	Line 61	3100	10	31000
62	Line 62	3150	10	31500
63	Line 63	3200	10	32000
64	Line 64	3250	10	32500
65	Line 65	3300	10	33000
66	Line 66	3350	10	33500
67	Line 67	3400	10	34000
68	Line 68	3450	10	34500
69	Line 69	3500	10	35000
70	Line 70	3550	10	35500
71	Line 71	3600	10	36000
72	Line 72	3650	10	36500
73	Line 73	3700	10	37000
74	Line 74	3750	10	37500
75	Line 75	3800	10	38000
76	Line 76	3850	10	38500
77	Line 77	3900	10	39000
78	Line 78	3950	10	39500
79	Line 79	4000	10	40000
80	Line 80	4050	10	40500
81	Line 81	4100	10	41000
82	Line 82	4150	10	41500
83	Line 83	4200	10	42000
84	Line 84	4250	10	42500
85	Line 85	4300	10	43000
86	Line 86	4350	10	43500
87	Line 87	4400	10	44000
88	Line 88	4450	10	44500
89	Line 89	4500	10	45000
90	Line 90	4550	10	45500
91	Line 91	4600	10	46000
92	Line 92	4650	10	46500
93	Line 93	4700	10	47000
94	Line 94	4750	10	47500
95	Line 95	4800	10	48000
96	Line 96	4850	10	48500
97	Line 97	4900	10	49000
98	Line 98	4950	10	49500
99	Line 99	5000	10	50000
100	Line 100	5050	10	50500

MECHANICAL AIR BALANCE

Item	Description	CFM
1	HOOD AIA VIA PFP	9,150 CFM
2	HOOD AIA VIA DIFFUSER	7,600 CFM
3	REMAINDER FROM HVAC	1,350 CFM

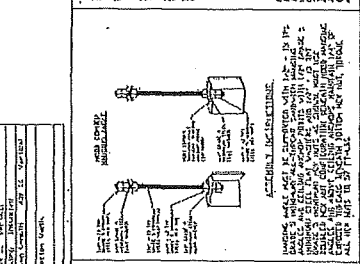
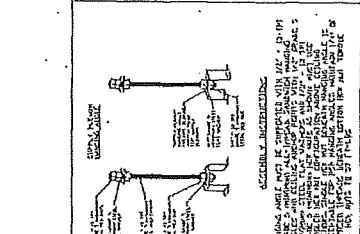

KITCHEN EXHAUST HOOD REQUIREMENTS

1. Hood shall be designed to capture 100% of the exhaust from the cooking equipment.
2. Hood shall be designed to capture 100% of the exhaust from the cooking equipment.
3. Hood shall be designed to capture 100% of the exhaust from the cooking equipment.
4. Hood shall be designed to capture 100% of the exhaust from the cooking equipment.
5. Hood shall be designed to capture 100% of the exhaust from the cooking equipment.
6. Hood shall be designed to capture 100% of the exhaust from the cooking equipment.
7. Hood shall be designed to capture 100% of the exhaust from the cooking equipment.
8. Hood shall be designed to capture 100% of the exhaust from the cooking equipment.
9. Hood shall be designed to capture 100% of the exhaust from the cooking equipment.
10. Hood shall be designed to capture 100% of the exhaust from the cooking equipment.
11. Hood shall be designed to capture 100% of the exhaust from the cooking equipment.
12. Hood shall be designed to capture 100% of the exhaust from the cooking equipment.
13. Hood shall be designed to capture 100% of the exhaust from the cooking equipment.
14. Hood shall be designed to capture 100% of the exhaust from the cooking equipment.
15. Hood shall be designed to capture 100% of the exhaust from the cooking equipment.
16. Hood shall be designed to capture 100% of the exhaust from the cooking equipment.
17. Hood shall be designed to capture 100% of the exhaust from the cooking equipment.
18. Hood shall be designed to capture 100% of the exhaust from the cooking equipment.
19. Hood shall be designed to capture 100% of the exhaust from the cooking equipment.
20. Hood shall be designed to capture 100% of the exhaust from the cooking equipment.

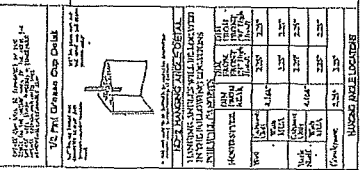
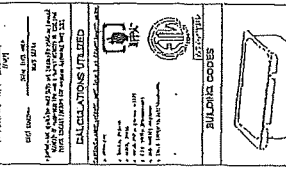
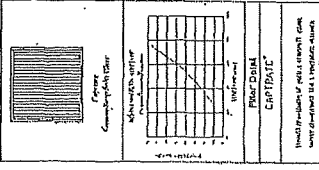

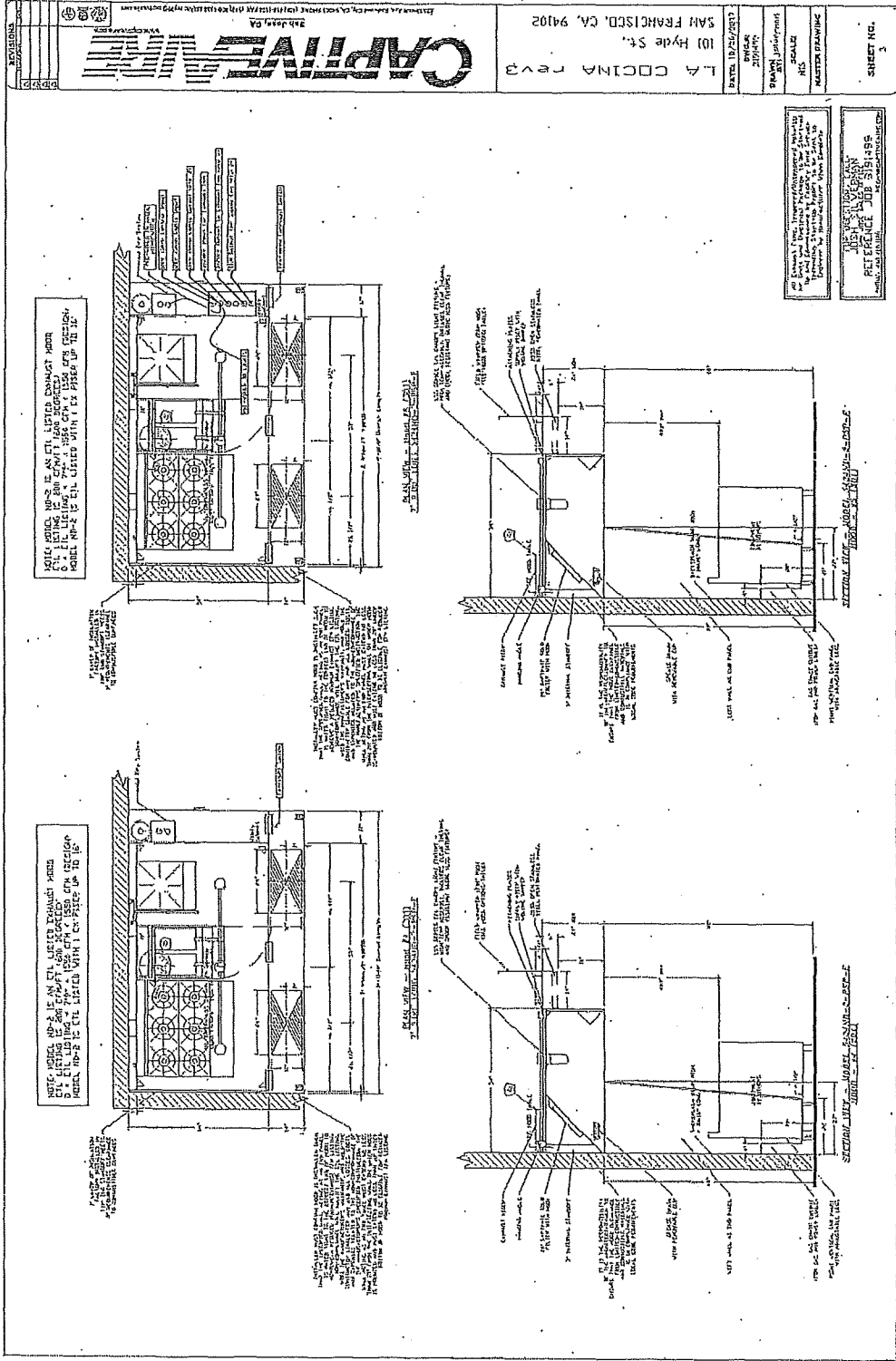

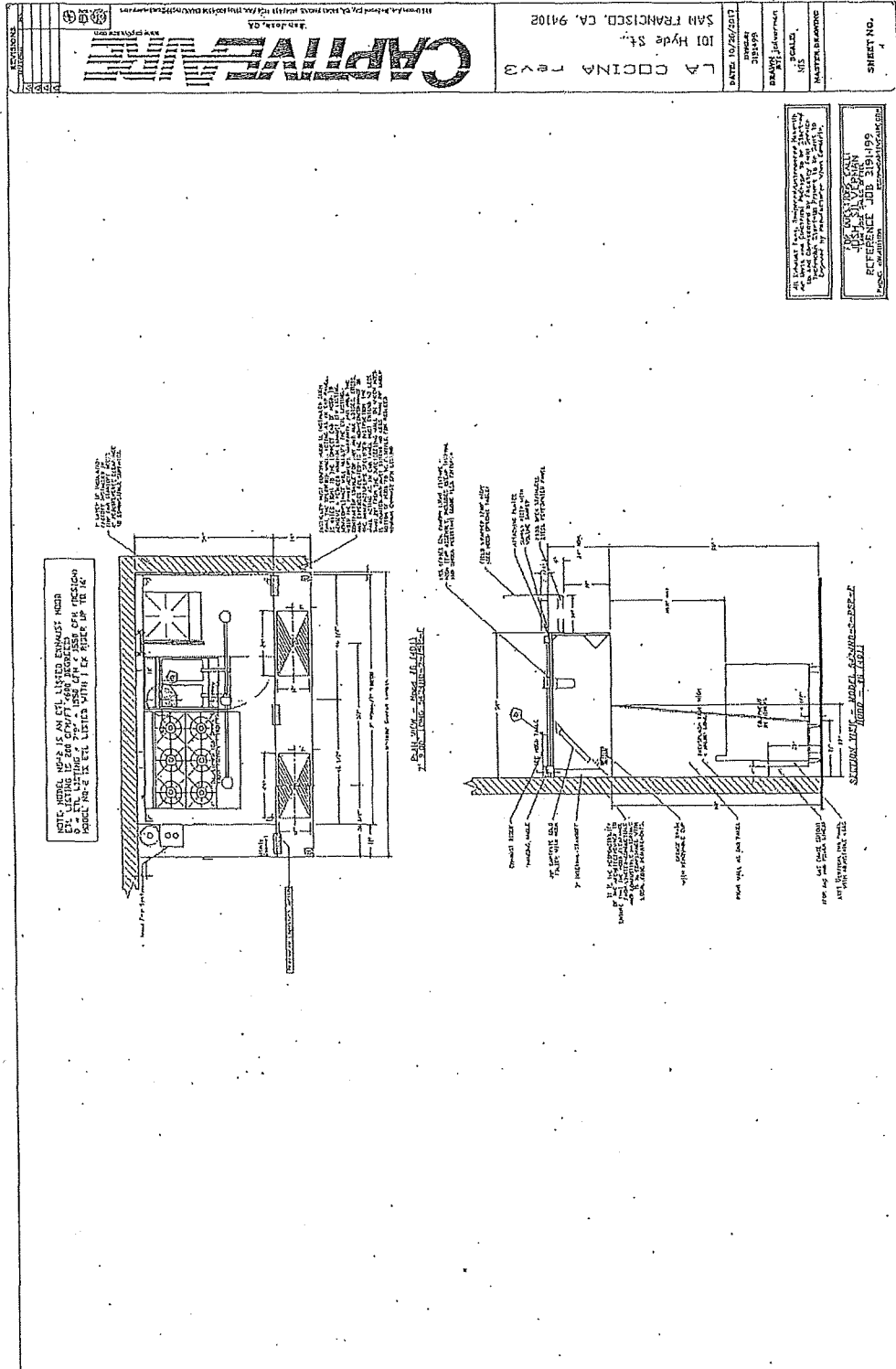

5-24-18

THIS DRAWING IS THE PROPERTY OF MFSDB. IT IS TO BE USED ONLY FOR THE PROJECT AND SITE SPECIFICALLY IDENTIFIED HEREON. IT IS NOT TO BE REPRODUCED, COPIED, OR TRANSMITTED IN ANY FORM OR BY ANY MEANS, ELECTRONIC OR MECHANICAL, INCLUDING PHOTOCOPYING, RECORDING, OR BY ANY INFORMATION STORAGE AND RETRIEVAL SYSTEM, WITHOUT THE WRITTEN PERMISSION OF MFSDB.

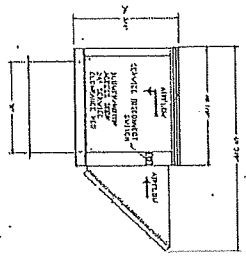
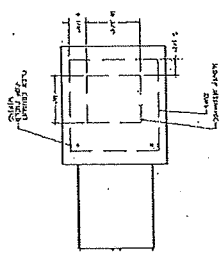

THIS DRAWING IS THE PROPERTY OF MFSDB. IT IS TO BE USED ONLY FOR THE PROJECT AND SITE SPECIFICALLY IDENTIFIED HEREON. IT IS NOT TO BE REPRODUCED, COPIED, OR TRANSMITTED IN ANY FORM OR BY ANY MEANS, ELECTRONIC OR MECHANICAL, INCLUDING PHOTOCOPYING, RECORDING, OR BY ANY INFORMATION STORAGE AND RETRIEVAL SYSTEM, WITHOUT THE WRITTEN PERMISSION OF MFSDB.

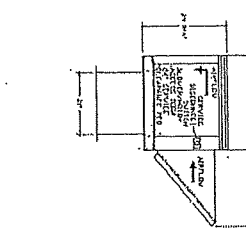
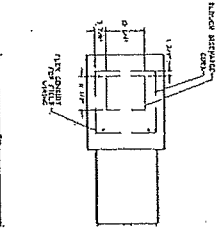

THIS DRAWING IS THE PROPERTY OF MFSDB. IT IS TO BE USED ONLY FOR THE PROJECT AND SITE SPECIFICALLY IDENTIFIED HEREON. IT IS NOT TO BE REPRODUCED, COPIED, OR TRANSMITTED IN ANY FORM OR BY ANY MEANS, ELECTRONIC OR MECHANICAL, INCLUDING PHOTOCOPYING, RECORDING, OR BY ANY INFORMATION STORAGE AND RETRIEVAL SYSTEM, WITHOUT THE WRITTEN PERMISSION OF MFSDB.

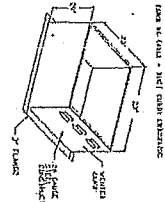
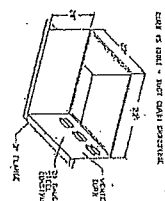
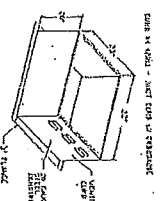
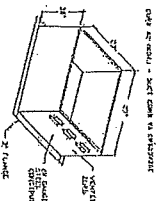
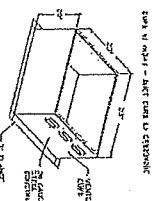

THIS DRAWING IS THE PROPERTY OF MFSDB. IT IS TO BE USED ONLY FOR THE PROJECT AND SITE SPECIFICALLY IDENTIFIED HEREON. IT IS NOT TO BE REPRODUCED, COPIED, OR TRANSMITTED IN ANY FORM OR BY ANY MEANS, ELECTRONIC OR MECHANICAL, INCLUDING PHOTOCOPYING, RECORDING, OR BY ANY INFORMATION STORAGE AND RETRIEVAL SYSTEM, WITHOUT THE WRITTEN PERMISSION OF MFSDB.

<p>LA COCINA 101 Hyde St., SAN FRANCISCO, CA, 94102</p>		<p>CAPTIVE AIR San Jose, CA</p>		<p>DATE: 10/26/2017 SHEET NO. 0</p>
--	--	--	--	---

5-24-18

<p>FOODSERVICE EQUIPMENT HOOD DRAWING</p>	<p>LA COCINA 101 HYDE ST SAN FRANCISCO, CA 94102</p>	<p>MFSDB Meyers Foodservice Design + Build</p>
---	--	--

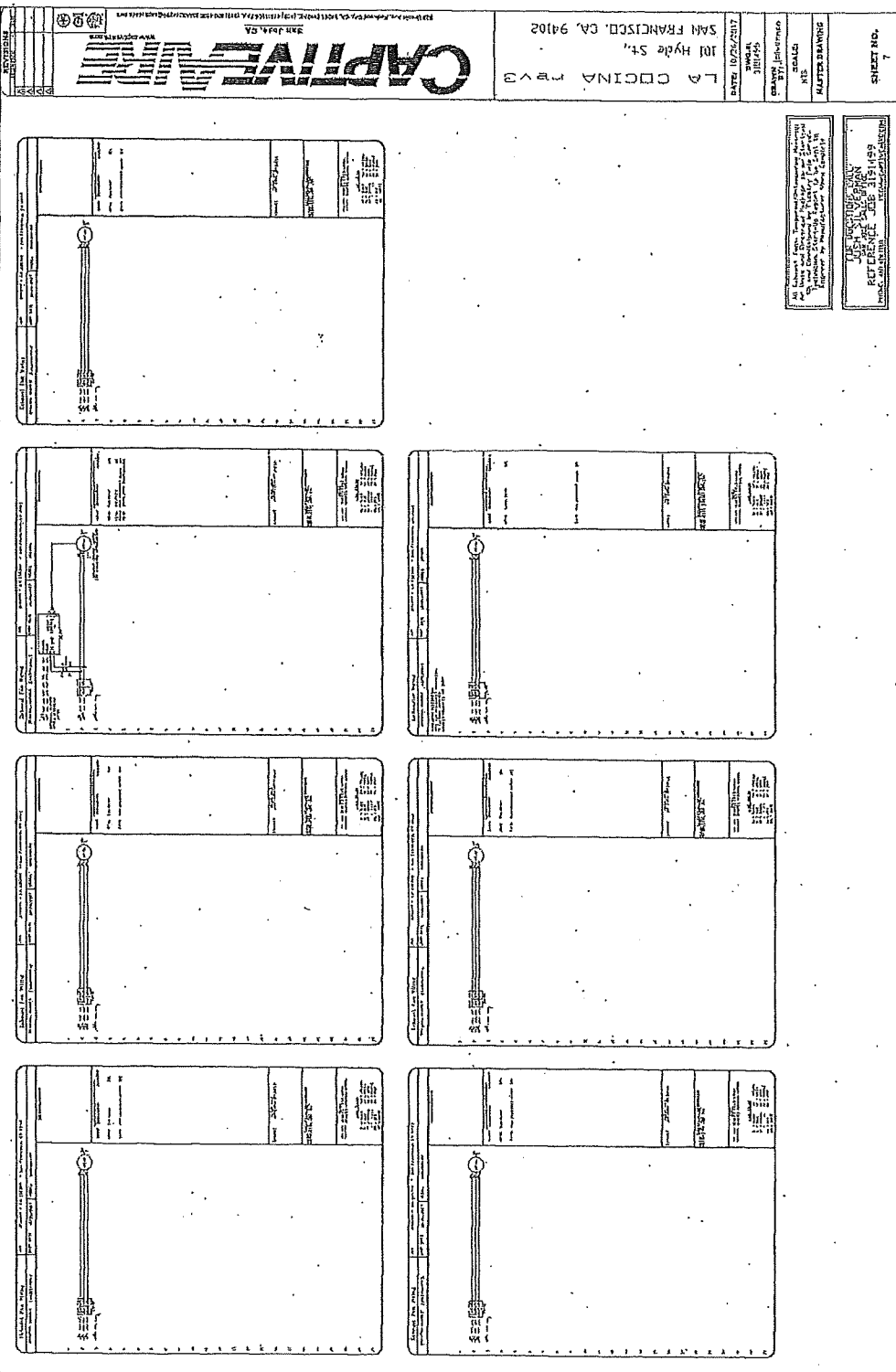

5-24-18

DATE: 10/26/2017	PROJECT: 2017-059	SHEET NO. 3
DRAWING: HOOD DRAWING	OWNER: LA COCINA REV3	PROJECT: 101 HYDE ST, SAN FRANCISCO, CA, 94102
DESIGNED BY: [Signature]	DATE: 10/26/2017	SCALE: 1/8" = 1'-0"
CHECKED BY: [Signature]	DATE: 10/26/2017	PROJECT: 101 HYDE ST, SAN FRANCISCO, CA, 94102



THIS DRAWING IS THE PROPERTY OF CAPTIVE MILITARY EQUIPMENT. IT IS TO BE USED ONLY FOR THE PROJECT AND SITE SPECIFICALLY IDENTIFIED HEREON. IT IS NOT TO BE REPRODUCED, COPIED, OR TRANSMITTED IN ANY FORM OR BY ANY MEANS, ELECTRONIC OR MECHANICAL, INCLUDING PHOTOCOPYING, RECORDING, OR BY ANY INFORMATION STORAGE AND RETRIEVAL SYSTEM, WITHOUT THE WRITTEN PERMISSION OF CAPTIVE MILITARY EQUIPMENT.

JAMES J. JAVAN
REFERENCE JOB #331499
EQUIPMENT

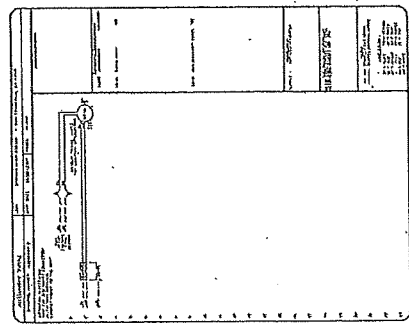
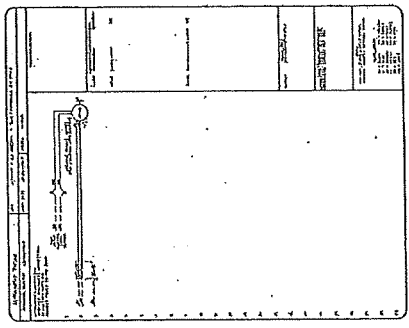
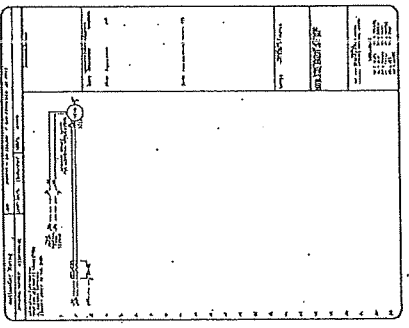

CAPTIVE
101 HYDE ST.
SAN FRANCISCO, CA, 94102

PROJECT INFORMATION
DATE: 02/27/17
DRAWN BY: [Name]
CHECKED BY: [Name]
SCALE: AS SHOWN
MASTER DRAWING

SHEET NO. 4
REFERENCE SHEETS FS-6.1, FS-6.2, FS-6.3, FS-6.4, FS-6.5, FS-6.6, FS-6.7, FS-6.9, FS-6.10, FS-6.11, FS-6.12, FS-6.13, FS-6.14, FS-6.15, FS-6.16, FS-6.17, FS-6.18, FS-6.19, FS-6.20, FS-6.21, FS-6.22, FS-6.23, FS-6.24, FS-6.25, FS-6.26, FS-6.27, FS-6.28, FS-6.29, FS-6.30, FS-6.31, FS-6.32, FS-6.33, FS-6.34, FS-6.35, FS-6.36, FS-6.37, FS-6.38, FS-6.39, FS-6.40, FS-6.41, FS-6.42, FS-6.43, FS-6.44, FS-6.45, FS-6.46, FS-6.47, FS-6.48, FS-6.49, FS-6.50, FS-6.51, FS-6.52, FS-6.53, FS-6.54, FS-6.55, FS-6.56, FS-6.57, FS-6.58, FS-6.59, FS-6.60, FS-6.61, FS-6.62, FS-6.63, FS-6.64, FS-6.65, FS-6.66, FS-6.67, FS-6.68, FS-6.69, FS-6.70, FS-6.71, FS-6.72, FS-6.73, FS-6.74, FS-6.75, FS-6.76, FS-6.77, FS-6.78, FS-6.79, FS-6.80, FS-6.81, FS-6.82, FS-6.83, FS-6.84, FS-6.85, FS-6.86, FS-6.87, FS-6.88, FS-6.89, FS-6.90, FS-6.91, FS-6.92, FS-6.93, FS-6.94, FS-6.95, FS-6.96, FS-6.97, FS-6.98, FS-6.99, FS-6.100

MECHANICAL NOTES
1. Hood shall be installed in accordance with the manufacturer's instructions.
2. Hood shall be supported by a minimum of 2 x 4 studs.
3. Hood shall be supported by a minimum of 2 x 4 studs.
4. Hood shall be supported by a minimum of 2 x 4 studs.
5. Hood shall be supported by a minimum of 2 x 4 studs.

ELECTRICAL PANEL
1. The electrical panel shall be installed in accordance with the manufacturer's instructions.
2. The electrical panel shall be installed in accordance with the manufacturer's instructions.
3. The electrical panel shall be installed in accordance with the manufacturer's instructions.

CONTROL DIAGRAM
1. The control diagram shall be installed in accordance with the manufacturer's instructions.
2. The control diagram shall be installed in accordance with the manufacturer's instructions.
3. The control diagram shall be installed in accordance with the manufacturer's instructions.

DUCT THERMOSTAT DETAIL
1. The duct thermostat shall be installed in accordance with the manufacturer's instructions.
2. The duct thermostat shall be installed in accordance with the manufacturer's instructions.
3. The duct thermostat shall be installed in accordance with the manufacturer's instructions.

DUCT THERMOSTAT DETAIL
1. The duct thermostat shall be installed in accordance with the manufacturer's instructions.
2. The duct thermostat shall be installed in accordance with the manufacturer's instructions.
3. The duct thermostat shall be installed in accordance with the manufacturer's instructions.

CAPTIVE
San Jose, CA
www.captivehvac.com

DATE: 05/24/18
DRAWN BY: JIM KAY
CHECKED BY: JIM KAY
SCALE: AS SHOWN
SHEET NO. 10

LA COCINA REV 3
101 Hyde St.,
SAN FRANCISCO, CA, 94102

SEE CAPTION FOR
JOB # 181899
REFERENCE JOB # 181899
DATE: 05/24/18

REVISIONS

NO.	DATE	DESCRIPTION
1		
2		
3		
4		
5		
6		
7		
8		
9		
10		

REVISIONS

NO.	DATE	DESCRIPTION
1		
2		
3		
4		
5		
6		
7		
8		
9		
10		

5-24-18

CAPTIVE
 SAN FRANCISCO, CA 94102
 101 HYDE ST
 SAN FRANCISCO, CA 94102

L A COCINA
 101 HYDE ST
 SAN FRANCISCO, CA 94102

PROJECT: LA COCINA
 DRAWN BY: M. J. [illegible]
 CHECKED BY: [illegible]
 DATE: 1/22/14

SHEET NO. 11

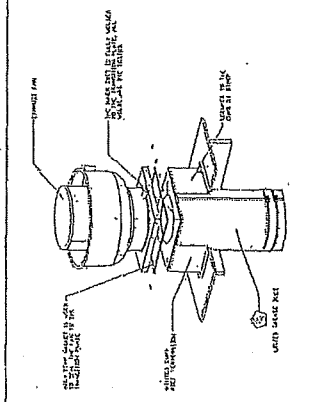

GREASE DUCT SPECIFICATIONS:
 PROVIDE GREASE DUCT EQUAL TO CAPTIVEAIR SYSTEMS MODEL "DM"
 ROUND 20 GAUGE 430 STAINLESS STEEL DOUBLE WALL. MODEL "DM"
 CONNECTIONS SEALED WITH 3M FIRE RESISTANT GLOUT PLUS. MODEL "DM"
 DOES NOT REQUIRE WELDING PROVIDING IT HAS BEEN INSTALLED PER
 THE MANUFACTURER'S INSTALLATION GUIDE.
 PROVIDE RATED ACCESS DOORS AT EVERY CHANGE IN DIRECTION AND EVERY 12' ON CENTER.
 PER MANUFACTURER'S LISTING MODEL "DM", HORIZONTAL RUNS LESS THAN 75 FT. CAN BE
 SLOPED 1/8" PER 12". HORIZONTAL RUNS MORE THAN 75 FT. CAN BE SLOPED 3/16" PER 12".
 DUCT SHOULD BE SLOPED AS MUCH AS POSSIBLE TO REDUCE THE CHANCE OF GREASE
 ACCUMULATION IN HORIZONTAL RUNS.

IF THE DUCT IS WITHIN 18 INCHES OF COMBUSTIBLE MATERIAL, PROVIDE UL-2281 LISTED
 DOUBLE WALL GREASE DUCT EQUAL TO CAPTIVEAIR SYSTEMS MODEL "DM", 26, 3R, DR 3Z,
 ROUND 20 GAUGE 430 STAINLESS INNER DUCT INSULATED WITH A 24 GAUGE 430 STAINLESS
 OUTER SHELL.

HYVAC DISTRIBUTION NOTE
 IT IS RECOMMENDED NOT TO INSTALL HIGH
 VOLTAGE LINE ON THESE DUCTS. IF THE LINE IS
 WITHIN 18 INCHES OF THE EXHAUST HOOD,
 PERFORATED DIFFUSERS ARE RECOMMENDED.

CUSTOMER APPROVAL TO MANUFACTURE:
 Approved by: _____
 Date: _____
 Name: _____
 Title: _____

VERIFY CEILING HEIGHT
 Before installation, verify the space between the duct and ceiling meets
 the minimum clearance requirements.

DUCT DIAMETER	DUCT LENGTH	DUCT WEIGHT (LBS)	DUCT WEIGHT (KGS)	DUCT WEIGHT (LBS) PER FOOT
3"	10'	10	4.5	1.0
3"	12'	12	5.4	1.2
3"	14'	14	6.3	1.4
3"	16'	16	7.2	1.6
3"	18'	18	8.1	1.8
3"	20'	20	9.0	2.0
3"	22'	22	9.9	2.2
3"	24'	24	10.8	2.4
3"	26'	26	11.7	2.6
3"	28'	28	12.6	2.8
3"	30'	30	13.5	3.0
3"	32'	32	14.4	3.2
3"	34'	34	15.3	3.4
3"	36'	36	16.2	3.6
3"	38'	38	17.1	3.8
3"	40'	40	18.0	4.0
3"	42'	42	18.9	4.2
3"	44'	44	19.8	4.4
3"	46'	46	20.7	4.6
3"	48'	48	21.6	4.8
3"	50'	50	22.5	5.0
3"	52'	52	23.4	5.2
3"	54'	54	24.3	5.4
3"	56'	56	25.2	5.6
3"	58'	58	26.1	5.8
3"	60'	60	27.0	6.0

ATTENTION:
 DUCT WEIGHT (LBS) PER FOOT: 1.0
 DUCT WEIGHT (KGS) PER FOOT: 0.45
 DUCT WEIGHT (LBS) PER FOOT: 1.2
 DUCT WEIGHT (KGS) PER FOOT: 0.54
 DUCT WEIGHT (LBS) PER FOOT: 1.4
 DUCT WEIGHT (KGS) PER FOOT: 0.63
 DUCT WEIGHT (LBS) PER FOOT: 1.6
 DUCT WEIGHT (KGS) PER FOOT: 0.72
 DUCT WEIGHT (LBS) PER FOOT: 1.8
 DUCT WEIGHT (KGS) PER FOOT: 0.81
 DUCT WEIGHT (LBS) PER FOOT: 2.0
 DUCT WEIGHT (KGS) PER FOOT: 0.90
 DUCT WEIGHT (LBS) PER FOOT: 2.2
 DUCT WEIGHT (KGS) PER FOOT: 0.99
 DUCT WEIGHT (LBS) PER FOOT: 2.4
 DUCT WEIGHT (KGS) PER FOOT: 1.08
 DUCT WEIGHT (LBS) PER FOOT: 2.6
 DUCT WEIGHT (KGS) PER FOOT: 1.17
 DUCT WEIGHT (LBS) PER FOOT: 2.8
 DUCT WEIGHT (KGS) PER FOOT: 1.26
 DUCT WEIGHT (LBS) PER FOOT: 3.0
 DUCT WEIGHT (KGS) PER FOOT: 1.35
 DUCT WEIGHT (LBS) PER FOOT: 3.2
 DUCT WEIGHT (KGS) PER FOOT: 1.44
 DUCT WEIGHT (LBS) PER FOOT: 3.4
 DUCT WEIGHT (KGS) PER FOOT: 1.53
 DUCT WEIGHT (LBS) PER FOOT: 3.6
 DUCT WEIGHT (KGS) PER FOOT: 1.62
 DUCT WEIGHT (LBS) PER FOOT: 3.8
 DUCT WEIGHT (KGS) PER FOOT: 1.71
 DUCT WEIGHT (LBS) PER FOOT: 4.0
 DUCT WEIGHT (KGS) PER FOOT: 1.80
 DUCT WEIGHT (LBS) PER FOOT: 4.2
 DUCT WEIGHT (KGS) PER FOOT: 1.89
 DUCT WEIGHT (LBS) PER FOOT: 4.4
 DUCT WEIGHT (KGS) PER FOOT: 1.98
 DUCT WEIGHT (LBS) PER FOOT: 4.6
 DUCT WEIGHT (KGS) PER FOOT: 2.07
 DUCT WEIGHT (LBS) PER FOOT: 4.8
 DUCT WEIGHT (KGS) PER FOOT: 2.16
 DUCT WEIGHT (LBS) PER FOOT: 5.0
 DUCT WEIGHT (KGS) PER FOOT: 2.25
 DUCT WEIGHT (LBS) PER FOOT: 5.2
 DUCT WEIGHT (KGS) PER FOOT: 2.34
 DUCT WEIGHT (LBS) PER FOOT: 5.4
 DUCT WEIGHT (KGS) PER FOOT: 2.43
 DUCT WEIGHT (LBS) PER FOOT: 5.6
 DUCT WEIGHT (KGS) PER FOOT: 2.52
 DUCT WEIGHT (LBS) PER FOOT: 5.8
 DUCT WEIGHT (KGS) PER FOOT: 2.61
 DUCT WEIGHT (LBS) PER FOOT: 6.0
 DUCT WEIGHT (KGS) PER FOOT: 2.70

PREWORK NOTES:
 1. Verify ceiling height meets minimum clearance requirements.
 2. Verify duct weight per foot meets ceiling load capacity.
 3. Verify duct length meets installation requirements.
 4. Verify duct diameter meets installation requirements.
 5. Verify duct material meets installation requirements.

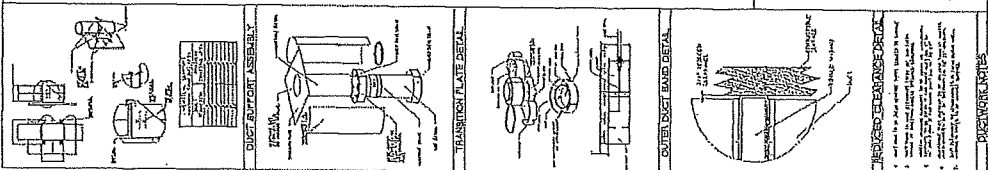

REV	DATE	DESCRIPTION	BY	CHKD
1	01/22/2017	ISSUE FOR PERMITS	JL	
2	01/22/2017	ISSUE FOR PERMITS	JL	
3	01/22/2017	ISSUE FOR PERMITS	JL	
4	01/22/2017	ISSUE FOR PERMITS	JL	
5	01/22/2017	ISSUE FOR PERMITS	JL	
6	01/22/2017	ISSUE FOR PERMITS	JL	
7	01/22/2017	ISSUE FOR PERMITS	JL	
8	01/22/2017	ISSUE FOR PERMITS	JL	
9	01/22/2017	ISSUE FOR PERMITS	JL	
10	01/22/2017	ISSUE FOR PERMITS	JL	
11	01/22/2017	ISSUE FOR PERMITS	JL	
12	01/22/2017	ISSUE FOR PERMITS	JL	
13	01/22/2017	ISSUE FOR PERMITS	JL	
14	01/22/2017	ISSUE FOR PERMITS	JL	
15	01/22/2017	ISSUE FOR PERMITS	JL	
16	01/22/2017	ISSUE FOR PERMITS	JL	
17	01/22/2017	ISSUE FOR PERMITS	JL	
18	01/22/2017	ISSUE FOR PERMITS	JL	
19	01/22/2017	ISSUE FOR PERMITS	JL	
20	01/22/2017	ISSUE FOR PERMITS	JL	
21	01/22/2017	ISSUE FOR PERMITS	JL	
22	01/22/2017	ISSUE FOR PERMITS	JL	
23	01/22/2017	ISSUE FOR PERMITS	JL	
24	01/22/2017	ISSUE FOR PERMITS	JL	
25	01/22/2017	ISSUE FOR PERMITS	JL	
26	01/22/2017	ISSUE FOR PERMITS	JL	
27	01/22/2017	ISSUE FOR PERMITS	JL	
28	01/22/2017	ISSUE FOR PERMITS	JL	
29	01/22/2017	ISSUE FOR PERMITS	JL	
30	01/22/2017	ISSUE FOR PERMITS	JL	
31	01/22/2017	ISSUE FOR PERMITS	JL	
32	01/22/2017	ISSUE FOR PERMITS	JL	
33	01/22/2017	ISSUE FOR PERMITS	JL	
34	01/22/2017	ISSUE FOR PERMITS	JL	
35	01/22/2017	ISSUE FOR PERMITS	JL	
36	01/22/2017	ISSUE FOR PERMITS	JL	
37	01/22/2017	ISSUE FOR PERMITS	JL	
38	01/22/2017	ISSUE FOR PERMITS	JL	
39	01/22/2017	ISSUE FOR PERMITS	JL	
40	01/22/2017	ISSUE FOR PERMITS	JL	
41	01/22/2017	ISSUE FOR PERMITS	JL	
42	01/22/2017	ISSUE FOR PERMITS	JL	
43	01/22/2017	ISSUE FOR PERMITS	JL	
44	01/22/2017	ISSUE FOR PERMITS	JL	
45	01/22/2017	ISSUE FOR PERMITS	JL	
46	01/22/2017	ISSUE FOR PERMITS	JL	
47	01/22/2017	ISSUE FOR PERMITS	JL	
48	01/22/2017	ISSUE FOR PERMITS	JL	
49	01/22/2017	ISSUE FOR PERMITS	JL	
50	01/22/2017	ISSUE FOR PERMITS	JL	
51	01/22/2017	ISSUE FOR PERMITS	JL	
52	01/22/2017	ISSUE FOR PERMITS	JL	
53	01/22/2017	ISSUE FOR PERMITS	JL	
54	01/22/2017	ISSUE FOR PERMITS	JL	
55	01/22/2017	ISSUE FOR PERMITS	JL	
56	01/22/2017	ISSUE FOR PERMITS	JL	
57	01/22/2017	ISSUE FOR PERMITS	JL	
58	01/22/2017	ISSUE FOR PERMITS	JL	
59	01/22/2017	ISSUE FOR PERMITS	JL	
60	01/22/2017	ISSUE FOR PERMITS	JL	
61	01/22/2017	ISSUE FOR PERMITS	JL	
62	01/22/2017	ISSUE FOR PERMITS	JL	
63	01/22/2017	ISSUE FOR PERMITS	JL	
64	01/22/2017	ISSUE FOR PERMITS	JL	
65	01/22/2017	ISSUE FOR PERMITS	JL	
66	01/22/2017	ISSUE FOR PERMITS	JL	
67	01/22/2017	ISSUE FOR PERMITS	JL	
68	01/22/2017	ISSUE FOR PERMITS	JL	
69	01/22/2017	ISSUE FOR PERMITS	JL	
70	01/22/2017	ISSUE FOR PERMITS	JL	
71	01/22/2017	ISSUE FOR PERMITS	JL	
72	01/22/2017	ISSUE FOR PERMITS	JL	
73	01/22/2017	ISSUE FOR PERMITS	JL	
74	01/22/2017	ISSUE FOR PERMITS	JL	
75	01/22/2017	ISSUE FOR PERMITS	JL	
76	01/22/2017	ISSUE FOR PERMITS	JL	
77	01/22/2017	ISSUE FOR PERMITS	JL	
78	01/22/2017	ISSUE FOR PERMITS	JL	
79	01/22/2017	ISSUE FOR PERMITS	JL	
80	01/22/2017	ISSUE FOR PERMITS	JL	
81	01/22/2017	ISSUE FOR PERMITS	JL	
82	01/22/2017	ISSUE FOR PERMITS	JL	
83	01/22/2017	ISSUE FOR PERMITS	JL	
84	01/22/2017	ISSUE FOR PERMITS	JL	
85	01/22/2017	ISSUE FOR PERMITS	JL	
86	01/22/2017	ISSUE FOR PERMITS	JL	
87	01/22/2017	ISSUE FOR PERMITS	JL	
88	01/22/2017	ISSUE FOR PERMITS	JL	
89	01/22/2017	ISSUE FOR PERMITS	JL	
90	01/22/2017	ISSUE FOR PERMITS	JL	
91	01/22/2017	ISSUE FOR PERMITS	JL	
92	01/22/2017	ISSUE FOR PERMITS	JL	
93	01/22/2017	ISSUE FOR PERMITS	JL	
94	01/22/2017	ISSUE FOR PERMITS	JL	
95	01/22/2017	ISSUE FOR PERMITS	JL	
96	01/22/2017	ISSUE FOR PERMITS	JL	
97	01/22/2017	ISSUE FOR PERMITS	JL	
98	01/22/2017	ISSUE FOR PERMITS	JL	
99	01/22/2017	ISSUE FOR PERMITS	JL	
100	01/22/2017	ISSUE FOR PERMITS	JL	

24
 25
 26
 27
 28
 29
 30
 31
 32
 33
 34
 35
 36
 37
 38
 39
 40
 41
 42
 43
 44
 45
 46
 47
 48
 49
 50
 51
 52
 53
 54
 55
 56
 57
 58
 59
 60
 61
 62
 63
 64
 65
 66
 67
 68
 69
 70
 71
 72
 73
 74
 75
 76
 77
 78
 79
 80
 81
 82
 83
 84
 85
 86
 87
 88
 89
 90
 91
 92
 93
 94
 95
 96
 97
 98
 99
 100

LA CUCINA
 101 Hyde St.,
 SAN FRANCISCO, CA. 94102

CAPITVE
 2011-10th Ave, Astoria, OR, 97103-1000 (503) 325-1111
 2011-10th Ave, Astoria, OR, 97103-1000 (503) 325-1111

DATE: 01/22/2017
 DRAWN BY: JL
 CHECKED BY: JL
 SCALE: AS SHOWN
 SHEET NO. 14

5-24-18

FS-6.13

FOODSERVICE EQUIPMENT
 HOOD DRAWING

LA CUCINA
 101 HYDE ST
 SAN FRANCISCO, CA 94102

MFSDB
 MYERS FOODSERVICE
 DESIGN+BUILD

EXHIBIT F

FORM OF PERFORMANCE BOND

PERFORMANCE BOND AND PAYMENT (LABOR & MATERIALS) BOND

WHEREAS, La Cocina, Inc. ("Tenant") and the City and County of San Francisco ("City") are parties to a Lease dated as of _____, 20__ ("Lease") for the property commonly known as 101 Hyde Street, San Francisco, California ("Property"); and

WHEREAS, Tenant is required to make certain Improvements to the Property pursuant to Article 6 of the Lease, and Tenant has entered into a _____ [name of contract] ("Contract") with _____ [name of contractor] ("Principal") dated as of _____, 20__, for the performance of such Improvements, as further described in the Contract ("Work"); and

WHEREAS, The Lease requires that Principal furnish a Bond for the faithful performance of the Contract and to furnish a separate Bond for the payment of any materials, provisions, or other supplies, used in, upon, for or about the performance of the work contracted to be done under the Contract ("Work").

NOW, THEREFORE, we the Principal and

_____ as Surety, are firmly bound unto Tenant and the City in the penal sum of

(PERFORMANCE BOND)

(PAYMENT BOND)

_____ and _____

lawful money of the United States for the payment of which sum well and truly to be made, we bind ourselves, our heirs, executors, administrators, successors and assigns, jointly and severally firmly by these presents for the penal sum for a performance bond and an equal and separate penal sum for a separate payment bond.

(PERFORMANCE BOND)

THE CONDITION OF THIS OBLIGATION IS SUCH, that if the above bounded Principal, its heirs, executors, administrators, successors or assigns, shall in all things stand to and abide by, and well and truly keep and perform the covenants, conditions and agreements in the said Contract, including the provisions for liquidated damages in the said Contract, any changes, additions or alterations thereof made as therein provided, on its part, to be kept and performed at the time and in the manner therein specified, and in all respects according to their true intent and meaning, and shall indemnify and save harmless the City, its officers and agents, as therein stipulated, then this obligation shall become null and void; otherwise it shall be and remain in full force and effect.

(PAYMENT BOND)

THE CONDITION OF THIS OBLIGATION IS SUCH; that if Principal, its heirs, executors, administrators, successors or assigns, or its subcontractors, shall fail to pay (i) any of the persons named in California Civil Code Section 9100 for any materials, provisions, or other supplies used in, upon, for or about the performance of work under the Contract, or for any work or labor performed under the Contract; or (ii) amounts due under the California Unemployment Insurance Code with respect to work or labor performed under the Contract; or (iii) for any amounts required to be deducted, withheld, and paid over to the State of California Employment Development Department from the wages of employees of Principal and subcontractors pursuant to Section 13020 of the California Unemployment Insurance Code with respect to such work or labor, that Surety will pay for the same in an amount not exceeding the sum specified in this Bond. In the event that suit is brought upon this Payment Bond, the parties not prevailing in such suit shall pay reasonable attorney's fees and costs incurred by the prevailing parties in such suit.

This Payment Bond shall inure to the benefit of any of the persons named in California Civil Code Section 9100 as to give a right of action to such persons or their assigns in any suit brought against this Bond.

Should the condition of this Payment Bond be fully performed, then this obligation shall become null and void; otherwise, it shall be and remain in full force and effect.

Surety, for value received, hereby expressly agrees that no change, extension of time, modification, alteration or addition to the undertakings, covenants, terms, conditions and agreements of the Contract; or to the work to be performed thereunder, or to the specifications accompanying the same, and no inadvertent overpayment of progress payments, shall in any way affect its obligations on these Bonds; and it does hereby waive notice of any such change, extension of time, modification, alteration or addition to the undertakings, covenants, terms, conditions and agreements of the Contract, or to the Work to be performed thereunder, or to the specifications, or of any inadvertent overpayment of progress payments.

IN WITNESS WHEREOF, the above-bounden parties have executed this instrument under their seal this _____ day of _____, 20____, the name and corporate seal of each corporate party being hereto affixed and these presents duly signed by its undersigned representative, pursuant to authority of its governing body.

Approved as to form:
Dennis J. Herrera
City Attorney

By: _____
Deputy City Attorney

Principal

By: _____

Surety

By: _____

A notary public or other officer completing this certificate verifies only the identity of the individual who signed the document to which this certificate is attached, and not the truthfulness, accuracy, or validity of that document.

State of California)
County of San Francisco) ss.

On _____, before me, _____, a notary public in and for said State, personally appeared _____, who proved to me on the basis of satisfactory evidence to be the person(s) whose name(s) is/are subscribed to the within instrument and acknowledged to me that he/she/they executed the same in his/her/their authorized capacity(ies), and that by his/her/their signature(s) on the instrument the person(s), or the entity upon behalf of which the person(s) acted, executed the instrument.

I certify under PENALTY OF PERJURY under the laws of the State of California that the foregoing paragraph is true and correct.

WITNESS my hand and official seal.

Signature _____ (Seal)

EXHIBIT G

STANDARD UTILITIES

The standards set forth below describe the basic utilities and services that will be in effect for the Building. City reserves the right to adopt any nondiscriminatory modifications and additions to such standards which do not materially impair Tenant's rights under this Lease or Tenant's use of the Premises. City shall give Tenant reasonable advance notice, in accordance with the provisions of this Lease, of any material modifications and additions, which shall be subject to the reasonable approval of Tenant.

Subject to the terms and conditions of this Lease, City shall provide the following basic utilities and services:

A. Ventilation; Heating and Air-Conditioning. Ventilation to the Building, and air-conditioning and heating to the Building in season and at such temperatures and in such amounts as Tenant and City collectively deem reasonably necessary for the comfortable occupancy of the Building, subject to applicable governmental laws, ordinances, rules and regulations. Tenant shall not alter, adjust, tamper with or in any manner affect the installations or facilities supplying climate control to the Building, except to the extent included in Exhibit E.

B. Electricity. Electric current to the Building on a 24-hours a day, 7-days a week basis, in such quantity as is reasonably determined by City to service standard commercial restaurant lighting and normal fractional horsepower kitchen equipment. Tenant shall not connect any apparatus or device with wires, conduits or pipes, or other means by which the services are supplied, for the purpose of using additional or extraordinary amounts of the services without the prior written consent of City. At all times, Tenant's use of electric current shall not exceed the capacity of feeders to the Building or the risers or wiring installation, except as provided in working drawings to City.

C. Water. Water available at current points of supply in public areas for drinking and lavatory purposes only, and hot and cold water in the Building for drinking and kitchen purposes, on a 24-hours a day, 7-days a week basis.

EXHIBIT H

RULES AND REGULATIONS

1. The sidewalks, halls, passages, exits, entrances, and vertical transportation of the Building shall not be obstructed by Tenant or used by it for any purpose other than for ingress to and egress from the Premises. City shall in all cases retain the right to control and prevent access thereto of all persons whose presence in the judgment of City would be prejudicial to the safety, character, reputation and interests of the Building, provided that nothing herein contained shall be construed to prevent such access to persons with whom Tenant normally deals in the ordinary course of its business, unless such persons are engaged in illegal activities. Tenant shall not go upon the roof of the Building without the written consent of City or, except in areas that City may designate as "Common Areas" from time to time.
2. No sign, placard, picture, name, advertisement or notice visible from the exterior of the Premises shall be installed or displayed by Tenant on any part of the outside or inside of the Building without the prior written consent of City. City shall have the right to remove, at Tenant's expense and without notice, any sign installed or displayed in violation of this rule. All approved signs or lettering on doors shall be printed, painted, affixed or inscribed at the expense of Tenant by a person approved by City, which approval will not be unreasonably withheld. City's approval as Landlord does not imply any necessary regulatory approvals that Tenant may be required to obtain.
3. Any cooking done by Tenant on the Premises shall be in accordance with all applicable federal, state and local laws, codes, ordinances, rules and regulations.
4. No person or persons other than those approved by City shall be permitted to enter the Building for the purpose of cleaning same.
5. City will furnish Tenant with one (1) key to the Premises, free of charge. City may make a reasonable charge for such additional keys and for having locks changed. Tenant shall not make or have made additional keys without City's prior written consent, which consent shall not be unreasonably withheld or delayed. Tenant shall not alter any lock or install any new or additional locking devices without the prior written consent of City. All locks installed in the Premises, excluding Tenant's vaults and safes, or special security areas (which shall be designated by Tenant in a written notice to City), shall be keyed to the Building master key system. City may make reasonable charge for any additional lock or any bolt (including labor) installed on any door of the Premises. Tenant, upon the termination of its tenancy, shall deliver to City all keys to doors in the Premises. If Tenant loses any keys, Tenant shall pay City for the cost of re-keying the Premises.
6. Tenant shall schedule with City, by written notice given no less than forty-eight (48) hours in advance, its move into or out of the Building, which moving shall occur only on weekend days if required by City; and Tenant shall reimburse City upon demand for any additional security or other charges incurred by City as a consequence of such moving. The persons employed by Tenant to move equipment or other items in or out of the Building must be acceptable to City. City shall have the right to prescribe the weight, size and position of all equipment, materials, supplies, furniture or other property brought into the Building. Heavy objects shall, if considered necessary by City, stand on wood strips of such thickness as is necessary to properly distribute the weight of such objects. City will not be responsible for loss of or damage to any such property from any cause, and all damage done to the Building by moving or maintaining Tenant's property shall be repaired at the expense of Tenant.

7. Tenant shall not use or keep in the Premises or the Building any kerosene, gasoline or flammable, combustible or noxious fluid or materials or use any method of heating or air conditioning other than those limited quantities necessary for the operation and maintenance of Tenant's business. Tenant shall not use, keep or permit or suffer the Premises to be occupied or used in a manner offensive or objectionable to City by reason of noise, odors, and/or vibrations.
8. No curtains, draperies, blinds, shutters, shades, screens or other coverings, hangings or decorations shall be attached to, hung or placed in, or used in connection with any window of the Building without City's prior written consent.
9. Tenant shall see that the doors of the Premises are closed and locked and that all water faucets, water apparatus and utilities are shut off before Tenant or Tenant's employees leave the Premises, so as to prevent waste or damage, and for any default or carelessness in this regard Tenant shall make good all injuries sustained by other tenants or occupants of the Building or City. Tenant shall at all times comply with any rules or orders of the fire department with respect to ingress and egress.
10. The toilet rooms, toilets, urinals, wash bowls and other apparatus shall not be used for any purpose other than that for which they were constructed, no foreign substance of any kind whatsoever shall be deposited therein. The expense of any breakage, stoppage or damage resulting in any violation of this rule shall be borne by Tenant.
11. Except with City's prior consent or as otherwise permitted in the Lease, Tenant shall not sell, or permit the sale from the Premises of, or use or permit the use of any sidewalk or mall area adjacent to the Premises for the sale of, newspapers, magazines, periodicals, theater tickets or any other goods, merchandise or service, nor shall Tenant carry on, or permit or allow any employee or other person to carry on, business in or from the Premises for the service or accommodation of occupants or any other portion of the Building, nor shall the Premises be used for manufacturing of any kind, or for any business or activity other than that specifically provided for in Tenant's lease or as otherwise consented to by City in writing.
12. Tenant shall not install any radio or television antenna, loudspeaker, or other device on or about the roof area or exterior walls of the Building. Tenant shall not interfere with radio or television broadcasting or reception from or in the Building or elsewhere.
13. Tenant shall not use in any space, or in the common areas of the Building, any hand-trucks except those equipped with rubber tires and side guards or such other material-handling equipment as City may approve. No other vehicles of any kind shall be brought by Tenant into the Building or kept in or about the Premises without prior written consent of City.
14. Tenant shall store all its trash and garbage within the Premises until removal of the same to such location in the Building as may be designated from time to time by City. No material shall be placed in the Building trash boxes or receptacles if such material is of such nature that it may not be disposed of in the ordinary and customary manner of removing and disposing of trash and garbage in the City of San Francisco without being in violation of any law or ordinance governing such disposal.
15. All loading and unloading of merchandise, supplies, materials, garbage and refuse shall be made only through such entryways and freight elevators and at such times as City shall designate. In its use of the loading areas of the Building, Tenant shall not obstruct or permit the obstruction of said loading areas, and at no time shall Tenant park vehicles therein except for immediate loading and unloading purposes.

16. Canvassing, soliciting, peddling or distribution of handbills or any other written material in the Building is prohibited and Tenant shall cooperate to prevent the same.
17. Tenant shall immediately, upon request from City (which request need not be in writing), reduce its lighting in the Premises for temporary periods designated by City, when required in City's judgment to prevent overloads of the mechanical or electrical systems of the Building.
18. City reserves the right to select the name of the Building and to make such change or changes of name as it may deem appropriate from time to time, and Tenant shall not refer to the Building by any name other than: (i) the name as selected by City (as the same may be changed from time to time), or (ii) the postal address approved by the United States Post Office. Tenant shall not use the name of the Building in any respect other than as an address of its operation in the Building without the prior written consent of the City.
19. Tenant assumes all responsibility for protecting its Premises from theft, robbery and pilferage, which includes keeping doors locked and other means of entry closed.
20. No vending machine shall be maintained or operated within the Premises or the Building without City's prior written consent.
21. City reserves the right to exclude or expel from the Building any person who is, in the judgment of City, intoxicated or under the influence of drugs or who is in violation of any of the Rules or Regulations of the Building.
22. No animal or bird shall be permitted in the Premises or the Building, except for seeing eye dogs or other licensed service animals when in the company of their masters.
23. The requirements of Tenant will be attended to only upon application by telephone or writing or in person at the management office of the Building. Employee of City shall not perform any work or do anything outside of their regular duties unless under special instructions from City.
24. City may waive any one or more of these Rules and Regulations for the benefit of any particular tenant or tenants, but no such waiver by City shall be construed as a waiver of these Rules and Regulations in favor of any other tenant or tenants, nor prevent City from thereafter enforcing any such Rules and Regulations against any or all of the tenants of the Building.
25. Wherever the word "Tenant" occurs in these Rules and Regulations, it is understood and agreed that it shall mean Tenant's associates, agents, clerks, employees and visitors. Wherever the word "City" occurs in these Rules and Regulations, it is understood and agreed that it shall mean City's assigns, agents, officers, employees and visitors.
26. These Rules and Regulations are in addition to, and shall not be construed in any way to modify, alter or amend, in whole or part, the terms, covenants, agreements and conditions of any lease of premises in the Building.
27. City reserves the right to make such other and reasonable rules and regulations as in its judgment may from time to time be needed for the safety, care and cleanliness of the Building, and for the preservation of good order therein.
28. Tenant shall be responsible for the observance of all the foregoing Rules and Regulations by Tenant's employees, agents, clients, customers, invitees and guests.

EXHIBIT I

FIRST SOURCE HIRING AGREEMENT

[SEE ATTACHED]



Edwin M. Lee, Mayor

**Form B: First Source Hiring Agreement
For Tenant/Concessionaire/Franchisee/Easement Holder of City Property**

This First Source Hiring Agreement (this "Agreement"), is made as of 06/06/18, by and between La Cocina (the "Lessee"), and the First Source Hiring Administration, (the "FSHA"), collectively the "Parties":

RECITALS

WHEREAS, Lessee plans to occupy the property owned or controlled by the City and County of San Francisco ("City") at 101 Hyde Street ("Premises") pursuant to a lease between Lessee and City dated June 1, 2018 ("Lease") which requires a First Source Hiring Agreement between Lessee and FSHA; and,

WHEREAS, as a material part of the consideration given by Lessee under the Lease, Lessee has agreed to execute this Agreement and the First Source Employer's Projection of Entry-Level Positions form attached to this Agreement as *Exhibit A* (the "Projection Form") and participate in the Workforce System managed by the Office of Economic and Workforce Development ("OEWD") as established by the City and County of San Francisco pursuant to Chapter 83 of the San Francisco Administrative Code ("Chapter 83"); and

WHEREAS, Lessee is required to provide notice of the requirements of Chapter 83 in leases, subleases and other occupancy contracts for use of the Premises;

NOW, THEREFORE, in consideration of the mutual covenants set forth herein and other good and valuable consideration, the receipt and sufficiency of which is hereby acknowledged, Parties covenant and agree as follows:

1. DEFINITIONS

For purposes of this Agreement, initially capitalized terms shall be defined as follows:

- a. **Entry Level Position:** Any non-managerial position that requires no education above a high school diploma or certified equivalency, and less than two (2) years training or specific preparation, and shall include temporary, permanent, trainee and intern positions.
- b. **Workforce System:** The First Source Hiring Administrator established by the City and managed by OEWD.
- c. **Referral:** A member of the Workforce System who has been identified by OEWD as having the appropriate training, background and skill sets for a Lessee specified Entry Level Position.

2. OEWD WORKFORCE SYSTEM PARTICIPATION

- a. Lessee shall notify OEWD's Business Team of every available Entry Level Position and provide OEWD 10 business days to recruit and refer qualified candidates prior to advertising such position to the general public. Lessee shall provide feedback including but not limited to job seekers interviewed, including name, position title, starting salary and employment start date of those individuals hired by the Lessee no later than 10 business days after date of interview or hire. Lessee will also provide feedback on reasons as to why referrals were not hired. Lessee shall have the sole discretion to interview any Referral by OEWD and will inform OEWD's Business Team why specific persons referred were not interviewed. Hiring decisions shall be entirely at the discretion of Lessee.
- b. This Agreement shall be in full force and effect throughout the term of the Lease.

3. GOOD FAITH EFFORT TO COMPLY WITH ITS OBLIGATIONS HEREUNDER

Lessee will make good faith efforts to comply with its obligations under this Agreement. Determination of good faith efforts shall be based on all of the following:

- a. Lessee will execute and deliver this Agreement and the Projection Form to OEWD upon entering into the Lease. Lessee will also accurately complete and submit the Projection Form annually to reflect employment conditions.
- b. Lessee agrees to register with OEWD's Referral Tracking System, upon execution of this Agreement.
- c. Lessee shall notify OEWD's Business Services Team of all available Entry Level Positions 10 business days prior to posting with the general public. The Lessee must identify a single point of contact responsible for communicating Entry-Level Positions and take active steps to ensure continuous communication with OEWD's Business Services Team
- d. If Lessee's operations create Entry Level Positions, Lessee will use good faith efforts to meet the hiring goals established by the FSHA for filling open Entry Level Positions with First Source referrals. Specific hiring decisions shall be the sole discretion of the Lessee.
- e. Nothing in this Agreement shall be interpreted to prohibit the continuation of existing workforce training agreements or to interfere with consent decrees, collective bargaining agreements, or existing employment contracts. In the event of a conflict between this Agreement and an existing agreement, the terms of the existing agreement shall supersede this Agreement.

Lessee's failure to meet the criteria set forth in this Section 3 does not impute "bad faith" and shall trigger a review of the referral process and compliance with this Agreement. Failure and noncompliance with this Agreement will result in penalties as defined in Chapter 83, Lessee agrees to review Chapter 83, and execution of this Agreement denotes that Lessee agrees to its terms and conditions.

4. NOTICE

All notices to be given under this Agreement shall be in writing and sent via mail or email as follows:

ATTN: Business Services, Office of Economic and Workforce Development
1 South Van Ness Avenue, 5th Floor, San Francisco, CA 94103
Email: Business.Services@sfgov.org

5. MISCELLANEOUS

This Agreement contains the entire agreement between the parties as to the subject matter hereof and shall not be modified in any manner except by an instrument in writing executed by the parties or their respective successors. If any term or provision of this Agreement shall be held invalid or unenforceable, the remainder of this Agreement shall not be affected. If this Agreement is executed in one or more counterparts, each shall be deemed an original and all, taken together, shall constitute one and the same instrument. This Agreement shall inure to the benefit of and shall be binding upon the parties to this Agreement and their respective heirs, successors and assigns. If there is more than one person comprising Lessee, their obligations shall be joint and several. Section titles and captions contained in this Agreement are inserted as a matter of convenience and for reference and in no way define, limit, extend or describe the scope of this Agreement or the intent of any of its provisions. This Agreement shall be governed and construed by laws of the State of California.

IN WITNESS WHEREOF, the following have executed this Agreement as of the date set forth above.

Date: 06/08/18

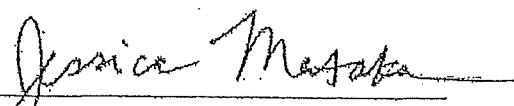
Signature: 

Name of Authorized Signer: Jessica Mataka

Company: La Cocina

Address: 2948 Folsom Street

Phone: (415)824-2729 x 307

Email: jessica@lacocinasf.org



CITY AND COUNTY OF SAN FRANCISCO
OFFICE OF ECONOMIC AND WORKFORCE DEVELOPMENT



FIRST SOURCE HIRING PROGRAM

WORKFORCE PROJECTIONS FORM

**EXHIBIT A WORKFORCE PROJECTIONS
FOR BUSINESS, COMMERCIAL, OPERATION AND LEASE OCCUPANCY**

Business Name: La Cocina Phone: (415)824-2729
Main Contact: Jessica Mataka, Development Manager Email: jessica@lacocinasf.org

Jessica Mataka _____ 06/08/18
Signature of authorized representative* Date

By signing this form, the lessee agrees to participate in the Workforce System managed by the Office of Economic and Workforce Development (OEWD) and comply with the provisions of its First Source Hiring Agreement pursuant to San Francisco Administrative Code Chapter 83.

Instructions:

- Upon entering into leases for the commercial space of the building, the Lessee must submit to OEWD, a signed First Source Agreement, including its signature to Exhibit A thereto. Lessee will also complete and submit Exhibit A annually to reflect employment conditions.
- The employer must notify the First Source Hiring Program (Contact info below) if an Entry Level Position becomes available.

Section 1: Select your Industry

- | | | |
|--|--|--|
| <input type="checkbox"/> Auto Repair | <input type="checkbox"/> Entertainment | <input type="checkbox"/> Personal Services |
| <input type="checkbox"/> Business Services | <input type="checkbox"/> Elder Care | <input type="checkbox"/> Professionals |
| <input type="checkbox"/> Consulting | <input type="checkbox"/> Financial Services | <input type="checkbox"/> Real Estate |
| <input type="checkbox"/> Construction | <input type="checkbox"/> Healthcare | <input type="checkbox"/> Retail |
| <input type="checkbox"/> Government Contract | <input type="checkbox"/> Insurance | <input type="checkbox"/> Security |
| <input type="checkbox"/> Education | <input type="checkbox"/> Manufacturing | <input type="checkbox"/> Wholesale |
| <input checked="" type="checkbox"/> Food and Drink | <input type="checkbox"/> I don't see my industry (Please Describe) _____ | |

Section 2: Describe Primary Business Activity

Non-profit business incubator operating a food hall to provide business expansion opportunities to low-income women, immigrant and POC food entrepreneurs.

Section 3: Provide information on all Entry Level Positions

Entry-Level Position Title	Job Description	Number of New Hires	Projected Hiring Date
Lead Cook	The Lead Cook oversees the operations of the kitchen which include supervising the kitchen staff to make sure duties are performed appropriately and making sure the kitchen areas meet health and safety requirements as mandated by law.	7	01/15/18
Prep Cook	Line and prep cooks provide support to the Chef/owner and lead cook to execute on all orders and serve food for customers.	7	01/15/18
Cashier	Cashiers are responsible for all transactions between the business and guests.	7	01/15/18
Floor Captains	Floor captains are responsible for maintaining the	2	01/15/18

IF(6/18/2018)



CITY AND COUNTY OF SAN FRANCISCO
OFFICE OF ECONOMIC AND WORKFORCE DEVELOPMENT



FIRST SOURCE HIRING PROGRAM

WORKFORCE PROJECTIONS FORM

**EXHIBIT A WORKFORCE PROJECTIONS
FOR BUSINESS, COMMERCIAL, OPERATION AND LEASE OCCUPANCY**

	cleanliness and appearance of the marketplace during the day and welcoming guests on behalf of La Cocina.		
Bartender	Bartenders manage all beverage service, filling orders from lessee POS during the day and operating their own bar in the afternoons and evenings.	1	01/15/18
Barback	Barbacks provide support to bartenders during the busiest hours of service.	1	01/15/18
Safety Captains	Community Safety Captains welcome guests at all entrances to the Municipal Marketplace and Law Library. Captains ensure that guests are respectful to each other, adhere to the rules of the space and have access to all services that they may need.	2	01/15/18

Please email, fax, or mail this form SIGNED to:

ATTN: Business Services
Office of Economic and Workforce Development
1 South Van Ness Avenue, 5th Floor, San Francisco, CA 94103
Tel: 415-701-4848
Fax: 415-701-4897
mailto:Business.Services@sfgov.org
Website: www.workforcedevelopmentsf.org



SAN FRANCISCO PLANNING DEPARTMENT

General Plan Referral

1650 Mission St.
Suite 400
San Francisco,
CA 94103-2479

Date: August 30, 2017
Case No. Case No. 2017-010661GPR
101 Hyde Street – General Plan Referral (Interim Lease
Activation)

Reception:
415.558.6378

Fax:
415.558.6409

Block/Lot No.: 0346/003A
Project Sponsor: Joshua Keene
San Francisco Real Estate Department
25 Van Ness Ave. Suite 400
San Francisco, CA 94102

*Planning
Information:*
415.558.6377

Applicant: Same as Above

Staff Contact: Rachael Tanner – (415) 575-8730
Rachael.Tanner@sfgov.org

Recommendation: Finding the project, on balance, is in conformity with
the General Plan

Recommended

By:

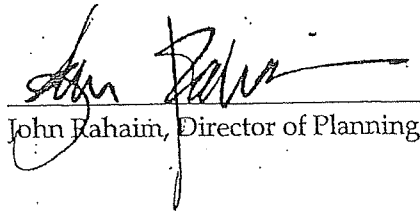
John Rahaim, Director of Planning

PROJECT DESCRIPTION

The Project is the City's proposed interim lease of approximately 7,500 gross square feet of 101 Hyde Street; the use will be for operation of a commercial use, including food services, retail, restaurant, and/or bar. The property, 101 Hyde Street, is currently owned by the City and County of San Francisco; specifically the Mayor's Office of Housing and Community Development (MOHCD). In the long-term, MOHCD will develop the site into affordable housing that will serve the residents of San Francisco. In the intervening time, this interim lease will allow for activation and use of the site. The submittal is for a General Plan Referral to recommend whether the Project is in conformity with the General Plan, pursuant to Section 4.105 of the Charter; and Section 2A.52 and 2A.53 of the Administrative Code.

ENVIRONMENTAL REVIEW

On August 30, 2017 the Environmental Planning Division of the Department determined that the Project (lease of 7,500-square feet of 101 Hyde Street) is categorically exempt under CEQA Guidelines Section 15303 on 8/30/2017.

GENERAL PLAN COMPLIANCE AND BASIS FOR RECOMMENDATION

The Project is the City's proposed interim lease activation of approximately 7,500 gross square feet of 101 Hyde Street; the use will be for operation of a commercial use, including food services, retail, restaurant, and/or bar. The Project is consistent with the Eight Priority Policies of Planning Code Section 101.1 as described in the body of this letter and is, on balance, in conformity with the following Objectives and Policies of the General Plan:

DOWNTOWN PLAN

OBJECTIVE 1: Manage economic growth and change to ensure enhancement of the total city living and working environment.

POLICY 1.1

Encourage development which produces substantial net benefits and minimizes undesirable consequences. Discourage development which has substantial undesirable consequences which cannot be mitigated.

In the long-run, this site will provide affordable housing for San Franciscans. The development of housing will enhance the living and work environment in the downtown C-3-G area. In contrast, a vacancy at this site between the present time and project completion would detract from the total city living environment. Specifically, such a vacancy would have substantial and undesirable consequences. Activation of the site through an interim lease would allow the City and County to maximize the benefits of the site and minimize the undesirable consequences.

OBJECTIVE 16: Create and maintain attractive, interesting urban streetscapes.

POLICY 16.4: Use designs and materials and include activities at the ground floor to create pedestrian interest.

Retail Uses

Shops and restaurants contribute liveliness and visual interest to street frontages, lobbies and plazas of office buildings. Group floor space fronting on streets, pedestrian ways, plazas, and courtyards outside the retail district should be devoted primarily to retail and service uses that are of interest to pedestrians and that meet the needs of workers and visitors to nearby buildings.

Leasing 101 Hyde Street for interim commercial uses is consistent with the above policy and objective found in the Downtown Plan. The lease will ensure this one story corner building, which fronts two streets, has a use that meets the interests of pedestrians, visitors, and nearby workers and residents.

HOUSING ELEMENT

OBJECTIVE 1: Identify and make available for development adequate sites to meet the City's housing needs, especially permanently affordable housing.

In accordance with Objective 1 of the Housing Element, the Mayor's Office of Housing and Community Development acquired the site in order to build permanently affordable housing. This interim lease allows MOHCD to hold the land in productive use while waiting for the available funds to build housing.

PROPOSITION M FINDINGS – PLANNING CODE SECTION 101.1

Planning Code Section 101.1 establishes Eight Priority Policies and requires review of discretionary approvals and permits for consistency with said policies. The Project is found to be consistent with the Eight Priority Policies as set forth in Planning Code Section 101.1 for the following reasons:

Eight Priority Policies Findings

The subject project is found to be consistent with the Eight Priority Policies of Planning Code Section 101.1 in that:

The proposed project is found to be consistent with the eight priority policies of Planning Code Section 101.1 in that:

1. That existing neighborhood-serving retail uses be preserved and enhanced and future opportunities for resident employment in and ownership of such businesses enhanced.

The Project would have no adverse effect on neighborhood serving retail uses or opportunities for employment in or ownership of such businesses. The Project will have a positive effect on nearby retail and employment, contributing to a continuous retail experience on the street and providing employment at the site.

2. That existing housing and neighborhood character be conserved and protected in order to preserve the cultural and economic diversity of our neighborhood.

The Project would have no adverse effect on the City's housing stock or on neighborhood character. The existing housing and neighborhood character will be not be negatively affected.

3. That the City's supply of affordable housing be preserved and enhanced.

The Project would have no adverse effect on the City's supply of affordable housing.

4. That commuter traffic not impede MUNI transit service or overburden our streets or neighborhood parking.

The Project would not result in commuter traffic impeding MUNI's transit service, overburdening the streets or altering current neighborhood parking.

5. That a diverse economic base be maintained by protecting our industrial and service sectors from displacement due to commercial office development, and that future opportunities for residential employment and ownership in these sectors be enhanced.

The Project would not adversely affect the existing economic base in this area. This will enhance opportunities for employment in the area.

6. That the City achieve the greatest possible preparedness to protect against injury and loss of life in an earthquake.

The Project would not adversely affect achieving the greatest possible preparedness against injury and loss of life in an earthquake.

7. That landmarks and historic buildings be preserved.

This site and building are not landmarks or of historic significance.

8. That our parks and open space and their access to sunlight and vistas be protected from development.

The Project would have no adverse effect on parks and open space or their access to sunlight and vista.

RECOMMENDATION: Finding the Project, on balance, in-conformity with the General Plan

"E:\Citywide\General Plan\General Plan Referrals\2017\2017-010661GPR - 101 Hyde Street - Interim Lease Activation\GPR_101 Hyde Street.docx"



City and County of San Francisco: Office of Mayor London N. Breed
Economic and Workforce Development: Joaquín Torres, Director

February 12, 2019

Honorable Board of Supervisors
City and County of San Francisco
Room 244, City Hall
1 Dr. Carlton B. Goodlett Place
San Francisco, CA 94102

RE: 101 Hyde Street – Multi-Year Commercial Lease – La Cocina, Inc.

Dear Board members:

Attached for your consideration is a resolution authorizing the execution of a lease of City-owned property located at 101 Hyde Street (the "Property") to La Cocina, Inc. ("La Cocina" or tenant). If approved, the lease would begin upon approval by the Board of Supervisors and Mayor and will last until it expires on December 31, 2025. La Cocina currently controls the property under a year-to-year lease and this proposed agreement would replace that.

The City, through its Mayor's Office of Housing and Community Development ("MOHCD"), acquired the Property in August of 2016 for the purpose of future development into 100% affordable housing. As development of the Property is not expected for several years, this lease serves to provide community serving, interim activation during this pre-development period. Interim activation was always contemplated as part of the City's acquisition.

In the fall of 2016, La Cocina was selected through a formal request for proposal process, which was led by the City's Office of Economic and Workforce Development and supported by the Real Estate Division and the MOHCD. Upon awarding La Cocina the right to negotiate with the City, the Real Estate Division negotiated the proposed lease that is subject to this resolution.

Under the proposed lease La Cocina will build, manage, and operate the "Municipal Marketplace", a 7,500 square foot food hall and business incubator space for low-income, local food-service entrepreneurs. The Municipal Marketplace will include a shared, up-to-date commercial kitchen and indoor community space. The space will include below market rate kiosks for seven (7) full-time vendors and one (1) for rotating pop-ups, a full service bar which will be separate from the main space, and a large central area for seating and for community gatherings.

The goals of the proposed Municipal Marketplace are; 1) To address the lack of equitable access to brick and mortar business ownership for low-income entrepreneurs in the Bay Area, 2) To increase the number of safe, healthy and affordable eating options for Tenderloin residents and workers and a vibrant and welcoming community gathering space, and 3) To create and refine a successful economic model for business incubator space that can be replicated in ground floor retail space in future affordable housing developments.

As part of this lease, the City is contributing \$525,000 plus an additional \$940,000 of funding from a gift to be received from the San Francisco Foundation. This \$1.465 million contribution will be used to offset a portion of the costs needed to improve the Property for La Cocina's use. The City will collect \$1,000 a month in rent once



the Property is operational and the City will be reimbursed for any expenses it incurs such that the lease will be at no additional cost to the City beyond the above stated contribution.

If you have any programmatic questions, please contact Jorge Rivas at 415-554-7613.

Sincerely,

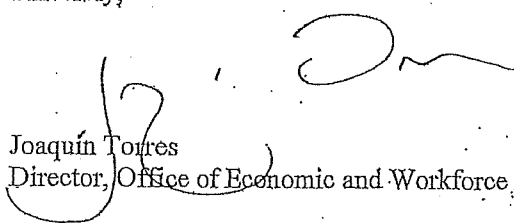
Joaquín Torres
Director, Office of Economic and Workforce Development



OFFICE OF THE MAYOR
SAN FRANCISCO



LONDON N. BREED
MAYOR

2019 FEB 12 PM 4:33
dr

TO: Angela Calvillo, Clerk of the Board of Supervisors
FROM: Kanishka Karunaratne Cheng *KKC*
RE: Lease of City Property – La Cocina, Inc. – 101 Hyde Street - \$12,000 per
year Base Rent
DATE: February 12, 2019

Resolution authorizing the Director of Property to execute a commercial lease between City and La Cocina, Inc., for the lease of City-owned property located at 101 Hyde Street for \$12,000 per year plus percentage rent and a \$1,465,000 allowance for tenant improvements; finding the proposed transaction is in conformance with the City's General Plan, and the eight priority policies of Planning Code, Section 101.1; and adopting CEQA findings.

Please note that Supervisor Haney is a co-sponsor of this legislation.

Should you have any questions, please contact Kanishka Karunaratne Cheng at 415-554-6696.

File # 190166 & 190161
Received in Committee
2/27/19

101 Hyde Interim Use

Budget & Finance Committee
February 27, 2019



Mayor's Office of Housing and Community Development – Amy Chan
Real Estate Department - Josh Keene
Office of Economic and Workforce Development – Lisa Pagan

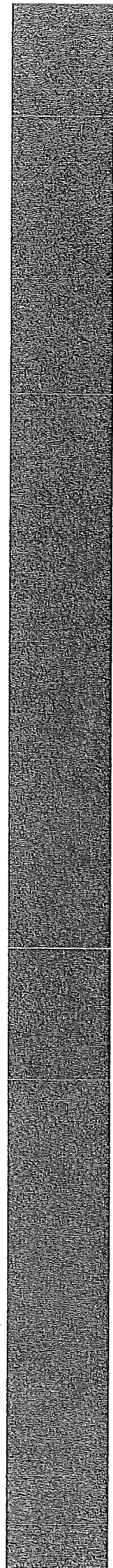

2016-2018

- Land dedication from 1066 Market project for affordable housing development
- \$6MM gift held by San Francisco Foundation:
 - \$1MM for interim activation
 - \$5MM for affordable housing development
- City issued RFP for community-serving interim use and selected La Cocina, Inc.
- City and La Cocina negotiated lease and secured additional public funding for project buildout

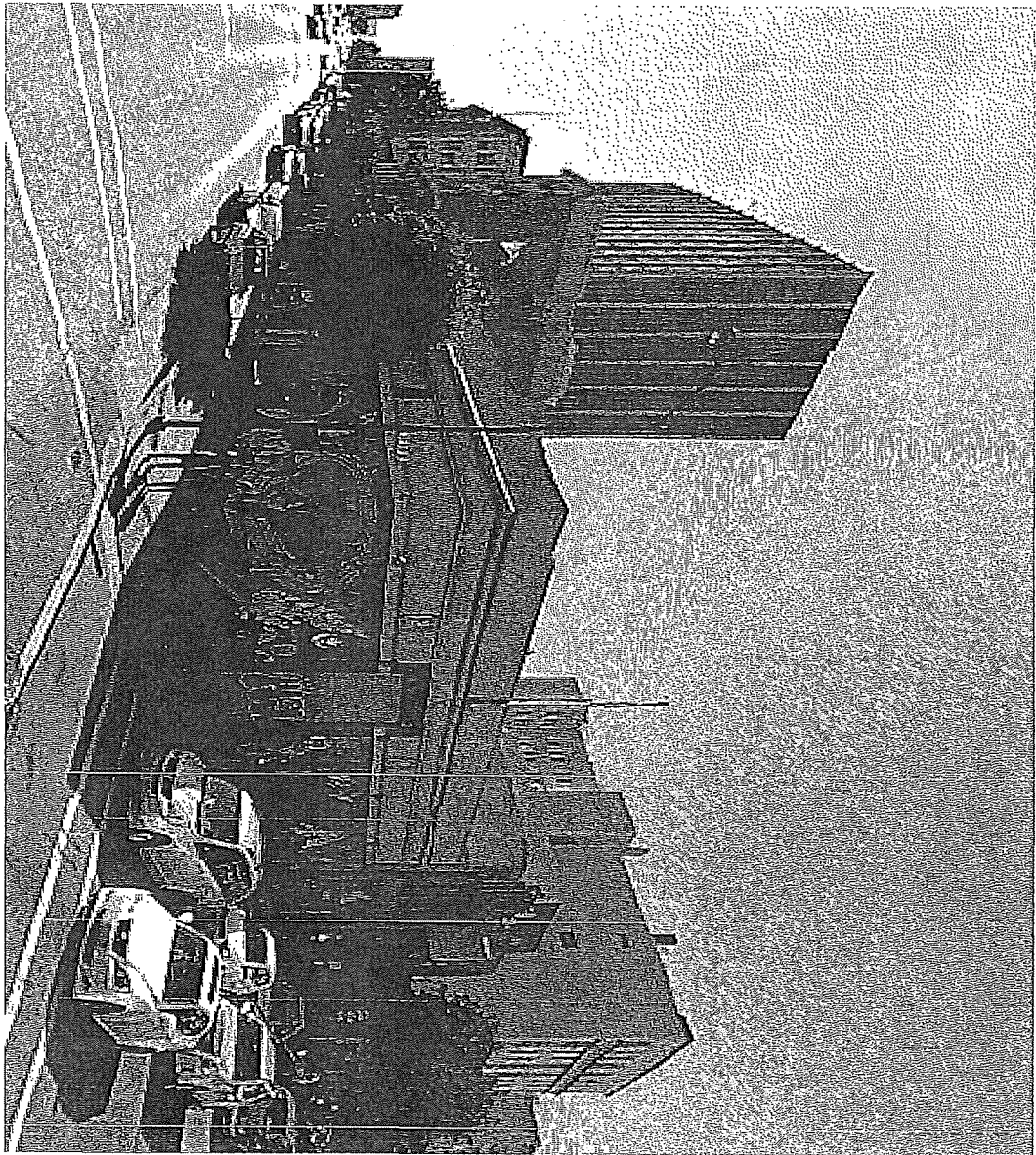
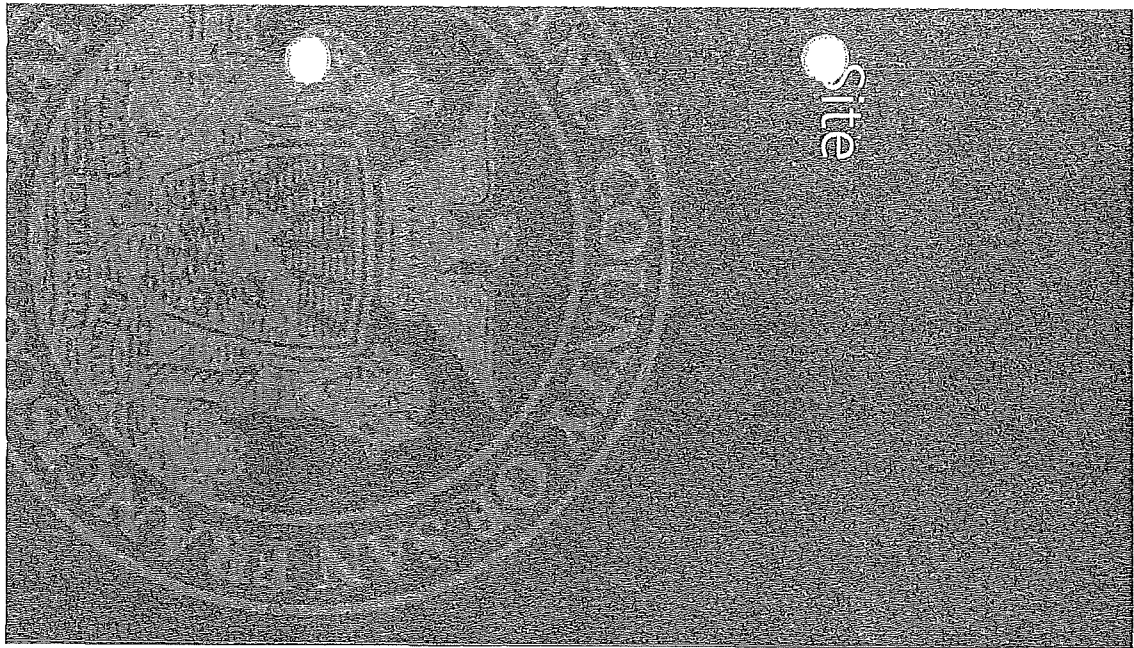

La Cocina Proposal:

- 7,500 SF Food hall and business incubator with commercial kitchen
- 7 Full-time and 1 rotating pop-up vendors that are low-income entrepreneurs who worked with La Cocina to launch micro-businesses
- Vibrant, welcoming community gathering space/seating
- New affordable healthful eating options in the TL
- Partnership with Tenderloin Housing Clinic (THC) who will provide technical assistance on construction management and contract compliance
- THC will also lead neighborhood outreach and serve as the overall liaison with the Tenderloin neighborhood

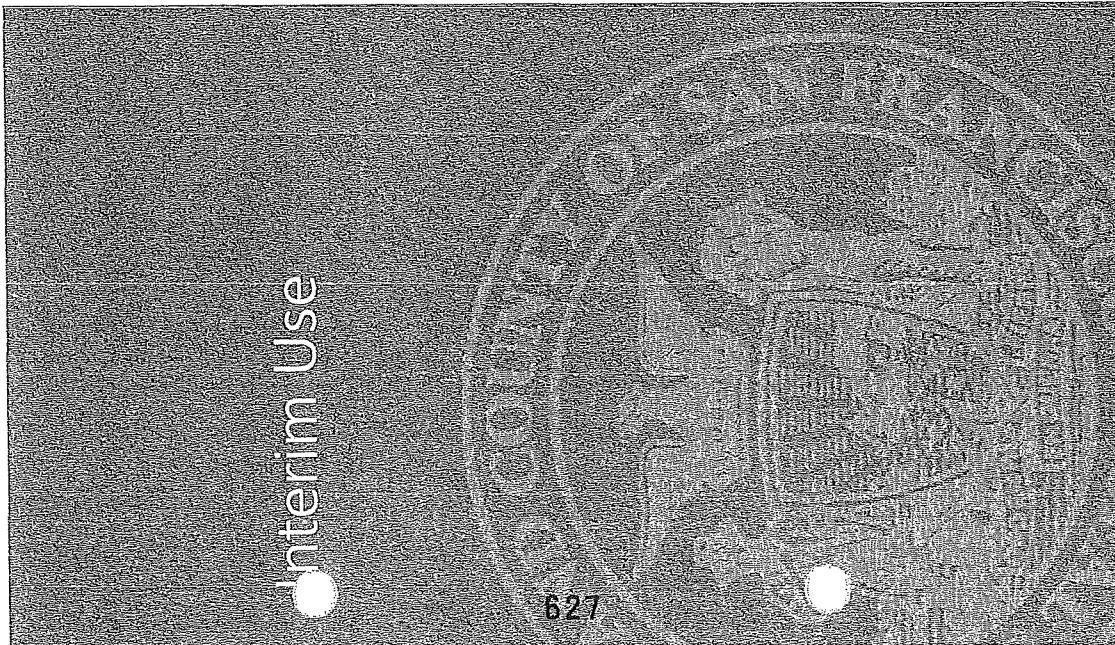

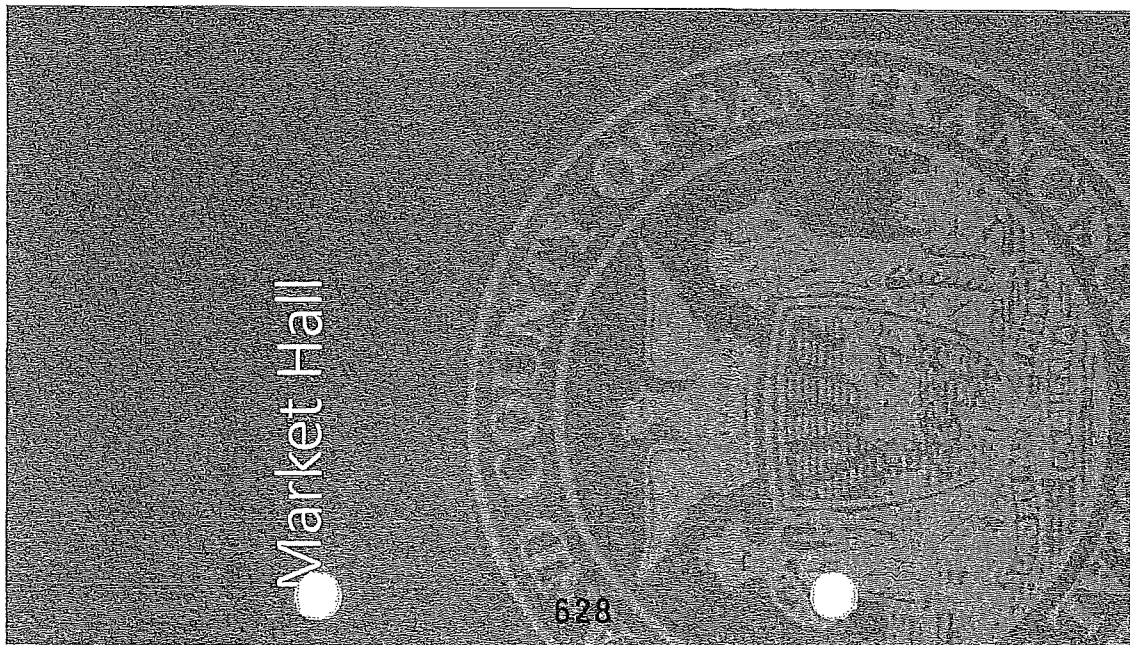
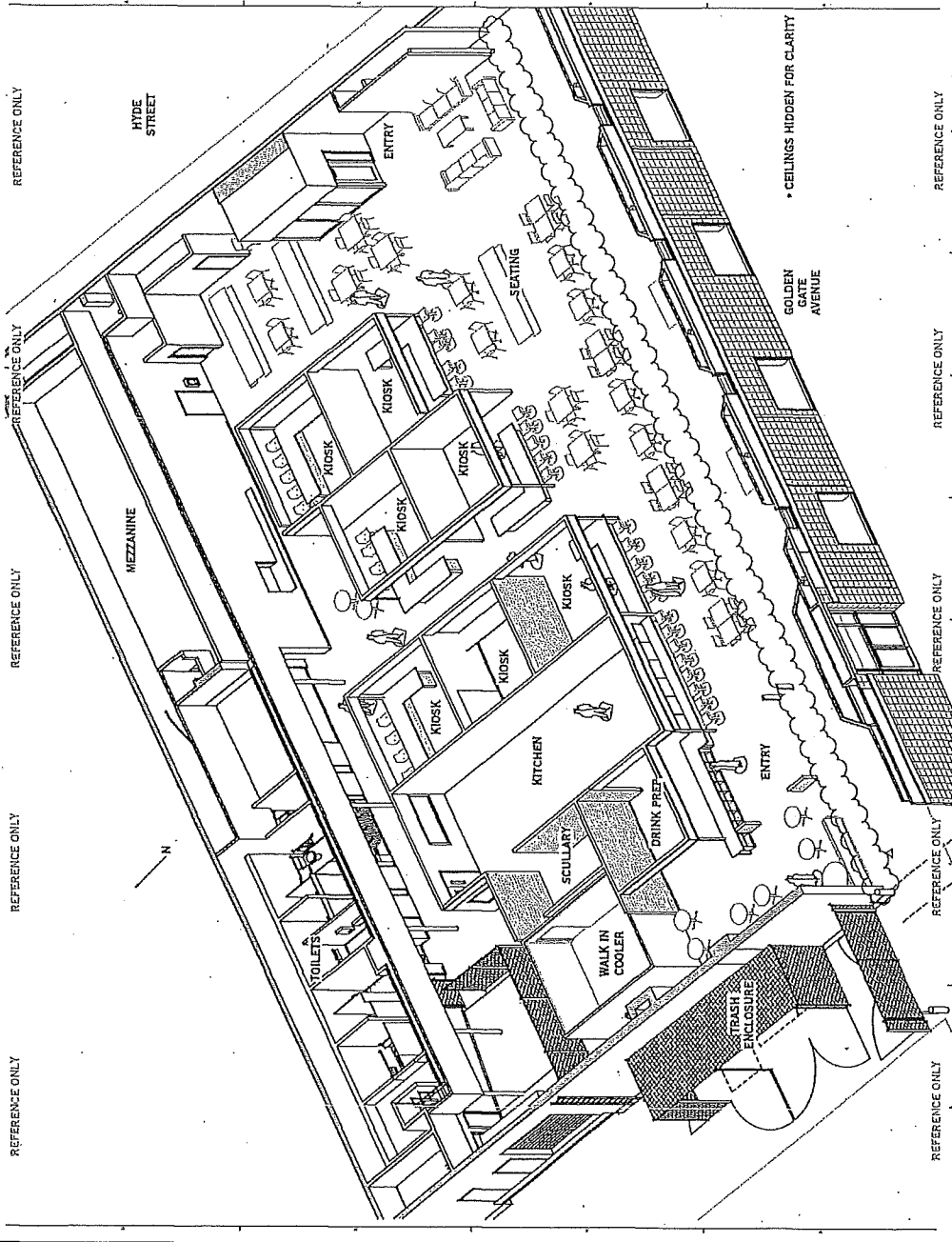

Lease Terms

629

- Proposal before BOS:
 - Lease to expire 12/31/25, replaces year to year lease
 - Monthly rent \$1,000 + 5% of net income
 - La Cocina responsible for tenant improvements, with up to \$1,465,000 reimbursable by the City
 - La Cocina responsible for all costs associated with operating the premises



Next Steps

630

- BOS Approval:
 - Lease (File 190166)
 - Accept & Expend (File 190167)
- Project Timeline:
 - Start TI Construction ~May 2019
 - Complete TIs~ November 2019
 - Anticipated Opening January 2020

101 Hyde Interim Use

Budget & Finance Committee

February 27, 2019



Mayor's Office of Housing and Community Development – Amy Chan

Real Estate Department - Josh Keene

Office of Economic and Workforce Development – Lisa Pagan

FORM SFEC-126:
NOTIFICATION OF CONTRACT APPROVAL
 (S.F. Campaign and Governmental Conduct Code § 1.126)

City Elective Officer Information <i>(Please print clearly.)</i>	
Name of City elective officer(s): Members, Board of Supervisors	City elective office(s) held: Members, Board of Supervisors

Contractor Information <i>(Please print clearly.)</i>	
Name of contractor: La Cocina, Inc.	
<i>(1) members of the contractor's board of directors; (2) the contractor's chief executive officer, chief financial officer and chief operating officer; (3) any person who has an ownership of 20 percent or more in the contractor; (4) any subcontractor listed in the bid or contract; and (5) any political committee sponsored or controlled by the contractor</i>	
(1) Laura Ambroseno, Alison Arth, Suzanne Cutts, Lindsay Hower, Surina Khan, Marty Sanchez, Jagadha Sivan, Katie Truitt Sharafi, Sarah Wigglesworth, Dara Zandanel, Daniel Lee, Dilsa Lugo, Amir Massih, Seema Patel	
(2) Caleb Zigas is the Executive Director, our organization equivalent to CEO. The chairs of our Finance Committee are Lindsay Hower and Seema Patel, both members of our Board, with support from La Cocina operations director, Aniela Valtierra.	
(3) N/A	
(4) None.	
(5) None.	
Contractor address: 2948 Folsom Street; San Francisco, CA 94110	
Date that contract was approved:	Amount of contract: \$1,465,000
Describe the nature of the contract that was approved: Commercial lease through 12/31/2025	
Comments: \$1.465M is for tenant improvements	

This contract was approved by (check applicable):

the City elective officer(s) identified on this form

a board on which the City elective officer(s) serves: San Francisco Board of Supervisors
Print Name of Board

the board of a state agency (Health Authority, Housing Authority Commission, Industrial Development Authority Board, Parking Authority, Redevelopment Agency Commission, Relocation Appeals Board, Treasure Island Development Authority) on which an appointee of the City elective officer(s) identified on this form sits

Print Name of Board

Filer Information <i>(Please print clearly.)</i>	
Name of filer: Angela Calvillo, Clerk of the Board	Contact telephone number: (415) 554-5184
Address: City Hall, Room 244, 1 Dr. Carlton B. Goodlett Place, San Francisco, CA 94102	E-mail: Board.of.Supervisors@sfgov.org

Signature of City Elective Officer (if submitted by City elective officer)

Date Signed

Signature of Board Secretary or Clerk (if submitted by Board Secretary or Clerk)

Date Signed